

**LEXINGTON-FAYETTE URBAN COUNTY GOVERNMENT
CONTRACT CHANGE ORDER
Page 1 of 2**

Date:	April 10, 2017
Project:	Government Center Parking Garage Repair
Location:	200 East Main
Contract No.	034-2017
Original Contract Amt.	\$144,230.00
Cumulative Amount of Previous Change Orders	\$0.00
Percent Change - Previous Change Orders	0.00%
Total Contract Amount Prior to this Change Order	\$144,230.00
Change Order No.	1

R-269-2017
Original R-089-2017
Contract # 034-2017

To (Contractor):
Browning Chapman, LLC
9900 Westpoint Drive, Suite 128
Indianapolis, IN 46256

You are hereby requested to comply with the following changes from the contract plans and specification;

Current Change Order

Item No.	Description of changes-quantities, unit prices, change in completion date, etc.	Decrease in contract price	Increase in contract price
1	New lintel at Main Street garage door opening	\$0.00	\$14,965.00
	Total decrease	\$0.00	
	Total increase		\$14,965.00
	Net Amount of this Change Order	\$14,965.00	
	New Contract Amount Including this Change Order	\$159,195.00	
	Percent Change - This Change Order		10.38%
	Percent Change - All Change Orders		10.38%

The time provided for the completion in the contract and all provisions of the contract will apply hereto.

Recommended by	<i>[Signature]</i>	(Proj. Mgr.)	Date	4/10/17
Accepted by	<i>[Signature]</i>	(Contractor)	Date	4/10/17
Approved by	<i>[Signature]</i>	(Director)	Date	4-10-17
Approved by	<i>[Signature]</i>	(Commissioner)	Date	4-10-17
Approved by	<i>[Signature]</i>	(Mayor or CAO)	Date	5-11-17

JUSTIFICATION FOR CHANGE

PROJECT: Government Center Parking Garage Repair

CONTRACT NO. 034-2017

CHANGE ORDER: 1

1. Necessity for change: Install new steel lintel above the Main Street garage door at the Government Center garage, which includes brick removal and reinstall, replacement lintel, and new brick ties, membrane, and flashing for \$14,965.00.

2. Is proposed change an alternate bid? ___ Yes X No
3. Will proposed change alter the physical size of the project? ___ Yes X No
If "Yes", explain.
4. Effect of this change on other prime contractors: N/A
5. Has consent of surety been obtained? ___ Yes X Not Necessary
6. Will this change affect expiration or extent of insurance coverage? ___ Yes X No
If "Yes", will the policies be extended? ___ Yes ___ No
7. Effect on operation and maintenance costs: N/A
8. Effect on contract completion date: N/A



Mayor

5-11-17

Date



9900 Westpoint Drive
Suite 128
Indianapolis, IN 46256
Phone: (317) 608-2775

April 6, 2017

THP Limited, Inc.
100 E. 8th Street
Cincinnati, OH 45202

Attn: Anthony Mette

Project: Lexington Government Center garage
200 East Main Street Lexington, Kentucky

Description of Work: Install new brick lintel at garage door opening on Main street.

- o Remove brick and re-install existing brick
- o Replace lintel with new galv dipped lineal (Three sections)
- o Install brick ties, membrane and flashing per THP detail.

Dear Anthony,

We propose to provide all necessary labor, materials, and equipment to complete the following:

Scope of Work:

1. Shore sections as needed and block door with proper signage.
2. Remove sections of brick, cut lintel and remove section.
3. Install new lintel and anchor. Place stainless steel flashing over steel lintel seems. Apply Carlisle waterproofing over anchors and Lintel.
4. Place posi-ties and set brick. Tuckpoint brick and misc areas on each side of entry.

Special Note:

- Steel lintel will be replaced in THree sections.
 - Price includes lift for access, signage and shoring.
 - Price includes re-using the existing brick. Sample mortar will be installed for approval.
- In new brick is needed, BC will match as close as possible.

Price: \$14,965.00

Thank you for the opportunity to provide a quotation for this work. Please feel free to contact me at any time if you should have questions or wish for us to proceed.

Yours very truly,

BROWNING CHAPMAN, LLC

Gordon Chapman
Vice President/Chief Operating Officer

Date:	7-Apr-17
Project Name	Lexington Government Center Garage
Location	
City/State/Zip	200 East Main Street Lexington KY
Phone:	
Fax:	
Site Contact:	Mark Arnold
Pager:	
Cell Phone:	(859) 338-9347
Owner/Contractor	
Address:	
City/State/Zip	
Phone:	
Fax:	
Office Contact:	
Pager:	
Cell Phone:	
Special Conditions	

M/D	Area	Labor Activities	
		SEVEN LINTELSECTIONS AT MAIN ST	
3		Remove 21 feet soldier row	
3		Tear out 21 feet of lintel (3 sections)	
3		Install new Lintel (3 sections)	
3		Install flashing	
1		Install waterproofing	
		Re-install soldier row	
		Install Posities	
2		Tuckpoint brick	
3		Tuckpoint 50 lineal feet on each side of door	
18		Total Man Days	
9		Mechanic @330 /8 Hour Day	\$2,970
9		Apprentice @ \$253/8 Hour Day	\$2,277
		Helper @\$214 /8 Hour Day	\$0
		Premium Time	
		Per Diem	\$1,800
		Total Labor Cost	\$7,047
		Gross Margin	\$1,057.05
		Total Labor	\$8,104

Items	Unit	Qty	U/P	Extension	Totals
Materials					
				\$0.00	
Steel Lintels		7	\$300.00	\$2,300.00	
Carlise Membrane		1	\$110.00	\$110.00	
Mastic 704 (tubes)		6	\$12.00	\$72.00	
Primer 702 (pail)		1	\$150.00	\$150.00	
Flashng (4-1/2 length)		7	\$50.00	\$350.00	
Anchors (HAS-E ROD) 1/2 x8"		1	\$ 225.00	\$225.00	
HIT-HY 200 R		7	\$ 40.00	\$280.00	
315 C Wall Ties		1	\$ 190.00	\$190.00	
Spec Mix Mortar		4	\$16.00	\$64.00	
Daily Sundrees		9	\$45.00	\$405.00	
				\$0.00	
				\$0.00	\$4,146.00
Equipment Allocation					
				\$0.00	
Scissor lift		1	\$300.00	\$300.00	
Rental pole shoes		2	\$100.00	\$200.00	
				\$0.00	
				\$0.00	\$500.00
Small Tools Purchased				\$0.00	\$0.00
Equipment Rental				\$0.00	\$0.00
Equipment Purchased				\$0.00	\$0.00
Safety Equipment				\$0.00	\$0.00
Dump Fees				\$0.00	\$0.00
Bonds				\$0.00	\$0.00
TRAVEL OFFICE..		2	\$150.00	\$300.00	\$300.00
Site Fuel Expense		2	\$40.00	\$80.00	\$80.00
Office Travel Fuel		2	\$140.00	\$280.00	\$280.00
Freight		1	\$200.00	\$200.00	\$200.00
Mobilization				\$0.00	\$0.00
Company Del (Out & Back)		2	\$86.00	\$172.00	\$172.00
Misc. Expense				\$0.00	\$0.00
				\$0.00	\$0.00
Sales Tax		8%	\$4,146.00	\$331.68	\$331.68
Subtotal					\$5,678.00
Gross Margin					\$851.70
Total					\$6,529.70
Labor Cost					\$7,047.00
Gross Margin					\$1,057.05
Total Labor					\$8,104.05
Total Sell Price					\$14,965.43
Unit Price					\$2,137.92

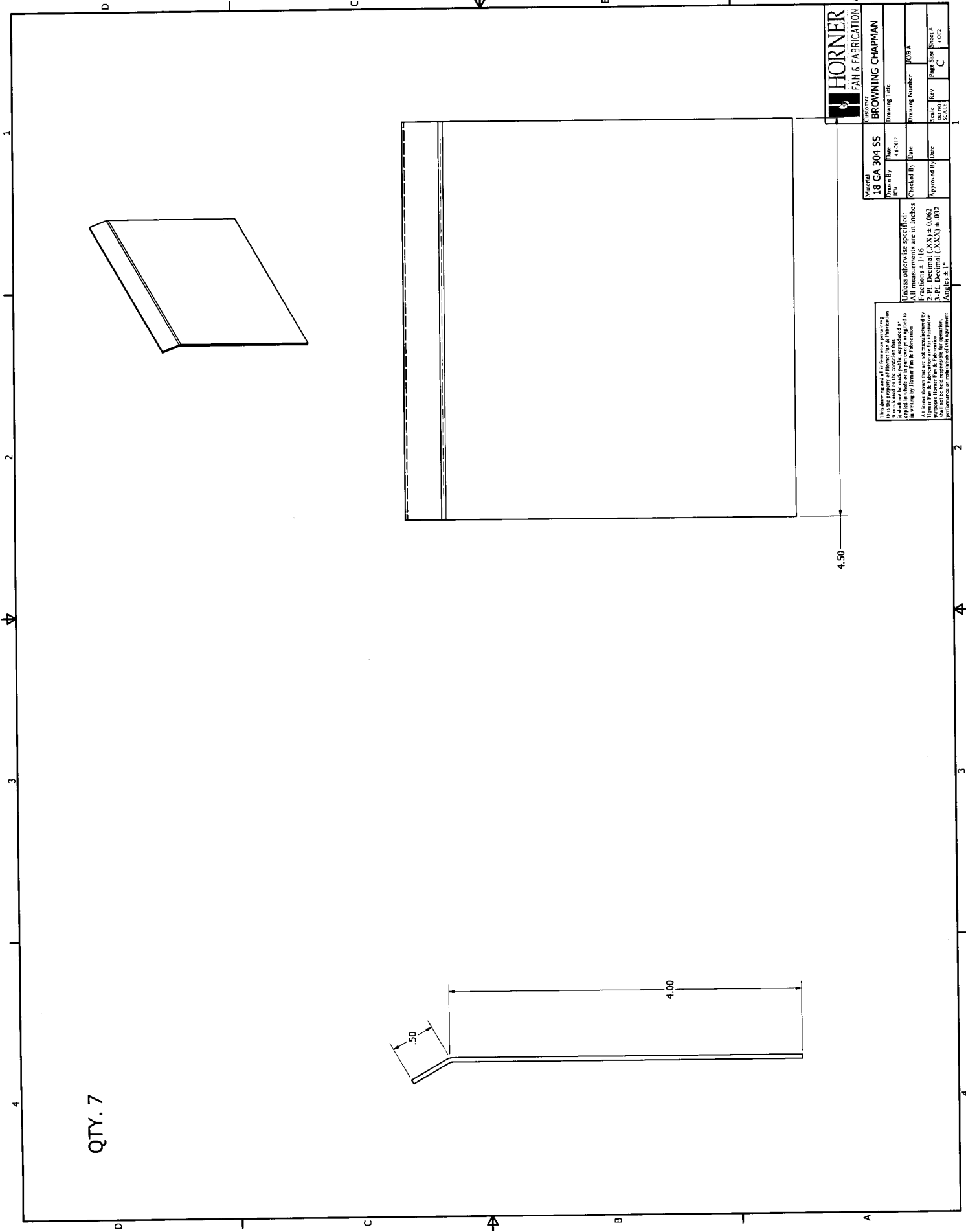

QTY. 7

HORNER
FAN & FABRICATION

Customer: **BROWNING CHAPMAN**

Material: **18 GA 304 SS**

Drawn By: **AME**

Checked By: **[Blank]**

Approved By: **[Blank]**

Scale: **Rev**

SCALE: **C**

Drawing Number: **[Blank]**

Job # **[Blank]**

Page Size: **Sheet #**

Sheet # **1 OF 2**

Unless otherwise specified:
 All measurements are in inches
 1-PL Decimal (.XX) ± 0.002
 2-PL Decimal (.XXX) ± 0.002
 3-PL Decimal (.XXX) ± 0.002
 Angles ± 1°

All drawings are the property of Horner Fan & Fabrication. No part of this drawing may be reproduced or copied in whole or in part except as agreed in writing by Horner Fan & Fabrication. This drawing is for the use of the customer only. Horner Fan & Fabrication is not responsible for the performance or malfunction of any equipment.

4.50

4.00

.50

QTY. 7
HOT DIPPED GALV

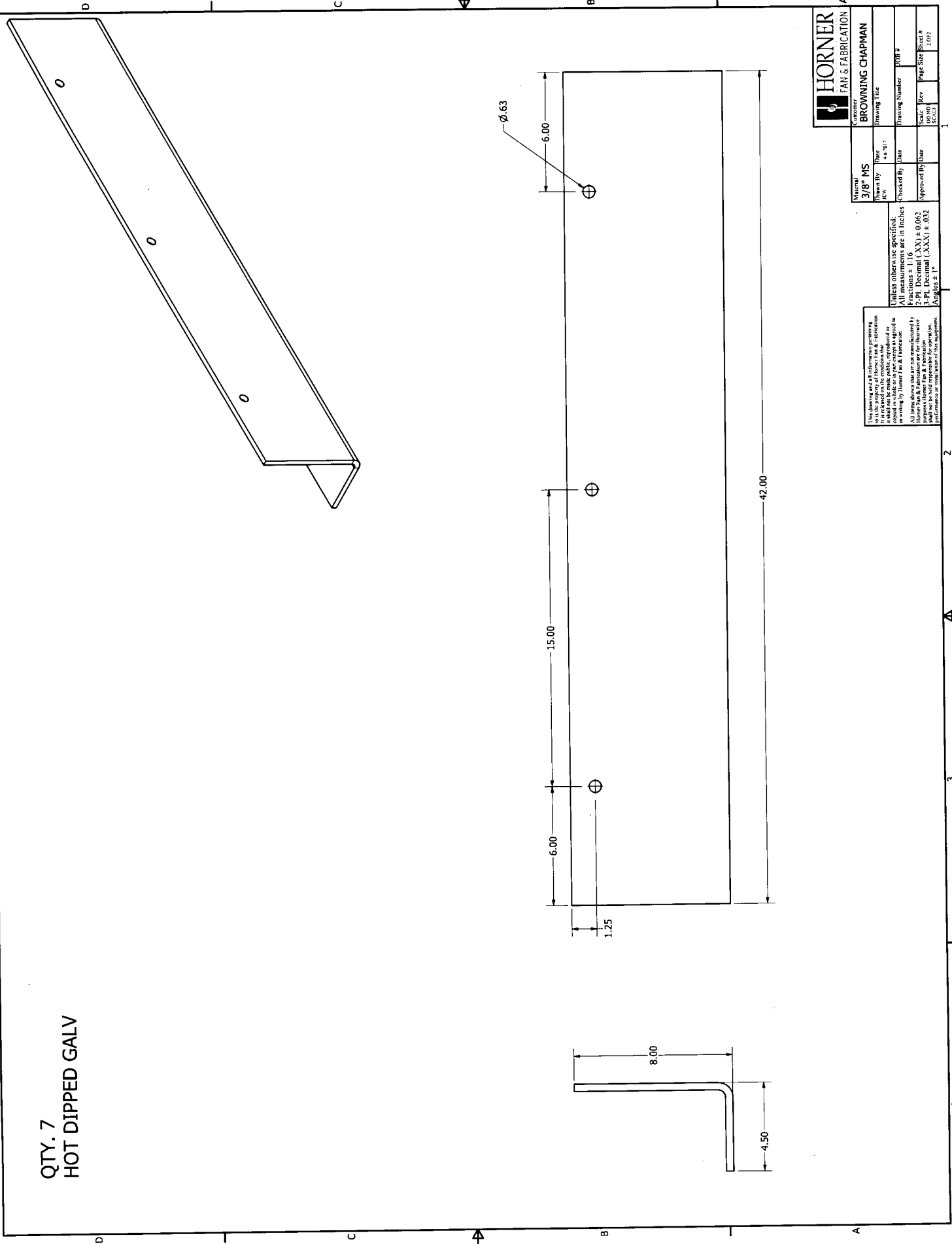

HORNER
FAN & FABRICATION

Customer: **BROWNING CHAPMAN**

Material	3/8" MS	Part	44-501
Drawn By	JCV	Checked By	DATE
Scale	1:1	Approved By	DATE
Sheet	100	Rev	2.012
Scale	1:1	Page Size	J.012

Unless otherwise specified:
 2-PL Decimal (XX) ± 0.062
 3-PL Decimal (XXX) ± .032
 Angles ± 1°

This drawing and all information pertaining to it is the property of Horner Fan & Fabrication and shall not be made public, reproduced or used in any way without the express permission of Horner Fan & Fabrication.

All items shown that are not manufactured by Horner Fan & Fabrication are for illustrative purposes only. Horner Fan & Fabrication shall not be held responsible for operation, performance or maintenance of these equipment.

Dovetail Anchors, Slots & Ties

315 - Flexible Dovetail Brick Tie

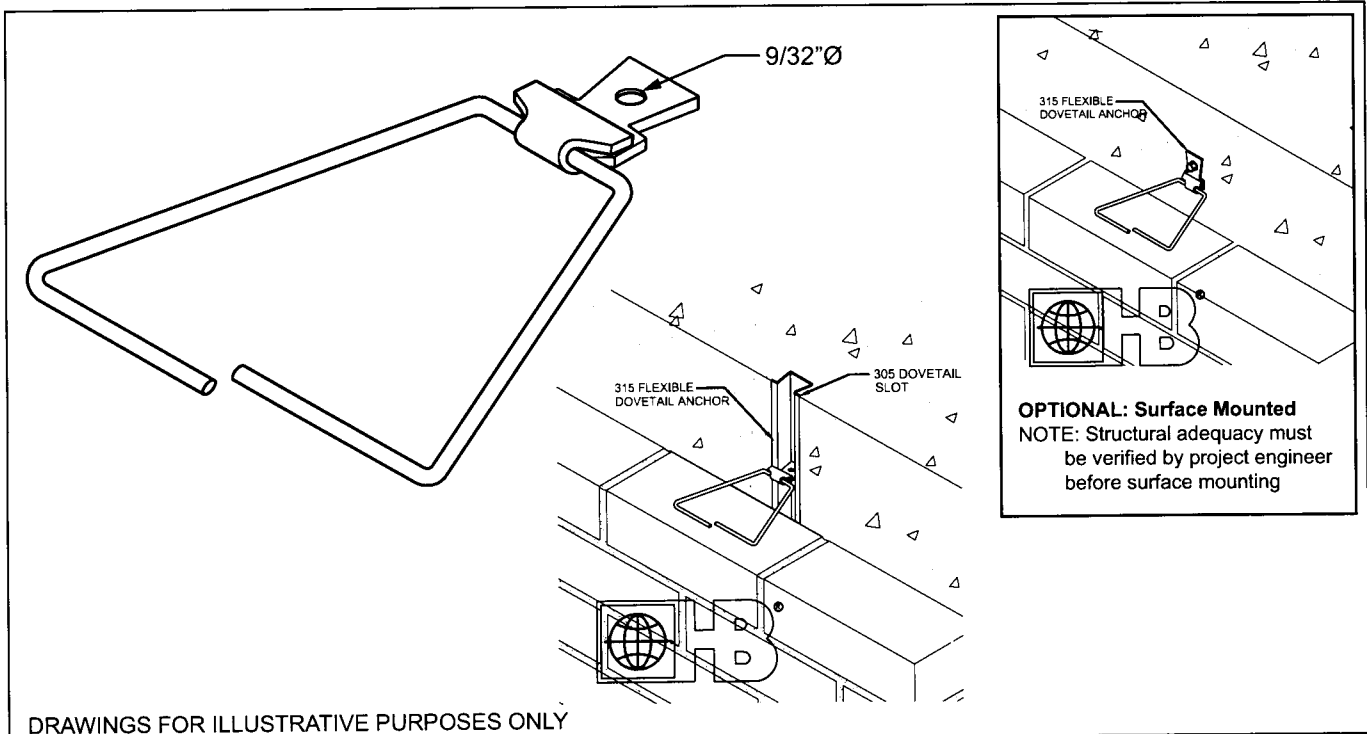

DRAWINGS FOR ILLUSTRATIVE PURPOSES ONLY

315 Flexible Dovetail Brick Tie permits horizontal and vertical movement of the masonry wall while, restraining tension and compression.

MATERIAL CONFORMANCE

Wire (Carbon Steel): Prefabricated from cold-drawn steel wire conforming to **ASTM A1064/A1064M**
Tensile Strength - 80,000 p.s.i. | Yield Point - 70,000 p.s.i. minimum
Zinc Coating:
Hot-Dip Galvanized: **ASTM A153/A153M Class B** (1.5 oz/ft²) (sheet metal ties and anchors galvanized after fabrication)

Wire (Stainless Steel):
ASTM A580/A580M - AISI Type 304 (Type 316 available on special order)

Sheet Metal (Carbon Steel):
ASTM A1008/A1008M
Zinc Coating:
Hot-Dip Galvanized (refer to wire conformance above)

Sheet Metal (Stainless Steel):
ASTM A666, ASTM A480/480M, and ASTM A240/A240M AISI Type 304 or 316

Vee Byna-Tie® portion manufactured from a minimum of 95% post-consumer recycled material.

Finish:

- Hot-Dip Galvanized
 Stainless Steel - Type 304
 Stainless Steel - Type 316 (available on special order)

Note: Hohmann & Barnard recommends Stainless Steel for maximum protection against corrosion.

Dovetail Head Thickness:

- 14 Gauge 12 Gauge

Vee Byna-Tie® Length:

- 3" 3 1/2" 4" 4 1/2"
 5" Other _____

Vee Byna-Tie® Diameter:

- 3/16"Ø (standard) 1/4"Ø (heavy-duty)

315 - Flexible Dovetail Brick Tie is manufactured for use with Hohmann & Barnard 305 Dovetail Slot.

H&B is not responsible for incompatibility if ties or slots are interchanged with those of other manufacturers.

IMPORTANT: Since each construction project is unique, the appropriate selection and use of any product contained herein must be determined by competent architects, engineers and other appropriate professionals who are familiar with the specific requirements of the project in question.



WATERPROOFING

MIRADRI[®] 860/861

Description

CCW MiraDRI[®] 860/861 are self-adhering sheet membranes consisting of 56 mils (1.4 mm) of rubberized asphalt laminated to 4 mils (0.1 mm) of polyethylene to form a minimum 60-mil (1.5 mm) membrane. MiraDRI 860 membrane is suitable for installations where the ambient temperature is 40°F (4.4°C) or above. MiraDRI 861 should be used for applications between 25°F (-3.9°C) and 65°F (18°C). The combination of these two excellent waterproofing materials provides a high-performance, extremely durable waterproofing barrier.

MiraDRI 860/861 membranes are used for vertical and horizontal waterproofing on structural foundation walls and decks. Below-grade foundation walls, tunnels, split slabs, plaza decks and parking decks are all areas where MiraDRI 860/861 may be applied. MiraDRI 860/861 also may be used in interior areas such as mechanical rooms, laboratories, kitchens and bathrooms. MiraDRI 860/861 should be covered with either CCW 200V/300HV Protection Course, CCW Protection Board, or CCW MiraDRAIN[®] drainage composites.

Installation

Preparation: Do not apply MiraDRI 860/861 to frozen or wet substrates. The membrane should not be left exposed to direct sunlight for longer than 14 days. MiraDRI 860/861 can be applied to concrete, metal, wood, insulated wall systems or masonry surfaces. All substrates must be clean, dry and free of surface irregularities.

Concrete Substrates: Structural concrete must be cured a minimum of 7 days and lightweight structural concrete must cure a minimum of 14 days before the application of MiraDRI 860/861. Repair surfaces that are not structurally sound or have voids, protrusions, rough spalled areas, loose aggregate or exposed coarse aggregate. Any voids exceeding 1/4" in width should be filled with latex Portland cement, concrete or epoxy concrete and troweled smooth to match the existing surface. Protrusions and other rough areas should be broken off and patched as above. CCW LM 800XL, CCW 201, or CCW 703V may be used to fill small voids, honeycombs or bug holes.

Masonry Substrate: Apply MiraDRI 860/861 waterproofing over concrete block with smooth trowel-cut mortar joints or rough surfaces prepared with a parge coat. Allow the parge coat to dry before priming and installing the MiraDRI 860/861 waterproofing membrane.

Chemical Additives: Concrete shall be cured by water curing method.

Any curing compounds must be of the pure sodium silicate type or clear resin-based materials without waxes, oils or pigments and be approved by the Carlisle representative. Form release agents must not transfer to the concrete. Remove forms as soon as possible from below horizontal slabs to prevent entrapment of excess moisture. Excess moisture may lead to blistering of the membrane. Curing compounds or form release agents that adversely affect the adherence of the MiraDRI 860/861 waterproofing membrane must be removed from the substrate prior to application.

Priming: All concrete, metal, masonry, wood and sheathing substrates require CCW Contact Adhesive. Insulated concrete forms require a water-based CCW Contact Adhesive. Carlisle Coatings & Waterproofing recommends an adhesion test of the MiraDRI 860/861 on any bare substrate to verify proper adhesion. Apply the appropriate CCW Contact Adhesive at the specified coverage rate. Apply Contact Adhesive with a lambswool roller, brush or spray apparatus. Allow Contact Adhesive to dry for a minimum of 30 minutes. The CCW Contact Adhesive will dry to a tacky finish. Areas primed with a CCW Contact Adhesive but not covered with MiraDRI 860/861 within the same day must be re-primed.

When installing CCW sheet membranes and sheet flashings over gyp-sheathing with glass-mat facers, coverage rates for contact adhesives and primers will depend on the porosity and texture of the sheathing and will vary substantially by gypsum-sheathing brand and manufacturer. To achieve consistent contact adhesive and/or primer coverage with adequate tack, it may be necessary to decrease the coverage rate (i.e. increase the amount applied) of the contact adhesive and/or primer and/or the application of multiple coats. CCW Contact adhesives and primers shall be allowed to dry completely (lower temperatures will extend drying time) before additional coats are applied or membranes installed. Caution should be taken as contact adhesives and/or primers applied to gyp-sheathings with glass-mat facers will take longer to dry than other substrates. Multiple adhesion tests should be performed randomly to verify proper application of primer and ensure a successful application.

Detailing: All vertical-to-horizontal transitions must have a 3/4" (19.05 mm) fillet of CCW LM-800XL, CCW-201 Sealant or CCW-703V Liqueal. Allow CCW-LM-800XL to cure 1 hour, CCW-703V to cure 4 hours, CCW-201 to cure 16 hours before covering with the MiraDRI 860/861 membrane. All inside and outside corners, as well as the vertical-to-horizontal transitions, should have a minimum 9" detail strip of MiraDRI 860/861 installed prior to the field membrane of MiraDRI 860/861. The

WATERPROOFING

MIRADRI 860/861

MiraDRI 860/861 Membrane Strip should be centered on corners, joints, cracks and transitions. After field membrane is installed, a sealant bead of CCW LM-800XL, CCW-704, CCW-201, or CCW-703V should all be placed over all laps at the footing/wall transition extending a minimum of 9" up the wall and 9" out over the footing. Refer to the standard detail drawings for specific detail instructions.

Vertical Installation

Start at the low point and work towards the high point. Remove 6"–8" (150–200 mm) of the release paper, and then begin applying the membrane. Press and smooth the membrane against the substrate while pulling the release paper free. Roll entire membrane and laps with a hard rubber hand roller. Install membrane with side laps overlapped a minimum of 2½" (63 mm) and end laps a minimum of 5" (127 mm). CCW recommends that the membrane be rolled in place immediately after its placement to ensure full adhesion to the primed substrate. Apply a bead of CCW 704, CCW LM 800XL, or CCW 703V Liqueiseal at terminations, cut edges, T-joints, drains, penetrations. CCW 704 Mastic should not be installed on the underside of CCW MiraDRI 860/861. For walls over 8' (240 cm), the membrane should be placed in lifts. Protect the MiraDRI 860/861 membrane with the appropriate CCW MiraDRAIN drainage composite, CCW 200V/300HV Protection Course, or CCW Protection Board V.

Horizontal Installation

Start at the low point (establish a starting point with a chalk line if necessary) and work towards the high point in shingle fashion. Remove 2–3' (60–90 cm) of the release paper and apply the membrane to the substrate. Continue pulling the release paper free while pressing and smoothing the membrane against the substrate. Apply in a straight line avoiding wrinkles and over-correcting. Roll the membrane with a minimum 75-lb. (34 kg) linoleum roller. Install membrane with side laps overlapped a minimum of 2½" (63 mm) and end laps a minimum of 5" (127 mm). Apply a bead of CCW-704 Mastic at all terminations of the membrane and T-joints. Apply a ¼" (19.05 mm) fillet of CCW LM 800XL, CCW 201, or CCW 703V Liqueiseal in all inside corners of planter boxes, shower stalls and shower pans. Patch inadequately lapped seams and damaged areas with MiraDRI 860/861 membrane covering the damaged area by a minimum of 6" (150 mm). "Fish-mouths" and severe wrinkles should be slit, flaps overlapped and repaired as above. Protect the MiraDRI 860/861 membrane with the appropriate CCW MiraDRAIN drainage composite or CCW 300HV Protection Course.

Detail Requirements: For standard installation details follow the

MiraDRI 860/861 details drawings. For non-standard installation instructions contact your local CCW representative.

Limitations

Do not apply where membrane will be subject to continuous exposure to sunlight. The membrane should not be left exposed to direct sunlight for longer than 14 days.

Do not apply primer or membrane to a damp, frosty, frozen, or contaminated surface.

Not recommended as a pond or tank liner except for between-slab applications.

Do not apply over sealants containing coal tar or polysulfides. In the event of existing bitumen-modified materials, consult your CCW representative.

Warnings and Hazards

CCW Contact Adhesives, Mastics and Sealants may contain flammable and combustible solvents. Avoid exposure to open flame or spark. Avoid breathing vapors. Use only in areas with adequate ventilation. Refer to MSDS for important warnings and product information.

Packaging

Product	Size/Weight
CCW MiraDRI 860/861	36" wide x 67' roll (200 ft ²) 25 rolls/pallet (5000 ft ²) Weight = 80 lb/roll (approx.)
CCW-702LV VOC-Compliant Solvent Base Contact Adhesive	5-gallon pails (45 pails/pallet)
CCW-702WB Water Base Contact Adhesive	5-gallon pails (45 pails/pallet)
CCW-AWP Water Base Contact Adhesive	1-gallon pails (100 pails/pallet) 5-gallon pails (45 pails/pallet)
CCW-702 Solvent Base Contact Adhesive	5-gallon pails (45 pails/pallet)
CCW-715 Damp Concrete Contact Adhesive	5-gallon pails (45 pails/pallet)
CCW-704 Mastic and CCW LM-800XL	30-oz Qt. Tube (12 tubes/carton) 5-gallon pails (45 pails/pallet)
CCW-703V Liqueiseal	3.5-gal Part A/0.5-gal Part B (45 lbs unit)
CCW-LM-800XL	5-gallon (19-liter) pails 29-oz (822-kg) tubes, 12 per box
CCW-201	1.5-gallon kit (in 2-gallon pail)

Standards

- GCW MiraDRI 860, 861 meets the applicable requirements of:
- GSA: PBS PCD 07121
- USN: NAVFAC TS-07111
- VA: H-08-1
- Federal Construction Guide Specs; FCGS-07111
- Corps of Engineers; CECS-07111-3-82
- UL 790, Class A
- LA Research Report Number 25094L

Typical Properties

Property	Method	Results
Color	—	Dark Gray
Thickness	ASTM D3767	60 mils
Tensile (Membrane)	ASTM D412	325 psi
Tensile (Film)	ASTM D382	5000 psi
Elongation	ASTM D412	350%
Permeance	ASTM E96	0.05 perms
Low Temp. Flexibility ¹	ASTM D1970	Unaffected
Crack Cycling ²	ASTM C636	Unaffected
Peel Strength	ASTM D903	19.0 lb/in
Lap Adhesion	ASTM D1876	19.0 lb/in
Puncture Resistance	ASTM E154	60 lb/min
Soil Burial at 16 wks	GSA-PBS 07121	No effect
Water Absorption	ASTM D570	0.1% by wt
Hydrostatic Head	ASTM D5385	230 ft

¹ 100% elongation at -25°F; 100% elongation at -45°F; 45°F
² 100 cycles at 45°F; 45°F

SCIENCE. SERVICE. SOLUTIONS.



WATERPROOFING

MIRADRI 860/861

Limited Warranty

Carlisle Coatings & Waterproofing Incorporated (Carlisle) warrants this product to be free of defects in workmanship and materials only at the time of shipment from our factory. If any Carlisle materials prove to contain manufacturing defects that substantially affect their performance, Carlisle will, at its option, replace the materials or refund its purchase price. This limited warranty is the only warranty extended by Carlisle with respect to its materials. There are no other warranties, including the implied warranties of merchantability and fitness for a particular purpose. Carlisle specifically disclaims liability for any incidental, consequential, or other damages, including but not limited to, loss of profits or damages to a structure or its contents, arising under any theory of law whatsoever. The dollar value of Carlisle's liability and buyer's remedy under this limited warranty shall not exceed the purchase price of the Carlisle material in question.



TO: Mayor Jim Gray
Urban County Council

FROM: 
Geoffrey Reed, Commissioner, General Services

CC: Jamshid Baradaran, Director, Facilities and Fleet Management
Jessica Walker, Administrative Officer, General Services
Mark Arnold, Facilities Manager, Facilities & Fleet Management
Sandra Lopez, Administrative Officer, Facilities & Fleet Management

DATE: April 10, 2017

SUBJECT: Request a Resolution authorizing the Mayor, on behalf of the Urban County Government, to execute Change Order No. One (1) to the Contract with Browning Chapman, LLC for the Government Center Parking Garage Repair Project, increasing the contract price in the amount of \$14,965.00 from \$144,230.00 to \$159,195.00.

Request

Authorization to: Execute Change Order #1 with Browning Chapman, LLC in the amount of \$14,965.00 for the Government Center Parking Garage Repair Project Contract # 034-2017. The new contract amount including this change order is \$159,195.00.

Why are you requesting? Necessity for change: Install new steel lintel above the Main Street garage door at the Government Center garage, which includes brick removal and reinstall, replacement lintel, and new brick ties, membrane, and flashing for \$14,965.00.

Department needs this action completed because: To adjust the contract as required for construction.

What is the cost in this budget year and future budget years?

The cost for this FY is: \$14,965.00 The cost for future FY is: N/A

Are the funds budgeted?

The funds are budgeted or a budget amendment is in process: Budgeted



Account number:

FUND	DEPT ID	SECTION	ACCOUNT	BUDGET REF	AMOUNT
1105	707501	7041	91012	2016	\$14,965.00

File Number:

Browning Chapman, LLC Contract #034-2017

Commissioner/ Director:

Geoffrey Reed, Commissioner, General Services
Jamshid Baradaran, Director, Facilities and Fleet Management

