

RESOLUTION NO. 335 -2013

A RESOLUTION ACCEPTING THE BID OF XYLEM DEWATERING SOLUTIONS, INC. D/B/A GODWIN PUMPS OF AMERICA, ESTABLISHING A PRICE CONTRACT FOR EMERGENCY PUMPS & ACCESSORIES, FOR THE DIVISION OF WATER QUALITY.

BE IT RESOLVED BY THE COUNCIL OF THE LEXINGTON-FAYETTE URBAN COUNTY GOVERNMENT:

Section 1 - That the bid of Xylem Dewatering Solutions, Inc. d/b/a Godwin Pumps of America, establishing a price contract for Emergency Pumps & Accessories, for the Division of Water Quality, be and hereby is accepted and approved as to the specifications and amounts set forth in the terms of the bid, which is attached hereto and incorporated herein by reference.

Section 2 - That this Resolution shall become effective on the date of its passage.

PASSED URBAN COUNTY COUNCIL: July 2, 2013

MAYOR

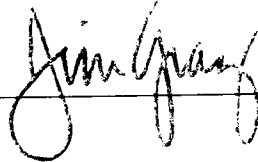

ATTEST:

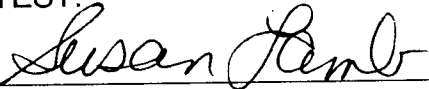

CLERK OF URBAN COUNTY COUNCIL

623-13:DJB:X:\Cases\WATER-AIR\13-LE0001\LEG\00394044.DOC



Lexington-Fayette Urban County Government

200 E. Main St
Lexington, KY 40507

Master

File Number: 0623-13

File ID: 0623-13	Type: Resolution	Status: Approved
Version: 1	Contract #:	In Control: Urban County Council
Division: Central Purchasing	Cost:	File Created: 06/03/2013
File Name: Recommendation for Bid #58-2013 Emergency Pumps & Accessories		Final Action: 07/02/2013

Title: A Resolution accepting the bid of Xylem Dewatering Solutions, Inc. d/b/a Godwin Pumps of America, establishing a price contract for Emergency Pumps and Accessories, for the Div. of Water Quality. (2 Bids, Low) [Martin]

Notes:

Code Sections:

Agenda Date: 07/02/2013

Indexes:

Agenda Number: 2.

Sponsors:

Enactment Date: 07/02/2013

Attachments: Xylem Dewatering Solutions-Goodwin Pumps.pdf, insurance certificate for Xylem.pdf, Umbrella insurance certificate for Xylem.pdf, 00394044.DOC

Enactment Number: R-335-2013

Deed #:

Hearing Date:

Drafter: Betty Landrum

Effective Date:

Approval History

Version	Date	Approver	Action
1	06/03/2013	Todd Slatin	Approve
1	06/03/2013	Sally Hamilton	Approve
1	06/04/2013	Dave Barberie	Approve

History of Legislative File

Ver- sion:	Acting Body:	Date:	Action:	Sent To:	Due Date:	Return Date:	Result:
1	Urban County Council	06/20/2013					
1	Urban County Council	06/20/2013	Received First Reading	Urban County Council	07/02/2013		

INVITATION TO BID

Bid Invitation Number: **58-2013**

Date of Issue: **05/06/2013**

Sealed bids will be received in the office of the Division of Central Purchasing, 200 East Main Street, Lexington, Kentucky, until **2:00 PM**, prevailing local time on **05/20/2013**. Bids must be received by the above-mentioned date and time. Mailed bids should be sent to:

**Division of Central Purchasing
200 East Main Street, Room 338
Lexington, KY 40507, (859) 258-3320**

The Lexington-Fayette Urban County Government assumes no responsibility for bids that are not addressed and delivered as indicated above. Bids that are not delivered to the Division of Central Purchasing by the stated time and date will be rejected.

All bids must have the company name and address, bid invitation number, and the commodity/service on the outside of the envelope.

Bids are to include all shipping costs to the point of delivery located at: 301 Lisle Industrial Ave. Lex., KY 40511

Bid Security Required: Yes No Performance Bond Required: Yes No
Cashier Check, Certified Check, Bid Bond (Personal checks and company checks will not be acceptable).

Quantity	Commodity/Service
Price Contract	Emergency Pumps & Accessories

<p style="text-align: center;"><u>Check One:</u></p> <p><input checked="" type="checkbox"/> Bid Specifications Met <input type="checkbox"/> Exceptions to Bid Specifications. <i>Exceptions shall be itemized and attached to bid proposal submitted.</i></p>	<p style="text-align: center;"><u>Proposed Delivery:</u></p> <p style="text-align: center;"><u>45</u> days after acceptance of bid.</p>
<p style="text-align: center;"><u>Procurement Card Usage</u></p> <p><input checked="" type="checkbox"/> Yes The Lexington-Fayette Urban County Government will be using Procurement Cards to purchase goods and services and also to make payments. Will you accept Procurement Cards? <input type="checkbox"/> No</p>	

Submitted by: Xylem Dewatering Solutions / Godwin Pumps
Firm
5329 Sissonville Drive
Address
Charleston, WV 25312
City, State & Zip

Bid must be signed:
(original signature)

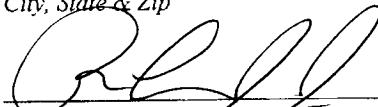
 Sales Representative
Signature of Authorized Company Representative - Title
Roger Lee Jones, Jr.
Representative's Name (Typed or printed)
304-984-0200 304-984-0665
Area Code - Phone - Extension Fax #
roger.jones@xyleminc.com
E-Mail Address

The Affidavit in this bid must be completed before your firm can be considered for award of this contract.

AFFIDAVIT

Comes the Affiant, Ricky R. Reynolds, and after being first duly sworn under penalty of perjury as follows:

1. His/her name is Ricky R. Reynolds and he/she is the individual submitting the bid or is the authorized representative of Xylem Dewatering Solutions / Godwin Pumps, the entity submitting the bid (hereinafter referred to as "Bidder").

2. Bidder will pay all taxes and fees, which are owed to the Lexington-Fayette Urban County Government at the time the bid is submitted, prior to award of the contract and will maintain a "current" status in regard to those taxes and fees during the life of the contract.

3. Bidder will obtain a Lexington-Fayette Urban County Government business license, if applicable, prior to award of the contract.

4. Bidder has authorized the Division of Central Purchasing to verify the above-mentioned information with the Division of Revenue and to disclose to the Urban County Council that taxes and/or fees are delinquent or that a business license has not been obtained.

5. Bidder has not knowingly violated any provision of the campaign finance laws of the Commonwealth of Kentucky within the past five (5) years and the award of a contract to the Bidder will not violate any provision of the campaign finance laws of the Commonwealth.

6. Bidder has not knowingly violated any provision of Chapter 25 of the Lexington-Fayette Urban County Government Code of Ordinances, known as "Ethics Act."

7. Bidder acknowledges that "knowingly" for purposes of this Affidavit means, with respect to conduct or to circumstances described by a statute or ordinance defining an offense, that a person is aware or should have been aware that his conduct is of that nature or that the circumstance exists.

Further, Affiant sayeth naught.

Ricky R. Reynolds

STATE OF West Virginia

COUNTY OF Kanawha

The foregoing instrument was subscribed, sworn to and acknowledged before me

by Ricky R Reynolds on this the 17th day of May, 2013.

My Commission expires May 6, 2015

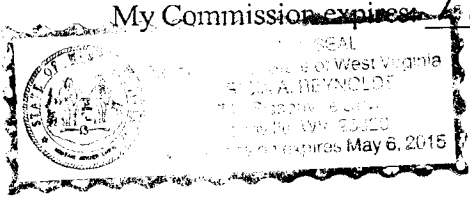

Patricia A. Reynolds
NOTARY PUBLIC, STATE AT LARGE

Please refer to Section II. Bid Conditions, Item "U" prior to completing this form.

I. GREEN PROCUREMENT

A. ENERGY

The Lexington-Fayette Urban County Government is committed to protecting our environment and being fiscally responsible to our citizens.

The Lexington-Fayette Urban County Government mandates the use of Energy Star compliant products if they are available in the marketplace (go to www.Energystar.gov). If these products are available, but not submitted in your pricing, your bid will be rejected as non-compliant.

ENERGY STAR is a government program that offers businesses and consumers energy-efficient solutions, making it easy to save money while protecting the environment for future generations.

Key Benefits

- These products use 25 to 50% less energy
- Reduced energy costs without compromising quality or performance
- Reduced air pollution because fewer fossil fuels are burned
- Significant return on investment
- Extended product life and decreased maintenance

B. GREEN SEAL CERTIFIED PRODUCTS

The Lexington-Fayette Urban County Government is also committed to using other environmentally friendly products that do not negatively impact our environment. Green Seal is a non-profit organization devoted to environmental standard setting, product certification, and public education.

Go to www.Greenseal.org to find available certified products. These products will have a reduced impact on the environment and on human health. The products to be used must be pre-approved by the LFUCG prior to commencement of any work in any LFUCG facility. If a Green Seal product is not available, the LFUCG must provide a signed waiver to use an alternate product. Please provide information on the Green Seal products being used with your bid response.

C. GREEN COMMUNITY

The Lexington-Fayette Urban County Government (LFUCG) serves as a principal, along with the University of Kentucky and Fayette County Public Schools, in the Bluegrass Partnership for a Green Community. The Purchasing Team component of the Partnership collaborates on economy of scale purchasing that promotes and enhances environmental initiatives. Specifically, when applicable, each principal is interested in obtaining best value products and/or services which promote environment initiatives via solicitations and awards from the other principals.

If your company is the successful bidder on this Invitation For Bid, do you agree to extend the same product/service pricing to the other principals of the Bluegrass Partnership for a Green Community (i.e. University of Kentucky and Fayette County Schools) if requested?

Yes No

II. Bid Conditions

- A. No bid may be withdrawn for a period of sixty (60) days after the date and time set for opening.
- B. No bid may be altered after the date and time set for opening. In the case of obvious errors, the Division of Central Purchasing may permit the withdrawal of a bid. The decision as to whether a bid may be withdrawn shall be that of the Division of Central Purchasing.
- C. Acceptance of this proposal shall be enactment of an Ordinance by the Urban County Council.
- D. The bidder agrees that the Urban County Government reserves the right to reject any and all bids for either fiscal or technical reasons, and to award each part of the bid separately or all parts to one vendor.
- E. Minor exceptions may not eliminate the bidder. The decision as to whether any exception is minor shall be entirely that of the head of the requisitioning Department or Division and the Director of the Division of Central Purchasing. The Urban County Government may waive technicalities and informalities where such waiver would best serve the interests of the Urban County Government.
- F. Manufacturer's catalogue numbers, trade names, etc., where shown herein are for descriptive purposes and are to guide the bidder in interpreting the standard of quality, design, and performance desired, and shall not be construed to exclude proposals based on furnishing other types of materials and/or services. However, any substitution or departure proposed by the bidder must be clearly noted and described; otherwise, it will be assumed that the bidder intends to supply items specifically mentioned in this Invitation for Bids.
- G. The Urban County Government may require demonstrations of the materials proposed herein prior to acceptance of this proposal.
- H. Bids must be submitted on this form and must be signed by the bidder or his authorized representative. Unsigned bids will not be considered.
- I. Bids must be submitted prior to the date and time indicated for opening. Bids submitted after this time will not be considered.
- J. All bids mailed must be marked on the face of the envelope:

“Bid on #58-2013 – Emergency Pumps & Accessories”

and addressed to: Division of Central Purchasing
 200 East Main Street, Room 338
 Lexington, Kentucky 40507

The Lexington-Fayette Urban County Government assumes no responsibility for bids that are not addressed and delivered as indicated above. Bids that are not delivered to the Division of Central Purchasing by the stated time and date will be rejected.

- K. Bidder is requested to show both unit prices and lot prices. In the event of error, the unit price shall prevail.
- L. A certified check or Bid Bond in the amount of N/A percent of the bid price must be attached hereto. This check must be made payable to the Lexington-Fayette Urban County Government, and will be returned when the material and/or services specified herein have been delivered in accordance with specifications. In the event of failure to perform within the time period set forth in this bid, it is agreed the certified check may be cashed and the funds retained by the Lexington-Fayette Urban County Government as liquidated damages. Checks of unsuccessful bidders will be returned when the bid has been awarded.
- M. The delivery dates specified by bidder may be a factor in the determination of the successful bidder.
- N. Tabulations of bids received may be mailed to bidders. Bidders requesting tabulations must enclose a stamped, self-addressed envelope with the bid.
- O. The Lexington-Fayette Urban County Government is exempt from Kentucky Sales Tax and Federal Excise Tax on materials purchased from this bid invitation. Materials purchased by the bidder for construction projects are not tax exempt and are the sole responsibility of the bidder.
- P. All material furnished hereunder must be in full compliance with OSHA regulations.
- Q. If more than one bid is offered by one party, or by any person or persons representing a party, all such bids shall be rejected.
- R. Signature on the face of this bid by the Bidder or his authorized representative shall be construed as acceptance of and compliance with all terms and conditions contained herein.
- S. The Entity (regardless of whether construction contractor, non-construction contractor or supplier) agrees to provide equal opportunity in employment for all qualified persons, to prohibit discrimination in employment because of race, color, creed, national origin, sex or age, and to promote equal employment through a positive, continuing program from itself and each of its sub-contracting agents. This program of equal employment opportunity shall apply to every aspect of its employment policies and practices.
- T. The Kentucky Equal Employment Opportunity Act of 1978 (KRS 45.560-45.640) requires that any county, city, town, school district, water district, hospital district, or other political subdivision of the state shall include in

directly or indirectly publicly funded contracts for supplies, materials, services, or equipment hereinafter entered into the following provisions:

During the performance of this contract, the contractor agrees as follows:

- (1) The contractor will not discriminate against any employee or applicant for employment because of race, color, religion, sex, age or national origin;*
- (2) The contractor will state in all solicitations or advertisements for employees placed by or on behalf of the contractors that all qualified applicants will receive consideration for employment without regard to race, color, religion, sex, age or national origin;*
- (3) The contractor will post notices in conspicuous places, available to employees and applicants for employment, setting forth the provisions of the non-discrimination clauses required by this section; and*
- (4) The contractor will send a notice to each labor union or representative of workers with which he has a collective bargaining agreement or other contract or understanding advising the labor union or workers' representative of the contractor's commitments under the nondiscrimination clauses.*

The Act further provides:

KRS 45.610. Hiring minorities - Information required

- (1) For the length of the contract, each contractor shall hire minorities from other sources within the drawing area, should the union with which he has collective bargaining agreements be unwilling to supply sufficient minorities to satisfy the agreed upon goals and timetable.*
- (2) Each contractor shall, for the length of the contract, furnish such information as required by KRS 45.560 to KRS 45.640 and by such rules, regulations and orders issued pursuant thereto and will permit access to all books and records pertaining to his employment practices and work sites by the contracting agency and the department for purposes of investigation to ascertain compliance with KRS 45.560 to 45.640 and such rules, regulations and orders issued pursuant thereto.*

KRS 45.620. Action against contractor - Hiring of minority contractor or subcontractor

- (1) If any contractor is found by the department to have engaged in an unlawful practice under this chapter during the course of performing under a contract or subcontract covered under KRS 45.560 to 45.640, the department shall so certify to the contracting agency and such certification shall be binding upon the contracting agency unless it is*

reversed in the course of judicial review.

- (2) *If the contractor is found to have committed an unlawful practice under KRS 45.560 to 45.640, the contracting agency may cancel or terminate the contract, conditioned upon a program for future compliance approved by the contracting agency and the department. The contracting agency may declare such a contractor ineligible to bid on further contracts with that agency until such time as the contractor complies in full with the requirements of KRS 45.560 to 45.640.*
- (3) *The equal employment provisions of KRS 45.560 to 45.640 may be met in part by a contractor by subcontracting to a minority contractor or subcontractor. For the provisions of KRS 45.560 to 45.640, a minority contractor or subcontractor shall mean a business that is owned and controlled by one or more persons disadvantaged by racial or ethnic circumstances.*

KRS 45.630 Termination of existing employee not required, when

Any provision of KRS 45.560 to 45.640 notwithstanding, no contractor shall be required to terminate an existing employee upon proof that that employee was employed prior to the date of the contract.

KRS 45.640 Minimum skills

Nothing in KRS 45.560 to 45.640 shall require a contractor to hire anyone who fails to demonstrate the minimum skills required to perform a particular job.

It is recommended that all of the provisions above quoted to be included as special conditions in each contract. In the case of a contract exceeding \$250,000, the contractor is required to furnish evidence that his work-force in Kentucky is representative of the available work-force in the area from which he draws employees, or to supply an Affirmative Action plan which will achieve such representation during the life of the contract.

- U. Any party, firm or individual submitting a proposal pursuant to this invitation must be in compliance with the requirements of the Lexington-Fayette Urban County Government regarding taxes and fees before they can be considered for award of this invitation and must maintain a "current" status with regard to those taxes and fees throughout the term of the contract. The contractor must be in compliance with Chapter 13 from the Code of Ordinances of the Lexington-Fayette Urban County Government. The contractor must be in compliance with Ordinance 35-2000 pursuant to contractor registration with the Division of Building Inspection. If applicable, said business must have a Fayette County business license.

Pursuant to KRS 45A.343 and KRS 45A.345, the contractor shall

- (1) *Reveal any final determination of a violation by the contractor within the previous five year period pursuant to KRS Chapters 136 (corporation and utility taxes), 139 (sales and use taxes), 141 (income taxes), 337 (wages and hours), 338 (occupational safety and health of employees), 341 (unemployment and compensation) and 342 (labor and human rights) that apply to the contractor; and*
- (2) *Be in continuous compliance with the above-mentioned KRS provisions that apply to the contractor for the duration of the contract.*

A contractor's failure to reveal the above or to comply with such provisions for the duration of the contract shall be grounds for cancellation of the contract and disqualification of the contractor from eligibility for future contracts for a period of two (2) years.

- V. Vendors who respond to this invitation have the right to file a notice of contention associated with the bid process or to file a notice of appeal of the recommendation made by the Director of Central Purchasing resulting from this invitation.

Notice of contention with the bid process must be filed within 3 business days of the bid/proposal opening by (1) sending a written notice, including sufficient documentation to support contention, to the Director of the Division of Central Purchasing or (2) submitting a written request for a meeting with the Director of Central Purchasing to explain his/her contention with the bid process. After consulting with the Commissioner of Finance the Chief Administrative Officer and reviewing the documentation and/or hearing the vendor, the Director of Central Purchasing shall promptly respond in writing findings as to the compliance with bid processes. If, based on this review, a bid process irregularity is deemed to have occurred the Director of Central Purchasing will consult with the Commissioner of Finance, the Chief Administrative Officer and the Department of Law as to the appropriate remedy.

Notice of appeal of a bid recommendation must be filed within 3 business days of the bid recommendation by (1) sending a written notice, including sufficient documentation to support appeal, to the Director, Division of Central Purchasing or (2) submitting a written request for a meeting with the Director of Central Purchasing to explain his appeal. After reviewing the documentation and/or hearing the vendor and consulting with the Commissioner of Finance and the Chief Administrative Officer, the Director of Central Purchasing shall in writing, affirm or withdraw the recommendation.

III. Procurement Contract Bid Conditions

A. The terms of this agreement shall be for 1 year from the date of acceptance of this contract by the Lexington-Fayette Urban County Government. This agreement may be extended for an additional 2 (1) year renewals upon the written agreement of the bidder and the Lexington-Fayette Urban County Government. Said agreement must be in writing and must be executed prior to the expiration of the current agreement.

B. Price Changes (**Space Checked Applies**)

() 1. Prices quoted in response to the Invitation shall be firm prices for the first 90 days of the Procurement Contract. After 90 days, prices may be subject to revision and such changes shall be based on general industry changes. Revision may be either increases or decreases and may be requested by either party. There will be no more than one (1) price adjustment per quarter. Requests for price changes shall be received in writing at least twenty (20) days prior to the effective date and are subject to written acceptance before becoming effective. Proof of the validity of a request for revision shall be responsibility of the requesting party. The Lexington-Fayette Urban County Government shall receive the benefit of any decline that the seller shall offer his other accounts.

(XXX) 2. Requests for price changes will only be allowed at the time of contract renewal. Requests shall be received in writing at least twenty (20) days prior to the effective date and are subject to written acceptance before becoming effective. Proof of the validity of a request for revision shall be responsibility of the requesting party. The Lexington-Fayette Urban County Government shall receive the benefit of any decline that the seller shall offer his other accounts.

() 3. Procurement Level Contract

C. If any contract item is not available from the vendor, the Lexington-Fayette Urban County Government, at its option, may permit the item to be back-ordered or may procure the item on the open market.

D. All invoices must bear reference to the Lexington-Fayette Urban County Government Purchasing document numbers which are being billed.

E. This contract may be canceled by either party thirty (30) days after delivery by

canceling party of written notice of intent to cancel to the other contracting party.

- F. This contract may be canceled by the Lexington-Fayette Urban County Government if it is determined that the Bidder has failed to perform under the terms of this agreement, such cancellation to be effective upon receipt of written notice of cancellation by the Bidder.
- G. No substitutions for articles specified herein may be made without prior approval of the Division of Central Purchasing.

GENERAL PROVISIONS OF BID CONTRACT

By signing the below, bidder acknowledges that it understands and agrees with the following provisions related to its bid response and the provision of any goods or services to LFUCG upon selection by LFUCG pursuant to the bid request:

1. Bidder shall comply with all Federal, State & Local regulations concerning this type of service or good.
2. Failure to submit ALL forms and information required by LFUCG may be grounds for disqualification.
3. Addenda: All addenda, if any, must be considered by the bidder in making its response, and such addenda shall be made a part of the requirements of the bid contract. Before submitting a bid response, it is incumbent upon bidder to be informed as to whether any addenda have been issued, and the failure of the bidder to cover any such addenda may result in disqualification of that response.
4. Bid Reservations: LFUCG reserves the right to reject any or all bid responses, to award in whole or part, and to waive minor immaterial defects in proposals. LFUCG may consider any alternative proposal that meets its basic needs.
5. Liability: LFUCG is not responsible for any cost incurred by bidder in the preparation of its response.
6. Changes/Alterations: Bidder may change or withdraw a proposal at any time prior to the opening; however, no oral modifications will be allowed. Only letters, or other formal written requests for modifications or corrections of a previously submitted proposal which is addressed in the same manner as the bid response, and received by LFUCG prior to the scheduled closing time for receipt of bids, will be accepted. The bid response when opened, will then be corrected in accordance with such written request(s), provided that the written request is contained in a sealed envelope which is plainly marked "modifications of bid response".
7. Clarification of Submittal: LFUCG reserves the right to obtain clarification of any point in a bid or to obtain additional information from any bidder.
8. Bribery Clause: By his/her signature on its response, bidder certifies that no employee of his/hers, any affiliate or subcontractor, has bribed or attempted to bribe an officer or employee of the LFUCG.
9. Additional Information: While not necessary, the bidder may include any product brochures, software documentation, sample reports, or other documentation that may assist LFUCG in better understanding and evaluating the bid response. Additional documentation shall not serve as a substitute for other documentation which is required by

the LFUCG to be submitted with the bid response.

10. **Ambiguity, Conflict or other Errors:** If a bidder discovers any ambiguity, conflict, discrepancy, omission or other error in the bid request of LFUCG, it shall immediately notify LFUCG of such error in writing and request modification or clarification of the document if allowable by the LFUCG.
11. **Agreement to Bid Terms:** In submitting its bid response, the bidder agrees that it has carefully examined the specifications and all provisions relating to LFUCG's bid request, including but not limited to the bid contract. By submission of its bid response, bidder states that it understands the meaning, intent and requirements of LFUCG's bid request and agrees to the same. The successful bidder shall warrant that it is familiar with and understands all provisions herein and shall warrant that it can comply with them. No additional compensation to bidder shall be authorized for services, expenses, or goods reasonably covered under these provisions that the bidder omits from its bid response.
12. **Cancellation:** LFUCG may unilaterally terminate the bid contract with the selected bidder(s) at any time, with or without cause, by providing at least thirty (30) days advance written notice unless a different advance written notice period is negotiated prior to contract approval. Payment for services or goods received prior to termination shall be made by the LFUCG provided these goods or services were provided in a manner acceptable to the LFUCG. Payment for those goods and services shall not be unreasonably withheld.
13. **Assignment of Contract:** The selected bidder(s) shall not assign or subcontract any portion of the bid contract with LFUCG without the express written consent of LFUCG. Any purported assignment or subcontract in violation hereof shall be void. It is expressly acknowledged that LFUCG shall never be required or obligated to consent to any request for assignment or subcontract; and further that such refusal to consent can be for any or no reason, fully within the sole discretion of LFUCG.
14. **No Waiver:** No failure or delay by LFUCG in exercising any right, remedy, power or privilege hereunder, nor any single or partial exercise thereof, nor the exercise of any other right, remedy, power or privilege shall operate as a waiver hereof or thereof. No failure or delay by LFUCG in exercising any right, remedy, power or privilege under or in respect of this bid proposal or bid contract shall affect the rights, remedies, powers or privileges of LFUCG hereunder or shall operate as a waiver thereof.
15. **Authority to do Business:** Each bidder must be authorized to do business under the laws of the Commonwealth of Kentucky and must be in good standing and have full legal capacity to provide the goods or services specified in the bid proposal. Each bidder must have all necessary right and lawful authority to submit the bid response and enter into the bid contract for the full term hereof including any necessary corporate or other action authorizing the bidder to submit the bid response and enter into this bid contract. If requested, the bidder will provide LFUCG with a copy of a corporate resolution authorizing this action and/or a letter from an attorney confirming that the proposer is

authorized to do business in the Commonwealth of Kentucky. All bid responses must be signed by a duly authorized officer, agent or employee of the bidder.

16. **Governing Law:** This bid request and bid contract shall be governed by and construed in accordance with the laws of the Commonwealth of Kentucky. In the event of any proceedings regarding this matter, the bidder agrees that the venue shall be the Fayette County Circuit Court or the U.S. District Court for the Eastern District of Kentucky, Lexington Division and that the bidder expressly consents to personal jurisdiction and venue in such Court for the limited and sole purpose of proceedings relating to these matters or any rights or obligations arising thereunder.
17. **Ability to Meet Obligations:** Bidder affirmatively states that there are no actions, suits or proceedings of any kind pending against bidder or, to the knowledge of the bidder, threatened against the bidder before or by any court, governmental body or agency or other tribunal or authority which would, if adversely determined, have a materially adverse effect on the authority or ability of bidder to perform its obligations under this bid response or bid contract, or which question the legality, validity or enforceability hereof or thereof.
18. Bidder understands and agrees that its employees, agents, or subcontractors are not employees of LFUCG for any purpose whatsoever. Bidder is an independent contractor at all times related to the bid response or bid contract.
19. If any term or provision of this bid contract shall be found to be illegal or unenforceable, the remainder of the contract shall remain in full force and such term or provision shall be deemed stricken.

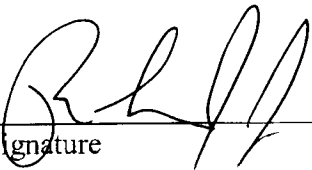
Signature

5-19-13
Date

**RISK MANAGEMENT PROVISIONS
INSURANCE AND INDEMNIFICATION**

Bid #58-2013 – Emergency Pumps & Accessories

INDEMNIFICATION AND HOLD HARMLESS PROVISION

- (1) It is understood and agreed by the parties that Vendor hereby assumes the entire responsibility and liability for any and all damages to persons or property caused by or resulting from or arising out of any act or omission on the part of Vendor or its employees, agents, servants, owners, principals, licensees, assigns or subcontractors of any tier (hereinafter "Vendor") under or in connection with this agreement and/or the provision of goods or services and the performance or failure to perform any work required thereby.
- (2) Vendor shall indemnify, save, hold harmless and defend the Lexington-Fayette Urban County Government and its elected and appointed officials, employees, agents, volunteers, and successors in interest (hereinafter "LFUCG") from and against all liability, damages, and losses, including but not limited to, demands, claims, obligations, causes of action, judgments, penalties, fines, liens, costs, expenses, interest, defense costs and reasonable attorney's fees that are in any way incidental to or connected with, or that arise or are alleged to have arisen, directly or indirectly, from or by Vendor's performance or breach of the agreement and/or the provision of goods or services provided that: (a) it is attributable to personal injury, bodily injury, sickness, or death, or to injury to or destruction of property (including the loss of use resulting therefrom), or to or from the negligent acts, errors or omissions or willful misconduct of the Vendor; and (b) not caused solely by the active negligence or willful misconduct of LFUCG.
- (3) In the event LFUCG is alleged to be liable based upon the above, Vendor shall defend such allegations and shall bear all costs, fees and expenses of such defense, including but not limited to, all reasonable attorneys' fees and expenses, court costs, and expert witness fees and expenses, using attorneys approved in writing by LFUCG, which approval shall not be unreasonably withheld.
- (4) These provisions shall in no way be limited by any financial responsibility or insurance requirements, and shall survive the termination of this agreement.

FINANCIAL RESPONSIBILITY

BIDDER/VENDOR understands and agrees that it shall, prior to final acceptance of its bid and the commencement of any work, demonstrate the ability to assure compliance with the above Indemnity provisions and these other risk management provisions.

INSURANCE REQUIREMENTS

YOUR ATTENTION IS DIRECTED TO THE INSURANCE REQUIREMENTS BELOW, AND YOU MAY NEED TO CONFER WITH YOUR INSURANCE AGENTS, BROKERS, OR CARRIERS TO DETERMINE IN ADVANCE OF SUBMISSION OF A RESPONSE THE AVAILABILITY OF THE INSURANCE COVERAGES AND ENDORSEMENTS REQUIRED HEREIN. IF YOU FAIL TO COMPLY WITH THE INSURANCE REQUIREMENTS BELOW, YOU MAY BE DISQUALIFIED FROM AWARD OF THE CONTRACT.

Required Insurance Coverage

Vendor shall procure and maintain for the duration of this contract the following or equivalent insurance policies at no less than the limits shown below and cause its subcontractors to maintain similar insurance with limits acceptable to LFUCG in order to protect LFUCG against claims for injuries to persons or damages to property which may arise from or in connection with the provision of equipment or goods or the performance of the work or services hereunder by Vendor. The cost of such insurance shall be included in any bid:

<u>Coverage</u>	<u>Limits</u>
General Liability (Insurance Services Office Form CG 00 01)	\$1 million per occurrence, \$2 million aggregate or \$2 million combined single limit
Commercial Automobile Liability (Insurance Services Office Form CA 0001)	combined single, \$1 million per occurrence
Worker's Compensation	Statutory
Employer's Liability	\$500,000.00

The policies above shall contain the following conditions:

- a. All Certificates of Insurance forms used by the insurance carrier shall be properly filed and approved by the Department of Insurance for the Commonwealth of Kentucky. LFUCG shall be named as an additional insured in the General Liability Policy and Commercial Automobile Liability Policy using the Kentucky DOI approved forms.
- b. The General Liability Policy shall be primary to any insurance or self-insurance retained by LFUCG.
- c. The General Liability Policy shall include a Products Liability endorsement unless it is deemed not to apply by LFUCG.
- d. LFUCG shall be provided at least 30 days advance written notice via certified mail, return receipt requested, in the event any of the required policies are canceled or non-renewed.
- e. Said coverage shall be written by insurers acceptable to LFUCG and shall be in a form acceptable to LFUCG. Insurance placed with insurers with a rating classification of no less than Excellent (A or A-) and a financial size category of no less than VIII, as defined by the most current Best's Key Rating Guide shall be deemed automatically acceptable.

Renewals

After insurance has been approved by LFUCG, evidence of renewal of an expiring policy must be submitted to LFUCG, and may be submitted on a manually signed renewal endorsement form. If the policy or carrier has changed, however, new evidence of coverage must be submitted in accordance with these Insurance Requirements.

Deductibles and Self-Insured Programs

IF YOU INTEND TO SUBMIT A SELF-INSURANCE PLAN IT MUST BE FORWARDED TO LEXINGTON-FAYETTE URBAN COUNTY GOVERNMENT, DIVISION OF RISK MANAGEMENT, 200 EAST MAIN STREET, LEXINGTON, KENTUCKY 40507 NO LATER THAN A MINIMUM OF FIVE (5) WORKING DAYS PRIOR TO THE RESPONSE DATE. Self-insurance programs, deductibles, and self-insured retentions in insurance policies are subject to separate approval by Lexington-Fayette Urban County Government's Division of Risk Management, upon

review of evidence of Vendor's financial capacity to respond to claims. Any such programs or retentions must provide LFUCG with at least the same protection from liability and defense of suits as would be afforded by first-dollar insurance coverage. If Vendor satisfies any portion of the insurance requirements through deductibles, self-insurance programs, or self-insured retentions, Vendor agrees to provide Lexington-Fayette Urban County Government, Division of Risk Management, the following data prior to the final acceptance of bid and the commencement of any work:

- a. Latest audited financial statement, including auditor's notes.
- b. Any records of any self-insured trust fund plan or policy and related accounting statements.
- c. Actuarial funding reports or retained losses.
- d. Risk Management Manual or a description of the self-insurance and risk management program.
- e. A claim loss run summary for the previous five (5) years.
- f. Self-Insured Associations will be considered.

Verification of Coverage

Vendor agrees to furnish LFUCG with all applicable Certificates of Insurance signed by a person authorized by the insurer to bind coverage on its behalf prior to final award, and if requested, shall provide LFUCG copies of all insurance policies, including all endorsements.

Right to Review, Audit and Inspect

Vendor understands and agrees that LFUCG may review, audit and inspect any and all of its records and operations to insure compliance with these Insurance Requirements.

DEFAULT

Vendor understands and agrees that the failure to comply with any of these insurance, safety, or loss control provisions shall constitute default and that LFUCG may elect at its option any single remedy or penalty or any combination of remedies and penalties, as available, including but not limited to purchasing insurance and charging Vendor for any such insurance premiums purchased, or suspending or terminating the work.

00389412

BID SCHEDULE

Bid #58-2013

The LFUCG is now requesting bids for the purpose of establishing a **Unit Price Contract** for **Emergency Pumps and Accessories** for the Division of Water Quality as per the attached specifications and documents with the time set forth therein, and at the unit prices stated below. This contract is for equipment only. Unit prices shall include all items and directions as stated in the Specifications including the delivery of the pump and appurtenances to 301 Lisle Industrial Avenue, Lexington, KY 40511.

The winning Bidder must provide delivery of the unit(s) within 60 days of receipt of purchase order. To assist the bidder in pricing, it is the intent of LFUCG to purchase two (2) trailer mounted portable trash pump systems for fiscal year 2013 (FY13), two (2) systems for FY14, and two (2) systems for FY15 as well as various accessories on an "as needed" basis.

Bidder must complete all items in the following schedule, including the column titled "Item total" and the "Total BID Amount (Items 1 through 52)" to be considered. Bid will be awarded to one (1) bidder ONLY.

Terms of this contract shall be for one (1) year with an option to renew for two (2) additional (1) year terms as stipulated on page 10 "Procurement Contract Bid Conditions".

Item	Estimated Quantity	Description	Size	Unit Price	Item Total
1	1	3" Portable Trash Pump	3"x3"	\$ 23,360	\$ 23,360.00
2	1	4" Portable Trash Pump	4"x4"	\$ 27,600	\$ 27,600.00
7	100ft	3" Suction Hose – 10 ft Sections with Bauer Couplings (1-Ball S77 with S2 Lever Closure Ring) (1-S78 Hose Coupling Socket) Both with Stainless Steel Clamps	3"	\$ 91.03	\$ 910.30
8	500ft	3" Discharge Hose – 50 ft Sections with Bauer Couplings (1-Ball S77 with S2 Lever Closure Ring) (1-S78 Hose Coupling Socket) Both with Stainless Steel Clamps	3"	\$ 186.41	\$ 1864.10
9	3	Bauer HK S" Bend S18	3"	\$ 39.94	\$ 119.82
10	3	Bauer HK 90° Bend S11	3"	\$ 19.42	\$ 58.26
11	4	Bauer HK 60° Bend S12	3"	\$ 18.79	\$ 75.16
12	3	Bauer HK Reducer S81	3"/2"	\$ 15.04	\$ 45.12
13	3	Bauer HK Enlarger S82	2"/3"	\$ 16.28	\$ 48.84
14	3	Bauer HK Enlarger S82	3"/4"	\$ 25.52	\$ 76.56
15	6	Bauer HK Lever Closure Ring S2	3"	\$ 6.73	\$ 40.38

Item	Estimated Quantity	Description	Size	Unit Price	Item Total
16	12	Bauer HK Rubber Sealing Ring S4	3"	\$ 0.73	\$ 8.76
17	2	Bauer HK Ball with Thread S74	3"	\$ 24.04	\$ 48.08
18	2	Bauer HK Socket with Thread S75	3"	\$ 15.49	\$ 30.98
19	4	Bauer HK Hose Coupling with Ball S77	3"	\$ 5.47	\$ 21.88
20	4	Bauer HK Hose Coupling with Socket S78	3"	\$ 5.47	\$ 21.88
21	2	Bauer HK Flanged Connection with Ball S70	3"	\$ 36.56	\$ 73.12
22	2	Bauer HK Flanged Connection with Socket S73	3"	\$ 31.56	\$ 63.12
23	100ft	4" Suction Hose - 10 ft Sections with Bauer Couplings	4"	\$ 139.00	\$ 1390.00
		(1-Ball S77 with S2 Lever Closure Ring) (1-S78 Hose Coupling Socket)		\$ inc	\$ inc
		Both with Stainless Steel Clamps		\$ inc	\$ inc
24	500ft	4" Discharge Hose - 50 ft Sections with Bauer Couplings	4"	\$ 336.18	\$ 3,361.80
		(1-Ball S77 with S2 Lever Closure Ring) (1-S78 Hose Coupling Socket)			
		Both with Stainless Steel Clamps			
25	3	Bauer HK S" Bend S18	4"	\$ 96.30	\$ 288.90
26	3	Bauer HK 90° Bend S11	4"	\$ 32.88	\$ 98.64
27	4	Bauer HK 60° Bend S12	4"	\$ 32.89	\$ 131.56
28	3	Bauer HK Reducer S81	4"/3"	\$ 26.39	\$ 79.17
29	3	Bauer HK Enlarger S82	4"/6"	\$ 49.33	\$ 147.99
30	6	Bauer HK Lever Closure Ring S2	4"	\$ 11.35	\$ 68.10
31	12	Bauer HK Rubber Sealing Ring S4	4"	\$ 1.09	\$ 13.08
32	2	Bauer HK Ball with Thread S74	4"	\$ 17.93	\$ 35.86
33	2	Bauer HK Socket with Thread S75	4"	\$ 18.47	\$ 36.94
34	4	Bauer HK Hose Coupling with Ball S77	4"	\$ 8.76	\$ 35.04
35	4	Bauer HK Hose Coupling with Socket S78	4"	\$ 9.07	\$ 36.28
36	2	Bauer HK Flanged Connection with Ball S70	4"	\$ 44.78	\$ 89.56
37	2	Bauer HK Flanged Connection with Socket S73	4"	\$ 32.64	\$ 65.28
38	100ft	6" Suction Hose -10 ft Sections with Bauer Couplings	6"	\$ 247.86	\$ 2,478.60
		(1- Ball S77 with S2 Lever Closure Ring) (1-S78 Hose Coupling Socket)			
		Both with Stainless Steel Clamps			
39	500ft	6" Discharge Hose - 50 ft sections with Bauer Couplings	6"	\$ 455.92	\$ 4,559.20
		(1-Ball S77 with S2 Lever Closure Ring) (1-S78 Hose coupling Socket)			
		Both with Stainless Steel Clamps			
40	3	Bauer HK S" Bend S18	6"	\$ 166.38	\$ 499.14
41	3	Bauer HK 90° Bend S11	6"	\$ 93.96	\$ 281.88

Item	Estimated Quantity	Description	Size	Unit Price	Item Total
42	4	Bauer HK 60° Bend S12	6"	\$ 93.96	\$ 375.84
43	2	Bauer HK Reducer S81	6"x 4"	\$ 48.38	\$ 96.76
44	2	Bauer HK Enlarger S82	6"x 8"	\$ 123.54	\$ 247.08
45	6	Bauer HK Lever Closure Ring S2	6"	\$ 22.86	\$ 137.16
46	12	Bauer HK Rubber Sealing Ring S4	6"	\$ 2.27	\$ 27.24
47	2	Bauer HK Ball with Thread S74	6"	\$ 38.59	\$ 77.18
48	2	Bauer HK Socket with Thread S75	6"	\$ 38.75	\$ 77.50
49	4	Bauer HK Hose Coupling with Ball S77	6"	\$ 16.04	\$ 64.16
50	4	Bauer HK Hose Coupling with Socket S78	6"	\$ 16.04	\$ 64.16
51	2	Bauer HK Flanged Connection with Ball S70	6"	\$ 91.61	\$ 183.22
52	2	Bauer HK Flanged Connection with Socket S73	6"	\$ 69.68	\$ 139.36
Total Bid (Items 1 through 52)				\$53,881.38	\$69,653.04

**EMERGENCY PUMPS AND ACCESSORIES
TECHNICAL SPECIFICATIONS
INDEX**

SECTION 1	GENERAL SCOPE AND SPECIAL PROVISIONS	TS-1 – TS-4
SECTION 2	TECHNICAL SPECIFICATIONS	TS-5
02531	Portable Trash Pump	02531-1 – 02531-7
02541	Trash Pump Accessories	02541-1 – 02541-2
APPENDIX A	MANUFACTURERS' PRODUCT INFORMATION	
	Godwin Suction Hose (or equal)	
	Godwin Discharge Hose (or equal)	
	Godwin Quick Disconnect (Bauer QD Pipe & Fittings) (or equal)	
	Godwin PrimeGuard Controller (or equal)	

TECHNICAL SPECIFICATIONS
SECTION 1
GENERAL SCOPE & SPECIAL PROVISIONS

The Lexington Fayette Urban County Government (LFUCG) is accepting proposals from Manufacturers / Contractors / Distributors / Vendors for the Emergency Pumps and Accessories procurement.

LFUCG provides wastewater collection and conveyance services to the general LFUCG Urban Services Area (USA), as well as limited areas outside the USA. LFUCG has established operational procedures for the continued operation of its wastewater pump stations during periods of power outages or extensive equipment failures. LFUCG's operational procedures identified nineteen (19) wastewater pump stations that will be required to be retrofitted to accommodate the pump units being supplied by these Contract Documents.

1.01 GENERAL DESCRIPTION OF SERVICES TO BE PERFORMED UNDER THIS CONTRACT:

- A. These Contract Documents are intended to provide the basis for proper unit price bidding of the Emergency Pumps and Accessories for the Owner. Anything not expressly set forth but which is reasonably implied or necessary for proper performance of these services shall be included.
- B. LFUCG will be represented by a representative of the Division of Water Quality (DWQ) including the Wastewater Collection and Conveyance Manager, the Pump Station Maintenance Supervisor, or designated representative (Engineer or On- Site Supervisor), said representative shall be authorized to initiate and oversee services under this Contract.
- C. Section 2 of the Technical Specifications includes the Specifications for the pumps and pump accessories. These Technical Specifications will be the basis for materials and equipment specified.
- D. Appendix A contains manufacturer's literature and specifications that shall be considered the basis of design for the pump accessories.
- E. The Equipment Supplier shall provide a bid for two (2) trailer mounted portable trash pump systems for fiscal year 2013 (FY13), two (2) systems for FY14, and two (2) systems for FY15. The Bid Schedule includes the items to be bid for each specified year. Unit prices for the various accessories shall be for FY13, but renewable for two (2) additional years.

1.02 SCOPE OF WORK:

This Contract provides for the Unit Price Proposal for "Emergency Pumps and Accessories" as set forth in the Bid Schedule.

1.03 CONSENT DECREE REQUIREMENTS

The work to be provided through this bid will assist the **LEXINGTON-FAYETTE URBAN COUNTY GOVERNMENT** (the "**OWNER**") in successfully implementing the **PROJECT** and complying with any requirements which are related to the Consent Decree entered in a case styled *United States & Commonwealth of Kentucky v. Lexington Fayette Urban County Government*, United States District Court for the Eastern District of Kentucky, Civil Action No. 5:06-cv-386-KSF (the "**CONSENT DECREE**"). The services provided through this bid are hereinafter referred to as the **PROJECT**. **The primary goal of the PROJECT is to provide the OWNER with the technical support and/or construction services necessary to successfully meet the obligations and deadlines of the CONSENT DECREE.**

The **BIDDER** shall familiarize itself with and shall at all times comply with the **CONSENT DECREE**, and all federal, state and local laws, ordinances, and regulations that in any manner affect the **PROJECT**. Time is of the essence in the performance of this **PROJECT**. **BIDDER** is aware that the **OWNER** is subject to penalties for non-compliance with the **CONSENT DECREE** deadlines.

If delays result solely by reason of acts of the **BIDDER**, the **BIDDER** shall be held liable for any financial penalties incurred by the **OWNER** as a result of the delay, **including but not limited to those assessed pursuant to the CONSENT DECREE**. In the event the parties cannot mutually agree upon the cause(s) associated with delays in completing project deliverables. The **BIDDER** must immediately notify the **OWNER** in the event of such delay, and provide the **OWNER** a written action plan within five (5) business days on how it will attempt to resolve the delay.

In the event that **BIDDER's** delay or other nonperformance of its obligations hereunder results in the imposition of penalties against the **OWNER** pursuant to the **CONSENT DECREE**, or the **OWNER** otherwise suffers damage as a result of such delay or nonperformance, **BIDDER** shall be solely liable to **OWNER** for any and all such damages, including any costs and attorney's fees.

1.04 GENERAL CONDITIONS:

- A. The scope of the Emergency Pumps and Accessories described in this Specification does not guarantee the quantity of equipment or materials to be purchased.
- B. LFUCG may purchase one or both pumps, and any combination of accessories in year one only, or terminate Contract to Purchase at any time with no penalty; and further

reserves the right to re-bid years 2 and/or 3 or any combination necessary to meet the needs of the Owner.

1.05 DESIGNATION OF PARTIES:

All references in the Specifications and Contract Documents to "Owner" shall mean the Lexington-Fayette Urban County Government (LFUCG); all references to "DWQ Representative" shall mean the LFUCG Division of Water Quality (DWQ) or authorized representative.

END OF SECTION

**TECHNICAL SPECIFICATIONS
SECTION 2
TECHNICAL SPECIFICATIONS**

02531 – Portable Trash Pump

02541 – Trash Pump Accessories

TECHNICAL SPECIFICATIONS
APPENDIX A
MANUFACTURERS' PRODUCT INFORMATION

Godwin Suction Hose (or equal)

Godwin Discharge Hose (or equal)

Godwin Quick Disconnect (Bauer QD Pipe & Fittings) (or equal)

Godwin PrimeGuard Controller (or equal)

02531 - PORTABLE TRASH PUMP

PART 1 - GENERAL

1.01 PROJECT SCOPE

The work to be accomplished under this section of the Specifications shall include delivery of the portable trash pumps as described below. The portable trash pumps shall be delivered to the Owner within 60 days of Contract commencement or as stated in the Notice to Proceed. Should delays occur due to manufacturing or supply, Equipment Supplier may submit for an extension of time with documentation from the manufacturer stating the delay, and a revised schedule for date of delivery.

1.02 GENERAL

- A. The Specifications herein state the minimum requirements of the OWNER. All bids must be regular in every respect. Unauthorized conditions, limitations, or provisions shall be cause for rejection. The OWNER may consider as “irregular” or “non-responsive,” any bid not prepared and submitted in accordance with the bid documents and Specification, or any bid lacking sufficient technical literature to enable the Owner to make a reasonable determination of compliance to the Specification. It shall be the Bidder’s responsibility to carefully examine each item of the Specification, failure to offer a completed bid or failure to respond to each section of the technical specification (exception yes or no) will cause the Proposal to be rejected without review as “non-responsive.” All variances, exceptions, and/or deviations shall be fully described in the appropriate section; deceit in responding to the specification will be cause for rejection.
- B. Bids will be accepted for consideration on any make and model that is equal or superior to the specified Godwin Diesel Dri-Prime pump, as interpreted by the Owner. A blanket statement that equipment proposed will meet all requirements will not be sufficient to establish equivalence, but will require an explanation of each deviation or substitution.
- C. INTERPRETATIONS: No oral interpretations will be given to any Bidder as to the meaning of the Specifications, Contract Documents, or any part thereof. Every request shall be made in writing to the Owner. Based upon such inquiry, the Owner may choose to issue an Addendum.
- D. Pumps and all appurtenances described herein shall be new, unused, and of the most current year production. Pumps shall be of the latest design and in current production completely serviced, ready for work and shall include all standard and optional equipment as specified herein.

- E. The pumps offered shall be a manufacturer's standard production model. It shall have been in continuous use by municipal and industrial owners for a minimum of five (5) years. A list of five (5) user contacts including contact names and telephone numbers must be provided with the bid submittal. Failure to supply a verifiable users list will be cause for rejection of the bid.
- E. Pumps shall be manufactured in the United States of America.
- F. Equipment Supplier must have a fully stocked parts and service facility within 200 miles of the Owner. The Owner shall have the right to inspect the office and shall be the sole judge of its adequacy to fulfill this requirement.
- G. Equipment Suppliers, on request of the Owner, must be prepared to review their specifications with the Owner and must also be prepared to provide a unit for testing. These services, if needed are considered as part of the Bidder's Proposal and will be provided without cost or obligation to the Owner.

PART 2 – PRODUCTS

2.01 SYSTEM DESCRIPTION

- A. The portable trash pump specified in this section will be used to pump raw sewage.
- B. The pump and pump accessories shall be supplied by the pump manufacturer.
- C. The pump shall be fitted with a fully automatic priming system incorporating an air compressor, air ejector assembly, and an air/water separation tank. No water shall be required in the pump to achieve a prime. The air ejector shall operate on the discharge side of the compressor, eliminating the possibility of water being drawn into the air source. The pump must be capable of running totally dry for periods up to 24 hours.
- D. The priming system shall not use a vacuum or diaphragm pump, nor require the use of a "Foot" type valve. It shall contain no moving parts or protective float gear. A demonstration of the pumps ability to repeatedly cycle from pump / snore / re-priming / pump may be required by the Owner.
- E. The diesel engine driven pump unit shall be mounted with tires that can be towed on the road at 50 MPH and shall be wired for over the road usage, per applicable DOT Standards.
- F. Pump to be fully automatic, needing no form of adjustment on priming system. It shall also be capable of operation using extended suction lines.
- G. Equipment acceptance shall be contingent upon its ability to run in a completely dry

condition for periods up to 24 continuous hours at full speed. This requires the draining of all residual water to initiate a dry suction starting condition. A demonstration may be required by the Owner.

2.02 DESIGN REQUIREMENTS

Requirement	3" Pump	4" Pump
Model (Godwin Diesel Dri-Prime Pumps)	CD80M (3")	CD103M (4")
Maximum Operating Speed, RPM	2,200	2,200
Minimum Solids Handling Size, inches	1.625	3
No. of Impeller Blades	3	2
Impeller Diameter, mm	190	256
Suction Size, inches	3	4
Discharge Size, inches	3	4
Suction and Discharge Flange Type	Raised face	Flat face
Maximum Suction Lift, feet	28	28
Shut-off Head	93	170
Primary Duty Point	125 gpm @ 40' TDH	500 gpm @ 70' TDH
Operating Range (low point)	25 gpm @ 35' TDH	300 gpm @ 135' TDH
Operating Range (high point)	300 gpm @ 45' TDH	850 gpm @ 90' TDH
O-ring Material	Buna-N	Viton
Drive Unit	Yanmar 3TNV76CSA rated at 14 HP (continuous) at 2,200 RPM	John Deere 4024T281, rated at 37 HP (continuous) at 2,000 RPM

2.03 MATERIALS AND CONSTRUCTION

- A. Pump casting shall be Class 30 cast iron. It shall be constructed so that the suction flow path is in axial alignment with the impeller eye. There shall be no turns, chambers or valves between the suction line (or inlet) and the impeller.
- B. The pump impeller shall be of open non-clog type with pump out vanes on the back. The impeller shall be of hardened cast chromium steel construction. Shrouded or semi-shrouded impellers will not be accepted.
- C. Wearplates shall be fully adjustable and replaceable fabricated of cast iron. Wearplate clearances shall have no relationship to the ability of the pump to achieve a prime. The pump wearplates shall be of a diameter equal to or greater than the impeller diameter to insure maximum protection to the pump casing. Under no circumstances will wear rings be accepted.

- D. Pump shall be fitted with a bearing bracket which contains the shaft and heavy duty ball or tapered roller bearings of adequate size to withstand imposed loads. Minimum I.S.O. L10 Bearing Life to be 100,000 hours. Impeller shafts shall be of 1½ % nickel chromium steel.
1. The 3” and 4” pumps shall have a shaft minimum diameter of 60 mm at the pump seal.
- E. The mechanical seal shall be cooled and lubricated by an oil bath reservoir, requiring no maintenance or adjustment. Pump shall be capable of running dry, with no damage, for extended periods of time. All metal seal parts shall be of stainless steel. Elastomers shall be Viton.
1. 3” Pump: Seals shall be mechanical self-adjusting type with silicon carbide faces.
 2. 4” Pump: Seals shall be high pressure, mechanical self-adjusting type with silicon carbide faces capable of withstanding suction pressures to 100 psi.
- F. Pump suction and discharge flanges shall be cast iron in accordance with ANSI (B16.1) Class 150 with face type as indicated in Part 2.02.
- G. Pump gaskets shall be compressed fiber and/or Teflon.
- H. Check valve:
1. 3” Pump: Pump shall be supplied with an integral type ball check valve, mounted on the discharge flange on the pump, to allow unrestricted flow from the impeller. The ball type check valve shall prevent in-line return of flow when the pump is shut off. Non-return valve ball and seat shall be Nitrile Rubber, and shall be field replaceable.
 2. 4” Pump: Pump shall be supplied with an integral flap check valve mounted on the discharge flange of the pump, allowing unrestricted flow into the impeller. The check valve shall prevent in-line return of flow when the pump is shut off. Non-return valve elastomers shall be Nitrile Rubber, and shall be field replaceable.
- I. Drive unit shall be a water-cooled EPA Interim Tier-4 Certified diesel engine. Engine shall drive pump by use of direct connected intermediate drive plate. Starter shall be 12 volt electric. Safety shut down switches for low oil pressure and high temperature shall be provided. Battery shall have 180 Amp hour rating. Unit shall include a tachometer and an hour meter. Unit shall as indicated in Part 2.02. A certified continuous duty engine curve shall be supplied to the Owner.

- J. Governor shall be mechanical type. Engine speed shall be adjustable to operate the pump between maximum and minimum design operation speeds.
- K. Integral trailer fuel tank capacity shall be sufficient to provide at least 24 hours of operating time at full load. The engine shall be capable of operating satisfactorily on a commercial grade of distilled No. 2 fuel oil.
- L. Exhaust system shall include muffler of suitable size from the manufacturer.
- M. The pump and engine shall be trailer mounted with a 3" Pintle ringtype trailer hitch. Tires and suspension shall be adequately sized for the required load range ratings. Trailers shall be equipped with metal fenders, front and rear support stands, lifting bar, safety chains and side and rear reflectors. Trailer design shall be in compliance with applicable DOT regulations.
- N. Pump, engine, base, and trailer shall be shop primed and finish painted at the place of manufacturer. Materials and thickness for priming shall be in accordance with manufacturer's standards. Color shall be selected by Owner from full range of Manufacturer's color palette.

2.04 AUTOMATIC STARTING CONTROL SYSTEM

- A. The engine shall be equipped with a factory installed PrimeGuard microprocessor-based pump controller as supplied by Godwin Pumps of America, Inc., or approved equal. The pump controller shall be designed to start/stop the engine at a signal supplied by high and low level floats or a 4-20 mA transducer.
- B. ENGINE / PUMP CONTROL SPECIFICATIONS
 1. The engine shall be started, stopped, and controlled by a high performance digital pump controller. The controller shall be weather proof enclosed, and contain an external weatherproof 12-position keypad accessible without the need to remove or open any protective cover or enclosure. It shall be designed to start/stop the engine at a signal supplied by high and low level floats or a 4-20 mA transducer. Engine shall be capable to start in cold weather. The pump controller shall be float controlled and provide the following functions without modification, factory recalibration or change of chips or boards by simply accessing the keypad.
 2. The keypad shall be a capacitive touch sensing system. No mechanical switches will be acceptable. The keypad shall operate in extreme temperatures, through ice, snow, mud, grease, etc. and maintain complete weather tight sealing of the pump controller panel.

3. In automatic mode, the unit shall conserve energy and go to "sleep."
4. The pump controller panel shall function interchangeably from; float switches, pressure switch, or transducer as well as manual start/stop by selection at the keypad. No other equipment or hardware changes are required.
5. The pump controller panel shall be capable of varying the engine speed to maintain a constant level in a process without a change to the panel other than via the keypad.
6. The start function can be programmed to provide 3 separate functions each day for 7 days (i.e. a start, warm up, exercise cycle on two separate days at different times and for a varying length of time all via the keypad).
7. Manual-Automatic Button
 - a. In Manual Mode, Manual "Start" button starts engine and runs until "Stop" button is depressed or an emergency shutdown occurs.
 - b. In Automatic Mode start/stop sequencing is initiated by either one-normally open or one-normally closed narrow angler float switches, pressure switch, transducer or a signal from a digital input.
8. The pump controller shall integrate the engine safety shut-off for low-oil temperature, high-temperature, and provide over-speed protection.
9. The pump controller shall include standard field adjustable parameters for engine cycle crank timer, shutdown time delay, warm-up time delay, and cool-down time delay.
10. The pump controller panel shall have only one circuit board with 8 built in relays. Each relay can be named to provide any function all via the key play without changing relays, chips, printed circuits or any hardware or software.
11. Standard components shall consist of (24) digital inputs, (7) analog inputs, (1) magnetic pick-up input, (8) 20-amp form "C" relays, (1) RS232 port, (1) RS485 port, (1) RS232/RS485 port, (1) J1939 port, and (1) 64X128 pixel full graphic LCD display with backlight.
12. The industrially hardened pump controller panel shall withstand Vibration of 3 g, 3 axis, frequency swept 10-1,000 Hz, in an operating temperature Range of 4° to 176°F (-20° to 80°C) and an operating humidity range of 0-95% Non-Condensing.

PART 3 - EXECUTION

A. MANUFACTURERER'S SERVICES

1. The manufacturer shall furnish the services of a competent factory representative to do the following:
 - a. Inspect the system prior to delivery, supervise the start up and testing of the system, and certify the system has been properly furnished and is ready for operation.
 - b. Instruct the Owner's operating personnel in the proper operation and maintenance of the system for a period of not less than one-half day.

B. TOOLS and SPARE PARTS

1. A recommended list of spare parts. (Not the actual parts themselves)

C. WARRANTY

1. The manufacturer shall furnish the following to the Owner:
 - a. A copy of the engine manufacturer's parts and labor warranty.
 - b. A one year parts and labor warranty issued by the manufacturer on the portable trash pump systems. This warranty must cover all pump parts including the mechanical seal.

END OF 02531

02541 -TRASH PUMP ACCESSORIES

PART 1 - GENERAL

1.01 SCOPE

- A. The pipe fittings and attachments will be provided along with the portable trash pumps within 60 days of Contact commencement or as stated in the Notice to Proceed.
- B. All pipe, fittings and attachments must be fully compatible with the supplied trash pumps.

PART 2 - PRODUCTS

2.1 The following items shall be provided for use for 3", 4", 6" and 8" trash pumps in the quantities requested on the Bid Schedule.

- A. 50' Heavy duty orange layflat discharge hose with quick disconnect fittings
 - 1. Nitrile rubber tube and outer cover
 - 2. Rated 300 psi (test-no fittings)
 - 3. Temperature range -36° to 210° F
 - 4. 0.1562" wall thickness
- B. 10' Heavy duty suction hose with quick disconnect fittings
 - 1. Black rubber synthetic tube and outer cover; with spiral wire helix
 - 2. Rated 28" Hg Vacuum
 - 3. Rated 150 psi (3" and 4") and 100 psi (6" and 8") (working pressure - no fittings)
 - 4. Temperature -25° to 180° F
 - 5. Wall thickness:
 - a. 3" diameter 0.305"
 - b. 4" diameter 0.305"
 - c. 6" diameter 0.4531"
 - d. 8" diameter 0.5"

C. Fittings:

1. All specified miscellaneous fittings such as bends, reducers, enlargers, couplings, and flange connections shall be Wil-loc or Bauer HK type and shall be compatible with the proposed pumps and all pump accessories. Appendix A contains manufacture's literature and specifications that shall be considered the basis of design for all fittings.

D. Large hole disconnect suction screen

1. 3" and 4" diameter 1.75" diameter holes on 3" centers
2. 6" and 8" diameter 2.5" diameter holes on 4" centers

E. Quick disconnect step bow (not applicable to 8" pumps)

F. Flanged suction adapter: ASA 150 pound flange by quick disconnect socket with o-ring

G. Flanged discharge adapter: ASA 150 pound flange by quick disconnect ball with closure ring

2.2 EQUIPMENT

A. When referring to any "Quick Disconnect" hose fittings, adapters or pipe products, the following requirement shall apply:

1. Material for pipe and fittings shall be high-tensile, cold-rolled strip steel, electrically welded, and hot galvanized with a minimum zinc coating of 500 GR/M2.
2. Working pressure shall be vacuum tight for pump suction and rated according to the following schedule:
 - a. 290 psi for 2" and 3" diameters
 - b. 175 psi for 4" through 8" diameters
3. Hydrostatic test pressure is 1.5 times the working pressure.
4. Each pipe joint shall have a ball and socket type connection, with a maximum cone of deviation up to 30°.
5. Each pipe joint shall incorporate a rubber o-ring and lever closure ring for positive sealing.

END OF 02541

Godwin Suction Hose

2" (51 mm) to 12" (305 mm) Heavy-Duty Suction Hose

Godwin Pumps* features heavy-duty suction hoses, fully vacuum rated for water, petroleum and chemical applications in sizes from 2" (51 mm) to 12" (305 mm) diameters. Available with Godwin Quick Disconnect or Camlock fittings or flanges. Ideal for water, oil and chemical applications.



Features & Benefits

- Smooth, black EPDM blend tubing
- Weather- and ozone-resistant EPDM blend cover with fabric impression
- Reinforced with synthetic fabric with wire helix
- Rated for temperatures from -25°F to +185°F
- Resistant to salt water and water-based agricultural fertilizers
- Flexible and economical

Dimensions

Inside ø " (mm)	Outside ø " (mm)	Maximum Working Pressure psi (bar)	Weight - lbs./'	Vac " Hg	Bend Radius " (mm)
2 (51)	2.49 (63)	150 (10)	1.11	28	8 (203)
3 (76)	3.5 (89)	150 (10)	2.24	28	12 (305)
4 (102)	4.53 (115)	150 (10)	2.79	28	18 (457)
6 (152)	6.54 (166)	150 (10)	5.75	28	31 (787)
8 (203)	8.79 (223)	100 (7)	6.59	28	42 (1067)
10 (254)	10.91 (277)	75 (5)	10.25	25	50 (1270)
12 (305)	12.91 (328)	75 (5)	13.5	25	60 (1524)

Home Office:
Godwin Pumps of America, Inc.
One Floodgate Road
Bridgeport, NJ 08014 USA
(856) 467-3636 • Fax: (856) 467-4841
Email: sales@godwinpumps.com
www.godwinpumps.com

godwin
pumps®

© Copyright 2007 Godwin Pumps of America, Inc.
Godwin Pumps, DrivePrime and the color orange for pumps are registered trademarks of Godwin Pumps of America, Inc.
Specifications and illustrations are subject to revision without notice. Godwin Pumps is not liable for any incompleteness or inaccuracies.
Godwin Pumps is not liable for any consequential, incidental or indirect damages relating to these specifications or their use.

Godwin Discharge Hose

2 to 12" Collapsible Layflat or Flanged High Pressure

High pressure layflat discharge hose is rugged, oil resistant hose built for the rental industry. Available with Godwin Quick Disconnect or Camlock fittings, with double bolt clamps for open discharge and medium pressure applications. Ideal for applications, including:

- General discharge, wash down, mine discharge, in-plant fire protection, irrigation connectors/boots
- Fluid transfer

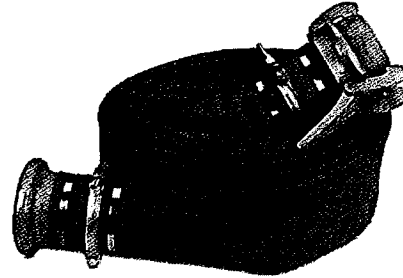

Features & Benefits

- 100% polyester circular woven reinforcement
- Nitrile rubber tube and cover with high resistance to puncture
- Three-ply double vulcanized permanently bonded cross-section
- Compact - takes up 20% less space than double jacket hoses
- Excellent service life
- MSHA approval, upon request
- Higher working pressures
- Rated for temperatures from -36°F (-38°C) to 210°F (99°C)*

* 10" (254mm) and 12" (305mm) rated for -25°F (-37°C) to 185°F (85°C)

Dimensions

ø" (mm)	Bowl Size" (mm)	Working Pressure psi (bar)	Burst psi (bar)	Weight* lbs. (kg)
2 (51)	2-3/16 (1)	240 (17)	1000 (69)	22 (10)
2½ (64)	2-13/16	240 (17)	1000 (69)	30 (13.63)
3 (76)	3-5/16	240 (17)	900 (62)	38 (17.27)
3½ (89)	3-13/16	160 (11)	700 (48)	39 (17.72)
4 (102)	4-5/16	160 (11)	700 (48)	42 (19.09)
5 (127)	5-5/16	160 (11)	600 (41)	53 (24.09)
6 (152)	6-5/16	120 (6)	500 (35)	73 (33.18)
8 (203)	8-5/16	80 (5.5)	400 (28)	125 (56.81)
10 (254)	-	100 (7)	-	270 (122.5)
12 (305)	-	100 (7)	-	338 (153.3)

* Applicable to uncoupled, 50' (15 m) lengths only.

Home Office:
Godwin Pumps
One Floodgate Road
Bridgeport, NJ 08014 USA
(856) 467-3636 • Fax: (856) 467-4841
Email: sales@godwinpumps.com
www.godwinpumps.com



Godwin Quick Disconnect Bauer QD Pipe & Fittings

Godwin features the unique Bauer pipe and adapter quick disconnect coupling system on suction hose and pipe. Fast and easy to use, the piping system can be set up in minutes, while offering the flexibility of deflection at each joint up to 30°. Strong and durable, yet lightweight, Godwin Bauer pipe is produced from high tensile strength, abrasion-resistant steel that is hot-dipped galvanized and is available in 3' (1 m), 6' (2 m), 10' (3 m) and 20' (6 m) lengths.

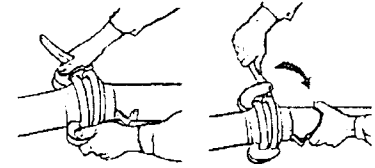

Genuine Bauer HK couplings are quickly and easily coupled/uncoupled, providing easy installation with a 30° articulation on the coupling joint.



Features & Benefits

- No tools or loose parts make for quick installation, even in the dark.
- Excellent flexibility with up to 30° articulation on coupling joint.
- Pressure-proof up to 12 bar with all types of media (subject to suitable seal material options).
- Produced from high-grade, high-tensile steel, with abrasion-resistant hot-dip galvanization, according to DIN 50976.
- Suitable for handling all types of products. Stainless steel and special coatings available as options.
- Optional special locking pin system also available.

Pipe Installation System

Genuine Bauer HK fitting pipes, hot-dip galvanized, in lengths of 3' (1 m), 6' (2 m), 10' (3 m) and 20' (6 m).

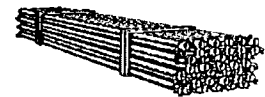
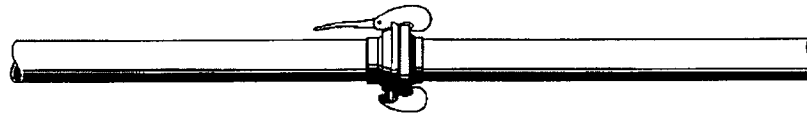



ø" (mm)	Working Pressure (psi)	Deflections (°)	3' length lbs. (kg)	6' length lbs. (kg)	10' length lbs. (kg)	20' length lbs. (kg)
2 (51)	290	30°	3.4 (1.5)	5.7 (2.6)	7.7 (3.5)	13.9 (6.3)
3 (76)	290	30°	7.5 (3.4)	11 (5)	14.8 (6.7)	23.8 (10.8)
4 (102)	175	30°	11 (5)	16.8 (7.6)	22.5 (10.2)	38.1 (17.3)
4¼ (108)			11.7 (5.3)	19 (8.6)	25.1 (11.4)	41 (18.6)
6¼ (159)	175	20°	23.1 (10.5)	33.3 (15.1)	43.9 (19.9)	74.7 (33.9)
7¾ (104)	175	20°	36.8 (16.7)	50.5 (22.9)	64.2 (29.1)	99.9 (45.3)
10 (254)	99	10°	-	-	121 (54.9)	-
12 (305)	-	10°	-	-	145 (65.8)	-

Bauer Couplings & Adapters

Hose Ends	Size" (mm)	Godwin Part #
Hose shank x ball 	2 (51)	101-1011
	3 (76)	109-1011
	4 (102)	105-1011
	6 (152)	107-1011
	8 (203)	108-1011
	10 (254)	110-1011
	12 (305)	112-1011

Hose shank x socket 	2 (51)	101-0711
	3 (76)	109-0711
	4 (102)	105-0711
	6 (152)	107-0711
	8 (203)	108-0711
	10 (254)	110-0711
	12 (305)	112-0711

Lever closure ring 	2 (51)	101-0134
	3 (76)	103-0134
	4 (102)	105-0134
	6 (152)	106-0134
	8 (203)	108-0134

Rubber sealing ring 	2 (51)	101-0140
	3 (76)	103-0140
	4 (102)	105-0140
	6 (152)	107-0140
	8 (203)	108-0140
	10 (254)	110-0140
	12 (305)	112-0140

Complete hose end coupling assembly 	2 (51)	100-6774
	3 (76)	100-6772
	4 (102)	100-6768
	6 (152)	100-6765
	8 (203)	100-6764
	10 (254)	100-6769
	12 (305)	100-6770

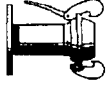
Flanged Ends	Size" (mm)	Godwin Part #
Flanged end with ball and lever 	2 (51)	100-6971
	3 (76)	100-6970
	4 (102)	100-6987
	6 (152)	100-7005
	8 (203)	100-7003
	10 (254)	110-7002
	12 (305)	112-7002

Flanged suction adapter 	2 (51)	100-6969
	3 (76)	100-6968
	4 (102)	100-6986
	6 (152)	100-7004
	8 (203)	100-7002
	10 (254)	110-7003
	12 (305)	112-7003

Screw Ends	Size" (mm)	Godwin Part #
Male NPT threaded end by male ball end 	2 (51)	101-0811
	3 (76)	109-0820
	4 (102)	105-0811
	6 (152)	107-0811
	8 (203)	108-0811
	10 (254)	110-0811
	12 (305)	112-0811

Male NPT threaded end by socket 	2 (51)	101-0511
	3 (76)	109-0521
	4 (102)	105-0511
	6 (152)	107-0511
	8 (203)	108-0511
	10 (254)	110-0511
	12 (305)	112-0511

Strainers	Size" (mm)	Godwin Part #
Large hole screen x male (with closure ring) 	2 (51)	200-9876
	3 (76)	200-9877
	4 (102)	200-9874
	6 (152)	200-9875
	8 (203)	200-9878

Pipe Bends	Size" (mm)	Godwin Part #
90° elbow 	2 (51)	101-1101
	3 (76)	109-1101
	4 (102)	152-1101
	6 (152)	159-1101
	8 (203)	160-1101
	10 (254)	110-1101
	12 (305)	112-1101

60° elbow 	2 (51)	101-1201
	3 (76)	109-1201
	4 (102)	105-1201
	6 (152)	107-1201
	8 (203)	108-1201
	10 (254)	110-1201
	12 (305)	112-1201

45° elbow 	2 (51)	100-7469
	6 (152)	100-7468
	8 (203)	100-6640

S-Bend (Step Bow) 	2 (51)	101-1501
	3 (76)	109-1501
	4 (102)	105-1501
	6 (152)	107-1501
	8 (203)	108-1501

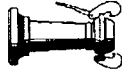
Adapters	Size" (mm)	Godwin Part #
Reducer 	3 (76) x 2 (51)	103-2701
	4 (102) x 3 (76)	105-2711
	6 (152) x 4 (102)	100-7091
	8 (203) x 6 (152)	108-2701
	10 (254) x 8 (203)	110-2701
	12 (305) x 10 (254)	112-2701

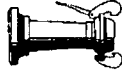
Increaser 	2 (51) x 3 (76)	101-1601
	3 (76) x 4 (102)	100-9160
	4 (102) x 6 (152)	105-1601
	6 (152) x 8 (203)	107-1601
	8 (203) x 10 (254)	108-1601

Tee and Y Adapters	Size" (mm)	Godwin Part #
End Tee male x male x female 	2 (51)	101-1901
	3 (76)	109-1901
	4 (102)	105-1901
	6 (152)	107-1901
	8 (203)	108-1901
	10 (254)	110-1901
	12 (305)	112-1901

Outlet Tee female x female x male 	2 (51)	101-1805
	3 (76)	109-1805
	4 (102)	105-1805
	6 (152)	107-1805
	8 (203)	108-1805

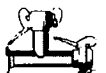
Line Tee male x female x male 	2 (51)	101-1701
	3 (76)	109-1701
	4 (102)	105-1701
	6 (152)	107-1701
	8 (203)	108-1701
	10 (254)	110-1701
	12 (305)	112-1701

Y Adapter female x female x male 	2 (51)	100-1701
	3 (76)	100-1701
	4 (102)	100-6708
	6 (152)	100-6707
	8 (203)	100-6706
	10 (254)	100-1701
	12 (305)	100-6712

Strainers	Size" (mm)	Godwin Part #
Round hole screen x male (with closure ring) 	2 (51)	200-0876
	3 (76)	200-0877
	4 (102)	200-0874
	6 (152)	200-0873
	8 (203)	200-0878

Home Office:
Godwin Pumps
One Floodgate Road
Bridgeport, NJ 08014 USA
(856) 467-3636 • Fax: (856) 467-4841
Email: sales@godwinpumps.com
www.godwinpumps.com



Godwin PrimeGuard Controller

Automation for Diesel Engines

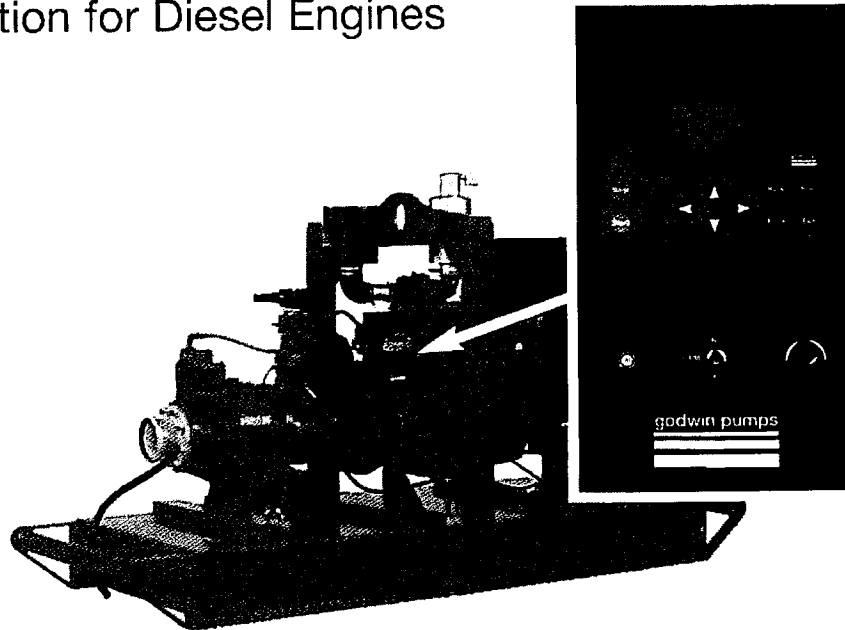

Godwin's diesel driven automatic Dri-Prime® pumps now include the Godwin PrimeGuard Automatic Level Control system on all Tier II electronic diesel engines. The Godwin PrimeGuard is a fully programmable microprocessor engine control system allowing for inputs from level, flow, pressure transducers or standard floats. Using any of these systems, your Godwin Dri-Prime® pump can start and stop automatically with no operator intervention required. Call today for more details about Automatic Level Controls for your portable/permanent pumping application.

Features

- High performance, state of the art, touch-sensing digital controller.
- No mechanical switches to wear or stick.
- Manual, automatic, or remote starting capabilities.
- Security levels allow limited to full access of controller functionality.
- Includes 8 programmable relays and 66 selectable features, including pump running, pump failure, and others.
- RS-232 and RS-485 communication ports enable communication with SCADA and other alarm equipment.
- Available as an option for non-electronic diesel engines.
- Capable of auto throttling engine rpm in response to changing pressure/level/flow transducer signals.
- Maintains an "event history" of all warning alarms (up to 32).
- User can pre-set engine rpm to maintain flow and head parameters when running unattended.
- Tracks oil and filter usage and alerts operator when replacement is recommended.
- Diesel engine warm up/cool down cycle available.

godwin
pumps

Godwin PrimeGuard Controller Basic Operation

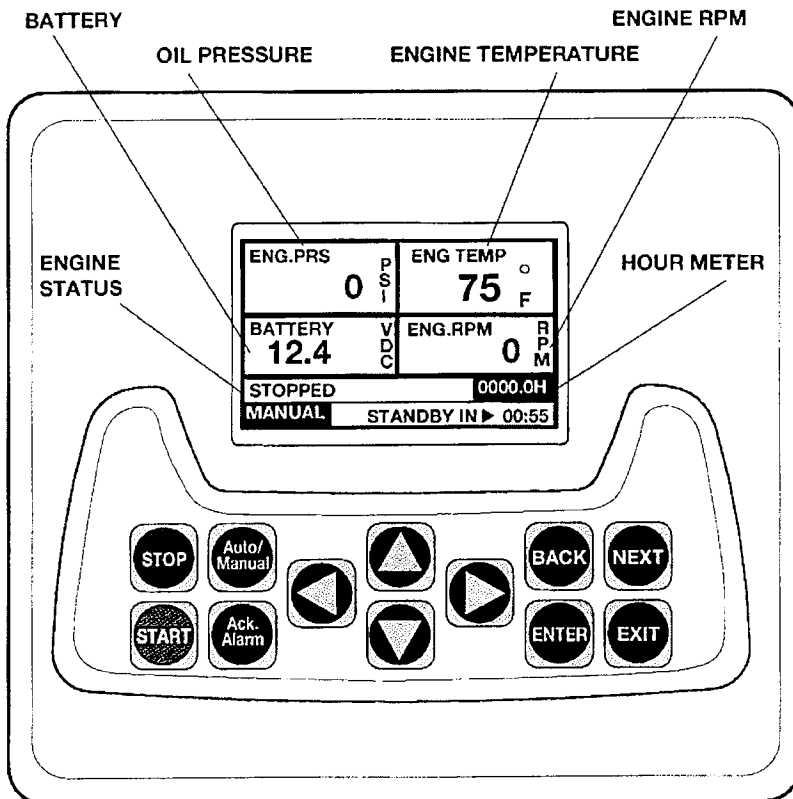

- START** One-touch engine starting
- STOP** One-touch engine stopping
- ▲** Directional arrows for data input
- Auto/Manual** Switches between auto and manual modes
- Ack. Alarm** Acknowledges alarms
- BACK** Navigates back across status screens
- NEXT** Navigates forward across status screens
- ENTER** Enters selected data
- EXIT** Exits current screen to four quadrant information screen

Default "Home" screen illustrated above.

Godwin PrimeGuard Connector Layout

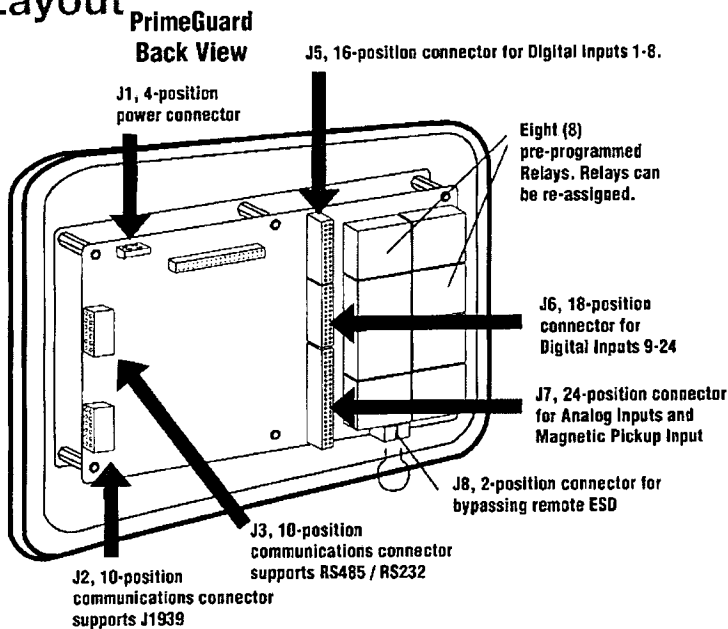

The Godwin PrimeGuard is designed to operate from any DC supply from 8-35VDC continuous.

godwin
pumps

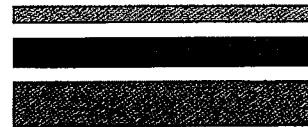

One Floodgate Road, Bridgeport, NJ 08014, USA
 (856) 467-3636 • Fax: (856) 467-4841
 Quenington, Cirencester, Glos., GL7 5BX, UK
 +44 (0)1285-750271 • Fax: +44 (0)1285-750352
 E-mail: sales@godwinpumps.com
 www.godwinpumps.com

BRANCH LOCATIONS:

Connecticut • Pennsylvania • Ohio • New York
 Illinois • Maryland • Virginia • West Virginia • Georgia
 South Carolina • North Carolina • Florida • Texas
 Montana • California • Washington

Sub-Prime® and the color orange for pumps are registered trademarks of Godwin Pumps of America, Inc. Specifications and illustrations are subject to revision without notice.

© Copyright 2004 Godwin Pumps of America, Inc. All rights reserved.

GPASL 120.1004



Godwin Dri-Prime Pump user list as requested by LFUCG for Bid specification.

- 1 – Catlettsburg Refining – Paul Christian – 606-694-4864 (Cell)
- 2 – City of Charleston – Paul Crowder – 304-348-8136 – 304-993-6055 (Cell)
- 3 – St. Albans Water & Sewer – Clayton Priddy – 304-722-3355 – 304-522-8197 (Cell)
- 4 – Winchester Municipal Utilities – Duke Dryden – 859-744-5434 – 859-595-0588 (Cell)
- 5 – Lavallette PSD – Richard Smith – 304-525-3771 – 304-544-3371 (cell)

Roger L. Jones, Jr.
Outside Sales Representative
Xylem Dewatering Solutions – Godwin Pumps
Southeastern OH, Northwestern WV---Cell: 304.541.8184
Southeastern KY, Northeastern KY---Cell: 859.338.3552
roger.jones@xylem.com



RELIABILITY. RESPONSIVENESS. REPUTATION.
Romans 10:9 John 10:9

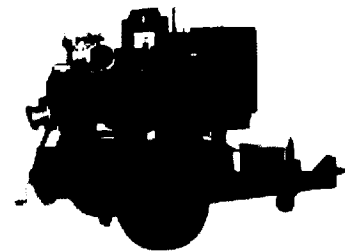

Godwin Dri-Prime 1-2 Year Recommended Spare Parts Kits

- Contain parts for minor repairs or inspections that may occur in the first 1-2 years or 2000 hours of usage.
- Enable you to have the parts on hand if the pump requires a repair.
- Priced 5-8% cheaper than buying the parts individually.

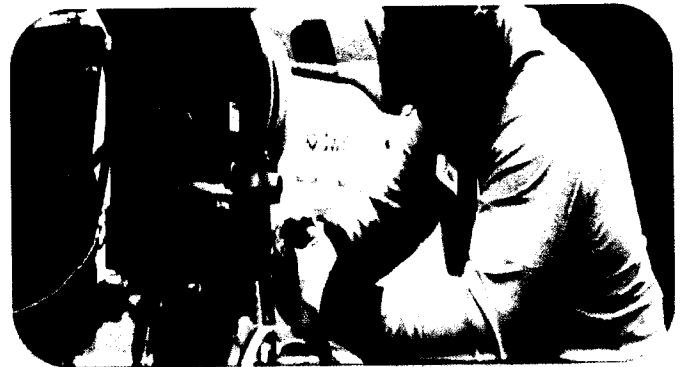
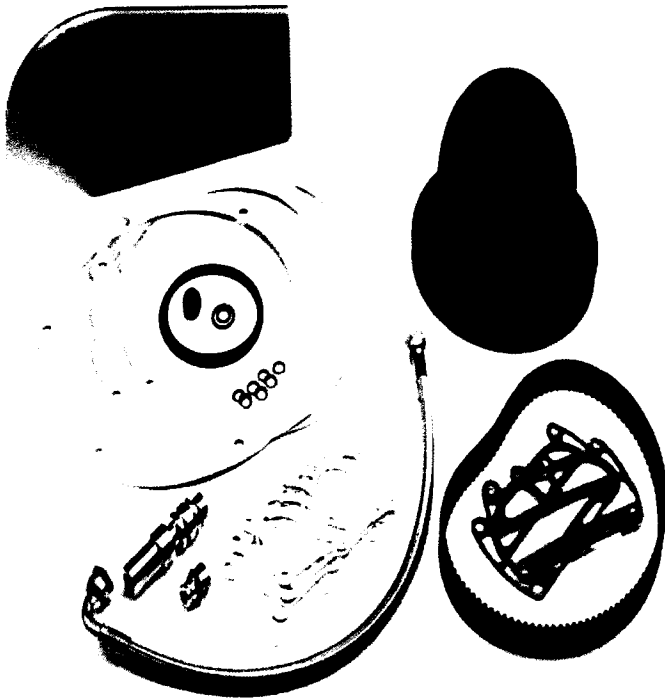

godwin 
a xylem brand

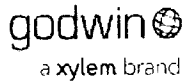

1-2 YR RECOMMENDED SPARE PARTS KITS FOR GODWIN DRI-PRIME PUMPS

KIT PRICES ARE 5-8% LESS THAN BUYING THE PARTS INDIVIDUALLY.
KITS CONTAIN PARTS FOR MOST COMMON MINOR REPAIRS OR INSPECTIONS THAT MAY OCCUR IN THE FIRST 1-2 YEARS OF OWNERSHIP.

CD/DPC MODELS

CD75MA5

KIT PART NUMBER

GPCD75MA5RS02
GPCD75MA5RS03 *
GPCD75BBS04

DIESEL OR ELECTRIC

DIESEL DRIVEN
DIESEL AND ELECTRIC
ELECTRIC DRIVEN

FITS

OPEN AND CRITICALLY SILENCED UNITS
OPEN AND CRITICALLY SILENCED UNITS
OPEN AND CRITICALLY SILENCED UNITS

LIST PRICE

\$1,075.00
\$2,632.49
\$1,150.00

ADDITIONAL NOTE

* FOR STAINLESS STEEL/CD4M UNITS

CD80D

KIT PART NUMBER

GPCD80DRS05
GPCD80DRS06

DIESEL OR ELECTRIC

DIESEL DRIVEN
ELECTRIC DRIVEN

FITS

OPEN AND CRITICALLY SILENCED UNITS
OPEN AND CRITICALLY SILENCED UNITS

LIST PRICE

\$820.00
\$820.00

ADDITIONAL NOTE

CD80M

KIT PART NUMBER

GPCD80MRS07
GPCD80MRS08

DIESEL OR ELECTRIC

DIESEL DRIVEN
ELECTRIC DRIVEN

FITS

OPEN AND CRITICALLY SILENCED UNITS
OPEN AND CRITICALLY SILENCED UNITS

LIST PRICE

\$1,600.00
\$1,400.00

ADDITIONAL NOTE

CD100M

KIT PART NUMBER

GPCD100MRS09
GPCD100MRS10 *
GPCD100MRS11
GPCD100MRS12 *

DIESEL OR ELECTRIC

DIESEL DRIVEN
DIESEL DRIVEN
ELECTRIC DRIVEN
ELECTRIC DRIVEN

FITS

OPEN AND CRITICALLY SILENCED UNITS
OPEN AND CRITICALLY SILENCED UNITS
OPEN AND CRITICALLY SILENCED UNITS
OPEN AND CRITICALLY SILENCED UNITS

LIST PRICE

\$1,200.00
\$3,800.00
\$1,150.00
\$3,750.00

ADDITIONAL NOTE

* FOR STAINLESS STEEL/CD4M UNITS

* FOR STAINLESS STEEL/CD4M UNITS

CD103M

KIT PART NUMBER

GPCD103MRS14
GPCD103MRS15 *
GPCD103MRS16

DIESEL OR ELECTRIC

DIESEL DRIVEN
DIESEL DRIVEN
ELECTRIC DRIVEN

FITS

OPEN AND CRITICALLY SILENCED UNITS
OPEN AND CRITICALLY SILENCED UNITS
OPEN AND CRITICALLY SILENCED UNITS

LIST PRICE

\$1,075.00
\$2,975.00
\$1,000.00

ADDITIONAL NOTE

* FOR STAINLESS STEEL/CD4M UNITS

CD140M

KIT PART NUMBER

GPCD140MRS17
GPCD140MRS19 *
GPCD140MRS20

DIESEL OR ELECTRIC

DIESEL DRIVEN
DIESEL DRIVEN
ELECTRIC DRIVEN

FITS

OPEN AND CRITICALLY SILENCED UNITS
OPEN AND CRITICALLY SILENCED UNITS
OPEN AND CRITICALLY SILENCED UNITS

LIST PRICE

\$1,200.00
\$3,100.00
\$1,125.00

ADDITIONAL NOTE

* FOR STAINLESS STEEL/CD4M UNITS

CD150M

KIT PART NUMBER

GPCD150MRS20
GPCD150MRS21 *
GPCD150MRS22
GPCD150MRS23
GPCD150MRS24 *

DIESEL OR ELECTRIC

DIESEL DRIVEN
DIESEL DRIVEN
DIESEL DRIVEN
ELECTRIC DRIVEN
ELECTRIC DRIVEN

FITS

OPEN UNITS
OPEN UNITS
CRITICALLY SILENCED UNITS
OPEN AND CRITICALLY SILENCED UNITS
OPEN AND CRITICALLY SILENCED UNITS

LIST PRICE

\$1,500.00
\$5,000.00
\$1,300.00
\$1,400.00
\$4,800.00

ADDITIONAL NOTE

* FOR STAINLESS STEEL/CD4M UNITS

* FOR STAINLESS STEEL/CD4M UNITS

CD160M AND CD180M

KIT PART NUMBER

GPCD160180MRS25
GPCD160180MRS26 *
GPCD160180MRS27

DIESEL OR ELECTRIC

DIESEL DRIVEN
DIESEL DRIVEN
ELECTRIC DRIVEN

FITS

OPEN AND CRITICALLY SILENCED UNITS
OPEN AND CRITICALLY SILENCED UNITS
OPEN AND CRITICALLY SILENCED UNITS

LIST PRICE

\$1,475.00
\$3,500.00
\$1,250.00

ADDITIONAL NOTE

* FOR STAINLESS STEEL/CD4M UNITS

CD200M

KIT PART NUMBER

GPCD200MRS28
GPCD200MRS29

DIESEL OR ELECTRIC

DIESEL DRIVEN
DIESEL DRIVEN

FITS

OPEN UNITS
CRITICALLY SILENCED UNITS

LIST PRICE

\$1,575.00
\$1,425.00

ADDITIONAL NOTE

CD225M

KIT PART NUMBER

GPCD225MRS30
GPCD225MRS31 *
GPCD225MRS32
GPCD225MRS33

DIESEL OR ELECTRIC

DIESEL DRIVEN
DIESEL DRIVEN
DIESEL DRIVEN
ELECTRIC DRIVEN

FITS

OPEN UNITS
OPEN UNITS
CRITICALLY SILENCED UNITS
OPEN AND CRITICALLY SILENCED UNITS

LIST PRICE

\$1,550.00
\$4,200.00
\$1,300.00
\$1,300.00

ADDITIONAL NOTE

* FOR STAINLESS STEEL/CD4M UNITS

CD250M

KIT PART NUMBER

GPCD250MRS34
GPCD250MRS30

DIESEL OR ELECTRIC

DIESEL DRIVEN
ELECTRIC DRIVEN

FITS

OPEN AND CRITICALLY SILENCED UNITS
OPEN AND CRITICALLY SILENCED UNITS

LIST PRICE

\$1,950.00
\$1,675.00

ADDITIONAL NOTE

CD300M

KIT PART NUMBER

GPCD300MRS35

DIESEL OR ELECTRIC

DIESEL AND ELECTRIC

FITS

OPEN AND CRITICALLY SILENCED UNITS

LIST PRICE

\$1,650.00

ADDITIONAL NOTE

CD400M

KIT PART NUMBER

GPCD400MRS36

DIESEL OR ELECTRIC

DIESEL AND ELECTRIC

FITS

OPEN AND CRITICALLY SILENCED UNITS

LIST PRICE

\$2,550.00

ADDITIONAL NOTE

CD500M

KIT PART NUMBER

GPCD500MRS37

DIESEL OR ELECTRIC

DIESEL AND ELECTRIC

FITS

OPEN AND CRITICALLY SILENCED UNITS

LIST PRICE

\$2,000.00

ADDITIONAL NOTE

DPC300

KIT PART NUMBER

GPDP300MRS38
GPDP300MRS39

DIESEL OR ELECTRIC

DIESEL DRIVEN
ELECTRIC DRIVEN

FITS

OPEN AND CRITICALLY SILENCED UNITS
OPEN AND CRITICALLY SILENCED UNITS

LIST PRICE

\$1,200.00
\$1,275.00

ADDITIONAL NOTE

Godwin Dri-Prime Pump Recommended Spare Parts as requested by LFUCG for Bid specification.

<u>KIT PART NUMBER</u>	<u>MODEL/CONFIGURATION</u>	<u>INCLUDES</u>			<u>LIST PRICE</u>
GPCD80MRS07	CD80M DIESEL DRIVEN OPEN OR SILENT PACK	1	2304599916	CD80M Spindle Assembly	\$1,600.00
		1	2304600125	CD80M NRV Cover	
		1	2305872016	Ejector Jet	
		1	2305882016	Ejector Nozzle	
		2	3810134112A	O-Ring	
		2	3810144112A	Ejector Nozzle O-Ring	
		1	3906414113A	Ejector Ball	
		1	2305869923	CD80-HL80 Separation Tank Filter/ Screen	
		1	3802274113	CD80M NRV Cover Gasket	
		3	3807634412	Nyltite Seal	
		1	3810044112A	Wearplate O-Ring	
		1	4307189913A	Compressor Pipe	
		2	4400369912A	Relief Valve	
		2	420H150	Belt	
		GPCD103MRS14	CD103M DIESEL DRIVEN OPEN OR SILENT PACK	1	
1	GPV4150300G			GPV4-150/300# Valve Cover Gasket	
1	2305682016			Ejector Jet	
1	2305712016			Ejector Nozzle	
1	2305869923			CD80-HL80 Separation Tank Filter/ Screen	
10	4307639912			M12 Dowty Washer	
2	3810041112A			Viton Wearplate O-Ring	
2	3810134112A			O-Ring	
2	3810144112A			Ejector Nozzle O-Ring	
1	3906414113A			Ejector Ball	
1	4316129913			Compressor Pipe	
2	4400369912A			Relief Valve	
1	390H150			Compressor Belt	
3	4905230300A			Valve Plate Gasket	
3	4905230400A			Valve Plate Gasket	
3	4905230900A	Head Gasket			

Roger L. Jones, Jr.
Outside Sales Representative
Xylem Dewatering Solutions – Godwin Pumps
Southeastern OH, Northwestern WV---Cell: 304.541.8184
Southeastern KY, Northeastern KY---Cell: 859.338.3552
roger.jones@xyleminc.com

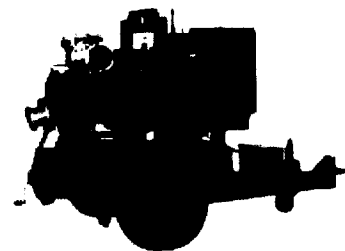

Dewatering Solutions

84 Floodgate Road, Bridgeport, NJ 08014
Tel +1.856.467.3636 Fax +1.856.467.2419

Limited Product Warranty
Godwin Dri-Prime® Pump

Subject to the terms and conditions below, Xylem Dewatering Solutions, Inc. ("Xylem") warrants that products manufactured by it (other than components subject to an OEM Warranty) (collectively, the "Products"), when used as intended and designed, shall be free from defects in material and/or workmanship for the applicable Warranty Period. Warranty coverage for new Products sold to the original owner begins on the date of shipment for a period of twelve (12) months or an accumulation of two thousand (2,000) hours of use, whichever occurs first (the "Warranty Period").

Engines, motors and driven components carry a separate manufacturer's (OEM) warranty (the "OEM Warranties"), unless otherwise expressly stated. OEM Warranties are in addition to this Warranty. All Warranty claims for defects in material and/or workmanship involving OEM components must be directed through the OEM distributor/dealer network. OEM Warranties may vary and are subject to change. Xylem shall have no liability under OEM warranties.

Warranty claims must be submitted promptly to Xylem in writing at 84 Floodgate Road, Bridgeport NJ 08014, Attn: Warranty/Service Dept., and actually received within the applicable Warranty Period, including proof of purchase and describing in detail: (i) the applicable Warranty, (ii) the claimed Product deficiency, defect or failure, (iii) Product information required by Xylem, and (iv) sales or purchase order for any replacement parts (sent to Xylem Parts Sales Department). Returns must have prior written authorization from Xylem. Purchaser's exclusive remedies under this Warranty shall be, at Xylem's sole discretion: (i) replacement parts; or (ii) credit for the approved costs for replacement parts. These remedies are expressly limited to the replacement of the defective part(s) and do not include the replacement of the entire Product. Xylem shall not be held responsible for travel expenses, rented equipment, outside contractor's fees or unauthorized repair shop expenses. Xylem neither assumes nor authorizes any person or other company to assume for it, any other obligation in connection with the sale of its equipment. Any enlargement or modification of this by a representative or other sales agent is their exclusive responsibility. Transportation charges shall be borne by the Buyer. The Warranty does not cover any incidental or consequential costs or damages, including without limitation and not necessarily limited to: shipping or associated transportation charges, travel to and from repair sites, damages related to the loss of use, lost rentals, re-rental expenses and damages to property or other equipment.

The warranty covers the above-described portable pumping equipment when used for pumping non-corrosive liquids containing limited quantities of abrasive particles in compliance with technical manuals and Company representations. This warranty shall extend only to the original owner and shall not apply to replacement of non-defective parts (such as seals, wear plates, and impellers) that may wear and need to be replaced with reasonable use within the warranty period or which may require replacement in connection with normal maintenance (such as fluids, filters, and belts). Additionally, this Warranty shall not apply to the extent Product defect has been caused by any of the following: (i) Product operator negligence or intentional misconduct (other than by Xylem), (ii) casualty or accident to the Products; (iii) use and operation of the Products not in conformance with Xylem's training and/or operation manuals, or operation exceeding Xylem ratings for the Products, including misuse and abuse;

Dewatering Solutions

84 Floodgate Road, Bridgeport, NJ 08014
Tel +1.856.467.3636 Fax +1.856.467.2419

(iv) operation, maintenance and/or service of the Products not in conformance with Xylem's recommended operation, maintenance and/or service schedules; (v) improper installation (other than by Xylem) not in material conformance with Xylem specifications; (vi) unauthorized modification of or alternations to the Products; (vii) improper load sizing (other than by Xylem); (vii) transportation damage; or (ix) Product exposure to the elements or other acts of God.

THE EXPRESS WARRANTIES PROVIDED HEREIN ARE OFFERED IN LIEU OF ALL OTHER WARRANTIES, AND TO THE GREATEST EXTENT PERMITTED BY APPLICABLE LAW, XYLEM'S REPLACEMENT OF OR CREDIT FOR DEFECTIVE PARTS AS DESCRIBED HEREIN SHALL BE PURCHASER'S SOLE AND EXCLUSIVE REMEDIES AND XYLEM SHALL HAVE NO ADDITIONAL OBLIGATIONS. XYLEM MAKES NO WARRANTY, REPRESENTATION OR GUARANTEE TO PURCHASER OR ANY THIRD PARTY EXCEPT AS EXPRESSLY PROVIDED IN AND BY THIS WARRANTY. XYLEM HEREBY EXPRESSLY DISCLAIMS ANY WARRANTY OF MERCHANTABILITY OR OF FITNESS FOR A PARTICULAR PURPOSE (OR OTHER WARRANTIES, REPRESENTATIONS OR GUARANTEES ARISING BY OPERATION OF LAW, COURSE OF DEALING OR CUSTOM OF TRADE). XYLEM SHALL NOT BECOME LIABLE UNDER ANY CIRCUMSTANCES WHATSOEVER (WHETHER BY VIRTUE OF A PURCHASE AGREEMENT, THIS WARRANTY, ANCILLARY AGREEMENTS ENTERED INTO IN CONJUNCTION WITH THE FOREGOING OR ANY OTHER DOCUMENTS) FOR SPECIAL, EXEMPLARY, CONSEQUENTIAL, INCIDENTAL, PUNITIVE OR SPECULATIVE DAMAGES, WHETHER BASED ON CONTRACT, TORT (INCLUDING NEGLIGENCE), STRICT LIABILITY OR OTHERWISE INCLUDING WITHOUT LIMITATION PURCHASER'S OR ANY THIRD PARTIES' LOST PROFITS WHICH MAY RESULT FROM, BE CAUSED BY OR ARISE OUT OF: (I) BREACH OF ANY WARRANTY, REPRESENTATION OR GUARANTEE MADE BY XYLEM; (II) THE USE, OR COST OF USE, OF THE PRODUCTS; OR (III) XYLEM'S PERFORMANCE OF ANY REMEDIAL WORK REQUIRED BY THIS WARRANTY.

This warranty applies only to Products sold within North America and South America. Some states in the United States of America do not allow limitations of how long an implied warranty extends, or the exclusion of incidental, indirect, special or consequential damages, so that the above limitation or exclusion may not apply to you. In some Canadian provinces legislation provides for certain additional warranties or remedies other than as stated herein, and to the extent that they may not be waived, the limitations and exclusions set out above may not apply. This Warranty provides specific legal rights; other rights may be available, but may vary from state to state or from province to province.
gb132608_2 10/2006.

This policy is subject to change.

JOHN DEERE NEW OFF-HIGHWAY ENGINE WARRANTY



Warranty Duration

Unless otherwise provided in writing by John Deere, John Deere* makes the following warranty to the first retail purchaser and each subsequent purchaser (if purchase is made prior to expiration of applicable warranty) of each John Deere new off-highway engine marketed as part of a product manufactured by a company other than John Deere or its affiliates and on each John Deere engine used in an off-highway repower application:

- 12 months, unlimited hours of use, or
- 24 months and prior to the accumulation of 2000 hours of use

Note: In the absence of a functional hourmeter, hours of use will be determined on the basis of 12 hours of use per calendar day.

Warranty Coverage

This warranty applies to the engine and to integral components and accessories sold by John Deere, and delivered to the first retail purchaser on or after 1 January 2001.

All John Deere-warranted parts and components of John Deere engines which, as delivered to the purchaser, are defective in materials and/or workmanship will be repaired or replaced, as John Deere elects, without charge for parts or engine repair labor, including reasonable costs of labor to remove and reinstall non-engine parts or components of the equipment in which the engine is installed, and, when required, reasonable costs of labor for engine removal and reinstallation, if such defect appears within the warranty period as measured from the date of delivery to the first retail purchaser, if the delivery is reported to John Deere within 30 days of the delivery.

Emissions Warranties

Emissions warranties appear in the operation and maintenance instructions furnished with the engine/machine.

Obtaining Warranty Service

Warranty service must be requested of the nearest authorized John Deere engine service outlet before the expiration of the warranty. An *authorized* service outlet is a John Deere engine distributor, a John Deere engine service dealer, or a John Deere equipment dealer selling and servicing equipment with an engine of the type covered by this warranty.

Authorized service outlets will use only new or remanufactured parts or components furnished or approved by John Deere.

Authorized service locations and the name of the John Deere division or subsidiary making this warranty are listed in the *Parts and Service Directory for John Deere Engines*.

At the time of requesting warranty service, the purchaser must be prepared to present evidence of the date of delivery of the engine.

John Deere reimburses authorized service outlets for limited travel expenses incurred in making warranty service repairs in non-John Deere applications when travel is actually performed. The limit, as of the date of publication of this statement, is US\$300.00 (US\$400.00 if engine is marine) or equivalent. If distances and travel times are greater than reimbursed by John Deere, the service outlet will charge the purchaser for the difference.

Warranty Exclusions

John Deere's obligations shall not apply to fuel injection pump and nozzles during the pump and nozzle manufacturer's warranty period on the pump and nozzles, components and accessories which are not furnished or installed by John Deere, nor to failures caused by such items. When the pump manufacturer's warranty is less than the engine warranty, John Deere will reimburse pump repair costs for warrantable-type failures during the remainder of the original engine warranty period, when so documented by the pump manufacturer's approved service outlet.

* "John Deere" means John Deere Power Systems with respect to users in the United States, John Deere Limited with respect to users in Canada, and Deere & Company or its subsidiary responsible for marketing John Deere equipment in other countries where the user is located.

Purchaser's Responsibilities

The cost of normal maintenance and depreciation.

Consequences of negligence, misuse, or accident involving the engine, or improper application, installation, or storage of the engine.

Consequences of service performed by someone other than a party authorized to perform warranty service, if such service, in John Deere's judgment, has adversely affected the performance or reliability of the engine.

Consequences of any modification or alteration of the engine not approved by John Deere, including, but not limited to, tampering with fuel and air delivery systems.

The effects of cooling system neglect as manifested in cylinder liner or block cavitation ("pitting", "erosion", "electrolysis").

Any premium for overtime labor requested by the purchaser.

Costs of transporting the engine or the equipment in which it is installed to and from the location at which the warranty service is performed, if such costs are in excess of the maximum amount payable to the service location were the warranty service performed at the engine's location.

Costs incurred in gaining access to the engine; i.e., overcoming physical barriers such as walls, fences, floors, decks or similar structures impeding access to the engine, rental of cranes or similar, or construction of ramps or lifts or protective structures for engine removal and reinstallation.

Incidental travel costs including tolls, meals, lodging, and similar.

Service outlet costs incurred in solving or attempting to solve non-warrantable problems.

Services performed by a party other than an authorized John Deere engine service dealer, unless required by law.

Charges by dealers for initial engine start-up and inspection, deemed unnecessary by John Deere when operation and maintenance instructions supplied with the engine are followed.

Costs of interpreting or translating services.

No Representations or Implied Warranty

Where permitted by law, neither John Deere nor any company affiliated with it makes any guaranties, warranties, conditions, representations or promises, express or implied, oral or written, as to the nonoccurrence of any defect or the quality or performance of its engines other than those set forth herein, and DOES NOT MAKE ANY IMPLIED WARRANTY OR CONDITIONS OF MERCHANTABILITY OR FITNESS otherwise provided for in the Uniform Commercial Code or required by any Sale of Goods Act or any other statute. This exclusion includes fundamental terms. In no event will a John Deere engine distributor or engine service dealer, John Deere equipment dealer, or John Deere or any company affiliated with John Deere be liable for incidental or consequential damages or injuries including, but not limited to, loss of profits, loss of crops, rental of substitute equipment or other commercial loss, damage to the equipment in which the engine is installed or for damage suffered by purchaser as a result of fundamental breaches of contract or breach of fundamental terms, unless such damages or injuries are caused by the gross negligence or intentional acts of the foregoing parties.

Remedy Limitation

The remedies set forth in this warranty are the purchaser's exclusive remedies in connection with the performance of, or any breach of guaranty, condition, or warranty in respect of new John Deere engines. In the event the above warranty fails to correct purchaser's performance problems caused by defects in workmanship and/or materials, purchaser's exclusive remedy shall be limited to payment by John Deere of actual damages in an amount not to exceed the cost of the engine.

No Seller's Warranty

No person or entity, other than John Deere, who sells the engine or product in which the engine has been installed makes any guaranty or warranty of its own on any engine warranted by John Deere unless it delivers to the purchaser a separate written guaranty certificate specifically guaranteeing the engine, in which case John Deere shall have no obligation to the purchaser. Neither original equipment manufacturers, engine or equipment distributors, engine or equipment dealers, nor any other person or entity, has any authority to make any representation or promise on behalf of John Deere or to modify the terms or limitations of this warranty in any way.

Additional Information

For additional information concerning the John Deere New Off-Highway Engine Warranty, see booklet *Engine Owner's Warranty – Worldwide*.



YANMAR INDUSTRIAL DIESEL ENGINE LIMITED WARRANTY

WHO GIVES AND WHO RECEIVES THIS WARRANTY

YANMAR DIESEL ENGINE CO., LTD. ("YANMAR") warrants to the original retail purchaser only that each new YANMAR distributor, dealer, or other manufacturer (OEM, and their distributors and dealers) shall be free from defects in materials and workmanship under normal use and service during the Warranty Period set forth below.

This warranty gives you specific legal rights, and you may also have other rights which vary by country or from state to state.

WARRANTY PERIOD

The Warranty Period begins on the date of delivery to the original retail purchaser. The date of delivery and all other relevant information must be recorded on a Delivery Report.

The following table lists the warranted duration or total operation hours, whichever comes first, for each YANMAR industrial diesel engine and associated product.

<u>ITEM</u>	<u>RENTAL USE</u>	<u>PERSONAL USE</u>
Industrial diesel engines and/or Associated products	24 months/2,000 hours	24 months/2,000 hours

NOTE: Electric parts, such as starter motor, alternator, dynamo or turbochargers are covered for the first 12 months or 1000 hours, whichever occurs first.

The above warranties (by duration or operation hours) begin on the date of delivery recorded on the Delivery Report and are valid only for the original retail purchaser.

YANMAR shall honor a claim filed during the Warranty Period, duration of operation hours, whichever comes first; provided however, that operation hours shall apply only to YANMAR products equipped with an hour meter.

YANMAR HEREBY DISCLAIMS ALL IMPLIED WARRANTIES AFTER THE APPLICABLE EXPIRATION DATE OF THE EXPRESS LIMITED WARRANTY. Some states or countries do not allow limitations on how long an implied warranty lasts, so the above limitation may not apply to you.

WHAT IS COVERED BY THIS WARRANTY

YANMAR will replace or repair, at its option, without charge for the parts or labor, at a place designed by YANMAR, any parts of a YANMAR engine/product covered by this Warranty found to be defective in material or workmanship.

WHAT IS NOT COVERED BY THIS WARRANTY

This Warranty does not cover parts affected, damaged or depreciated by misuse, abuse, improper maintenance, neglect, use of unsuitable attachments or non-genuine parts, ordinary wear, rust or corrosion, inadequate transportation, accident, or service by an unauthorized facility.

Expendable parts, such as all kinds of filters, belts, gaskets, rubber hoses, fuses, brushes, etc., and lubricants are excluded from this Warranty.

This Warranty does not obligate YANMAR to bear any fees for transportation of any YANMAR engine/product to and from the place designated by YANMAR for Warranty Service.

YANMAR MAKES NO OTHER EXPRESS WARRANTIES OTHER THAN SET FORTH ABOVE, AND ALL OTHER OBLIGATIONS OR LIABILITIES, INCLUDING SPECIAL OR CONSEQUENTIAL DAMAGES OR CONTINGENT LIABILITIES ARISING OUT OF THE FAILURE OF ANY YANMAR ENGINE/PRODUCT TO OPERATE PROPERLY, ARE HEREBY EXCLUDED.

No person is authorized to give any other Warranty or to assume any additional obligation on YANMAR's behalf.

Some states or countries do not allow the exclusion or limitation of incidental or consequential or special damages, so the above limitation or exclusion may not apply to you.

PROCEDURE FOR MAKING A WARRANTY CLAIM

For any defect covered by this Warranty, contact any authorized YANMAR distributor or dealer to obtain the name, address, and telephone number of the nearest authorized Service and Repair Facility within thirty (30) days after discovery of such defect.

The YANMAR Warranty shall apply to YANMAR engines/products operated in any state or country regardless of the state or province in which the YANMAR engine/product was purchased, provided, however, that the YANMAR Warranty Handbook shall be presented and that Warranty service is provided by the YANMAR Service Network.

CD80M Dri-Prime® Pumps

CD80M

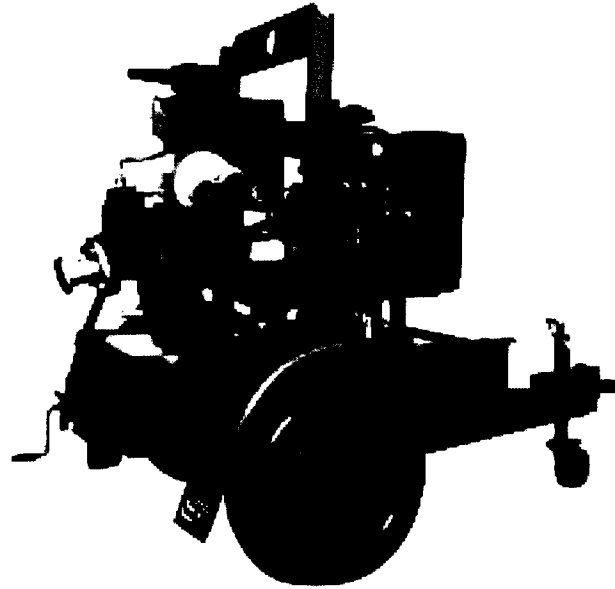

The Godwin Dri-Prime 3" (75mm) CD80M automatic priming centrifugal pump is a compact and highly maneuverable portable pumping system that can deliver a maximum of 450 gallons per minute (28.4 l/se.c) and total dynamic heads to 93 feet (28.3M). The CD80M comes standard mounted on a highway trailer or skid mounted, and both include an integral 30 gallon (113.5 liter) fuel tank for overnight running capabilities. A recessed impeller model is also available for increased solids handling. Indefinite dry running is no problem due to the unique Godwin oil bath mechanical seal design. Solids handling, dry-running and portability make the CD80M the perfect choice for small dewatering and bypass applications.

Features

- Close coupled centrifugal pump with vacuum priming compressor mounted to a diesel engine. Also available in electric drive or as bare shaft pumpend.
- All cast iron construction with cast chromium steel impeller. Also available in 316 stainless steel.
- Extensive application flexibility — will handle raw sewage, sludges and liquids with solids up to 1-5/8" (40mm) in diameter.
- Continuously operated "Godwin" air ejector priming device requiring no form of periodic adjustment or control.
- Dry running, oil bath, mechanical seal with abrasion resistant solid silicon carbide interfaces.
- Solids handling mushroom-type Non-Return Valve with renewable flexible rubber seat and quick release access feature.
- Compact unit mounted on two-wheeled highway trailer or skid base, both incorporating integral overnight running fuel tank.
- Simple maintenance — normally limited to checking engine and seal cavity oil levels.
- Standard engine: Yanmar 3TNV76. Available with a variety of engines including Lister, Hatz, Perkins and Deutz.
- Available with optional silence pack.

godwin
pumps



CD80M Performance Curve

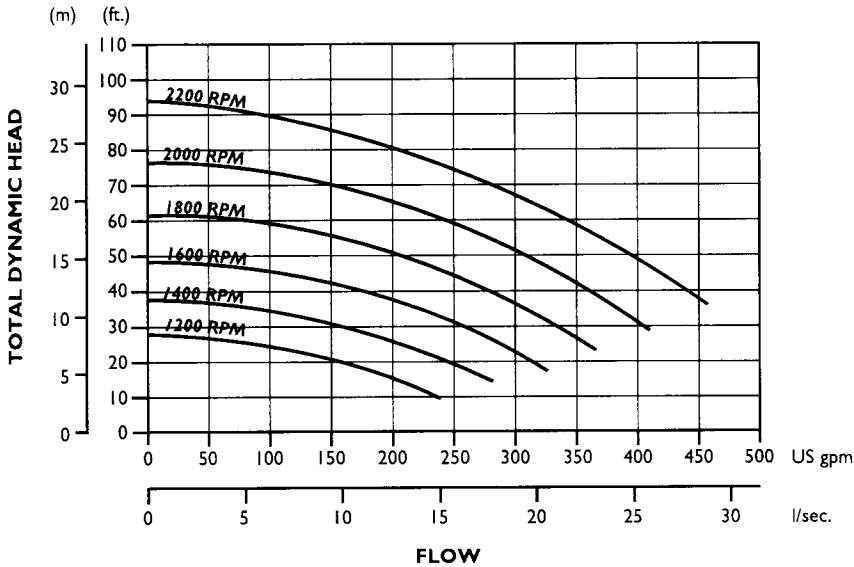

Performance Table

Diesel Set — Yanmar 3TNE74 14.0 hp (11 kw) @ 2200 rpm
 Impeller Diameter — 7 1/2 inches (190 mm)

Total Suction Head — Feet	Total Delivery Head — Feet				
	10	15	20	25	30
10	450	435	430	415	400
15	440	430	425	410	385
20	410	385	350	315	290
25	370	330	300	280	255

Performance data listed in table and curves based on water tests at sea level and 68° F (20° C). Larger diameter pipes may be required for maximum flows.

Dimensions

CD80M — Yanmar 3TNE76, GP30 Highway Trailer
 Weight: 1,550 lbs. (703 kg.)

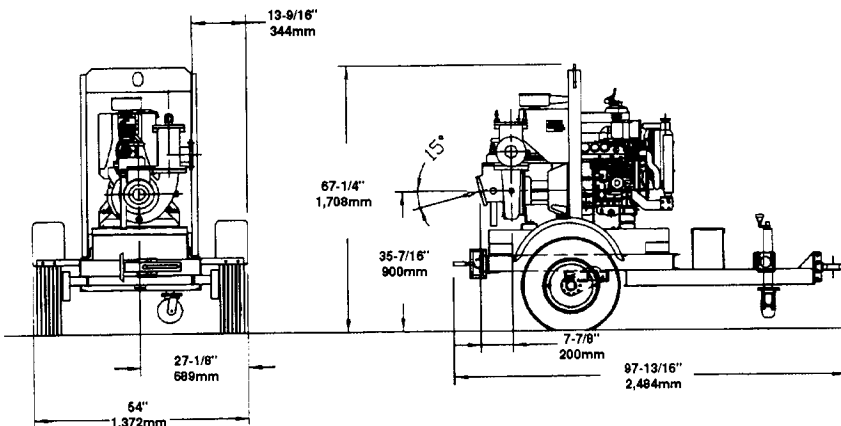

Specifications

- Maximum Operating Speed:**
2200 rpm
- Maximum Operating Temperature:**
+212° F (100° C)
- Maximum Working Pressure:**
41 psi (2.8 BAR)
- Maximum Suction Pressure:**
29.0 psi (2.0 BAR)
- Maximum Casing Pressure:**
61 psi (4.2 BAR)
- Fuel Tank Capacity:**
30 gallons (113.5 liters)
- Fuel Consumption:**
0.84 gph (3.18 lph)
- Pipe Connections:**
3" (75mm) ASA 150#
- Solids Handling:**
1-5/8" (40mm) diameter

Materials

- Pump Casing, Suction Cover, Separation Tank and Wearplates:**
Close-grained cast iron
- Impeller:**
Cast chromium steel to minimum Brinell hardness, 341 HB
- Shaft:**
1-1/2% nickel/chromium steel
- NRV-Mushroom:**
High nitrile rubber
- Mechanical Seal Faces:**
Solid silicon carbide

godwin
pumps

One Floodgate Road, Bridgeport, NJ 08014, USA
 (856) 467-3636 • Fax: (856) 467-4841
 Quenington, Cirencester, Glos., GL7 5BX, UK
 +44 (0)1285 750271 • Fax: +44 (0)1285 750352

E-mail: sales@godwinpumps.com
 www.godwinpumps.com

BRANCH LOCATIONS:
 Connecticut • Pennsylvania • New York • Ohio
 Illinois • Maryland • Virginia • West Virginia
 Georgia • South Carolina • North Carolina
 Florida • Texas • Montana • California • Washington

Dri-Prime® and the color orange for pumps are registered trademarks of Godwin Pumps of America, Inc.
 Specifications and illustrations are subject to revision without notice.
 © Copyright 2003-2006 Godwin Pumps of America, Inc.
 All rights reserved.

CD103M Dri-Prime Pump

CD103M

The Godwin Dri-Prime CD103M pump offers flow rates to 1,022 USGPM and discharge heads to 169' (51m). Also it has the capability of handling solids up to 3" (75mm) in diameter.

The CD103M is able to prime to 28' (8.5 m) of suction lift from dry.

Indefinite dry-running is no problem due to the unique Godwin oil bath mechanical seal design. Solids handling, dry-running and portability make the CD103M the perfect choice for small dewatering and bypass applications. The standard model is mounted on a highway trailer, with a skid-mounted option.

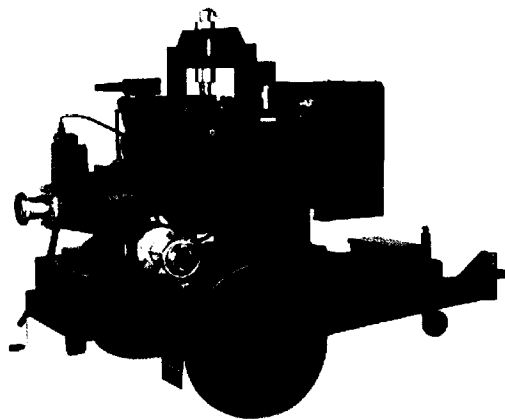

Features

- Simple maintenance normally limited to checking fluid levels.
- Close coupled centrifugal pump with vacuum priming compressor mounted to a diesel engine. Also available in electric drive or as bare shaft pumpend.
- Extensive application flexibility. It will handle sewage, slurries and liquids with solids up to 3" in diameter.
- Continuously operated Godwin venturi air ejector priming device requiring no form of periodic adjustment or control.
- Dry-running heavy duty mechanical seal with abrasion-resistant interfaces.
- Also available in a Critically Silenced unit which drastically reduce noise levels of the pump.
- Standard engine John Deere 4024TF281. Also available with Caterpillar C2.2T.
- The volute & suction cover are made from cast iron bs1452:1990 grade 220 and the impeller is made from cast steel bs3100 a5 hardness to 200 hb brinell.

Specifications

Suction connection	4" 125# ANSI B16.1
Delivery connection	4" 125# ANSI B16.1
Max capacity	1022 USGPM
Max head	169' (51m)
Max solids handling	3" (75mm)
Max impeller diameter	10" (256mm)
Max operating temp	176°F (80°C)
Max working pressure	79.8 psi (5.5 bar)
Max suction pressure	58.0 psi (4.0 bar)
Max casing pressure	119.7 psi (8.3 bar)
Max operating speed	2200 rpm

godwin 
a xylem brand

Reference number : 95-1008-3000
Date of issue : August 25, 2011
Issue : 1

Please contact Godwin for further details.
A typical picture of the pump is shown.
All information is approximate and for general guidance only.

Performance Curve

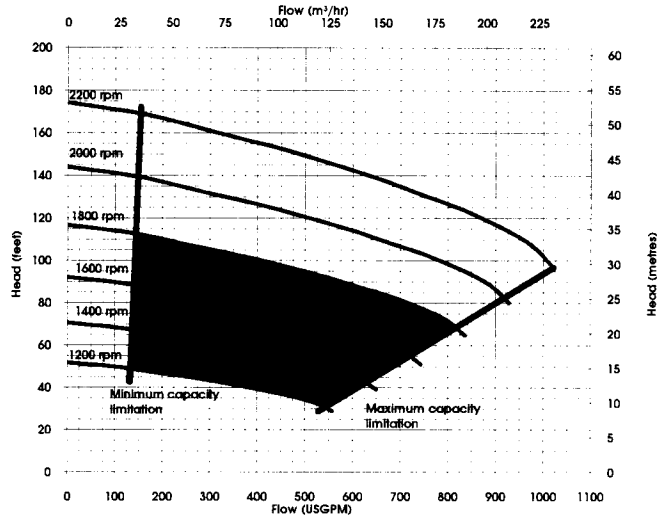

Materials

Pump casing & suction cover	Cast iron BS1452:1990 grade 220
Wearplates	Cast iron to BS1452 Gr220
Pump shaft	Carbon steel BS970-3:1991 080M40
Impeller	Cast steel BS3100 A5 hardness to 200 HB Brinell
Non-return valve body	Cast iron BS1452 grade 220
Mechanical seal faces	Silicon carbide vs silicon carbide

Engine option 1

John Deere, 4024TF281, 35.5 HP @ 1800 rpm
 Impeller diameter 10" (256 mm)

Engine option 2

Caterpillar, C2.2T, 38.5 HP @ 1800 rpm
 Impeller diameter 10" (256 mm)

Suction Lift Table

Total Suction Head (')	Total Delivery Head (')				
	49	66	82	98	115
	Output (USGPM)				
9.8	837	748	528	286	-
15.1	815	682	440	176	-
20.0	726	616	352	-	-
24.9	660	528	220	-	-

Suction Lift Table

Total Suction Head (')	Total Delivery Head (')				
	49	66	82	98	115
	Output (USGPM)				
9.8	837	748	528	286	-
15.1	815	682	440	176	-
20.0	726	616	352	-	-
24.9	660	528	220	-	-

Fuel capacity (Full) 60 US Gal, (Usable) 60 US Gal
 Fuel consumption @ 1800 rpm BEP 1.6 US Gal/hr
 Weight: (Dry) 2,377 lbs, (Wet) 2,864 lbs
 Dimensions: (L) 118" x (W) 66" x (H) 72"

Fuel capacity (Full) 60 US Gal, (Usable) 60 US Gal
 Fuel consumption @ 1800 rpm BEP 1.7 US Gal/hr
 Weight: (Dry) 2,326 lbs, (Wet) 2,812 lbs
 Dimensions: (L) 118" x (W) 66" x (H) 72"

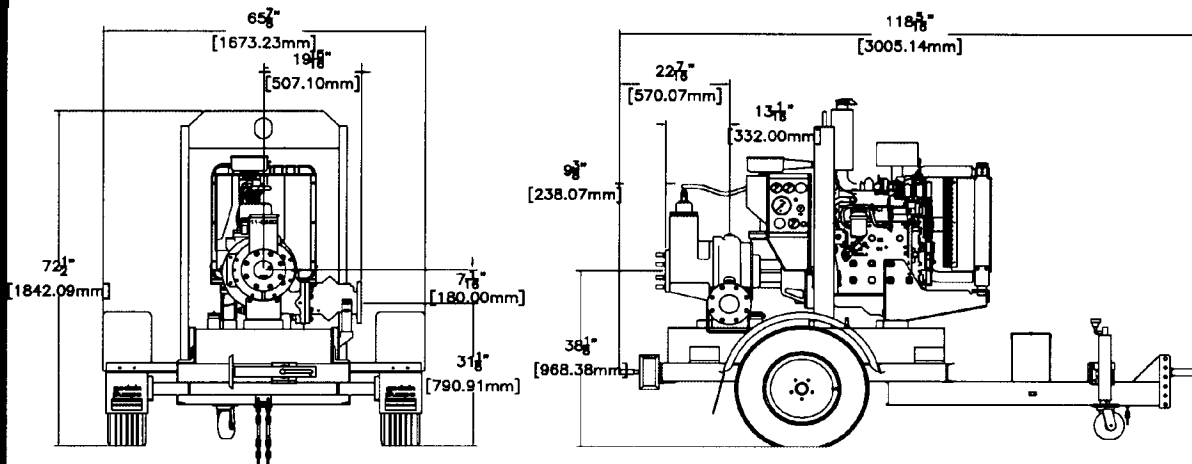

Performance data provided in tables is based on water tests at sea level and 68°F ambient.
 All information is approximate and for general guidance only.
 Please contact Godwin Pumps for further details.
 Reference number : 95-1008-3000
 Date of issue : August 25, 2011
 Issue : 1



84 Floodgate Road | Bridgeport, NJ 08014 USA
 P: (856) 467-3636 | F: (856) 467-4841
 Sales@godwinpumps.com | godwinpumps.com



CERTIFICATE OF LIABILITY INSURANCE

DATE (MM/DD/YYYY)
05/29/2013

THIS CERTIFICATE IS ISSUED AS A MATTER OF INFORMATION ONLY AND CONFERS NO RIGHTS UPON THE CERTIFICATE HOLDER. THIS CERTIFICATE DOES NOT AFFIRMATIVELY OR NEGATIVELY AMEND, EXTEND OR ALTER THE COVERAGE AFFORDED BY THE POLICIES BELOW. THIS CERTIFICATE OF INSURANCE DOES NOT CONSTITUTE A CONTRACT BETWEEN THE ISSUING INSURER(S), AUTHORIZED REPRESENTATIVE OR PRODUCER, AND THE CERTIFICATE HOLDER.

IMPORTANT: If the certificate holder is an ADDITIONAL INSURED, the policy(ies) must be endorsed. If SUBROGATION IS WAIVED, subject to the terms and conditions of the policy, certain policies may require an endorsement. A statement on this certificate does not confer rights to the certificate holder in lieu of such endorsement(s).

PRODUCER Marsh USA, Inc. 1166 Avenue of the Americas New York, NY 10036 Attn: NewYork.certs@Marsh.com Fax: 212-948-0500 506636--XS-12-13 INSURED Xylem Dewatering Solutions, Inc. d/b/a Godwin Pumps of America. a wholly owned subsidiary of Xylem Inc. 84 Floodgate Road Bridgeport, NJ 08014	CONTACT NAME: PHONE (A/C, No, Ext): E-MAIL ADDRESS: FAX (A/C, No):
	INSURER(S) AFFORDING COVERAGE INSURER A: Allianz Global Risks US Insurance Co INSURER B: INSURER C: INSURER D: INSURER E: INSURER F:

COVERAGES **CERTIFICATE NUMBER:** NYC-006642216-01 **REVISION NUMBER:** 1

THIS IS TO CERTIFY THAT THE POLICIES OF INSURANCE LISTED BELOW HAVE BEEN ISSUED TO THE INSURED NAMED ABOVE FOR THE POLICY PERIOD INDICATED. NOTWITHSTANDING ANY REQUIREMENT, TERM OR CONDITION OF ANY CONTRACT OR OTHER DOCUMENT WITH RESPECT TO WHICH THIS CERTIFICATE MAY BE ISSUED OR MAY PERTAIN, THE INSURANCE AFFORDED BY THE POLICIES DESCRIBED HEREIN IS SUBJECT TO ALL THE TERMS, EXCLUSIONS AND CONDITIONS OF SUCH POLICIES. LIMITS SHOWN MAY HAVE BEEN REDUCED BY PAID CLAIMS.

INSR LTR	TYPE OF INSURANCE	ADDL SUBR INSR WVD	POLICY NUMBER	POLICY EFF (MM/DD/YYYY)	POLICY EXP (MM/DD/YYYY)	LIMITS
	GENERAL LIABILITY					EACH OCCURRENCE \$ DAMAGE TO RENTED PREMISES (Ea occurrence) \$ MED EXP (Any one person) \$ PERSONAL & ADV INJURY \$ GENERAL AGGREGATE \$ PRODUCTS - COMP/OP AGG \$
	COMMERCIAL GENERAL LIABILITY CLAIMS-MADE OCCUR					
	GEN'L AGGREGATE LIMIT APPLIES PER: POLICY PROJECT LOC					
	AUTOMOBILE LIABILITY					COMBINED SINGLE LIMIT (Ea accident) \$ BODILY INJURY (Per person) \$ BODILY INJURY (Per accident) \$ PROPERTY DAMAGE (Per accident) \$
	ANY AUTO ALL OWNED AUTOS HIRED AUTOS	SCHEDULED AUTOS NON-OWNED AUTOS				
A X	UMBRELLA LIAB EXCESS LIAB DED RETENTION \$	X OCCUR CLAIMS-MADE	ULA 2003984	10/31/2012	10/31/2013	EACH OCCURRENCE \$ 2,000,000 AGGREGATE \$ 2,000,000
	WORKERS COMPENSATION AND EMPLOYERS' LIABILITY	Y/N N N/A				WC STATUTORY LIMITS OTHER E.L. EACH ACCIDENT \$ E.L. DISEASE - EA EMPLOYEE \$ E.L. DISEASE - POLICY LIMIT \$
	ANY PROPRIETOR/PARTNER/EXECUTIVE OFFICER/MEMBER EXCLUDED? (Mandatory in NH) If yes, describe under DESCRIPTION OF OPERATIONS below					

DESCRIPTION OF OPERATIONS / LOCATIONS / VEHICLES (Attach ACORD 101, Additional Remarks Schedule, if more space is required)
LEXINGTON FAYETTE URBAN COUNTY GOVERNMENT IS INCLUDED AS ADDITIONAL INSURED AS REQUIRED BY WRITTEN CONTRACT BUT ONLY AS RESPECTS EXCESS LIABILITY OF THE NAMED INSURED. WAIVER OF SUBROGATION IS APPLICABLE WHERE REQUIRED BY WRITTEN CONTRACT.

CERTIFICATE HOLDER CANCELLATION

LEXINGTON FAYETTE URBAN COUNTY GOVERNMENT 200 EAST MAIN STREET LEXINGTON, KY 40507	SHOULD ANY OF THE ABOVE DESCRIBED POLICIES BE CANCELLED BEFORE THE EXPIRATION DATE THEREOF, NOTICE WILL BE DELIVERED IN ACCORDANCE WITH THE POLICY PROVISIONS. AUTHORIZED REPRESENTATIVE of Marsh USA Inc. Ryan O'Connor
--	---