



LEXINGTON

Lexington-Fayette Urban County Government

Lexington, Kentucky
Horse Capital of the World

Division of Central Purchasing

Date of Issue: December 2, 2021

INVITATION TO BID #125-2021 Frontloader

Bid Opening Date: December 16, 2021 **Bid Opening Time:** 2:00 PM
Address: 200 East Main Street, 3rd Floor, Room 338, Lexington, Kentucky 40507
Type of Bid: Price Contract

Pre Bid Meeting: N/A **Pre Bid Time:** N/A
Address: N/A

Sealed bids will be received via Ion Wave, until **2:00 PM**, prevailing local time on **12/16/2021**. Bids must be received by the above-mentioned date and time. Bids should be submitted via:

Ion Wave
<https://lexingtonky.ionwave.net>

The Lexington-Fayette Urban County Government assumes no responsibility for bids that are not delivered as indicated above. All bids must be signed. Bids are to include all shipping, handling and associated fees to the point of delivery located at: Lexington, KY

<input type="checkbox"/> Bid Specifications Met <input checked="" type="checkbox"/> Check One: Exceptions to Bid Specifications. <i>Exceptions shall be itemized and attached to bid proposal submitted.</i>	Proposed Delivery: Based on days after acceptance of bid. 200-250 Days est. <i>P.O. being issued.</i>
Procurement Card Usage —The Lexington-Fayette Urban County Government may be using Procurement Cards to purchase goods and services and also to make payments. Will you accept Procurement Cards? <input type="checkbox"/> Yes <input checked="" type="checkbox"/> No	

Submitted by: Worldwide Equipment
Firm Name

945 Nandino Blvd.

Lexington Ky 40511
Address
City, State & Zip

Bid must be signed: [Signature] G.M.
(original signature) *Signature of Authorized Company Representative – Title*

Jim Dotson
Representative's Name (Typed or printed)

559-281-5152 78000
Area Code - Phone - Extension Fax #

jimdotson@thetruckpeople.com.
E-Mail Address

The Affidavit in this bid must be completed before your firm can be considered for award of this contract.

PRICE SHEET

Price for 1 complete unit:

Chassis Make and Model Mack LR Packer Body Make and Model EZ-Pack Hercules
Chassis with 9 Liter CNG \$ 161,628.⁶⁰ Packer Body \$ 179,186.⁰⁰ Total \$ 340,814.⁶⁰
Chassis with 12 Liter CNG \$ _____ Packer Body \$ _____ Total \$ _____

Price for 2 or more units:

Chassis Make and Model Mack LR Packer Body Make and Model EZ Pack Hercules
Chassis with 9 Liter CNG \$ 161,628.⁶⁰ Packer Body \$ 179,186.⁰⁰ Total \$ 340,814.⁶⁰
Chassis with 12 Liter CNG \$ _____ Packer Body \$ _____ Total \$ _____

AFFIDAVIT

Comes the Affiant, Worldwide Equipment and after being first duly sworn under penalty of perjury as follows:

1. His/her name is Jim Dotson and he/she is the individual submitting the bid or is the authorized representative of Worldwide Equipment the entity submitting the bid (hereinafter referred to as "Bidder")
2. Bidder will pay all taxes and fees, which are owed to the Lexington-Fayette Urban County Government at the time the bid is submitted, prior to award of the contract and will maintain a "current" status in regard to those taxes and fees during the life of the contract.
3. Bidder will obtain a Lexington-Fayette Urban County Government business license, if applicable, prior to award of the contract.
4. Bidder has authorized the Division of Central Purchasing to verify the above-mentioned information with the Division of Revenue and to disclose to the Urban County Council that taxes and/or fees are delinquent or that a business license has not been obtained.
5. Bidder has not knowingly violated any provision of the campaign finance laws of the Commonwealth of Kentucky within the past five (5) years and the award of a contract to the Bidder will not violate any provision of the campaign finance laws of the Commonwealth.
6. Bidder has not knowingly violated any provision of Chapter 25 of the Lexington-Fayette Urban County Government Code of Ordinances, known as "Ethics Act."
7. Bidder acknowledges that "knowingly" for purposes of this Affidavit means, with respect to conduct or to circumstances described by a statute or ordinance defining an offense, that a person is aware or should have been aware that his conduct is of that nature or that the circumstance exists.

Further, Affiant sayeth naught. Jim Dotson

STATE OF Kentucky

COUNTY OF Fayette

The foregoing instrument was subscribed, sworn to and acknowledged before me by Jim Dotson on this the 12th day of Dec, 2024.

My Commission expires: 4/26/25

Stephen Carthel Smith
NOTARY PUBLIC, STATE AT LARGE

Please refer to Section II. Bid Conditions, Item "U" prior to completing this form.

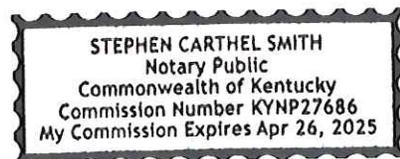

I. GREEN PROCUREMENT

A. ENERGY

The Lexington-Fayette Urban County Government is committed to protecting our environment and being fiscally responsible to our citizens.

The Lexington-Fayette Urban County Government mandates the use of Energy Star compliant products if they are available in the marketplace (go to www.Energystar.gov). If these products are available, but not submitted in your pricing, your bid will be rejected as non-compliant.

ENERGY STAR is a government program that offers businesses and consumers energy-efficient solutions, making it easy to save money while protecting the environment for future generations.

Key Benefits

These products use 25 to 50% less energy
Reduced energy costs without compromising quality or performance
Reduced air pollution because fewer fossil fuels are burned
Significant return on investment
Extended product life and decreased maintenance

B. GREEN SEAL CERTIFIED PRODUCTS

The Lexington-Fayette Urban County Government is also committed to using other environmentally friendly products that do not negatively impact our environment. Green Seal is a non-profit organization devoted to environmental standard setting, product certification, and public education.

Go to www.Greenseal.org to find available certified products. These products will have a reduced impact on the environment and on human health. The products to be used must be pre-approved by the LFUCG prior to commencement of any work in any LFUCG facility. If a Green Seal product is not available, the LFUCG must provide a signed waiver to use an alternate product. Please provide information on the Green Seal products being used with your bid response.

C. GREEN COMMUNITY

The Lexington-Fayette Urban County Government (LFUCG) serves as a principal, along with the University of Kentucky and Fayette County Public Schools, in the Bluegrass Partnership for a Green Community. The Purchasing Team component of the Partnership collaborates on economy of scale purchasing that promotes and enhances environmental initiatives. Specifically, when applicable, each principal is interested in obtaining best value products and/or services which promote environment initiatives via solicitations and awards from the other principals.

If your company is the successful bidder on this Invitation For Bid, do you agree to extend the same product/service pricing to the other principals of the Bluegrass Partnership for a Green Community (i.e. University of Kentucky and Fayette County Schools) if requested?

Yes No

II. Bid Conditions

- A. No bid may be withdrawn for a period of sixty (60) days after the date and time set for opening.
- B. No bid may be altered after the date and time set for opening. In the case of obvious errors, the Division of Central Purchasing may permit the withdrawal of a bid. The decision as to whether a bid may be withdrawn shall be that of the Division of Central Purchasing.
- C. Acceptance of this proposal shall be enactment of an Ordinance by the Urban County Council.
- D. The bidder agrees that the Urban County Government reserves the right to reject any and all bids for either fiscal or technical reasons, and to award each part of the bid separately, all parts to one vendor or all parts to multiple vendors.
- E. Minor exceptions may not eliminate the bidder. The decision as to whether any exception is minor shall be entirely that of the head of the requisitioning Department or Division and the Director of the Division of Central Purchasing. The Urban County Government may waive technicalities and informalities where such waiver would best serve the interests of the Urban County Government.
- F. Manufacturer's catalogue numbers, trade names, etc., where shown herein are for descriptive purposes and are to guide the bidder in interpreting the standard of quality, design, and performance desired, and shall not be construed to exclude proposals based on furnishing other types of materials and/or services. However, any substitution or departure proposed by the bidder must be clearly noted and described; otherwise, it will be assumed that the bidder intends to supply items specifically mentioned in this Invitation for Bids.
- G. The Urban County Government may require demonstrations of the materials proposed herein prior to acceptance of this proposal.
- H. Bids must be submitted on this form and must be signed by the bidder or his authorized representative. Unsigned bids will not be considered.
- I. Bids must be submitted prior to the date and time indicated for opening. Bids submitted after this time will not be considered.
- J. Bids that are not submitted via Ion Wave will be rejected.
- K. Bidder is requested to show both unit prices and lot prices. In the event of error, the unit price shall prevail.
- L. A certified check or Bid Bond in the amount of XX percent of the bid price must be attached hereto. This check must be made payable to the Lexington-Fayette Urban County Government, and will be returned when the material and/or services specified herein have been delivered in accordance with specifications. In the event of failure to perform within the time period set forth in this bid, it is agreed the certified check may be cashed and the funds retained by the Lexington-Fayette Urban County Government as liquidated damages. Checks of unsuccessful bidders will be returned when the bid has been awarded.
- M. The delivery dates specified by bidder may be a factor in the determination of the successful bidder.
- N. Tabulations of bids received may be mailed to bidders. Bidders requesting tabulations must enclose a stamped, self-addressed envelope with the bid.
- O. The Lexington-Fayette Urban County Government is exempt from Kentucky Sales Tax and Federal Excise Tax on materials purchased from this bid invitation. Materials purchased by the bidder for construction projects are not tax exempt and are the sole responsibility of the bidder.
- P. All material furnished hereunder must be in full compliance with OSHA regulations.
- Q. If more than one bid is offered by one party, or by any person or persons representing a party, all such bids shall be rejected.
- R. Signature on the face of this bid by the Bidder or his authorized representative shall be construed as acceptance of and compliance with all terms and conditions contained herein.
- S. The Entity (regardless of whether construction contractor, non-construction contractor or supplier) agrees to

provide equal opportunity in employment for all qualified persons, to prohibit discrimination in employment because of race, color, religion, sex (including pregnancy, sexual orientation or gender identity), national origin, disability, age, genetic information, political affiliation, or veteran status, and to promote equal employment through a positive, continuing program from itself and each of its sub-contracting agents. This program of equal employment opportunity shall apply to every aspect of its employment policies and practices.

- T. The Kentucky Equal Employment Opportunity Act of 1978 (KRS 45.560-45.640) requires that any county, city, town, school district, water district, hospital district, or other political subdivision of the state shall include in directly or indirectly publicly funded contracts for supplies, materials, services, or equipment hereinafter entered into the following provisions:

During the performance of this contract, the contractor agrees as follows:

- (1) The contractor will not discriminate against any employee or applicant for employment because of race, color, religion, sex, age or national origin;*
- (2) The contractor will state in all solicitations or advertisements for employees placed by or on behalf of the contractors that all qualified applicants will receive consideration for employment without regard to race, color, religion, sex, age or national origin;*
- (3) The contractor will post notices in conspicuous places, available to employees and applicants for employment, setting forth the provisions of the non-discrimination clauses required by this section; and*
- (4) The contractor will send a notice to each labor union or representative of workers with which he has a collective bargaining agreement or other contract or understanding advising the labor union or workers' representative of the contractor's commitments under the nondiscrimination clauses.*

The Act further provides:

KRS 45.610. Hiring minorities - Information required

- (1) For the length of the contract, each contractor shall hire minorities from other sources within the drawing area, should the union with which he has collective bargaining agreements be unwilling to supply sufficient minorities to satisfy the agreed upon goals and timetable.*
- (2) Each contractor shall, for the length of the contract, furnish such information as required by KRS 45.560 to KRS 45.640 and by such rules, regulations and orders issued pursuant thereto and will permit access to all books and records pertaining to his employment practices and work sites by the contracting agency and the department for purposes of investigation to ascertain compliance with KRS 45.560 to 45.640 and such rules, regulations and orders issued pursuant thereto.*

KRS 45.620. Action against contractor - Hiring of minority contractor or subcontractor

- (1) If any contractor is found by the department to have engaged in an unlawful practice under this chapter during the course of performing under a contract or subcontract covered under KRS 45.560 to 45.640, the department shall so certify to the contracting agency and such certification shall be binding upon the contracting agency unless it is reversed in the course of judicial review.*
- (2) If the contractor is found to have committed an unlawful practice under KRS 45.560 to 45.640, the contracting agency may cancel or terminate the contract, conditioned upon a program for future compliance approved by the contracting agency and the department. The contracting agency may declare such a contractor ineligible to bid on further contracts with that agency until such time as the contractor complies in full with the requirements of KRS 45.560 to 45.640.*
- (3) The equal employment provisions of KRS 45.560 to 45.640 may be met in part by a contractor by subcontracting to a minority contractor or subcontractor. For the provisions of KRS 45.560 to 45.640, a minority contractor or subcontractor shall mean a business that is owned and controlled by one or more persons disadvantaged by racial or ethnic circumstances.*

KRS 45.630 Termination of existing employee not required, when

Any provision of KRS 45.560 to 45.640 notwithstanding, no contractor shall be required to terminate an existing employee upon proof that that employee was employed prior to the date of the contract.

KRS 45.640 Minimum skills

Nothing in KRS 45.560 to 45.640 shall require a contractor to hire anyone who fails to demonstrate the minimum skills required to perform a particular job.

It is recommended that all of the provisions above quoted to be included as special conditions in each contract. In the case of a contract exceeding \$250,000, the contractor is required to furnish evidence that his work-force in Kentucky is representative of the available work-force in the area from which he draws employees, or to supply an Affirmative Action plan which will achieve such representation during the life of the contract.

- U. Any party, firm or individual submitting a proposal pursuant to this invitation must be in compliance with the requirements of the Lexington-Fayette Urban County Government regarding taxes and fees before they can be considered for award of this invitation and must maintain a "current" status with regard to those taxes and fees throughout the term of the contract. The contractor must be in compliance with Chapter 13 from the Code of Ordinances of the Lexington-Fayette Urban County Government. The contractor must be in compliance with Ordinance 35-2000 pursuant to contractor registration with the Division of Building Inspection. If applicable, said business must have a Fayette County business license.

Pursuant to KRS 45A.343 and KRS 45A.345, the contractor shall

- (1) *Reveal any final determination of a violation by the contractor within the previous five year period pursuant to KRS Chapters 136 (corporation and utility taxes), 139 (sales and use taxes), 141 (income taxes), 337 (wages and hours), 338 (occupational safety and health of employees), 341 (unemployment and compensation) and 342 (labor and human rights) that apply to the contractor; and*
- (2) *Be in continuous compliance with the above-mentioned KRS provisions that apply to the contractor for the duration of the contract.*

A contractor's failure to reveal the above or to comply with such provisions for the duration of the contract shall be grounds for cancellation of the contract and disqualification of the contractor from eligibility for future contracts for a period of two (2) years.

- V. Vendors who respond to this invitation have the right to file a notice of contention associated with the bid process or to file a notice of appeal of the recommendation made by the Director of Central Purchasing resulting from this invitation.

Notice of contention with the bid process must be filed within 3 business days of the bid/proposal opening by (1) sending a written notice, including sufficient documentation to support contention, to the Director of the Division of Central Purchasing or (2) submitting a written request for a meeting with the Director of Central Purchasing to explain his/her contention with the bid process. After consulting with the Commissioner of Finance the Chief Administrative Officer and reviewing the documentation and/or hearing the vendor, the Director of Central Purchasing shall promptly respond in writing findings as to the compliance with bid processes. If, based on this review, a bid process irregularity is deemed to have occurred the Director of Central Purchasing will consult with the Commissioner of Finance, the Chief Administrative Officer and the Department of Law as to the appropriate remedy. Notice of appeal of a bid recommendation must be filed within 3 business days of the bid recommendation by (1) sending a written notice, including sufficient documentation to support appeal, to the Director, Division of Central Purchasing or (2) submitting a written request for a meeting with the Director of Central Purchasing to explain his appeal. After reviewing the documentation and/or hearing the vendor and consulting with the Commissioner of Finance and the Chief Administrative Officer, the Director of Central Purchasing shall in writing, affirm or withdraw the recommendation.

III. Procurement Contract Bid Conditions

- A. The terms of this agreement shall be for 1 year(s) from the date of acceptance of this contract by the Lexington-Fayette Urban County Government. This agreement may be automatically extended for an additional 1 year(s) renewal. This contract may be canceled by either party thirty (30) days after delivery by canceling party of written notice of intent to cancel to the other contracting party.
- B. Price Changes **(Space Checked Applies)**
- (XXX)1. Prices quoted in response to the Invitation shall be firm prices for the first 90 days of the Procurement Contract. After 90 days, prices may be subject to revision and such changes shall be based on general industry changes. Revision may be either increases or decreases and may be requested by either party. There will be no more than one (1) price adjustment per quarter. Requests for price changes shall be received in writing at least twenty (20) days prior to the effective date and are subject to written acceptance before becoming effective. Proof of the validity of a request for revision shall be responsibility of the requesting party. The Lexington-Fayette Urban County Government shall receive the benefit of any decline that the seller shall offer his other accounts.
- () 2. No provision for price change is made herein. Prices are to be firm for the term of this contract.
- () 3. See bid specifications.
- C. If any contract item is not available from the vendor, the Lexington-Fayette Urban County Government, at its option, may permit the item to be back-ordered or may procure the item on the open market.
- D. All invoices must bear reference to the Lexington-Fayette Urban County Government Purchasing document numbers which are being billed.
- E. This contract may be canceled by the Lexington-Fayette Urban County Government if it is determined that the Bidder has failed to perform under the terms of this agreement, such cancellation to be effective upon receipt of written notice of cancellation by the Bidder.
- F. No substitutions for articles specified herein may be made without prior approval of the Division of Central Purchasing.

EQUAL OPPORTUNITY AGREEMENT

Standard Title VI Assurance

The Lexington Fayette-Urban County Government, (hereinafter referred to as the "Recipient") hereby agrees that as a condition to receiving any Federal financial assistance from the U.S. Department of Transportation, it will comply with Title VI of the Civil Rights Act of 1964, 78Stat.252, 42 U.S.C. 2000d-4 (hereinafter referred to as the "Act"), and all requirements imposed by or pursuant to Title 49, Code of Federal Regulations, U.S. Department of Transportation, Subtitle A, Office of the Secretary, (49 CFR, Part 21) Nondiscrimination in Federally Assisted Program of the Department of Transportation – Effectuation of Title VI of the Civil Rights Act of 1964 (hereinafter referred to as the "Regulations") and other pertinent directives, no person in the United States shall, on the grounds of race, color, national origin, sex, age (over 40), religion, sexual orientation, gender identity, veteran status, or disability be excluded from participation in, be denied the benefits of, or be otherwise subjected to discrimination under any program or activity for which the Recipient receives Federal financial assistance from the U.S. Department of Transportation, including the Federal Highway Administration, and hereby gives assurance that will promptly take any necessary measures to effectuate this agreement. This assurance is required by subsection 21.7(a) (1) of the Regulations.

The Law

- Title VII of the Civil Rights Act of 1964 (amended 1972) states that it is unlawful for an employer to discriminate in employment because of race, color, religion, sex, age (40-70 years) or national origin.
- Executive Order No. 11246 on Nondiscrimination under Federal contract prohibits employment discrimination by contractor and sub-contractor doing business with the Federal Government or recipients of Federal funds. This order was later amended by Executive Order No. 11375 to prohibit discrimination on the basis of sex.
- Section 503 of the Rehabilitation Act of 1973 states: *The Contractor will not discriminate against any employee or applicant for employment because of physical or mental disability.*
- Section 2012 of the Vietnam Era Veterans Readjustment Act of 1973 requires Affirmative Action on behalf of disabled veterans and veterans of the Vietnam Era by contractors having Federal contracts.
- Section 206(A) of Executive Order 12086, Consolidation of Contract Compliance Functions for Equal Employment Opportunity, states: *The Secretary of Labor may investigate the employment practices of any Government contractor or sub-contractor to determine whether or not the contractual provisions specified in Section 202 of this order have been violated.*

The Lexington-Fayette Urban County Government practices Equal Opportunity in recruiting, hiring and promoting. It is the Government's intent to affirmatively provide employment opportunities for those individuals who have previously not been allowed to enter into the mainstream of society. Because of its importance to the local Government, this policy carries the full endorsement of the Mayor, Commissioners, Directors and all supervisory personnel. In following this commitment to Equal Employment Opportunity and because the Government is the benefactor of the Federal funds, it is both against the Urban County Government policy and illegal for the Government to let contracts to companies which knowingly or unknowingly practice discrimination in their employment practices. Violation of the above mentioned ordinances may cause a contract to be canceled and the contractors may be declared ineligible for future consideration.

Please sign this statement in the appropriate space acknowledging that you have read and understand the provisions contained herein. Return this document as part of your application packet.

Bidders

I/We agree to comply with the Civil Rights Laws listed above that govern employment rights of minorities, women, veteran status, disability and age.

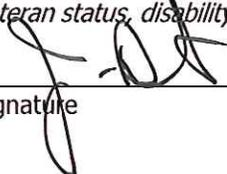

Signature

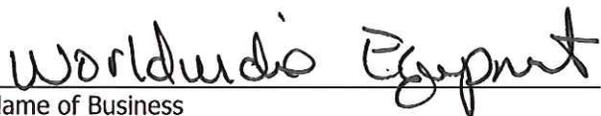

Name of Business

GENERAL PROVISIONS OF BID CONTRACT

By signing the below, bidder acknowledges that it understands and agrees with the following provisions related to its bid response and the provision of any goods or services to LFUCG upon selection by LFUCG pursuant to the bid request:

1. Bidder shall comply with all Federal, State & Local regulations concerning this type of service or good. All applicable state laws, ordinances and resolutions (including but not limited to Section 2-33 (Discrimination due to sexual orientation or gender identity) and Chapter 13 (Licenses and Regulations) of the Lexington-Fayette Urban County Government Code of Ordinances, and Resolution No. 484-17 (Minority, Women, and Veteran-Owned Businesses)) and the regulations of all authorities having jurisdiction over the project shall apply to the contract, and shall be deemed to be incorporated herein by reference.
2. Failure to submit ALL forms and information required by LFUCG may be grounds for disqualification.
3. Addenda: All addenda and IonWave Q&A, if any, must be considered by the bidder in making its response, and such addenda shall be made a part of the requirements of the bid contract. Before submitting a bid response, it is incumbent upon bidder to be informed as to whether any addenda have been issued, and the failure of the bidder to cover any such addenda may result in disqualification of that response.
4. Bid Reservations: LFUCG reserves the right to reject any or all bid responses, to award in whole or part, and to waive minor immaterial defects in proposals. LFUCG may consider any alternative proposal that meets its basic needs.
5. Liability: LFUCG is not responsible for any cost incurred by bidder in the preparation of its response.
6. Changes/Alterations: Bidder may change or withdraw a proposal at any time prior to the opening; however, no oral modifications will be allowed. Only letters, or other formal written requests for modifications or corrections of a previously submitted proposal which is addressed in the same manner as the bid response, and received by LFUCG prior to the scheduled closing time for receipt of bids, will be accepted. The bid response when opened, will then be corrected in accordance with such written request(s), provided that the written request is contained in a sealed envelope which is plainly marked "modifications of bid response".
7. Clarification of Submittal: LFUCG reserves the right to obtain clarification of any point in a bid or to obtain additional information from any bidder.
8. Bribery Clause: By his/her signature on its response, bidder certifies that no employee of his/hers, any affiliate or subcontractor, has bribed or attempted to bribe an officer or employee of the LFUCG.
9. Additional Information: While not necessary, the bidder may include any product brochures, software documentation, sample reports, or other documentation that may assist LFUCG in better understanding and evaluating the bid response. Additional documentation shall not serve as a substitute for other documentation which is required by the LFUCG to be submitted with the bid response.
10. Ambiguity, Conflict or other Errors: If a bidder discovers any ambiguity, conflict, discrepancy, omission or other error in the bid request of LFUCG, it shall immediately notify LFUCG of such error in writing and request modification or clarification of the document if allowable by the LFUCG.
11. Agreement to Bid Terms: In submitting its bid response, the bidder agrees that it has carefully examined the specifications and all provisions relating to LFUCG's bid request, including but not limited to the bid contract. By submission of its bid response, bidder states that it understands the meaning, intent and requirements of LFUCG's bid request and agrees to the same. The successful bidder shall warrant that it is familiar with and understands all provisions herein and shall warrant that it can comply with them. No additional compensation to bidder shall be authorized for services, expenses, or goods reasonably covered under these provisions that the bidder omits from its bid response.
12. Cancellation: LFUCG may unilaterally terminate the bid contract with the selected bidder(s) at any time, with or without cause, by providing at least thirty (30) days advance written notice unless a different advance

written notice period is negotiated prior to contract approval. Payment for services or goods received prior to termination shall be made by the LFUCG provided these goods or services were provided in a manner acceptable to the LFUCG. Payment for those goods and services shall not be unreasonably withheld.

13. Assignment of Contract: The selected bidder(s) shall not assign or subcontract any portion of the bid contract with LFUCG without the express written consent of LFUCG. Any purported assignment or subcontract in violation hereof shall be void. It is expressly acknowledged that LFUCG shall never be required or obligated to consent to any request for assignment or subcontract; and further that such refusal to consent can be for any or no reason, fully within the sole discretion of LFUCG.
14. No Waiver: No failure or delay by LFUCG in exercising any right, remedy, power or privilege hereunder, nor any single or partial exercise thereof, nor the exercise of any other right, remedy, power or privilege shall operate as a waiver hereof or thereof. No failure or delay by LFUCG in exercising any right, remedy, power or privilege under or in respect of this bid proposal or bid contract shall affect the rights, remedies, powers or privileges of LFUCG hereunder or shall operate as a waiver thereof.
15. Authority to do Business: Each bidder must be authorized to do business under the laws of the Commonwealth of Kentucky and must be in good standing and have full legal capacity to provide the goods or services specified in the bid proposal. Each bidder must have all necessary right and lawful authority to submit the bid response and enter into the bid contract for the full term hereof including any necessary corporate or other action authorizing the bidder to submit the bid response and enter into this bid contract. If requested, the bidder will provide LFUCG with a copy of a corporate resolution authorizing this action and/or a letter from an attorney confirming that the proposer is authorized to do business in the Commonwealth of Kentucky. All bid responses must be signed by a duly authorized officer, agent or employee of the bidder.
16. Governing Law: This bid request and bid contract shall be governed by and construed in accordance with the laws of the Commonwealth of Kentucky. In the event of any proceedings regarding this matter, the bidder agrees that the venue shall be the Fayette County Circuit Court or the U.S. District Court for the Eastern District of Kentucky, Lexington Division and that the bidder expressly consents to personal jurisdiction and venue in such Court for the limited and sole purpose of proceedings relating to these matters or any rights or obligations arising thereunder.
17. Ability to Meet Obligations: Bidder affirmatively states that there are no actions, suits or proceedings of any kind pending against bidder or, to the knowledge of the bidder, threatened against the bidder before or by any court, governmental body or agency or other tribunal or authority which would, if adversely determined, have a materially adverse effect on the authority or ability of bidder to perform its obligations under this bid response or bid contract, or which question the legality, validity or enforceability hereof or thereof.
18. Price Discrepancy: When applicable, in case of price discrepancy, unit bid price written in words will prevail followed by unit price written in numbers then total amount bid per line item.
19. Bidder understands and agrees that its employees, agents, or subcontractors are not employees of LFUCG for any purpose whatsoever. Bidder is an independent contractor at all times related to the bid response or bid contract.
20. Contractor [or Vendor or Vendor's Employees] will not appropriate or make use of the Lexington-Fayette Urban County Government (LFUCG) name or any of its trade or service marks or property (including but not limited to any logo or seal), in any promotion, endorsement, advertisement, testimonial or similar use without the prior written consent of the government. If such consent is granted LFUCG reserves the unilateral right, in its sole discretion, to immediately terminate and revoke such use for any reason whatsoever. Contractor agrees that it shall cease and desist from any unauthorized use immediately upon being notified by LFUCG.
21. If any term or provision of this bid contract shall be found to be illegal or unenforceable, the remainder of the contract shall remain in full force and such term or provision shall be deemed stricken.

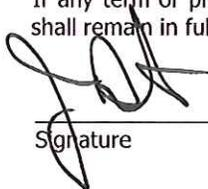

Signature

12-14-21
Date

**DIRECTOR, DIVISION OF CENTRAL PURCHASING
LEXINGTON-FAYETTE URBAN COUNTY GOVERNMENT
200 EAST MAIN STREET
LEXINGTON, KENTUCKY 40507**

**NOTICE OF REQUIREMENT FOR AFFIRMATIVE ACTION TO ENSURE
EQUAL EMPLOYMENT OPPORTUNITIES AND DBE CONTRACT PARTICIPATION**

The Lexington-Fayette Urban County Government has set a goal that not less than ten percent (10%) of the total value of this contract be subcontracted to MBE/WBE's, and set a goal that not less than three percent (3%) of the total value of this contract be subcontracted to Veteran-Owned Small Businesses. The goal for the utilization of Certified MBE/WBE's and Veteran-Owned Small Businesses as subcontractors are recommended goals. Contractors who fail to meet such goals will be expected to provide written explanations to the Director of the Division of Central Purchasing of efforts they have made to accomplish the recommended goals and the extent to which they are successful in accomplishing the recommended goals will be a consideration in the procurement process.

For assistance in locating MBE/WBE Subcontractors contact Sherita Miller at 859/258-3320 or by writing the address listed below:

Sherita Miller, Division of Central Purchasing
Lexington-Fayette Urban County Government
200 East Main Street – Room 338
Lexington, Kentucky 40507
smiller@lexingtonky.gov

Lexington-Fayette Urban County Government
MWDBE PARTICIPATION GOALS

A. GENERAL

- 1) The LFUCG request all potential contractors to make a concerted effort to include Minority-Owned (MBE), Woman-Owned (WBE), Disadvantaged (DBE) Business Enterprises and Veteran-Owned Small Businesses (VOSB) as subcontractors or suppliers in their bids.
- 2) Toward that end, the LFUCG has established 10% of total procurement costs as a Goal for participation of Minority-Owned, Woman-Owned and Disadvantaged Businesses on this contract.
- 3) **It is therefore a request of each Bidder to include in its bid, the same goal (10%) for MWDBE participation and other requirements as outlined in this section.**
- 4) The LFUCG has also established a 3% of total procurement costs as a Goal for participation for of Veteran-Owned Businesses.
- 5) **It is therefore a request of each Bidder to include in its bid, the same goal (3%) for Veteran-Owned participation and other requirements as outlined in this section.**

B. PROCEDURES

- 1) The successful bidder will be required to report to the LFUCG, the dollar amounts of all payments submitted to Minority-Owned, Woman-Owned or Veteran-Owned subcontractors and suppliers for work done or materials purchased for this contract. (See Subcontractor Monthly Payment Report)
- 2) Replacement of a Minority-Owned, Woman-Owned or Veteran-Owned subcontractor or supplier listed in the original submittal must be requested in writing and must be accompanied by documentation of Good Faith Efforts to replace the subcontractor / supplier with another MWDBE Firm; this is subject to approval by the LFUCG. (See LFUCG MWDBE Substitution Form)
- 3) For assistance in identifying qualified, certified businesses to solicit for potential contracting opportunities, bidders may contact:
 - a) The Lexington-Fayette Urban County Government, Division of Central Purchasing (859-258-3320)
- 4) The LFUCG will make every effort to notify interested MWDBE and Veteran-Owned subcontractors and suppliers of each Bid Package, including information on the scope of work, the pre-bid meeting time and location, the bid date, and all other pertinent information regarding the project.

C. DEFINITIONS

- 1) A Minority-Owned Business Enterprise (MBE) is defined as a business which is certified as being at least 51% owned, managed and controlled by persons of African American, Hispanic, Asian, Pacific Islander, American Indian or Alaskan Native Heritage.
- 2) A Woman-Owned Business Enterprise (WBE) is defined as a business which is certified as being at least 51% owned, managed and controlled by one or more women.
- 3) A Disadvantaged Business (DBE) is defined as a business which is certified as being at least

51% owned, managed and controlled by a person(s) that are economically and socially disadvantaged.

- 4) A Veteran-Owned Small Business (VOSB) is defined as a business which is certified as being at least 51% owned, managed and controlled by a veteran and/or a service disabled veteran.
- 5) Good Faith Efforts are efforts that, given all relevant circumstances, a bidder or proposer actively and aggressively seeking to meet the goals, can reasonably be expected to make. In evaluating good faith efforts made toward achieving the goals, whether the bidder or proposer has performed the efforts outlined in the Obligations of Bidder for Good Faith Efforts outlined in this document will be considered, along with any other relevant factors.

D. OBLIGATION OF BIDDER FOR GOOD FAITH EFFORTS

- 1) **The bidder shall make a Good Faith Effort to achieve the Participation Goal for MWDBE and Veteran-Owned subcontractors/suppliers. The failure to meet the goal shall not necessarily be cause for disqualification of the bidder; however, bidders not meeting the goal are required to furnish with their bids written documentation of their Good Faith Efforts to do so.**
- 2) Award of Contract shall be conditioned upon satisfaction of the requirements set forth herein.
- 3) The Form of Proposal includes a section entitled "MWDBE Participation Form". The applicable information must be completed and submitted as outlined below.
- 4) **Failure to submit this information as requested may be cause for rejection of bid or delay in contract award.**

E. DOCUMENTATION REQUIRED FOR GOOD FAITH EFFORTS

- 1) Bidders reaching the Goal are required to submit only the MWDBE Participation Form." The form must be fully completed including names and telephone number of participating MWDBE firm(s); type of work to be performed; estimated value of the contract and value expressed as a percentage of the total Lump Sum Bid Price. The form must be signed and dated, and is to be submitted with the bid.
- 2) Bidders not reaching the Goal must submit the "MWDBE Participation Form", the "Quote Summary Form" and a written statement documenting their Good Faith Effort to do so. If bid includes no MWDBE and/or Veteran participation, bidder shall enter "None" on the subcontractor / supplier form). In addition, the bidder must submit written proof of their Good Faith Efforts to meet the Participation Goal:
 - a. Advertised opportunities to participate in the contract in at least two (2) publications of general circulation media; trade and professional association publications; small and minority business or trade publications; and publications or trades targeting minority, women and disadvantaged businesses not less than fifteen (15) days prior to the deadline for submission of bids to allow MWDBE firms and Veteran-Owned businesses to participate.
 - b. Included documentation of advertising in the above publications with the bidders good faith efforts package
 - c. Attended LFUCG Central Purchasing Economic Inclusion Outreach event

- d. Attended pre-bid meetings that were scheduled by LFUCG to inform MWDBEs and/or Veteran-Owned businesses of subcontracting opportunities
- e. Sponsored Economic Inclusion event to provide networking opportunities for prime contractors and MWDBE firms and Veteran-Owned businesses.
- f. Requested a list of MWDBE and/or Veteran subcontractors or suppliers from LFUCG and showed evidence of contacting the companies on the list(s).
- g. Contacted organizations that work with MWDBE companies for assistance in finding certified MWDBE firms and Veteran-Owned businesses to work on this project. Those contacted and their responses should be a part of the bidder's good faith efforts documentation.
- h. Sent written notices, by certified mail, email or facsimile, to qualified, certified MWDBEs and/or Veteran-Owned businesses soliciting their participation in the contract not less than seven (7) days prior to the deadline for submission of bids to allow them to participate effectively.
- i. Followed up initial solicitations by contacting MWDBEs and Veteran-Owned Businesses to determine their level of interest.
- j. Provided the interested MWDBE firm and/or Veteran-Owned business with adequate and timely information about the plans, specifications, and requirements of the contract.
- k. Selected portions of the work to be performed by MWDBE firms and/or Veteran-Owned businesses in order to increase the likelihood of meeting the contract goals. This includes, where appropriate, breaking out contract work items into economically feasible units to facilitate MWDBE and Veteran participation, even when the prime contractor may otherwise perform these work items with its own workforce
- l. Negotiated in good faith with interested MWDBE firms and Veteran-Owned businesses not rejecting them as unqualified without sound reasons based on a thorough investigation of their capabilities. Any rejection should be so noted in writing with a description as to why an agreement could not be reached.
- m. Included documentation of quotations received from interested MWDBE firms and Veteran-Owned businesses which were not used due to uncompetitive pricing or were rejected as unacceptable and/or copies of responses from firms indicating that they would not be submitting a bid.
- n. Bidder has to submit sound reasons why the quotations were considered unacceptable. The fact that the bidder has the ability and/or desire to perform the contract work with its own forces will not be considered a sound reason for rejecting a MWDBE and/or Veteran-Owned business's quote. Nothing in this provision shall be construed to require the bidder to accept unreasonable quotes in order to satisfy MWDBE and Veteran goals.
- o. Made an effort to offer assistance to or refer interested MWDBE firms and Veteran-Owned businesses to obtain the necessary equipment, supplies, materials, insurance and/or

bonding to satisfy the work requirements of the bid proposal

p. Made efforts to expand the search for MWBE firms and Veteran-Owned businesses beyond the usual geographic boundaries.

q. Other--any other evidence that the bidder submits which may show that the bidder has made reasonable good faith efforts to include MWDBE and Veteran participation.

Note: Failure to submit any of the documentation requested in this section may be cause for rejection of bid. Bidders may include any other documentation deemed relevant to this requirement which is subject to review by the MBE Liaison. Documentation of Good Faith Efforts must be submitted with the Bid, if the participation Goal is not met.



MINORITY BUSINESS ENTERPRISE PROGRAM

Sherita Miller, MPA
Minority Business Enterprise Liaison
Division of Central Purchasing
Lexington-Fayette Urban County Government
200 East Main Street
Lexington, KY 40507
smiller@lexingtonky.gov
859-258-3323

OUR MISSION: The mission of the Minority Business Enterprise Program is to facilitate the full participation of minority and women owned businesses in the procurement process and to promote economic inclusion as a business imperative essential to the long term economic viability of Lexington-Fayette Urban County Government.

To that end the city council adopted and implemented Resolution 484-2017 – A Certified Minority, Women and Disadvantaged Business Enterprise ten percent (10%) minimum goal and a three (3%) minimum goal for Certified Veteran-Owned Small Businesses and Certified Service Disabled Veteran – Owned Businesses for government contracts.

The resolution states the following definitions shall be used for the purposes of reaching these goals (a full copy is available in Central Purchasing):

Certified Disadvantaged Business Enterprise (DBE) – a business in which at least fifty-one percent (51%) is owned, managed and controlled by a person(s) who is socially and economically disadvantaged as defined by 49 CFR subpart 26.

Certified Minority Business Enterprise (MBE) – a business in which at least fifty-one percent (51%) is owned, managed and controlled by an ethnic minority (i.e. African American, Asian American/Pacific Islander, Hispanic Islander, Native American/Native Alaskan Indian) as defined in federal law or regulation as it may be amended from time-to-time.

Certified Women Business Enterprise (WBE) – a business in which at least fifty-one percent (51%) is owned, managed and controlled by a woman.

Certified Veteran-Owned Small Business (VOSB) – a business in which at least fifty-one percent (51%) is owned, managed and controlled by a veteran who served on active duty with the U.S. Army, Air Force, Navy, Marines or Coast Guard.

Certified Service Disabled Veteran Owned Small Business (SDVOSB) – a business in which at least fifty-one percent (51%) is owned, managed and controlled by a disabled veteran who served on active duty with the U.S. Army, Air Force, Navy, Marines or Coast Guard.

The term “Certified” shall mean the business is appropriately certified, licensed, verified, or validated by an organization or entity recognized by the Division of Purchasing as having the appropriate credentials to make a determination as to the status of the business.

To comply with Resolution 484-2017, prime contractors and minority, women and veteran owned businesses must enroll in the new Diverse Business Management Compliance system, <https://lexingtonky.diversitycompliance.com/>

We have compiled the list below to help you locate certified MBE, WBE and DBE certified businesses. Below is a listing of contacts for LFUCG Certified MWDBEs and Veteran-Owned Small Businesses in <https://lexingtonky.ionwave.net>

Business	Contact	Email Address	Phone
LFUCG	Sherita Miller	smiller@lexingtonky.gov	859-258-3323
Commerce Lexington – Minority Business Development	Tyrone Tyra	tyra@commercelexington.com	859-226-1625
Tri-State Minority Supplier Diversity Council	Susan Marston	smarston@tsmsdc.com	502-365-9762
Small Business Development Council	Shawn Rogers UK SBDC	shawn.rogers@uky.edu	859-257-7666
Community Ventures Corporation	Phyllis Alcorn	palcorn@cvky.org	859-231-0054
KY Transportation Cabinet (KYTC)	Melvin Byne	Melvin.bynes2@ky.gov	502-564-3601
KYTC Pre-Qualification	Shella Eagle	Shella.Eagle@ky.gov	502-782-4815
Ohio River Valley Women’s Business Council (WBENC)	Sheila Mixon	smixon@orwbc.org	513-487-6537
Kentucky MWBE Certification Program	Yvette Smith, Kentucky Finance Cabinet	Yvette.Smith@ky.gov	502-564-8099
National Women Business Owner’s Council (NWBOC)	Janet Harris-Lange	janet@nwbo.org	800-675-5066
Small Business Administration	Robert Coffey	robertcoffey@sba.gov	502-582-5971
LaVoz de Kentucky	Andres Cruz	lavozydeky@yahoo.com	859-621-2106
The Key News Journal	Patrice Muhammad	production@keynewsjournal.com	859-685-8488

WORKFORCE ANALYSIS FORM

Name of Organization: Worldwide Equipment

Categories	Total	White (Not Hispanic or Latino)		Hispanic or Latino		Black or African-American (Not Hispanic or Latino)		Native Hawaiian and Other Pacific Islander (Not Hispanic or Latino)		Asian (Not Hispanic or Latino)		American Indian or Alaskan Native (not Hispanic or Latino)		Two or more races (Not Hispanic or Latino)		Total	
		M	F	M	F	M	F	M	F	M	F	M	F	M	F	M	F
Administrators																	
Professionals		12															
Superintendents																	
Supervisors		3					1										
Foremen		2															
Technicians		10															
Protective Service																	
Para-Professionals																	
Office/Clerical		3	1				1										
Skilled Craft																	
Service/Maintenance		2															
Total:		29	1			1	1										

Prepared by: Amel Abou G.M. Date: 12/14/21
 (Name and Title)

Revised 2015-Dec-15



LFUCG MWDBE PARTICIPATION FORM

Bid/RFP/Quote Reference # 125-2021

The MWDBE and/or veteran subcontractors listed have agreed to participate on this Bid/RFP/Quote. If any substitution is made or the total value of the work is changed prior to or after the job is in progress, it is understood that those substitutions must be submitted to Central Purchasing for approval immediately. **Failure to submit a completed form may cause rejection of the bid.**

MWDBE Company, Name, Address, Phone, Email	MBE WBE or DBE	Work to be Performed	Total Dollar Value of the Work	% Value of Total Contract
1.				
2.				
3.				
4.				

The undersigned company representative submits the above list of MWDBE firms to be used in accomplishing the work contained in this Bid/RFP/Quote. Any misrepresentation may result in the termination of the contract and/or be subject to applicable Federal and State laws concerning false statements and false claims.

Worldwide Equipment
Company

12-14-21
Date

[Signature]
Company Representative
G.M.
Title



LEXINGTON

LFUCG MWDBE PARTICIPATION FORM

Bid/RFP/Quote Reference # 125-2021

The MWDBE and/or veteran subcontractors listed have agreed to participate on this Bid/RFP/Quote. If any substitution is made or the total value of the work is changed prior to or after the job is in progress, it is understood that those substitutions must be submitted to Central Purchasing for approval immediately. **Failure to submit a completed form may cause rejection of the bid.**

MWDBE Company, Name, Address, Phone, Email	MBE WBE or DBE	Work to be Performed	Total Dollar Value of the Work	% Value of Total Contract
1.				
2.				
3.				
4.				

The undersigned company representative submits the above list of MWDBE firms to be used in accomplishing the work contained in this Bid/RFP/Quote. Any misrepresentation may result in the termination of the contract and/or be subject to applicable Federal and State laws concerning false statements and false claims.

Worldwide Egypt
Company

JDA
Company Representative

12-14-21
Date

EM
Title



LEXINGTON

LFUCG MWDBE SUBSTITUTION FORM

Bid/RFP/Quote Reference # 125-2021

The substituted MWDBE and/or veteran subcontractors listed below have agreed to participate on this Bid/RFP/Quote. These substitutions were made prior to or after the job was in progress. These substitutions were made for reasons stated below and are now being submitted to Central Purchasing for approval. By the authorized signature of a representative of our company, we understand that this information will be entered into our file for this project. **Failure to submit this form may cause rejection of the bid.**

SUBSTITUTED MWDBE Company Name, Address, Phone, Email	MWDBE Formally Contracted/ Name, Address, Phone, Email	Work to Be Performed	Reason for the Substitution	Total Dollar Value of the Work	% Value of Total Contract
1.					
2.					
3.					
4.					

The undersigned acknowledges that any misrepresentation may result in termination of the contract and/or be subject to applicable Federal and State laws concerning false statements and false claims.

Worldwide Export
Company

12-24-21
Date

Date

[Signature]
Company Representative

G.M.
Title

Title



LEXINGTON

MWDBE QUOTE SUMMARY FORM

Bid/RFP/Quote Reference # 125-2021

The undersigned acknowledges that the minority and/or veteran subcontractors listed on this form did submit a quote to participate on this project. Failure to submit this form may cause rejection of the bid.

Company Name <u>Worldwide Export</u>	Contact Person <u>Jim Butson</u>
Address/Phone/Email <u>945 Nevada Lex Ky 40511</u>	Bid Package / Bid Date <u>125-2021 12-16-21</u>

MWDBE Company Address	Contact Person	Contact Information (work phone Email, cell)	Date Contacted	Services to be performed	Method of Communication (email, phone meeting, ad, event etc)	Total dollars \$\$ Do Not Leave Blank (Attach Documentation)	MBE * AA HA AS NA Female	Veteran

(MBE designation / AA=African American / HA= Hispanic American/AS = Asian American/Pacific Islander/ NA= Native American)

The undersigned acknowledges that all information is accurate. Any misrepresentation may result in termination of the contract and/or be subject to applicable Federal and State laws concerning false statements and claims.

Worldwide Export
 Company
12-14-21
 Date

[Signature]
 Company Representative
G.M.
 Title



LEXINGTON

LFUCG SUBCONTRACTOR MONTHLY PAYMENT REPORT

The LFUCG has a 10% goal plan adopted by city council to increase the participation of minority and women owned businesses in the procurement process. The LFUCG also has a 3% goal plan adopted by cited council to increase the participation of veteran owned businesses in the procurement process. In order to measure that goal LFUCG will track spending with MWDBE and Veteran contractors on a monthly basis. By the signature below of an authorized company representative, you certify that the information is correct, and that each of the representations set forth below is true. Any misrepresentation may result in termination of the contract and/or prosecution under applicable Federal and State laws concerning false statements and false claims. Please submit this form monthly to the Division of Central Purchasing/ 200 East Main Street / Room 338 / Lexington, KY 40507.

Bid/RFP/Quote # 125-2021
 Total Contract Amount Awarded to Prime Contractor for this Project _____

Project Name/ Contract #	Work Period/ From: _____ To: _____
Company Name:	Address:
Federal Tax ID:	Contact Person:

Subcontractor Vendor ID (name, address, phone, email)	Description of Work	Total Subcontract Amount	% of Total Contract Awarded to Prime for this Project	Total Amount Paid for this Period	Purchase Order number for subcontractor work (please attach PO)	Scheduled Project Start Date	Scheduled Project End Date

By the signature below of an authorized company representative, you certify that the information is correct, and that each of the representations set forth below is true. Any misrepresentations may result in the termination of the contract and/or prosecution under applicable Federal and State laws concerning false statements and false claims.

Workforce Report
 Company _____
12-14-21
 Date _____

[Signature]
 Company Representative _____
G.M.
 Title _____

LFUCG STATEMENT OF GOOD FAITH EFFORTS

Bid/RFP/Quote # 125-2021

By the signature below of an authorized company representative, we certify that we have utilized the following Good Faith Efforts to obtain the maximum participation by MWDBE and Veteran-Owned business enterprises on the project and can supply the appropriate documentation.

_____ Advertised opportunities to participate in the contract in at least two (2) publications of general circulation media; trade and professional association publications; small and minority business or trade publications; and publications or trades targeting minority, women and disadvantaged businesses not less than fifteen (15) days prior to the deadline for submission of bids to allow MWDBE firms and Veteran-Owned businesses to participate.

_____ Included documentation of advertising in the above publications with the bidders good faith efforts package

_____ Attended LFUCG Central Purchasing Economic Inclusion Outreach event

_____ Attended pre-bid meetings that were scheduled by LFUCG to inform MWDBEs and/or Veteran-Owned Businesses of subcontracting opportunities

_____ Sponsored Economic Inclusion event to provide networking opportunities for prime contractors and MWDBE firms and Veteran-Owned businesses

_____ Requested a list of MWDBE and/or Veteran subcontractors or suppliers from LFUCG and showed evidence of contacting the companies on the list(s).

_____ Contacted organizations that work with MWDBE companies for assistance in finding certified MWBDE firms and Veteran-Owned businesses to work on this project. Those contacted and their responses should be a part of the bidder's good faith efforts documentation.

_____ Sent written notices, by certified mail, email or facsimile, to qualified, certified MWDBEs soliciting their participation in the contract not less than seven (7) days prior to the deadline for submission of bids to allow them to participate effectively.

_____ Followed up initial solicitations by contacting MWDBEs and Veteran-Owned businesses to determine their level of interest.

_____ Provided the interested MWBDE firm and/or Veteran-Owned business with adequate and timely information about the plans, specifications, and requirements of the contract.

_____ Selected portions of the work to be performed by MWDBE firms and/or Veteran-Owned businesses in order to increase the likelihood of meeting the contract goals. This includes, where appropriate, breaking out contract work items into economically feasible units to facilitate MWDBE and Veteran participation, even when the prime contractor may otherwise perform these work items with its own workforce

_____ Negotiated in good faith with interested MWDBE firms and Veteran-Owned businesses not rejecting them as unqualified without sound reasons based on a thorough investigation of their capabilities. Any rejection should be so noted in writing with a description as to why an agreement could not be reached.

_____ Included documentation of quotations received from interested MWDBE firms and Veteran-Owned businesses which were not used due to uncompetitive pricing or were rejected as unacceptable and/or copies of responses from firms indicating that they would not be submitting a bid.

_____ Bidder has to submit sound reasons why the quotations were considered unacceptable. The fact that the bidder has the ability and/or desire to perform the contract work with its own forces will not be considered a sound reason for rejecting a MWDBE and/or Veteran-Owned business's quote. Nothing in this provision shall be construed to require the bidder to accept unreasonable quotes in order to satisfy MWDBE and Veteran goals.

_____ Made an effort to offer assistance to or refer interested MWDBE firms and Veteran-Owned businesses to obtain the necessary equipment, supplies, materials, insurance and/or bonding to satisfy the work requirements of the bid proposal

_____ Made efforts to expand the search for MWBE firms and Veteran-Owned businesses beyond the usual geographic boundaries.

_____ Other--any other evidence that the bidder submits which may show that the bidder has made reasonable good faith efforts to include MWDBE and Veteran participation.

NOTE: Failure to submit any of the documentation requested in this section may be cause for rejection of bid. Bidders may include any other documentation deemed relevant to this requirement which is subject to approval by the MBE Liaison. Documentation of Good Faith Efforts must be submitted with the Bid, if the participation Goal is not met.

The undersigned acknowledges that all information is accurate. Any misrepresentations may result in termination of the contract and/or be subject to applicable Federal and State laws concerning false statements and claims.

Worldwide Egypt
Company

[Signature]
Company Representative

12-14-01
Date

G.M.
Title

TECHNICAL SPECIFICATION

LR 64R G

APPLICATION PACKAGES			DESCRIPTION	WEIGHT (LB)	
				FRONT	REAR
MPK1UK	CHASSIS CONFIGURATION PACKAGE		Vertical BOC CNG/LNG Emission Unit, LH Battery Box, Omitted Fuel Tanks	0	0

CUSTOMER/VEHICLE INFO			DESCRIPTION	WEIGHT (LB)	
				FRONT	REAR
S	0029W2	CHASSIS (BASE MODEL)	LR 64R G DAYCAB	7,474	1,537
S	MP2001	CUSTOMER FLEET SIZE	DEALER FLEET WITH LESS THAN 25 VEHICLES IN OWN FLEET OF ANY VEHICLE BRAND	0	0
S	013001	TYPE OF SERVICE	COMMERCIAL	0	0
S	M98018	WARRANTY REGISTRATION LOCATION	US - WARRANTY REGISTRATION LOCATION	0	0
	MBT03T	EMISSION WARRANTY CERTIFICATION	CARB + EPA Cummins Gas	0	0
S	5050B5	INITIAL REGISTRATION LOCATION	USA REGISTRATION	0	0
S	APPAA3	VEHICLE APPLICATION CLASS	CLASS B HIGHWAY-INNER CITY	0	0
	0050S5	VEHICLE USE & BODY/TRAILER TYPE	REFUSE FRONT LOADER TRUCK	0	0
S	032A39	TERRAIN GRADE	NORMAL HIGHWAY, STARTING GRADES<12%	0	0
S	033A10	LOADING SURFACE	CONCRETE LOADING AND / OR UNLOADING SURFACE	0	0
	0342A3	VEHICLE VOCATION	REFUSE / NON LANDFILL OPERATION	0	0

ENGINE/TRANSMISSIONS			DESCRIPTION	WEIGHT (LB)	
				FRONT	REAR
S	1003O0	ENGINE PACKAGE, COMBUSTION	L9N-G 320 CUMMINS-NZ 320HP @ 2000 RPM (PEAK) 2200 RPM (GOV), 1000 LB-FT, US'21	1,608	84
S	136AS6	TRANSMISSION	4500 RDS 6 SP-ALLISON RUGGED DUTY SERIES GEN 5 W/PROGNOSTICS	732	245

EXHAUST/EMISSIONS			DESCRIPTION	WEIGHT (LB)	
				FRONT	REAR
S	130AC7	EXHAUST	SINGLE VERTICAL RIGHT SIDE OUTBOARD MOUNTED STRAIGHT EXH STACK PLAIN END, SIDE OUTLET DIFFUSER	0	0
S	Q0AA1X	EXHAUST SYSTEM MATERIAL FINISH	W/O VERT EXH-BRIGHT FINISH	0	0
	78AC7X	EMISSION ON BOARD DIAG CONTROL	EMISSION OBD, DISPLAY ONLY, USA2018	0	0

ENGINE EQUIPMENT			DESCRIPTION	WEIGHT (LB)	
				FRONT	REAR
S	1250E5	AIR CLEANER	15" SINGLE ELEMENT, DRY TYPE, AIR RESTRICTION INDICATOR ON FILTER	0	0
S	H8XA1X	WINTERFRONT	FURNISH WINTER FRONT GRILLE COVER	0	0
	113023	AIR COMPRESSOR/DRYER	BENDIX IP EP AIR DRYER W/ CUMMINS TWIN (30.4 CFM) AIR COMPRESSOR	0	0
S	KOXA1X	AIR DRYER POSITION (CA)	AIR DRYER POSITION STANDARD	0	0
CA	132AD4	ALTERNATOR	DELCO 12V 200A (28SI) BRUSH-TYPE W/ REMOTE VOLTAGE SENSING	18	0
S	316AA6	BATTERIES	(3) MACK 12V 650/1950 CCA THREADED STUD TYPE	0	0
S	393AD9	BATTERY BOX - MOUNTING	PERPENDICULAR TO FRAME 11" FROM NTOF (3 BATTERY MAX)	0	0
S	L5XA1X	BATTERY BOX COVER	MOLDED PLASTIC	0	0
	LLXC1X	EMERGENCY START CONNECTIONS	EMERGENCY START STUDS, BATTERY BOX MOUNTED	7	0

TECHNICAL SPECIFICATION *(cont.)*



ENGINE EQUIPMENT		DESCRIPTION	WEIGHT (LB)		
			FRONT	REAR	
S	318AA3	BATTERY DISCONNECT SWITCH	FLAMING RIVER BIG SWITCH WIRED TO POSITIVE SIDE	0	0
S	NCXA5X	STARTER MOTOR	12 VOLT DELCO 39MT-MXT	31	0
S	118038	FAN DRIVE	HORTON FAN, "ON-OFF"	0	0
S	119AH9	COOLANT PROTECTION	ETHYLENE GLYCOL EXTENDED LIFE COOLANT (50/50 MIX DYED RED) TO -34DEG	0	0
	508AA1	COOLING PERFORMANCE	WITH AUXILIARY COOLING	80	-15
	H9XN1X	RADIATOR TYPE	EXTRA NARROW RADIATOR WITH LENGTH 1 (60 DM2)	0	0
S	124AA2	HOSES - RADIATOR/HEATER	SILICONE RADIATOR AND HEATER HOSES	0	0
S	293AC1	FUEL-WATER SEPARATOR	CUMMINS CNG COALESCING FUEL FILTER, STANCHION MOUNTED ON FRAME	0	0
S	MCA09A	ENGINE HEATERS	CUMMINS BLOCK HEATER + W/O OIL PAN HEATER	0	0
S	4TBA1X	ENGINE BLOCK HEATER RECEPTACLE (CA)	ENGINE BLOCK HEATER RECEPTACLE, BASIC LOCATION	0	0
S	36AB1X	TETHER DEV PKG, CAPS & COVERS	PLASTIC COATED CABLE, MOUNTED FRONT OF EACH BATTERY BOX LENGTH TO ALLOW COVER TO SET ON GROUND	0	0

CLUTCH/TRANS EQUIPMENT		DESCRIPTION	WEIGHT (LB)		
			FRONT	REAR	
S	195AA9	DRIVELINE - MAIN	MERITOR 176 MXL "XTENDED LUBE" (PROPS-M)	3	3
S	204AA5	DRIVELINE - INTERAXLE	MERITOR 17 MXL "XTENDED LUBE"	0	0
S	76AA1X	PROPELLR SHAFT MAIN, UNVSL JNT	UNIVERSAL JOINT HALF-ROUND TYPE	0	0
S	8WAAAX	PROP SHAFT INTERAXL UNIV JOINT	HALF-ROUND UNIVERSAL JOINT	0	0
S	7RXAEX	LUBRICANTS, TRANSMISSION	TRANSYND SYNTHETIC LUBE FOR ALLISON TRANS	0	0
S	139AA6	TRANSMISSION OIL COOLER	REMOTE MOUNTED OIL COOLER FURNISH FOR ALLISON TRANSMISSION	0	0

FRONT AXLE EQUIPMENT		DESCRIPTION	WEIGHT (LB)		
			FRONT	REAR	
S	240AA3	FRONT AXLE	20000# (9100 KG) MACK FXL20 WIDE PIVOT CENTER STRAIGHT SPINDLE/UNITIZED BEARINGS	0	0
S	244AB4	SPRINGS - FRONT	MACK TAPERLEAF 20000# (9100 KG) GROUND LOAD RATING, EQUAL BIAS	0	0
CA	241041	FRONT AXLE BRAKES	MERITOR "S" CAM 16.5" X 7" Q-PLUS BRAKES	0	0
S	U0AA1X	FRONT BRAKE ADJ. MANUFACTURE	HALDEX - AUTOMATIC	0	0
S	V7AD1X	FRONT BRAKE CHAMBER MFG.	FRONT BRAKE CHAMBER MANUFACTURER, MGM	0	0
S	0KXA1X	HUB MATERIAL, FRONT	FERROUS	0	0
S	1KAA1X	SHOCK ABSORBER, FRONT	DOUBLE ACTING TYPE	20	0
S	245AA6	STEERING	M100P PLUS RIGHT SIDE ASSIST CYLINDER	142	0
S	2SAA1X	BUMP STOP, FRONT SUSPENSION	STATIC LOAD CUSHIONS	0	0

REAR AXLE EQUIPMENT		DESCRIPTION	WEIGHT (LB)		
			FRONT	REAR	
	268AA9	REAR AXLE	46000# (20900kg) MACK S462R CAST DUCTILE HOUSING	0	1,614
S	6MAA1X	REAR AXLE CASING WIDTH	W/O WIDE TRACK AXLE	0	0
S	018AA6	CARRIER - REAR AXLE	CRDP150/151 AVAILABLE WITH OPTIONAL DRIVER CONTROLLED INTERWHEEL DIFFERENTIAL LOCKS, SEE 254 SYMBOL	0	0
	TAX2FX	REAR AXLE RATIO	5.31 RATIO	0	0
	1860K6	REAR SUSPENSION	SS46 MACK CAMELBACK MULTILEAF 46,000 lb, HEAVY DUTY	0	1,930

TECHNICAL SPECIFICATION (cont.)



			WEIGHT (LB)		
REAR AXLE EQUIPMENT		DESCRIPTION	FRONT	REAR	
	402AA3	SPRINGS - ANTI-SWAY	SPRINGS, ANTI-SWAY	0	106
	XZXA1X	REAR SUSP. BEAM BUSHINGS	BRONZE	0	36
S	GWXABX	BOGIE SPREAD, REAR	50" AXLE SPACING (BOGIE WHEELBASE)	0	0
S	XYXB1X	TRANSVERSE TORQUE RODS, R SUSP	TRANSVERSE TORQUE ROD (REAR AXLE ONLY)	0	67
	253005	BRAKES - REAR	MERITOR - CAM 16.5"x8.0" Q+ (Total for QTY = 2)	0	0
S	U4XA1X	BRAKE, DRIVE, REAR	CAST IRON	0	0
S	U1AA1X	REAR BRAKE ADJ MANUFACTURE	HALDEX - AUTOMATIC	0	0
	V1AB1X	REAR BRAKE CHAMBER SIZE	REAR SPRING BRAKE CHAMBERS 30/30 TYPE	0	0
	N5FAJX	BRAKE ORI REAR-MOST DRIVE AXLE	DRUM BRAKE CHAMBER ORIENTATION: High Mount - Rear of Axle - Chamber Down	0	0
S	300AB8	PARKING BRAKE CHAMBER	MGM TR3030LP3THD BRAKE CHAMBERS (Total for QTY = 2)	0	0
S	3GAA1X	BRAKE CHAMBER DIAPHRAGM MATERIAL (CA in PC28 only)	W/O BRAKE DIAPHRAGM OPTION	0	0
S	0LXI5X	HUB MATERIAL, DRIVE	IRON PRESET REAR HUB W/INTEGRATED SPINDLE NUT	0	0
S	N2AE1X	SPINDLE NUTS, MAIN AXLE	SPINDLE NUTS, MAIN AXLE, INTEGRATED	0	0
S	3LAC1X	POWER DIVIDER LOCKOUT	POWER DIVIDER LOCKOUT, W/BUZZER & LIGHT	0	40
S	7WXA1X	LUBRICANTS, REAR AXLE(S)	FACTORY OPTION LUBE - REAR AXLE 80W-90	0	0
S	698058	ANTILOCK BRAKE SYSTEM	BENDIX WITHOUT TRACTION CONTROL 4S4M	0	0

			WEIGHT (LB)		
FRAME EQUIPMENT/FUEL TANKS		DESCRIPTION	FRONT	REAR	
	271210	WHEELBASE	210"	247	247
	374067	AF (OVERHANG)	67"	-17	106
	MCE0LE	FRAME RAILS & LINERS	9.5 x 82 x 340mm - (0.375" x 3.25" x 13.38")W/ Full Liner; RBM 3,122,400 LB-IN	0	0
S	A0XABX	FRONT FRAME LENGTH	FRONT FRAME LENGTH 1525MM	146	-19
S	281A1I	CROSSMEMBERS	STEEL 1/2" PL BOLTED BOC & INTERMDT 1/8" BELOW TOP OF RAIL	0	0
	9DEZ1X	AUX CROSSM. IN REAR OVERH TYPE	WITHOUT AUXILIARY CROSSMEMBER	0	0
S	Q5AA1X	REAR CROSSMEMBER OPTIONS	STEEL CLOSING REAR CROSSMEMBER	0	0
S	4DXA6X	FRONT BUMPER	FLUSH-PAINTED STEEL	0	0
S	5EXF1X	GUARD	SKID PLATE UNDER BUMPER AND RADIATOR	128	-8
S	4EXD1X	TOWING DEVICE, FRONT	CENTER TOW CAPABILITY BASED ON BUMPER SELECTION	0	0
S	288AE9	FUEL TANK - LH	DELETE LH FUEL DIESEL TANK - FOR LOCAL COMPLETION & CERTIFICATION OF CNG SYSTEM	0	0
S	290AF4	FUEL TANK - RH	DELETE RH DIESEL TANK - FOR LOCAL COMPLETION & CERTIFICATION OF CNG SYSTEM	0	0
S	JHXH1X	FUEL HOSES, LIQUID	HIGH PRESSURE HOSES	0	0
S	HBXA1X	FUEL TANK POSITION (CA in PC28 only)	W/O RELOCATED FUEL TANK(S)	0	0

			WEIGHT (LB)		
AIR/BRAKE		DESCRIPTION	FRONT	REAR	
S	UWXA1X	AIRTANK DRAIN VALVE	AUTO DRAIN VALVE, HEATED ON SUPPLY TANK, MANUAL (PETCOCK) ON ALL OTHER TANKS	0	0
	U2XA1X	AIRTANK MATERIAL	ALUMINUM AIR TANK PAINTED CHASSIS COLOR	-24	0
S	1JAAAX	PARKING BRAKE VALVE	SINGLE VALVE SYSTEM	0	0

TECHNICAL SPECIFICATION *(cont.)*



				WEIGHT (LB)	
ELECTRICAL		DESCRIPTION		FRONT	REAR
S	5RXA8X	BACK-UP ALARM	PRECO, MODEL 1059	0	3
S	312006	ROOF & SIDE MARKER LIGHTS	TRUCKLIGHT TYPE ROOF MARKER for LR	0	0
S	LJXB1X	HEADLAMP BULB TYPE	HEADLAMP BULB TYPE, LED	0	0
S	LSXH2X	DAYTIME RUNNING LIGHTS	ENGINE RUNNING ACTIVATED	0	0
S	M4XAAX	AUX. POWER OUTLET, INTERIOR (CA in PC28 only)	COMPUTER AND 2-WAY RADIO DEDICATED CIRCUIT	0	0
S	3BCB1X	FRONT & SIDE INDICATOR LMP TYP	FRONT AND SIDE DIRECTION IND & MARKER, LED TYPE	3	0

				WEIGHT (LB)	
TRAILER CONNECTIONS		DESCRIPTION		FRONT	REAR
S	4BAA1X	EXT. INDICATOR LMP, MAIN SWITCH (CA in PC28 only)	FURNISH ON OR NEAR BATTERY BOX (LIGHT ON IN RUN POSITION)	0	0

				WEIGHT (LB)	
PTO		DESCRIPTION		FRONT	REAR
	826086	HYDRAULIC PUMP	FURNISH PUMP MTG PROVISIONS - INCLUDE WIRING, SWITCHES, AND INDICATORS AS REQUIRED	49	0
	183AA2	CRANKSHAFT ADAPTER	1350 SERIES FLANGE (DOES NOT INCLUDE FRONT FRAME EXTENSION)	18	-2
S	189AJ9	TRANSMISSION MOUNTED PTO	PREP KIT FOR EXTENDED SHAFT PTO	0	0
	5XXA1X	PTO TRANSMISSION MOUNTED ADM.	SINGLE PTO TRANSMISSION	0	0
S	L3XN1X	BODY BUILDER MODULE	ControlLink III BODY BUILDER EL PREP KIT, REFUSE, RP170 ELECT. INTERFACE (3 CON 54 PINS)	0	0

				WEIGHT (LB)	
SPECIALTY EQUIPMENT		DESCRIPTION		FRONT	REAR
S	8FXU1X	TRANSPORT ADAPTATION	UNIFORM LOAD NO ADAPTATION	0	0

				WEIGHT (LB)	
CAB INTERIOR (A THRU G)		DESCRIPTION		FRONT	REAR
	4AXB1X	CLIMATE UNIT	MACK INTEGRAL W/HEATER (COMBO HEATER/AIR CONIDITIONER UNIT) W/R134a REFRIGERANT	93	0
S	173063	AIR CONDITIONING/HEATER	(LR) MANUAL CONTROL CLIMATE UNIT	0	0
S	1PAZ1X	SURVEILLANCE CAMERA OPTIONS (CA)	WITHOUT CAMERA	0	0
S	31XABX	FLOOR MATS	FLOOR MAT, RUBBER	0	0
S	V8DA1X	CARBON MONOXIDE DETECTION SYS	CARBON MONOXIDE DETECTION SYSTEM	0	0
S	Z8CA1X	FUEL LEAK DETECTOR	FUEL LEAK DETECTOR, GAS	0	0
S	E0AABX	GAUGE TRANSM. OIL TEMP	TRANSMISSION GAUGE AND TRANS. OIL HIGH TEMPERATURE LIGHT	0	0
S	198048	GAUGES - UNIT OF MEASURE	U.S. UNITS (PREDOMINANT)	0	0

				WEIGHT (LB)	
CAB INTERIOR (H THRU R)		DESCRIPTION		FRONT	REAR
S	20XA1X	KEY TYPES FOR DOORS	BASIC UNIQUE KEY	0	0
S	1740D4	AUDIO ACCOMMODATION	PREMIUM STEREO, AM/FM, MP3, WEATHER BAND, BLUETOOTH	0	0
S	73AD1X	ANTENNA - RADIO	RADIO ANTENNA, CH STYLE COWL MOUNTED ON LH SIDE	0	0

TECHNICAL SPECIFICATION *(cont.)*



CAB INTERIOR (H THRU R)			DESCRIPTION	WEIGHT (LB)	
				FRONT	REAR
S	0LAA1X	AUDIO SHUTOFF	AUTO SHUTOFF FOR RADIO ENTERTAINMENT SYSTEM WHEN VEHICLE IS ENGAGED IN REVERSE	0	0
S	1WAA1X	POWER LEADS	POWER LEADS (5-WAY BINDING POSTS FOR CB RADIO) MOUNTED ON TOP OF DASH	0	0

CAB INTERIOR (S THRU Z)			DESCRIPTION	WEIGHT (LB)	
				FRONT	REAR
S	196096	SEAT - DRIVER'S	AIR-SEARS MID-BACK SEAT C-2 W/FABRIFORM CUSHIONS	0	0
	4850F0	SEAT COVERING	FABRIFORM CLOTH, BLACK, DRIVER SEATS	0	0
	5920D2	SEAT BELT(S)	LAP & SHOULDER BELTS FOR (2) DRIVER SEATS, TO BE ORANGE IN COLOR	0	0
S	2WXAA1X	STEERING WHEEL	DIAMETER 450MM STEERING WHEEL, RUBBER GRIP V1	0	0
S	XRXF1X	STEERING WHEEL ADJUSTMENT	ADJUSTABLE LH STEERING WHEEL RH FIXED	0	0
S	NPXB1X	TURN SIGNALS	SELF CANCELLING TURN SIGNALS	0	0
S	JQXAAX	WASHER RESERVOIR POSITION	W/O WINDSHIELD WASHER OPTION	0	0
S	T2AA1X	WINDSHIELD PROTECTOR	FURNISH WINDSHIELD PROTECTOR	16	0

CAB EXTERIOR			DESCRIPTION	WEIGHT (LB)	
				FRONT	REAR
S	28XD1X	FRONT GRILLE	LR BLACK GRILLE WITH BLACK SURROUND	0	0
	14400R	CAB	RH & LH SIT DOWN DRIVING POSITION, EXTENDED CAB VERSION	0	0
	424007	CAB DOOR OPTIONS	LH & RH FRONT HINGED DOORS W/POWER WINDOWS BOTH SIDES	0	0
S	2EXA1X	CAB TILT PUMP	LOCATED IN STD LOCATION	0	0
S	Q2AA1X	CAB INSTEP VERSION	Cab Low Entry Step	0	0
S	MCD01D	PASSENGER SIDE VISIBILITY OPTIONS	WITHOUT AUXILIARY WINDOW IN RH DOOR WITHOUT SIDE CLOSE VIEW MIRROR	0	0
S	154AB0	HORN - AIR	(1) TWIN-UNDER CAB TRUMPET W/DUAL LANYARD CONTROL	0	0
	LXXD1X	HORN - ELECTRICAL	DUAL TONE	0	0
S	MCL0FL	MIRRORS - LEFT SIDE EXTERIOR	LH BLACK AERO MIRROR ELECTRICAL OPERATED & HEATED, W/ HEATED SQUARE BLACK CLOSE VIEW	0	0
S	MCR0CR	MIRRORS - RIGHT SIDE EXTERIOR	RH BLACK AERO MIRROR ELECTRICAL OPERATED & HEATED, W/ HEATED SQUARE BLACK CLOSE VIEW	0	0

WHEELS & TIRES			DESCRIPTION	WEIGHT (LB)	
				FRONT	REAR
	900AW4	TIRES BRAND/TYPE - FRONT	425/65R22.5 L MICHELIN XZY3 (22800 lbs) (Total for QTY = 2)	415	0
CA	5313S1	WHEELS - FRONT	22.5x12.25 ACCURIDE BLACK POWDER COAT STEEL, 4.63" OFFSET, 5 HAND HOLE (Total for QTY = 2)	239	0
S	FWT002	FRONT AXLE TIRE & WHEEL QUANTITY	TWO FRONT TIRES & WHEELS	0	0
	901BG3	TIRES BRAND/TYPE - REAR	12R22.5 H MICHELIN XDN2 (27120 lbs) (DRIVE ONLY) (Total for QTY = 8)	0	1,182
CA	346256	WHEELS - REAR	22.5x9.00 ACCURIDE BLACK POWDER COAT STEEL, 7.00" OFFSET, 5 HAND HOLE (Total for QTY = 8)	0	865
S	RWT008	REAR AXLE TIRE & WHEEL QUANTITY	EIGHT REAR AXLE TIRES & WHEELS	0	0
S	H1EB1X	DRIVE WHEEL STUDS	DRIVE WHEEL STUDS LONGER LENGTH	0	0
S	15XABX	TIRE INFLATION VALVE	STANDARD VALVE STEMS AND CAPS	0	0

TECHNICAL SPECIFICATION *(cont.)*



				WEIGHT (LB)	
				FRONT	REAR
ENGINE ELECTRONICS		DESCRIPTION		FRONT	REAR
S	WOXA1X	OIL PRESSURE, ENGINE SHUTDOWN	OIL PRESSURE, ENGINE SHUTDOWN	0	0
S	WMXA1X	COOLANT TEMP, ENGINE SHUTDOWN	COOLANT TEMP, ENGINE SHUTDOWN	0	0
S	K5XA2X	ENGINE PROTECTION SYSTEM	ENGINE PROTECTION (SHUTDOWN)	0	0
S	X0AB0X	SMART IDLE ELEVATED IDLE RPM TIME	INCREASE 10 MINUTE MAXIMUM TIME	0	0
S	M3CA1X	IDLE S/D ABS TAMPER CHECK	IDLE SHUTDOWN ABS TAMPER CHECK, ENABLED	0	0
S	B1ACAX	IDLE S/D WARNING TIME	30 SEC IDLE S/D WARNING TIME	0	0
S	A8AALX	IDLE S/D IF WARM-UP TEMP	38C DEG (100F), WARM UP TEMP DELAY	0	0
S	A4AAEX	IDLE S/D WARM-UP TIMER	5 MIN. WARM UP TIME DELAY	0	0
S	A6AABX	IDLE S/D IF PTO ACTIVE	ENGINE IDLE SHUTDOWN TIME OVERRIDDEN IF PTO ACTIVE	0	0
S	B0AAAX	IDLE SHUTDOWN IF POWER > LIMIT	ENG IDLE SHUTDOWN TIME OVERRIDDEN IF TORQUE > THAN LIMIT	0	0
S	B3ABAX	EL HD THROTTLE,MAX ROAD SPEED	ELECTRONIC HAND THROTTLE, MAX ROAD SPEED, 16 KM/H (10 MPH)	0	0
S	B6ACEX	EL HAND THROTTLE,MAX ENG SPEED	ELECTRONIC HAND THROTTLE, MAX ENGINE SPEED, 2100 RPM	0	0
S	B4ADAX	EL HAND THROTTLE,MIN ENG SPEED	ELECTRONIC HAND THROTTLE, MIN ENGINE SPEED, 700 RPM	0	0
S	B9AABX	EL HD THROTTLE,SPEED RAMP RATE	ELECTRONIC HAND THROTTLE, SPEED RAMP RATE, 100 RPM/SEC	0	0

				WEIGHT (LB)	
				FRONT	REAR
TRANSMISSION ELECTRONICS		DESCRIPTION		FRONT	REAR
S	7790Z9	TRANSMISSION ELECTRONICS PACKAGE	GENERAL REFUSE SERVICE (168) - LIMITED TO 2ND GEAR IN SECONDARY MODE (RH DRIVING POSITION)	0	0
	B1EC1X	TRANSM AUTO NEUTRAL ON P-BRAKE	ALLISON PARK BRAKE AUTO NEUTRAL-ALLOWS THE DRIVER TO ENGAGE GEAR PRIOR TO DISENGAGING THE PARK BRAKE	0	0
S	MAV01V	TRANSMISSION ELECTRONIC SHIFTING PROPERTIES	W/O ALLISON FUELSense 2.0 PROGRAMMING	0	0

				WEIGHT (LB)	
				FRONT	REAR
VEHICLE ELECTRONICS		DESCRIPTION		FRONT	REAR
S	JCXE6X	ROAD SPEED LIMITER SETTING	105 KM/H ROAD SPEED LIMITER(65 MPH)	0	0
S	Y3CC5X	PEDAL RSL SETTING	105 KM/H PEDAL ROAD SPEED LIMITER (65MPH)	0	0
S	JDXA1X	CRUISE CONTROL	CRUISE CONTROL	0	0
S	JFXLLX	CRUISE CONTROL, MAX SPEED	MAX CRUISE, 105 KPH (65 MPH)	0	0
S	E3AACX	CRUISE CONTROL MIN SPEED	MIN CRUISE, 32 KPH (20 MPH)	0	0
S	A4BAAX	DETECTION SPEED SENSR TMRNG	DETECTION OF SPEED SENSOR TAMPERING, ENABLE	0	0
S	8RXAEX	ENG TORQUE LIMIT,SPEED SENSOR	ENG TORQUE LIMITED TO 50%, IF SPEED SENSOR TAMPER DETECTED	0	0
S	G5AAHX	ENGINE OVERSPEED,ALL COND, LOG	ENGINE OVERSPEED, ALL CONDITIONS, TIME LOG IF ABOVE 2200 RPM	0	0
S	G2AAGX	ENGINE OVERSPEED,FUELED, LOG	ENGINE OVERSPEED, FUELED, TIME LOG IF ABOVE 2100 RPM	0	0
S	G4AAUX	VEHICLE OVERSPEED,ALL COND,LOG	VEHICLE OVERSPEED,ALL COND, TIME LOG IF ABOVE 75MPH (121KMH)	0	0
S	G3AAPX	VEHICLE OVERSPEED, FUELED, LOG	VEHICLE OVERSPEED, FUELED, TIME LOG IF ABOVE 70MPH (113KMH)	0	0
S	G1AABX	ENGINE IDLE DELAY TO LOG	ENGINE IDLE DELAY TO START LOG, 2 MIN	0	0
S	W9A01X	PERIODIC TRIP LOG DAY OF MONTH	PERIODIC TRIP LOG, DAY 1 OF THE MONTH	0	0
S	X5AB1X	VEHICLE APP SERVICE INTERVALS	SERVICE INTERVALS, VOCATIONAL APPLICATION	0	0
S	W8BAAX	SERVICE ALERT	WITH SERVICE ALERT	0	0
S	W5A90X	MAINTENANCE DUE ALERT %	ACTIVATE ALERT AT 90% OF THE TIME/DISTANCE SETTING	0	0

TECHNICAL SPECIFICATION *(cont.)*



PTO ELECTRONICS			DESCRIPTION	WEIGHT (LB)	
				FRONT	REAR
S	F3AAEX	PTO1 SINGLE SPEED CONTROL RPM.	PTO 1ST, SINGLE SPEED SETTING, 1000 RPM	0	0
S	F5AABX	PTO 1ST, MAX ROAD SPEED	1ST PTO, MAX ROAD SPEED, 10 MPH (16 KPH)	0	0
S	F6AABX	PTO 1ST, SPEED RAMP RATE	PTO 1ST, SPEED RAMP RATE 100 RPM/SEC	0	0
S	F7AAPX	PTO 1ST, MAX ENGINE SPEED	PTO 1ST, MAX ENGINE SPEED, 2100 RPM	0	0
S	F8AAGX	PTO 1ST, ROAD SPEED LIMIT	PTO 1ST, ROAD SPEED LIMIT, 97 KMH (60 MPH)	0	0
S	F9AABX	PTO 1ST, MINIMUM ENGINE SPEED	PTO 1ST, MINIMUM ENGINE SPEED, 600 RPM	0	0
S	H6AAEX	PTO 2ND, SINGLE SPEED SETTING	PTO 2ND, SINGLE SPEED SETTING, 1000 RPM	0	0
S	H0AABX	PTO 2ND, MAX ROAD SPEED	2ND PTO, MAX ROAD SPEED, 10 MPH (16 KPH)	0	0
S	G9AABX	PTO 2ND, SPEED RAMP RATE	PTO 2ND, SPEED RAMP RATE 100 RPM/SEC	0	0
S	H7AANX	PTO 2ND, MAX ENGINE SPEED	PTO 2ND, MAX ENGINE SPEED, 2100 RPM	0	0
S	H5AAGX	PTO 2ND, ROAD SPEED LIMIT	PTO 2ND, ROAD SPEED LIMIT, 97 KMH (60 MPH)	0	0
S	G8AABX	PTO 2ND, MINIMUM ENGINE SPEED	PTO 2ND, MINIMUM ENGINE SPEED, 600 RPM	0	0

PAINT			DESCRIPTION	WEIGHT (LB)	
				FRONT	REAR
S	950AA4	PAINT DESIGN	SINGLE COLOR	0	0
	924024	PAINT TYPE	METALLIC PAINT	0	0
	944B16	PAINT COLOR - FIRST COLOR	BRIGHT BLUE METALLIC; P3182	0	0
S	945998	PAINT COLOR - SECOND COLOR	NO SECOND TRUCK COLOR PROVIDED; NO COLOR	0	0
S	946998	PAINT COLOR - THIRD COLOR	NO THIRD TRUCK COLOR PROVIDED; NO COLOR	0	0
S	MPB944	CAB COLOR	SAME AS FIRST COLOR - CAB	0	0
S	996AA3	PAINT - CAB PAINT SYSTEM	PAINT - CAB, URETHANE CLEAR COAT	0	0
	922001	CHASSIS RUNNING GEAR PROCESS CODE	CHASSIS PAINT PROCESS, STANDARD COLOR (MACK BLACK) 6ABZ1X	0	0
S	951AA6	CHASSIS RUNNING GEAR	MACK BLACK (URETHANE); P3036	0	0
S	958018	BUMPER	PAINT BUMPER SAME COLOR AS CHASSIS RUNNING GEAR	0	0
S	959019	FUEL TANK - ***NO INVENTED VARIANTS ALLOWED in the FUEL TANK PAINT FAMILY***	W/O OPTIONAL FUEL TANK PAINT	0	0
S	962032	HUBS & DRUMS-FRONT	SAME AS CHASSIS RUNNING GEAR	0	0
S	963033	HUBS & DRUMS-REAR	SAME AS CHASSIS RUNNING GEAR	0	0

CALCULATED CODES - KAX			DESCRIPTION	WEIGHT (LB)	
				FRONT	REAR
S	9JXA1X	PROPCALC SELECTION	YES, THE ORDER MUST BE CALCULATED	0	0
	AXXZ1X	AUX CROSSM. IN REAR OVERHANG	W/O OPTIONAL CROSSMEMBERS BEHIND REAR AXLE/BOGIE	25	-81

BASE WARRANTY & PURCHASED COVERAGES			DESCRIPTION	WEIGHT (LB)	
				FRONT	REAR
S	898003	VEHICLE WARRANTY TYPE	HEAVY DUTY WARRANTY CLASSIFICATION	0	0
S	M50030	BASIC CHASSIS COVERAGE	HEAVY DUTY STANDARD BASE COVERAGE 12 MONTHS/100,000 MILES (161,000 KM)	0	0
	M8303T	EMISSION - SURCHARGE	CARB + EPA Cummins Gas	0	0
S	M51041	ENGINE WARRANTY	CUMMINS ENGINES 8.9L (Contact Cummins for Standard Warranty and Extended Coverage Details)	0	0

TECHNICAL SPECIFICATION *(cont.)*



				WEIGHT (LB)	
				FRONT	REAR
BASE WARRANTY & PURCHASED COVERAGES		DESCRIPTION		FRONT	REAR
S	M52032	EMISSION COMPONENT COVERAGE	CUMMINS ENGINES (Contact Cummins for Standard Warranty and Extended Coverage Details)	0	0
S	M540B4	TRANSMISSION WARRANTY	ALLISON TRANSMISSIONS (Contact Allison Transmission for standard warranty and extended coverage data)	0	0
S	M550G7	CARRIER & AXLE HOUSING WARRANTY	STANDARD MACK HEAVY DUTY COVERAGE 60 MONTHS / 500,000 (804,672 KM)	0	0
S	M56026	AIR CONDITIONING WARRANTY	AIR CONDITIONING STANDARD COVERAGE (Sealed System Only) 12 MONTHS UNLIMITED MILEAGE	0	0
S	M57027	CHASSIS TOWING WARRANTY	STANDARD NORMAL / HEAVY DUTY CHASSIS TOWING 90 DAYS OR 5,000 MILES	0	0
S	M58038	ENGINE TOWING WARRANTY	CUMMINS ENGINES (Contact Cummins for Standard Warranty and Extended Coverage Details)	0	0
S	M78010	PREPAID API	WITHOUT PREPAID API	0	0

				WEIGHT (LB)	
				FRONT	REAR
ADDITIONAL OPTIONS (Requested)		DESCRIPTION		FRONT	REAR
CA	3165108	BATTERIES	(3) MACK 12V 800/2400 CCA THREADED STUD TYPE AGM LONG LIFE	0	0
CA	9443995		P3585 Bright Blue Metallic Cab Paint	0	0

				WEIGHT (LB)	
				FRONT	REAR
ADDITIONAL ENGINEERING (Requested)		DESCRIPTION		FRONT	REAR
CA	1			0	0

FRONT / REAR AXLE WEIGHTS (LB)	11442	7931
TOTAL WEIGHT (LB)	19373	

VEHICLE SPECIFICATION/CALCULATED PERFORMANCE SUMMARY

Description	Sales Code	Dwg Ref	Length	UOM
Front Frame Extension	N/A	FE	0.0	INCHES
Bumper to Front Axle	N/A	BA	69.9	INCHES
Wheelbase	N/A	WB	210.0	INCHES
Rear Overhang	N/A	OH	66.9	INCHES
Overall Length	N/A	OL	346.9	INCHES
Bumper to Back of Cab	N/A	BBC	64.6	INCHES
Eff. Bumper to Back of Cab	N/A	EBBC	94.6	INCHES
Eff. Cab to Rear Axle	N/A	ECA	185.3	INCHES
Eff. Front Axle to Back of Cab	N/A	EAC	24.7	INCHES
Eff. Cab to End of Frame	N/A	ECEF	252.2	INCHES
Unladen 5th Wheel Height	AAX29X	5W	0.0	INCHES
Unladen Frame Height	N/A	FH	43.9	INCHES
Cab Height	N/A	CH	56.1	INCHES
Overall Height	N/A	OVH	100.0	INCHES
Driver CG	N/A	DCG	13.8	INCHES
50" AXLE SPACING (BOGIE WHEELBASE)	GWXABX	BS	50.0	INCHES
Second Front Axle Spacing		SFAS	0.0	INCHES

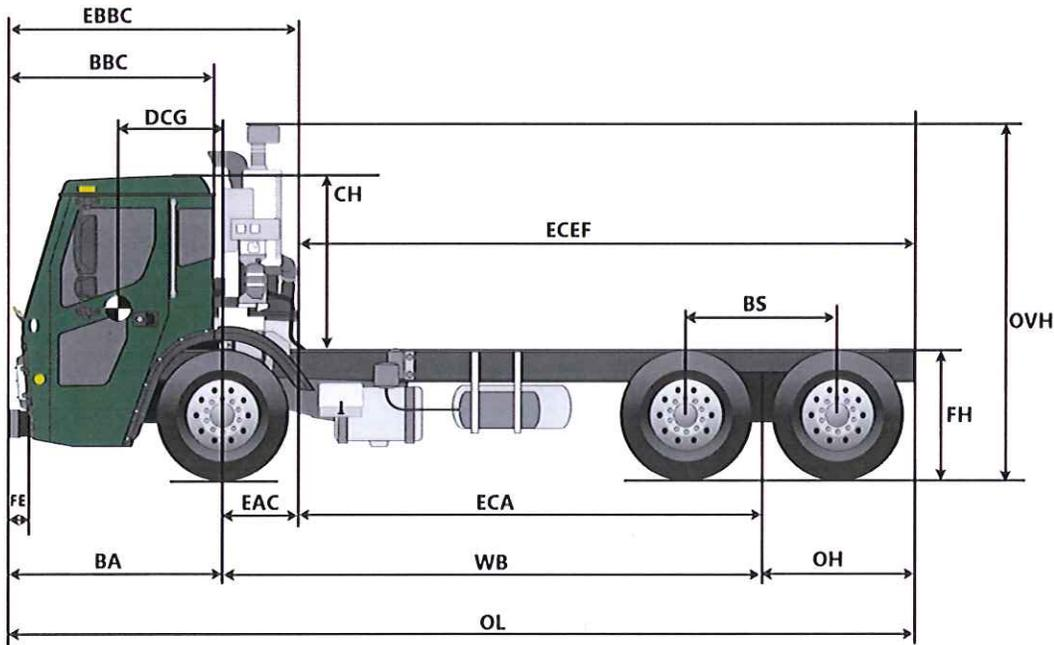



This specification contains options which affect the accuracy of Top View and its calculations. An Image is NOT available due to the following selections:
6WAC1X

VEHICLE SPECIFICATION/CALCULATED PERFORMANCE SUMMARY

Description	Sales Code	Dwg Ref	Rear		UOM
			Unladen	Laden	
Requested Fifth Wheel Height	AAX29X		0.0	0.0	INCHES
Tire Radius	901BG3	A	21.5	20.0	INCHES
Suspension Height	1860K6	B	11.7	8.7	INCHES
Frame Depth	YBXJ1X	C	10.8	10.8	INCHES
Closest Available Fifth Wheel Leg Height	N/A	D	0.0	0.0	INCHES
Total Height	N/A	E	43.9	39.4	INCHES

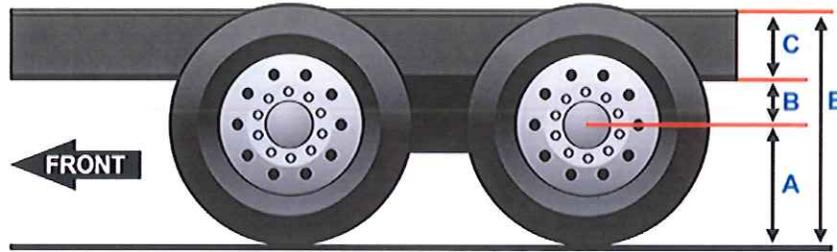

VEHICLE SPECIFICATION/CALCULATED PERFORMANCE SUMMARY

Description	Sales Code	Dwg Ref	Length	UOM
SAE Turning Radius	N/A	A*	36.6	FEET
Adjusted Turning Radius	N/A	A	40.6	FEET
Curb-to-Curb Diameter	N/A	B	82.5	FEET
Wall-to-Wall Diameter	N/A	C	93.1	FEET

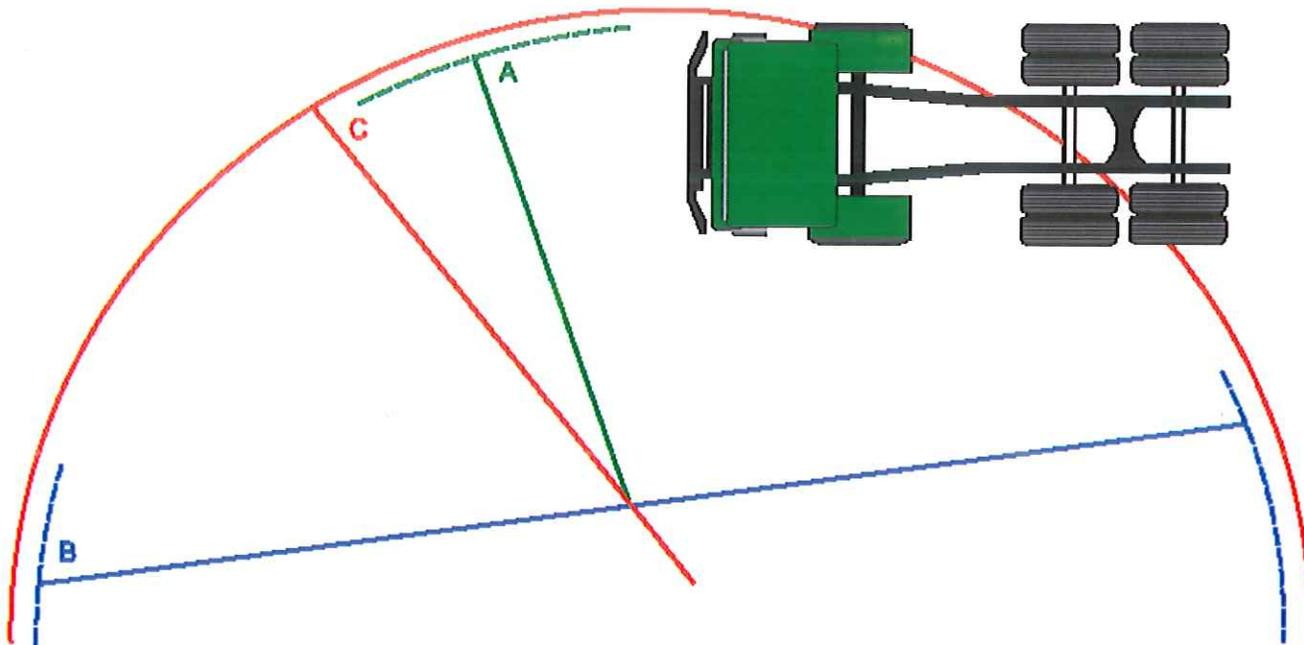

Tests have shown that the true location of the turning center is further to the rear than midway between drive axle sets (where applicable)

The actual location of the turning center depends on:

- Whether the drive tire equipment is single or dual.
- The overall load distribution for the vehicle (front/rear, between drive axles) in a loaded condition
- Manufacturing tolerances within the steering components



Inputs Required	Inputs	UOM
Driver Weight	201	LB
Total Body Length	16.4	FEET
Body Tare Weight	3501	LB
Front of Body to Body CG	96.0	INCHES
Additional Clearance from Back of Exhaust to Front of Body	6.0	INCHES

VEHICLE SPECIFICATION SUMMARY				
Description	Description	Dwg Ref	Length	UOM
Bumper to Front Axle	N/A	BA	69.9	INCHES
Wheelbase	N/A	WB	210.0	INCHES
Rear Overhang	N/A	OH	66.9	INCHES
Bumper to Back of Cab	N/A	BBC	64.6	INCHES
BOC Exhaust Space	DPFAB3	N/A	30.0	INCHES
Driver CG from Front Axle	N/A	DCG	13.8	INCHES
First Pusher Axle Spacing			0.0	INCHES

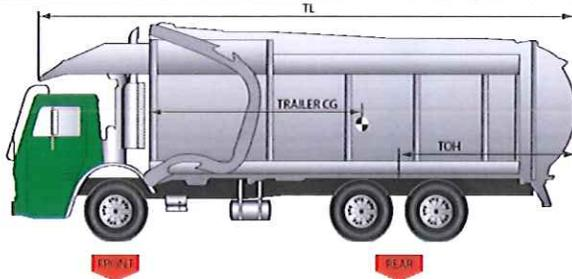

CALCULATED PERFORMANCE SUMMARY				
Tare Weights	Front Axle	Rear Axle (s)	Total	UOM
Chassis	11442	7931	19373	LB
Driver	188	14	201	LB
Fuel	0	0	0	LB
Body/Trailer	1388	2114	3501	LB
Total Tare	13018	10057	23074	LB
Payloads				
First Body Payload	17018	25909	42927	LB
Total - Lift Axles Down	30036	35965	66000	LB
GAWR	20000	46001	66000	LB



VEHICLE SPECIFICATION/CALCULATED PERFORMANCE SUMMARY

Sub-Category	Sales Code	Sales Code Description	Value	UOM	
Front Axle	240AA3	20000# (9100 KG) MACK FXL20 WIDE PIVOT CENTER STRAIGHT SPINDLE/UNITIZED BEARINGS	20000	LB	
Front Suspension	244AB4	MACK TAPERLEAF 20000# (9100 KG) GROUND LOAD RATING, EQUAL BIAS	20000	LB	
Front Tires	900AW4	425/65R22.5 L MICHELIN XZY3 (22800 lbs)	22801	LB	
Front Wheels	5313S1	22.5x12.25 ACCURIDE BLACK POWDER COAT STEEL, 4.63" OFFSET, 5 HAND HOLE	22995	LB	
			Front GAWR	20000	LB
Rear Axle	268AA9	46000# (20900kg) MACK S462R CAST DUCTILE HOUSING	46001	LB	
Rear Suspension	1860K6	SS46 MACK CAMELBACK MULTILEAF 46,000 lb, HEAVY DUTY	46001	LB	
Rear Tires	901BG3	12R22.5 H MICHELIN XDN2 (27120 lbs) (DRIVE ONLY)	54241	LB	
Rear Wheels	346256	22.5x9.00 ACCURIDE BLACK POWDER COAT STEEL, 7.00" OFFSET, 5 HAND HOLE	80002	LB	
			Rear GAWR	46001	LB
			Truck GVWR	66000	LB
			Gross Combination Weight Rating	0	LB
			Tax Value GVWR (USA FET Only)	66000	LB



Mack Trucks
www.macktrucks.com

Extended Coverage: CWI L9N and B6.7N Protection Plan I

Available on 2018 Cummins Westport L9N and B6.7N engines in the United States, Canada and Mexico.

Protection Plan I includes:

- Registered parts and labor;
- Covers Internal components and major engine systems;
- Covers all these components, including listed parts below and their mounting hardware and gaskets:
 - Cylinder head assembly
 - Cylinder block assembly
 - Rocker lever assembly
 - ECM
 - Piston, rings, and liners
 - Lube oil cooler assembly
 - Front gear cover assembly
 - Oil pan assembly
 - Connecting rod assembly
 - Lube Pump assembly
 - Camshaft assembly and bushings
 - Cam follower assemblies
 - Crank shaft assemblies
 - EGR cooler, valve and mixer
 - Turbo assembly
 - Water pump
 - Brake assembly
 - Air Compressor assembly
 - Select engine sensors
 - Low fuel pressure regulator
 - Throttle Plate Actuator
 - Closed Crankcase Ventilation (CCV) system *New for 2018

Protection Plan I - L9N

Years	Miles	Customer \$
3	100,000	\$1100
3	150,000	\$1600
4	150,000	\$1850
4	200,000	\$2850
5	150,000	\$2400
5	200,000	\$3100

Years	Miles	Customer \$
5	250,000	\$4100
5	300,000	\$5600
<i>Program ID</i>		GE1
<i>MATRIX</i>		334195

Protection Plan I - B6.7N

Years	Miles	Customer \$
3	100,000	\$900
3	150,000	\$1300
4	150,000	\$1500
4	200,000	\$2300
5	150,000	\$1950
5	200,000	\$2500
5	250,000	\$3300
5	300,000	\$4500
<i>Program ID</i>		GE1
<i>MATRIX</i>		334196

PHONE: 502-584-3524

FAX: 502-584-7067

J. EDINGER & SON, INC.
1010 STORY AVENUE
LOUISVILLE, KY 40206
EST. 1867

December 13, 2021

Jim Dotson
Worldwide Equipment
Jim.Dotson@theTruckPeople.com
RE: Lexington Fayette Urban Co Govt
125-2021 CNG Front Loaders

Jim,

Our bid price for renewing the 40 yard E-Z Pack Hercules Front Loaders with CNG package and related equipment is \$179,186.00 per unit exclusive of any taxes. The cost is FOB Cynthiana. The delivery is approximately 60-90 days after receipt of chassis. Per agreement we will be paid the next business day after Worldwide has been paid whether that is for one or more units. There are no exceptions

The chassis dealer is responsible for the methane detector, safety triangle kit and supplying a suitable chassis with proper CT dimension and clear frame to facilitate mounting without additional time and costs for factory installation. A detailed frame layout should be supplied to E-Z Pack if an order is placed.

Cost assumes chassis available for install in third or fourth quarter of 2022. Literature and other material are being sent under a separate email.

Thank you for the opportunity to quote. We hope we may be favored by your order

Charlie Edinger



EZ Pack Refuse Hauling Solutions, 200 Ladish Road, Cynthiana, KY 41031

Manufacturer's Warranty

EZ Pack Refuse Bodies

TO ESTABLISH YOUR WARRANTY, PLEASE FILL OUT THE ATTACHED WARRANTY REGISTRATION CARD AND MAIL WITHIN 2 WEEKS OF DATE UNIT IS PLACED INTO SERVICE TO: EZ PACK REFUSE HAULING SOLUTIONS, 200 LADISH ROAD, CYNTHIANA, KY 41031.

EZ Pack, referred to herein as the Manufacturer, warrants each new product of it's own manufacture to be free from defects in material and workmanship, under normal use and service, to the original user only, for a period of 12 months Body and 60 months Cylinders from date of purchase, subject to conditions outlined below. Manufacturer's obligation under this warranty is limited to repair, or replacement with a similar part, any part of the product of our manufacture which is returned to us within 30 days after discovery of the defect, properly identified and transportation charges prepaid, and not more than 12 months after purchase by the original user, provided that in Manufacturer's judgment the part is defective in material or workmanship.

Manufacturer will furnish without charge FOB it's plant a similar part to replace any part of a product of it's manufacture which proves to be defective in material or workmanship while in normal use and service during this period.

The Manufacturer's warranty or obligation in connection with the sale of the product:

1. Shall be expressly limited to the repair or replacement of defective parts, as stated above, all other damage and claims, statutory or otherwise, being hereby expressly waived by the purchaser and covers only those labor charges specifically authorized by Manufacturer.
2. Shall not apply if the product has been operated beyond the Manufacturer's recommended capacity.
3. Shall not apply to any failure or damage incurred through neglect, lack of maintenance, misuse, accident, improper installation, reconstructing or modifying of assemblies or through any other cause beyond the control of the Manufacturer.
4. Does not cover products of other manufacturer beyond such warranty as is made by such manufacturer.

No claim under this warranty shall be valid unless such claim is submitted within twelve (12) months after date of sale or within thirty (30) days after discovery of the defect which is the basis for such claim, whichever event shall occur first.

THE FOREGOING IS MANUFACTURER'S SOLE WARRANTY AND MANUFACTURER MAKES NO OTHER WARRANTIES OF ANY KIND WHATSOEVER, EXPRESS, IMPLIED OR STATUTORY AND ALL IMPLIED WARRANTIES OF MERCHANTABILITY AND FITNESS FOR A PARTICULAR PURPOSE, WRITTEN OR ORAL ARE HEREBY DISCLAIMED BY THE MANUFACTURER.

IN NO EVENT SHALL EZ PACK BE LIABLE FOR CONSEQUENTIAL DAMAGES, NOR SHALL EZ PACK'S LIABILITY ON ANY CLAIM FOR ANY DIRECT INCIDENTAL OR SPECIAL DAMAGES ARISING OUT OF OR CONNECTED WITH THE SALES CONTRACT OR MANUFACTURE, SALE, DELIVERY, OR USE OF THE PRODUCTS EXCEED THE PURCHASE PRICE OF THE GOODS.

**DISTRIBUTOR MUST OBTAIN FACTORY AUTHORIZATION
BEFORE MAKING WARRANTY REPAIRS OR REPLACEMENT**



Refuse Hauling Solutions, LLC

**2022 Hercules Front Loader
Product Information**

BUILT E-Z PACK STRONG



For over 60 years E-Z Pack has been the industry leader in mobile refuse collection vehicle designs and specializes refuse body manufacturing. E-Z Packs reputation is noted for its high quality, durability, easy to use operator controls, giving you the lowest cost of ownership in the industry.

The following for your review is detailed information on the HERCULES Commercial Front Loader design and manufacturing process. Plus information on optional equipment to customize your equipment to your needs.

HERCULES Product Overview



BUILT E-Z PACK STRONG!



HERCULES Body Highlights

The legendary E-Z Pack HERCULES offers unique design features that are unmatched in the industry. Compare for yourself and you will see why the HERCULES is the best buy in the business.



- 1) Industry's Largest Hopper Opening 101"
- 2) Radius Body Sides, Roof and Floor
- 3) Automatic Locking Tailgate with Safety Pins
- 4) Factory Applied body Undercoating
- 5) 10,000 Lbs Bolt-on Lift Arms
- 6) Heavy Duty Packer Cylinder Bulk Head
- 7) 60" Low Profile Forks with 6" Bumper Spacers
- 8) Premium Body Paint and Undercoating

BUILT E-Z PACK STRONG!



2019 HERCULES HYDRAULIC RESERVIOR

The newly designed hydraulic reservoir includes an integrated return line hydraulic filter that allows for easy filter replacement and additional frame clearance when installing auxiliary axles.

Plus a 12" Sight and Temperature gauge allows for fluid level checks at any position of the hydraulic cylinders.

Additional accessory ports have also been added to accommodate filter buggy connections and or hydraulic heaters.

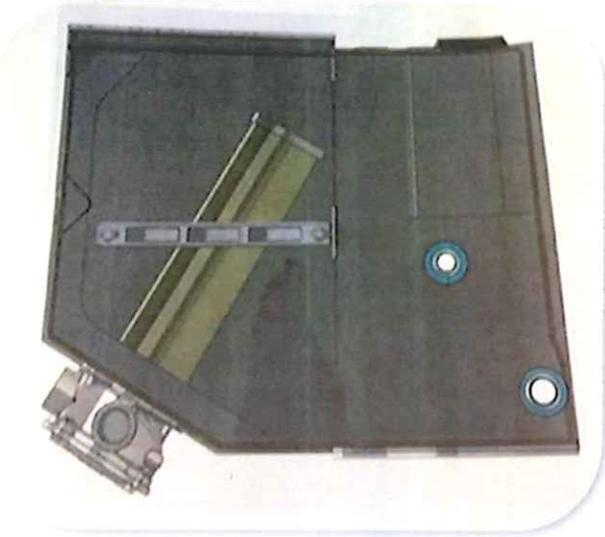

BUILT E-Z PACK STRONG!



E-Z Packs interlaced design is where the long members are cut out so that the cross members are recessed to give full support vs a stacked floor support that gives way to wash boarding.

An additional cross member support is also added in the E-Z Pack design for additional support.

The HERCULES heavy duty hopper understructure is a interlaced design that will give you years of trouble free service.



BUILT E-Z PACK STRONG!



The HERCULES front loader includes integrated operator controls for most Autocar, Mack and Peterbilt Chassis.



BUILT E-Z PACK STRONG!

HERCULES Steel Specifications

E-Z Pack products are built with high quality engineered grade steel for the refuse application. We call this **SMART STEEL**.

E-Z Pack's **SMART STEEL** metal goes through a slightly different quenching and tempering process than standard off the shelf AR steel, which gives it a tough and wear-resistant exterior while eliminating all brittleness within the core of the steel.



Description	Gauge	Grade
Hopper Floor	1/4"	AR 155,000 PSI Single Plate
Hopper Long Sill	7 Ga.	100,000 PSI Smart Steel Form Channel
Hopper Long Sill Crossmember	3/16"	4" x 3" Steel Tube
Hopper Crossmember Support	7 Ga.	8" Long Sleeve
Hopper Transition Crossmember	1/4"	6" x 4" Steel Tube
Hopper Lower Side Walls	3/16"	100,000 PSI Smart Steel
Hopper Lower Side Wall Liner	10 Ga.	100,000 PSI Smart Steel 22" High
Hopper Upper Hopper Side Walls	10 Ga.	100,000 PSI Smart Steel
Cab Guard	12 Ga.	50,000 PSI Smart Steel
Body Roof	10 Ga.	100,000 PSI Smart Steel - Radius
Body Side Walls	7 Ga.	100,000 PSI Smart Steel - Radius
Body Floor	7 Ga.	100,000 PSI Smart Steel - Radius
Roof Superstructure	7 Ga.	100,000 PSI Smart Steel 2 1/4" x 8 3/8" Formed Channel
Roof Superstructure	3/16"	3" x 2" Steel Tube
Body Floor Structure	7 Ga.	100,000 PSI Smart Steel "V" Channel
Body Floor Rear Bolster	1/4"	100,000 PSI Smart Steel Formed Channel
Lift Arm Support Bar	3/4"	3" 80,000 PSI Smart Steel - Bar
Lift Arm Side Plates	1/4"	100,000 PSI Smart Steel - Plate
Lift Arm Cylinder Anchor Plates	1/2"	50,000 PSI Smart Steel - Plate
Fork Tangs 60"	1"	T-1 Steel Plate
Fork Torque Tube	3/4"	Seamless Steel Tubing 3 1/2" O.D.
Packer Panel Super Structure	1/4"	100,000 PSI 3" x 3" Steel Tube
Packer Panel Lower Face Plate	1/4"	100,000 PSI Smart Steel - Plate
Packer Panel Slope Face Plate	7 Ga.	100,000 PSI Smart Steel - Plate
Packer Panel Upper Face Plate	10 Ga.	100,000 PSI Smart Steel - Plate
Packer Panel Guide Channels	3/8"	AR500 180,000 PSI 3" Wide Wear Plate
Packer Panel Center Wear Tracks	3/8"	AR500 180,000 PSI 6" Wide Wear Plate
Tailgate Walls	10 Ga.	100,000 PSI Smart Steel
Tailgate Braces	7 Ga.	100,000 PSI Smart Steel
Tailgate Hinges	1/2"	100,000 PSI Smart Steel - Plate

Premium Design and Hydraulic Components

From line sizes to the large hydraulic filters, the E-Z Pack Hercules sets the industry standard by offering a premium hydraulic system.

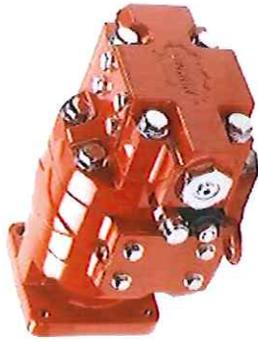

HYDRAULIC PUMP -

At the heart of the Hercules hydraulic system is the Perenco hydraulic pump. The Perenco pump is cast iron and flow regulated, offering a "No Kick Out" feature when dumping containers and allows the operator to "Pack on the Run" with no pump damage or overheating.

HYDRAULIC FILTRATION - Some manufacturers talk about the small micron hydraulic filters as a fix all, but the Hercules offers the largest return line filter with "In-Cab Service Indicators" for extended hydraulic service.



HIGH QUALITY HYDRAULIC CYLINDERS - E-Z Pack is equipped with premium hydraulic cylinders just for the waste industry, giving you years of trouble free service.



RUSTPROOF HYDRAULIC LINES - The Hercules hydraulic system offers maximum line sizes throughout the system allowing less restriction and faster fluid cooling. Plus all steel lines are made from "Rust Proof" steel and are held in place with high quality clamps for a long service life.



E-Z PACK STRONG!

The E-Z Pack HERCULES front loader is equipped with premium industry leading, packer cylinders designed specifically to withstand the severe environment of waste removal application.

The HERCULES front loader packer cylinders offers the following features:

- ✓ Stainless Steel – Scraper Wiper Rings
- ✓ Nitriding surface-hardening treatment (No Chrome)
- ✓ High-Duty Cycle Design
- ✓ Self Aligning Cylinder Bearings
- ✓ Simplified design: 50% less components



BUILT E-Z PACK STRONG!



E-Z Pack Paint and Undercoating

E-Z Pack knows that their products lives a hard life and that is one of the reasons that E-Z Pack uses a high quality industrial grade primer and body paint.



Step 1. The superstructure and components are cleaned, deburred of weld splatter and slag.

Step 2. The superstructure and components are shot blasted for a clean surface. Then the components are washed with a chemical for paint prep.

Step 3. A high quality primer is applied then a heavy duty coating is applied.

Step 4. The superstructure and components are cured in the bake booth for a high quality finish.

Step 5. Once the paint has cured a industrial grade undercoating is then applied for extra protection.





HERCULES COMMERCIAL FRONT LOADER

Model FLO080J40SE

FL Front Loader

OO Commercial Grade Body

10 10,000 Lift Capacity

J Model Lift Arm

40 40 Cubic Yard Capacity

S Sliding Top Door

E Full Ejection Style

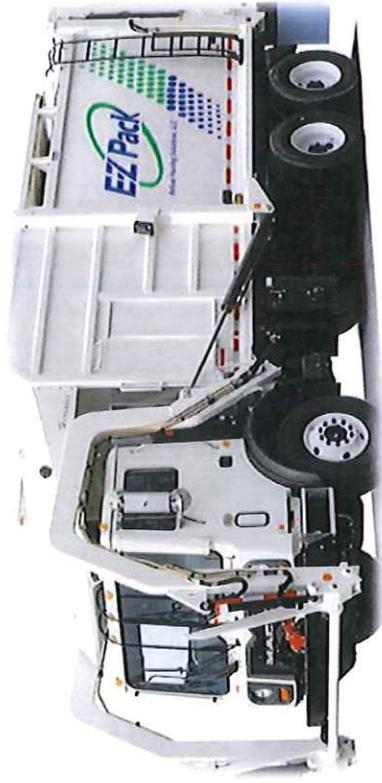

Model Year	2022	Order Code	CFL-40
Description	Hercules 40 Cubic Yard Front Loader		

Standard Equipment includes the following:

- ✓ Commercial Grade Superstructure Assembly
- ✓ Bolt-on Lift Arms – 10,000 Lbs Construction
- ✓ Heavy Duty Tailgate with Auto Latch and Safety Prop
- ✓ SMART STEEL Radiuses Body Floor, Side and Roof
- ✓ 100 Gallon Body Sump for Liquid Retention
- ✓ Bolt on Cab Shield
- ✓ Sliding Hopper Cover
- ✓ Large Body Access Door with Safety Grab Handles
- ✓ 8" Convex Mirror – Driver Side
- ✓ Commercial Grade Hydraulic Package
- ✓ Premium Packer Cylinders
- ✓ E-Z Pack Prox. Control Switches
- ✓ Premium Paint White with Body Undercoating
- ✓ DOT Approved Reflective Tape
- ✓ MVSS108 Compliant Lights with LED Light
- ✓ High Mount Tailgate Lights with Center Brake Light
- ✓ Factory Made Wiring Harness
- ✓ ANSI Approved Top Body Tie Off Containment
- ✓ ANSI Approved Top Body Access Ladder
- ✓ Full Factory Mount
- ✓ Hopper Sump Overlay
- ✓ Integrated Operator Controls
- ✓ Operator In Cab Air Control – Forks / Arm
- ✓ Auto Pack – Packer Controls
- ✓ Packer Panel Remote Lube Lines
- ✓ 6" Wide AR Center Wear Shoes and Tracks

EZ Pack Refuse Hauling Solutions, LLC, reserves the right under its Product Improvement Program to modify construction and/or design and furnish equipment without reference to illustrations and specifications shown herein. All specifications are subject to change without notice.



Option includes the following:
(4) 4" Heavy Duty Weld-in Sharks Teeth installed on the upper section of the packer panel.

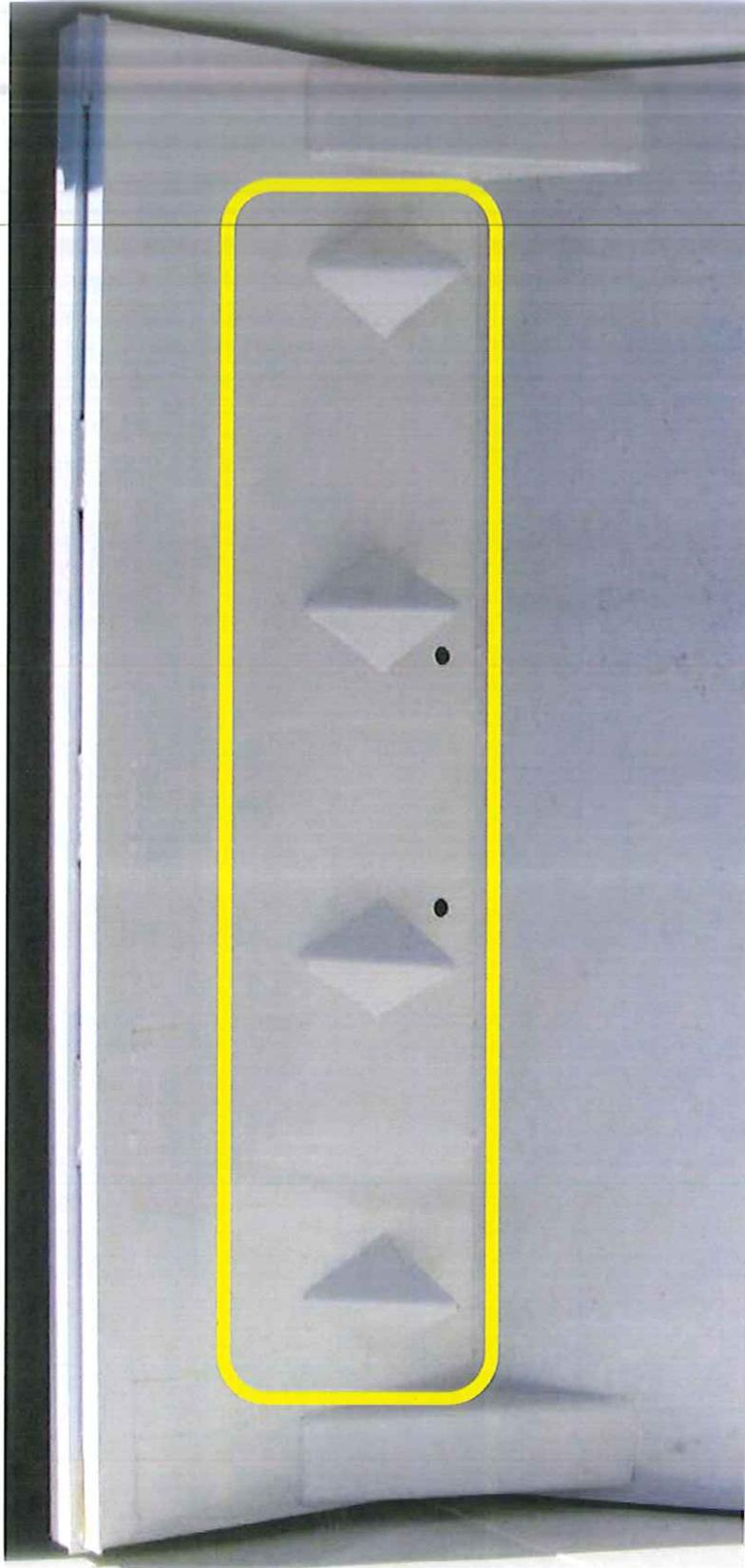

Model Year	2019	Order Code	FB6
Description	(4) 4" Sharks Teeth - Packer Blade		

E-Z Pack Refuse Hauling Solutions, LLC, reserves the right under its Product Improvement Program to modify construction and/or design and furnish equipment without reference to illustrations and specifications shown herein. All specifications are subject to change without notice.



Option includes the following:
 The Body / Hopper access ladder provides a easy and safe manor for the operator to access the body hopper. Bolt-on Design

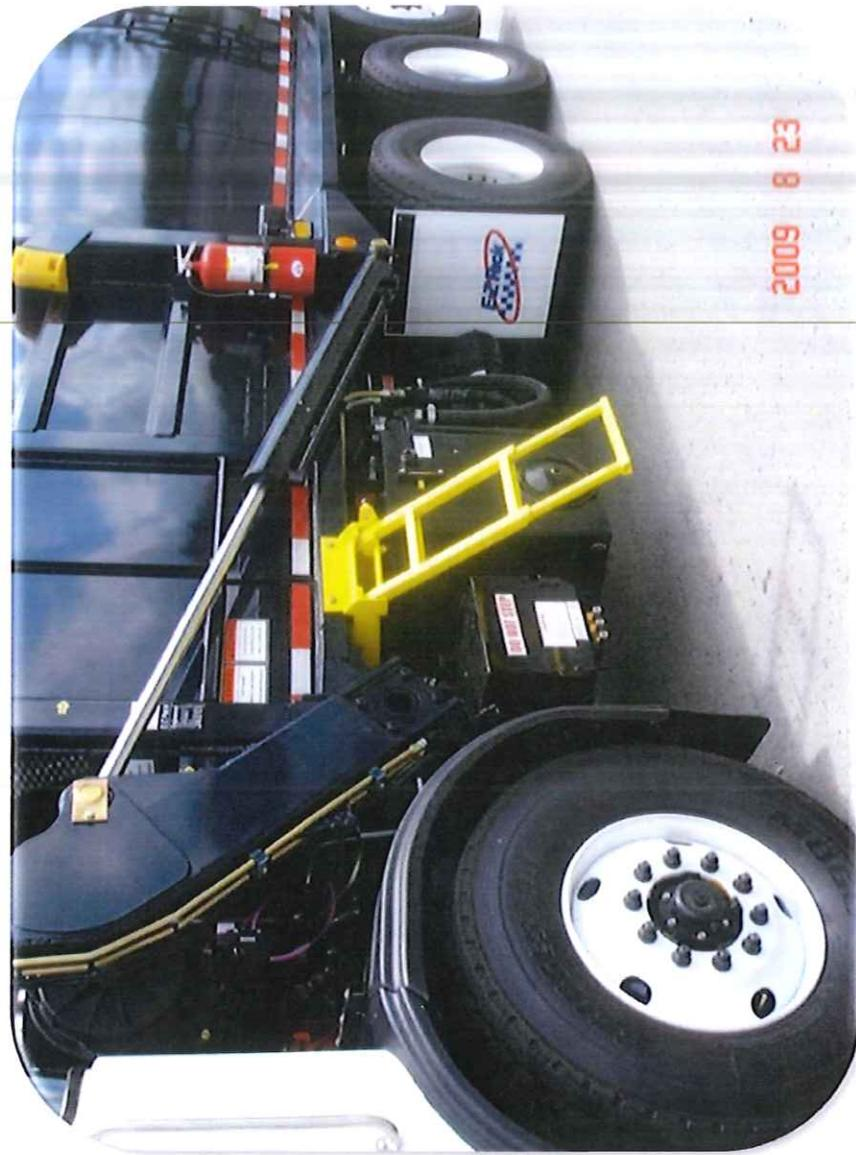

Model Year	2019	Order Code	FB9
Description	Under Body Ladder - Hopper Access		

E-Z Pack Refuse Hauling Solutions, LLC, reserves the right under its Product Improvement Program to modify construction and/or design and furnish equipment without reference to illustrations and specifications shown herein. All specifications are subject to change without notice.



Option includes the following:
Heavy Duty expanded metal to cover the body front bulk head. –
Weld -in



Model Year	2019	Order Code	FB11
Description	Front Body Screen Enclosure -Weld		

EZ Pack Refuse Hauling Solutions, LLC, reserves the right, under its Product Improvement Program to modify construction and/or design and furnish equipment without reference to illustrations and specifications shown herein. All specifications are subject to change without notice.



Bolt-in Design
Paint Black

BUILT E-Z PACK STRONG!



Description: This new cab shield is radius so that any debris that falls out of the container when dumping will roll-off so that the operator will not need to climb on top the truck to remove the debris.

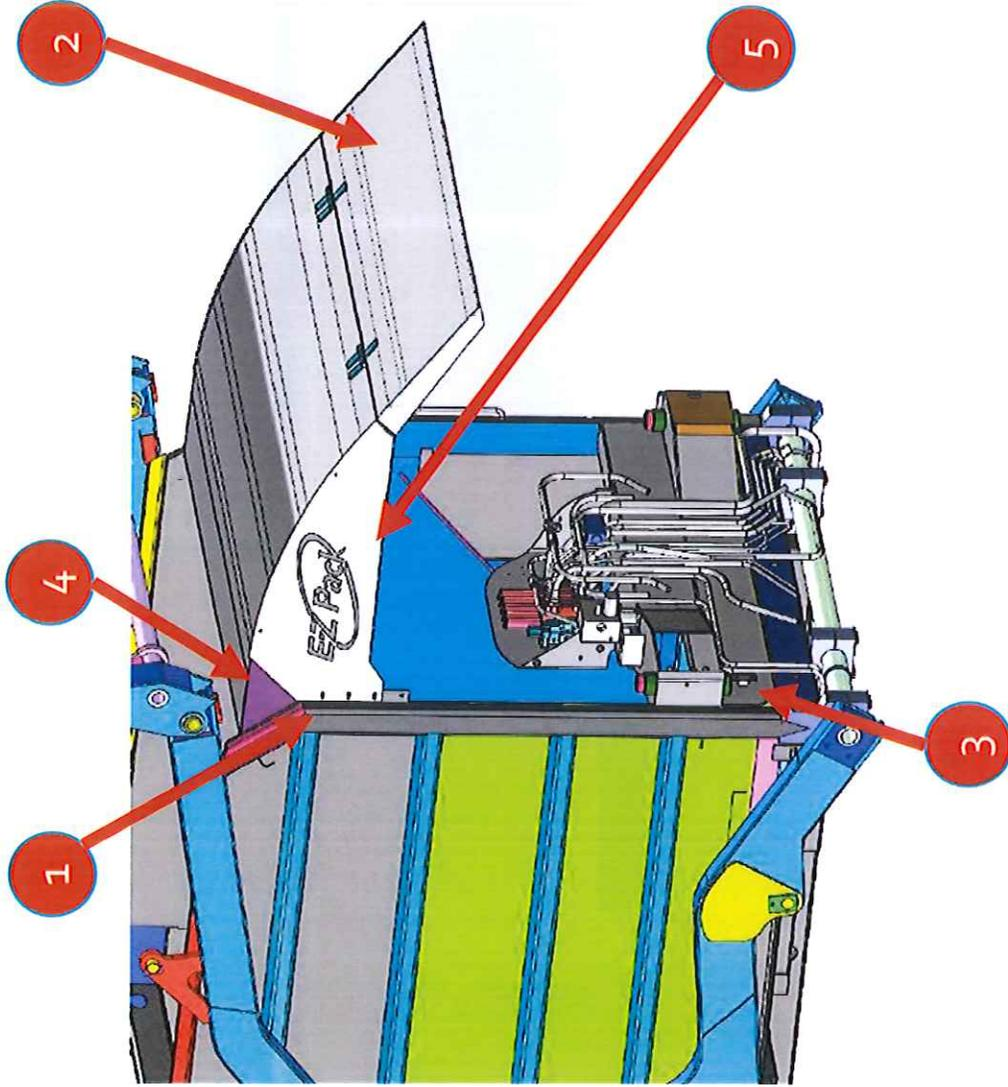

This option includes the following:

- 1) New bolt-on Radius Cab Shield
- 2) Pneumatic Extension
- 3) Operator Valve with Fork/Arm Interlock
- 4) Side Exhaust Ports
- 5) Raised Side Walls Side Exhaust

Model Year	2017	Order Code	FB14
Description	Radius Canopy with Air Flip Ext.		

E-Z Pack Refuse Hauling Solutions, LLC, reserves the right under its Product Improvement Program to modify construction and/or design and furnish equipment without reference to illustrations and specifications shown herein. All specifications are subject to change without notice.



CleanShield is a multi-layered sandwich of films and adhesives designed to be easily applied, long lasting and most of all impervious to even the most corrosive mixture of environmental and waste related pollutants. CleanShield can handle just about any pollutant you can throw at or on it!

Canopy and Cab Protection Liner

Finally, a Way to Keep Cabs & Cab Shields Clean, Guaranteed!

**CleanShield® and CleanCab®
Protect Your Brand From:**

- Environmental Pollutants
- Diesel Fuel
- Paint Spills
- Chemical Spills
- UV Degradation
- Leachate



E-Z Pack Refuse Hauling Solutions, LLC, reserves the right under its Product Improvement Program to modify construction and/or design and furnish equipment without reference to illustrations and specifications shown herein. All specifications are subject to change without notice.



Option includes the following:

- Factory Installed
- (1) 24" H x 72" W Caution Sign - Reflective



Model Year	2019	Order Code	FB26
Description	CAUTION Sign - Reflective		

E-Z Pack Refuse Hauling Solutions, LLC, reserves the right under its Product Improvement Program to modify construction and/or design and furnish equipment without reference to illustrations and specifications shown herein. All specifications are subject to change without notice.



Option includes the following:

- 4" Rubber housing flood light mounted on the main control valve mounting bracket pointed into the body hopper.
- Switched from in cab located on the packer control box

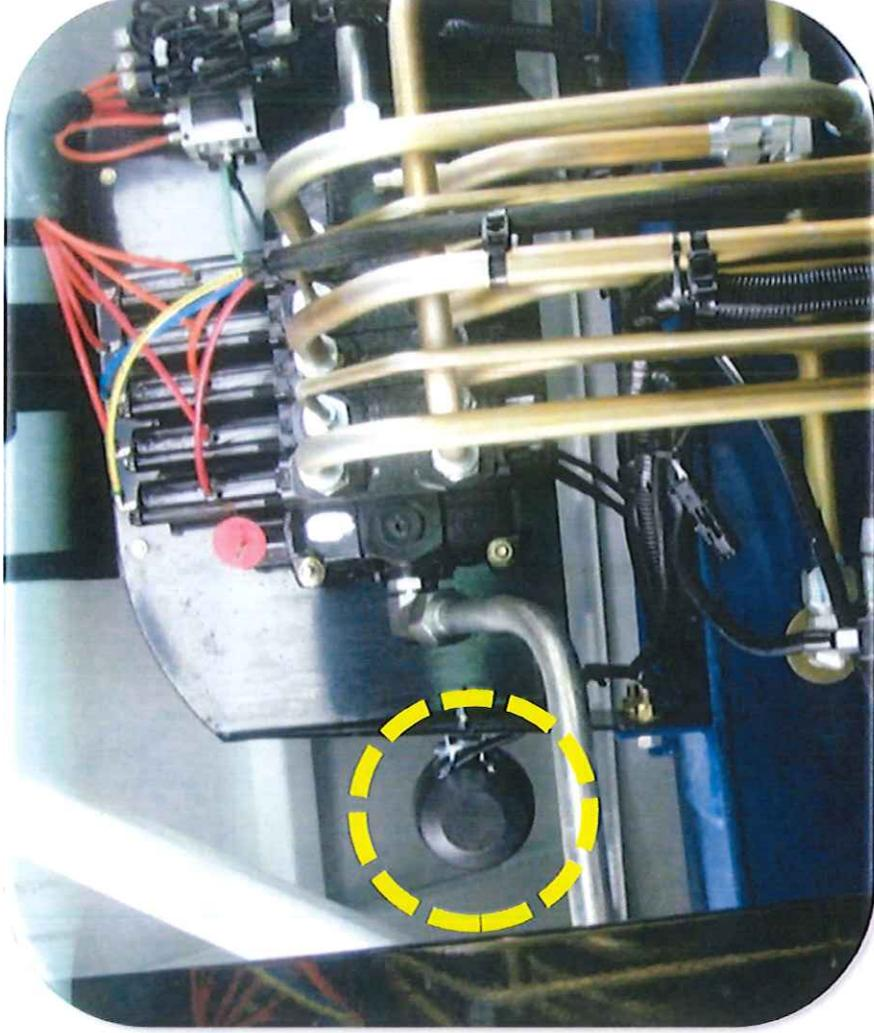

Model Year	2017	Order Code	FE1
Description	Hopper Flood Light		

EZ Pack Refuse Hauling Solutions, LLC, reserves the right under its Product Improvement Program to modify construction and/or design and furnish equipment without reference to illustrations and specifications shown herein. All specifications are subject to change without notice.



Option includes the following:

- (1) Container Flood Light
- Mounted on Chassis Mirror
- Switch In Cab
- Additional locations available on request.

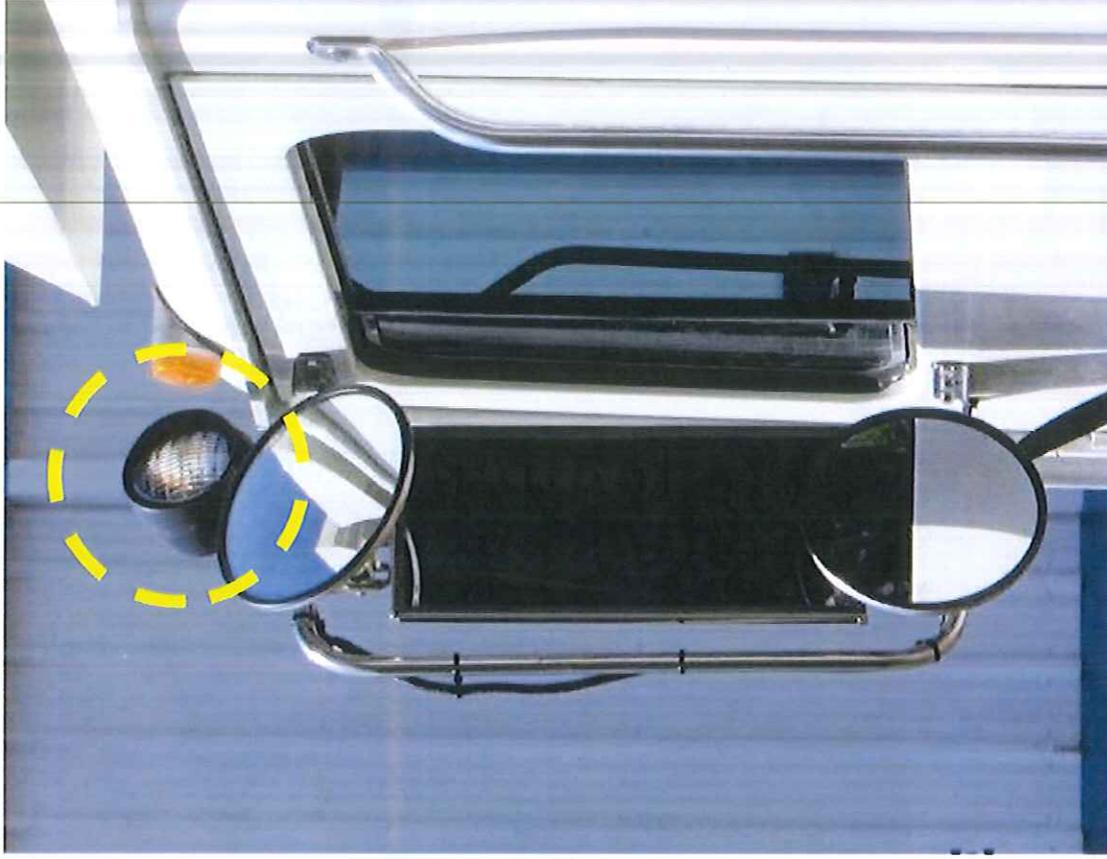

Model Year	2017	Order Code	FE3
Description	Container Work Light - LED		

E-Z Pack Refuse Hauling Solutions, LLC, reserves the right under its Product Improvement Program to modify construction and/or design and furnish equipment without reference to illustrations and specifications shown herein. All specifications are subject to change without notice.



Option includes the following:

- (4) Amber LED lights replace red turn signals

- ✓ Lights function as both alternating strobes and rear turn signals.
- ✓ Fits standard mounting grommet for 4" diameter lights.
- ✓ Triple-flash strobe function meets SAE J845 Class 2 specification.
- ✓ Turn signal function meets DOT rear turn specification.
- ✓ Can be wired so that shifting into reverse automatically activates strobe function.
- ✓ Activating turn signal automatically overrides strobe function.
- ✓ Two power wires allow strobes to be activated two ways, i.e. with cab switch and automatically when shifted into reverse.



Model Year	2019	Order Code	FE7
Description	Peterson Smart Strobes (4)		

E-Z Pack Refuse Hauling Solutions, LLC, reserves the right under its Product Improvement Program to modify construction and/or design and furnish equipment without reference to illustrations and specifications shown herein. All specifications are subject to change without notice.



Option includes the following:

- Dual Camera System

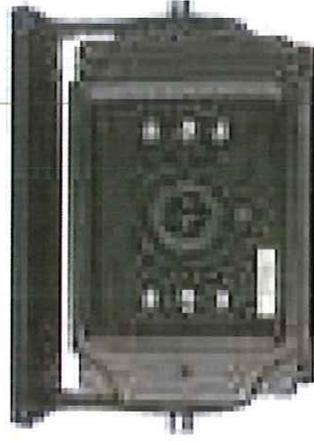

Back up Camera

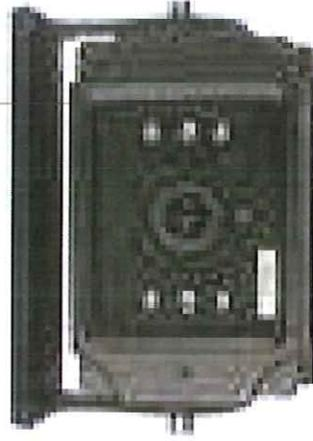

Hopper View

Model Year	2019	Order Code	FV7
Description	Dual Camera System		

E-Z Pack Refuse Hauling Solutions, LLC, reserves the right under its Product Improvement Program to modify construction and/or design and furnish equipment without reference to illustrations and specifications shown herein. All specifications are subject to change without notice.



First Year Hydraulic Service Kit – Body Only Front Loader

The first year of operation, the front loader the hydraulic system is required that the return line and reservoir breather filters to be replaced after the first 30 days of operation. Then replace the hydraulic filter and breathers every 6 months.

This first year hydraulic service kit includes the following:

- (2) Return Line Filter
- (2) O-rings
- (6) Breather Filters.

Model Year	2018	Order Code	2122212
Description	1st Year Hydraulic Kit CFL		

E-Z Pack Refuse Hauling Solutions, LLC, reserves the right under its Product Improvement Program to modify construction and/or design and furnish equipment without reference to illustrations and specifications shown herein. All specifications are subject to change without notice.

350,000 SQ. FT of sparks, steel, and hard work

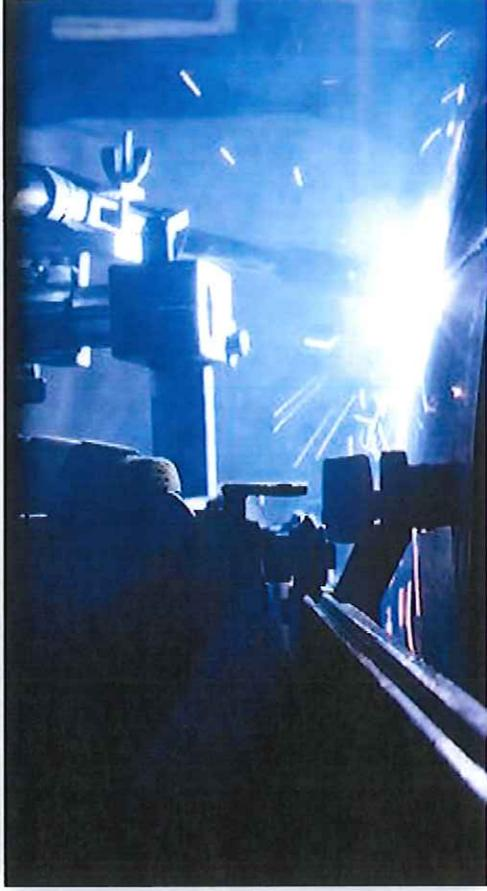

They say a house is only as good as it's foundation. If the foundation of a manufacturing company is it's factory, then we have a great base to build on. With over 350,000 square feet under roof, our plant provides us the opportunity to stabilize, modernize and improve the EZ-Pack Product line.

We are making investments in new technologies, new fixtures, and new methods of production to ensure that we stay competitive and deliver a high quality product that lives up to the EZ-Pack name.

We invite you to come see what we're about. Factory tours are always available, and we're excited to show our new home. Come meet the hard working men and women that actually build your next body. We'll even let you drive your completed unit off the line, just let us know and we'll be happy to arrange it.

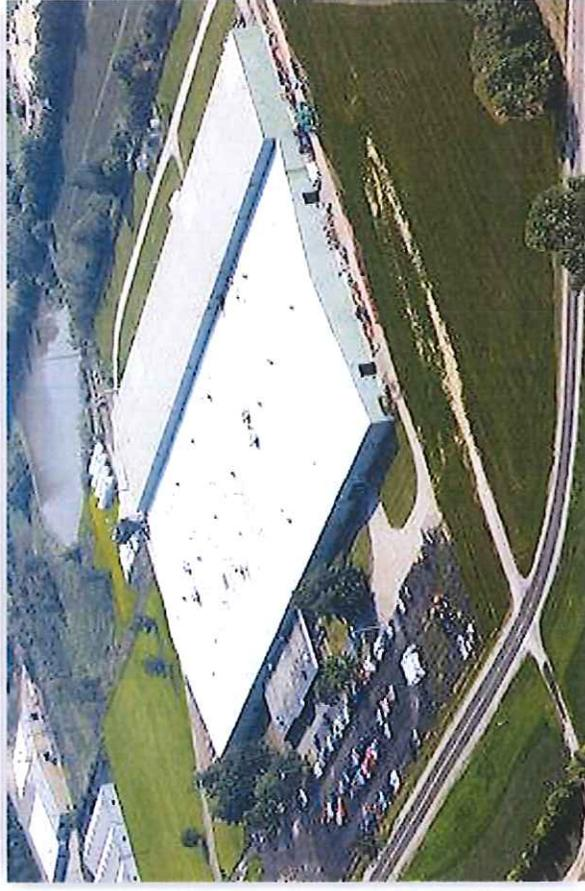

Warranty Description

Basic Vehicle Warranty (cab & chassis)	Length of Warranty Period (time, mileage, etc.)	Warranty Provided By:	Vendor agrees to warranty terms stated in paragraph 13.4?
		WE-Lep	<input checked="" type="radio"/> Yes / No
Basic Warranty (body)	Length of Warranty Period (time, mileage, etc.)	Warranty Provided By:	Vendor agrees to warranty terms stated in paragraph 13.4?
		WE-Lep	<input checked="" type="radio"/> Yes / No
Engine Warranty (paragraph 2.2)	Length of Warranty Period (time, mileage, etc.)	Warranty Provided By:	Vendor agrees to warranty terms stated in paragraph 13.4?
		WE-Lep	<input checked="" type="radio"/> Yes / No
Transmission Warranty (paragraph 2.11)	Length of Warranty Period (time, mileage, etc.)	Warranty Provided By:	Vendor agrees to warranty terms stated in paragraph 13.4?
		WE-Lep	<input checked="" type="radio"/> Yes / No
Exterior Finish Warranty (body)	Length of Warranty Period (time, mileage, etc.)	Warranty Provided By:	Vendor agrees to warranty terms stated in paragraph 13.4?
		SEE ATTACHED	Yes / No
Hydraulic Pump Warranty (paragraph 9.2)	Length of Warranty Period (time, mileage, etc.)	Warranty Provided By:	Vendor agrees to warranty terms stated in paragraph 13.4?
			Yes / No
Hydraulic Cylinder Warranty (body)	Length of Warranty Period (time, mileage, etc.)	Warranty Provided By:	Vendor agrees to warranty terms stated in paragraph 13.4?
			Yes / No
Back-Up Vision System Warranty (paragraph 10.8)	Length of Warranty Period (time, mileage, etc.)	Warranty Provided By:	Vendor agrees to warranty terms stated in paragraph 13.4?
			Yes / No

Other Information

Packer Performance	Clear Hopper Cycle Time (paragraph 7.3)	Load Sequence Cycle Time (paragraph 8.7)	Compaction (paragraph 7.4)

Exterior Finish (paragraph 10.6)	Describe painting or coating system for the exterior surfaces of the body.

Finished Overall Height (paragraph 10.9)	Measured height from the ground to the highest point of finished unit.	The LFUCG Division of Waste Management will have final approval of finished vehicle height. Stated heights in excess of thirteen feet (13') may be cause for rejection. Any unit whose measured height upon delivery exceeds that stated herein will not be accepted.

Warranty Description

Basic Vehicle Warranty (cab & chassis)	Length of Warranty Period (time, mileage, etc.)	Warranty Provided By:	Vendor agrees to warranty terms stated in paragraph 13.4?
			Yes / No

Basic Warranty (body)	Length of Warranty Period (time, mileage, etc.)	Warranty Provided By:	Vendor agrees to warranty terms stated in paragraph 13.4?
	1 Year	E-Z Pack	<input checked="" type="checkbox"/> Yes / No

Engine Warranty (paragraph 2.2)	Length of Warranty Period (time, mileage, etc.)	Warranty Provided By:	Vendor agrees to warranty terms stated in paragraph 13.4?
			Yes / No

Transmission Warranty (paragraph 2.11)	Length of Warranty Period (time, mileage, etc.)	Warranty Provided By:	Vendor agrees to warranty terms stated in paragraph 13.4?
			Yes / No

Exterior Finish Warranty (body)	Length of Warranty Period (time, mileage, etc.)	Warranty Provided By:	Vendor agrees to warranty terms stated in paragraph 13.4?
	1 Year	E-Z Pack	<input checked="" type="checkbox"/> Yes / No

Hydraulic Pump Warranty (paragraph 9.2)	Length of Warranty Period (time, mileage, etc.)	Warranty Provided By:	Vendor agrees to warranty terms stated in paragraph 13.4?
	1 Year	E-Z Pack	<input checked="" type="checkbox"/> Yes / No

Hydraulic Cylinder Warranty (body)	Length of Warranty Period (time, mileage, etc.)	Warranty Provided By:	Vendor agrees to warranty terms stated in paragraph 13.4?
	1 Year	E-Z Pack	<input checked="" type="checkbox"/> Yes / No

Back-Up Vision System Warranty (paragraph 10.8)	Length of Warranty Period (time, mileage, etc.)	Warranty Provided By:	Vendor agrees to warranty terms stated in paragraph 13.4?
	1 Year	E-Z Pack	<input checked="" type="checkbox"/> Yes / No

Other Information

Packer Performance	Clear Hopper Cycle Time (paragraph 7.3)	Load Sequence Cycle Time (paragraph 8.7)	Compaction (paragraph 7.4)
	25 sec	20 sec	950

Exterior Finish (paragraph 10.6)	Describe painting or coating system for the exterior surfaces of the body.
	Powder Coat

Finished Overall Height (paragraph 10.9)	Measured height from the ground to the highest point of finished unit.	The LFUCG Division of Waste Management will have final approval of finished vehicle height. Stated heights in excess of thirteen feet (13') may be cause for rejection. Any unit whose measured height upon delivery exceeds that stated herein will not be accepted.
	With arms down 12'9"	