



Response to: **Bid Number: 189-2015**

AudioVisual Systems for PSOC

Prepared by:

Collin McGinley, Account Executive
Rebecca Betts, Director of Business Development
M3 Technology Group, Inc.

Date:

December 30, 2015

Submitted to:

LFUCG
Director, Division of Central Purchasing
Third Floor, 200 East Main Street
Lexington, KY 40507



Nashville | Knoxville | Memphis | Huntsville

877-227-0171 | M3TechGroup.com

Nashville

925 Airpark Center Drive
Nashville, TN 37217
615-227-0717

Knoxville

8705 Unicorn Drive, #114
Knoxville, TN 37923
865-691-1124



Table of Contents

- General Information 4**
 - M3 Contacts 4
 - M3 Corporate Contact Info: 4
- Forward 5**
- Statement of Understanding 5**
- Scope of Work 6**
 - Required Services 6
 - Project Resources 6
 - Technicians 6
 - Project Managers 6
 - Service Resources 6
 - Schedule of Implementation 6
 - Status Reports 6
 - Project Team Personnel 6
- 1. Form of Proposal 7**
- 2. Legal Status of Bidder 9**
- 3. Bidders Affidavit 10**
- 4. Bid Schedule – Schedule of Values 11**
- 5. Statement of Bidder’s Qualifications 14**
- 6. List of Proposed Subcontractors 16**
- 7. LFUCG MWDBE Participation Goals, Forms and Good Faith Efforts 17**
 - LFUCG MWDBE Participation Form 17
 - LFUCG MWDBE Substitution Form 18
 - LFUCG MWDBE Quote Summary Form 19
 - LFUCG Statement of Good Faith Efforts 20
- 8. Authentication of Bid and Statement of Non-Collusion, Non-Conflict of Interest 22**
- 9. Statement of Experience 23**
- 10. Equal Opportunity Agreement 25**
- 11. Equal Employment Opportunity Affirmative Action Policy 27**
- 12. Workforce Analysis Form 28**
- 13. Evidence of Insurability 29**
- 14. Debarred Firms 30**
- 15. Debarment Certification 31**
- Line Item Pricing 32**
- Pricing Optional Years 2 through 5 Maintenance Agreement 43**
- Bid Bond 44**
- Line Drawings 46**
 - A101 46
 - AV-101 47
 - AV-102 48
 - AV-103 49
 - AV-104 50

MC-101	51
RK-101	52
DM Switcher Configuration	53
High Level Project Plan	57
Gantt Chart.....	58
Preventative Maintenance Plan Coverage and Description.....	59
About M3 Technology Group	60
Company Overview	60
Ownership	60
Staff and Office Locations	61
Summary of Capabilities.....	61
Mission Statement	61
Drug Free Workplace	62
Employee Competence	62
Employee Certifications	62
AV/IT Technology Reseller Status.....	62
Authorized Service Center.....	62
Office Locations.....	63
M3 Applicable State Licensing	64
M3 Number/Type of Employees.....	64
M3 Industry Certifications & Associations.....	65
Project Experience	65
Industry Associations	65
Certification Summary	65
M3 Service & Support Capabilities.....	66
A note about documentation.....	66
M3 Workmanship	67
Service Delivery	68
M3 Technical Service & Support Services	68
AV System Integration Process Overview	72
Planning/Programming/Design Phase	72
Construction Phase	72
Installation Phase	72
Handover/Training/Warranty	73
Warranty	73
Warranty Statement	73
Standard Workmanship Warranty	73
Manufacturer Warranties	73
Preventive Maintenance & Service Contract	74
One year (PMP) Preventative Maintenance Plan Overview	74
Partial Client List.....	75
Government/Municipalities	75
Related AV Project Reference, Video Walls.....	77
Government: Nashville Electric Service – Security NOC	77

Higher Education: Vanderbilt University Network Operations Center	77
Government: Tennessee Army National JEOC (Joint Emergency Operations Center)	77
Government: US Army Space/Missile Defense, Secure VTC Command Center	77
Tennessee Army National Guard Command Conference Room.....	77
AV Equipment Directory.....	78
Manufacturer Certifications List	82
AMX by Harman	82
BiAmp	82
BICSI.....	82
Cambridge Sound Management	82
Cisco	82
ClearOne.....	82
Commscope.....	83
Crestron.....	83
Extron	84
InfoComm.....	84
Hubbell	84
KBZ Communications/Cisco Training	85
Optical Cable Corp.....	85
PolyCom	85
BICSI.....	85
RevoLabs	85
Volante /SVSi.....	85
Yamaha.....	86
Authorized Service Center.....	86
Computer Software Systems.....	86
System Test Equipment.....	86

General Information

M3 Contacts

The following M3 representatives are primary contact personnel relating to this project:

Primary Contact during RFP Process:

Sales Representative:

David West, Branch Manager

Tel: 877-227-0717 | email davidwest@m3techgroup.com

Collin McGinley, Account Manager

Tel: 877-227-0717 | email: collinmcginley@m3techgroup.com

Rebecca Betts, Director of Business Development

Tel: 615-227-0717 | rebeccabetts@m3techgroup.com

Service Representative:

Phillip Cordell, Director of Engineering

Tel: 615-227-0717 | email: phillipcordell@m3techgroup.com

M3 Corporate Contact Info:

Mailing Address:

Headquarters:

M3 Technology Group, Inc.
925 Airpark Center Drive
Nashville, TN 37217

Branch:

8705 Unicorn Drive, A114
Knoxville, TN 37923

Tel: 615-227-0717 / 877-227-0717

Fax: 615-227-2788

Forward

M3 Technology Group Inc. offers the enclosed response to Request for Bid for AudioVisual Systems for PSOC in accordance with the project specifications issued by Lexington Fayette Urban County Government

Supplemental information may be appended to this proposal in accordance with the specifications as follows:

- Contractor Qualification Requirements Form
- M3 company overview, project references, client testimonials and additional supporting materials for demonstrating M3's exceptional reputation and experience delivering projects of this nature. A listing of these items is provided in the Table of Contents.

Statement of Understanding

M3 understands that the objective of this RFB is to furnish all labor, equipment and materials as listed in the Bid Schedule for the Audiovisual Systems for PSOC, Lexington-Fayette County, Kentucky.

Scope of Work

Required Services

M3 Technology Group has included in this proposal response the design/engineering of the system including the control programming, dedicated project management, mock-up, installation, testing, commissioning and training. Included also are miscellaneous items such as cable, connectors, equipment rack hardware, travel, freight, documentation as well as required pricing for optional service plans.

Project Resources

Technicians

M3 has 14 full-time Installation technicians between the Nashville and Knoxville branches, all of whom can be called upon as needed to pull cable and deploy technology throughout the course of the project. In addition, M3 has an additional sub-contractor pool of approximately 25 technicians who can aid in the installation process.

Project Managers

M3 has six full-time industry accredited, seasoned Project Managers. Should additional support be required outside of normal business hours M3 will assign a parallel Project Manager to assist as needed to ensure uninterrupted workflow.

Service Resources

877-227-0717 | Service@M3TechGroup.com Help Desk: 8am - 5pm (CST) Monday – Friday access.

M3 provides customers with on-call technical support during normal business hours. M3 additionally employs an emergency escalation process and resource team for critical service needs outside of the regular business hours in accordance with optional Service Plan provisions, provided separately.

Schedule of Implementation

A proposed Schedule of Implementation is provided separately.

Status Reports

M3 provides weekly progress reports outlining the work accomplished for the current week, planned for the following week, and also reporting on any issues encountered and whether they will or will not have an impact on the overall timeline. This information shall be maintained within the Schedule of Implementation.

Project Team Personnel

M3 Technology Group assembles project teams and allocates labor resources according to workload schedules with assurance of proper staffing to perform all functions associated with each project as defined per the agreed-to timeline established for that project.

All team members have full access to related project documentation and equipment.

PART III

Invitation to Bid No. 189-2015

Audiovisual Systems for PSOC

1. FORM OF PROPOSAL

Place: Lexington, Kentucky

Date: December 29, 2015

The following Form of Proposal shall be followed exactly in submitting a proposal for this Work.

This Proposal Submitted by M3 Technology Group, Inc.

925 Airpark Center Drive Nashville, TN 37217

(Name and Address of Bidding Contractor)

(Hereinafter called "Bidder"), organized and existing under the laws of the State of Tennessee, doing business as M3 Technology Group, Inc. dba Multi-Media Masters, Inc. "a corporation" "a corporation," "a partnership", or an "individual" as applicable.

To: Lexington-Fayette Urban County Government
(Hereinafter called "OWNER")
Office of the Director of Purchasing
200 East Main Street, 3rd Floor
Lexington, KY 40507

Gentlemen:

The Bidder, in compliance with your Invitation for Bids for **Audiovisual Systems for PSOC** having examined the Plans and Specifications with related documents, having examined the site for proposed Work, and being familiar with all of the conditions surrounding the construction of the proposed Project, including the availability of materials and labor, hereby proposes to furnish all labor, materials, and supplies, and to construct the Project in accordance with the Contract Documents, within the time set forth therein, and at the lump sum and/or unit prices stated hereinafter. These prices are to cover all expenses incurred in performing the Work required under the Contract Documents, of which this proposal is a part. The OWNER will issue work orders for work to be performed under this Contract.

BIDDER hereby agrees to commence work under this contract on or before a date to be specified in the Notice to Proceed and to fully complete the project within the time provided in the Purchase Order or Work Orders issued by the OWNER. BIDDER further agrees to pay liquidated damages, the sum of NA for each consecutive calendar day thereafter.

The Bidder hereby acknowledges receipt of the following addenda:

Addendum No. 1 Date 12/17/2015

Addendum No. Date

Addendum No. Date

Addendum No. Date

Addendum No. Date

Addendum No. Date

Addendum No. Date

Addendum No. Date

Insert above the number and the date of any Addendum issued and received. If none has been issued and received, the word "NONE" should be inserted.

2. **LEGAL STATUS OF BIDDER**

Bidder M3 Technology Group, Inc. dba Multi-Media Masters, Inc.

Date December 29, 2015

* 1. A corporation duly organized and doing business under the laws of the State of Tennessee, for whom Jason Taylor, bearing the official title of Chief Executive Officer, whose signature is affixed to this Bid/Proposal, is duly authorized to execute contracts.

* 2. ~~A Partnership, all of the members of which, with addresses are. (Designate general partners as such)~~

* 3. ~~An individual whose signature is affixed to this Bid/Proposal (please print name)~~

*(The Bidder shall fill out the appropriate form and strike out the other two.)

3. **BIDDERS AFFIDAVIT**

Comes the Affiant, Jason Taylor, and after being first duly sworn, states under penalty of perjury as follows:

1. His/her name is Jason Taylor and he/she is the individual submitting the bid or is the authorized representative of M3 Technology Group, Inc. dba Multi-Media Masters, Inc., the entity submitting the bid (hereinafter referred to as "Bidder").
 2. Bidder will pay all taxes and fees, which are owed to the Lexington-Fayette Urban County Government at the time the bid is submitted, prior to award of the contract and will maintain a "current" status in regard to those taxes and fees during the life of the contract.
 3. Bidder will obtain a Lexington-Fayette Urban County Government business license, if applicable, prior to award of the contract.
 4. Bidder has authorized the Division of Central Purchasing to verify the above-mentioned information with the Division of Revenue and to disclose to the Urban County Council that taxes and/or fees are delinquent or that a business license has not been obtained.
 5. Bidder has not knowingly violated any provision of the campaign finance laws of the Commonwealth of Kentucky within the past five (5) years and the award of a contract to the Bidder will not violate any provision of the campaign finance laws of the Commonwealth.
 6. Bidder has not knowingly violated any provision of Chapter 25 of the Lexington-Fayette Urban County Government Code of Ordinances, known as the "Ethics Act."
 7. Bidder acknowledges that "knowingly" for purposes of this Affidavit means, with respect to conduct or to circumstances described by a statute or ordinance defining an offense, that a person is aware or should have been aware that his conduct is of that nature or that the circumstance exists.
- Further, Affiant sayeth naught.

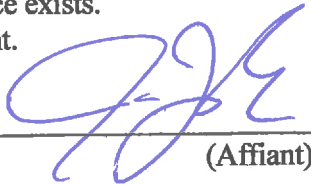

(Affiant)

STATE OF Tennessee
COUNTY OF Sumner

The foregoing instrument was subscribed, sworn to and acknowledged before me by Jason Taylor on this the 28th day of December, 2015.

My Commission expires: 5-22-18



NOTARY PUBLIC, STATE AT LARGE

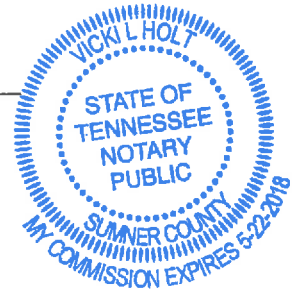

4. BID SCHEDULE – SCHEDULE OF VALUES

The Bidder agrees to perform all the Work described in the Specifications and shown on the Plans for the following proposed lump sum and/or unit prices, if applicable, which shall include the furnishing of all labor, materials, supplies, equipment and/or vehicle usage, services, all items of cost, overhead, taxes (federal, state, local), and profit for the Contractor and any Subcontractor involved, within the time set forth herein. If unit prices are applicable, Bidder must make the extensions and additions showing the total amount of bid.

Form of proposal must include unit bid prices written in words, unit price written in numbers and total amount bid (unit price x quantity) per line item OR bid may be considered non-responsive. In case of price discrepancy, unit bid price written in words will prevail followed by unit price written in numbers then total amount bid per line item.

If a discrepancy between the unit price and the item total exists, the unit price prevails except:

If the unit price is illegible, omitted, or the same as the item total, item total prevails and the unit price is the quotient of the item total and the quantity.

If the unit price and the item total are illegible or are omitted, the bid may be determined nonresponsive. If a lump sum total price is illegible or is omitted, the bid may be determined nonresponsive.

For a lump sum based bid, the item total is the bid amount the Division uses for bid comparison.

For a unit price based bid, the sum of the item totals is the bid amount the Division uses for bid comparison.

The LFUCG’s decision on the bid amount is final.

Item No.	Description w/Unit Bid Price Written in Words	Unit	Total Bid Amount
1a.	LexCall 311 (Room 112) Equipment/Materials for Seven Thousand Seventy Seven _____ Dollars Seventy Seven _____ Cents	LS	\$ <u>7077.77</u>
1b.	LexCall 311 (Room 112) Labor for Two Thousand One Hundred Ninety One _____ Dollars Eighty three _____ Cents	LS	\$ <u>2191.83</u>
2a.	LexCall 311 Conference Room (Room 115) Equipment/ Materials for Seven Thousand Four Hundred Fifty One _____ Dollars Seventy Seven _____ Cents	LS	\$ <u>7451.77</u>
2b.	LexCall 311 Conference Room (Room 115) Labor for Eight Hundred Ninety Three _____ Dollars One _____ Cents	LS	\$ <u>893.01</u>
3a.	EOC (Room 129) Equipment/Material for Eighty Thousand Eight Hundred Four _____ Dollars Seventy Seven _____ Cents	LS	\$ <u>80,804.77</u>
3b.	EOC (Room 129) Labor for Thirteen Thousand Eight Hundred Seventy Seven _____ Dollars Seventy Two _____ Cents	LS	\$ <u>13,877.72</u>

Item No.	Description w/Unit Bid Price Written in Words	Unit	Total Bid Amount
4a.	Policy (Room 127) Equipment/Material for Twenty One Thousand Six hundred Forty----- Dollars Seventy Seven----- Cents	LS	\$ 21,640.77
4b.	Policy (Room 127) Labor for Four Thousand Five Hundred Eleven----- Dollars Twenty Four----- Cents	LS	\$ 4,511.24
5a.	Breakout Rooms (Room 125, 126, 130 and 131) Equipment/Material for Sixty Eight Thousand Two Hundred Ninety Six-----Dollars Fifty Four----- Cents	LS	\$ 68,296.54
5b.	Breakout Rooms (Room 125, 126, 130 and 131) Labor for Eight Thousand Eight Hundred Twenty Three----- Dollars Fifty Three-----Cents	LS	\$ 8,823.53
6a.	Press (Room 122) Equipment/Material for Forty Nine Thousand Eight Hundred Sixty Four-----Dollars Seventy Seven-----Cents	LS	\$ 49,864.77
6b.	Press (Room 122) Labor for Eleven Thousnd Two Hundred Sixty One----- Dollars Ninety Two----- Cents	LS	\$ 11,261.92
7a.	Joint Information Center (Room 123) Equipment/Material for Fifteen Thousnd Three Hundred Ninety Six-----Dollars Seventy Seven-----Cents	LS	\$ 15,396.77
7b.	Joint Information Center (Room 123) Labor for Three Thousand Eight Hundred Forty Nine----- Dollars Sixteen----- Cents	LS	\$ 3,849.16
8a.	ESF2 (Room 124) Equipment/Material for Two Thousand Four Hundred Forty Six----- Dollars Seventy Seven----- Cents	LS	\$ 2,446.77
8b.	ESF2 (Room 124) Labor for Eight Hundred Sixty Seven Dollars----- Dollars Sixty Six-----Cents	LS	\$ 867.66
9a.	911 Training (Room 144) Equipment/Material for Seventeen Thousand Eight Hundred Sixteen-----Dollars Seventy Seven----- Cents	LS	\$ 17,816.77
9b.	911 Training (Room 144) Labor for One Thousand Eight Hundred Sixty----- Dollars Fifty Six-----Cents	LS	\$ 1,860.56
10a.	Individual Offices/Rooms Equipment/Material for Ten Thousand Three Hundred Eighty Three-----Dollars Eight-----Cents	EA	\$ 10,383.08
10b.	Individual Offices/Rooms Labor for Three Thiousand One Hundred Thirty Seven-----Dollars Thirty Six----- Cents	EA	\$ 3,137.36
11a.	Matrix Switching System Equipment/Material for Fifty Six Thousand Five Hundred Twenty Two----- Dollars Thirty One----- Cents	LS	\$ 56,522.31

Item No.	Description w/Unit Bid Price Written in Words	Unit	Total Bid Amount
11b.	Matrix Switching System Labor for Fourteen Thousand Nine Hundred Ninety Five----- Dollars Seventy Two----- Cents	LS	\$ 14,995.72

TOTAL OF ALL BID PRICES FOR Audiovisual System for PSOC Project (Items 1 through 11) in words and figures. In case of discrepancy, the amount shown in words will govern.

Four Hundred Three Thousand Nine Hundred Seventy One Dollars and 80 cents

(\$ 403,971.80).

Submitted by:

M3 Technology Group, Inc. dba Multi-Media Masters, Inc.

Firm

925 Airpark Center Drive

Address

Nashville, TN 37217

City, State & Zip

**Bid must be signed:
(original signature)**



Signature of Authorized Company Representative – Title

Jason Taylor, CEO

Representative/s Name (Typed or Printed)

615-227-0717

Area Code – Phone – Extension

615-227-2788

Fax #

jasontaylor@m3techgroup.com

E-Mail Address

OFFICIAL ADDRESS:

925 Airpark Center Drive

Nashville, TN 37217

(Seal if Bid is by Corporation)

By signing this form you agree to ALL terms, conditions, and associated forms in this bid package

5. **STATEMENT OF BIDDER'S QUALIFICATIONS**

The following statement of the Bidder's qualifications is required to be filled in, executed, and submitted with the Proposal:

1. Name of Bidder: M3 Technology Group, Inc. dba Multi-Media Masters, Inc.

2. Permanent Place of Business: 925 Airpark Center Drive Nashville, TN 37217

3. When Organized: 1/2/2002

4. Where Incorporated: State of Tennessee

5. Construction Plant and Equipment Available for this Project:

Various small tools used for installation; AutoCad 2013; Adobe CS5 Suite; Microsoft Office;

Extron VTG 400DVI; Test-UM LanRover PRP TP600 Network Tool/Tester;

Fluke DTX 1800 with single and multi-mode fiber modules; Leade LD941D Signal level meter

Sound Devuce USB pre-amp Audix TM271 calibrated mic and SmartLive Calibration software

for room tuning

(Attach Separate Sheet If Necessary)

6. Financial Condition:

If specifically requested by the OWNER, the apparent low Bidder is required to submit its latest three (3) years audited financial statements to the OWNER'S Division of Central Purchasing within seven (7) calendar days following the bid opening.

7. In the event the Contract is awarded to the undersigned, surety bonds will be furnished by:

Amco Insurance Company (Surety)

Signed:  (Representative of Surety)

8. The following is a list of similar projects performed by the Bidder: (Attach separate sheet if necessary).

<u>NAME</u>	<u>LOCATION</u>	<u>CONTRACT SUM</u>
Clark County EOC	Winchester, KY	\$99407.23
Rockcastle County EOC	Mt. Vernon, KY	\$63387.34
Vanderbilt EOC - Power Plant	Nashville, TN	\$92243.03
TN Army National Guard JEOC	Nashville, TN	\$125,000.00
Nashville Electric - Security NOC	Nashville, TN	\$138,225.00

9. The Bidder has now under contract and bonded the following projects:

<u>NAME</u>	<u>LOCATION</u>	<u>CONTRACT SUM</u>
Knoxville Utilities - HOC	Knoxville, TN	\$211,152.98
University of Louisville - Nursing Bldg.	Louisville, KY	\$128,735.38

10. List Key Bidder Personnel who will work on this Project.

<u>NAME</u>	<u>POSITION DESCRIPTION</u>	<u>NO. OF YEARS WITH BIDDER</u>
David West	Branch Manager - Knoxville	7 years
Kyle Jackman	Project Manager	5 years
Jonathan Starnes	Installer	3 years

11. DBE Participation on current bonded projects under contract: NONE

<u>SUBCONTRACTORS</u> <u>(LIST)</u>	<u>PROJECT</u> <u>(SPECIFIC TYPE)</u>	<u>DBE</u>	<u>% of WORK</u>
_____	_____	_____	_____
_____	_____	_____	_____
_____	_____	_____	_____
_____	_____	_____	_____
_____	_____	_____	_____
_____	_____	_____	_____
_____	_____	_____	_____

(USE ADDITIONAL SHEETS IF NECESSARY)

12. We acknowledge that, if we are the apparent low Bidder, we may be required to submit to the OWNER within 7 calendar days following the Bid Opening, a sworn statement regarding all current work on hand and under contract, and a statement on the OWNER'S form of the experience of our officers, office management and field management personnel. Additionally, if requested by the OWNER, we will within 7 days following the request submit audited financial statements and loss history for insurance claims for the 3 most recent years (or a lesser period stipulated by the OWNER).

6. LIST OF PROPOSED SUBCONTRACTORS

The following list of proposed subcontractors is required by the OWNER to be executed, completed and submitted with the BIDDER'S FORM OF PROPOSAL. All subcontractors are subject to approval of the Lexington-Fayette Urban County Government. Failure to submit this list completely filled out may be cause for rejection of bid.

<u>BRANCH OF WORK - LIST EACH MAJOR ITEM</u> Such as: Grading, bituminous paving, concrete, seeding and protection, construction staking, etc.	<u>SUBCONTRACTOR</u>	<u>DBE</u> <u>Yes/No</u>	<u>% of Work</u>
1. <u>NONE</u>	Name: <u>NONE</u>	_____	_____
	Address: _____		
2. _____	Name: _____	_____	_____
	Address: _____		
3. _____	Name: _____	_____	_____
	Address: _____		
4. _____	Name: _____	_____	_____
	Address: _____		
5. _____	Name: _____	_____	_____
	Address: _____		
6. _____	Name: _____	_____	_____
	Address: _____		
7. _____	Name: _____	_____	_____
	Address: _____		

(Attach additional sheet(s) if necessary.)



LFUCG MWDBE PARTICIPATION FORM

Bid/RFP/Quote Reference # **Bid No.** 189-2015

The MWDBE subcontractors listed have agreed to participate on this Bid/RFP/Quote. If any substitution is made or the total value of the work is changed prior to or after the job is in progress, it is understood that those substitutions must be submitted to Central Purchasing for approval immediately.

MWDBE Company, Name, Address, Phone, Email	Work to be Performed	Total Dollar Value of the Work	% Value of Total Contract
1. NONE			
2.			
3.			
4.			

The undersigned company representative submits the above list of MWDBE firms to be used in accomplishing the work contained in this Bid/RFP/Quote. Any misrepresentation may result in the termination of the contract and/or be subject to applicable Federal and State laws concerning false statements and false claims.

M3 Technology Group, Inc. dba Multi-Media Masters, Inc.
Company 
Company Representative

December 29, 2015
Date CEO
Title



LFUCG MWDBE SUBSTITUTION FORM

Bid/RFP/Quote Reference # Bid No. 189-2015

The substituted MWDBE subcontractors listed below have agreed to participate on this Bid/RFP/Quote. These substitutions were made prior to or after the job was in progress. These substitutions were made for reasons stated below and are now being submitted to Central Purchasing for approval. By the authorized signature of a representative of our company, we understand that this information will be entered into our file for this project.

SUBSTITUTED MWDBE Company Name, Address, Phone, Email	MWDBE Formally Contracted/ Name, Address, Phone, Email	Work to Be Performed	Reason for the Substitution	Total Dollar Value of the Work	% Value of Total Contract
1. NONE					
2.					
3.					
4.					

The undersigned acknowledges that any misrepresentation may result in termination of the contract and/or be subject to applicable Federal and State laws concerning false statements and false claims.

M3 Technology Group, Inc. dba Multi-Media Masters, Inc. 
 Company Company Representative
 December 29, 2015 CEO
 Date Title



MWDBE QUOTE SUMMARY FORM

Bid/RFP/Quote Reference # Bid No. 189-2015

The undersigned acknowledges that the minority subcontractors listed on this form did submit a quote to participate on this project.

Company Name M3 Technology Group, Inc. dba Multi-Media Masters, Inc.	Contact Person Rebecca Betts
Address/Phone/Email 925 Airpark Center Drive Nashville, TN 37217	Bid Package / Bid Date Bid No. 189-2015

MWDBE Company Address	Contact Person	Contact Information (work phone, Email, cell)	Date Contacted	Services to be performed	Method of Communication (email, phone meeting, ad, event etc)	Total dollars \$\$ Do Not Leave Blank (Attach Documentation)	MBE * AA HA AS NA Female
NONE							

(MBE designation / AA=African American / HA= Hispanic American/AS = Asian American/Pacific Islander/ NA= Native American)

The undersigned acknowledges that all information is accurate. Any misrepresentation may result in termination of the contract and/or be subject to applicable Federal and State laws concerning false statements and claims.

M3 Technology Group, Inc. dba Multi-Media Masters, Inc.
Company

Company Representative

December 29, 2015

CEO

Date

Title

LFUCG STATEMENT OF GOOD FAITH EFFORTS

Bid/RFP/Quote # Bid No. 189-2015

NONE; Due to the complexity and training requirements, M3 does

does not subcontract any scope of the project

By the signature below of an authorized company representative, we certify that we have utilized the following Good Faith Efforts to obtain the maximum participation by MWDBE business enterprises on the project and can supply the appropriate documentation.

N/A Advertised opportunities to participate in the contract in at least two (2) publications of general circulation media; trade and professional association publications; small and minority business or trade publications; and publications or trades targeting minority, women and disadvantaged businesses not less than fifteen (15) days prior to the deadline for submission of bids to allow MWDBE firms to participate.

N/A Included documentation of advertising in the above publications with the bidders good faith efforts package

N/A Attended LFUCG Central Purchasing Economic Inclusion Outreach event

N/A Attended pre-bid meetings that were scheduled by LFUCG to inform MWDBEs of subcontracting opportunities

N/A Sponsored Economic Inclusion event to provide networking opportunities for prime contractors and MWDBE firms

N/A Requested a list of MWDBE subcontractors or suppliers from LFUCG Economic Engine and showed evidence of contacting the companies on the list(s).

N/A Contacted organizations that work with MWDBE companies for assistance in finding certified MWDBE firms to work on this project. Those contacted and their responses should be a part of the bidder's good faith efforts documentation.

N/A Sent written notices, by certified mail, email or facsimile, to qualified, certified MWDBEs soliciting their participation in the contract not less than seven (7) days prior to the deadline for submission of bids to allow them to participate effectively.

N/A Followed up initial solicitations by contacting MWDBEs to determine their level of interest.

N/A Provided the interested MWDBE firm with adequate and timely information about the plans, specifications, and requirements of the contract.

N/A Selected portions of the work to be performed by MWDBE firms in order to increase the likelihood of meeting the contract goals. This includes, where appropriate, breaking out contract work items into economically feasible units to facilitate MWDBE participation, even when the prime contractor may otherwise perform these work items with its own workforce

- N/A Negotiated in good faith with interested MWDBE firms not rejecting them as unqualified without sound reasons based on a thorough investigation of their capabilities. Any rejection should be so noted in writing with a description as to why an agreement could not be reached.
- N/A Included documentation of quotations received from interested MWDBE firms which were not used due to uncompetitive pricing or were rejected as unacceptable and/or copies of responses from firms indicating that they would not be submitting a bid.
- N/A Bidder has to submit sound reasons why the quotations were considered unacceptable. The fact that the bidder has the ability and/or desire to perform the contract work with its own forces will not be considered a sound reason for rejecting a MWDBE quote. Nothing in this provision shall be construed to require the bidder to accept unreasonable quotes in order to satisfy MWDBE goals.
- N/A Made an effort to offer assistance to or refer interested MWDBE firms to obtain the necessary equipment, supplies, materials, insurance and/or bonding to satisfy the work requirements of the bid proposal
- N/A Made efforts to expand the search for MWDBE firms beyond the usual geographic boundaries.
- N/A Other - any other evidence that the bidder submits which may show that the bidder has made reasonable good faith efforts to include MWDBE participation.

Failure to submit any of the documentation requested in this section may be cause for rejection of bid. Bidders may include any other documentation deemed relevant to this requirement. Documentation of Good Faith Efforts are to be submitted with the Bid, if the participation Goal is not met.

The undersigned acknowledges that all information is accurate. Any misrepresentations may result in termination of the contract and/or be subject to applicable Federal and State laws concerning false statements and claims.

M3 Technology Group, Inc. dba Multi-Media Masters, Inc.

 Company

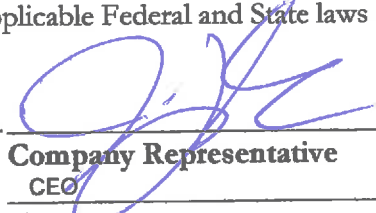

 Company Representative
 CEO

 Title

 Date

8. AUTHENTICATION OF BID AND STATEMENT OF NON-COLLUSION, NON-CONFLICT OF INTEREST

I hereby swear (or affirm) under the penalty for false swearing:

1. That I am the Bidder (if the Bidder is an individual), a partner of the Bidder (if the Bidder is a partnership), or an officer or employee of the bidding corporation having authority to sign on its behalf (if the Bidder is a corporation);
2. That the attached bid has been arrived at by the Bidder independently, and has been submitted without collusion with, and without any agreement, understanding or planned common course of action, with any other contractor, vendor of materials, supplies, equipment or services described in the Invitation to Bid, designed to limit independent bidding or competition;
3. That the contents of the bid or bids have not been communicated by the Bidder or its employees or agents to any person not an employee or agent of the Bidder or its surety on any bond furnished, with the bid or bids, and will not be communicated to any such person, prior to the official opening of the bid or bids;
4. That the Bidder is legally entitled to enter into the contracts with the Lexington-Fayette Urban County Government, and is not in violation of any prohibited conflict of interest;
5. (Applicable to corporation only) That as a foreign corporation, we are registered with the Secretary of State, Commonwealth of Kentucky, and authorized to do business in the State _____ or, that as a domestic corporation, we are in good standing with the Secretary of State, Commonwealth of Kentucky X . Check the statement applicable.
6. This offer is for 60 calendar days from the date this bid is opened. In submitting the above, it is expressly agreed that, upon proper acceptance by the Lexington-Fayette Urban County Government of any or all items bid above, a contract shall thereby be created with respect to the items accepted.
7. That I have fully informed myself regarding the accuracy of the statements made in this statement.
8. That I certify that Subcontractors have not and will not be awarded to any firm(s) that have been debarred from noncompliance with the Federal Labor Standards, Title VI of the Civil Rights Act of 1964 As Amended, Executive Order 11246 As Amended or any other Federal Law.

9. STATEMENT OF EXPERIENCE

NAME OF INDIVIDUAL: David West

POSITION/TITLE: Branch Manager

STATEMENT OF EXPERIENCE: 32+ years in low voltage industry (operations, field, project management)

Certifications: Low Voltage License, OCC MDIS. Oversees all of M3 Technology Group's audio-video systems integration department as well as low voltage structured cabling.

Project Experience: Rockcastle Co. EOC, Clark Co. EOC, Verizon Wireless, Bush Bros, Scripps Network., etc.

NAME OF INDIVIDUAL: Kyle Jackman

POSITION/TITLE: Project Manager / Systems Programmer

STATEMENT OF EXPERIENCE: 10+ years in the AV and IT industry. Certifications: InfoComm CTS,

Crestron DMC-T; Crestron Ess. of Programming, Crestro Intro to Programming, Crestron CTI-P201, DMC-4-4K, DMC-E-4k,

Clearone Univ Cert Audio Conf. Specialist, Biamp Tesira, AMX NAM Programming,

Project Experience: Rockcastle Co EOC, Clark Co EOC, Lincoln Mem Univ, Roane State CC, Bush Bros., Team Health, etc.

NAME OF INDIVIDUAL: Jonathan Stames

POSITION/TITLE: Lead Technician

STATEMENT OF EXPERIENCE: 8+ years experience in both Low Voltage and AV Industry. Degree SAE Institute

Certifications: Crestron DM, Panduit cable termination, Chief, OCC copper/fiber, TE

Projects: Walters State Univ, Chattanooga State Univ, Valley Grove Baptist Church, Radio Systems, Chambliss Law,

Team Health, etc.

NAME OF INDIVIDUAL: Jason Taylor

POSITION/TITLE: CEO

STATEMENT OF EXPERIENCE: 21 years in the AV/telecommunications industry

Certifications: CTS-D, CTS-I, Crestron DMC-T, Crestron programming, essentials/intermediate, AMX Programmer,

Extron SAVTSD, BiAmp Audia, Cambridge Sound Management CME

NAME OF INDIVIDUAL: Phillip Cordell

POSITION/TITLE: Director of Engineering

STATEMENT OF EXPERIENCE: 15+ years in the Audio Visual Industry. Certifications:

CTS, CTS-D, InfoCom,m Installation, Crestron DMC-T, Programmer Configuration, Essentials, Intermediate

BiAmp AVB, Extron SDAVT, Crestron Programmer, Polycom Infrastructure Training/Solution Technical Training,

Cisco EVS Account Manager

NAME OF INDIVIDUAL: Chris Montini

POSITION/TITLE: Chief Technology Officer; Safety Director

STATEMENT OF EXPERIENCE: 15+ years in the Audio Visual Industry. Certifications:

AMX Designer - Installer - Programmer, ACE-Designer Certified Expert, BiAmp Audia Training, Crestron DMC-T

Extron AV Technical System Designer - Configurable Control Systems, CTS, Cisco EVS Engineer Certification

Cisco Select Partner Technical Training, Polycom Installed Voice Pre-Sales Technical Training -

Polycom Installed Boice Solutions Sales - Video Solutions Pre-Sale Technical - Video Solution Sales

Revolabs Installed Wireless Systems

* Include all officers, office management's, Affirmative Action officials, and field management personnel. (Attach separate sheets if necessary.)

NAME OF INDIVIDUAL: Rusty Howell

POSITION/TITLE: V.P., Secretary

STATEMENT OF EXPERIENCE: 18+ years in the Audio Visual Industry

NAME OF INDIVIDUAL: Bruce Cordell

POSITION/TITLE: Chairman

STATEMENT OF EXPERIENCE: 18+ years in the Audio Visual Industry

NAME OF INDIVIDUAL: Kelly Burns

POSITION/TITLE: COO

STATEMENT OF EXPERIENCE: 14+ years in the AV Industry

* Include all officers, office management's, Affirmative Action officials, and field management personnel. (Attach separate sheets if necessary.)

10. EQUAL OPPORTUNITY AGREEMENT

The Law

- * Title VII of the Civil Rights Act of 1964 (amended 1972) states that it is unlawful for an employer to discriminate in employment because of race, color, religion, sex, age (40-70 years) or national origin.
- * Executive Order No. 11246 on Nondiscrimination under Federal contract prohibits employment discrimination by contractor and subcontractor doing business with the Federal Government or recipients of Federal funds. This order was later amended by Executive Order No. 11375 to prohibit discrimination on the basis of sex.
- * Section 503 of the Rehabilitation Act of 1973 States:

The Contractor will not discriminate against any employee or applicant for employment because of physical or mental handicap.

- * Section 2012 of the Vietnam Era Veterans Readjustment Act of 1973 requires Affirmative Action on behalf of disabled veterans and veterans of the Vietnam Era by contractors having Federal Contracts.
- * Section 206 (A) of Executive Order 12086, Consolidation of Contract Compliance Functions for Equal Employment Opportunity, states:

The Secretary of Labor may investigate the employment practices of any Government contractor or sub-contractor to determine whether or not the contractual provisions specified in Section 202 of this order have been violated.

The Lexington-Fayette Urban County Government practices Equal Opportunity in recruiting, hiring and promoting. It is the Government's intent to affirmatively provide employment opportunities for those individuals who have previously not been allowed to enter into the mainstream of society. Because of its importance to the local Government, this policy carries the full endorsement of the Mayor, Commissioners, Directors, and all supervisory personnel. In following this commitment to Equal Employment Opportunity and because the Government is the benefactor of the Federal funds, it is both against the Urban County Government policy and illegal for the Government to let contracts to companies which knowingly or unknowingly practice discrimination in their employment practices. Violation of the above mentioned ordinances may cause a contract to be canceled and the contractor may be declared ineligible for future consideration.

Please sign this statement in the appropriate space acknowledging that you have read and understand the provisions contained herein. Return this document as part of your application packet.

Bidders

I/We agree to comply with the Civil Rights Laws listed above that govern employment rights of minorities, women, Vietnam veterans, handicapped, and aged persons.

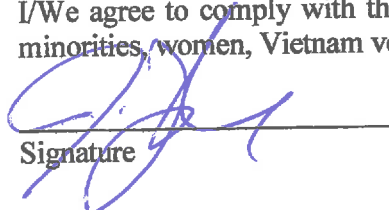
Signature

M3 Technology Group, Inc. dba Multi-Media Masters, Inc.
Name of Business

The Entity (regardless of whether construction contractor, non-construction contractor or supplier) agrees to provide equal opportunity in employment for all qualified persons, to prohibit discrimination in employment because of race, color, creed, national origin, sex or age, and to promote equal employment through a positive, continuing program from itself and each of its sub-contracting agents. This program of equal employment opportunity shall apply to every aspect of its employment policies and practices.

The Kentucky equal Employment Opportunity Act of 1978 (KRS 45.560-45.640) requires that any count, city, town, school district, water district, hospital district, or other political subdivision of the state shall include in directly or indirectly publicly funded contracts for supplies, materials, services, or equipment hereinafter entered into the following provisions:

During the performance of this contract, the contractor agrees as follows:

- (1) *The contractor will not discriminate against any employee or applicant for employment because of race, color, religion, sex, age or national origin;*
- (2) *The contractor will state in all solicitations or advertisements for employees placed by or on behalf of the contractors that all qualified applicants will receive consideration for employment without regard to race, color, religion, sex, age or national origin;*
- (3) *The contract will post notices in conspicuous places, available to employees and applicants for employment, setting forth the provisions of the non-discrimination clauses required by this section; and*
- (4) *The contractor will send a notice to each labor union or representative of workers with which he has a collective bargaining agreement or other contract or understanding advising the labor union or workers' representative of the contractor's commitments under the nondiscrimination clauses.*

The Act further provides:

KRS 45.610. Hiring minorities – Information required

- (1) *For the length of the contract, each contractor shall hire minorities from other sources within the drawing area, should the union with which he has collective bargaining agreements be unwilling to supply sufficient minorities to satisfy the agreed upon goals and timetable.*
- (2) *Each contractor shall, for the length of the contract, furnish such information as required by KRS 45.560 to KRS 45.640 and by such rules, regulations and orders issued pursuant thereto and will permit access to all books and records pertaining to his employment practices and work sites by the contracting agency and the department for purposes of investigation to ascertain compliance with KRS 45.560 to 45.640 and such rules, regulations and orders issued pursuant thereto.*

KRS 45.620. Action against contractor – Hiring of minority contractor or subcontractor

- (1) *If any contractor is found by the department to have engaged in an unlawful practice under this chapter during the course of performing under a contract or subcontract covered under KRS 45.560 to 45.640, the department shall so certify to the contracting agency and such certification shall be binding upon the contracting agency unless it is reversed in the course of judicial review.*
- (2) *If the contractor is found to have committed an unlawful practice under KRS 45.560 to 45.640, the contracting agency may cancel or terminate the contract, conditioned upon a program for future compliance approved by the contracting agency and the department. The contracting agency may declare such a contractor ineligible to bid on further contracts with that agency until such time as the contractor complies in full with the requirements of KRS 45.560 – 45.640.*
- (3) *The equal employment provisions of KRS 45.560 to 45.640 may be met in part by a contractor by subcontracting to a minority contractor or subcontractor. For the provisions of KRS 45.560 to 45.640, a minority contractor or subcontractor shall mean a business that is owned and controlled by one or more persons disadvantaged by racial or ethnic circumstances.*

KRS 45.630 Termination of existing employee not required, when

Any provision of KRS 45.560 to 45.640 notwithstanding, no contractor shall be required to terminate an existing employee upon proof that that employee was employed prior to the date of the contract.

KRS 45.640 Minimum skills

Nothing in KRS 45.560 to 45.640 shall require a contractor to hire anyone who fails to demonstrate the minimum skills required to perform a particular job.

It is recommended that all of the provisions quoted above to be included as special conditions in each contract. In the case of a contract exceeding \$250,000, the contractor is required to furnish evidence that his work-force in Kentucky is representative of the available work-force in the area from which he draws employees, or to supply an Affirmative Action plan which will achieve such representation during the life of the contract.

11. EQUAL EMPLOYMENT OPPORTUNITY AFFIRMATIVE ACTION POLICY

It is the policy of M3 Technology Group, Inc. dba Multi-Media Masters, Inc.

to assure that all applicants for employment and all employees are treated on a fair and equitable basis without regard to their race, religion, sex, color, handicap, natural origin or age.

Such action shall include employment, promotion, demotion, recruitment or recruitment advertising, layoff or termination, rates of pay and other forms of compensation, and selection for training, whether apprenticeship and/or on-the-job-training.

Furthermore, this company agrees to make special recruitment efforts to hire the protected class whenever feasible. This company also agrees to adhere to all applicable federal, state, and local laws relating to Equal Employment Opportunity for all individuals.

12. WORKFORCE ANALYSIS FORM

Name of Organization: **M3 Technology Group, Inc. dba Multi-Media Masters, Inc.** Date: **12 / 22 / 2015**

Categories	Total	White		Black		Other		Total	
		M	F	M	F	M	F	M	F
Administrators	13	11	2					11	2
Professionals /Management	8	7		1				7	1
Superintendents									
Supervisors	6	6						6	
Foremen									
Technicians	15	14			1			15	
Protective Service									
Para-Professionals									
Office/Clerical	8	3	5					3	5
Skilled Craft									
Service/Maintenance	2	1			1			2	
Total:	52	42		8	2			44	8

Prepared By: Deborah Otto, CPA

13. EVIDENCE OF INSURABILITY

LEXINGTON-FAYETTE URBAN COUNTY GOVERNMENT CONSTRUCTION PROJECT
(Use separate form for each Agency or Brokerage agreeing to provide coverage)

Names Insured: M3 Technology Group, Inc. dba Multi-Media Masters, Inc. Employee ID: 01-0547889
 Address: 925 Airport Center Drive Nashville, TN 37217 Phone: 615-227-0717

Project to be insured: AudioVisual Systems for Lexington PSOC

In lieu of obtaining certificates of insurance at this time, the undersigned agrees to provide the above Named Insured with the minimum coverage listed below. These are outlined in the Insurance and Risk Management of Part V (Special Conditions), including all requirements, and conditions:

Section Items	Coverage	Minimum Limits and Policy Requirements	Limits Provided To Insured	Name of Insurer	A.M. Best's Code	Rating
SC-3, Section 2, Part 4.1 - see provisions	CGL	\$1,000,000 per occ. And \$2,000,000 aggregate	\$ 1,000,000.00 per occ and \$2,000,000.00 aggregate	Nationwide Property & Casualty	37877	A+Superior
SC-3, Section 2, Part 4.1 - see provisions	AUTO	\$2,000,000/per occ.	\$ 1,000,000.00 per occ	Nationwide Property & Casualty	37877	A+Superior
SC-3, Section 2, Part 4.1 - see provisions	WC	Statutory w /endorsement as noted	\$10,000,000.00 Umbrella \$ 1,000,000.00	Nationwide Property & Casualty	37877	A+Superior

Section 2 includes required provisions, statements regarding insurance requirements, and the undersigned agrees to abide by all provisions for the coverage's checked above unless stated otherwise when submitting.

Pigg Insurance Agency
 Agency or Brokerage
 120 Anderson Lane
 Street Address
 Hendersonville TN 37075
 City State Zip
 615-822-1989
 Telephone Number

R Gary Pigg
 Name of Authorized Representative
 Agency Owner
R Gary Pigg
 Authorized Signature
 12/28/15
 Date

NOTE: Authorized signatures may be the agent's if agent has placed insurance through an agency agreement with the insurer. If insurance is brokered, authorized signature must be that of authorized representative of insurer.

IMPORTANT: Contract may not be awarded if a completed and signed copy of this form for all coverage's listed above is not provided with the bid.

14. DEBARRED FIRMS

PROJECT NAME: AudioVisual Systems for Lexington PSOC

BID NUMBER: Bid No. 189-2015

**LEXINGTON-FAYETTE URBAN COUNTY GOVERNMENT
LEXINGTON, KY**

All prime Contractors shall certify that Subcontractors have not and will not be awarded to any firms that has been debarred for noncompliance with the Federal Labor Standards, Title VI of the Civil Rights Act of 1964 As Amended, Executive Order 11246 As Amended or any other Federal Law.

All bidders shall complete the attached certification in duplicate and submit both copies to the Owner with the bid proposal. The Owner (grantee) shall transmit one copy to the Lexington-Fayette Urban County Government, Division of Community Development, within fourteen (14) days after bid opening.

The undersigned hereby certifies that the firm of M3 Technology Group, Inc. dba Multi-Media Masters, Inc. has not and will not award a subcontract, in connection with any contract award to it as the result of this bid, to any firm that has been debarred for noncompliance with the Federal labor Standards, Title VI of the civil Rights Act of 1964, Executive Order 11246 as amended or any Federal Law.

M3 Technology Group, Inc. dba Multi-Media Masters, Inc.
Name of Firm Submitting Bid



Signature of Authorized Official

CEO

Title

December 29, 2015

Date

15. DEBARMENT CERTIFICATION

All contractors/subcontractors shall complete the following certification and submit it with the bid proposal.

The contractor/subcontractor certifies in accordance with Executive Order 12549 (Debarment and Suspension 2/18/86) that to the best of its knowledge and belief, that it and its principals:

- 1) Are not presently debarred, suspended, proposed for debarment, declared negligible, or voluntarily excluded from covered transactions or contract by any Federal department or agency for noncompliance with the Federal Labor Standards, Title VI of the Civil Rights Act of 1964 as amended, Executive Order 11246 as amended or any other Federal law;
 - a) Have not within a three year period preceding this proposal been convicted of or had a civil judgment rendered against them for commission of fraud or a criminal offense in connection with obtaining, attempting to obtain, or performing a public (Federal, State or local) transaction or contract under a public transaction; violation of Federal or State antitrust statutes or commission of embezzlement, theft, forgery, bribery, falsification or destruction of records, making false statements, or receiving stolen property;
 - b) Are not presently indicted for or otherwise criminally or civilly charged by a government entity (Federal, State or local) with commission of any of the offenses enumerated in paragraph (1)(a) of this certification; and
 - c) Have not within a three year period preceding this bid has one or more public (Federal, State or local) transactions or contracts terminated for cause or default.

- 2) Where the contractor is unable to certify to any of the statements in this certification, such prospective contractors shall attach an explanation to this certification form.

Firm Name: M3 Technology Group, Inc. dba Multi-Media Masters, Inc.

Project: AudioVisual Systems for Lexington PSOC

Printed Name and Title of Authorized Representative: Jason Taylor, CEO

Signature:  _____

Date: December 29, 2015

END OF SECTION



M3 Technology Group, Inc. (Nashville)
 925 Airpark Center Drive
 Nashville, TN, 37217
 Phone: (615) 227-0717
 Web: m3techgroup.com

Quote

Order No.: **QT-152653**
 Quoted Date: Dec-28-2015
 Delivery Date:
 Quote Expires: Jan-27-2016
 Your Customer #: CUST101644

BILL TO:	SHIP TO:
Lexington-Fayette Urban County Government Attn: Division of Purchasing 200 East Main Street 3rd Floor, Room 338 Lexington KY 40507	Lexington-Fayette Urban County Government Attn: Division of Purchasing 200 East Main Street 3rd Floor, Room 338 Lexington KY 40507

CUSTOMER P.O. NO.	TERMS	CONTACT
	To Be Determined	Rebecca Betts - Collin McGinley

Job/Room Reference	SHIPPING TERMS	SHIP VIA
Bid No. 189-2015	Quoted (line item)	UPS Ground

NO.	ITEM	QTY.	PRICE	EXTENDED PRICE
LexCall 311-Room 112				
1	NECE585: E585 - 58" LED LCD Public Display Monitor w/built in ATSC tuner, 1920x1080 (FHD) native resolution, RS-232 control, Full AV function, USB Player. Built in speakers. 3 Year Warranty	3.00	1,370.00	4,110.00
2	CHFTS318TU: Medium THINSTALL Dual Swing Arm Wall Display Mount - 18" Extension	3.00	223.00	669.00
3	CREDMRMCSCALERC: Crestron DigitalMedia 8G+™ Receiver & Room Controller w/Scaler	1.00	769.00	769.00
4	COVHD2806M: 6FT HDMI CABLE M-M	1.00	10.00	10.00
5	MIDPD215: 15A Power Distribution With Mov Surge Protection. 2 Outlets, Led Surge Status And Power On Status. Iec	3.00	98.00	294.00
6	MISCELLANEOUS: Cables, Connectors, Hardware, Etc.	1.00	772.00	772.00
7	INSTALLATION: Labor to Install	1.00	1,600.00	1,600.00
8	PROGRAMMINGTN: System Programming	1.00	125.00	125.00
9	SHIPPING: Shipping	1.00	45.00	45.00
9	M3-1YR: 1 Year Maintenance Contract	1.00	587.58	587.58
9	MISCELLANEOUS: P&P Bid Bond	1.00	408.77	408.77
LexCall 311-Room 115				
10	INFINF5720KIT: Mondopad - Multi-touch 57-inch Collab Display Kit with Sound bar and Table Stand	1.00	6,119.00	6,119.00
11	CHFPNRUB: Articulating Arm Wall Mount with 25" Extension	1.00	507.00	507.00
12	MIDPD215: 15A Power Distribution With Mov Surge Protection. 2 Outlets, Led Surge Status And Power On Status. Iec	1.00	98.00	98.00
13	COVHD2810M: 10ft 28 Awg HDMI Cable	1.00	14.00	14.00
14	MISCELLANEOUS: Cables, Connectors, Hardware, Etc.	1.00	115.00	115.00
15	INSTALLATION: Labor to Install	1.00	400.00	400.00
16	SHIPPING: Shipping	1.00	190.00	190.00
16	M3-1YR: 1 Year Maintenance Contract	1.00	493.01	493.01
16	MISCELLANEOUS: P&P Bid Bond	1.00	408.77	408.77
LexCall Offices-Rooms 113 and 114				
17	SONKDL40W600B: 40" 1080p LED Smart HDTV	2.00	458.00	916.00

Continued...



M3 Technology Group, Inc. (Nashville)
 925 Airpark Center Drive
 Nashville, TN, 37217
 Phone: (615) 227-0717
 Web: m3techgroup.com

Quote

Order No.: **QT-152653**
 Quoted Date: Dec-28-2015
 Delivery Date:
 Quote Expires: Jan-27-2016
 Your Customer #: CUST101644

BILL TO:	SHIP TO:
Lexington-Fayette Urban County Government Attn: Division of Purchasing 200 East Main Street 3rd Floor, Room 338 Lexington KY 40507	Lexington-Fayette Urban County Government Attn: Division of Purchasing 200 East Main Street 3rd Floor, Room 338 Lexington KY 40507

CUSTOMER P.O. NO.	TERMS	CONTACT
	To Be Determined	Rebecca Betts - Collin McGinley

Job/Room Reference	SHIPPING TERMS	SHIP VIA
Bid No. 189-2015	Quoted (line item)	UPS Ground

NO.	ITEM	QTY.	PRICE	EXTENDED PRICE
18	CHFTS318TU: Medium THINSTALL Dual Swing Arm Wall Display Mount - 18" Extension	2.00	223.00	446.00
19	MIDPD215: 15A Power Distribution With Mov Surge Protection. 2 Outlets, Led Surge Status And Power On Status. Iec	2.00	98.00	196.00
20	MISCELLANEOUS: Cables, Connectors, Hardware, Etc.	1.00	252.00	252.00
21	INSTALLATION: Labor to Install	1.00	800.00	800.00
22	SHIPPING: Shipping	1.00	45.00	45.00
22	M3-1YR: 1 Year Maintenance Contract	1.00	185.85	185.85
22	MISCELLANEOUS: P&P Bid Bond	1.00	408.77	408.77
EMA Offices-Rooms 106,107,108 and 109				
23	SONKDL40W600B: 40" 1080p LED Smart HDTV	5.00	458.00	2,290.00
24	CHFTS318TU: Medium THINSTALL Dual Swing Arm Wall Display Mount - 18" Extension	5.00	223.00	1,115.00
25	MIDPD215: 15A Power Distribution With Mov Surge Protection. 2 Outlets, Led Surge Status And Power On Status. Iec	5.00	98.00	490.00
26	CREDMRMCSCALERC: Crestron DigitalMedia 8G+™ Receiver & Room Controller w/Scaler	1.00	769.00	769.00
27	COVHD2806M: 6FT HDMI CABLE M-M	1.00	10.00	10.00
28	MISCELLANEOUS: Cables, Connectors, Hardware, Etc.	1.00	542.34	542.34
29	INSTALLATION: Labor to Install	1.00	1,000.00	1,000.00
30	PROGRAMMINGTN: System Programming	1.00	125.00	125.00
31	SHIPPING: Shipping	1.00	190.00	190.00
31	M3-1YR: 1 Year Maintenance Contract	1.00	458.85	458.85
31	MISCELLANEOUS: P&P Bid Bond	1.00	408.77	408.77
Room 120-Large Breakroom				
32	LGE55LF6100: 55" 1080p LED Smart HDTV	1.00	682.00	682.00
33	CHFTS318TU: Medium THINSTALL Dual Swing Arm Wall Display Mount - 18" Extension	1.00	223.00	223.00
34	MIDPD215: 15A Power Distribution With Mov Surge Protection. 2 Outlets, Led Surge Status And Power On Status. Iec	1.00	98.00	98.00
35	MISCELLANEOUS: Cables, Connectors, Hardware, Etc.	1.00	126.00	126.00

Continued...



M3 Technology Group, Inc. (Nashville)
 925 Airpark Center Drive
 Nashville, TN, 37217
 Phone: (615) 227-0717
 Web: m3techgroup.com

Quote

Order No.: QT-152653
 Quoted Date: Dec-28-2015
 Delivery Date:
 Quote Expires: Jan-27-2016
 Your Customer #: CUST101644

BILL TO:	SHIP TO:
Lexington-Fayette Urban County Government Attn: Division of Purchasing 200 East Main Street 3rd Floor, Room 338 Lexington KY 40507	Lexington-Fayette Urban County Government Attn: Division of Purchasing 200 East Main Street 3rd Floor, Room 338 Lexington KY 40507

CUSTOMER P.O. NO.	TERMS	CONTACT
	To Be Determined	Rebecca Betts - Collin McGinley

Job/Room Reference	SHIPPING TERMS	SHIP VIA
Bid No. 189-2015	Quoted (line item)	UPS Ground

NO.	ITEM	QTY.	PRICE	EXTENDED PRICE
36	INSTALLATION: Labor to Install	1.00	600.00	600.00
37	SHIPPING: Shipping	1.00	35.00	35.00
37	M3-1YR: 1 Year Maintenance Contract	1.00	123.48	123.48
37	MISCELLANEOUS: P&P Bid Bond	1.00	408.77	408.77
38	M3-1YR: 1 Year Maintenance Contract	1.00	20.98	20.98
38	MISCELLANEOUS: P&P Bid Bond	1.00	408.77	408.77
9-1-1 Administrative Office-Room 153				
38	MISCELLANEOUS: (no-TV) Run RG-6 Quad Shielded Plenum Rated cable to contractor furnished wall box	1.00	299.00	299.00
9-1-1 Training Room -Room 144				
39	INF8021KIT: 80-INCH TOUCHSCREEN COLLABORATION SOLUTION	1.00	16,236.00	16,236.00
40	CHFPDRUB: Large Dual Arm W/ Universal Mount	1.00	582.00	582.00
41	MIDPD215: 15A Power Distribution With Mov Surge Protection. 2 Outlets, Led Surge Status And Power On Status. Iec	1.00	98.00	98.00
42	COVHD2425M: 25ft 24AWG HDMI Cable M-M	1.00	40.00	40.00
43	MISCELLANEOUS: Cables, Connectors, Hardware, Etc.	1.00	99.00	99.00
44	COVHD2815M: 15ft 28 Gauge HDMI Cable	1.00	18.00	18.00
45	MISCELLANEOUS: HDMI Wall Plate-Color/Finish TBD	1.00	30.00	30.00
46	INSTALLATION: Labor to Install	1.00	600.00	600.00
47	SHIPPING: Shipping	1.00	305.00	305.00
47	M3-1YR: 1 Year Maintenance Contract	1.00	1,260.56	1,260.56
47	MISCELLANEOUS: P&P Bid Bond	1.00	408.77	408.77
ESF 2 Room-Room 124				
48	LGE55LF6100: 55" 1080p LED Smart HDTV	1.00	682.00	682.00
49	CHFTS318TU: Medium THINSTALL Dual Swing Arm Wall Display Mount - 18" Extension	1.00	223.00	223.00
50	MIDPD215: 15A Power Distribution With Mov Surge Protection. 2 Outlets, Led Surge Status And Power On Status. Iec	1.00	98.00	98.00
51	CREDMRMCSALERC: Crestron DigitalMedia 8G+™ Receiver & Room Controller w/Scaler	1.00	769.00	769.00
52	COVHD2806M: 6FT HDMI CABLE M-M	1.00	10.00	10.00

Continued...



M3 Technology Group, Inc. (Nashville)
 925 Airpark Center Drive
 Nashville, TN, 37217
 Phone: (615) 227-0717
 Web: m3techgroup.com

Quote

Order No.: QT-152653
 Quoted Date: Dec-28-2015
 Delivery Date:
 Quote Expires: Jan-27-2016
 Your Customer #: CUST101644

BILL TO:	SHIP TO:
Lexington-Fayette Urban County Government Attn: Division of Purchasing 200 East Main Street 3rd Floor, Room 338 Lexington KY 40507	Lexington-Fayette Urban County Government Attn: Division of Purchasing 200 East Main Street 3rd Floor, Room 338 Lexington KY 40507

CUSTOMER P.O. NO.	TERMS	CONTACT
	To Be Determined	Rebecca Betts - Collin McGinley

Job/Room Reference	SHIPPING TERMS	SHIP VIA
Bid No. 189-2015	Quoted (line item)	UPS Ground

NO.	ITEM	QTY.	PRICE	EXTENDED PRICE
53	MISCELLANEOUS: Cables, Connectors, Hardware, Etc.	1.00	206.00	206.00
54	INSTALLATION: Labor to Install	1.00	600.00	600.00
55	PROGRAMMINGTN: System Programming	1.00	125.00	125.00
56	SHIPPING: Shipping	1.00	50.00	50.00
56	M3-1YR: 1 Year Maintenance Contract	1.00	193.41	193.41
56	MISCELLANEOUS: P&P Bid Bond	1.00	408.77	408.77
Breakout Rooms-125,126,130 and 131				
57	INFINF7021KIT: 70-INCH TOUCH SOLUTION	4.00	9,295.00	37,180.00
58	CHFPDRUB: Large Dual Arm W/ Universal	4.00	582.00	2,328.00
59	MIDPD215: 15A Power Distribution With Mov Surge Protection. 2 Outlets, Led Surge Status And Power On Status. Iec	4.00	98.00	392.00
60	CREDMTX201C: DigitalMedia 8G+™ Transmitter 201	8.00	732.00	5,856.00
61	COVHD2810M: 10ft 28 Awg HDMI Cable	1.00	14.00	14.00
62	CREDMRMCSCALERC: Crestron DigitalMedia 8G+™ Receiver & Room Controller w/Scaler	4.00	769.00	3,076.00
63	COVHD2806M: 6FT HDMI CABLE M-M	4.00	10.00	40.00
64	MISCELLANEOUS: Cables, Connectors, Hardware, Etc.	1.00	1,080.00	1,080.00
65	INSTALLATION: Labor to Install	1.00	2,600.00	2,600.00
66	PROGRAMMINGTN: System Programming	1.00	1,500.00	1,500.00
67	SHIPPING: Shipping	1.00	990.00	990.00
67	M3-1YR: 1 Year Maintenance Contract	1.00	3,853.92	3,853.92
67	MISCELLANEOUS: P&P Bid Bond	1.00	408.77	408.77
Policy Room-Room 127				
68	NECE905AVT: 90 inch LED LCD monitor with tuner	1.00	8,790.00	8,790.00
69	CHFPDRUB: Large Dual Arm W/ Universal	1.00	582.00	582.00
70	NECE585: E585 - 58" LED LCD Public Display Monitor w/built in ATSC tuner, 1920x1080 (FHD) native resolution, RS-232 control, Full AV function, USB Player. Built in speakers. 3 Year Warranty	2.00	1,370.00	2,740.00
71	CHFTS318TU: Medium THINSTALL Dual Swing Arm Wall Display Mount - 18" Extension	2.00	223.00	446.00

Continued...



M3 Technology Group, Inc. (Nashville)
 925 Airpark Center Drive
 Nashville, TN, 37217
 Phone: (615) 227-0717
 Web: m3techgroup.com

Quote

Order No.: QT-152653
Quoted Date: Dec-28-2015
Delivery Date:
Quote Expires: Jan-27-2016
Your Customer #: CUST101644

BILL TO:	SHIP TO:
Lexington-Fayette Urban County Government Attn: Division of Purchasing 200 East Main Street 3rd Floor, Room 338 Lexington KY 40507	Lexington-Fayette Urban County Government Attn: Division of Purchasing 200 East Main Street 3rd Floor, Room 338 Lexington KY 40507

CUSTOMER P.O. NO.	TERMS	CONTACT
	To Be Determined	Rebecca Betts - Collin McGinley

Job/Room Reference	SHIPPING TERMS	SHIP VIA
Bid No. 189-2015	Quoted (line item)	UPS Ground

NO.	ITEM	QTY.	PRICE	EXTENDED PRICE
72	MIDPD215: 15A Power Distribution With Mov Surge Protection. 2 Outlets, Led Surge Status And Power On Status. Iec	3.00	98.00	294.00
73	CREDMRMCSALERC: Crestron DigitalMedia 8G+™ Receiver & Room Controller w/Scaler	3.00	769.00	2,307.00
74	COVHD2806M: 6FT HDMI CABLE M-M	3.00	10.00	30.00
75	CREDMTX201C: DigitalMedia 8G+™ Transmitter 201	2.00	732.00	1,464.00
76	COVHD2810M: 10ft 28 Awg HDMI Cable	2.00	14.00	28.00
77	LABE42: 2x200w amplifier	1.00	554.00	554.00
78	COMD4: DIST DESIGN 4.5-INCH CEILING SPEAKER STANDARD	8.00	113.00	904.00
80	AUDMTU301: Bodypack Transmitter	2.00	796.00	1,592.00
81	AUDAT831CW: Cardioid Condenser Lavalier Microphone	2.00	93.00	186.00
82	AUDCHG001: Wall Charger for MTU301	2.00	63.00	126.00
83	MISCELLANEOUS: Cables, Connectors, Hardware, Etc.	1.00	749.00	749.00
84	INSTALLATION: Labor to Install	1.00	2,400.00	2,400.00
85	PROGRAMMINGTN: System Programming	1.00	625.00	625.00
86	SHIPPING: Shipping	1.00	440.00	440.00
86	M3-1YR: 1 Year Maintenance Contract	1.00	1,697.99	1,697.99
86	MISCELLANEOUS: P&P Bid Bond	1.00	408.77	408.77
EOC-Room 129				
87	NECE905AVT: 90 inch LED LCD monitor with tuner	3.00	8,790.00	26,370.00
88	CHFPDRUB: Large Dual Arm W/ Universal	3.00	582.00	1,746.00
89	NECE585: E585 - 58" LED LCD Public Display Monitor w/built in ATSC tuner, 1920x1080 (FHD) native resolution, RS-232 control, Full AV function, USB Player. Built in speakers. 3 Year Warrantv	4.00	1,370.00	5,480.00
90	CHFTS318TU: Medium THINSTALL Dual Swing Arm Wall Display Mount - 18" Extension	4.00	223.00	892.00
91	MIDPD215: 15A Power Distribution With Mov Surge Protection. 2 Outlets, Led Surge Status And Power On Status. Iec	7.00	98.00	686.00
92	CREDMRMCSALERC: Crestron DigitalMedia 8G+™ Receiver & Room Controller w/Scaler	7.00	769.00	5,383.00
93	COVHD2806M: 6FT HDMI CABLE M-M	7.00	10.00	70.00

Continued...



M3 Technology Group, Inc. (Nashville)
 925 Airpark Center Drive
 Nashville, TN, 37217
 Phone: (615) 227-0717
 Web: m3techgroup.com

Quote

Order No.: **QT-152653**
 Quoted Date: Dec-28-2015
 Delivery Date:
 Quote Expires: Jan-27-2016
 Your Customer #: CUST101644

BILL TO:	SHIP TO:
Lexington-Fayette Urban County Government Attn: Division of Purchasing 200 East Main Street 3rd Floor, Room 338 Lexington KY 40507	Lexington-Fayette Urban County Government Attn: Division of Purchasing 200 East Main Street 3rd Floor, Room 338 Lexington KY 40507

CUSTOMER P.O. NO.	TERMS	CONTACT
	To Be Determined	Rebecca Betts - Collin McGinley

Job/Room Reference	SHIPPING TERMS	SHIP VIA
Bid No. 189-2015	Quoted (line item)	UPS Ground

NO.	ITEM	QTY.	PRICE	EXTENDED PRICE
94	CREDMTX201C: DigitalMedia 8G+™ Transmitter 201	13.00	732.00	9,516.00
95	COVHD2810M: 10ft 28 Awg HDMI Cable	10.00	14.00	140.00
96	LABE42: 2x200w amplifier	2.00	554.00	1,108.00
97	COMD4: DIST DESIGN 4.5-INCH CEILING SPEAKER STANDARD	20.00	113.00	2,260.00
98	AUDACI707: Audio Control Interface (7 Channel)	1.00	1,725.00	1,725.00
99	AUDRCUDRM4: Receiver Coordinator Unit and 4 DRM141 Package	1.00	11,964.00	11,964.00
100	AUDMTU301: Bodypack Transmitter	5.00	796.00	3,980.00
101	AUDAT831CW: Cardioid Condenser Lavalier Microphone	5.00	93.00	465.00
102	AUDCHG001: Wall Charger for MTU301	5.00	63.00	315.00
102	AUDSEP128: *OPTION* Software Encryption Package AES 128-Bit	1.00	1,098.00	1,098.00
103		2.00	2,255.00	4,510.00
	BIATESIRAFORTEAVBCI: TesiraFORTE DSP fixed I/O server with 12 analog inputs, 8 analog outputs, 8 channels configurable USB audio, 128 x 128 channels of AVB, and Sona™ Acoustic Echo Cancellation (AEC) technology (all 12 inputs)			
104	MISCELLANEOUS: MOTU AVB Switch	1.00	450.00	450.00
105	MISCELLANEOUS: Cables, Connectors, Hardware, Etc.	1.00	1,263.00	1,263.00
106	INSTALLATION: Labor to Install	1.00	4,000.00	4,000.00
107	PROGRAMMINGTN: System Programming	1.00	4,250.00	4,250.00
108	SHIPPING: Shipping	1.00	826.60	826.60
108	M3-1YR: 1 Year Maintenance Contract	1.00	6,205.22	6,205.22
108	MISCELLANEOUS: P&P Bid Bond	1.00	408.77	408.77
Breakout Rooms-125,126,130 and 131 (Wireless Microphone Systems)				
109	AUDACI707: Audio Control Interface (7 Channel)	1.00	1,725.00	1,725.00
110	AUDMTU301: Bodypack Transmitter	2.00	796.00	1,592.00
111	AUDAT831CW: Cardioid Condenser Lavalier Microphone	2.00	93.00	186.00
112	AUDCHG001: Wall Charger for MTU301	2.00	63.00	126.00
113	AUDRCUDRM4: Receiver Coordinator Unit and 4 DRM141 Package	1.00	11,964.00	11,964.00
113	AUDSEP128: *OPTION* Software Encryption Package AES 128-Bit	1.00	1,098.00	1,098.00
113	M3-1YR: 1 Year Maintenance Contract	1.00	1,168.37	1,168.37
113	MISCELLANEOUS: P&P Bid Bond	1.00	408.77	408.77

Continued...



M3 Technology Group, Inc. (Nashville)
 925 Airpark Center Drive
 Nashville, TN, 37217
 Phone: (615) 227-0717
 Web: m3techgroup.com

Quote

Order No.: QT-152653
 Quoted Date: Dec-28-2015
 Delivery Date:
 Quote Expires: Jan-27-2016
 Your Customer #: CUST101644

BILL TO:	SHIP TO:
Lexington-Fayette Urban County Government Attn: Division of Purchasing 200 East Main Street 3rd Floor, Room 338 Lexington KY 40507	Lexington-Fayette Urban County Government Attn: Division of Purchasing 200 East Main Street 3rd Floor, Room 338 Lexington KY 40507

CUSTOMER P.O. NO.	TERMS	CONTACT
	To Be Determined	Rebecca Betts - Collin McGinley

Job/Room Reference	SHIPPING TERMS	SHIP VIA
Bid No. 189-2015	Quoted (line item)	UPS Ground

NO.	ITEM	QTY.	PRICE	EXTENDED PRICE
JIC-Room 123				
114	LGE55LF6100: 55" 1080p LED Smart HDTV	4.00	682.00	2,728.00
115	CHFTS318TU: Medium THINSTALL Dual Swing Arm Wall Display Mount - 18" Extension	4.00	223.00	892.00
116	MIDPD215: 15A Power Distribution With Mov Surge Protection. 2 Outlets, Led Surge Status And Power On Status. Iec	4.00	98.00	392.00
117	CREDMRMCSCALERC: Crestron DigitalMedia 8G+™ Receiver & Room Controller w/Scaler	4.00	769.00	3,076.00
118	COVHD2806M: 6FT HDMI CABLE M-M	4.00	10.00	40.00
119	CREDMMD6X6: 6x6 DigitalMedia™ Distribution Center	1.00	3,049.00	3,049.00
120	COVHD2425M: 25ft 24AWG HDMI Cable M-M	4.00	40.00	160.00
121	MISCELLANEOUS: HDMI Wall Plate	1.00	30.00	30.00
121	MIDPD915RC20: 9 Outlet, Single 15 Amp Circuit, Surge/Spike Protected Rackmount Power Distribution W/20' Cord, Black Powdercoat Finish	1.00	87.00	87.00
122	CREDMRMC100C: DigitalMedia 8G+™ Receiver & Room Controller 100	1.00	675.00	675.00
123	CRETSW1052BS: 10.1" Touch Screen, Black Smooth	1.00	1,350.00	1,350.00
124	CREPWE4803RU: PoE Injector, universal 100-250 Volts AC	1.00	67.00	67.00
125	CRECP3: 3-Series Control System®	1.00	1,099.00	1,099.00
126	MISCELLANEOUS: Network Switch for Crestron System	1.00	250.00	250.00
126	MIDVT3: 3 Space (5 1/4") Vent Panel, 64% Open Area	1.00	16.00	16.00
127	MISCELLANEOUS: Cables, Connectors, Hardware, Etc.	1.00	697.00	697.00
128	INSTALLATION: Labor to Install	1.00	1,800.00	1,800.00
129	PROGRAMMINGTN: System Programming	1.00	1,000.00	1,000.00
130	SHIPPING: Shipping	1.00	380.00	380.00
130	M3-1YR: 1 Year Maintenance Contract	1.00	1,245.16	1,245.16
130	MISCELLANEOUS: P&P Bid Bond	1.00	408.77	408.77
Master Control System				
131	CREPRO3: 3-Series Control System®	1.00	2,982.00	2,982.00
132	MISCELLANEOUS: Network Switch for Crestron System	1.00	385.00	385.00
133	CREPWE4803RU: PoE Injector, universal 100-250 Volts AC	2.00	67.00	134.00

Continued...



M3 Technology Group, Inc. (Nashville)
 925 Airpark Center Drive
 Nashville, TN, 37217
 Phone: (615) 227-0717
 Web: m3techgroup.com

Quote

Order No.: QT-152853
 Quoted Date: Dec-28-2015
 Delivery Date:
 Quote Expires: Jan-27-2016
 Your Customer #: CUST101644

BILL TO:	SHIP TO:
Lexington-Fayette Urban County Government Attn: Division of Purchasing 200 East Main Street 3rd Floor, Room 338 Lexington KY 40507	Lexington-Fayette Urban County Government Attn: Division of Purchasing 200 East Main Street 3rd Floor, Room 338 Lexington KY 40507

CUSTOMER P.O. NO.	TERMS	CONTACT
	To Be Determined	Rebecca Betts - Collin McGinley

Job/Room Reference	SHIPPING TERMS	SHIP VIA
Bid No. 189-2015	Quoted (line item)	UPS Ground

NO.	ITEM	QTY.	PRICE	EXTENDED PRICE
134	CRECENRFGWEX: Crestron infINET EX® Wireless Gateway	1.00	254.00	254.00
135	CRETSW1052BS: 10.1" Touch Screen, Black Smooth (Room 127)	1.00	1,350.00	1,350.00
136	CRETST902: 8.7" Wireless Touch Screen (Room 129)	2.00	2,138.00	4,276.00
137	CRETST902DSWB: Wall Mount Back Box for TST-902-DSW	2.00	113.00	226.00
138	MISCELLANEOUS: Cables, Connectors, Hardware, Etc.	1.00	210.00	210.00
139	INSTALLATION: Labor to Install	1.00	1,400.00	1,400.00
140	PROGRAMMINGTN: System Programming	1.00	4,000.00	4,000.00
141	SHIPPING: Shipping	1.00	180.00	180.00
141	M3-1YR: 1 Year Maintenance Contract	1.00	1,077.79	1,077.79
141	MISCELLANEOUS: P&P Bid Bond	1.00	408.77	408.77
Crestron Master DM 32x32 Matrix Chassis and I/O Cards				
142	CREDMMD32X32RPS: 32x32 DigitalMedia™ Switcher w/Redundant Power Supply	1.00	10,350.00	10,350.00
143	CREDMCC: DigitalMedia 8G+™ Input Card for DM® Switchers	24.00	338.00	8,112.00
144	CREDMCDVI: DVI/RGB Input Card for DM Switchers	6.00	450.00	2,700.00
145	CREDMC4KCOHD: 2-Channel 4K DigitalMedia 8G+™ Output Card for DM® Switchers	10.00	732.00	7,320.00
146	CREDMCHDO: 2-Channel HDMI Output Card for DM Switchers	2.00	394.00	788.00
146	MIDPD915RC20: 9 Outlet, Single 15 Amp Circuit, Surge/Spike Protected Rackmount Power Distribution W/20' Cord, Black Powdercoat Finish	1.00	87.00	87.00
147	MISCELLANEOUS: Cables, Connectors, Hardware, Etc.	1.00	75.00	75.00
147	MIDVT3: 3 Space (5 1/4") Vent Panel, 64% Open Area	1.00	16.00	16.00
148	INSTALLATION: Labor to Install	1.00	200.00	200.00
149	PROGRAMMINGTN: System Programming	1.00	4,000.00	4,000.00
150	SHIPPING: Shipping	1.00	110.00	110.00
150	M3-1YR: 1 Year Maintenance Contract	1.00	2,363.06	2,363.06
150	MISCELLANEOUS: P&P Bid Bond	1.00	480.77	480.77
CATV Modulation and Distribution System				
151	EXT6048801: DA2 RGBHV : 2 Output Wideband RGBHV Distribution Amplifier	6.00	403.00	2,418.00

Continued...



M3 Technology Group, Inc. (Nashville)
 925 Airpark Center Drive
 Nashville, TN, 37217
 Phone: (615) 227-0717
 Web: m3techgroup.com

Quote

Order No.: QT-152653
 Quoted Date: Dec-28-2015
 Delivery Date:
 Quote Expires: Jan-27-2016
 Your Customer #: CUST101644

BILL TO:	SHIP TO:
Lexington-Fayette Urban County Government Attn: Division of Purchasing 200 East Main Street 3rd Floor, Room 338 Lexington KY 40507	Lexington-Fayette Urban County Government Attn: Division of Purchasing 200 East Main Street 3rd Floor, Room 338 Lexington KY 40507

CUSTOMER P.O. NO.	TERMS	CONTACT
	To Be Determined	Rebecca Betts - Collin McGinley

Job/Room Reference	SHIPPING TERMS	SHIP VIA
Bid No. 189-2015	Quoted (line item)	UPS Ground

NO.	ITEM	QTY.	PRICE	EXTENDED PRICE
152	EXT6044001: MDA 3A : Three Output Stereo Audio Distribution Amplifier	6.00	142.00	852.00
153	EXT6060402: RSB 129 : 1U 9.5" Deep Basic Rack Shelf	6.00	48.00	288.00
154	EXT10022901: RCA Female to BNC Male Adapter-10 Pack	6.00	18.00	108.00
155	ZEEHDB2640NA: ZeeVee 4 channel HD Modulator	2.00	3,757.00	7,514.00
156	EXT2660901: DVI to 5-BNC Adapter Cable: DVI-A M to Five BNC Fem - 6"	6.00	37.00	222.00
156	MIDPD915RC20: 9 Outlet, Single 15 Amp Circuit, Surge/Spike Protected Rackmount Power Distribution W/20' Cord, Black Powdercoat Finish	2.00	87.00	174.00
157	COVPCVD035506: Cable, (3) RCA, Component Video, 6ft	12.00	37.00	444.00
157	MIDVT3: 3 Space (5 1/4") Vent Panel, 64% Open Area	1.00	16.00	16.00
158	COVPCVD035512: Cable, (3) RCA, Component Video, 12ft	8.00	20.00	160.00
159	MISCELLANEOUS: Cables, Connectors, Hardware, Etc.	1.00	100.00	100.00
160	INSTALLATION: Labor to Install	1.00	600.00	600.00
161	PROGRAMMINGTN: System Programming	1.00	125.00	125.00
162	SHIPPING: Shipping	1.00	345.00	345.00
163	MISCELLANEOUS: Materials Needed to Ground System Components in the main equipment racks	1.00	100.00	100.00
164	INSTALLATION: Installation Labor to Ground All System Components in the Main Equipment Racks	1.00	800.00	800.00
164	M3-1YR: 1 Year Maintenance Contract	1.00	998.62	998.62
164	MISCELLANEOUS: P&P Bid Bond	1.00	408.77	408.77
Press Room-Room 122				
165	VAD9996850000: Sony BRC-Z330 PTZ Camera	3.00	4,348.00	13,044.00
166	VAD9996850110: BRBK-HSD2 -- HD-SDI Output Card	3.00	1,525.00	4,575.00
167	VAD5352000236B: Sony PTZ Camera Thin Wall Mount	3.00	177.00	531.00
168	VAD9996605000: Vaddio/Sony Joystick Control Bundle VISCA PTZ Camera Controller	1.00	1,625.00	1,625.00
169	CREDMPS3300C: 3-Series® DigitalMedia™ Presentation System 300	1.00	4,667.00	4,667.00
170	CRETSW1052BS: 10.1" Touch Screen, Black Smooth	1.00	1,350.00	1,350.00
171	CREPWE4803RU: PoE Injector, universal 100-250 Volts AC	1.00	67.00	67.00

Continued...



M3 Technology Group, Inc. (Nashville)
 925 Airpark Center Drive
 Nashville, TN, 37217
 Phone: (615) 227-0717
 Web: m3techgroup.com

Quote

Order No.: QT-152653
 Quoted Date: Dec-28-2015
 Delivery Date:
 Quote Expires: Jan-27-2016
 Your Customer #: CUST101644

BILL TO:	SHIP TO:
Lexington-Fayette Urban County Government Attn: Division of Purchasing 200 East Main Street 3rd Floor, Room 338 Lexington KY 40507	Lexington-Fayette Urban County Government Attn: Division of Purchasing 200 East Main Street 3rd Floor, Room 338 Lexington KY 40507

CUSTOMER P.O. NO.	TERMS	CONTACT
	To Be Determined	Rebecca Betts - Collin McGinley

Job/Room Reference	SHIPPING TERMS	SHIP VIA
Bid No. 189-2015	Quoted (line item)	UPS Ground

NO.	ITEM	QTY.	PRICE	EXTENDED PRICE
172	CREDMRMCSCALERC: Crestron DigitalMedia 8G+™ Receiver & Room Controller w/Scaler	1.00	769.00	769.00
173	MISCELLANEOUS: HDMI Wall Plate-Color/Finish TBD	1.00	30.00	30.00
174	LABE42: 2x200w amplifier	1.00	554.00	554.00
175	COMD4: DIST DESIGN 4.5-INCH CEILING SPEAKER STANDARD	6.00	113.00	678.00
176	NECE805AVT: 80" LED LCD Public Display Monitor, 1920 x 1080 w/tuner	1.00	5,153.00	5,153.00
177	CHFPDRUB: Large Dual Arm W/ Universal	1.00	582.00	582.00
178	MIDPD215: 15A Power Distribution With Mov Surge Protection. 2 Outlets, Led Surge Status And Power On Status. Iec	1.00	98.00	98.00
179	MIDPD915RC20: 9 Outlet, Single 15 Amp Circuit, Surge/Spike Protected Rackmount Power Distribution W/20' Cord, Black Powdercoat Finish	1.00	87.00	87.00
180	AUDAT831CW: Cardioid Condenser Lavalier Microphone	1.00	93.00	93.00
181	AUDATW1301: Digital Wireless Microphone System-ATW-RC13 rack-mount receiver chassis, ATWRU13 receiver unit and ATW-T1001 UniPak® transmitter. Select a Wireless Essentials® microphone or cable to complete the system.	1.00	412.00	412.00
182	BMDBMDCONVMBHS2: HDMI to SDI Mini Converter-PS Included	1.00	201.00	201.00
183	BMDBMDCONVMSDIDA: 1x8 SDI Distribution Amplifier	1.00	232.00	232.00
184	BMDBMDCONVMCAUDS: Analog Audio to SDI Converter/Embedder	1.00	232.00	232.00
185	EXT6090001: FOX 3G HD-SDI MM : Fiber Optic Extender for 3G-SDI - 850 nm Multimode	2.00	1,244.00	2,488.00
186	EXT6060421: RSB 123 : 1U 3.5" Deep Basic Rack Shelf	1.00	34.00	34.00
187	BMDBMDCONVMCSAUD: SDI to Audio Converter/De-Embedder	1.00	232.00	232.00
188	RDLRUADA4D: Stereo Audio Distribution with 4 Outputs	1.00	260.00	260.00
189	RDLPS24AS: RDL USA Power Supply	1.00	24.00	24.00
190	LIVLSHD550: Studio HD550-Compact and portable all-in-one live production switcher	1.00	8,941.00	8,941.00
191	LIVLSSTUDIOSURFACEGO: Studio Surface Go	1.00	999.00	999.00
192	COVHD2806M: 6FT HDMI CABLE M-M	4.00	10.00	40.00
193	COVHD2810M: 10ft 28 Awg HDMI Cable	2.00	14.00	28.00
194	MISCELLANEOUS: Multi-Connection Custom Wall Plate	1.00	450.00	450.00

Continued...



M3 Technology Group, Inc. (Nashville)
 925 Airpark Center Drive
 Nashville, TN, 37217
 Phone: (615) 227-0717
 Web: m3techgroup.com

Quote

Order No.: QT-152653
 Quoted Date: Dec-28-2015
 Delivery Date:
 Quote Expires: Jan-27-2016
 Your Customer #: CUST101644

BILL TO:	SHIP TO:
Lexington-Fayette Urban County Government Attn: Division of Purchasing 200 East Main Street 3rd Floor, Room 338 Lexington KY 40507	Lexington-Fayette Urban County Government Attn: Division of Purchasing 200 East Main Street 3rd Floor, Room 338 Lexington KY 40507

CUSTOMER P.O. NO.	TERMS	CONTACT
	To Be Determined	Rebecca Betts - Collin McGinley

Job/Room Reference	SHIPPING TERMS	SHIP VIA
Bid No. 189-2015	Quoted (line item)	UPS Ground

NO.	ITEM	QTY.	PRICE	EXTENDED PRICE
195	MISCELLANEOUS: Cables, Connectors, Hardware, Etc.	1.00	550.00	550.00
196	INSTALLATION: Labor to Install	1.00	4,800.00	4,800.00
197	PROGRAMMINGTN: System Programming	1.00	3,000.00	3,000.00
198	SHIPPING: Shipping	1.00	601.00	601.00
198	M3-1YR: 1 Year Maintenance Contract	1.00	4,021.92	4,021.92
198	MISCELLANEOUS: P&P Bid Bond	1.00	408.77	408.77

Should purchaser fail to pay the full amount of the charges herein by the due date shown above, the unpaid amounts of such invoice shall accrue interest at a rate of 1.5% per month. Additionally, purchaser agrees to pay all of seller's cost of collection, including attorneys' fees. RETURNED GOODS may be subject to a restocking fee. All shipments F.O.B. manufacturer.

Accepted by: _____ Date: _____

Equipment Total:	403,971.80
Less Discount:	0.00
Tax Total:	0.00
Total (USD):	403,971.80



M3 Technology Group, Inc. (Nashville)
 925 Airpark Center Drive
 Nashville, TN, 37217
 Phone: (615) 227-0717
 Web: m3techgroup.com

Quote

Order No.: QT-152854
Quoted Date: Dec-28-2015
Delivery Date:
Quote Expires: Jan-27-2016
Your Customer #: CUST101644

BILL TO:	SHIP TO:
Lexington-Fayette Urban County Government Attn: Division of Purchasing 200 East Main Street 3rd Floor, Room 338 Lexington KY 40507	Lexington-Fayette Urban County Government Attn: Division of Purchasing 200 East Main Street 3rd Floor, Room 338 Lexington KY 40507

CUSTOMER P.O. NO.	TERMS	CONTACT
	To Be Determined	Rebecca Betts - Collin McGinley

Job/Room Reference	SHIPPING TERMS	SHIP VIA
Bid No. 189-2015-Years 2-5 PMP	Quoted (line item)	UPS Ground

NO.	ITEM	QTY.	PRICE	EXTENDED PRICE
1	M3-1YR: Year 2 Preventative Maintenance Contract	1.00	28,278.03	28,278.03
2	M3-1YR: Year 3 Preventative Maintenance Contract	1.00	28,278.03	28,278.03
3	M3-1YR: Year 4 Preventative Maintenance Contract	1.00	32,317.75	32,317.75
4	M3-1YR: Year 5 Preventative Maintenance Contract	1.00	32,317.75	32,317.75

Should purchaser fail to pay the full amount of the charges herein by the due date shown above, the unpaid amounts of such invoice shall accrue interest at a rate of 1.5% per month. Additionally, purchaser agrees to pay all of seller's cost of collection, including attorneys' fees. RETURNED GOODS may be subject to a restocking fee. All shipments F.O.B. manufacturer.
 Accepted by: _____ Date: _____

Equipment Total:	121,191.56
Less Discount:	0.00
Tax Total:	0.00
Total (USD):	121,191.56

BID BOND

AMCO Insurance Company
Nationwide Mutual Insurance Company
Allied Property & Casualty Insurance Company
1100 Locust St., Dept 2006 Des Moines, IA 50391-2006
(866) 387-0457

CONTRACTOR:
M3 Technology Group Inc
Nashville, TN

SURETY:
AMCO Insurance Company
1100 Locust St., Dept. 2006
Des Moines, IA 50391-2006

OWNER:
Lexington Fayette County Government

BOND AMOUNT: 5% Five percent of amount of bid

PROJECT:
Audio Visual Systems for Public Safety Office Complex

The Contractor and Surety are bound to the Owner in the amount set forth above, for the payment of which the Contractor and Surety bind themselves, their heirs, executors, administrators, successors and assigns, jointly and severally, as provided herein. The conditions of this Bond are such that if the Owner accepts the bid of the Contractor within the time specified in the bid documents, or within such time period as may be agreed to by the Owner and Contractor, and the Contractor either (1) enters into a contract with the Owner in accordance with the terms of such bid, and gives such bond or bonds as may be specified in the bidding or Contract Documents, with a surety admitted in the jurisdiction of the Project and otherwise acceptable to the Owner, for the faithful performance of such Contract and for the prompt payment of labor and material furnished in the prosecution thereof; or (2) pays to the Owner the difference, not to exceed the amount of this Bond, between the amount specified in said bid and such larger amount for which the Owner may in good faith contract with another party to perform the work covered by said bid, then this obligation shall be null and void, otherwise to remain in full force and effect. The Surety hereby waives any notice of an agreement between the Owner and Contractor to extend the time in which the Owner may accept the bid. Waiver of notice by the Surety shall not apply to any extension exceeding sixty (60) days in aggregate beyond the time for acceptance of bids specified in the bid documents, and the Owner and Contractor shall obtain the Surety's consent for an extension beyond sixty (60) days.

If this Bond is issued in connection with a subcontractor's bid to a Contractor, the term Contractor in this Bond shall be deemed to be a Subcontractor and the term Owner shall be deemed to be Contractor.

When this Bond has been furnished to comply with a statutory or other legal requirement in the location of the Project, any provision in this Bond conflicting with said statutory or legal requirement shall be deemed deleted herefrom and provisions conforming to such statutory or other legal requirement shall be deemed incorporated herein. When so furnished, the intent is that this bond shall be construed as a statutory bond and not as a common law bond.

Signed and sealed this 28th day of December 2015

Lehuca Betts
(Witness)

M3 Technology Group Inc
Kelly L. Bu (Seal)
(Principal)

(Title)

Kimberly Bull
(Witness)

AMCO Insurance Company
Gary Pigg (Seal)
(Surety)

(Title) Gary Pigg, Attorney-in-Fact



Power of Attorney

KNOW ALL MEN BY THESE PRESENTS THAT:

Nationwide Mutual Insurance Company, an Ohio corporation
Farmland Mutual Insurance Company, an Iowa corporation
Nationwide Agribusiness Insurance Company, an Iowa corporation

AMCO Insurance Company, an Iowa corporation
Allied Property and Casualty Insurance Company, an Iowa corporation
Depositors Insurance Company, an Iowa corporation

hereinafter referred to severally as the "Company" and collectively as the "Companies," each does hereby make, constitute and appoint:

Gary Pigg

each in their individual capacity, its true and lawful attorney-in-fact, with full power and authority to sign, seal, and execute on its behalf any and all bonds and undertakings, and other obligatory instruments of similar nature, in penalties not exceeding the sum of

Five Hundred Thousand and no/100

\$500,000.00

and to bind the Company thereby, as fully and to the same extent as if such instruments were signed by the duly authorized officers of the Company; and all acts of said Attorney pursuant to the authority given are hereby ratified and confirmed.

This power of attorney is made and executed pursuant to and by authority of the following resolution duly adopted by the board of directors of the Company:

"RESOLVED, that the president, or any vice president be, and each hereby is, authorized and empowered to appoint attorneys-in-fact of the Company, and to authorize them to execute and deliver on behalf of the Company any and all bonds, forms, applications, memorandums, undertakings, recognizances, transfers, contracts of indemnity, policies, contracts guaranteeing the fidelity of persons holding positions of public or private trust, and other writings obligatory in nature that the business of the Company may require; and to modify or revoke, with or without cause, any such appointment or authority; provided, however, that the authority granted hereby shall in no way limit the authority of other duly authorized agents to sign and countersign any of said documents on behalf of the Company."

"RESOLVED FURTHER, that such attorneys-in-fact shall have full power and authority to execute and deliver any and all such documents and to bind the Company subject to the terms and limitations of the power of attorney issued to them, and to affix the seal of the Company thereto; provided, however, that said seal shall not be necessary for the validity of any such documents."

This power of attorney is signed and sealed under and by the following bylaws duly adopted by the board of directors of the Company.

Execution of Instruments. Any vice president, any assistant secretary or any assistant treasurer shall have the power and authority to sign or attest all approved documents, instruments, contracts, or other papers in connection with the operation of the business of the company in addition to the chairman of the board, the chief executive officer, president, treasurer or secretary; provided, however, the signature of any of them may be printed, engraved, or stamped on any approved document, contract, instrument, or other papers of the Company.

IN WITNESS WHEREOF, the Company has caused this instrument to be sealed and duly attested by the signature of its officer the 13th day of February, 2014.

Terrance Williams, President and Chief Operating Officer of Nationwide Agribusiness Insurance Company and Farmland Mutual Insurance Company; and **Vice President** of Nationwide Mutual Insurance Company, AMCO Insurance Company, Allied Property and Casualty Insurance Company, and Depositors Insurance Company

ACKNOWLEDGMENT

STATE OF IOWA, COUNTY OF POLK: ss

On this 13th day of February, 2014, before me came the above-named officer for the Companies aforesaid, to me personally known to be the officer described in and who executed the preceding instrument, and he acknowledged the execution of the same, and being by me duly sworn, deposes and says, that he is the officer of the Companies aforesaid, that the seals affixed hereto are the corporate seals of said Companies, and the said corporate seals and his signature were duly affixed and subscribed to said instrument by the authority and direction of said Companies.

Sandy Alitz
Notarial Seal - Iowa
Commission Number 152785
My Commission Expires March, 24, 2017

Notary Public
My Commission Expires
March 24, 2017

CERTIFICATE

I, Robert W Horner III, Secretary of the Companies, do hereby certify that the foregoing is a full, true and correct copy of the original power of attorney issued by the Company; that the resolution included therein is a true and correct transcript from the minutes of the meetings of the boards of directors and the same has not been revoked or amended in any manner; that said Terrance Williams was on the date of the execution of the foregoing power of attorney the duly elected officer of the Companies, and the corporate seals and his signature as officer were duly affixed and subscribed to the said instrument by the authority of said board of directors; and the foregoing power of attorney is still in full force and effect.

IN WITNESS WHEREOF, I have hereunto subscribed my name as Secretary, and affixed the corporate seals of said Companies this 28th day of December, 20 15.

Secretary

This Power of Attorney Expires March 24, 2017

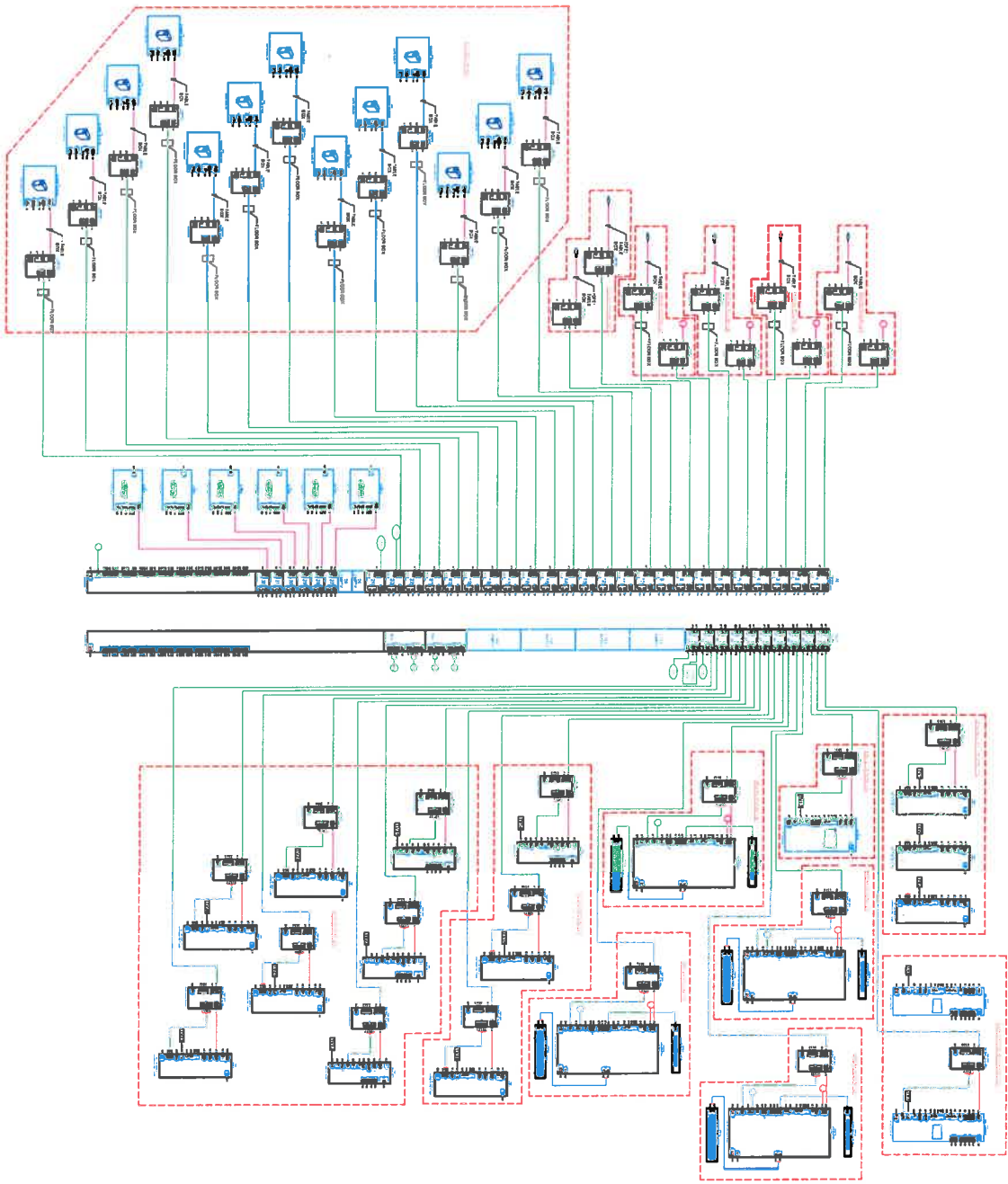

LEXINGTON EOC AUDIO/VIDEO SYSTEM

 101 Alameda Street, Suite 100
 Cambridge, Massachusetts
 Phone: 617.552.4712
 Fax: 617.552.4713
 www.lexington.com

<p> AV SYSTEM NAME: AV SYSTEM SYSTEM: AV SYSTEM DATE: 10/12/00 DRAWN BY: JMM CHECKED BY: JMM APPROVED BY: JMM REVISIONS: </p>	<p> AV SYSTEM NAME: AV SYSTEM SYSTEM: AV SYSTEM DATE: 10/12/00 DRAWN BY: JMM CHECKED BY: JMM APPROVED BY: JMM REVISIONS: </p>
---	---

12-23-16
 AV 101
 Q1303000X



AMS
 813 Airport Center Drive
 Lexington, MA 01824
 Phone: 617-557-0712
 Fax: 617-557-0713
 www.ams.com

6700 South Shore
 Lexington, MA 01824
 Phone: 617-557-0712
 Fax: 617-557-0713
 www.ams.com

LEXINGTON EOC STAND ALONES AUDIO/VIDEO SYSTEM

NO.	DESCRIPTION	QTY	UNIT PRICE	TOTAL PRICE
1	AV SYSTEM	1		
2	STAND	1		
3	AUDIO/VIDEO LINE SCHEMATIC	1		
4	12-23-15			
5	AV 102			
6	DT-XXXXXX			

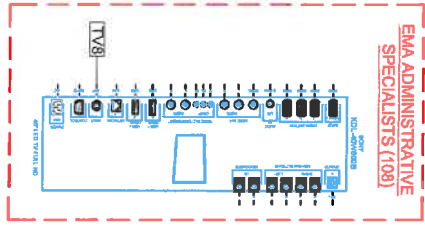
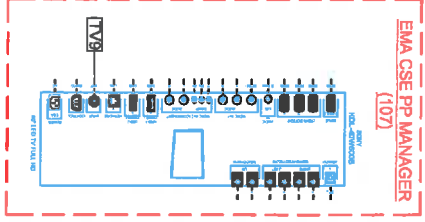
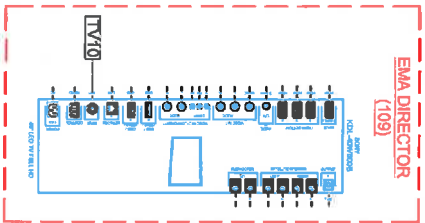
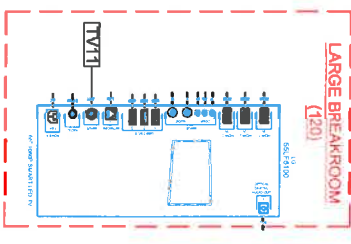
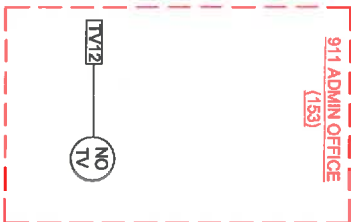
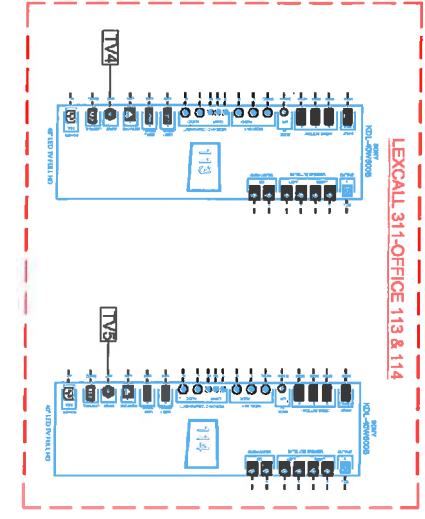
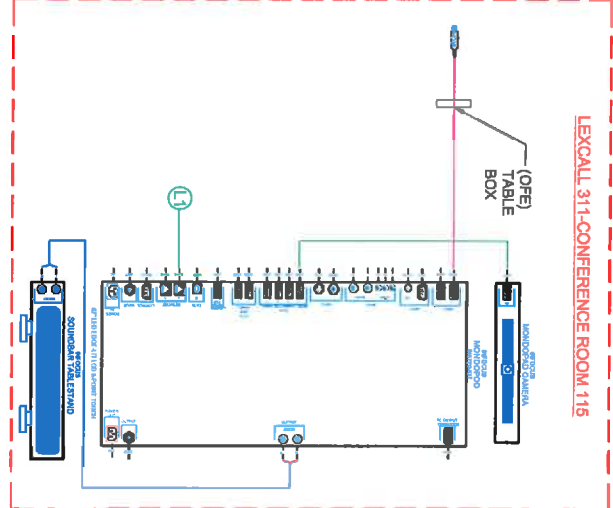

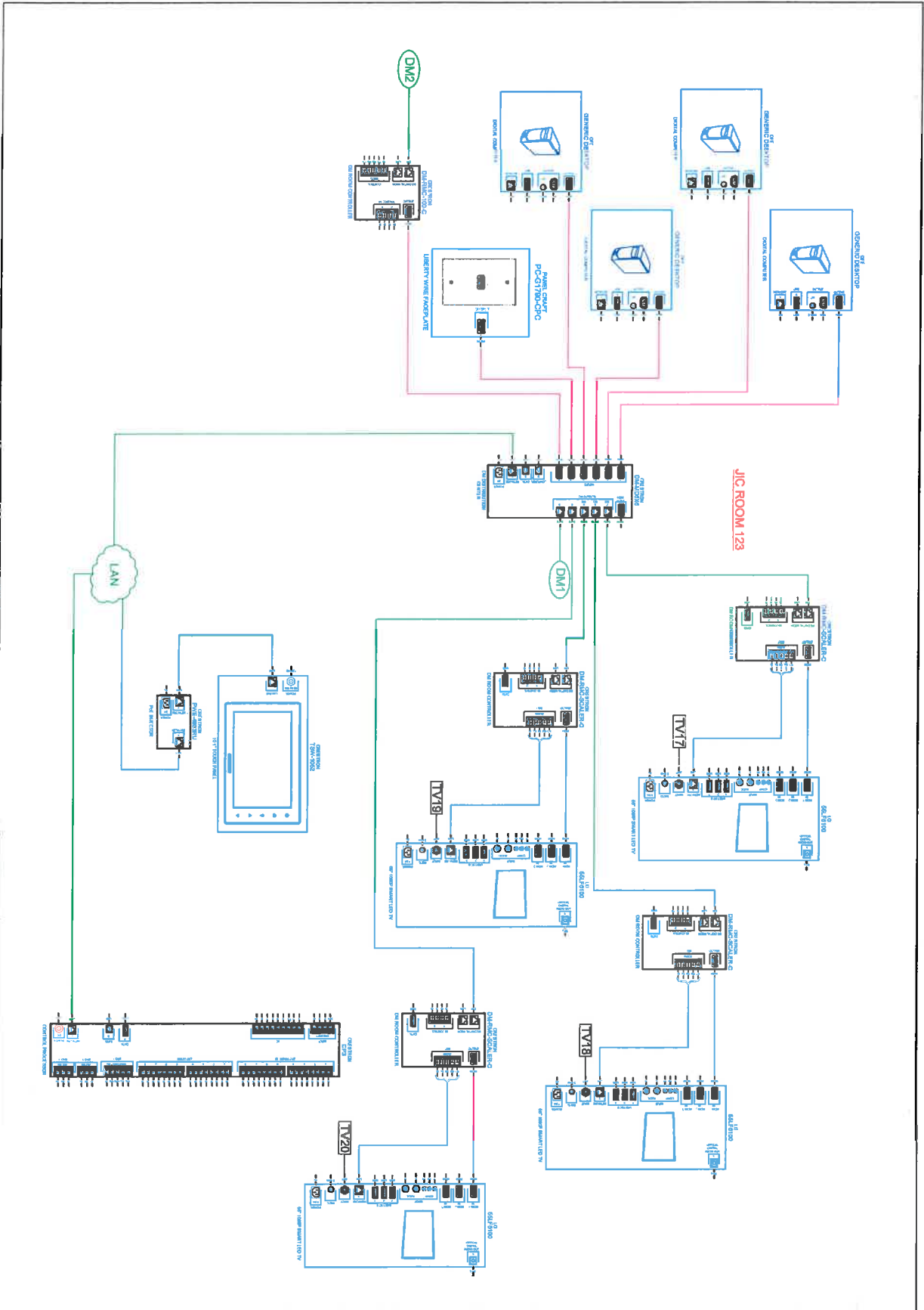

AVS
 818 Atlantic Avenue
 Suite 202
 Boston, MA 02111
 Phone: 617-552-2222
 Fax: 617-552-2223
 www.avs.com

LEXINGTON EOC JIC ROOM 123 AUDIO/VIDEO SYSTEM

PROJECT	AV SYSTEM
CLIENT	AVS
DATE	12-23-15
DESIGNER	AVS
INSTALLER	AVS
LOCATION	JIC ROOM 123
ROOM	JIC ROOM 123
DATE	12-23-15
BY	AVS
CHECKED BY	AVS
DATE	12-23-15
PROJECT NO.	12-23-15
REVISIONS	
NO.	DESCRIPTION
1	INITIAL SCHEMATIC
2	AVS
3	AVS
4	AVS
5	AVS
6	AVS
7	AVS
8	AVS
9	AVS
10	AVS
11	AVS
12	AVS
13	AVS
14	AVS
15	AVS
16	AVS
17	AVS
18	AVS
19	AVS
20	AVS
21	AVS
22	AVS
23	AVS
24	AVS
25	AVS
26	AVS
27	AVS
28	AVS
29	AVS
30	AVS
31	AVS
32	AVS
33	AVS
34	AVS
35	AVS
36	AVS
37	AVS
38	AVS
39	AVS
40	AVS
41	AVS
42	AVS
43	AVS
44	AVS
45	AVS
46	AVS
47	AVS
48	AVS
49	AVS
50	AVS

12-23-15
 AV 103
 01-XXXXXX

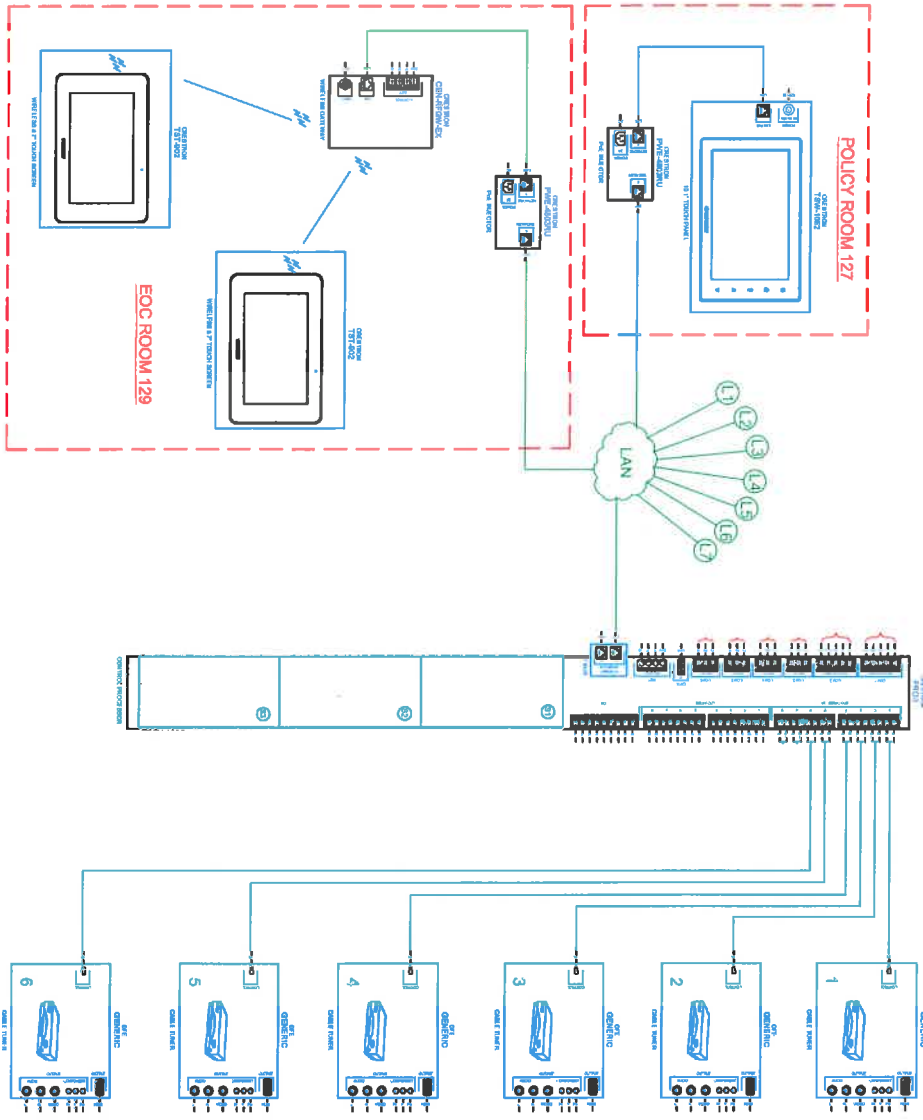

LEXINGTON EOC MASTER CONTROL SYSTEM



 8512 Airport Center Drive
 Lexington, KY 40503
 Phone: 618-527-8717
 Fax: 618-527-8718
 Email: info@lexingtonaudio.com

Project: Lexington EOC
 Location: Lexington, KY 40503
 Date: 12/23/15
 Rev: 01

Item #	Description	Quantity	Unit Price	Total Price
1	Control Console	1		
2	Monitor	1		
3	Control Console	1		
4	Monitor	1		
5	Control Console	1		
6	Monitor	1		
7	Control Console	1		
8	Monitor	1		
9	Control Console	1		
10	Monitor	1		

Project: AV SYSTEM
 Location: Lexington, KY
 Date: 12-23-15
 Rev: MC 101
 Drawing No: QT-XXXXXXX

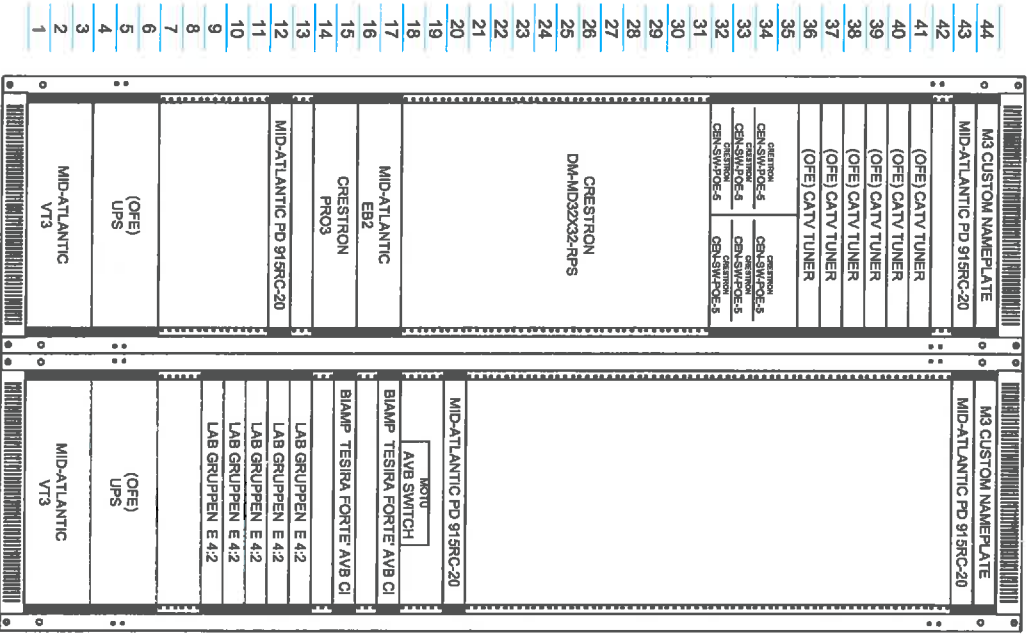
44 SPACE 44 SPACE



MRK-4431-AV
MID-ATLANTIC

MRK-4431-AV-AB
MID-ATLANTIC

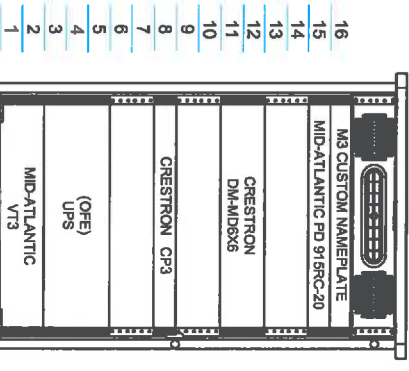

MFR-1627GC
MID-ATLANTIC

LEXINGTON EOC RACK LAYOUTS

4431 Airport, Columbia Drive
Raleigh, NC 27617
Phone: 919.487.7777
Fax: 919.487.4444
www.lexington-oc.com

Model	Part	Qty	Notes
MFR-1627GC	12-23-15	1	
MRK-4431-AV	RK 101	1	
MRK-4431-AV-AB	RK 101	1	
RACK LAYOUT			

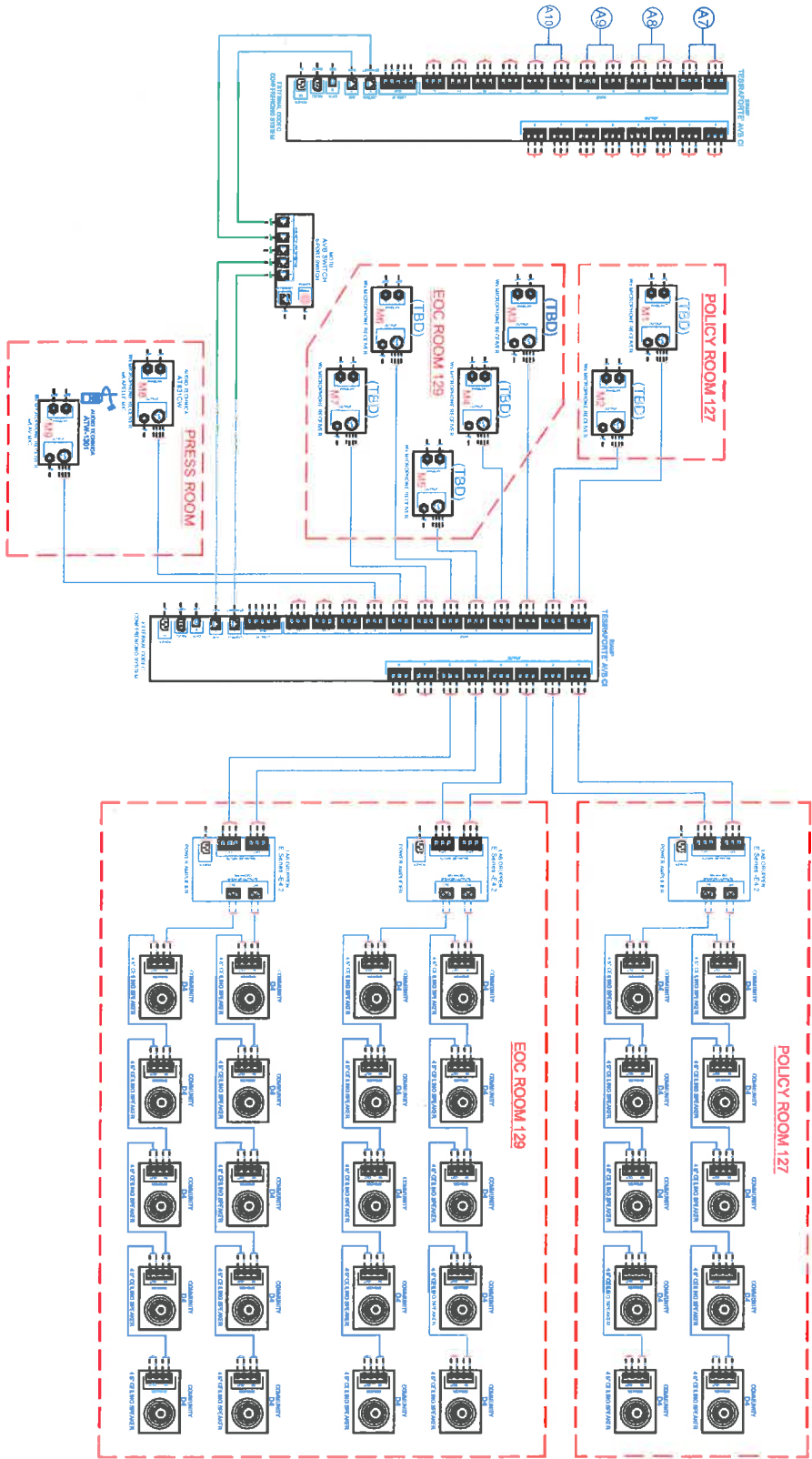

LEXINGTON EOC
AUDIO SYSTEM



 603 Airport Center Drive
 Lexington, MA 01824
 Phone: 978.689.1199
 Fax: 978.689.1198
 www.wbe.com

MODEL: AV-07010A
 PART: 1000000000
 DATE: 12/23/15
 REV: 1
 DRAWN BY: J. B. BROWN
 CHECKED BY: J. B. BROWN
 APPROVED BY: J. B. BROWN
 TITLE: EOC
 AUDIO/VIDEO
 LINE
 SCHEMATIC

12-23-15
 A 101
 01-30000000

LFUCG PSOC Master

DMC-D: Todd Lewis / D-4K-000-110923-2522
DMC-E: Todd Lewis / E-4K-000-120321-1678
Created: 12/22/2015

Contact Name: Todd Lewis
Email: toddlewis@m3video.com
Company: M3 Technology Group

If you would like to use this as your purchase order, please email the PDF version to orders@crestron.com (or fax to 201-767-1905). Be sure to include all standard order information as well: Bill-To Address, Ship-To Address, Shipping Method

Actual product availability is subject to verification. Please refer to the current Crestron price list, and consult your Crestron representative, to confirm availability and pricing for each product.

DM Switcher Configuration



Project Name: LFUCG PSOC Master
Contact Name: Todd Lewis

Company: M3 Technology Group

Created: 12/22/2015
Email: toddlewis@m3video.com

Qty	Model (Switcher)	Dealer Net	List
1	DM-MD32X32-RPS - 32x32 DigitalMedia™ Switcher w/Redundant Power Supply	\$9,200	\$18,400
Slot	Model (Input Cards)	Dealer Net	List
1	DMC-C - HDBaseT® Certified DigitalMedia 8G+® Input Card for DM® Switchers	\$300	\$600
2	DMC-C - HDBaseT® Certified DigitalMedia 8G+® Input Card for DM® Switchers	\$300	\$600
3	DMC-C - HDBaseT® Certified DigitalMedia 8G+® Input Card for DM® Switchers	\$300	\$600
4	DMC-C - HDBaseT® Certified DigitalMedia 8G+® Input Card for DM® Switchers	\$300	\$600
5	DMC-C - HDBaseT® Certified DigitalMedia 8G+® Input Card for DM® Switchers	\$300	\$600
6	DMC-C - HDBaseT® Certified DigitalMedia 8G+® Input Card for DM® Switchers	\$300	\$600
7	DMC-C - HDBaseT® Certified DigitalMedia 8G+® Input Card for DM® Switchers	\$300	\$600
8	DMC-C - HDBaseT® Certified DigitalMedia 8G+® Input Card for DM® Switchers	\$300	\$600
9	DMC-C - HDBaseT® Certified DigitalMedia 8G+® Input Card for DM® Switchers	\$300	\$600
10	DMC-C - HDBaseT® Certified DigitalMedia 8G+® Input Card for DM® Switchers	\$300	\$600
11	DMC-C - HDBaseT® Certified DigitalMedia 8G+® Input Card for DM® Switchers	\$300	\$600
12	DMC-C - HDBaseT® Certified DigitalMedia 8G+® Input Card for DM® Switchers	\$300	\$600
13	DMC-C - HDBaseT® Certified DigitalMedia 8G+® Input Card for DM® Switchers	\$300	\$600
14	DMC-C - HDBaseT® Certified DigitalMedia 8G+® Input Card for DM® Switchers	\$300	\$600
15	DMC-C - HDBaseT® Certified DigitalMedia 8G+® Input Card for DM® Switchers	\$300	\$600
16	DMC-C - HDBaseT® Certified DigitalMedia 8G+® Input Card for DM® Switchers	\$300	\$600
17	DMC-C - HDBaseT® Certified DigitalMedia 8G+® Input Card for DM® Switchers	\$300	\$600
18	DMC-C - HDBaseT® Certified DigitalMedia 8G+® Input Card for DM® Switchers	\$300	\$600
19	DMC-C - HDBaseT® Certified DigitalMedia 8G+® Input Card for DM® Switchers	\$300	\$600
20	DMC-C - HDBaseT® Certified DigitalMedia 8G+® Input Card for DM® Switchers	\$300	\$600
21	DMC-C - HDBaseT® Certified DigitalMedia 8G+® Input Card for DM® Switchers	\$300	\$600
22	DMC-C - HDBaseT® Certified DigitalMedia 8G+® Input Card for DM® Switchers	\$300	\$600
23	DMC-C - HDBaseT® Certified DigitalMedia 8G+® Input Card for DM® Switchers	\$300	\$600
24	DMC-C - HDBaseT® Certified DigitalMedia 8G+® Input Card for DM® Switchers	\$300	\$600
25	Empty	N/A	N/A
26	Empty	N/A	N/A
27	DMC-4K-HD * - 4K HDMI® Input Card for DM® Switchers	\$400	\$800
28	DMC-4K-HD * - 4K HDMI® Input Card for DM® Switchers	\$400	\$800
29	DMC-4K-HD * - 4K HDMI® Input Card for DM® Switchers	\$400	\$800
30	DMC-4K-HD * - 4K HDMI® Input Card for DM® Switchers	\$400	\$800
31	DMC-4K-HD * - 4K HDMI® Input Card for DM® Switchers	\$400	\$800
32	DMC-4K-HD * - 4K HDMI® Input Card for DM® Switchers	\$400	\$800

* DisplayPort to HDMI cables not included.

Actual product availability is subject to verification. Please refer to the current Crestron price list, and consult your Crestron representative, to confirm availability and pricing for each product.

Project Name: LFUCG PSOC Master
Contact Name: Todd Lewis

Company: M3 Technology Group

Created: 12/22/2015
Email: toddlewis@m3video.com

Slot	Model (Output Cards)	Dealer Net	List
1	DMC-4K-CO-HD - 2-Channel HDBaseT® Certified 4K DigitalMedia 8G+® Output Card for DM® Switchers	\$650	\$1,300
2	DMC-4K-CO-HD - 2-Channel HDBaseT® Certified 4K DigitalMedia 8G+® Output Card for DM® Switchers	\$650	\$1,300
3	DMC-4K-CO-HD - 2-Channel HDBaseT® Certified 4K DigitalMedia 8G+® Output Card for DM® Switchers	\$650	\$1,300
4	DMC-4K-CO-HD - 2-Channel HDBaseT® Certified 4K DigitalMedia 8G+® Output Card for DM® Switchers	\$650	\$1,300
5	DMC-4K-CO-HD - 2-Channel HDBaseT® Certified 4K DigitalMedia 8G+® Output Card for DM® Switchers	\$650	\$1,300
6	DMC-4K-CO-HD - 2-Channel HDBaseT® Certified 4K DigitalMedia 8G+® Output Card for DM® Switchers	\$650	\$1,300
7	DMC-4K-CO-HD - 2-Channel HDBaseT® Certified 4K DigitalMedia 8G+® Output Card for DM® Switchers	\$650	\$1,300
8	DMC-4K-CO-HD - 2-Channel HDBaseT® Certified 4K DigitalMedia 8G+® Output Card for DM® Switchers	\$650	\$1,300
9	DMC-4K-CO-HD - 2-Channel HDBaseT® Certified 4K DigitalMedia 8G+® Output Card for DM® Switchers	\$650	\$1,300
10	DMC-4K-CO-HD - 2-Channel HDBaseT® Certified 4K DigitalMedia 8G+® Output Card for DM® Switchers	\$650	\$1,300
11	DMC-BLANK	N/A	N/A
12	DMC-BLANK	N/A	N/A
13	DMC-BLANK	N/A	N/A
14	DMC-BLANK	N/A	N/A
15	DMC-HDO - 2-Channel HDMI® Output Card for DM® Switchers	\$350	\$700
16	DMC-HDO - 2-Channel HDMI® Output Card for DM® Switchers	\$350	\$700

If you would like to use this as your purchase order, please email the PDF version to orders@crestron.com (or fax to 201-767-1905). Be sure to include all standard order information as well: Bill-To Address, Ship-To Address, Shipping Method

Actual product availability is subject to verification. Please refer to the current Crestron price list, and consult your Crestron representative, to confirm availability and pricing for each product.

DM Switcher Configuration



Project Name: LFUCG PSOC Master
Contact Name: Todd Lewis

Company: M3 Technology Group

Created: 12/22/2015
Email: toddlewis@m3video.com

Qty	Model (Transmitters)	Dealer Net	List
24	DM-TX-201-C - DigitalMedia 8G+® Transmitter 201	\$15,600	\$31,200
Qty	Model (Receivers)	Dealer Net	List
19	DM-RMC-SCALER-C - DigitalMedia 8G+® Receiver & Room Controller w/Scaler	\$13,300	\$26,600
Total:		\$54,900	\$109,800

Actual product availability is subject to verification. Please refer to the current Crestron price list, and consult your Crestron representative, to confirm availability and pricing for each product.

Project Name: LFUCG PSOC Master
Contact Name: Todd Lewis

Company: M3 Technology Group

Created: 12/22/2015
Email: toddlewis@m3video.com

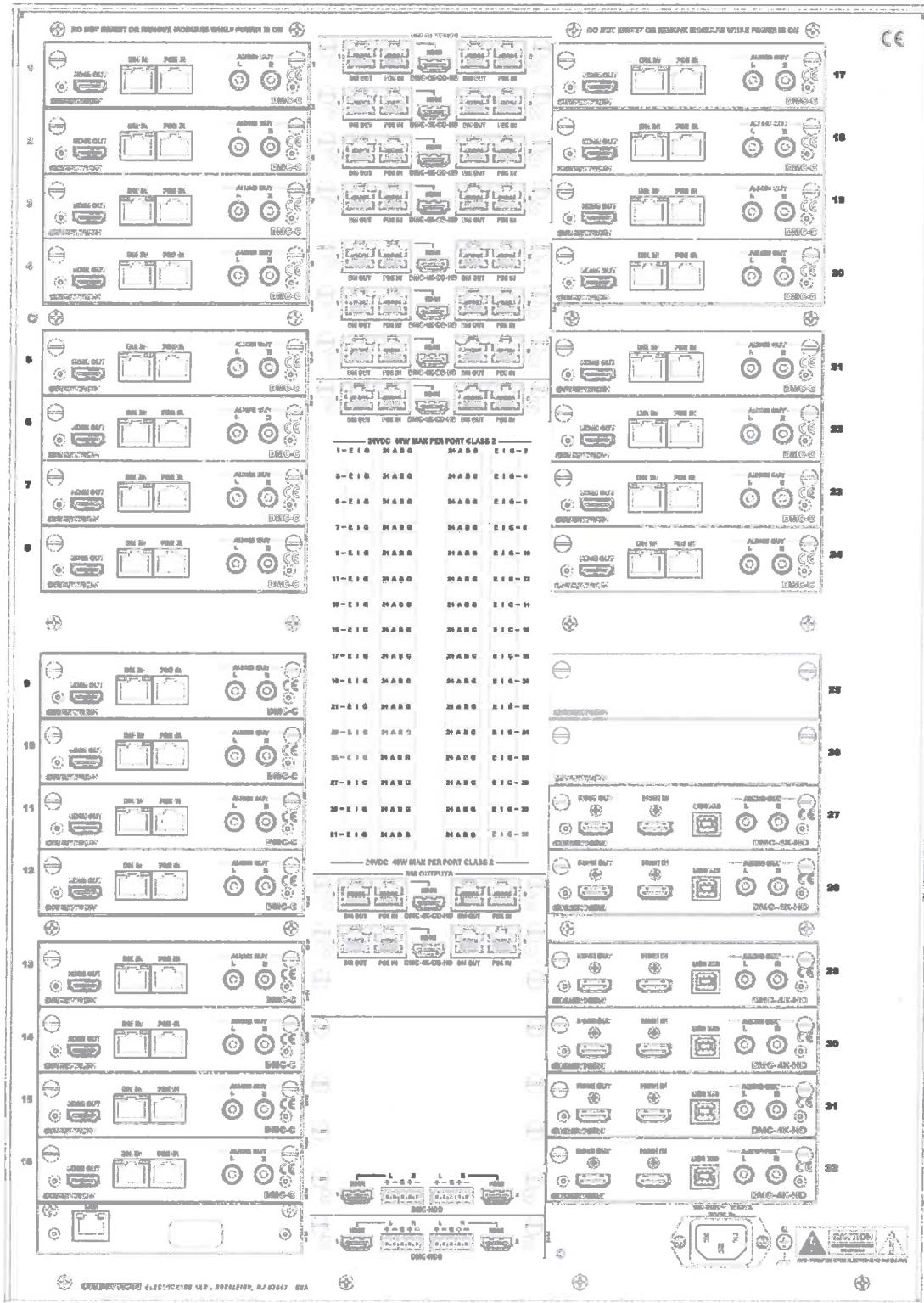

High-level Project Plan for Lexington-Fayette EOC

- 1) Design engineering has been completed for estimate purposes. Upon award of Project, M3 Technology Group, Inc. will review system design with customer before ordering required equipment.
- 2) Upon approval of system design, M3 will order all required equipment and material to complete the Project installation upon receipt of a Purchase Order from customer.
- 3) All equipment will be received at M3 office and transported to Project site as required for installation. M3 will install all cabling and equipment in a secure building.
- 4) Upon completion of cable termination, M3 will test all cable and connectors. After cable pass/acceptance of quality connections, M3 will connect all equipment and test.
- 5) After successful testing of cable, connectors and equipment, software Programming will be installed and fully tested for all functionality as required and requested.
- 6) M3 will provide full system training / testing with Customer at completion of installation.

Lexington LFUCCG PSOC

Period Highlight: 1



ACTIVITY	PLAN	PLAN	ACTUAL	ACTUAL	PERCENT COMPLETE	PERIODS
	START	DURATION	START	DURATION		
Cabling & Infrastructure Installation	3/7/2016	3/25/2016	3/7/2016	3/25/2016	100%	1 2 3 4 5 6 7 8 9 10 11 12 13 14 15 16 17 18 19 20 22
Equipment Installation	3/21/2016	4/8/2015	3/21/2016	4/8/2015	100%	1 2 3 4 5 6 7 8 9 10 11 12 13 14 15 16 17 18 19 20 22
System Programming	4/11/2016	4/22/2016	4/11/2016	4/22/2016	100%	1 2 3 4 5 6 7 8 9 10 11 12 13 14 15 16 17 18 19 20 22
Commissioning	4/25/2016	4/28/2016	4/25/2016	4/28/2016	100%	1 2 3 4 5 6 7 8 9 10 11 12 13 14 15 16 17 18 19 20 22

Preventive Maintenance Plan (PMP) Overview

M3 Technology Group provides standard warranty coverage for workmanship on all AV systems it installs in conjunction with manufacturers' equipment warranties. In many cases, customers elect to employ M3's Preventive Maintenance Program (PMP), our popular 1-year priority service, maintenance and training plan that keeps their systems running in top form. A PMP plan provides an additional layer of security and protection with new systems, as well as new users, and helps to promote smooth operation of all components.

Standard one-year PMP coverage includes:

- (2) Two system inspections per year** – this includes a complete system inspection for functionality, cleanliness, and equipment operability. During these visits, M3 will perform the following tasks:
 - Perform a complete system inspection for functionality.
 - Clean and inspect (as required by manufacturer) all equipment, racks, equipment fans, cables and connectors, assuring they are clean and free from defects.
 - Replace any non-rechargeable batteries that have failed with new ones. (Consumables such as lamps, filter are excluded from PMP coverage and are subject to charge)
 - Make minor tweaks to the system to enhance performance due to equipment aging, (i.e. projector optical and mechanical adjustments for optimizing image quality, peak and gain attenuation adjustments for optimizing cable lengths, and minor amplification adjustments as needed for optimizing sound quality).
 - Perform system walk-thrus with customer representative to demonstrate service performed, system functionality and cleanliness, and inform customer of any defective equipment that requires repair or replacement.
- (1) One additional training session** that explains operation of the system to any new clients or employees of the customer.
- Loaner equipment:** Provide loaner equipment, if available, if system is down for emergency repair.
- Reporting:** Provide a detailed service report to you within one week of a system inspection.
- Unlimited troubleshooting support:** PMP customers can access unlimited telephone support from the M3 Help Desk during normal business hours, 8am-5pm CST Monday – Friday.
 - a. PMP customers have priority over standard warranty and non-warranty customers for Help Desk support.
 - b. Should more than phone support be required, M3 can dispatch a service technician to you site to assess the failure and determine the best course of action for repair. Response time will be dictated by the selected M3 service contract in force and severity of the problem. On-site emergency call are subject to addition.



PMP plans are available in 1-year, 3-year, and 5-year increments. Please discuss service contract options with your M3 Representative if you would like to expand your service coverage.

Contact M3 Managed Services Support Group

8am-5pm (CST) Monday - Friday
877-227-0717 • Service@M3TechGroup.com



Terms of Contract

- All preventive maintenance service items are included at no extra charge with your PMP contract.
- M3 service contract clients often elect to keep an open PO for emergency services. In this manner, the service process is expedited with M3, allowing for us to process any equipment warranty or service work promptly.
- Service clients pay for labor, shipping and replacement equipment on a per-incident basis, and only as incurred.

About M3 Technology Group

Company Overview

M3 Technology Group, Inc. is a leading AV system integrator and ITS provider of [audio-visual, video conferencing, managed services](#), and [structured cabling solutions](#). M3 is known for delivering outstanding customer service and best-in-class technologies that enhance learning, collaboration, and productivity.

Since 2002, M3 has designed and installed hundreds of audio-visual, videoconferencing and IT infrastructure deployments of varying complexity, with project values ranging from \$10,000 to \$3M. M3 serves clients in education, corporate, healthcare, house of worship, entertainment, military, government, and hospitality markets throughout the Southeast and Continental US.

M3 maintains General Contractor licenses in the states of Tennessee, Alabama, and Kentucky.

M3 is InfoComm International APEX accredited, and certified by dozens of manufacturers.

M3 is a privately held corporation and registered **Tennessee Drug Free Workplace**, headquartered in Nashville TN, with additional offices in Knoxville TN, Memphis TN, and Huntsville AL.

Ownership

M3 Technology Group was incorporated in 2002 as Multi Media Masters by now Chairman/President, Bruce Cordell. In 2009 the company name was changed to M3 Technology Group. Ownership of this Tennessee Corporation is held by the following individuals:

- Bruce Cordell, Chairman
- Jason Taylor, Chief Executive Officer
- Chris Montini, Chief Technology Officer
- Kelly Burns, Chief Operating Officer
- Phillip Cordell, Director of Engineering
- Rusty Howell, Senior Account Manager

Staff and Office Locations

M3 staff of 55 includes full-time sales and administrative personnel; industry accredited design engineers, project managers and programmers; and AV and IT installation and service technicians that support all regional M3 offices and the entire M3 client base. M3 has an additional sub-contractor pool of technicians who provide additional support with installation and service when needed.

M3 Technology Group delivers sales, engineering and technical support on all products and services to customers throughout the continental US with a concentration on the below Southeastern states:



Summary of Capabilities

Focus	Services	Markets	Applications	M3 Facilities
<ul style="list-style-type: none"> • Audio-visual/video • Videoconferencing • Managed services • Structured cabling • IT infrastructure 	<ul style="list-style-type: none"> • Consultation • Design • Construction • Programming • Installation • Service • Training 	<ul style="list-style-type: none"> • Education • Corporate • Medical/Healthcare • Entertainment • Military • State/Local Gov. • Hospitality • House of worship 	<ul style="list-style-type: none"> • Boardrooms/Conference rooms • Auditoriums • Training facilities • Network Operations Centers (NOC) • Courtrooms • Operating rooms • Sanctuaries • Restaurants 	<ul style="list-style-type: none"> • Nashville TN • Knoxville TN • Memphis TN • Huntsville AL offices • Videoconferencing facilities • Pre-fab staging labs • Warehousing • Service vehicle fleet • Sales, engineering, service, ITS depts.

Mission Statement

M3 is committed to providing the best beginning to end solutions and user experience on an individual basis, and takes pride in a strong reputation for integrity, and for regularly exceeding client expectations.

M3 maintains close collaboration between its sales, engineering and integration teams to ensure synergy throughout every project, and to maintain superior attention to detail. M3 follows standard practices and procedures for the fixed installation of Audio Visual Systems as developed by [InfoComm International](#), and for ITS systems and infrastructure in accordance with [BICSI](#).

Drug Free Workplace

M3 Technology Group, Inc. is a member of **Tennessee Drug Free Workplace**. Due to the nature of our work within schools and churches containing childcare facilities we require extensive back ground checks and drug testing on all employees and subcontractors. None of M3's employees or subcontractors have ever been convicted of, or pled guilty to a felony.

Employee Competence

M3 Technology Group employees are highly qualified, AV and IT industry accredited professionals with extensive training, certifications, and specialized skills. M3 takes great care in assembling project teams specifically aligned to the project at hand; its specifications, unique environment, and parameters. M3 employees are chosen for their skill and industry experience as well as for their ability to work in a team environment.

M3 supports employee education and facilitates regular certification and learning opportunities for its staff. M3 actively remains in the forefront of emerging AV and IT technologies so that our team can clearly determine and present the benefits to our customers.

M3 conducts regular team building social activities that foster unity and moral, and issues performance awards and employee recognition. M3 was voted a 2014 top workplace by *Nashville Business Journal* and, and top workplace in both 2014 and 2015 by *The Tennessean*.



Employee Certifications

Over 60% of M3 technical staff is InfoComm CTS, CTS-D or CTS-I certified, Bicsi certified and/or industry trained in programming, testing, installation and service of various AV and structured cabling technology components. All sales and technical staff members are trained. Additional manufacturer certifications are held by various M3 personnel.

M3 Technology group is a recognized InfoComm International **APEX Certified** company, and Bicsi Corporate member.



AV/IT Technology Reseller Status

M3 is an authorized reseller of over 200 video, audio, and IT product lines, a partial listing of which is available online at <http://m3techgroup.com/manufacture-directory/> and may be appended to this document.

Authorized Service Center

M3 Technology Group coordinates with all of its manufacturer's service centers on behalf of clients.

Office Locations

Headquarters

Nashville
925 Airpark Center Drive
Nashville, TN 37211
(615) 227-0717 office

Contact:
Jason Taylor, CEO

Branch Sales/Service Office

Knoxville
8705 Unicorn Drive, Suite A114
Knoxville, TN 37923
(865) 691-1124 office

Contact:
David West, Branch Manager

Branch Sales Offices

Huntsville AL
Contact: Allen Brooks, CTS, Senior Account Manager
(256) 658-1151

Memphis TN
Contact: Michael Towne, Senior Account Manager
(901) 674-2494

M3 Applicable State Licensing

M3 Technology Group, Inc. is licensed to conduct business in the states of Tennessee, Alabama and Kentucky. Current licensing information includes:

State of Tennessee Contractors License #00049943

- S- Installation of Audio & Video Equipment/Low-Voltage; CE-D
- Unlimited
- Expires 1/31/2015 - active since 1/2/2002

Alabama General Contractors License #42530 (ref F. 27 51 23-11):

- Unlimited
- Classification: E-S: Low Voltage

Kentucky General Contractors License #07447880

M3 Number/Type of Employees

Total Employees	55
Designers/Engineers	6
Installation Technicians	19
Project Managers	4
Software Programmers	2
Sales & Administration	25

M3 Industry Certifications & Associations

Project Experience

Since 2002, M3 has installed hundreds of AV, videoconferencing and IT systems throughout the Southeast. Project scopes have ranged from single presentation spaces to multi-room campus-wide deployments of complex technologies, with project values from \$10K to over \$3M. M3's technical staff comprises seasoned professionals with extensive training and experience in Construction, Telecommunications, AV and IT.

Industry Associations

M3's AV and ITS staff are among the most highly accredited, experienced, and certified professionals in the AV and IT industries. Qualifications include:

- Prestigious 2015 InfoComm APEX accreditation –
- **Over 60% of technical staff are CTS, CTS-D or CTS-I-certified**
- Fully certified/accredited by dozens of top manufacturers for programming, installation



Certification Summary

- Aerohive partner
- AMX Certified (ACE Expert) Programming, NAM-Programming 1
- AllWorx VoIP certified business partner
- Belden copper/fiber, designer certified
- BiAmp Audio DSP Design/Installation Certification, Tesira Certification
- BICSI, RCDD Certified, Technician & Installer Level Certified
- Cambridge Sound Management, Certified Masking Expert
- Certified Wireless Technology Specialist (CWTS)
- Chief Certified Partner
- Cisco Select Partner, Express Video Specialization; Cisco Meraki Partner
- Clearone Professional Audio Conferencing Specialist
- Commscope business partner
- Corning Fiber Certified Installer
- Corning Network Preferred Installer (NPI)
- Crestron Advanced Programming, DMC-D, DMC-E, DMC-T Certification, DMC-T-4K, DMC-D-4K, CTI-P201 Core System Programming
- Extron A/V Technology Design, Configurable Control Systems Certification
- General business partner, copper/fiber certified
- Hubbell business partner, Premise Wiring's Mission Critical® certified
- OCC business partner, copper/fiber certified
- Panduit business partner & certified installer, copper/fiber certified
- Polycom Certified Video Conferencing Technologies, ATX Certified, IVOT200, IVOS100, Federal Certification FSIST300, RealPresence Platform Technical Certifications: (technical) RPPOT200, (Collaboration server) RPPCSOS103, (CloudAXIS Suite) RPCAEOS102, (Assessment/platform Level 1) RPPEXOT104, (Video Endpoints) RPEOT200
- Tyco Electronics, Amp, ADC business partner
- Yamaha Commercial Audio



M3 Service & Support Capabilities

M3 Technology Group maintains fully equipped warehousing, staging, service and installation facilities at its Nashville and Knoxville offices, each with complete technical staffing, tools and supplies necessary to perform all functions associated with integrated AV system and structure cabling installation activities.



M3 warehousing facilities are used for equipment procurement and job storage



M3 staging facilities are used for system pre-fabrication and testing



M3 maintains a fleet of 16 fully equipped installation and service vehicles deployed in Nashville, Knoxville and Memphis.

A note about documentation

All system design, built documentation is provided in standard CAD formats in accordance with industry standards of practice. Sample drawings can be furnished upon request.



Comprehensive system testing is performed during both pre-staging and final system commissioning.

M3 Workmanship

M3 Technology Group technicians are expertly trained in all aspects of system assembly, including rack wiring, equipment programming and on-site cabling and equipment installation. Their workmanship speaks for itself.



M3 delivers precision rack wiring and clear equipment labelling to ensure that system users can easily navigate equipment racks.



Complex mechanical assemblies like this rear-screen projection system assembly are common challenges for M3's technicians.



M3 performs control system programming, installation of wall-mounted displays and system infrastructure configuration.

Service Delivery

System Integration Process Overview

M3 Technology Group delivers AV System design and installation, and IT structured cabling infrastructure for connectivity of voice, data, video, and building management systems. M3 services are administered by industry-accredited professional who follow standards of practice as defined by InfoComm International and BICSI. M3 services are delivered by phase, with the following standard project flow process. Any additional steps outlined in a given project specification or deemed necessary to fulfill the scope of work outlined for the project are performed.

Planning/Programming/Design Phase: M3 sales, engineering and installation specialists will conduct and attend project meetings and site surveys; Work with project personnel to establish project schedules and produce a comprehensive project package.

Construction Phase: M3 procures, inspects and assembled project equipment and systems; conducts necessary programming; Project managers coordinate with in-field personal pre-Installation.

Installation Phase: Infrastructure, cabling and building provisions are confirmed; M3 Installation Team begins equipment and system deployment, cable terminations, in-field programming, and system testing. M3 ensures the job site is maintained in a clean format throughout all phases of Installation.

Commissioning: Equipment and system operation is verified; Test reports and punch lists are generated. Outstanding issues are resolved, documented, reported to M3.

Handover/Training/Warranty: M3 provides comprehensive technical training and instruction on all system with project personnel; Functionality is demonstrated. User proficiency is ensured; As-built system drawing/documentation package is presented; manufacturer warranty cards are provided; M3 System Warranty period begins. Additional customer service programs are activated according to selection.

M3 Technical Service & Support Services

Standard Warranty Coverage

Manufacturers' warranties are supported by M3; M3's Standard Workmanship Warranty guarantees system installations to be free of defects in hardware, cables, connectors (materials) and workmanship for a predefined period according to a given project's specification. Warranty services are performed by M3 certified staff technicians and/or approved, accredited service partners in accordance with the manufacturer and/or project specifications. M3 offers a variety of fully customizable Preventive Maintenance & Service Contracts.

Preventative Maintenance Plans

M3 offers Preventative Maintenance Plans (PMP) that deliver priority service, maintenance and training, and give customers an additional layer of security and protection with new systems. Preventative Maintenance Plans include features like:

- Complete system inspections; equipment cleaning; battery replacement; minor adjustments a/r
- New User training sessions
- Loaner equipment

- Unlimited troubleshooting

Various plan features and their options are summarized as follows:

Service Task	Standard Warranty Plan	Preventive Maintenance Program	Customizable Service Level Agreements		On-site Managed Services
			Basic	Premier	
8-5 Live Help Desk	✓	✓	✓	✓	✓
Remote Troubleshooting		✓	✓	✓	✓
Loaner Equipment		✓	✓	✓	✓
Standard shipping on warranty equipment		✓	✓	✓	✓
Express shipping on warranty equipment				✓	✓
Equipment Inventory database				✓	✓
Room setup/support					✓
Preventive Maintenance		2	2	4	Ongoing
Emergency On-site response time	ASAP	Priority	1 Day	Same Day	< 4 Hour
Training (sessions for new users)	1	1	3	4	Ongoing
Discounted Equipment upgrade (discount off MSRP)			5%	7%	10%
Contract Duration	90 - Day	1 Year	1 - 3 Year	1 - 3 Year	1 - 3 Year

Emergency Service & Service Program Options

- **M3 Help Desk:** M3 provides all warrantied customers with on-call technical support during normal business hours. M3 additionally employs an emergency escalation process and resource team for critical service needs outside of the regular business hours in accordance with the customer’s selected Service Plan, the provisions of which are outlined below.
 - Initial customer outreach is responded to immediately via phone or email contact to the M3 Help Desk, Main Service Center, Nashville, TN, 8am - 5pm (CST) Monday – Friday access. Contact info: **800-227-0717** or service@m3techgroup.com
 - Initial remote diagnosis is conducted, or on-site technician engaged.
 - Service escalation process is invoked in 2-hour response increments as needed: **Help Desk – Telephone Support – Field Tech/On-site, up to top level service management personnel.**
- **Field Service & Maintenance:** M3 provides fast, reliable technical support and a range of service programs to keep your AV and video systems performing as expected. Even the best designed systems and best-in-class equipment will likely experience trouble at some point. M3’s service plans are intended to deliver performance reliability and peace of mind.

Our 24/7 tech support line and 9-5 live help desk are manned by knowledgeable, friendly technicians who understand the critical nature of your call. Our experts can often resolve problems right over the phone, but if needed, a field service specialist can be dispatched to quickly resolve the issue on site.

Whether you want to establish a regular schedule of system maintenance, user training, or need help with equipment failure or warranty management, M3 has the right program to protect and optimize your technology assets. M3 field service and maintenance plans include:

- Customized service level agreements
 - 9-5 live help desk support & 24/7 help line
 - Customized response times/escalated emergency response
 - Training & documentation creation
 - Serial number and asset tag management
 - Warranty and end-of-life management
 - Loaner equipment
- **Remote Monitoring:** M3's remote monitoring and management provide real-time AV system control, diagnostics and programming. Remote monitoring can provide cost-saving benefits by reducing the frequency of field service calls. From our Nashville Monitoring Center we detect, diagnose, and resolve many issues before they even become apparent to our customers. We can reduce troubleshooting time and handle many regular service activities with ease through network connectivity and cloud-based solutions from our manufacturers.

We monitor and control IP devices, as well as many RS-232 based devices. This means we can track projectors, cameras, video switchers, DVRs, and more. With tie in to our central system, equipment and system data is logged, analyzed and reported on each client account. M3's remote monitoring services include:

- Active system monitoring
 - Real-time diagnostics and issue resolution
 - Remote programming and system configuration
 - Proactive maintenance
- **On-site Managed Services:** M3 can provide expert technicians at your location to manage all of your AV equipment and systems — from routine maintenance and troubleshooting to room configuration or operator assistance.

Sometimes it just makes sense to have reliable, on-site technical assistance, particularly with multiple enterprise-wide technology systems, and many different users of varying degrees of technical ability. M3's certified service representatives are available for full- or part-time deployment at your facility, ready to swiftly handle your tech support and system maintenance needs. Our specialists provide expert personal attention, performance accuracy, and system reliability. M3's on-site managed services include:

- Room setup and scheduling
- Meeting support and room operation
- Routine preventative maintenance checks
- System design support
- Training and documentation services
- AV project management

- Serial number and asset tag management
- Warranty and end-of-life management

AV System Integration Process Overview

M3 Technology Group offers the following information on its standard project flow process, which shall include any additional steps outlined in the project specification or deemed necessary to fulfill the scope of work outlined for this project.

Planning/Programming/Design Phase

M3 sales, engineering and installation specialists will:

- Conduct and attend all necessary project meetings; conduct site surveys
- Work with project designers, client representatives and others project personnel to collect necessary information for creating/executing comprehensive documentation.
- Produce a complete AV system construction drawing package according to project specifications. This drawing set serves as the construction package to be transferred to M3's project management and integration teams to begin the **Construction Phase**.
- Also during the planning stage, M3 establishes a **Master administrative project package**, which serves as the resource to M3 personnel for all details about scope of work, equipment orders, design, staffing, contact information, etc. throughout the course of the project.

Construction Phase

During the Construction Phase M3 pre-builds and tests all systems in-house prior to deployment. This ensures greater quality control, improved efficiency, and greater success rates once Installation commences.

- All project equipment is procured, inspected, and assembled in M3's pre-staging lab
- Equipment racks are populated, cabling is installed, and systems are tested
- Control system programming is performed
- System components are inventoried, stored, and readied for deployment
- Project managers coordinate with in-field personal and project representatives, and inspect site conditions in preparation of the **Installation Phase**.

Installation Phase

- Infrastructure, cabling and building provisions are confirmed prior to system delivery. Upon confirmation of site readiness, the M3 Installation Team begins equipment and system deployment, cable terminations, in-field programming, and system testing.
- M3 ensures the job site is maintained in a tidy, clean format on a daily basis throughout all phases of the installation process.

Commissioning:

- Equipment and system operation is verified. Test reports and punch lists are generated. Any outstanding issues are resolved, documented, and signed off by M3 project managers and the appropriate project representatives.

- Redlined documents and all reports are delivered to M3 for generating the as-built drawing package.

Handover/Training/Warranty

M3 provides comprehensive technical training and instruction on all systems. Upon completion of system installation M3 project representatives will conduct user training and system orientation with client personnel and other designated parties according to the project specifications.

- System functionality is demonstrated. User proficiency is ensured before project sign off.
- A comprehensive as-built system drawing/documentation package is presented to client upon completion. All manufacturer warranty cards and information are provided.
- All M3 provided end-user documentation and training materials become the property of the customer upon project completion, and are free to be duplicated and distributed as needed.

The M3 90-Day System Warranty period begins upon installation and training completion.

Warranty

Warranty Statement

Warranty services are performed by M3 Technology Group certified staff technicians and/or approved, accredited service partner in accordance with the project specifications. Pricing includes system warranty as required by project specification. Additional M3 Service Level Agreements are available upon request.

Standard Workmanship Warranty

M3 Technology Group, Inc. guarantees system installations to be free of defects in hardware, cables, connectors (materials) and workmanship for a period of 365 days from the date of completion. Completion is defined as the date of installation and training completion.

Defective materials or equipment will, at M3's option, be repaired or replaced at no cost to the owner during the warranty period, provided any work does not void the manufacturers' warranties or adversely affects the products' performance.

This Warranty does not cover problems caused by associated equipment that has been provided and/or connected by others, or damage caused by accident, misuse, abuse, theft, vandalism, improper power source, fire, flood, lightning, earthquakes, (or any other acts of God), repair, or alteration by parties other than M3. This Standard Workmanship warranty is independent of all manufacturers' warranties.

Manufacturer Warranties

For equipment purchases, the manufacturers' warranties apply, and shall be supported by M3 if said warranty period is greater than the length of the M3 Standard Workmanship Warranty. For warranty periods less than the M3 Standard Workmanship Warranty period, M3 shall be liable only for defects in a given item until the end of that period.

Preventive Maintenance & Service Contract

Preventive Maintenance & Service Contract options are provided separately. Below is a brief overview of the most commonly elected M3 service plan.

One year (PMP) Preventative Maintenance Plan Overview

For a period of 1 year The M3 PMP covers the following:

1. (2) System Inspections per year – this includes a complete system inspection for functionality, cleanliness and equipment operability. During these visits M3 will perform the following tasks:
 1. Perform a complete system inspection for functionality.
 2. Clean and inspect (as required by manufacturer) all equipment, racks, equipment fans, cables and connectors, assuring they are clean and free from defects.
 3. Replace any non-rechargeable batteries that have failed with new ones.
 4. Make minor tweaks to system to enhance performance due to equipment aging, i.e. projector optical and mechanical adjustments for optimizing image quality, peak and gain attenuation adjustments for optimizing cable lengths, and minor amplification adjustments as needed for optimizing sound quality.
 5. Perform system walk-thru with customer's representative to demonstrate service performed, system functionality, cleanliness and inform customer of any defective equipment that requires repair or replacement.
2. (1) Additional training session covering operation of the system to any new clients or employees of the customer.
3. Provide loaner equipment, if available, while system is down for emergency repair.
4. Provide a detailed service report to customer within 1 week of performed system inspection.

M3 will be available for service and support after the install. Should a need arise for service please call the **M3 Help Desk**. Should more than phone support be required, M3 can dispatch a tech to come assess the failure and determine the best course of action for repair. Response time will be dictated by the selected M3 service contract in force upon installation completion. Customers under contract receive service priority.

Please discuss service contract options with your M3 Representative.

Partial Client List

Government/Municipalities

City of Columbia
City of Forest Hills
City of Oak Hill
Clark County Emergency Operations Center
Hamilton County Emergency Operations Center
Knoxville Public Building Authority
Metropolitan Government of Nashville and Davidson County
Metropolitan Nashville Airport Authority
Montgomery County
Rockcastle County Emergency Operations Center
Rutherford County Sheriff's Office
SMDCE (Space and Missile Defense)
Tennessee Air National Guard
Tennessee Army National Guard
Tennessee Bureau of Investigation
Transportation Security Administration
US Internal Revenue Service

Related AV Project Reference, Video Walls

Government: Nashville Electric Service – Security NOC

M3 has installed a 2x4 video wall which consists of eight 55" NEC panels with Crestron DM Matrix Switcher along with audio system installed in furniture

Contact: Tim Simons | Phone: 615-330-8812 | E-mail: tsimons@nespower.com

Higher Education: Vanderbilt University Network Operations Center

M3 designed and installed a six display system for Vanderbilt allowing 15 workstation inputs to be displayed at will. This system comprises two 24x7 projectors, four 65" LCD flat panels and one 16X16 video matrix. Vanderbilt uses this NOC as a 24x7 monitoring facility of their IT network, phone systems CATV systems.

Contact: Scott Milliken | Phone: 865-574-5301 | E-mail: millikensa@ornl.gov

Government: Tennessee Army National JEOC (Joint Emergency Operations Center)

This system was design and installed by M3 Technology Group to meet the needs of a 24x7 control center for the Tennessee Army National Guard. The design consists of a 2x4 planar video wall with an additional 10 displays and control system to supplement the viewing of information from the 32 different PC inputs as well as all of the major networks. This room has been up and running and maintained by M3 for over 5 years with no down time. M3 performed one upgrade to the space in 2011.

Contact: SFC Matthew Zier, TNARNG; JFHQ, J6, Visual Information
Phone: 615-313-2621 | E-mail: matthew.j.zier.mil@mail.mil

Government: US Army Space/Missile Defense, Secure VTC Command Center

Designed and Installed 4x3 Video wall consisting of twelve 46" displays, RGB Spectrum 12x12 Video Wall Processor, Secure Polycom Video Conferencing System, HD document camera, HD Tuners, AMX control system with multiple touch panel controls and 16x16 Extron Matrix Switcher. This room allows the 3Star General to securely communicate with remote locations and other military bases and battlefields.

Contact: Jack Miller | Phone: 256-955-4363

Tennessee Army National Guard Command Conference Room

This system was design and installed by M3 Technology Group to meet the needs of the Command Conference Room for the Tennessee Army National Guard in Nashville, Tennessee. This system was designed around a Cisco VTC with a 6x2 55" Planar Video Wall. It includes a 32x16 Extron matrix switcher controlled by a Crestron control system. This system has a secondary control room with full control capabilities from two different Crestron Touch panels. The VTC system has two Cisco HD cameras and the microphone audio is handled by a ClearOne DSP. This is the main "state wide" conference room that must be ready to stand up 24x7. This room has been up and running and maintained by M3 for over 5 years with no down time. M3 performed one upgrade to the space in 2011.

Contact: SFC Matthew Zier, TNARNG; JFHQ, J6, Visual Information | Phone: 615-313-2621
E-mail: matthew.j.zier.mil@mail.mil

AV Equipment Directory

Below is a sample listing of the best-in-class manufacturers with whom M3 partners for delivering exceptional AV technology integration solutions.



AMX hardware and software solutions simplify the way people interact with technology. With the increasing number of technologies and operating platforms at work and home, AMX solves the complexity of managing this technology with reliable, consistent and scalable systems. Our award-winning products span **control and automation**, system-wide switching and audio/video signal distribution, as well as digital signage and technology management. They are implemented worldwide in conference rooms, homes, classrooms, network operation / command centers, hotels, entertainment venues and broadcast facilities, among others.



AUDIX microphones are used for a full range of applications that demand sound to be captured at a greater distance than what is expected of a stage vocal microphone.

With superior sensitivity and lower profile, AUDIX condenser microphones are the choice for gooseneck microphones for podium, courtroom, and conference room use, hanging microphones for choir or video conferencing and microphones used for measurement, USB and lapel.



Biamp products work wonders in airports, arenas, courtrooms, Houses of Worship, theaters, universities, corporations, and conference centers. Around the world, around the clock, Biamp equipment is delivering, managing and enhancing the sound.

Products include networked digital audio, application-specific audio products, networked media transport, multipurpose networked public address and **voice evacuation systems, analog amplifiers** and mixers.



BlueJeans Network is an interoperable cloud-based video conferencing service provider that facilitates a global meeting experience which allows users to connect anywhere, any time and any place, regardless of the device or platform they are using.



Conferences come in all shapes and sizes; fortunately, so do Bosch Conference Systems. From intimate informal meetings, to major multi-lingual conferences with thousands of delegates, Bosch's Conference Systems get people interacting and communicating effectively, and in a way that suits everyone.



Cambridge Sound Management, LLC (CSM) is a premiere developer of sound masking systems that offer innovative, simple and intelligently designed solutions to the problems of privacy and acoustic distractions. CSM technology combines exceptional audio performance, low impact installation, and affordability.



The Cisco Collaboration portfolio allows people to communicate in a way that is most natural to them, on the device that meets their individual requirements while providing the best video, audio and collaboration experience.

Cisco enables people to communicate in ways that are visual, virtual, mobile and social, as well as secure, standards based, and easy to manage. People can connect when, where, and how they want, and can expect a quality experience every time.



Chief, a division of Milestone AV Technologies, with 35 years of proven product and service excellence, hundreds of product awards and patented designs, is a globally recognized AV industry leader. Chief provides **ceiling, wall and specialty mounting solutions** for display and projection technologies used in commercial and home theater applications.



With over 40 years in business and 90+ offices worldwide, Crestron Electronics is the leading provider of control and automation systems for homes, offices, schools, hospitals, hotels and more. Crestron solutions are **Integrated by Design™** to provide the ultimate technology lifestyle. No matter where you are, or what you do, with Crestron you're always connected.



Da-Lite, a Milestone AV Technologies company, designs and manufactures a comprehensive line of **projection screen surfaces and projection screens** for the most demanding applications. Da-Lite's proprietary screen technologies are specified for custom installations including military training simulators, boardrooms, entertainment venues, and home theaters. Founded in 1909 and headquartered in Warsaw, Indiana, Da-Lite is the leading manufacturer of projection screens worldwide.



Whether you need an **electric, manual, rigid rear, or fixed projection screen**, Draper has the perfect screen for any application. Combine the perfect screen with the perfect control, mounting, and installation option and you have a superior product that delivers quality and performance. Draper's line of lifts and mounts offer AV solutions for almost every need. Only Draper offers such a diverse choice of video projector lifts.



Eaton is the leading provider of **ergonomic consoles** for mission-critical applications. By integrating people with technology, Eaton console designs help to manage technology-intensive **command and control environments** like Emergency Operations Centers(EOC)/Public Safety, Network Operation Centers (NOC), Process control, medical imaging, security, transportation, and trading.



ELMO presenters go further by featuring advanced technologies and concepts to enhance a wide range of communications. They are the perfect presentation tool, allowing users to easily break through the constraints and obstacles that previously seemed to hamper communication. They are easier to understand, easier to use, and best of all, it give you more power to communicate.



Epson delivers high quality projectors with excellent color brightness and innovative features for business, education and home theater. As a market leader, Epson continues to set the standards for image quality, performance and innovation with its line of multimedia projectors. All Epson projectors are based on 3-chip LCD technology for amazing color, incredible detail and solid reliability.



Extron manufactures computer-video interfaces, switchers, configurable control systems, distribution amplifiers, computer-video scan converters, scalers, signal processing equipment, **and high resolution cables**. These products are used to integrate computer, video, and audio into presentation displays for today's boardrooms, presentation/training centers, university lecture halls.



Present, annotate and collaborate on a giant tablet with meeting participants in the room and around the world. An InFocus **Mondopad** interactive display puts everything you need to visually present, capture and share ideas at your fingertips – all beautifully integrated into a single device.



Listen Technologies believes in experiencing every sound, whether it's the carefully chosen words of a tour guide or the subtleties of expression emanating from an orchestra's sting section. It's all a vital part of a full, enriching experience, and Listen is dedicated to making sure every individual hears every sound.

Listen's exclusive line of state-of-the-art **wireless listening product** and technologies offer diversity of use for auditory assistance, language interpretation, tour groups, soundfield, and conferencing – all designed to connect people to positive experiences.



Whether you are looking to reduce energy costs, increase comfort or manage light control solutions, Lutron products offer the flexibility you need with the energy savings you want.



Mitsubishi Electric Visual Solutions America manufactures and markets a complete line of display products including projectors, data wall display systems, LCD digital signage monitors and players, large-screen 3D DLP® televisions and the world's first laser TV, LaserVue®.



NEC Display Solutions designs, produces and delivers leading-edge **visual display technology** for a wide variety of markets. We specialize in **desktop and large-screen LCD displays**, and a diverse line of **projectors** for customers who demand the most high-quality, reliable display solutions to meet their needs.



Panasonic has been a global leader in innovative technology for professional and consumer applications over 50 years. Their professional line of video cameras, projectors and displays offer exceptional value and quality, and reliability.



Planar Systems Inc. (NASDAQ: PLNR) is a global leader in **digital display technology** providing premier solutions for the world's most demanding environments. Retailers, educational institutions, government agencies, businesses, utilities and energy firms, and home theater enthusiasts all depend on Planar to provide superior performance when image experience is of the highest importance. Planar solutions are used by the world's leading organizations in applications ranging from **digital signage** to simulation and from **interactive kiosks** to **large-scale data visualization**.



Polycom **video conferencing solutions** let people work from anywhere and actually engage more effectively and efficiently as a result. RealPresence video conferencing solutions help thousands of companies get business done faster, no matter where their people are.

Polycom provides comprehensive video conferencing solutions, and extends simple, affordable and secure face-to-face collaboration from boardrooms to desktops, tablets, and smartphones.



RGB Spectrum offers solutions for the display, recording, and transmission of computer and video signals. Products include **videowalls, multiPoint control room management system (MCMS), multiviewers, video codecs, scan converters, keyers/overlayers, switchers, scalers, multicast servers, digital recorders.**

Multi-screen displays in NOCs (Network Operations Centers), TOCs (Tactical Operations Centers), and EOCs (Emergency Operations Centers) as well as security control centers, entertainment systems, industrial design and retail venues. Variously called a video wall, info wall, data wall, tiled display, virtual wall, display wall, or virtual monitor wall,

our control room management systems offer real time performance, easy installation, and 24/7 reliability.



Samsung touch screen displays enable touch-sensitivity all the way to the edges of the screen. They have accurate optical sensor technology, improved touch reliability and responsive touch, even in the edges and corners. The interactive LCD whiteboard is thin so it occupies less space than conventional blackboards. Wide viewing angle ensures a great view from any seat in the room.



Sharp **LED-LCD interactive displays** provide brilliant color images for greater communication power. Superior collaborative ease with touch-screen convenience. Ideal for versatility and performance in business meetings, teleconferences, presentations, training/classroom instruction and high-impact signage.



Shure manufactures world renowned microphones for performance, recording, installed and broadcast applications. With a history of audio innovation spanning over 80 years, Shure has turned a passion for making great microphones and audio electronics into an obsession. No wonder Shure continues to set the worldwide industry standard for superior microphones and audio electronics.



SMART Technologies Inc. is a leading provider of interactive displays that enable inspired collaboration in schools and workplaces by turning group work into a highly interactive, engaging and productive experience. SMART delivers integrated solutions of hardware, software and services designed for superior performance and ease of use.



Spectrum Industries is the premier manufacturer of furnishing products that facilitate learning by incorporating innovative designs with technology and communications equipment.



Tightrope Media Systems Carousel is an intelligent digital signage **system** that is designed with simplicity, security, scalability and economy in mind. Start with a single display and expand to nearly limitless channels of signage in multiple buildings.



Vaddio is the premier global manufacturer of **pan/tilt/zoom cameras, specialty camera control systems and professional USB peripherals** for the audiovisual, videoconference and broadcast marketplaces.

In applications ranging from distance learning to corporate conferencing and television production, Vaddio products bring class-leading capabilities, convenience and flexibility to users—elevating the science of communication with the “Art of Easy.”



WolfVision GmbH Austria is the leading manufacturer of Visualizers / document cameras. Visualizers are special optoelectronic appliances designed to pick up objects on its working surface in perfect quality quickly and easily. They are mainly used for training and education and as document cameras for videoconferencing.

Manufacturer Certifications List

AMX by Harman

AMX Designer	Chris Montini	Date of Issue 10/02/2002
AMX Installer	Chris Montini	Date of Issue 12/11/2003
AMX Programming	Chris Montini	Date of Issue 10/19/2001
	Kyle Jackman	Date of Issue 08/19/2015
AMX Ace Certification	Chris Montini	Date of Issue 12/11/2013
AMX Ace Design	Nick Paton	Date of issue 6/28/2013
AMX Ace Installation	Nick Paton	Date of issue 6/28/2013
AMX Ace Programming	Nick Paton	Date of issue 12/31/2013
AMX NAM-Programming 1	Kyle Jackman	
AMX Programmer 1	Jason Taylor	Date of Issue 11/1/2002
	Todd Lewis	Date of Issue 8/15/2005
AMX Intro to Networking for AV Professionals	Todd Lewis	Date of Issue 7/15/2005

BiAmp

Audia Training	Chris Montini
Audia Training	Jason Taylor
Audia Training	Nick Woodring
Tesira Training	Nick Woodring, Todd Lewis, Kyle Jackman
Fundamentals of AVB	Phillip Cordell

BICSI

RCDD	Marcus Collins
Certified ITS Technician	Jesse Stinson, Date of issue 12/2013

Cambridge Sound Management

Certified Masking Expert	Jason Taylor
Installation Review & Commissioning	Chris Montini

Cisco

Select Partner	M3 Technology Group
Technical Training	Phillip Cordell
	Chris Montini
	Nick Woodring

ClearOne

Certified Product Specialist	Todd Lewis
-------------------------------------	------------

Professional Audio Conferencing Specialist

Certification Kyle Jackman

Commscope

SPUCI – Uniprise Certified Installer Marcus Collins

Crestron

CTI-P201 Core Programming Kyle Jackman

DMC-D-4K Todd Lewis, Kyle Jackman

DMC-E-4K Todd Lewis

DMC-T-4K Kyle Jackman

DMC-D Todd Lewis
Collin McGinley

DMC-E Todd Lewis

DMC-T Dan Burgess
Phillip Cordell
Matt Ferguson
Kyle Jackman
Todd Lewis
Chris Montini
Ben Moore
Nick Paton
Will Pettus
Robert Simmons
Jonathan Starnes
Jason Taylor
Dustin Waldrop
Aaron White
Nick Woodring

Essentials of Programming Dan Burgess
Phillip Cordell
Kyle Jackman
Todd Lewis
Nick Paton
Jason Taylor

Intermediate Programming Dan Burgess
Phillip Cordell
Kyle Jackman
Nick Paton

Advanced Programming Jason Taylor
Dan Burgess

Extron

AV Tech for Systems Designers

Phillip Cordell
Todd Lewis
Chris Montini
Jason Taylor
Nick Woodring

Configurable Control Systems

Chris Montini
Will Pettus
Nick Woodring

School of Audio Visual Technologies

Dan Burgess

InfoComm

APEX Certified AV

Solutions Provider

CTS

M3 Technology Group

Phillip Cordell

Larry Jackson

Kyle Jackman

Emil Metzger

Jonathan Moore

Collin McGinley

Jason Taylor

Nick Woodring

Chris Montini

CTS-D

Phillip Cordell... Expires 1/31/2016

Jason Taylor Expires 6/30/2016

CTS-I

Jason Taylor Expires 4/30/2015

Nick Woodring . Expires 2/27/2018

Will Pettus..... Expires 2/27/2018

Dustin Waldrop Expires 2/27/2018

Hubbell

Premise Wiring's Mission Critical ® certified

Jeff Brown

Marcus Collins

Rick Collins

Aaron Goodin

James Maddle

Shane McIntire

Jesse Stinson

KBZ Communications/Cisco Training

Selling Infrastructure Phillip Cordell
Jason Taylor
Nick Woodring

Optical Cable Corp

MDIS Certification Marcus Collins
Matt Ferguson
Scott Green
Kyle Jackman
Collin McGinley
Jonathan Starnes
Jessie Stinson
David West

Copper/Fiber Jonathan Starnes
Jesse Stinson

PolyCom

Assessment RealPresence Platform Technical Level 1RPPEXOT104 .. Kyle Jackman
Experience RealPresence Collaboration Server RPPCSOS103 Kyle Jackman
Experience RealPresence CloudAXIS Suite RPCAIOS102 Kyle Jackman
Federal Certification FSIST300 Chris Montini
HD Telepresence Technologies Will Pettus, Nick Woodring
Installed Voice Pre-Sales Tech Training Chris Montini
Installed Voice Solution Sales Track IVOS100 Chris Montini
Installed Voice Solution Technical Track IVOT200 Chris Montini
RealPresence Platform Technical Certification RPPOT200..... Kyle Jackman
Video Solutions Pre-Sales Tech Training Chris Montini
Video Solutions Sales Training..... Chris Montini

BICSI

RCDD Marcus Collins

RevoLabs

Installing Wireless Systems Chris Montini

Volante /SVSi

**Networked AV Dist
and Infrastructure Design** Todd Lewis

Yamaha

Commercial Audio M7CL

Training School

Nick Woodring

Authorized Service Center

M3 Technology Group coordinates with all of its manufacturer's service centers on behalf of clients.

Computer Software Systems

- AutoCad 2013
- Adobe CS5 Suite
- Microsoft Office

System Test Equipment

- Extron VTG 400DVI
- Test-UM LanRover PRO TP600 Network Tool/Tester
- Fluke DTX 1800 with single and multi-mode fiber modules
- Leader LD 941D Signal level meter
- Sound Device USB pre-amp Audix TM271 calibrated mic and SmartLive Calibration software for room tuning