

Bid No.: 5-2018

Bid Opening: February 14, 2018 2:00 PM

VaOpto is pleased to respond to the Lexington-Fayette Urban County Government Invitation to Bid #5-2018. Enclosed are the signed and notarized bid documents. Also enclosed are the completed Extract worksheet and our product specifications. VaOpto will be manufacturing all products for the bid in our factory.

VaOpto is a 100% US Citizen Minority-Owned LED manufacturer, founded in the State of Virginia in 2005, and relocated to Las Vegas, Nevada in 2010. VAOPTO specializes in LED R&D, manufacturing, and wholesale with OEM and ODM services. Our world-class manufacturing facilities are ISO14001 / ISO9001 / TS16949 / OHSAS18001 certified and RoHS compliant. VaOpto provides components, lightings, and application systems for LED-related industries with high quality, superior performance, and competitive prices.

Please feel free to contact me with any questions or concerns that you may have.

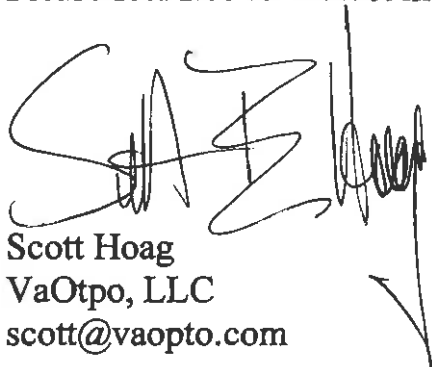

Scott Hoag
VaOpto, LLC
scott@vaopto.com



LEXINGTON

Lexington-Fayette Urban County Government

Lexington, Kentucky
Horse Capital of the World

Division of Central Purchasing

Date of Issue: January 24, 2018

INVITATION TO BID #5-2018 LED Lighting Fixtures

Bid Opening Date: February 14, 2018

Bid Opening Time: 2:00 PM

Address: 200 East Main Street, 3rd Floor, Room 338, Lexington, Kentucky 40507

Type of Bid: Price Contract

Pre Bid Meeting: N/A

Pre Bid Time: N/A

Address: N/A

Sealed bids will be received in the office of the Division of Central Purchasing, 200 East Main Street, Lexington, Kentucky, until **2:00 PM**, prevailing local time on **02/14/2018**. Bids must be received by the above-mentioned date and time. Mailed bids should be sent to:

**Division of Central Purchasing
200 East Main Street, Room 338
Lexington, KY 40507, (859) 258-3320**

The Lexington-Fayette Urban County Government assumes no responsibility for bids that are not addressed and delivered as indicated above. **Bids that are not delivered to the Division of Central Purchasing by the stated time and date will be rejected.** All bids must be signed and have the company name and address, bid invitation number, and the name of the bid on the outside of the envelope.

Bids are to include all shipping costs to the point of delivery located at: Various LFUCG locations

Check One: Bid Specifications Met <input checked="" type="checkbox"/> Exceptions to Bid Specifications. <i>Exceptions shall be itemized and attached to bid proposal submitted.</i>		Proposed Delivery: <u>60</u> days after acceptance of bid.
Procurement Card Usage —The Lexington-Fayette Urban County Government may be using Procurement Cards to purchase goods and services and also to make payments. Will you accept Procurement Cards?		
<input checked="" type="checkbox"/> Yes		<input type="checkbox"/> No

Submitted by: VaOpto, LLC

Firm Name
5178 W. Patrick

Address
Las Vegas, NV 89118

City, State & Zip

Bid must be signed:
(original signature) Signature of Authorized Company Representative – Title

Charles Li
Representative's Name (Typed or printed)
702-517-5789

Area Code - Phone – Extension *Fax #*

charles.li@vaopto.com

E-Mail Address

AFFIDAVIT

Comes the Affiant, Charles Li, and after being first duly sworn under penalty of perjury as follows:

1. His/her name is Charles Li and he/she is the individual submitting the bid or is the authorized representative of VaOpto, LLC the entity submitting the bid (hereinafter referred to as "Bidder")
2. Bidder will pay all taxes and fees, which are owed to the Lexington-Fayette Urban County Government at the time the bid is submitted, prior to award of the contract and will maintain a "current" status in regard to those taxes and fees during the life of the contract.
3. Bidder will obtain a Lexington-Fayette Urban County Government business license, if applicable, prior to award of the contract.
4. Bidder has authorized the Division of Central Purchasing to verify the above-mentioned information with the Division of Revenue and to disclose to the Urban County Council that taxes and/or fees are delinquent or that a business license has not been obtained.
5. Bidder has not knowingly violated any provision of the campaign finance laws of the Commonwealth of Kentucky within the past five (5) years and the award of a contract to the Bidder will not violate any provision of the campaign finance laws of the Commonwealth.
6. Bidder has not knowingly violated any provision of Chapter 25 of the Lexington-Fayette Urban County Government Code of Ordinances, known as "Ethics Act."
7. Bidder acknowledges that "knowingly" for purposes of this Affidavit means, with respect to conduct or to circumstances described by a statute or ordinance defining an offense, that a person is aware or should have been aware that his conduct is of that nature or that the circumstance exists.

Further, Affiant sayeth naught.

Charles Li

STATE OF Nevada

COUNTY OF Clark

The foregoing instrument was subscribed, sworn to and acknowledged before me by Charles Qiang Li on this the 9th day of February, 2018.

My Commission expires: June 24th, 2019

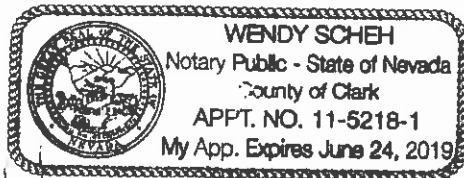

Wendy Scheh
NOTARY PUBLIC, STATE AT LARGE

Please refer to Section II. Bid Conditions, Item "U" prior to completing this form.

I. GREEN PROCUREMENT

A. ENERGY

The Lexington-Fayette Urban County Government is committed to protecting our environment and being fiscally responsible to our citizens.

The Lexington-Fayette Urban County Government mandates the use of Energy Star compliant products if they are available in the marketplace (go to www.Energystar.gov). If these products are available, but not submitted in your pricing, your bid will be rejected as non-compliant.

ENERGY STAR is a government program that offers businesses and consumers energy-efficient solutions, making it easy to save money while protecting the environment for future generations.

Key Benefits

These products use 25 to 50% less energy
Reduced energy costs without compromising quality or performance
Reduced air pollution because fewer fossil fuels are burned
Significant return on investment
Extended product life and decreased maintenance

B. GREEN SEAL CERTIFIED PRODUCTS

The Lexington-Fayette Urban County Government is also committed to using other environmentally friendly products that do not negatively impact our environment. Green Seal is a non-profit organization devoted to environmental standard setting, product certification, and public education.

Go to www.GreenSeal.org to find available certified products. These products will have a reduced impact on the environment and on human health. The products to be used must be pre-approved by the LFUCG prior to commencement of any work in any LFUCG facility. If a Green Seal product is not available, the LFUCG must provide a signed waiver to use an alternate product. Please provide information on the Green Seal products being used with your bid response.

C. GREEN COMMUNITY

The Lexington-Fayette Urban County Government (LFUCG) serves as a principal, along with the University of Kentucky and Fayette County Public Schools, in the Bluegrass Partnership for a Green Community. The Purchasing Team component of the Partnership collaborates on economy of scale purchasing that promotes and enhances environmental initiatives. Specifically, when applicable, each principal is interested in obtaining best value products and/or services which promote environment initiatives via solicitations and awards from the other principals.

If your company is the successful bidder on this Invitation For Bid, do you agree to extend the same product/service pricing to the other principals of the Bluegrass Partnership for a Green Community (i.e. University of Kentucky and Fayette County Schools) if requested?

Yes No

II. Bid Conditions

- A. No bid may be withdrawn for a period of sixty (60) days after the date and time set for opening.
- B. No bid may be altered after the date and time set for opening. In the case of obvious errors, the Division of Central Purchasing may permit the withdrawal of a bid. The decision as to whether a bid may be withdrawn shall be that of the Division of Central Purchasing.
- C. Acceptance of this proposal shall be enactment of an Ordinance by the Urban County Council.
- D. The bidder agrees that the Urban County Government reserves the right to reject any and all bids for either fiscal or technical reasons, and to award each part of the bid separately or all parts to one vendor.
- E. Minor exceptions may not eliminate the bidder. The decision as to whether any exception is minor shall be entirely that of the head of the requisitioning Department or Division and the Director of the Division of Central Purchasing. The Urban County Government may waive technicalities and informalities where such waiver would best serve the interests of the Urban County Government.
- F. Manufacturer's catalogue numbers, trade names, etc., where shown herein are for descriptive purposes and are to guide the bidder in interpreting the standard of quality, design, and performance desired, and shall not be construed to exclude proposals based on furnishing other types of materials and/or services. However, any substitution or departure proposed by the bidder must be clearly noted and described; otherwise, it will be assumed that the bidder intends to supply items specifically mentioned in this Invitation for Bids.
- G. The Urban County Government may require demonstrations of the materials proposed herein prior to acceptance of this proposal.
- H. Bids must be submitted on this form and must be signed by the bidder or his authorized representative. Unsigned bids will not be considered.
- I. Bids must be submitted prior to the date and time indicated for opening. Bids submitted after this time will not be considered.
- J. All bids mailed must be marked on the face of the envelope:

"Bid on #5-2018 LED Lighting Fixtures"

and addressed to: Division of Central Purchasing
 200 East Main Street, Room 338
 Lexington, Kentucky 40507

The Lexington-Fayette Urban County Government assumes no responsibility for bids that are not addressed and delivered as indicated above. Bids that are not delivered to the Division of Central Purchasing by the stated time and date will be rejected.

- K. Bidder is requested to show both unit prices and lot prices. In the event of error, the unit price shall prevail.
- L. A certified check or Bid Bond in the amount of XX percent of the bid price must be attached hereto. This check must be made payable to the Lexington-Fayette Urban County Government, and will be returned when the material and/or services specified herein have been delivered in accordance with specifications. In the event of failure to perform within the time period set forth in this bid, it is agreed the certified check may be cashed and the funds retained by the Lexington-Fayette Urban County Government as liquidated damages. Checks of unsuccessful bidders will be returned when the bid has been awarded.
- M. The delivery dates specified by bidder may be a factor in the determination of the successful bidder.
- N. Tabulations of bids received may be mailed to bidders. Bidders requesting tabulations must enclose a stamped, self-addressed envelope with the bid.
- O. The Lexington-Fayette Urban County Government is exempt from Kentucky Sales Tax and Federal Excise Tax on materials purchased from this bid invitation. Materials purchased by the bidder for construction

projects are not tax exempt and are the sole responsibility of the bidder.

- P. All material furnished hereunder must be in full compliance with OSHA regulations.
- Q. If more than one bid is offered by one party, or by any person or persons representing a party, all such bids shall be rejected.
- R. Signature on the face of this bid by the Bidder or his authorized representative shall be construed as acceptance of and compliance with all terms and conditions contained herein.
- S. The Entity (regardless of whether construction contractor, non-construction contractor or supplier) agrees to provide equal opportunity in employment for all qualified persons, to prohibit discrimination in employment because of race, color, creed, national origin, sex or age, and to promote equal employment through a positive, continuing program from itself and each of its sub-contracting agents. This program of equal employment opportunity shall apply to every aspect of its employment policies and practices.
- T. The Kentucky Equal Employment Opportunity Act of 1978 (KRS 45.560-45.640) requires that any county, city, town, school district, water district, hospital district, or other political subdivision of the state shall include in directly or indirectly publicly funded contracts for supplies, materials, services, or equipment hereinafter entered into the following provisions:

During the performance of this contract, the contractor agrees as follows:

- (1) The contractor will not discriminate against any employee or applicant for employment because of race, color, religion, sex, age or national origin;*
- (2) The contractor will state in all solicitations or advertisements for employees placed by or on behalf of the contractors that all qualified applicants will receive consideration for employment without regard to race, color, religion, sex, age or national origin;*
- (3) The contractor will post notices in conspicuous places, available to employees and applicants for employment, setting forth the provisions of the non-discrimination clauses required by this section; and*
- (4) The contractor will send a notice to each labor union or representative of workers with which he has a collective bargaining agreement or other contract or understanding advising the labor union or workers' representative of the contractor's commitments under the nondiscrimination clauses.*

The Act further provides:

KRS 45.610. Hiring minorities - Information required

- (1) For the length of the contract, each contractor shall hire minorities from other sources within the drawing area, should the union with which he has collective bargaining agreements be unwilling to supply sufficient minorities to satisfy the agreed upon goals and timetable.*
- (2) Each contractor shall, for the length of the contract, furnish such information as required by KRS 45.560 to KRS 45.640 and by such rules, regulations and orders issued pursuant thereto and will permit access to all books and records pertaining to his employment practices and work sites by the contracting agency and the department for purposes of investigation to ascertain compliance with KRS 45.560 to 45.640 and such rules, regulations and orders issued pursuant thereto.*

KRS 45.620. Action against contractor - Hiring of minority contractor or subcontractor

- (1) If any contractor is found by the department to have engaged in an unlawful practice under this chapter during the course of performing under a contract or subcontract covered under KRS 45.560 to 45.640, the department shall so certify to the contracting agency and such certification shall be binding upon the contracting agency unless it is reversed in the course of judicial review.*
- (2) If the contractor is found to have committed an unlawful practice under KRS 45.560 to 45.640, the contracting agency may cancel or terminate the contract, conditioned upon a program for future compliance approved by the contracting agency and the department. The contracting agency may*

declare such a contractor ineligible to bid on further contracts with that agency until such time as the contractor complies in full with the requirements of KRS 45.560 to 45.640.

- (3) *The equal employment provisions of KRS 45.560 to 45.640 may be met in part by a contractor by subcontracting to a minority contractor or subcontractor. For the provisions of KRS 45.560 to 45.640, a minority contractor or subcontractor shall mean a business that is owned and controlled by one or more persons disadvantaged by racial or ethnic circumstances.*

KRS 45.630 Termination of existing employee not required, when

Any provision of KRS 45.560 to 45.640 notwithstanding, no contractor shall be required to terminate an existing employee upon proof that that employee was employed prior to the date of the contract.

KRS 45.640 Minimum skills

Nothing in KRS 45.560 to 45.640 shall require a contractor to hire anyone who fails to demonstrate the minimum skills required to perform a particular job.

It is recommended that all of the provisions above quoted to be included as special conditions in each contract. In the case of a contract exceeding \$250,000, the contractor is required to furnish evidence that his work-force in Kentucky is representative of the available work-force in the area from which he draws employees, or to supply an Affirmative Action plan which will achieve such representation during the life of the contract.

- U. Any party, firm or individual submitting a proposal pursuant to this invitation must be in compliance with the requirements of the Lexington-Fayette Urban County Government regarding taxes and fees before they can be considered for award of this invitation and must maintain a "current" status with regard to those taxes and fees throughout the term of the contract. The contractor must be in compliance with Chapter 13 from the Code of Ordinances of the Lexington-Fayette Urban County Government. The contractor must be in compliance with Ordinance 35-2000 pursuant to contractor registration with the Division of Building Inspection. If applicable, said business must have a Fayette County business license.

Pursuant to KRS 45A.343 and KRS 45A.345, the contractor shall

- (1) *Reveal any final determination of a violation by the contractor within the previous five year period pursuant to KRS Chapters 136 (corporation and utility taxes), 139 (sales and use taxes), 141 (income taxes), 337 (wages and hours), 338 (occupational safety and health of employees), 341 (unemployment and compensation) and 342 (labor and human rights) that apply to the contractor; and*
- (2) *Be in continuous compliance with the above-mentioned KRS provisions that apply to the contractor for the duration of the contract.*

A contractor's failure to reveal the above or to comply with such provisions for the duration of the contract shall be grounds for cancellation of the contract and disqualification of the contractor from eligibility for future contracts for a period of two (2) years.

- V. Vendors who respond to this invitation have the right to file a notice of contention associated with the bid process or to file a notice of appeal of the recommendation made by the Director of Central Purchasing resulting from this invitation.

Notice of contention with the bid process must be filed within 3 business days of the bid/proposal opening by (1) sending a written notice, including sufficient documentation to support contention, to the Director of the Division of Central Purchasing or (2) submitting a written request for a meeting with the Director of Central Purchasing to explain his/her contention with the bid process. After consulting with the Commissioner of Finance the Chief Administrative Officer and reviewing the documentation and/or hearing the vendor, the Director of Central Purchasing shall promptly respond in writing findings as to the compliance with bid processes. If, based on this review, a bid process irregularity is deemed to have occurred the Director of Central Purchasing will consult with the Commissioner of Finance, the Chief Administrative Officer and the Department of Law as to the appropriate remedy.

Notice of appeal of a bid recommendation must be filed within 3 business days of the bid recommendation by (1) sending a written notice, including sufficient documentation to support appeal, to the Director, Division of Central Purchasing or (2) submitting a written request for a meeting with the Director of Central Purchasing to explain his appeal. After reviewing the documentation and/or hearing the vendor and consulting with the Commissioner of Finance and the Chief Administrative Officer, the Director of Central Purchasing shall in writing, affirm or withdraw the recommendation.

III. Procurement Contract Bid Conditions

- A. The terms of this agreement shall be for 1 year(s) from the date of acceptance of this contract by the Lexington-Fayette Urban County Government. This agreement may be automatically extended for an additional 1 year(s) renewal. This contract may be canceled by either party thirty (30) days after delivery by canceling party of written notice of intent to cancel to the other contracting party.
- B. Price Changes **(Space Checked Applies)**
 - (XXX) 1. Prices quoted in response to the Invitation shall be firm prices for the first 90 days of the Procurement Contract. After 90 days, prices may be subject to revision and such changes shall be based on general industry changes. Revision may be either increases or decreases and may be requested by either party. There will be no more than one (1) price adjustment per quarter. Requests for price changes shall be received in writing at least twenty (20) days prior to the effective date and are subject to written acceptance before becoming effective. Proof of the validity of a request for revision shall be responsibility of the requesting party. The Lexington-Fayette Urban County Government shall receive the benefit of any decline that the seller shall offer his other accounts.
 - () 2. No provision for price change is made herein. Prices are to be firm for the term of this contract.
 - () 3. See bid specifications.
- C. If any contract item is not available from the vendor, the Lexington-Fayette Urban County Government, at its option, may permit the item to be back-ordered or may procure the item on the open market.
- D. All invoices must bear reference to the Lexington-Fayette Urban County Government Purchasing document numbers which are being billed.
- E. This contract may be canceled by the Lexington-Fayette Urban County Government if it is determined that the Bidder has failed to perform under the terms of this agreement, such cancellation to be effective upon receipt of written notice of cancellation by the Bidder.
- F. No substitutions for articles specified herein may be made without prior approval of the Division of Central Purchasing.

EQUAL OPPORTUNITY AGREEMENT

Standard Title VI Assurance

The Lexington Fayette-Urban County Government, (hereinafter referred to as the "Recipient") hereby agrees that as a condition to receiving any Federal financial assistance from the U.S. Department of Transportation, it will comply with Title VI of the Civil Rights Act of 1964, 78Stat.252, 42 U.S.C. 2000d-4 (hereinafter referred to as the "Act"), and all requirements imposed by or pursuant to Title 49, Code of Federal Regulations, U.S. Department of Transportation, Subtitle A, Office of the Secretary, (49 CFR, Part 21) Nondiscrimination in Federally Assisted Program of the Department of Transportation – Effectuation of Title VI of the Civil Rights Act of 1964 (hereinafter referred to as the "Regulations") and other pertinent directives, no person in the United States shall, on the grounds of race, color, national origin, sex, age (over 40), religion, sexual orientation, gender identity, veteran status, or disability be excluded from participation in, be denied the benefits of, or be otherwise subjected to discrimination under any program or activity for which the Recipient receives Federal financial assistance from the U.S. Department of Transportation, including the Federal Highway Administration, and hereby gives assurance that will promptly take any necessary measures to effectuate this agreement. This assurance is required by subsection 21.7(a) (1) of the Regulations.

The Law

- Title VII of the Civil Rights Act of 1964 (amended 1972) states that it is unlawful for an employer to discriminate in employment because of race, color, religion, sex, age (40-70 years) or national origin.
- Executive Order No. 11246 on Nondiscrimination under Federal contract prohibits employment discrimination by contractor and sub-contractor doing business with the Federal Government or recipients of Federal funds. This order was later amended by Executive Order No. 11375 to prohibit discrimination on the basis of sex.
- Section 503 of the Rehabilitation Act of 1973 states: *The Contractor will not discriminate against any employee or applicant for employment because of physical or mental disability.*
- Section 2012 of the Vietnam Era Veterans Readjustment Act of 1973 requires Affirmative Action on behalf of disabled veterans and veterans of the Vietnam Era by contractors having Federal contracts.
- Section 206(A) of Executive Order 12086, Consolidation of Contract Compliance Functions for Equal Employment Opportunity, states: *The Secretary of Labor may investigate the employment practices of any Government contractor or sub-contractor to determine whether or not the contractual provisions specified in Section 202 of this order have been violated.*

The Lexington-Fayette Urban County Government practices Equal Opportunity in recruiting, hiring and promoting. It is the Government's intent to affirmatively provide employment opportunities for those individuals who have previously not been allowed to enter into the mainstream of society. Because of its importance to the local Government, this policy carries the full endorsement of the Mayor, Commissioners, Directors and all supervisory personnel. In following this commitment to Equal Employment Opportunity and because the Government is the benefactor of the Federal funds, it is both against the Urban County Government policy and illegal for the Government to let contracts to companies which knowingly or unknowingly practice discrimination in their employment practices. Violation of the above mentioned ordinances may cause a contract to be canceled and the contractors may be declared ineligible for future consideration.

Please sign this statement in the appropriate space acknowledging that you have read and understand the provisions contained herein. Return this document as part of your application packet.

Bidders

I/We agree to comply with the Civil Rights Laws listed above that govern employment rights of minorities, women, veteran status, disability and age.

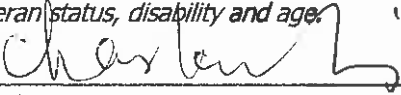

Signature

VaOpto, LLC

Name of Business

GENERAL PROVISIONS OF BID CONTRACT

By signing the below, bidder acknowledges that it understands and agrees with the following provisions related to its bid response and the provision of any goods or services to LFUCG upon selection by LFUCG pursuant to the bid request:

1. Bidder shall comply with all Federal, State & Local regulations concerning this type of service or good. All applicable state laws, ordinances and resolutions (including but not limited to Section 2-33 (Discrimination due to sexual orientation or gender identity) and Chapter 13 (Licenses and Regulations) of the Lexington-Fayette Urban County Government Code of Ordinances, and Resolution No. 484-17 (Minority, Women, and Veteran-Owned Businesses)) and the regulations of all authorities having jurisdiction over the project shall apply to the contract, and shall be deemed to be incorporated herein by reference.
2. Failure to submit ALL forms and information required by LFUCG may be grounds for disqualification.
3. Addenda: All addenda and IonWave Q&A, if any, must be considered by the bidder in making its response, and such addenda shall be made a part of the requirements of the bid contract. Before submitting a bid response, it is incumbent upon bidder to be informed as to whether any addenda have been issued, and the failure of the bidder to cover any such addenda may result in disqualification of that response.
4. Bid Reservations: LFUCG reserves the right to reject any or all bid responses, to award in whole or part, and to waive minor immaterial defects in proposals. LFUCG may consider any alternative proposal that meets its basic needs.
5. Liability: LFUCG is not responsible for any cost incurred by bidder in the preparation of its response.
6. Changes/Alterations: Bidder may change or withdraw a proposal at any time prior to the opening; however, no oral modifications will be allowed. Only letters, or other formal written requests for modifications or corrections of a previously submitted proposal which is addressed in the same manner as the bid response, and received by LFUCG prior to the scheduled closing time for receipt of bids, will be accepted. The bid response when opened, will then be corrected in accordance with such written request(s), provided that the written request is contained in a sealed envelope which is plainly marked "modifications of bid response".
7. Clarification of Submittal: LFUCG reserves the right to obtain clarification of any point in a bid or to obtain additional information from any bidder.
8. Bribery Clause: By his/her signature on its response, bidder certifies that no employee of his/hers, any affiliate or subcontractor, has bribed or attempted to bribe an officer or employee of the LFUCG.
9. Additional Information: While not necessary, the bidder may include any product brochures, software documentation, sample reports, or other documentation that may assist LFUCG in better understanding and evaluating the bid response. Additional documentation shall not serve as a substitute for other documentation which is required by the LFUCG to be submitted with the bid response.
10. Ambiguity, Conflict or other Errors: If a bidder discovers any ambiguity, conflict, discrepancy, omission or other error in the bid request of LFUCG, it shall immediately notify LFUCG of such error in writing and request modification or clarification of the document if allowable by the LFUCG.
11. Agreement to Bid Terms: In submitting its bid response, the bidder agrees that it has carefully examined the specifications and all provisions relating to LFUCG's bid request, including but not limited to the bid contract. By submission of its bid response, bidder states that it understands the meaning, intent and requirements of LFUCG's bid request and agrees to the same. The successful bidder shall warrant that it is familiar with and understands all provisions herein and shall warrant that it can comply with them. No additional compensation to bidder shall be authorized for services, expenses, or goods reasonably covered under these provisions that the bidder omits from its bid response.
12. Cancellation: LFUCG may unilaterally terminate the bid contract with the selected bidder(s) at any time, with

or without cause, by providing at least thirty (30) days advance written notice unless a different advance written notice period is negotiated prior to contract approval. Payment for services or goods received prior to termination shall be made by the LFUCG provided these goods or services were provided in a manner acceptable to the LFUCG. Payment for those goods and services shall not be unreasonably withheld.

13. **Assignment of Contract:** The selected bidder(s) shall not assign or subcontract any portion of the bid contract with LFUCG without the express written consent of LFUCG. Any purported assignment or subcontract in violation hereof shall be void. It is expressly acknowledged that LFUCG shall never be required or obligated to consent to any request for assignment or subcontract; and further that such refusal to consent can be for any or no reason, fully within the sole discretion of LFUCG.
14. **No Waiver:** No failure or delay by LFUCG in exercising any right, remedy, power or privilege hereunder, nor any single or partial exercise thereof, nor the exercise of any other right, remedy, power or privilege shall operate as a waiver hereof or thereof. No failure or delay by LFUCG in exercising any right, remedy, power or privilege under or in respect of this bid proposal or bid contract shall affect the rights, remedies, powers or privileges of LFUCG hereunder or shall operate as a waiver thereof.
15. **Authority to do Business:** Each bidder must be authorized to do business under the laws of the Commonwealth of Kentucky and must be in good standing and have full legal capacity to provide the goods or services specified in the bid proposal. Each bidder must have all necessary right and lawful authority to submit the bid response and enter into the bid contract for the full term hereof including any necessary corporate or other action authorizing the bidder to submit the bid response and enter into this bid contract. If requested, the bidder will provide LFUCG with a copy of a corporate resolution authorizing this action and/or a letter from an attorney confirming that the proposer is authorized to do business in the Commonwealth of Kentucky. All bid responses must be signed by a duly authorized officer, agent or employee of the bidder.
16. **Governing Law:** This bid request and bid contract shall be governed by and construed in accordance with the laws of the Commonwealth of Kentucky. In the event of any proceedings regarding this matter, the bidder agrees that the venue shall be the Fayette County Circuit Court or the U.S. District Court for the Eastern District of Kentucky, Lexington Division and that the bidder expressly consents to personal jurisdiction and venue in such Court for the limited and sole purpose of proceedings relating to these matters or any rights or obligations arising thereunder.
17. **Ability to Meet Obligations:** Bidder affirmatively states that there are no actions, suits or proceedings of any kind pending against bidder or, to the knowledge of the bidder, threatened against the bidder before or by any court, governmental body or agency or other tribunal or authority which would, if adversely determined, have a materially adverse effect on the authority or ability of bidder to perform its obligations under this bid response or bid contract, or which question the legality, validity or enforceability hereof or thereof.
18. **Price Discrepancy:** In case of price discrepancy, unit bid price written in words will prevail followed by unit price written in numbers then total amount bid per line item.
19. Bidder understands and agrees that its employees, agents, or subcontractors are not employees of LFUCG for any purpose whatsoever. Bidder is an independent contractor at all times related to the bid response or bid contract.
20. If any term or provision of this bid contract shall be found to be illegal or unenforceable, the remainder of the contract shall remain in full force and such term or provision shall be deemed stricken.

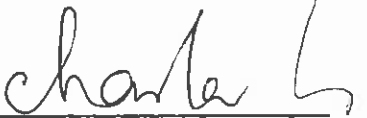
Signature

2/9/2018
Date

WORKFORCE ANALYSIS FORM

Name of Organization: VaOpto, LLC

Categories	Total	White (Not Hispanic or Latino)		Hispanic or Latino		Black or African-American (Not Hispanic or Latino)		Native Hawaiian and Other Pacific Islander (Not Hispanic or Latino)		Asian (Not Hispanic or Latino)		American Indian or Alaskan Native (not Hispanic or Latino)		Two or more races (Not Hispanic or Latino)		Total	
		M	F	M	F	M	F	M	F	M	F	M	F	M	F	M	F
Administrators										1	1						
Professionals		1								1							
Superintendents																	
Supervisors																	
Foremen																	
Technicians																	
Protective Service																	
Para-Professionals																	
Office/Clerical																	
Skilled Craft																	
Service/Maintenanc																	
Total:																	

Prepared by: Scott Hoag, Governments Sales Date: 2 / 9 / 2018
(Name and Title) *Revised 2015-Dec-15*

**DIRECTOR, DIVISION OF CENTRAL PURCHASING
LEXINGTON-FAYETTE URBAN COUNTY GOVERNMENT
200 EAST MAIN STREET
LEXINGTON, KENTUCKY 40507**

**NOTICE OF REQUIREMENT FOR AFFIRMATIVE ACTION TO ENSURE
EQUAL EMPLOYMENT OPPORTUNITIES AND DBE CONTRACT PARTICIPATION**

The Lexington-Fayette Urban County Government has set a goal that not less than ten percent (10%) of the total value of this contract be subcontracted to MBE/WBE's, and set a goal that not less than three percent (3%) of the total value of this contract be subcontracted to Veteran-Owned Small Businesses. The goal for the utilization of Certified MBE/WBE's and Veteran-Owned Small Businesses as subcontractors are recommended goals. Contractors who fail to meet such goals will be expected to provide written explanations to the Director of the Division of Central Purchasing of efforts they have made to accomplish the recommended goals and the extent to which they are successful in accomplishing the recommended goals will be a consideration in the procurement process.

For assistance in locating MBE/WBE Subcontractors contact Sherita Miller at 859/258-3320 or by writing the address listed below:

Sherita Miller, Division of Central Purchasing
Lexington-Fayette Urban County Government
200 East Main Street – Room 338
Lexington, Kentucky 40507
smiller@lexingtonky.gov

Lexington-Fayette Urban County Government
MWDBE PARTICIPATION GOALS

A. GENERAL

- 1) The LFUCG request all potential contractors to make a concerted effort to include Minority-Owned (MBE), Woman-Owned (WBE), Disadvantaged (DBE) Business Enterprises and Veteran-Owned Small Businesses (VOSB) as subcontractors or suppliers in their bids.
- 2) Toward that end, the LFUCG has established 10% of total procurement costs as a Goal for participation of Minority-Owned, Woman-Owned and Disadvantaged Businesses on this contract.
- 3) **It is therefore a request of each Bidder to include in its bid, the same goal (10%) for MWDBE participation and other requirements as outlined in this section.**
- 4) The LFUCG has also established a 3% of total procurement costs as a Goal for participation for of Veteran-Owned Businesses.
- 5) **It is therefore a request of each Bidder to include in its bid, the same goal (3%) for Veteran-Owned participation and other requirements as outlined in this section.**

B. PROCEDURES

- 1) The successful bidder will be required to report to the LFUCG, the dollar amounts of all payments submitted to Minority-Owned, Woman-Owned or Veteran-Owned subcontractors and suppliers for work done or materials purchased for this contract. (See Subcontractor Monthly Payment Report)
- 2) Replacement of a Minority-Owned, Woman-Owned or Veteran-Owned subcontractor or supplier listed in the original submittal must be requested in writing and must be accompanied by documentation of Good Faith Efforts to replace the subcontractor / supplier with another MWDBE Firm; this is subject to approval by the LFUCG. (See LFUCG MWDBE Substitution Form)
- 3) For assistance in identifying qualified, certified businesses to solicit for potential contracting opportunities, bidders may contact:
 - a) The Lexington-Fayette Urban County Government, Division of Central Purchasing (859-258-3320)
- 4) The LFUCG will make every effort to notify interested MWDBE and Veteran-Owned subcontractors and suppliers of each Bid Package, including information on the scope of work, the pre-bid meeting time and location, the bid date, and all other pertinent information regarding the project.

C. DEFINITIONS

- 1) A Minority-Owned Business Enterprise (MBE) is defined as a business which is certified as being at least 51% owned, managed and controlled by persons of African American, Hispanic, Asian, Pacific Islander, American Indian or Alaskan Native Heritage.
- 2) A Woman-Owned Business Enterprise (WBE) is defined as a business which is certified as being at least 51% owned, managed and controlled by one or more women.

- 3) A Disadvantaged Business (DBE) is defined as a business which is certified as being at least 51% owned, managed and controlled by a person(s) that are economically and socially disadvantaged.
- 4) A Veteran-Owned Small Business (VOSB) is defined as a business which is certified as being at least 51% owned, managed and controlled by a veteran and/or a service disabled veteran.
- 5) Good Faith Efforts are efforts that, given all relevant circumstances, a bidder or proposer actively and aggressively seeking to meet the goals, can reasonably be expected to make. In evaluating good faith efforts made toward achieving the goals, whether the bidder or proposer has performed the efforts outlined in the Obligations of Bidder for Good Faith Efforts outlined in this document will be considered, along with any other relevant factors.

D. OBLIGATION OF BIDDER FOR GOOD FAITH EFFORTS

- 1) **The bidder shall make a Good Faith Effort to achieve the Participation Goal for MWDBE and Veteran-Owned subcontractors/suppliers. The failure to meet the goal shall not necessarily be cause for disqualification of the bidder; however, bidders not meeting the goal are required to furnish with their bids written documentation of their Good Faith Efforts to do so.**
- 2) Award of Contract shall be conditioned upon satisfaction of the requirements set forth herein.
- 3) The Form of Proposal includes a section entitled "MWDBE Participation Form". The applicable information must be completed and submitted as outlined below.
- 4) **Failure to submit this information as requested may be cause for rejection of bid or delay in contract award.**

E. DOCUMENTATION REQUIRED FOR GOOD FAITH EFFORTS

- 1) Bidders reaching the Goal are required to submit only the MWDBE Participation Form." The form must be fully completed including names and telephone number of participating MWDBE firm(s); type of work to be performed; estimated value of the contract and value expressed as a percentage of the total Lump Sum Bid Price. The form must be signed and dated, and is to be submitted with the bid.
- 2) Bidders not reaching the Goal must submit the "MWDBE Participation Form", the "Quote Summary Form" and a written statement documenting their Good Faith Effort to do so. If bid includes no MWDBE and/or Veteran participation, bidder shall enter "None" on the subcontractor / supplier form). In addition, the bidder must submit written proof of their Good Faith Efforts to meet the Participation Goal:
 - a. Advertised opportunities to participate in the contract in at least two (2) publications of general circulation media; trade and professional association publications; small and minority business or trade publications; and publications or trades targeting minority, women and disadvantaged businesses not less than fifteen (15) days prior to the deadline for submission of bids to allow MWDBE firms and Veteran-Owned businesses to participate.
 - b. Included documentation of advertising in the above publications with the bidders good faith efforts package

- c. Attended LFUCG Central Purchasing Economic Inclusion Outreach event
- d. Attended pre-bid meetings that were scheduled by LFUCG to inform MWDBEs and/or Veteran-Owned businesses of subcontracting opportunities
- e. Sponsored Economic Inclusion event to provide networking opportunities for prime contractors and MWDBE firms and Veteran-Owned businesses.
- f. Requested a list of MWDBE and/or Veteran subcontractors or suppliers from LFUCG and showed evidence of contacting the companies on the list(s).
- g. Contacted organizations that work with MWDBE companies for assistance in finding certified MWDBE firms and Veteran-Owned businesses to work on this project. Those contacted and their responses should be a part of the bidder's good faith efforts documentation.
- h. Sent written notices, by certified mail, email or facsimile, to qualified, certified MWDBEs and/or Veteran-Owned businesses soliciting their participation in the contract not less than seven (7) days prior to the deadline for submission of bids to allow them to participate effectively.
- i. Followed up initial solicitations by contacting MWDBEs and Veteran-Owned Businesses to determine their level of interest.
- j. Provided the interested MWDBE firm and/or Veteran-Owned business with adequate and timely information about the plans, specifications, and requirements of the contract.
- k. Selected portions of the work to be performed by MWDBE firms and/or Veteran-Owned businesses in order to increase the likelihood of meeting the contract goals. This includes, where appropriate, breaking out contract work items into economically feasible units to facilitate MWDBE and Veteran participation, even when the prime contractor may otherwise perform these work items with its own workforce
- l. Negotiated in good faith with interested MWDBE firms and Veteran-Owned businesses not rejecting them as unqualified without sound reasons based on a thorough investigation of their capabilities. Any rejection should be so noted in writing with a description as to why an agreement could not be reached.
- m. Included documentation of quotations received from interested MWDBE firms and Veteran-Owned businesses which were not used due to uncompetitive pricing or were rejected as unacceptable and/or copies of responses from firms indicating that they would not be submitting a bid.
- n. Bidder has to submit sound reasons why the quotations were considered unacceptable. The fact that the bidder has the ability and/or desire to perform the contract work with its own forces will not be considered a sound reason for rejecting a MWDBE and/or Veteran-Owned business's quote. Nothing in this provision shall be construed to require the bidder to accept unreasonable quotes in order to satisfy MWDBE and Veteran goals.

o. Made an effort to offer assistance to or refer interested MWDBE firms and Veteran-Owned businesses to obtain the necessary equipment, supplies, materials, insurance and/or bonding to satisfy the work requirements of the bid proposal

p. Made efforts to expand the search for MWBE firms and Veteran-Owned businesses beyond the usual geographic boundaries.

q. Other--any other evidence that the bidder submits which may show that the bidder has made reasonable good faith efforts to include MWDBE and Veteran participation.

Note: Failure to submit any of the documentation requested in this section may be cause for rejection of bid. Bidders may include any other documentation deemed relevant to this requirement which is subject to review by the MBE Liaison. Documentation of Good Faith Efforts must be submitted with the Bid, if the participation Goal is not met.



LEXINGTON

MINORITY BUSINESS ENTERPRISE PROGRAM

Sherita Miller, MPA
Minority Business Enterprise Liaison
Division of Central Purchasing
Lexington-Fayette Urban County Government
200 East Main Street
Lexington, KY 40507
smiller@lexingtonky.gov
859-258-3323

OUR MISSION: The mission of the Minority Business Enterprise Program is to facilitate the full participation of minority and women owned businesses in the procurement process and to promote economic inclusion as a business imperative essential to the long term economic viability of Lexington-Fayette Urban County Government.

To that end the city council adopted and implemented Resolution 484-2017 – A Certified Minority, Women and Disadvantaged Business Enterprise ten percent (10%) minimum goal and a three (3%) minimum goal for Certified Veteran-Owned Small Businesses and Certified Service Disabled Veteran – Owned Businesses for government contracts.

The resolution states the following definitions shall be used for the purposes of reaching these goals (a full copy is available in Central Purchasing):

Certified Disadvantaged Business Enterprise (DBE) – a business in which at least fifty-one percent (51%) is owned, managed and controlled by a person(s) who is socially and economically disadvantaged as define by 49 CFR subpart 26.

Certified Minority Business Enterprise (MBE) – a business in which at least fifty-one percent (51%) is owned, managed and controlled by an ethnic minority (i.e. African American, Asian American/Pacific Islander, Hispanic Islander, Native American/Native Alaskan Indian) as defined in federal law or regulation as it may be amended from time-to-time.

Certified Women Business Enterprise (WBE) – a business in which at least fifty-one percent (51%) is owned, managed and controlled by a woman.

Certified Veteran-Owned Small Business (VOSB) – a business in which at least fifty-one percent (51%) is owned, managed and controlled by a veteran who served on active duty with the U.S. Army, Air Force, Navy, Marines or Coast Guard.

Certified Service Disabled Veteran Owned Small Business (SDVOSB) – a business in which at least fifty-one percent (51%) is owned, managed and controlled by a disabled veteran who served on active duty with the U.S. Army, Air Force, Navy, Marines or Coast Guard.

The term “Certified” shall mean the business is appropriately certified, licensed, verified, or validated by an organization or entity recognized by the Division of Purchasing as having the appropriate credentials to make a determination as to the status of the business.

We have compiled the list below to help you locate certified MBE, WBE and DBE certified businesses. Below is a listing of contacts for LFUCG Certified MWDBEs and Veteran-Owned Small Businesses in (<https://lexingtonky.ionwave.net>)

Business	Contact	Email Address	Phone
LFUCG	Sherita Miller	smiller@lexingtonky.gov	859-258-3323
Commerce Lexington – Minority Business Development	Tyrone Tyra	tyra@commercelexington.com	859-226-1625
Tri-State Minority Supplier Diversity Council	Susan Marston	smarston@tsmsdc.com	502-365-9762
Small Business Development Council	Shawn Rogers UK SBDC	shawn.rogers@uky.edu	859-257-7666
Community Ventures Corporation	Phyllis Alcorn	palcorn@cvky.org	859-231-0054
KY Transportation Cabinet (KYTC)	Melvin Byne	Melvin.bynes2@ky.gov	502-564-3601
KYTC Pre-Qualification	Shella Eagle	Shella.Eagle@ky.gov	502-782-4815
Ohio River Valley Women's Business Council (WBENC)	Sheila Mixon	smixon@orvwbc.org	513-487-6537
Kentucky MWBE Certification Program	Yvette Smith, Kentucky Finance Cabinet	Yvette.Smith@ky.gov	502-564-8099
National Women Business Owner's Council (NWBOC)	Janet Harris-Lange	janet@nwbo.org	800-675-5066
Small Business Administration	Robert Coffey	robertcoffey@sba.gov	502-582-5971
LaVoz de Kentucky	Andres Cruz	lavozdeky@yahoo.com	859-621-2106
The Key News Journal	Patrice Muhammad	production@keynewsjournal.com	859-685-8488



LFUCG MWDBE PARTICIPATION FORM
Bid/RFP/Quote Reference # 5-2018

The MWDBE and/or veteran subcontractors listed have agreed to participate on this Bid/RFP/Quote. If any substitution is made or the total value of the work is changed prior to or after the job is in progress, it is understood that those substitutions must be submitted to Central Purchasing for approval immediately. **Failure to submit a completed form may cause rejection of the bid.**

MWDBE Company, Name, Address, Phone, Email	MBE WBE or DBE	Work to be Performed	Total Dollar Value of the Work	% Value of Total Contract
1. VaOpto, LLC 5178 W. Patrick Ls Vegas, NV 89118 702-517-5789 scott@vaopto.com	MBE	Manufacturing		100%
2.				
3.				
4.				

The undersigned company representative submits the above list of MWDBE firms to be used in accomplishing the work contained in this Bid/RFP/Quote. Any misrepresentation may result in the termination of the contract and/or be subject to applicable Federal and State laws concerning false statements and false claims.

VaOpto, LLC

Company
2/9/2018

Date

Scott Hoag

Company Representative
Government Sales

Title



LEXINGTON

LFUCG MWDBE PARTICIPATION FORM

Bid/RFP/Quote Reference # 5-2018

The MWDBE and/or veteran subcontractors listed have agreed to participate on this Bid/RFP/Quote. If any substitution is made or the total value of the work is changed prior to or after the job is in progress, it is understood that those substitutions must be submitted to Central Purchasing for approval immediately. **Failure to submit a completed form may cause rejection of the bid.**

MWDBE Company, Name, Address, Phone, Email	MBE WBE or DBE	Work to be Performed	Total Dollar Value of the Work	% Value of Total Contract
1. VaOpto, LLC 5178 W. Patrick Las Vegas, NV 89118 702-517-5789 scott@vaopto.com	MBE	Manufacturing		100%
2.				
3.				
4.				

The undersigned company representative submits the above list of MWDBE firms to be used in accomplishing the work contained in this Bid/RFP/Quote. Any misrepresentation may result in the termination of the contract and/or be subject to applicable Federal and State laws concerning false statements and false claims.

VaOpto, LLC
 Company
2/9/2018
 Date

Scott Hoag
 Company Representative
Government Sales
 Title



LEXINGTON

LFUCG MWDBE SUBSTITUTION FORM

Bid/RFP/Quote Reference # 5-2018

The substituted MWDBE and/or veteran subcontractors listed below have agreed to participate on this Bid/RFP/Quote. These substitutions were made prior to or after the job was in progress. These substitutions were made for reasons stated below and are now being submitted to Central Purchasing for approval. By the authorized signature of a representative of our company, we understand that this information will be entered into our file for this project. **Failure to submit this form may cause rejection of the bid.**

SUBSTITUTED MWDBE Company Name, Address, Phone, Email	MWDBE Formally Contracted/ Name, Address, Phone, Email	Work to Be Performed	Reason for the Substitution	Total Dollar Value of the Work	% Value of Total Contract
1.	All work shall be preformed exclusively by VaOpto which is a 100% Minority Owned Business				
2.					
3.					
4.					

The undersigned acknowledges that any misrepresentation may result in termination of the contract and/or be subject to applicable Federal and State laws concerning false statements and false claims.

VaOpto, LLC
 Company
2/9/2018
 Date

Scott Hoag
 Company Representative
Government Sales
 Title



LEXINGTON

MWDBE QUOTE SUMMARY FORM

Bid/RFP/Quote Reference # 5-2018

The undersigned acknowledges that the minority and/or veteran subcontractors listed on this form did submit a quote to participate on this project. Failure to submit this form may cause rejection of the bid.

Company Name VaOpto, LLC		Contact Person Scott Hoag	
Address/Phone/Email 702-517-5789 Las Vegas, NV 89118 702-517-5789 scott@vaopto.com		Bid Package / Bid Date 5-2018 - February 14, 2018	

MWDBE Company Address	Contact Person	Contact Information (work phone, Email, cell)	Date Contacted	Services to be performed	Method of Communication (email, phone meeting, ad, event etc)	Total dollars \$\$ Do Not Leave Blank (Attach Documentation)	MBE * AA HA AS NA Female	Veteran
				All work shall be performed exclusively by VaOpto which is a 100% Minority Owned Business			AS	

(MBE designation / AA=African American / HA= Hispanic American/AS = Asian American/Pacific Islander/ NA= Native American)

The undersigned acknowledges that all information is accurate. Any misrepresentation may result in termination of the contract and/or be subject to applicable Federal and State laws concerning false statements and claims.

VaOpto, LLC
 Company
2/9/2018
 Date

Scott Hoag
 Company Representative
Government Sales
 Title



LEXINGTON

LFUCG SUBCONTRACTOR MONTHLY PAYMENT REPORT

The LFUCG has a 10% goal plan adopted by city council to increase the participation of minority and women owned businesses in the procurement process. The LFUCG also has a 3% goal plan adopted by cited council to increase the participation of veteran owned businesses in the procurement process. In order to measure that goal LFUCG will track spending with MWDBE and Veteran contractors on a monthly basis. By the signature below of an authorized company representative, you certify that the information is correct, and that each of the representations set forth below is true. Any misrepresentation may result in termination of the contract and/or prosecution under applicable Federal and State laws concerning false statements and false claims. Please submit this form monthly to the Division of Central Purchasing/ 200 East Main Street / Room 338 / Lexington, KY 40507.

Bid/RFP/Quote # 5-2018

Total Contract Amount Awarded to Prime Contractor for this Project Per Unit

Project Name/ Contract # <u>5-2018</u>	Work Period/ From: <u>Annual Contract</u> To:
Company Name: <u>VaOpto, LLC</u>	Address: <u>5178 W. Patrick, Las Vegas, NV 89118</u>
Federal Tax ID: <u>27-3892-739</u>	Contact Person: <u>Scott Hoag</u>

Subcontractor Vendor ID (name, address, phone, email)	Description of Work	Total Subcontract Amount	% of Total Contract Awarded to Prime for this Project	Total Amount Paid for this Period	Purchase Order number for subcontractor work (please attach PO)	Scheduled Project Start Date	Scheduled Project End Date
	All work shall be performed exclusively by VaOpto which is a 100% Minority Owned Business						

By the signature below of an authorized company representative, you certify that the information is correct, and that each of the representations set forth below is true. Any misrepresentations may result in the termination of the contract and/or prosecution under applicable Federal and State laws concerning false statements and false claims.

VaOpto, LLC
Company
2/9/2018
Date

Scott Hoag
Company Representative
Government Sales
Title

LFUCG STATEMENT OF GOOD FAITH EFFORTS

Bid/RFP/Quote # 5-2018

By the signature below of an authorized company representative, we certify that we have utilized the following Good Faith Efforts to obtain the maximum participation by MWDBE and Veteran-Owned business enterprises on the project and can supply the appropriate documentation.

_____ Advertised opportunities to participate in the contract in at least two (2) publications of general circulation media; trade and professional association publications; small and minority business or trade publications; and publications or trades targeting minority, women and disadvantaged businesses not less than fifteen (15) days prior to the deadline for submission of bids to allow MWDBE firms and Veteran-Owned businesses to participate.

_____ Included documentation of advertising in the above publications with the bidders good faith efforts package

_____ Attended LFUCG Central Purchasing Economic Inclusion Outreach event

_____ Attended pre-bid meetings that were scheduled by LFUCG to inform MWDBEs and/or Veteran-Owned Businesses of subcontracting opportunities

Sponsored Economic Inclusion event to provide networking opportunities for prime contractors and MWDBE firms and Veteran-Owned businesses

_____ Requested a list of MWDBE and/or Veteran subcontractors or suppliers from LFUCG and showed evidence of contacting the companies on the list(s).

_____ Contacted organizations that work with MWDBE companies for assistance in finding certified MWDBE firms and Veteran-Owned businesses to work on this project. Those contacted and their responses should be a part of the bidder's good faith efforts documentation.

_____ Sent written notices, by certified mail, email or facsimile, to qualified, certified MWDBEs soliciting their participation in the contract not less than seven (7) days prior to the deadline for submission of bids to allow them to participate effectively.

_____ Followed up initial solicitations by contacting MWDBEs and Veteran-Owned businesses to determine their level of interest.

_____ Provided the interested MWDBE firm and/or Veteran-Owned business with adequate and timely information about the plans, specifications, and requirements of the contract.

_____ Selected portions of the work to be performed by MWDBE firms and/or Veteran-Owned businesses in order to increase the likelihood of meeting the contract goals. This includes, where appropriate, breaking out contract work items into economically feasible units to facilitate MWDBE and Veteran participation, even when the prime contractor may otherwise perform these work items with its own workforce

_____ Negotiated in good faith with interested MWDBE firms and Veteran-Owned businesses not rejecting them as unqualified without sound reasons based on a thorough investigation of their capabilities. Any rejection should be so noted in writing with a description as to why an agreement could not be reached.

Included documentation of quotations received from interested MWDBE firms and Veteran-Owned businesses which were not used due to uncompetitive pricing or were rejected as unacceptable and/or copies of responses from firms indicating that they would not be submitting a bid.

_____ Bidder has to submit sound reasons why the quotations were considered unacceptable. The fact that the bidder has the ability and/or desire to perform the contract work with its own forces will not be considered a sound reason for rejecting a MWDBE and/or Veteran-Owned business's quote. Nothing in this provision shall be construed to require the bidder to accept unreasonable quotes in order to satisfy MWDBE and Veteran goals.

_____ Made an effort to offer assistance to or refer interested MWDBE firms and Veteran-Owned businesses to obtain the necessary equipment, supplies, materials, insurance and/or bonding to satisfy the work requirements of the bid proposal

_____ Made efforts to expand the search for MWBE firms and Veteran-Owned businesses beyond the usual geographic boundaries.

_____ Other--any other evidence that the bidder submits which may show that the bidder has made reasonable good faith efforts to include MWDBE and Veteran participation.

NOTE: Failure to submit any of the documentation requested in this section may be cause for rejection of bid. Bidders may include any other documentation deemed relevant to this requirement which is subject to approval by the MBE Liaison. Documentation of Good Faith Efforts must be submitted with the Bid, if the participation Goal is not met.

The undersigned acknowledges that all information is accurate. Any misrepresentations may result in termination of the contract and/or be subject to applicable Federal and State laws concerning false statements and claims.

VaOpto, LLC
Company
2/9/2018
Date

Scott Hoag
Company Representative
Government Sales
Title

THIS CERTIFIES THAT

VAOPTO LLC



* Nationally certified by the: **WESTERN REGIONAL MINORITY SUPPLIER DEVELOPMENT COUNCIL**

*NAICS Code(s): 334413; 335110; 335121; 335122; 335129

* Description of their product/services as defined by the North American Industry Classification System (NAICS)

10/31/2017

Issued Date

WR02534

Certificate Number

Louis Green



10/31/2018

Expiration Date

Cecil Plummer, President

By using your password (NMSDC issued only), authorized users may log into NMSDC Central to view the entire profile: <http://nmsdc.org>

Certify. Develop. Connect. Advocate.

* MBEs certified by an Affiliate of the National Minority Supplier Development Council, Inc.®

Lexington-Fayette Urban County Government

Bid Information

Bid Owner Ms. Conni Hayes Buyer
Email chayes@lexingtonky.gov
Phone (859) 2583326
Fax (859) 2583322

Bid Number Bid 5-2018
Title LED Lighting Fixtures
Bid Type Bid
Issue Date 01/24/2018
Close Date 2/13/2018 02:00:00 PM (ET)

Contact Information

Address 200 East Main Street
Lexington, KY 40507

Contact Conni Hayes
Department Central Purchasing
Building Government Center Building
Floor/Room Room 338
Telephone (859) 2583320
Fax (859) 2583322
Email chayes@lexingtonky.gov

Ship to Information

Address Various LFUCG Locations
Lexington, KY 40507

Contact Louls Weckerling
Department Division of Facilities
Building
Floor/Room
Telephone (859) 4252829
Fax (859) 3674940
Email

Supplier Information

Company Name VaOpto, LLC
Contact Name Scott Hoag
Address 5178 W. Patrick
Las Vegas, NV 89118

Telephone 702-517-5789
Fax 702-979-3582
Email scott@vaopto.com

Supplier Notes

All Products are manufactured by VaOpto, LLC

By submitting your response, you certify that you are authorized to represent and bind your company and that you agree to all bid terms and conditions as stated in the attached bid/RFP/RFQ/Quote/Auction documents.

Signature

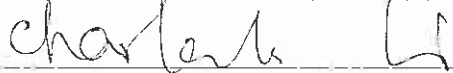

Date 2 / 9 / 2018

Bid Notes

All questions concerning this procurement must be submitted to buyer via email at chayes@lexingtonky.gov or preferably through the questions tab of this bid. Documents MUST be submitted on line prior to the close date and time.

Bid Activities

Bid Messages

Bid Attachments

The following attachments are associated with this opportunity and will need to be retrieved separately

#	Filename	Description
Header	Bid Documents.pdf	Bid documents. You can print these, fill them out and upload to "response attachments". No need to mail documents if completed documents are uploaded prior to bid end date.

Bid Attachments Requested

The following attachments are requested with this opportunity

Bid Attributes

Please review the following and respond where necessary

Line Items

#	Qty	UOM	Description	Response
1	1	EA	LED Round Flush Mount 11" Nom., 3000-4000K, CRI >= 80, > 1050LM, L70>= 50,000 hours, 120VAC, Poly or Acrylic Frosted Lens, Dimmable, , White Manufacturer: Topaz Manufacturer #: F-FM11/15/RN/P/30/WH 79004	\$ 39.00 (Optional) Unit Price
Item Notes: DLC QPL NOT REQUIRED				
Supplier Notes: Vaopto Product # VO-CL-1WW16V				
2	1	EA	LED Round Flush Mount 14" Nom., 3000-4000K, CRI >= 80, > 1550LM, L70>= 50,000 hours, 120VAC, Poly or Acrylic Frosted Lens, Dimmable, , White Manufacturer: Sylvania Manufacturer #: 74264 SURFACER1A/025120T840/14S/WH	\$ 40.00 (Optional) Unit Price
Item Notes: DLC QPL NOT REQUIRED				
Supplier Notes: VaOpto Product # VO-CL-1CW22V				
3	1	EA	LED STRIP LIGHT 24" 1600LM , 4000K, CRI >= 90, FROSTED LENS, 120-277 VAC, WHITE FINISH, FROSTED LENS Manufacturer: satco/nuvo Manufacturer #: 65/1081	\$ 28.00 (Optional) Unit Price
Item Notes: DLC QPL NOT REQUIRED				
Supplier Notes: VaOpto Product # VO-TF-04XX2-24-90				
4	1	EA	LED STRIP LIGHT 48" 3200LM , 4000K, CRI >= 90, FROSTED LENS, 120-277 VAC, WHITE FINISH, FROSTED LENS Manufacturer: satco/nuvo Manufacturer #: 65/1082	\$ 45.00 (Optional) Unit Price
Item Notes: DLC QPL NOT REQUIRED				
Supplier Notes: VaOpto Product # VO-TF-04XX4-24				
5	1	EA	LED STRIP LIGHT 24" 2000LM Nominal, 4000-5000K, CRI >= 80, FROSTED LENS, 120 VAC, WHITE FINISH, FROSTED LENS, DIMMABLE Manufacturer: Metalux Manufacturer #: 2SLSTP2040DD-120V UPC080083705788	\$ 27.00 (Optional) Unit Price
Supplier Notes: VaOpto Rproduct # VO-TF-04XX2-24				

6	1	EA	LED Floodlight 2 heads adjustable, 4000-5000K, CRI >= 75, >1000LM, 120vAC, with photocell	Manufacturer: Lithonia	Manufacturer #: OFLR 6P White or Bronze	\$ 38.00 (Optional) Unit Price
Item Notes: DLC QPL NOT REQUIRED						
Supplier Notes: VaOpto Product # VO-FD-NW-2						
7	1	EA	LED Candelabra Bulb(40w Equivilent), Round or Flame Tip, >= 300LM, E12 Base, 2700K-3000K, CRI >=70, L70 >=15000 hours	Manufacturer: open	Manufacturer #: Available from multiple manufacturers	\$ 2.50 (Optional) Unit Price
Item Notes: DLC QPL NOT REQUIRED						
Supplier Notes: VaOpto Product # VO-BULB-4WW						
8	1	EA	LED Candelabra Bulb(25w Equivilent), Round or Flame Tip, >= 200LM, E12 Base, 2700K-3000K, CRI >=70, L70 >=15000 hours	Manufacturer: open	Manufacturer #: Available from multiple manufacturers	\$ 2.40 (Optional) Unit Price
Item Notes: DLC QPL NOT REQUIRED						
Supplier Notes: VaOpto Product # VO-BULB-3WW						
9	1	EA	LED HID Replacement (150w Equivilent), Mogul - E39 Base, 4000-5000K, CRI >=80, L70>= 50,000 hours, 120-277VAC, >=130 LPW	Manufacturer: Eiko	Manufacturer #: LED27WPT40KMOG-G7	\$ 39.00 (Optional) Unit Price
Supplier Notes: VaOpto Product # VO-PT-27XNW-EyyR						
10	1	EA	LED HID Replacement (125w Equivilent), Mogul - E39 Base, 4000-5000K, CRI >=80, L70>= 50,000 hours, 120-277VAC, >=130 LPW	Manufacturer: Eiko	Manufacturer #: LED36WPT40KMOG-G7	\$ 43.00 (Optional) Unit Price
Supplier Notes: VaOpto Product # VO-PT-36XNW-Eyy						
11	1	EA	LED HID Replacement (175w Equivilent), Mogul - E39 Base, 4000-5000K, CRI >=80, L70>= 50,000 hours, 120-277VAC, >=130 LPW	Manufacturer: Eiko	Manufacturer #: LED45WPT40KMOG-G7	\$ 47.00 (Optional) Unit Price
Supplier Notes: VaOpto Product # VO-PT-45XNW-EyyR						

31 1 EA LED 2X4 DROP IN TROFFER, 4000K, 3900LM, 120-277 VAC, DIMMABLE,
 FLATPANEL, >=120 LPW, CRI >= 80, L70>= 50,000 hours
 Manufacturer: BAS Manufacturer #: FPEL24-40W-40K \$ 37.00
 (Optional)
 Unit Price

Supplier Notes: VaOpto Product # VO-PL-2XX4-50S-A

32 1 EA LED 2X4 DROP IN TROFFER, 4000K, 3900LM, 120-277 VAC, DIMMABLE,
 FLATPANEL, >=120 LPW, CRI >= 80, L70>= 50,000 hours, 90 Minute Battery Back-up
 Manufacturer: BAS Manufacturer #: FPEL24-40W-40K-EM \$ 75.00
 (Optional)
 Unit Price

Supplier Notes: VaOpto Product # VO-PL-2XX4-50S-A

33 1 EA LINEAR LED HIGH/LOW BAY FIXTURE, 4000 - 5000K, >=14,000 LM, CRI >=80, L70>=
 70,000 hours, 120-277VAC, >=130 LPW, FROSTED LENS, DIMMABLE
 Manufacturer: EIKO Manufacturer #: LLH-1C-50K-U \$ 100.00
 (Optional)
 Unit Price

Supplier Notes: VaOpto Product # VO-TF-1XDW2-110

34 1 EA LINEAR LED HIGH/LOW BAY FIXTURE, 4000 - 5000K, >=14,000 LM, CRI >=80, L70>=
 70,000 hours, 120-277VAC, >=130 LPW, FROSTED LENS, DIMMABLE, WITH
 OCCUPANCY SENSOR
 Manufacturer: EIKO Manufacturer #: LLH-1C-50K-U-1S \$ 110.00
 (Optional)
 Unit Price

Supplier Notes: VaOpto Product # VO-TF-1XDW2-110-S

35 1 EA LINEAR LED HIGH/LOW BAY FIXTURE, 4000 - 5000K, >=21,000 LM, CRI >=80, L70>=
 70,000 hours, 120-277VAC, >=130 LPW, FROSTED LENS, DIMMABLE
 Manufacturer: EIKO Manufacturer #: LLH-2C-50K-U \$ 141.00
 (Optional)
 Unit Price

Supplier Notes: VaOpto Product # VO-TF-1.5DW2-165

36 1 EA LINEAR LED HIGH/LOW BAY FIXTURE, 4000 - 5000K, >=21,000 LM, CRI >=80, L70>=
 70,000 hours, 120-277VAC, >=130 LPW, FROSTED LENS, DIMMABLE, WITH
 OCCUPANCY SENSOR
 Manufacturer: EIKO Manufacturer #: LLH-2C-50K-U-1S \$ 151.00
 (Optional)
 Unit Price

Supplier Notes: VaOpto Product # VO-TF-1.5DW2-165-S

37 1 EA LINEAR LED HIGH/LOW BAY FIXTURE, 4000 - 5000K, >=29,000 LM, CRI >=80, L70>=70,000 hours, 120-277VAC, >=130 LPW, FROSTED LENS, DIMMABLE
Manufacturer: EIKO Manufacturer #: LLH-3C-50K-U \$ 160.00
(Optional)
Unit Price

Supplier Notes: VaOpto Product # VO-TF-1DW4-225

38 1 EA LINEAR LED HIGH/LOW BAY FIXTURE, 4000 - 5000K, >=29,000 LM, CRI >=80, L70>=70,000 hours, 120-277VAC, >=130 LPW, FROSTED LENS, DIMMABLE, WITH OCCUPANCY SENSOR
Manufacturer: EIKO Manufacturer #: LLH-3C-50K-U-1S \$ 170.00
(Optional)
Unit Price

Supplier Notes: VaOpto Product # VO-TF-1DW4-225-S

VaOpto

LED Manufacturer

With world-class manufacturing facility since 1969 (30 million products manufactured daily, ISO14001/ISO9001/TS16949 certified, RoSH compliant, white LED licensed/patented), VAOPTO, an Energy Star SSL Partner, offers LEDs, LED assemblies, and LED light engines with USA quality, USA standard, custom service, and the competitive price.

Features: Single/RGB color, 2700k-8000k white, dimmable /non-dimmable GU5.3/GU10/
E26/E27 base, spotlight/floodlight/convex light, cross 20w/35w/50w Halogen MR16.
Certificates: USA/Canada Patent Pending, cULus File#E324837, CE

LED MR Lamp



MR11, GU5.3, 1W



MR16, GU10, 3W



MR16, GU5.3, 3W

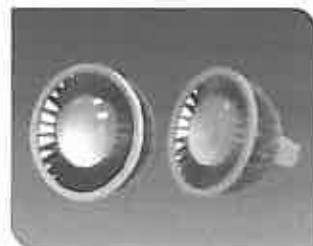

MR16, GU5.3 GU10, 7W

Features: Single/RGB color, 2700k-8000k white, dimmable/non-dimmable
30, 60, 90 and 120 degree beam spreads available
Certificates: USA/Canada Patent Pending, cULus File#E324837, CE

LED PAR Lamp



PAR16, E26, 3W



PAR20, E26, 5W



PAR30, E26, 7W

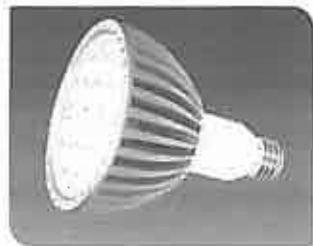

PAR38, E26, 18W

Features: Single/RGB color, 2700k-8000k white, dimmable/non-dimmable
Certificates: USA/Canada Patent Pending, International Patent, cULus File#E324837, CE

LED R-Lamp & Bulb



R20, E26, 5W



R30, E26, 7W



R40, E26, 18W



LED Bulb, E26, 7W

Vaopto(Headquater)

5178 West Patrick Lane
Las Vegas ,NV 89118

P: 702-517-5789

F: 702-979-3582

info@vaopto.com

www.vaopto.com

Vaopto (Canada)

7300 Victoria Park Ave, Unit F
Markham, ON, L3R 1J1 Canada

P: 905-707-5591

F: 905-707-6251

ychin@vaopto.com

www.vaopto.com

Distributors

www.americaii.com

www.e-sonic.com

www.marshellectronics.com

www.mixdeal.com.ar

www.nacsemi.com

www.pacrimeltec.com

www.wpgamericas.com

LED High Bay

Features: Green lighting, energy saving, long life

Certificates: USA/Canada Patent Pending, cULus File#E335469, CE



50W, 120-277VAC



100W, 120-277VAC



150W, 120-277VAC



LED Flood Light

Features: Green lighting, energy saving, long life

Certificates: USA/Canada Patent Pending, cULus File# E335469, CE



20W, 120-277VAC



50-200W, 120-277VAC



Linear Wallwasher

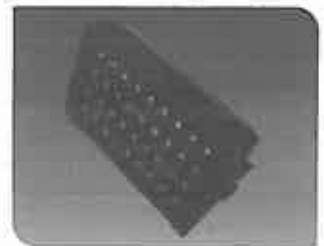

Square Wallwasher

LED Street Light

Features: Green lighting, energy saving, long life

Certificates: USA/Canada Patent Pending, cULus File# E335469, CE



50-200W, 120VAC

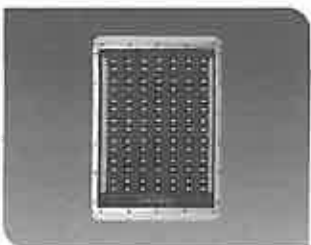

50-200W, 277VAC

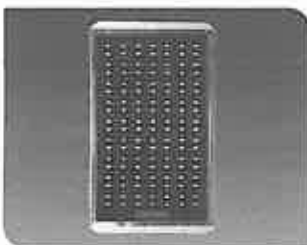

50-200W, 480VAC



Application



LED Down Light

Features: Single/RGB color, 2600k-8000k white, dimmable/non-dimmable
 Certificates: USA/Canada Patent Pending, cULus Pending, CE



2.5"/3"/4" 6" 8"
 class 2 driver



2.5"/3"/4" 6" 8"
 class 2 driver



6", E26, 15W



Puck light, 1.2" thickness,
 3W/lamp, class 2 driver

LED Reading Light

Features: Non-glaring, green light, long life, energy saving.
 Certificates: USA/Canada Patent, cULus File# E329183, CE

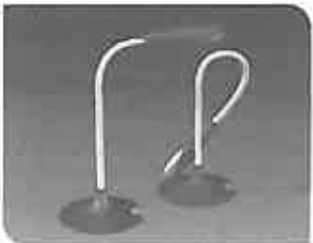

6W, class 2 driver



6W, class 2 driver



6W, class 2 driver



6W, class 2 driver

LED Panel Light

Features: Green lighting, energy saving, long life, dimmable/non-dimmable
 Certificates: USA/Canada Patent Pending, cULus Pending, CE

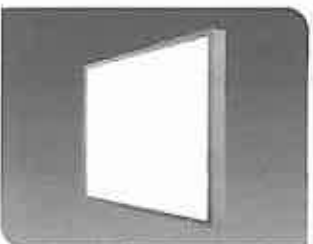

2ftx2ft, CW/NW/WW

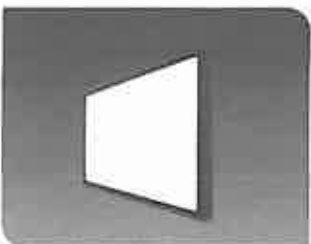

1ftx4ft, CW/NW/WW

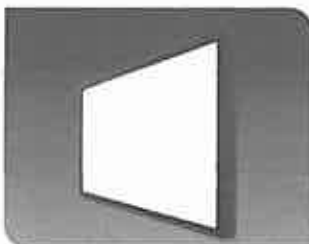

2ftx4ft, CW/NW/WW

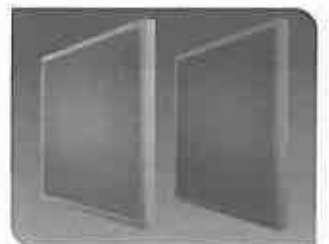

RGB

LED Ceiling Light

Ceiling Light

Product Description

VaOpto's LED Puck Light Series, which replaces traditional puck lights, is an energy-efficient, lead-free, UV-free, and long-lasting cold lighting source. In comparison to halogen puck lights, VaOpto's LED Puck Light Series reduces energy consumption by 50%-75%.

Product Information

Light color temperature available: 2800K~7000K.

- Cold white color is coded "CW"(5700-7000K)
 - Neutral white color is coded "NW"(4100-4800K)
 - Warm White color is coded "WW"(3000-3500K)
- Uses ultra-bright LEDs
 - Three-year limited warranty

Ordering Information

Part Number	Power (W)	Size (In)	Luminosity (LM)	Power Factor	CRI
VO-CL-1CW12V	12	Φ8.66*H3.35	900	>0.8	70
VO-CL-1NW12V	12	Φ8.66*H3.35	850	>0.8	70/ 80
VO-CL-1WW12V	12	Φ8.66*H3.35	800	>0.8	70/ 80
VO-CL-1CW16V	16	Φ11.02*H3.74	1200	>0.8	70
VO-CL-1NW16V	16	Φ11.02*H3.74	1140	>0.8	70/ 80
VO-CL-1WW16V	16	Φ11.02*H3.74	1090	>0.8	70/ 80
VO-CL-1CW22V	22	Φ12.6*H4.13	1500	>0.8	70
VO-CL-1NW22V	22	Φ12.6*H4.13	1425	>0.8	70/ 80
VO-CL-1WW22V	22	Φ12.6*H4.13	1350	>0.8	70/ 80

Energy Star Performance

- Lamps designed to produce at least 70% of Initial light output after 50,000 hours

Power

- Input Voltage: 100-120V AC

Certifications



Installation

For installation information please refer to the installation guide found on our website, www.vaopto.com.



VaOpto
LED Manufacturer

VAOPTO
5178 W. Patrick Lane
Las Vegas, NV 89118, U.S.A.
P: 702-517-5789 F: 702-979-3582
Info@vaopto.com
www.vaopto.com

VaOpto

LED Manufacturer

LED Troffers & LED Panel Lights

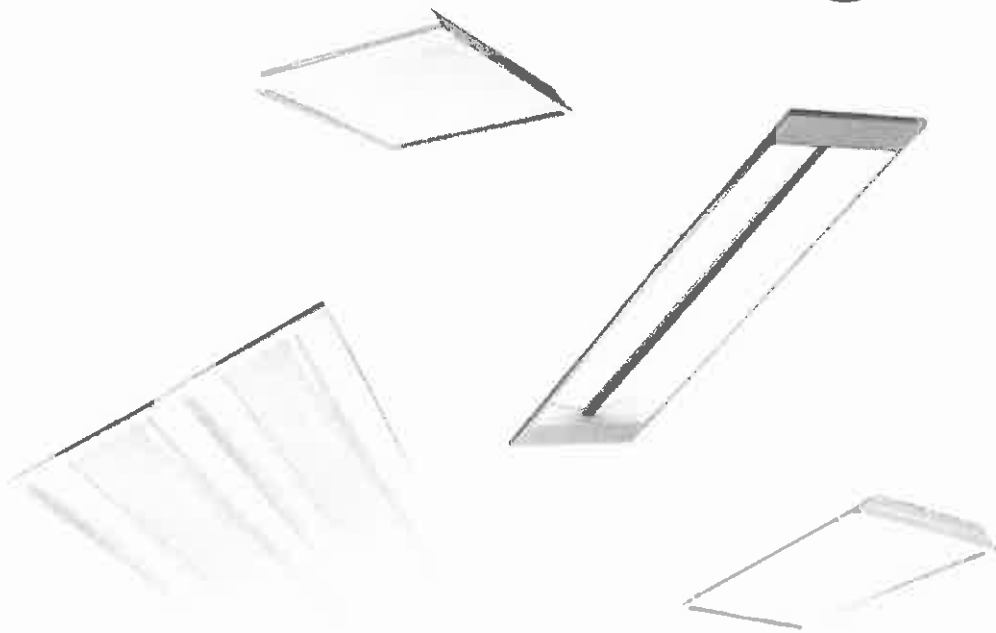

Product Guide



Decorative LED Troffers

LED Troffer Decorative Single

Part #	Size	Length	Height	Power Watt	LED
VO-TF-2CW2-524	2'X2'	2400	24	110 - 277 V AC	6500
VO-TF-2DW2-524	2'X2'	2300	24	110 - 277 V AC	5000
VO-TF-2NW2-524	2'X2'	2200	24	110 - 277 V AC	4000
VO-TF-2WW2-524	2'X2'	2100	24	110 - 277 V AC	3500
VO-TF-2CW2-536	2'X2'	3700	36	110 - 277 V AC	6500
VO-TF-2DW2-536	2'X2'	3500	36	110 - 277 V AC	5000
VO-TF-2NW2-536	2'X2'	3300	36	110 - 277 V AC	4000
VO-TF-2WW2-536	2'X2'	3100	36	110 - 277 V AC	3500
VO-TF-1CW4-524	1'X4'	2400	24	110 - 277 V AC	6500
VO-TF-1DW4-524	1'X4'	2300	24	110 - 277 V AC	5000
VO-TF-1NW4-524	1'X4'	2200	24	110 - 277 V AC	4000
VO-TF-1WW4-524	1'X4'	2100	24	110 - 277 V AC	3500
VO-TF-1CW4-536	1'X4'	3700	36	110 - 277 V AC	6500
VO-TF-1DW4-536	1'X4'	3500	36	110 - 277 V AC	5000
VO-TF-1NW4-536	1'X4'	3300	36	110 - 277 V AC	4000
VO-TF-1WW4-536	1'X4'	3100	36	110 - 277 V AC	3500
VO-TF-2CW4-542	2'X4'	4700	42	110 - 277 V AC	6500
VO-TF-2DW4-542	2'X4'	4500	42	110 - 277 V AC	5000
VO-TF-2NW4-542	2'X4'	4300	42	110 - 277 V AC	4000
VO-TF-2WW4-542	2'X4'	4100	42	110 - 277 V AC	3500
VO-TF-2CW4-568	2'X4'	7200	68	110 - 277 V AC	6500
VO-TF-2DW4-568	2'X4'	6800	68	110 - 277 V AC	5000
VO-TF-2NW4-568	2'X4'	6500	68	110 - 277 V AC	4000
VO-TF-2WW4-568	2'X4'	6200	68	110 - 277 V AC	3500

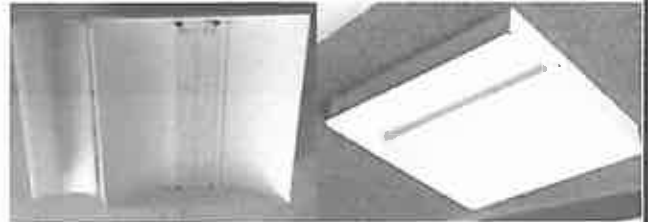

LED Troffer Decorative Duel

Part #	Size	Length	Height	Power Watt	LED
VO-TF-2CW2-D24	2'X2'	2400	24	110 - 277 V AC	6500
VO-TF-2DW2-D24	2'X2'	2250	24	110 - 277 V AC	5000
VO-TF-2NW2-D24	2'X2'	2100	24	110 - 277 V AC	4000
VO-TF-2WW2-D24	2'X2'	2000	24	110 - 277 V AC	3500
VO-TF-2CW2-D36	2'X2'	3700	36	110 - 277 V AC	6500
VO-TF-2DW2-D36	2'X2'	3500	36	110 - 277 V AC	5000
VO-TF-2NW2-D36	2'X2'	3300	36	110 - 277 V AC	4000
VO-TF-2WW2-D36	2'X2'	3100	36	110 - 277 V AC	3500
VO-TF-1CW4-D24	1'X4'	2400	24	110 - 277 V AC	6500
VO-TF-1DW4-D24	1'X4'	2250	24	110 - 277 V AC	5000
VO-TF-1NW4-D24	1'X4'	2100	24	110 - 277 V AC	4000
VO-TF-1WW4-D24	1'X4'	2000	24	110 - 277 V AC	3500
VO-TF-1CW4-D36	1'X4'	3700	36	110 - 277 V AC	6500
VO-TF-1DW4-D36	1'X4'	3500	36	110 - 277 V AC	5000
VO-TF-1NW4-D36	1'X4'	3300	36	110 - 277 V AC	4000
VO-TF-1WW4-D36	1'X4'	3100	36	110 - 277 V AC	3500
VO-TF-2CW4-D42	2'X4'	4700	42	110 - 277 V AC	6500
VO-TF-2DW4-D42	2'X4'	4500	42	110 - 277 V AC	5000
VO-TF-2NW4-D42	2'X4'	4300	42	110 - 277 V AC	4000
VO-TF-2WW4-D42	2'X4'	4100	42	110 - 277 V AC	3500
VO-TF-2CW4-D68	2'X4'	7200	68	110 - 277 V AC	6500
VO-TF-2DW4-D68	2'X4'	6800	68	110 - 277 V AC	5000
VO-TF-2NW4-D68	2'X4'	6500	68	110 - 277 V AC	4000
VO-TF-2WW4-D68	2'X4'	6200	68	110 - 277 V AC	3500

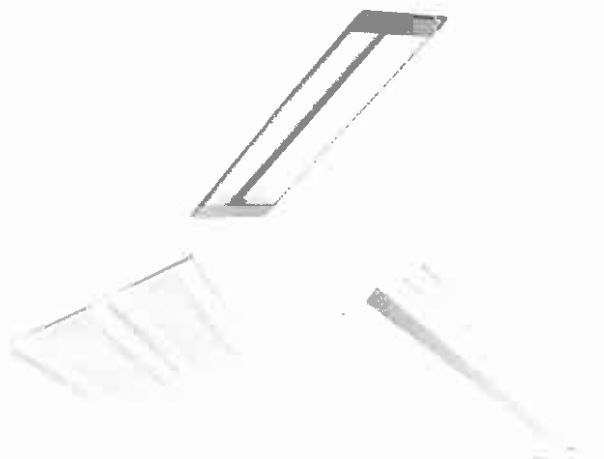
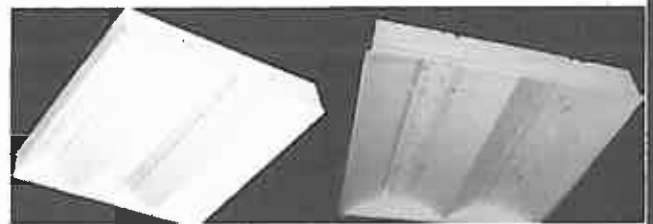

All VaOpto LED Troffers are dimmable.

LED Troffers



LED Outdoor Troffer

Part #	Size	Lumens	Wattage	Power Input	CCT
VO-TF-03NW2-12W	3"x2'	1100	12	110 - 277 V AC	4000
VO-TF-03NW4-24W	3"x4'	2100	24	110 - 277 V AC	4000
VO-TF-03NW5-40W	3"x5'	3600	40	110 - 277 V AC	4000
VO-TF-04NW2-12W	4"x2'	1100	12	110 - 277 V AC	4000
VO-TF-04NW2-24W	4"x2'	2100	24	110 - 277 V AC	4000
VO-TF-07NW2-24W	6.5"x2'	2100	24	110 - 277 V AC	4000
VO-TF-02NW4-24W	2.5"x4'	2100	24	110 - 277 V AC	4000
VO-TF-04NW4-24W	4"x4'	2100	24	110 - 277 V AC	4000
VO-TF-04NW4-48W	4"x4'	3900	48	110 - 277 V AC	4000
VO-TF-07NW4-48W	6.5"x4'	3900	48	110 - 277 V AC	4000
VO-TF-10NW4-72W	10"x4'	6000	72	110 - 277 V AC	4000
VO-TF-17NW4-96W	17"x4'	7000	72	110 - 277 V AC	4000
VO-TF-04NW5-40W	4"x5'	3600	40	110 - 277 V AC	4000
VO-TF-04NW5-80W	4"x5'	6500	80	110 - 277 V AC	4000
VO-TF-07NW5-80W	7"x5'	6500	80	110 - 277 V AC	4000
VO-TF-04NW6-48W	4"x6'	4000	48	110 - 277 V AC	4000
VO-TF-06NW2-24W	5.5"x2'	2100	24	110 - 277 V AC	4000
VO-TF-06NW4-48W	5.5"x4'	3900	48	110 - 277 V AC	4000
VO-TF-06NW5-80W	5.5"x5'	6500	80	110 - 277 V AC	4000
VO-TF-06NW6-96W	5.5"x6'	7000	96	110 - 277 V AC	4000
VO-TF-02NW4-96W	2.5"x4	2100	24	110 - 277 V AC	4000
VO-TF-07NW8-96W	6.5"x8'	7000	96	110 - 277 V AC	4000
VO-TF-18NW2-48W	17.5"x2	4000	48	110 - 277 V AC	4000



Available in 3500k WW, 5000k DW, and 6500k CW.
 Available with motion sensor, battery backup, and occupancy dimming function.

LED Linear High Bay

Part #	Size	Lumens	Wattage	Power Input	CCT
VO-TF-1NW4-104C	1'x4'	11303	104	110 - 277 V AC	4000
VO-TF-1NW4-104F	1'x4'	10727	104	110 - 277 V AC	4000
VO-TF-1NW4-136C	1'x4'	15375	136	110 - 277 V AC	4000
VO-TF-1NW4-136F	1'x4'	14606	136	110 - 277 V AC	4000
VO-TF-1NW4-208C	1'x4'	22395	208	110 - 277 V AC	4000
VO-TF-1NW4-208F	1'x4'	21275	208	110 - 277 V AC	4000
VO-TF-1.5NW4-104C	1.5'x4'	11303	104	110 - 277 V AC	4000
VO-TF-1.5NW4-104F	1.5'x4'	10727	104	110 - 277 V AC	4000
VO-TF-1.5NW4-136C	1.5'x4'	15375	136	110 - 277 V AC	4000
VO-TF-1.5NW4-136F	1.5'x4'	14606	136	110 - 277 V AC	4000
VO-TF-1.5NW4-208C	1.5'x4'	22395	208	110 - 277 V AC	4000
VO-TF-1.5NW4-208F	1.5'x4'	21275	208	110 - 277 V AC	4000



Available in 3500k WW, 5000k DW, and 6500k CW.

5178 West Patrick Lane, Las Vegas, NV 89118

Tel: (702)517-5789 . Fax:(702)979-3582 . Info@vaopto.com

www.vaopto.com

LED Troffers & Panel Lights

LED Troffer

Part #	Size	Lumens	Beams/ft	Power Input	CFR
VO-TF-2CW2-24	2'x2'	2300	24	110 - 277 V AC	6500
VO-TF-2DW2-24	2'x2'	2200	24	110 - 277 V AC	5000
VO-TF-2HW2-24	2'x2'	2100	24	110 - 277 V AC	4000
VO-TF-2WW2-24	2'x2'	2000	24	110 - 277 V AC	3500
VO-TF-2CW2-32	2'x2'	3400	32	110 - 277 V AC	6500
VO-TF-2DW2-32	2'x2'	3250	32	110 - 277 V AC	5000
VO-TF-2HW2-32	2'x2'	3100	32	110 - 277 V AC	4000
VO-TF-2WW2-32	2'x2'	2950	32	110 - 277 V AC	3500
VO-TF-2CW2-42	2'x2'	4400	42	110 - 277 V AC	6500
VO-TF-2DW2-42	2'x2'	4200	42	110 - 277 V AC	5000
VO-TF-2HW2-42	2'x2'	4000	42	110 - 277 V AC	4000
VO-TF-2WW2-42	2'x2'	3800	42	110 - 277 V AC	3500
VO-TF-1CW4-24	1'x4'	2400	24	110 - 277 V AC	6500
VO-TF-1DW4-24	1'x4'	2300	24	110 - 277 V AC	5000
VO-TF-1HW4-24	1'x4'	2200	24	110 - 277 V AC	4000
VO-TF-1WW4-24	1'x4'	2100	24	110 - 277 V AC	3500
VO-TF-2CW4-42	2'x4'	4700	42	110 - 277 V AC	6500
VO-TF-2DW4-42	2'x4'	4500	42	110 - 277 V AC	5000
VO-TF-2HW4-42	2'x4'	4300	42	110 - 277 V AC	4000
VO-TF-2WW4-42	2'x4'	4100	42	110 - 277 V AC	3500
VO-TF-2CW4-62	2'x4'	6700	62	110 - 277 V AC	6500
VO-TF-2DW4-62	2'x4'	6400	62	110 - 277 V AC	5000
VO-TF-2HW4-62	2'x4'	6100	62	110 - 277 V AC	4000
VO-TF-2WW4-62	2'x4'	5700	62	110 - 277 V AC	3500
VO-TF-2CW4-81	2'x4'	8900	81	110 - 277 V AC	6500
VO-TF-2DW4-81	2'x4'	8500	81	110 - 277 V AC	5000
VO-TF-2HW4-81	2'x4'	8100	81	110 - 277 V AC	4000
VO-TF-2WW4-81	2'x4'	7700	81	110 - 277 V AC	3500



LED Panel Light

Part #	Size	Lumens	Beams/ft	Power Input	CFR
VO-PL-1CW4-40	1'x4'	3300	40	110 - 277 V AC	6500
VO-PL-1DW4-40	1'x4'	3150	40	110 - 277 V AC	5000
VO-PL-1HW4-40	1'x4'	3000	40	110 - 277 V AC	4100
VO-PL-1WW4-40	1'x4'	2850	40	110 - 277 V AC	3500
VO-PL-2CW2-40	2'x2'	3300	40	110 - 277 V AC	6500
VO-PL-2DW2-40	2'x2'	3150	40	110 - 277 V AC	5000
VO-PL-2HW2-40	2'x2'	3000	40	110 - 277 V AC	4100
VO-PL-2WW2-40	2'x2'	2850	40	110 - 277 V AC	3500
VO-PL-2CW2-60	2'x2'	2850	60	110 - 277 V AC	6500
VO-PL-2DW2-60	2'x2'	4400	60	110 - 277 V AC	5000
VO-PL-2HW2-60	2'x2'	4200	60	110 - 277 V AC	4100
VO-PL-2WW2-60	2'x2'	4000	60	110 - 277 V AC	3500
VO-PL-2CW4-50	2'x4'	4400	50	110 - 277 V AC	6500
VO-PL-2DW4-50	2'x4'	4200	50	110 - 277 V AC	5000
VO-PL-2HW4-50	2'x4'	3750	50	110 - 277 V AC	4100
VO-PL-2WW4-50	2'x4'	3550	50	110 - 277 V AC	3500
VO-PL-2CW4-75	2'x4'	5750	75	110 - 277 V AC	6500
VO-PL-2DW4-75	2'x4'	5500	75	110 - 277 V AC	5000
VO-PL-2HW4-75	2'x4'	5250	75	110 - 277 V AC	4100
VO-PL-2WW4-75	2'x4'	5000	75	110 - 277 V AC	3500



All VaOpto LED Panel Lights are dimmable.

LED Flood Light

Flood Light

Product Description

VaOpto's LED Flood Light is an energy-efficient, lead-free, UV-free, and long-lasting cold lighting source. In comparison to standard high-pressure sodium flood lights, VaOpto's LED Flood Lights reduce energy consumption by 70%-80% and require fewer lamp replacements.

Product Information

- Cool White: CRI > 80
- Neutral White: CRI > 80
- Warm White: CRI > 80
- Uses ultra-bright LEDs
- Viewing angle: 60°

Ordering Information

Part Number	Dimensions(In)	Power (W)	Lumens (LM)	CCT
VO-FD-20CW1-60A-120N	12.6*11.02*10.63	24	1600	6500K
VO-FD-20NW1-60A-120N	12.6*11.02*10.63	24	1500	4100K
VO-FD-20WW1-60A-120N	12.6*11.02*10.63	24	1400	3500K



Part Number	Dimensions(In)	Power (W)	Lumens (LM)	CCT
VO-FD-CW-N42	10.63*11.81*6.52	42	3780	6500K
VO-FD-NW-N42	10.63*11.81*6.52	42	3570	4100K
VO-FD-WW-N42	10.63*11.81*6.52	42	3150	3500K
VO-FD-CW-N56	11.81*11.81*6.52	56	5040	6500K
VO-FD-NW-N56	11.81*11.81*6.52	56	4760	4100K
VO-FD-WW-N56	11.81*11.81*6.52	56	4200	3500K
VO-FD-CW-N70	13.03*11.81*6.52	70	6300	6500K
VO-FD-NW-N70	13.03*11.81*6.52	70	5950	4100K
VO-FD-WW-N70	13.03*11.81*6.52	70	5250	3500K
VO-FD-CW-N84	14.9*11.81*6.52	84	7560	6500K
VO-FD-NW-N84	14.9*11.81*6.52	84	7140	4100K
VO-FD-WW-N84	14.9*11.81*6.52	84	6720	3500K
VO-FD-CW-N98	16.75*11.81*6.52	98	8820	6500K
VO-FD-NW-N98	16.75*11.81*6.52	98	8330	4100K
VO-FD-WW-N98	16.75*11.81*6.52	98	7840	3500K

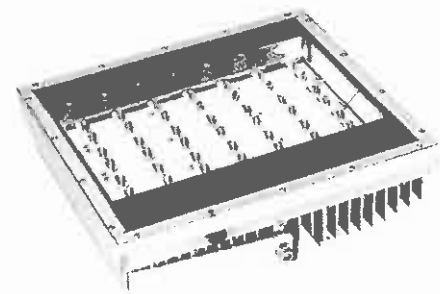

*42-LED count model shown

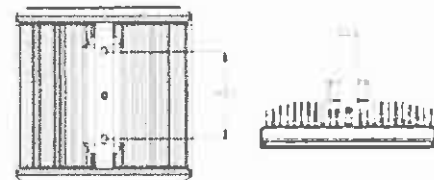
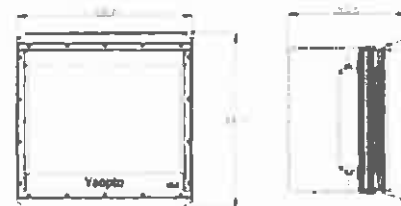

Energy Star Performance

- Lamps designed to produce at least 70% of initial light output after 50,000 hours

Power

- Input Voltage: 100-240V AC

Certifications

- cULus Listed File # E335469 Pending

Installation

For installation information please refer to the installation guide found on our website, www.vaopto.com.



VaOpto
LED Manufacturer

VAOPTO
5178 W. Patrick Lane
Las Vegas, NV 89118, U.S.A.
P: 702-517-5789 F: 702-979-3582
info@vaopto.com
www.vaopto.com

LED Array Vapor Fixture

Vapor Fixture

Product Description

VaOpto's LED Array Vapor Tight Fixture with LED driver and LED array replaces traditional vapor tight fixture and is an energy-efficient, lead-free, UV-free, and long-lasting cold lighting source. In comparison to fluorescent T8 tube lights, VAOPTO's LED Array Vapor Tight Fixture Series reduces energy consumption by 50%-75%.

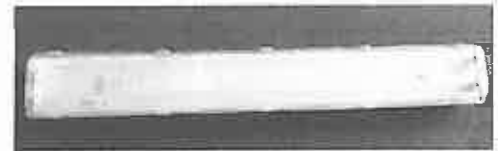

Product Information

- Power Input: 100-277VAC, 50/60Hz
- Beam Angle: 120°
- CRI: 90
- IP65
- 5-year limited warranty
- Weight: 8 lbs
- Lens and Base Material: PC
- Hasp: PC
- Hook material: Stainless Steel
- cULus: E335469 (Pending)

Ordering Information

Part Number	Wattage	Lumens	CCT
VO-TF-07W4-50CW90	50	5200	6500K
VO-TF-07W4-50DW90	50	5100	5000K
VO-TF-07W4-50NW90	50	5000	4100K
VO-TF-07W4-50WW90	50	5000	3500K

Safety Instruction

1. Electrical works have to be done by certified electrician.
2. In case of damages, disconnect the fixture from the power. Do not try to repair the fixture on your own. Repair has to be done by certified electrician.

L: 1270 mm (50 in)
 LF: 855 mm (34 in)
 W: 123 mm (5 in)
 H: 91 mm (3.5 in)



VAOPTO
 5178 W. Patrick Lane
 Las Vegas, NV 89118, U.S.A.
 P: 702-517-5789 F: 702-979-3582
 info@vaopto.com
 www.vaopto.com

LED Linear High Bay Light

Linear High Bay Light

Product Description

VaOpto's LED Linear High Bay Light Series, which replaces traditional Linear High Bay lights, is an energy-efficient, lead-free, UV-free, and long-lasting cold lighting source. In comparison to traditional Linear High Bay lights, VaOpto's LED Linear High Bay Series reduces energy consumption by 50%-75%.

Product Information

- Power Input: 100-277(347, 480)VAC
- CRI 80
- Efficiency: 130LM/W
- 0-10V Dimming to 10%
- Viewing Angle: 120°
- Operation Temperature: -40~135F
- Storage Temperature: -40~185F
- For Dry or Damp Location
- 5-year limited warranty
- Lifetime: 50,000 hours

Ordering Information

Part Number	Size (FT)	Lumens (LM)	Wattage (W)
VO-HBL-80XX2-120P277	1'x2'	10,400	80
VO-HBL-110XX2-120P277	1'x2'	14,300	110
VO-HBL-160XX2-120P277	1.5'x2'	20,800	160
VO-HBL-220XX4-120P277	1'x4'	28,600	220
VO-HBL-280XX4-120P277	1.5'x4'	36,400	280

XX for CCT:

XW(2700K), XWW(3000K), WW(3500K), NW(4000K), XDW(4500K), DW(5000K), XCW(5700K), CW(6500K), ETC.

Certifications

- cULus E335469 and DLC Premium rated

Installation Options

- Highbay Motion Sensor
- High Voltage Transformers
- Emergency Battery Back-up
- Frosted Lens
- Clear Lens
- Wire Guard Option
- Pendant Mount Option
- Surge Protector
- Safety Frame Option

For installation information please refer to the installation guide found on our website, www.vaopto.com.

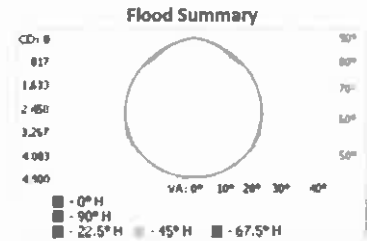
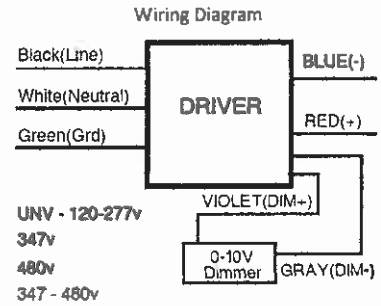

Illuminance at a Distance

Center Beam Lux	Beam Width
8.3M	69.75 LUX
16.7M	17.44 LUX
25.0M	7.75 LUX
33.3M	4.36 LUX
41.7M	2.79 LUX
50.0M	1.94 LUX

Vert. Spread: 112.3° Horiz. Spread: 113.1°

Zonal Lumen Summary

Zone	Lumens	% Luminaire
0-30	3,812.1	28.9%
0-40	6,292.8	47.7%
0-60	10,119.0	84.3%
60-90	1,058.4	15.6%
70-100	611.0	4.6%
90-120	8.0	0.1%
0-90	11,227.4	99.8%
90-180	20.1	0.2%
0-180	11,227.5	100%



VaOpto
LED Manufacturer

VAOPTO
5178 W. Patrick Lane
Las Vegas, NV 89118, U.S.A.
P: 702-517-5789 F: 702-979-3582
info@vaopto.com
www.vaopto.com