

LEXINGTON-FAYETTE URBAN COUNTY GOVERNMENT CONTRACT CHANGE ORDER Page 1 of 2	Date	June 29, 2016
	Project:	Senior Citizen Center Construction
	Location:	Lexington
To (Contractor): Marrillia Design & Construction 259 West Short Street Suite 325 Lexington, KY 40507	Contract No	227-2014
	Original Contract Amt	\$8,882,900.00
	Cumulative Amount of Previous Change Orders	\$1,524,073.37
	Percent Change - Previous Change Orders	17.16%
	Total Contract Amount Prior to this Change Order	\$10,406,973.37
	Change Order No	50

You are hereby requested to comply with the following changes from the contract plans and specification:

Current Change Order

Item No	Description of changes-quantities, unit prices, change in completion date, etc	Decrease in contract price	Increase in contract price
1	Furnish & install additional exit signage per PR 86		\$2,830.00
2	Furnish & install a closure door @ security grille per PR 91		\$320.00
	Total decrease	\$0.00	
	Total increase		\$3,150.00
	Net Amount of this Change Order	\$3,150.00	
	New Contract Amount Including this Change Order	\$10,410,123.37	
	Percent Change - This Change Order		0.04%
	Percent Change - All Change Orders		17.19%

The time provided for the completion in the contract and all provisions of the contract will apply hereto.

Recommended by <i>Jay...</i>	(Project Manager)	Date 6/29/16
Accepted by <i>Paul...</i>	(Contractor)	Date 6/29/16
Approved by <i>Paul...</i>	(Director)	Date 6-29-16
Approved by <i>[Signature]</i>	(Commissioner)	Date 6-29-16
Approved by <i>[Signature]</i>	(Mayor or CAO)	Date 6-29-16

JUSTIFICATION FOR CHANGE

PROJECT Senior Citizen Center Construction

CONTRACT NO. 227-2014

CHANGE ORDER NO. 50

1. Necessity for change: Fire Marshal requires 3 additional exit signs to be installed. A closure door is needed at the security grille at the reception desk to conceal the door when the grille is not being used.

2. Is proposed change an alternate bid? ___ Yes X No

3. Will proposed change alter the physical size of the project? ___ Yes X No
If "Yes", explain.

4. Effect of this change on other prime contractors: N/A

5. Has consent of surety been obtained? ___ Yes X Not Necessary

6. Will this change affect expiration or extent of insurance coverage? ___ Yes X No
If "Yes", will the policies be extended? ___ Yes ___ No

7. Effect on operation and maintenance costs:

8. Effect on contract completion date: 0 working days



Mayor

Date



Alternates
 UCC Replacement Senior Citizen Center
 Lexington, KY

01/20/2017
 10:49:02

Pending Owner Approval

PR-96 Furnish and Install Additional Exit Signage per Proposal Request No. 86 - Revision #1

Furnish and Install Additional Exit Signage per Proposal Request No. 86

Furnish and Install Additional Exit Signage per Proposal Request No. 86 - AES

Quantity	Units	Hr	Rate	Labor	Material (Sales Tax Added Below)	Subcontract	Total
	1	Is			2,435.00	2,435.00	
				0	0	2,435.00	2,435.00

Cost of In-Place Construction (Labor, Materials and Equipment)	2,435.00
Marrilla Design and Construction Overhead Percentage	10.00%
Overhead - Marrilla Design and Construction	243.50
Marrilla Design and Construction Profit Percentage	10.00%
Profit - Marrilla Design and Construction	243.50
General Liability Insurance (Construction)	1.00
Builder's Risk Insurance	1.00
Performance and Payment Bond (Rate of \$9.40 per \$1000 of Cost for \$0 - \$2,500,000)	22.82
Performance and Payment Bond (Rate of \$8.15 per \$1000 of Cost for \$2,500,000 - \$5,000,000)	19.88
Performance and Payment Bond (Rate of \$7.20 per \$1000 of Cost for \$5,000,000 and up)	17.40
KY Surcharge on Project Bonds (1.85% of Bond Cost)	3.52
Local Municipality Tax on Project Bonds (5% of Bond Cost)	6.96
Total Construction Cost	2,830.00



Proposal Request Transmittal

3000 North Loop West, Suite 1000, Houston, TX 77027

EOP Architects, 2314 West Loop South, Suite 1000, Houston, TX 77025

PROJECT	LFUCG Senior Citizens' Center 201333	DATE SENT	6/16/2016
SUBJECT	Additional Exit Signs	PROPOSAL REQUEST ID	PR-086
TYPE	Proposal Request	PROJECT NUMBER	00998
STATUS	For Review and Response	TYPE	Info Exchange

FROM:

NAME	ADDRESS	EMAIL	PHONE
Harding Dowell	EOP Architects	hdowell@ecpa.com	(859) 231-7538

TO:

NAME	ADDRESS	EMAIL	PHONE
Travis Harris	Marrillia Design and Construction	tharris@marrillia.com	

REMARKS:

Created by: Harding Dowell

Description:

Please provide pricing for three (3) additional exit signs per instruction from Building Inspection. The locations and types are as follows:

1. Add (1) exit sign at the southeast corner of the corridor in Administration 124. Refer to the attached sketch for circuiting, but confirm final location prior to installation. Exit sign shall be type X2 from the originally submitted lighting package.
2. Add (1) exit sign above door 150A. Exit sign shall be Iselite Series 850 (type BA (See attached cut sheet). Face color shall be green. Frame color shall be Brushed Aluminum. Service live shall be 20' clear. The sign shall be mounted on a ceiling bracket to the horizontal mullion.

Proposed Request for Submittal

6/16/2016

00998

- above the door frame (10'-4 1/4" AFF), such that the exit sign hangs below the mullion, centered on the door. Install per manufacturer's recommendations.
3. Add (1) exit sign above door 151C. Exit sign shall be Isolite Series 880-G-20-BA (see enclosed cut sheet). Face color shall be green. Frame color shall be Brushed Aluminum. Service life shall be 20 years. Install universal mounting bracket to the horizontal mullion above the door frame (10'-4 1/4" AFF), such that the exit sign hangs below the mullion, centered on the door. Install per manufacturer's recommendations.

The Isolite Series 880 shall not be purchased until owner and building inspector approval is given.

Thanks,

Harding

REVISION CONTROL

NO.	DATE	DESCRIPTION	BY	SCALE	SHEET	TOTAL
1	6/16/2016	160616_PR-086_SKE-17.pdf				
1	6/10/2016	illum exit sign 880 Series.pdf				

OTHER

Brian Gravitt	(Marrillia Design and Construction)
Jim Martin	(Marrillia Design and Construction)
Josh Marrillia	(Marrillia Design and Construction)
Rob Price	(Marrillia Design and Construction)
Jessica Walker	(LFUCG)
Joyce Thomas	(LFUCG)
Martin Woodford	(LFUCG)
Greg Brumagen	(CMTA)



ADVANCED ELECTRICAL SYSTEMS, INC.
 (502) 962-1102 Fax (502) 962-8836 www.aeslou.com

POWERING THE FUTURE!

PO Box 36503 Louisville, KY 40233-6503
 3312 Gilmore Industrial Bldg., Louisville, KY 40202

Change Order Summary

Time & Material Summary:
 Lump Sum: X

Description of work:

Install 3 additional exit signs per drawing

Activity Description	Material	Labor
X2 \$150 Each	\$ 150.00	\$ 1,276.00
Isolite Exit \$425 Each	\$ 850.00	\$ -
See attached	\$ 93.71	\$ -
	\$ -	\$ -
Subtotal Material & Labor	\$ 1,093.71	\$ 1,276.00

DEDUCT	Material	Labor
		\$0.00
Subtotal Deduct	\$0.00	\$0.00

Labor Rate Calculations				
Classification	HOURS	RATE	LABOR COST	
AGF ST	0	\$ 69.00	\$0.00	\$0.00
Gen. F-man ST	0	\$ 66.80	\$0.00	\$0.00
Foreman ST	20	\$ 63.80	\$1,276.00	\$1,276.00
Journeyman ST	0	\$ 59.25	\$0.00	\$0.00
Apprentice ST	0	\$ 43.80	\$0.00	\$0.00
AGF TH	0	\$ 94.00	\$0.00	\$0.00
Gen. F-man TH	0	\$ 90.25	\$0.00	\$0.00
Foreman TH	0	\$ 97.50	\$0.00	\$0.00
Journeyman TH	0	\$ 80.75	\$0.00	\$0.00
Apprentice TH	0	\$ 62.50	\$0.00	\$0.00
AGF DT	0	\$ 119.75	\$0.00	\$0.00
Gen. F-man DT	0	\$ 115.75	\$0.00	\$0.00
Foreman DT	0	\$ 111.25	\$0.00	\$0.00
Journeyman DT	0	\$ 102.50	\$0.00	\$0.00
Apprentice DT	0	\$ 77.75	\$0.00	\$0.00
Safety	0	\$ 85.00	\$0.00	\$0.00
Other	0		\$0.00	\$0.00
Subtotal Labor	20		\$1,276.00	\$1,276.00

Subcontractors	
	\$ -
Subtotal Subcontractors	\$ -

Equipment Rental (including tax)	
	\$ -
Subtotal Equipment Rental	\$ -

CUSTOMER ACCEPTANCE & AUTHORIZATION TO PROCEED WITH
 CHANGE ORDER :

AES Change Order No.	25
Contractor	Advanced Electrical Systems, Inc.
Date	June 27, 2016
Revision	1
AES Job No.	12200
Cust. Contract No.	
Cust. RFP No.	086
Additional Days	3
SWO #	
Classification:	Price Valid for 30 Days

BID SUMMARY

Material Cost	\$ 1,093.71
Material Mark-up 0.0%	\$ -
Subtotal	\$ 1,093.71
Tax 6%	\$ 65.62
Total Material Costs	\$ 1,159.33

Sub Contractor Costs	\$ -
Sub Contractor Mark-up 10.0%	\$ -
Total Sub Contractor Cost	\$ -

Equipment Rental	\$ -
Equipment Rental Mark up 0%	\$ -
Total Equipment Cost	\$ -

Labor Cost	\$ 1,276.00
Markup on Labor	\$ -
Total Labor Cost	\$ 1,276.00

Subtotal Add Cost	\$ 2,435.33
No Bond	\$ -
Total CO Add Cost	\$ 2,435.33

Material Deduct	\$ -
Tax on Deduct Material 0.0%	\$ -
Labor Deduct	\$ -
Subcontractor Deduct	\$ -
Equipment Rental Deduct	\$ -
Deduct Subtotal	\$ -
No Bond	\$ -
Total CO Deduct Cost	\$ -

Change Order Total:	\$ 2,435.33
----------------------------	--------------------

12 THHN CU STRANDED	283.5	\$102.90	M	1000	\$29.17	9 M	1000	2.55
14/2 NM-B ROMEX W/GHD CABLE	3	\$230.23	M	1000	\$0.69	45 M	1000	0.14
ROMEX CONNECTOR 3/8" 2 SCREW	3	\$46.94	C	0100	\$1.41	0.15 E	0001	0.45
1 ROMEX STAPLE	3	\$21.50	M	1000	\$0.06	0 X	0000	0
3/4 EMT	90	\$37.43	C	0100	\$33.69	7.5 C	0100	6.75
3/4 EMT CONN D/S	9	\$82.25	C	0100	\$7.40	0.15 E	0001	1.35
3/4 EMT COUP D/S	9	\$86.78	C	0100	\$7.81	0.07 F	0001	0.63
3/4 EMT 1 HOLE STP/STL	11.25	\$36.17	C	0100	\$4.07	6 C	0100	0.68
10 X 1-1/2 COMB PAN HD TAP SCR	11.25	\$3.38	C	0100	\$0.38	9 C	0100	1.01
1/4 FLAT STEEL WASHER	11.25	\$72.90	C	0100	\$8.20	1.09 C	0100	0.12
Tan 3M WIRE NUT	6	\$8.42	C	0100	\$0.50	0 C	0100	0
BUCHANAN 20065 4 #12 CU CRIMP CONN	3	\$10.70	C	0100	\$0.32	0 C	0100	0
REC. CAN 4" SMALL INC.	3	\$0.00	Q	0000	\$0.00	1.95 E	0001	5.85
					593.70			19.53

SERIES 2040-01/07 ALUMINUM FRAME

isolite



SELF-LUMINOUS EXIT SIGN

- Requires no electricity or external light source
- Maintenance free – no lamps or batteries to replace
- Easy to install – no wiring required
- Ideal for damp, wet and explosion proof applications
- Ideal for extreme temperatures (-67F to 176F)
- Service life – 10 or 20 years



ISOLITE SERIES 2040-01/07

Dimensions: 2040-01 Single Face

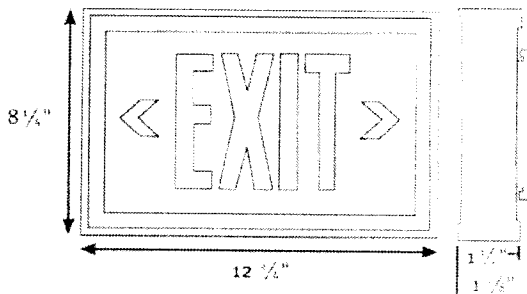

Dimensions: 2040-07 Double Face

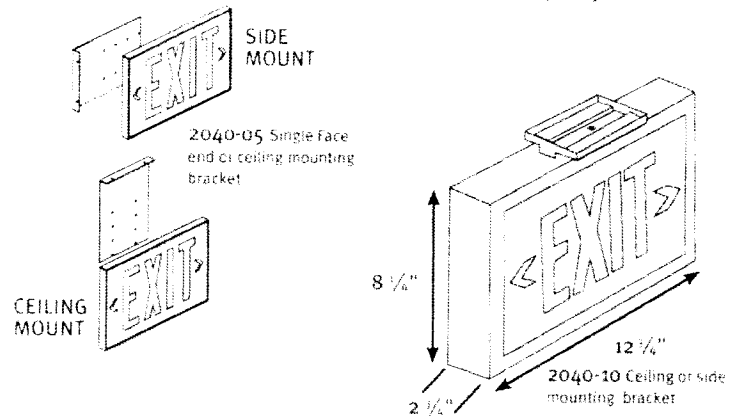

Specifications

- Overall Size:** Single Face: 12 3/4" x 8 1/4" x 1 1/2"
Double Face: 12 3/4" x 8 1/4" x 2 1/4"
- Weight:** Single Face: 4 lbs.
Double Face: 8 lbs.
- Frame:** Extruded aluminum
- Stencil:** Aluminum stencil
- Letters:** 6" high; 3/4" stroke, standard exit sign
- Arrows:** Universal chevrons
- Service Life:** 10 or 20 years
- Approvals:** UL Listed to UL 924 Standard, NFPA Life Safety Code 101

A continuous non-electrical source of illumination

Isolite Self-Luminous Signs are the practical solution for EXIT and safety marking requirements where performance cannot be compromised. These signs are totally self-contained, highly durable and attractive. The Isolite Self-Luminous Signs are illuminated with a light source that consists of glass tubes internally coated with phosphor and filled with tritium gas, a natural isotope of hydrogen. They are completely free of any external energy source providing 10-20 years of continuously illuminated, maintenance-free operation and code compliance.

- Features:**
- Special wording and pictograms available
 - Tamper-proof design
 - Double face sign utilizes one-piece construction frame
 - Custom colors available
- Warranty:** Our self-luminous products are warranted against any defects in material or workmanship for the rated life of the product.

Ordering Information

Model	Face Color	Service Life	Frame Color	Mounting Brackets	Options
2040-01 Single Face	R = Red G = Green BK = Black	10 = 10 Years 20 = 20 Years	BA = Brushed Aluminum (Standard) BK = Black WH = White	Surface Mount Standard 2040-05 = Single face (ceiling or end)	CW = Custom Wording LX = Lexan Stencil Cover
2040-07 Double Face	BZ = Bronze CC = Custom Color		BZ = Bronze CC = Custom Color	2040-10 = Double face (ceiling or end) PA = 12" Swivel Pendant PB = 24" Swivel Pendant PC = 36" Swivel Pendant PD = 48" Swivel Pendant	

Example: 2040-01-R to BK

Name _____
 Title _____
 Catalog Number _____
 Company _____
 Street _____
 City _____ State _____ Zip _____

isolite

at the Isolite office nearest you.

HEADQUARTERS
 11 Warrick Avenue
 Dover, NJ 07801
 (908) 751-1000
 (908) 751-1001
 (908) 751-1002

WESTERN OFFICE
 1505 Serrano, Suite M
 San Jose, CA 95128
 (415) 277-1045
 (415) 277-1046
 (415) 277-1047



Alternates
 LFUGG Replacement Senior Citizen Center
 Lexington, KY

6/28/2016
 4:42 PM

Waiting Owner Approval

PR-99 Furnish and Install a Closure Door at the Security Grille at the Reception Desk per Proposal Request No. 91

Furnish and Install a Closure Door at the Security Grille at the Reception Desk per Proposal Request No. 91

Furnish and Install a Closure Door at the Security Grille at the Reception Desk - U.S. Millwork

Quantity	Units	Hr	Rate	Labor	Mat	Materials (Sales Tax Added Below)	Subcontractor	Total
	1	Is				275.00	275	
				0		0	275	275

Cost of In-Place Construction (Labor, Materials and Equipment) =	275
Marrilia Design and Construction Overhead Percentage =	97.00
Overhead - Marrilia Design and Construction =	267
Marrilia Design and Construction Profit Percentage =	5.00
Profit - Marrilia Design and Construction =	14
General Liability Insurance (Construction) =	0
Builder's Risk Insurance =	0
Performance and Payment Bond (Rate of \$9.40 per \$1000 of Cost for \$0 - \$2,500,000) =	2.55
Performance and Payment Bond (Rate of \$8.15 per \$1000 of Cost for \$2,500,000 - \$5,000,000) =	2.25
Performance and Payment Bond (Rate of \$7.20 per \$1000 of Cost for \$5,000,000 and up) =	1.80
KY Surcharge on Project Bonds (1.8% of Bond Cost) =	0.33
Local Municipality Tax on Project Bonds (5.4% of Bond Cost) =	0.99
Total Construction Cost =	320



Proposal Request Transmittal

DATE: 6/22/2016 10:00 AM

EOP Address: 231 W. 5th St., Suite 200, Fort Collins, CO 80501-1001

PROJECT:	LFUCG Senior Citizens' Center 201333	DATE SENT:	6/22/2016
SUBJECT:	Security Grille Closure Door	PROJECT NUMBER:	PR-091
TYPE:	Proposal Request	PROJECT CODE:	01005
STATUS:	For Review and Response	STATUS:	Info Exchange

FROM:

NAME	COMPANY	EMAIL	PHONE
Harding Dowell	EOP Architects	hdowell@eopa.com	(859) 231-7538

TO:

NAME	COMPANY	EMAIL	PHONE
Travis Harris	Marrillia Design and Construction	tharris@marrillia.com	

REMARKS:

Created by: Harding Dowell

Description:

Please provide pricing to furnish and install a closure door at the face of the pocket that stores the sideways-rolling security grille at the Reception desk. The door shall be approx. 3'4" agnifiber board with white melamine facing on all faces and edges. The door shall be provided with a continuous piano hinge on the south edge (such that the door swings to the south); the hinge shall be a brushed chrome finish. The door shall be fitted with a magnetic catch - push release, push-to-secure hardware, with no exposed fasteners or hardware. Installation shall be coordinated with grille door and counter installation. See plan. All measurements prior to fabrication.

Proposal Request Transmittal

6/22/2016

15 01005

Thanks,

Harding

cc: :

Brian Gravitt	(Marrillia Design and Construction)
Jim Martin	(Marrillia Design and Construction)
Josh Marrillia	(Marrillia Design and Construction)
Rob Price	(Marrillia Design and Construction)
Jessica Walker	(LFUCG)
Joyce Thomas	(LFUCG)
Martin Woodford	(LFUCG)

Travis Harris

From: Dennis Wetzel <dennis@usmillwork.com>
Sent: Monday, June 27, 2016 3:45 PM
To: Travis Harris
Cc: Jim Martin
Subject: RE: Transmittal_ProposalRequest - PR-091 (Sent and Closed).pdf

U.S. MILLWORK, INC.

CASEWORK FOR COMMERCIAL APPLICATIONS

Response to Proposal Request 091

From: US Millwork, Inc
D. Wetzel
4815 Allmond Ave.
Louisville, KY 40214

To: TRAVIS HARRIS - MARRILLIA
LEXINGTON SENIOR CENTER
195 LIFE LANE
LEXINGTON, KY 40502

Date: 27 June 2016

We are sending you the following response to PR 091:

No	Question	Answer
1	Quote requested for closure door at rolling security grille at Reception area.	\$275.00 However, rolling security grille does not seem to fit so well into pocket. Lots of damage to GWB edges probable with daily use of grille. USMill suggests revisit of closure door design with possible wood or metal trim around face of opening, which this quote does not reflect.

- For review and comment

Dennis Wetzel

Project Manager
US Millwork, Inc
4815 Allmond Ave
Louisville, KY 40214
502) 587-9450

From: Travis Harris (mailto:tharris@usmillwork.com)
Sent: Thursday, June 23, 2016 9:11 AM
To: Dennis Wetzel

Cc: Jim Martin; Brian Gravitt

Subject: Transmittal_ProposalRequest - PR-091 (Sent and Closed).pdf

Dennis,

Please see the attached PR requesting pricing on the door to hide the grill door at the receptionist desk. You will need to field measure this after Bennetts fixes the drywall so the grill door is not rubbing the GWB.

Thanks,

Travis Harris

Site Manager

Marrillia Design and Construction

259 West Short Street, Suite 325

Lexington, Kentucky 40507

Tel 859.685.0414

Fax 859.685.0418

Cell 859.200.9732

Web www.marrillia.com

Email tharris@marrillia.com



[Submit Spam](#)

Travis Harris

From: Dennis Wetzel <dennis@usmillwork.com>
Sent: Monday, June 27, 2016 3:45 PM
To: Travis Harris
Cc: Jim Martin
Subject: RE: Transmittal_ProposalRequest - PR-091 (Sent and Closed).pdf

U.S. MILLWORK, INC.
CASEWORK FOR COMMERCIAL APPLICATIONS

Response to Proposal Request 091

From: US Millwork, Inc.
D. Wetzel
4815 Allmond Ave.
Louisville, KY 40214

To: TRAVIS HARRIS - MARRILLIA
LEXINGTON SENIOR CENTER
195 LIFE LANE
LEXINGTON, KY 40502

Date: 27 June 2016

We are sending you the following response to PR 091.

No	Question	Answer
1	Quote requested for closure door at rolling security grille at Reception area.	\$275.00 However, rolling security grille does not seem to fit so well into pocket. Lots of damage to GWB edges probable with daily use of grille. USMill suggests revisit of closure door design with possible wood or metal trim around face of opening, which this quote does not reflect.

- For review and comment.

Dennis Wetzel
Project Manager
US Millwork, Inc.
4815 Allmond Ave.
Louisville, KY 40214
502-587-9450

From: Travis Harris (mailto:tharris@manille.com)
Sent: Thursday, June 23, 2016 9:21 AM
To: Dennis Wetzel

Cc: Jim Martin; Brian Gravitt

Subject: Transmittal_ProposalRequest - PR-091 (Sent and Closed).pdf

Dennis,

Please see the attached PR requesting pricing on the door to hide the grill door at the receptionist desk. You will need to field measure this after Bennetts fixes the drywall so the grill door is not rubbing the GWB.

Thanks,

Travis Harris

Site Manager

Marrillia Design and Construction

259 West Short Street, Suite 325

Lexington, Kentucky 40507

Tel 859.685.0414

Fax 859.685.0418

Cell 859.200.9732

Web www.marrillia.com

Email tharris@marrillia.com



[Robert Storm](#)