

STRINGFELLOW

INC.

TRUCK BODIES • REFUSE EQUIPMENT • STREET SWEEPERS • SEWER CLEANERS
PARTS & SERVICE

April 13, 2017

Division of Central Purchasing
200 East Main St.
Lexington, KY 40507

Re: Bid #52-2017 Hooklift Loader Body

To all concerned:

Thank you for giving us this opportunity to submit the attached bid for a Swaploader SL - 650 Hooklift Loader Body to be mounted on your Kenworth T800 chassis.

We are pleased to submit a bid on a Swaploader SL 650 (Fixed 61 34" Jib) 65,000lb Dump/Lift Capacity (400 Series/65,000lb) with a Pioneer RP4500 SARG Tarp System. Our price for this unit is **\$48,298.00** each mounted on your chassis. Proposed delivery date is 60 – 90 days upon receipt of your chassis. All Bid Specifications have been considered and met with this bid.

Again, thank you for this opportunity. If we can be of service, please don't hesitate to contact us at (502) 773-1350.

Sincerely,

Mark A. Dodds
Kentucky Environmental Sales



Lexington-Fayette Urban County Government

Lexington, Kentucky
Horse Capital of the World

Division of Central Purchasing

Date of Issue: March 30, 2017

INVITATION TO BID #52-2017 Hooklift Loader Body

Bid Opening Date: April 13, 2017 **Bid Opening Time:** 2:00 PM
Address: 200 East Main Street, 3rd Floor, Room 338, Lexington, Kentucky 40507
Type of Bid: Price Contract

Pre Bid Meeting: N/A **Pre Bid Time:** N/A
Address: N/A

Sealed bids will be received in the office of the Division of Central Purchasing, 200 East Main Street, Lexington, Kentucky, until **2:00 PM**, prevailing local time on **4/13/2017**. Bids must be received by the above-mentioned date and time. Mailed bids should be sent to:

**Division of Central Purchasing
200 East Main Street, Room 338
Lexington, KY 40507, (859) 258-3320**

The Lexington-Fayette Urban County Government assumes no responsibility for bids that are not addressed and delivered as indicated above. **Bids that are not delivered to the Division of Central Purchasing by the stated time and date will be rejected.** All bids must be signed and have the company name and address, bid invitation number, and the name of the bid on the outside of the envelope.

Bids are to include all shipping costs to the point of delivery located at: 669 Byrd Thurman Drive

Bid Security Required: ___ Yes No *Cashier Check, Certified Check, Bid Bond (Personal checks and company checks will not be acceptable).*

Performance Bond Required: ___ Yes No

<input checked="" type="checkbox"/> Bid Specifications Met	Check One: ___ Exceptions to Bid Specifications. <i>Exceptions shall be itemized and attached to bid proposal submitted.</i>	Proposed Delivery: 60-90 days after acceptance of bid.
Procurement Card Usage —The Lexington-Fayette Urban County Government may be using Procurement Cards to purchase goods and services and also to make payments. Will you accept Procurement Cards? <input checked="" type="checkbox"/> Yes <input type="checkbox"/> No		

Submitted by:

Stringfellow, Inc
Firm Name

9053 Fern Creek Rd.
Address

Louisville, Ky 40291
City, State & Zip

Bid must be signed:
(original signature)

Mark Dodds
Signature of Authorized Company Representative – Title

MARK Dodds
Representative's Name (Typed or printed)

(502) 773-1250 / (502) 290-3840
Area Code - Phone - Extension Fax #

mark@stringfellow.biz
E-Mail Address

The Affidavit in this bid must be completed before your firm can be considered for award of this contract.

AFFIDAVIT

Comes the Affiant, JUDY B ANDERSON, and after being first duly sworn under penalty of perjury as follows:

1. His/her name is MARK DODDS and he/she is the individual submitting the bid or is the authorized representative of Stringfellow, Inc. the entity submitting the bid (hereinafter referred to as "Bidder")
2. Bidder will pay all taxes and fees, which are owed to the Lexington-Fayette Urban County Government at the time the bid is submitted, prior to award of the contract and will maintain a "current" status in regard to those taxes and fees during the life of the contract.
3. Bidder will obtain a Lexington-Fayette Urban County Government business license, if applicable, prior to award of the contract.
4. Bidder has authorized the Division of Central Purchasing to verify the above-mentioned information with the Division of Revenue and to disclose to the Urban County Council that taxes and/or fees are delinquent or that a business license has not been obtained.
5. Bidder has not knowingly violated any provision of the campaign finance laws of the Commonwealth of Kentucky within the past five (5) years and the award of a contract to the Bidder will not violate any provision of the campaign finance laws of the Commonwealth.
6. Bidder has not knowingly violated any provision of Chapter 25 of the Lexington-Fayette Urban County Government Code of Ordinances, known as "Ethics Act."
7. Bidder acknowledges that "knowingly" for purposes of this Affidavit means, with respect to conduct or to circumstances described by a statute or ordinance defining an offense, that a person is aware or should have been aware that his conduct is of that nature or that the circumstance exists.

Further, Affiant sayeth naught. _____

STATE OF Tennessee

COUNTY OF Robertson

The foregoing Instrument was subscribed, sworn to and acknowledged before me by MARK DODDS / Mark Dodds on this the 12th day of APRIL, 2017.

My Commission expires: 8/17/20

Judy B Anderson
NOTARY PUBLIC, STATE AT LARGE

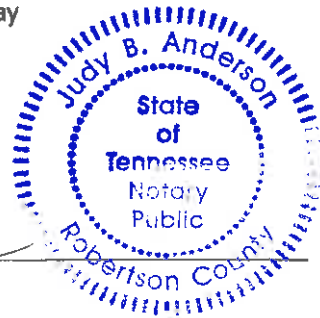

Please refer to Section II. Bid Conditions, Item "U" prior to completing this form.

I. GREEN PROCUREMENT

A. ENERGY

The Lexington-Fayette Urban County Government is committed to protecting our environment and being fiscally responsible to our citizens.

The Lexington-Fayette Urban County Government mandates the use of Energy Star compliant products if they are available in the marketplace (go to www.energystar.gov). If these products are available, but not submitted in your pricing, your bid will be rejected as non-compliant.

ENERGY STAR is a government program that offers businesses and consumers energy-efficient solutions, making it easy to save money while protecting the environment for future generations.

Key Benefits

- These products use 25 to 50% less energy
- Reduced energy costs without compromising quality or performance
- Reduced air pollution because fewer fossil fuels are burned
- Significant return on investment
- Extended product life and decreased maintenance

B. GREEN SEAL CERTIFIED PRODUCTS

The Lexington-Fayette Urban County Government is also committed to using other environmentally friendly products that do not negatively impact our environment. Green Seal is a non-profit organization devoted to environmental standard setting, product certification, and public education.

Go to www.GreenSeal.org to find available certified products. These products will have a reduced impact on the environment and on human health. The products to be used must be pre-approved by the LFUCG prior to commencement of any work in any LFUCG facility. If a Green Seal product is not available, the LFUCG must provide a signed waiver to use an alternate product. Please provide information on the Green Seal products being used with your bid response.

C. GREEN COMMUNITY

The Lexington-Fayette Urban County Government (LFUCG) serves as a principal, along with the University of Kentucky and Fayette County Public Schools, in the Bluegrass Partnership for a Green Community. The Purchasing Team component of the Partnership collaborates on economy of scale purchasing that promotes and enhances environmental initiatives. Specifically, when applicable, each principal is interested in obtaining best value products and/or services which promote environment initiatives via solicitations and awards from the other principals.

If your company is the successful bidder on this Invitation For Bid, do you agree to extend the same product/service pricing to the other principals of the Bluegrass Partnership for a Green Community (i.e. University of Kentucky and Fayette County Schools) if requested?

Yes No
mn

II. Bid Conditions

- A. No bid may be withdrawn for a period of sixty (60) days after the date and time set for opening.
- B. No bid may be altered after the date and time set for opening. In the case of obvious errors, the Division of Central Purchasing may permit the withdrawal of a bid. The decision as to whether a bid may be withdrawn shall be that of the Division of Central Purchasing.
- C. Acceptance of this proposal shall be enactment of an Ordinance by the Urban County Council.
- D. The bidder agrees that the Urban County Government reserves the right to reject any and all bids for either fiscal or technical reasons, and to award each part of the bid separately or all parts to one vendor.
- E. Minor exceptions may not eliminate the bidder. The decision as to whether any exception is minor shall be entirely that of the head of the requisitioning Department or Division and the Director of the Division of Central Purchasing. The Urban County Government may waive technicalities and informalities where such waiver would best serve the interests of the Urban County Government.
- F. Manufacturer's catalogue numbers, trade names, etc., where shown herein are for descriptive purposes and are to guide the bidder in interpreting the standard of quality, design, and performance desired, and shall not be construed to exclude proposals based on furnishing other types of materials and/or services. However, any substitution or departure proposed by the bidder must be clearly noted and described; otherwise, it will be assumed that the bidder intends to supply items specifically mentioned in this Invitation for Bids.
- G. The Urban County Government may require demonstrations of the materials proposed herein prior to acceptance of this proposal.
- H. Bids must be submitted on this form and must be signed by the bidder or his authorized representative. Unsigned bids will not be considered.
- I. Bids must be submitted prior to the date and time indicated for opening. Bids submitted after this time will not be considered.
- J. All bids mailed must be marked on the face of the envelope:

"Bid on #52-2017 Hooklift Loader Body"

and addressed to: Division of Central Purchasing
 200 East Main Street, Room 338
 Lexington, Kentucky 40507

The Lexington-Fayette Urban County Government assumes no responsibility for bids that are not addressed and delivered as indicated above. Bids that are not delivered to the Division of Central Purchasing by the stated time and date will be rejected.

- K. Bidder is requested to show both unit prices and lot prices. In the event of error, the unit price shall prevail.
- L. A certified check or Bid Bond in the amount of XX percent of the bid price must be attached hereto. This check must be made payable to the Lexington-Fayette Urban County Government, and will be returned when the material and/or services specified herein have been delivered in accordance with specifications. In the event of failure to perform within the time period set forth in this bid, it is agreed the certified check may be cashed and the funds retained by the Lexington-Fayette Urban County Government as liquidated damages. Checks of unsuccessful bidders will be returned when the bid has been awarded.
- M. The delivery dates specified by bidder may be a factor in the determination of the successful bidder.
- N. Tabulations of bids received may be mailed to bidders. Bidders requesting tabulations must enclose a stamped, self-addressed envelope with the bid.
- O. The Lexington-Fayette Urban County Government is exempt from Kentucky Sales Tax and Federal Excise Tax on materials purchased from this bid invitation. Materials purchased by the bidder for construction projects are not tax exempt and are the sole responsibility of the bidder.
- P. All material furnished hereunder must be in full compliance with OSHA regulations.

- Q. If more than one bid is offered by one party, or by any person or persons representing a party, all such bids shall be rejected.
- R. Signature on the face of this bid by the Bidder or his authorized representative shall be construed as acceptance of and compliance with all terms and conditions contained herein.
- S. The Entity (regardless of whether construction contractor, non-construction contractor or supplier) agrees to provide equal opportunity in employment for all qualified persons, to prohibit discrimination in employment because of race, color, creed, national origin, sex or age, and to promote equal employment through a positive, continuing program from itself and each of its sub-contracting agents. This program of equal employment opportunity shall apply to every aspect of its employment policies and practices.
- T. The Kentucky Equal Employment Opportunity Act of 1978 (KRS 45.560-45.640) requires that any county, city, town, school district, water district, hospital district, or other political subdivision of the state shall include in directly or indirectly publicly funded contracts for supplies, materials, services, or equipment hereinafter entered into the following provisions:

During the performance of this contract, the contractor agrees as follows:

- (1) The contractor will not discriminate against any employee or applicant for employment because of race, color, religion, sex, age or national origin;*
- (2) The contractor will state in all solicitations or advertisements for employees placed by or on behalf of the contractors that all qualified applicants will receive consideration for employment without regard to race, color, religion, sex, age or national origin;*
- (3) The contractor will post notices in conspicuous places, available to employees and applicants for employment, setting forth the provisions of the non-discrimination clauses required by this section; and*
- (4) The contractor will send a notice to each labor union or representative of workers with which he has a collective bargaining agreement or other contract or understanding advising the labor union or workers' representative of the contractor's commitments under the nondiscrimination clauses.*

The Act further provides:

KRS 45.610. Hiring minorities - Information required

- (1) For the length of the contract, each contractor shall hire minorities from other sources within the drawing area, should the union with which he has collective bargaining agreements be unwilling to supply sufficient minorities to satisfy the agreed upon goals and timetable.*
- (2) Each contractor shall, for the length of the contract, furnish such information as required by KRS 45.560 to KRS 45.640 and by such rules, regulations and orders issued pursuant thereto and will permit access to all books and records pertaining to his employment practices and work sites by the contracting agency and the department for purposes of investigation to ascertain compliance with KRS 45.560 to 45.640 and such rules, regulations and orders issued pursuant thereto.*

KRS 45.620. Action against contractor - Hiring of minority contractor or subcontractor

- (1) If any contractor is found by the department to have engaged in an unlawful practice under this chapter during the course of performing under a contract or subcontract covered under KRS 45.560 to 45.640, the department shall so certify to the contracting agency and such certification shall be binding upon the contracting agency unless it is reversed in the course of judicial review.*
- (2) If the contractor is found to have committed an unlawful practice under KRS 45.560 to 45.640, the contracting agency may cancel or terminate the contract, conditioned upon a program for future compliance approved by the contracting agency and the department. The contracting agency may declare such a contractor ineligible to bid on further contracts with that agency until such time as the contractor complies in full with the requirements of KRS 45.560 to 45.640.*

- (3) *The equal employment provisions of KRS 45.560 to 45.640 may be met in part by a contractor by subcontracting to a minority contractor or subcontractor. For the provisions of KRS 45.560 to 45.640, a minority contractor or subcontractor shall mean a business that is owned and controlled by one or more persons disadvantaged by racial or ethnic circumstances.*

KRS 45.630 Termination of existing employee not required, when

Any provision of KRS 45.560 to 45.640 notwithstanding, no contractor shall be required to terminate an existing employee upon proof that that employee was employed prior to the date of the contract.

KRS 45.640 Minimum skills

Nothing in KRS 45.560 to 45.640 shall require a contractor to hire anyone who fails to demonstrate the minimum skills required to perform a particular job.

It is recommended that all of the provisions above quoted to be included as special conditions in each contract. In the case of a contract exceeding \$250,000, the contractor is required to furnish evidence that his work-force in Kentucky is representative of the available work-force in the area from which he draws employees, or to supply an Affirmative Action plan which will achieve such representation during the life of the contract.

- U. Any party, firm or individual submitting a proposal pursuant to this invitation must be in compliance with the requirements of the Lexington-Fayette Urban County Government regarding taxes and fees before they can be considered for award of this Invitation and must maintain a "current" status with regard to those taxes and fees throughout the term of the contract. The contractor must be in compliance with Chapter 13 from the Code of Ordinances of the Lexington-Fayette Urban County Government. The contractor must be in compliance with Ordinance 35-2000 pursuant to contractor registration with the Division of Building Inspection. If applicable, said business must have a Fayette County business license.

Pursuant to KRS 45A.343 and KRS 45A.345, the contractor shall

- (1) *Reveal any final determination of a violation by the contractor within the previous five year period pursuant to KRS Chapters 136 (corporation and utility taxes), 139 (sales and use taxes), 141 (income taxes), 337 (wages and hours), 338 (occupational safety and health of employees), 341 (unemployment and compensation) and 342 (labor and human rights) that apply to the contractor; and*
- (2) *Be in continuous compliance with the above-mentioned KRS provisions that apply to the contractor for the duration of the contract.*

A contractor's failure to reveal the above or to comply with such provisions for the duration of the contract shall be grounds for cancellation of the contract and disqualification of the contractor from eligibility for future contracts for a period of two (2) years.

- V. Vendors who respond to this invitation have the right to file a notice of contention associated with the bid process or to file a notice of appeal of the recommendation made by the Director of Central Purchasing resulting from this invitation.

Notice of contention with the bid process must be filed within 3 business days of the bid/proposal opening by (1) sending a written notice, including sufficient documentation to support contention, to the Director of the Division of Central Purchasing or (2) submitting a written request for a meeting with the Director of Central Purchasing to explain his/her contention with the bid process. After consulting with the Commissioner of Finance the Chief Administrative Officer and reviewing the documentation and/or hearing the vendor, the Director of Central Purchasing shall promptly respond in writing findings as to the compliance with bid processes. If, based on this review, a bid process irregularity is deemed to have occurred the Director of Central Purchasing will consult with the Commissioner of Finance, the Chief Administrative Officer and the Department of Law as to the appropriate remedy.

Notice of appeal of a bid recommendation must be filed within 3 business days of the bid recommendation by (1) sending a written notice, including sufficient documentation to support appeal, to the Director, Division of Central Purchasing or (2) submitting a written request for a meeting with the Director of Central

Purchasing to explain his appeal. After reviewing the documentation and/or hearing the vendor and consulting with the Commissioner of Finance and the Chief Administrative Officer, the Director of Central Purchasing shall in writing, affirm or withdraw the recommendation.

III. Procurement Contract Bid Conditions

- A. The terms of this agreement shall be for 1 year(s) from the date of acceptance of this contract by the Lexington-Fayette Urban County Government. This agreement may be automatically extended for an additional 1 year(s) renewal. This contract may be canceled by either party thirty (30) days after delivery by cancelling party of written notice of intent to cancel to the other contracting party.
- B. Price Changes (**Space Checked Applies**)
 - (XXX) 1. Prices quoted in response to the Invitation shall be firm prices for the first 90 days of the Procurement Contract. After 90 days, prices may be subject to revision and such changes shall be based on general industry changes. Revision may be either increases or decreases and may be requested by either party. There will be no more than one (1) price adjustment per quarter. Requests for price changes shall be received in writing at least twenty (20) days prior to the effective date and are subject to written acceptance before becoming effective. Proof of the validity of a request for revision shall be responsibility of the requesting party. The Lexington-Fayette Urban County Government shall receive the benefit of any decline that the seller shall offer his other accounts.
 - () 2. No provision for price change is made herein. Prices are to be firm for the term of this contract.
 - () 3. Procurement Level Contract
- C. If any contract item is not available from the vendor, the Lexington-Fayette Urban County Government, at its option, may permit the item to be back-ordered or may procure the item on the open market.
- D. All invoices must bear reference to the Lexington-Fayette Urban County Government Purchasing document numbers which are being billed.
- E. This contract may be canceled by the Lexington-Fayette Urban County Government if it is determined that the Bidder has failed to perform under the terms of this agreement, such cancellation to be effective upon receipt of written notice of cancellation by the Bidder.
- F. No substitutions for articles specified herein may be made without prior approval of the Division of Central Purchasing.

EQUAL OPPORTUNITY AGREEMENT

The Law

- Title VII of the Civil Rights Act of 1964 (amended 1972) states that it is unlawful for an employer to discriminate in employment because of race, color, religion, sex, age (40-70 years) or national origin.
- Executive Order No. 11246 on Nondiscrimination under Federal contract prohibits employment discrimination by contractor and sub-contractor doing business with the Federal Government or recipients of Federal funds. This order was later amended by Executive Order No. 11375 to prohibit discrimination on the basis of sex.
- Section 503 of the Rehabilitation Act of 1973 states:

The Contractor will not discriminate against any employee or applicant for employment because of physical or mental disability.

- Section 2012 of the Vietnam Era Veterans Readjustment Act of 1973 requires Affirmative Action on behalf of disabled veterans and veterans of the Vietnam Era by contractors having Federal contracts.
- Section 206(A) of Executive Order 12086, Consolidation of Contract Compliance Functions for Equal Employment Opportunity, states:

The Secretary of Labor may investigate the employment practices of any Government contractor or sub-contractor to determine whether or not the contractual provisions specified in Section 202 of this order have been violated.

The Lexington-Fayette Urban County Government practices Equal Opportunity in recruiting, hiring and promoting. It is the Government's intent to affirmatively provide employment opportunities for those individuals who have previously not been allowed to enter into the mainstream of society. Because of its importance to the local Government, this policy carries the full endorsement of the Mayor, Commissioners, Directors and all supervisory personnel. In following this commitment to Equal Employment Opportunity and because the Government is the benefactor of the Federal funds, it is both against the Urban County Government policy and illegal for the Government to let contracts to companies which knowingly or unknowingly practice discrimination in their employment practices. Violation of the above mentioned ordinances may cause a contract to be canceled and the contractors may be declared ineligible for future consideration.

Please sign this statement in the appropriate space acknowledging that you have read and understand the provisions contained herein. Return this document as part of your application packet.

Bidders

I/We agree to comply with the Civil Rights Laws listed above that govern employment rights of minorities, women, veteran status, disability and age.



Signature



Name of Business

GENERAL PROVISIONS OF BID CONTRACT

By signing the below, bidder acknowledges that it understands and agrees with the following provisions related to its bid response and the provision of any goods or services to LFUCG upon selection by LFUCG pursuant to the bid request:

1. Bidder shall comply with all Federal, State & Local regulations concerning this type of service or good.
2. Failure to submit ALL forms and Information required by LFUCG may be grounds for disqualification.
3. Addenda: All addenda, if any, must be considered by the bidder in making its response, and such addenda shall be made a part of the requirements of the bid contract. Before submitting a bid response, it is incumbent upon bidder to be informed as to whether any addenda have been issued, and the failure of the bidder to cover any such addenda may result in disqualification of that response.
4. Bid Reservations: LFUCG reserves the right to reject any or all bid responses, to award in whole or part, and to waive minor immaterial defects in proposals. LFUCG may consider any alternative proposal that meets its basic needs.
5. Liability: LFUCG is not responsible for any cost incurred by bidder in the preparation of its response.
6. Changes/Alterations: Bidder may change or withdraw a proposal at any time prior to the opening; however, no oral modifications will be allowed. Only letters, or other formal written requests for modifications or corrections of a previously submitted proposal which is addressed in the same manner as the bid response, and received by LFUCG prior to the scheduled closing time for receipt of bids, will be accepted. The bid response when opened, will then be corrected in accordance with such written request(s), provided that the written request is contained in a sealed envelope which is plainly marked "modifications of bid response".
7. Clarification of Submittal: LFUCG reserves the right to obtain clarification of any point in a bid or to obtain additional information from any bidder.
8. Bribery Clause: By his/her signature on its response, bidder certifies that no employee of his/hers, any affiliate or subcontractor, has bribed or attempted to bribe an officer or employee of the LFUCG.
9. Additional Information: While not necessary, the bidder may include any product brochures, software documentation, sample reports, or other documentation that may assist LFUCG in better understanding and evaluating the bid response. Additional documentation shall not serve as a substitute for other documentation which is required by the LFUCG to be submitted with the bid response.
10. Ambiguity, Conflict or other Errors: If a bidder discovers any ambiguity, conflict, discrepancy, omission or other error in the bid request of LFUCG, it shall immediately notify LFUCG of such error in writing and request modification or clarification of the document if allowable by the LFUCG.
11. Agreement to Bid Terms: In submitting its bid response, the bidder agrees that it has carefully examined the specifications and all provisions relating to LFUCG's bid request, including but not limited to the bid contract. By submission of its bid response, bidder states that it understands the meaning, intent and requirements of LFUCG's bid request and agrees to the same. The successful bidder shall warrant that it is familiar with and understands all provisions herein and shall warrant that it can comply with them. No additional compensation to bidder shall be authorized for services, expenses, or goods reasonably covered under these provisions that the bidder omits from its bid response.
12. Cancellation: LFUCG may unilaterally terminate the bid contract with the selected bidder(s) at any time, with or without cause, by providing at least thirty (30) days advance written notice unless a different advance written notice period is negotiated prior to contract approval. Payment for services or goods received prior to termination shall be made by the LFUCG provided these goods or services were provided in a manner acceptable to the LFUCG. Payment for those goods and services shall not be unreasonably withheld.

13. **Assignment of Contract:** The selected bidder(s) shall not assign or subcontract any portion of the bid contract with LFUCG without the express written consent of LFUCG. Any purported assignment or subcontract in violation hereof shall be void. It is expressly acknowledged that LFUCG shall never be required or obligated to consent to any request for assignment or subcontract; and further that such refusal to consent can be for any or no reason, fully within the sole discretion of LFUCG.
14. **No Waiver:** No failure or delay by LFUCG in exercising any right, remedy, power or privilege hereunder, nor any single or partial exercise thereof, nor the exercise of any other right, remedy, power or privilege shall operate as a waiver hereof or thereof. No failure or delay by LFUCG in exercising any right, remedy, power or privilege under or in respect of this bid proposal or bid contract shall affect the rights, remedies, powers or privileges of LFUCG hereunder or shall operate as a waiver thereof.
15. **Authority to do Business:** Each bidder must be authorized to do business under the laws of the Commonwealth of Kentucky and must be in good standing and have full legal capacity to provide the goods or services specified in the bid proposal. Each bidder must have all necessary right and lawful authority to submit the bid response and enter into the bid contract for the full term hereof including any necessary corporate or other action authorizing the bidder to submit the bid response and enter into this bid contract. If requested, the bidder will provide LFUCG with a copy of a corporate resolution authorizing this action and/or a letter from an attorney confirming that the proposer is authorized to do business in the Commonwealth of Kentucky. All bid responses must be signed by a duly authorized officer, agent or employee of the bidder.
16. **Governing Law:** This bid request and bid contract shall be governed by and construed in accordance with the laws of the Commonwealth of Kentucky. In the event of any proceedings regarding this matter, the bidder agrees that the venue shall be the Fayette County Circuit Court or the U.S. District Court for the Eastern District of Kentucky, Lexington Division and that the bidder expressly consents to personal jurisdiction and venue in such Court for the limited and sole purpose of proceedings relating to these matters or any rights or obligations arising thereunder.
17. **Ability to Meet Obligations:** Bidder affirmatively states that there are no actions, suits or proceedings of any kind pending against bidder or, to the knowledge of the bidder, threatened against the bidder before or by any court, governmental body or agency or other tribunal or authority which would, if adversely determined, have a materially adverse effect on the authority or ability of bidder to perform its obligations under this bid response or bid contract, or which question the legality, validity or enforceability hereof or thereof.
18. Bidder understands and agrees that its employees, agents, or subcontractors are not employees of LFUCG for any purpose whatsoever. Bidder is an independent contractor at all times related to the bid response or bid contract.
19. If any term or provision of this bid contract shall be found to be illegal or unenforceable, the remainder of the contract shall remain in full force and such term or provision shall be deemed stricken.

Signature

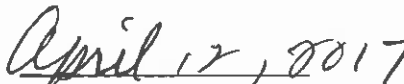
Date

1.0 SCOPE OF BID

- 1.1 This specification describes the minimum requirements for a 65,000 pound "Hooklift" loader body to be mounted on a new LFUCG supplied chassis. ✓

2.0 REQUIREMENTS

- 2.1 Hook lift loader body shall have a lifting/dumping capacity of not less than 65,000 pounds. Loader shall be designed to adequately dump bodies ranging from 20 to 24 feet in length. Loader manufacturer shall offer a variety of containers/bodies for use with their loader system such as debris boxes, recycling boxes, flat beds, dump beds, etc. *yes*
- 2.2 Hook lift loader shall operate hydraulically with controls in the truck cab. Hydraulic system shall utilize a front mounted, crankshaft driven, cast iron hydraulic pump. A dry valve shall control pump activation. No clutches shall be used to engage pump. Pump shall have sufficient capacity to operate all hydraulic functions of the body hoist, loader, and tarp system. Hoist mechanism shall utilize no less than two (2) double acting hydraulic lift cylinders having a minimum diameter of 7 ½ inches, and one (1) double acting hydraulic jib cylinder having a minimum diameter of 4 ½ inches. *yes*
- 2.3 Hydraulic reservoir tank shall have sufficient capacity to supply fluid to all hydraulic operations. Tank shall include fluid level indicator with integral thermometer, 100 mesh suction strainer with bypass relief, and a return filter assembly, with replaceable 10 micron filter cartage.
- 2.4 Tarp system shall be hydraulically operated and shall be installed to cover various size open top containers. System shall be fully hydraulic, covering and uncovering, controlled from within the truck cab. Tarp material shall be denier polyester weighing at least 15 oz. per sq. yard. Material shall be reinforced at edges and all stress points. *yes*
- 2.5 Lighting required by the Federal Motor Vehicle Safety Standard #108 shall be installed. All rear facing stop, tail, turn, or tail lamps shall be flush mounted, sealed LED units (such as Truck Lite 44982R). All clearance lamps shall be grommet mounted, sealed LED units (such as Truck Lite 10250R). License plate lamp shall be a sealed LED unit (such as Truck Lite 15226). Backup lamps shall be sealed LED units (such as Truck Lite 44806C). Two (2) LED lamp (such as Truck Lite 81360) used to illuminate the area behind the truck cab where container engagement takes place. This light shall be controlled by a switch in the truck cab. *yes*
- 2.6 Two (2) rear facing grommet mounted amber strobe lights shall be mounted in a manner consistent with other rear facing lights. Strobe lights shall be self-contained LED units (such as Truck Lite 44212Y). *yes*

3.0 NOTES

- 3.1 Unit furnished as required herein shall be physically inspected by LFUCG personnel before unit is accepted. Appropriate measures may be taken to insure compliance with specifications. ✓
- 3.2 The successful bidder shall pickup LFUCG supplied cab & chassis, and deliver back completed unit to LFUCG 669 Byrd Thurman Dr. Lexington, Ky. 40510. ✓

3.3 Unit shall be ready to operate upon delivery. ✓

4.0 GENERAL

4.1 Factory printed literature concerning the body, and tarp system which shall contain complete specifications and warranty shall be submitted with the bid and becomes an integral part of the bid. If literature submitted does not indicate compliance with specifications contained herein and your firm can meet these specifications by modifications, you must state this in writing, listing necessary modifications, and submit as part of bid. ✓

4.2 A purchase order for the purchase of the equipment described herein shall be made to the responsive and responsible bidder who can perform the contract requirements at the lowest unit price. ✓

4.3 Completed unit shall be new and unused, current model production. ✓

4.4 Successful bidder shall provide complete parts manuals for both the "HookLift" body and tarp assembly. ✓

4.5 Any and all methods of attachment to the frame rails of the truck shall conform to the truck manufacturer's recommendation. Flame cut holes are not permitted. ✓

4.6 Completed unit provided under this specification shall fully comply with any and all applicable OSHA and ANSI standards as well as all applicable Federal, State, and local laws, regulations, ordinances, resolutions, and codes at time of delivery. ✓

4.7 Pricing:

Price per unit as described herein \$ 48,298.⁰⁰



Growing with SwapLoader *400 Series Hoists*

From the beginning, SwapLoader Hoists have been built around the customer's ability to grow up or down in capacity. It's this foresight that has helped our customers utilize existing containers (free of alterations) when growing from small to large or large to small in hoist capacity that operate using similar body/container lengths.

Options like the Adjustable (Rotating) Jib and Container Variable System (CVS) have been added to assist these growing transitions. This product expansion never stops at SwapLoader. As our customer's needs continue to grow and evolve, so does SwapLoader.

Beyond SwapLoader's expanded line-up of options, turn your focus to our line-up of Sub-frames. The Sub-frame is the first and probably most important key to making it all work. Below we've provided some basic insight into each hoist. When helping your customers plan for the future, stay focused on the Sub-frames and their ability to be used with other hoist models. Understanding which Sub-frames work with which hoists, is essential in building your roadmap to future growth.

- **SL-330**
 - Jib Options:
 - Standard – fixed 62" hook height.
 - Option – adjustable (rotating) hook height of 54" & 62".
 - Designed to work with body lengths of 14' to 18'.
 - With CVS – works with body lengths of 12' to 18'.
 - Optimum body lengths are 14' to 16'.
 - Works with the following container setups:
 - **All SL-330/400 (400 Series) Sub-frames (62" hook height)**
 - **All SL-330/400 (300 Series) Sub-frames (54" hook height)**
 - **All SL-240/180/185 (200 Series) Sub-frames (54" hook height)**
 - **18' SL-406/545 (400 Series) Sub-frames (62" hook height)**
 - Body lengths that exceed the optimum may require additional SwapLoader options (bumper with extensions, folding bumper or drop-down bumper) to comply with I.C.C. Bumper Regulations.

Continued...

- **SL-400**

- Jib Options:
 - Standard – fixed 62" hook height.
 - Option – adjustable (rotating) hook height of 54" & 62".
- Designed to work with body lengths of 14' to 18'.
- With CVS – works with body lengths of 12' to 18'.
- Optimum body lengths are 14' to 16'.
- Works with the following container setups:
 - **All SL-330/400 (400 Series) Sub-frames (62" hook height)**
 - **All SL-330/400 (300 Series) Sub-frames (54" hook height)**
 - **All SL-240/180/185 (200 Series) Sub-frames (54" hook height)**
 - **18' SL-406/545 (400 Series) Sub-frames (62" hook height)**
- Body lengths that exceed the optimum may require additional SwapLoader options (bumper with extensions, folding bumper or drop-down bumper) to comply with I.C.C. Bumper Regulations.

- **SL-406**

- Jib Options:
 - Standard – fixed 62" hook height.
 - Option – adjustable (rotating) hook height of 54" & 62".
- Designed to work with body lengths of 18' to 22'.
- With CVS – works with body lengths of 16' to 22'.
- Optimum body lengths are 18' to 20'.
- Works with the following container setups:
 - **All SL-406/545 (400 Series) Sub-frames (62" hook height)**
 - **All SL-406 (300 Series) Sub-frames (54" hook height)**
 - **All SL-220/222 (200 Series) Sub-frames (54" hook height)**
 - **19' to 22' SL-505/650 (400 Series) Sub-frames (62" hook height)**
- Body lengths that exceed the optimum may require additional SwapLoader options (bumper with extensions, folding bumper or drop-down bumper) to comply with I.C.C. Bumper Regulations.

- **SL-505**

- Jib – fixed 62" hook height.
- Designed to work with body lengths of 19' to 24'.
- Optimum body lengths are 19' to 22'.
- Works with the following container setups:
 - **All SL-505/650 (400 Series) Sub-frames (62" hook height)**
- Body lengths that exceed the optimum may require additional SwapLoader options (bumper with extensions, folding bumper or drop-down bumper) to comply with I.C.C. Bumper Regulations.

- **SL-545**

- Jib – fixed 62" hook height.
- Designed to work with body lengths of 17' to 22'.
- Optimum body lengths are 17' to 20'.
- Works with the following container setups:
 - **All SL-406/545 (400 Series) Sub-frames (62" hook height)**
 - **19' to 22' SL-505/650 (400 Series) Sub-frames (62" hook height)**
- Body lengths that exceed the optimum may require additional SwapLoader options (bumper with extensions, folding bumper or drop-down bumper) to comply with I.C.C. Bumper Regulations.

Continued...

• **SL-650**

- Jib – fixed 62" hook height.
- Designed to work with body lengths of 20' to 24'.
- Optimum body lengths are 20' to 22'.
- Works with the following container setups:
 - **All SL-505/650 (400 Series) Sub-frames (62" hook height)**
- Body lengths that exceed the optimum may require additional SwapLoader options (bumper with extensions, folding bumper or drop-down bumper) to comply with I.C.C. Bumper Regulations.

For more details, refer to the 400 Series Sub-frame Drawing.
 This can be found in your Field Sales Books or in the Distributor Login area of our website.

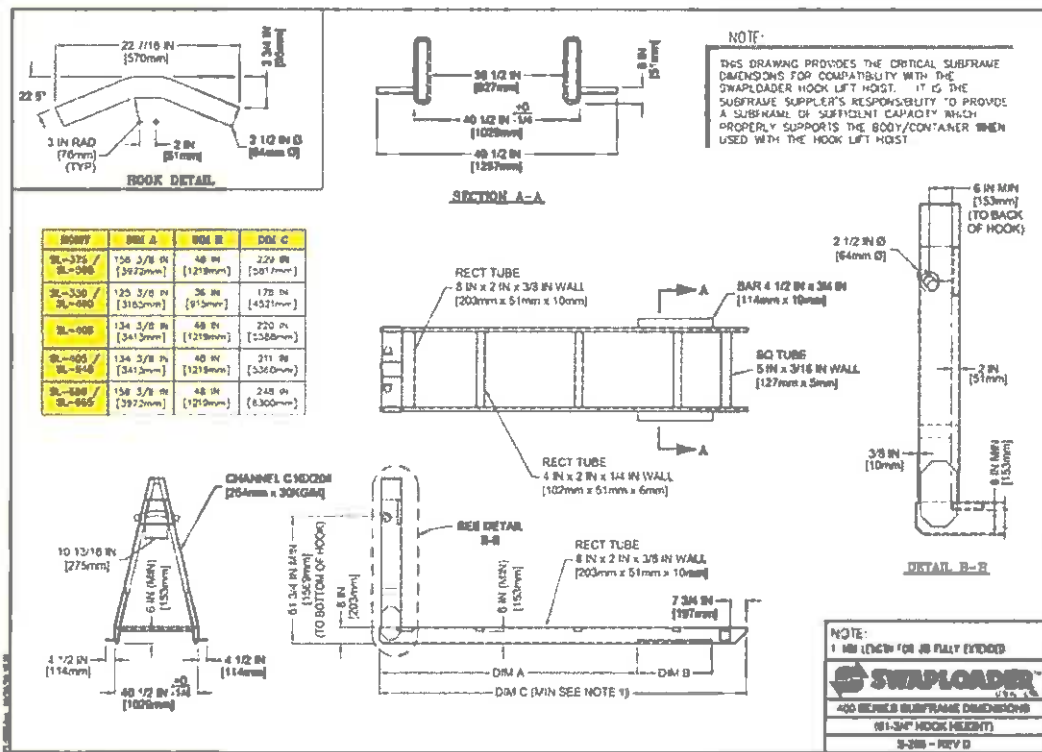

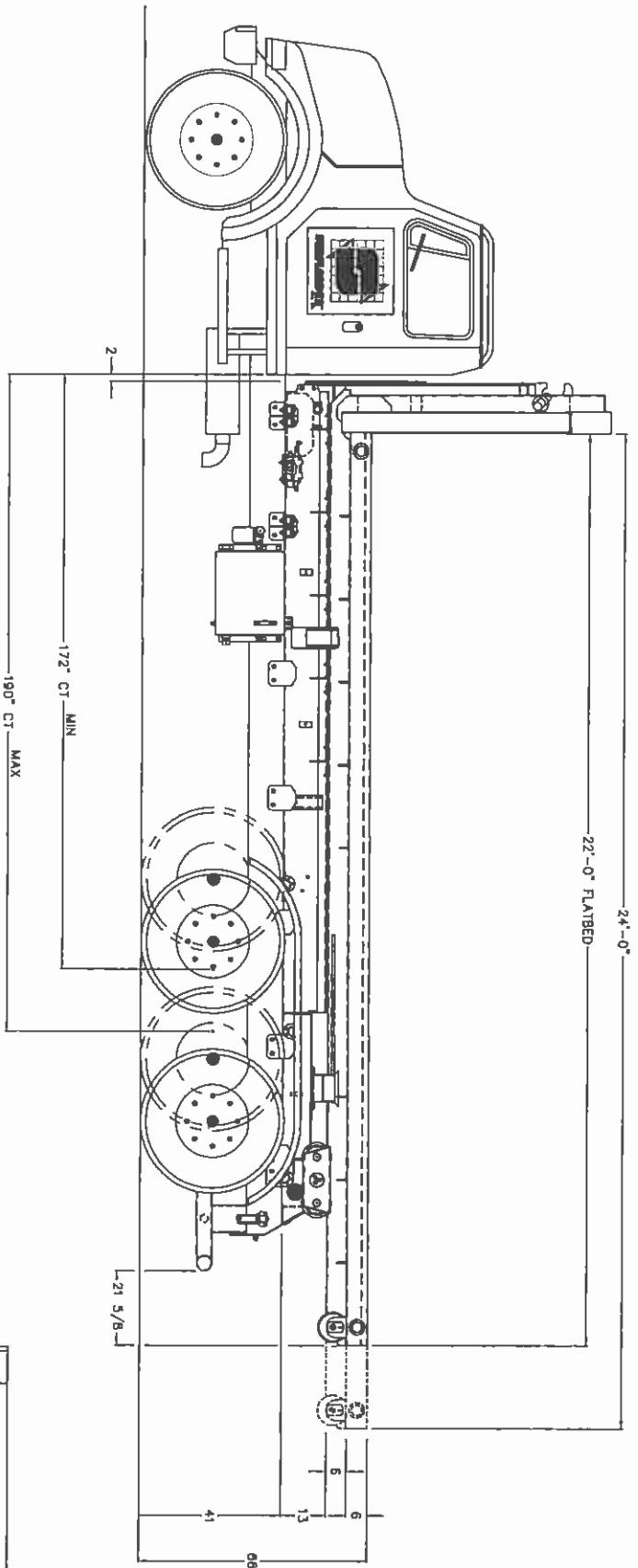

SCALE
(Inches)

12 24 36 48 60 72 84 96

NOTE:

THIS DRAWING IS DONE SOLELY TO ILLUSTRATE THE POSITIONING AND INSTALLATION OF THE SWAPLOADER HOST ON A TRUCK CHASSIS WITH PARTICULAR DIMENSIONS AS SHOWN. IT IS THE CUSTOMER'S OR DISTRIBUTOR'S RESPONSIBILITY TO PERFORM CALCULATIONS FOR PROPER WEIGHT DISTRIBUTION, HOIST CLEARANCE, AND OPERATION OF THE COMPLETED CHASSIS SO THAT IT MEETS OR EXCEEDS ALL FEDERAL, STATE AND LOCAL REGULATIONS.

GENERAL NOTES

1. ALL ATTENTION ON REPAIR OR MAINTENANCE EQUIPMENT MUST BE DIRECTED TO THE SWAPLOADER USA, LTD. AND NOT TO THE TRUCK CHASSIS OR EQUIPMENT OTHER THAN AS SHOWN HEREON.
2. THIS DRAWING IS THE PROPERTY OF SWAPLOADER USA, LTD. AND IS LOANED TO THE CUSTOMER IN CONFIDENCE.
3. ALL DIMENSIONS ARE IN INCHES UNLESS OTHERWISE SHOWN.



HOST / CHASSIS ILLUSTRATION
S-650 W/ 22' FLAT BED

DESIGNED BY	4/80/DA DAK
CHECKED BY	9/7/74 DKS
DATE	
SCALE	
TITLE	
NO.	
REV.	
DATE	
BY	

DATE	3/8 = 12	SCALE	S-650
NO.		REV.	50650-100-2811

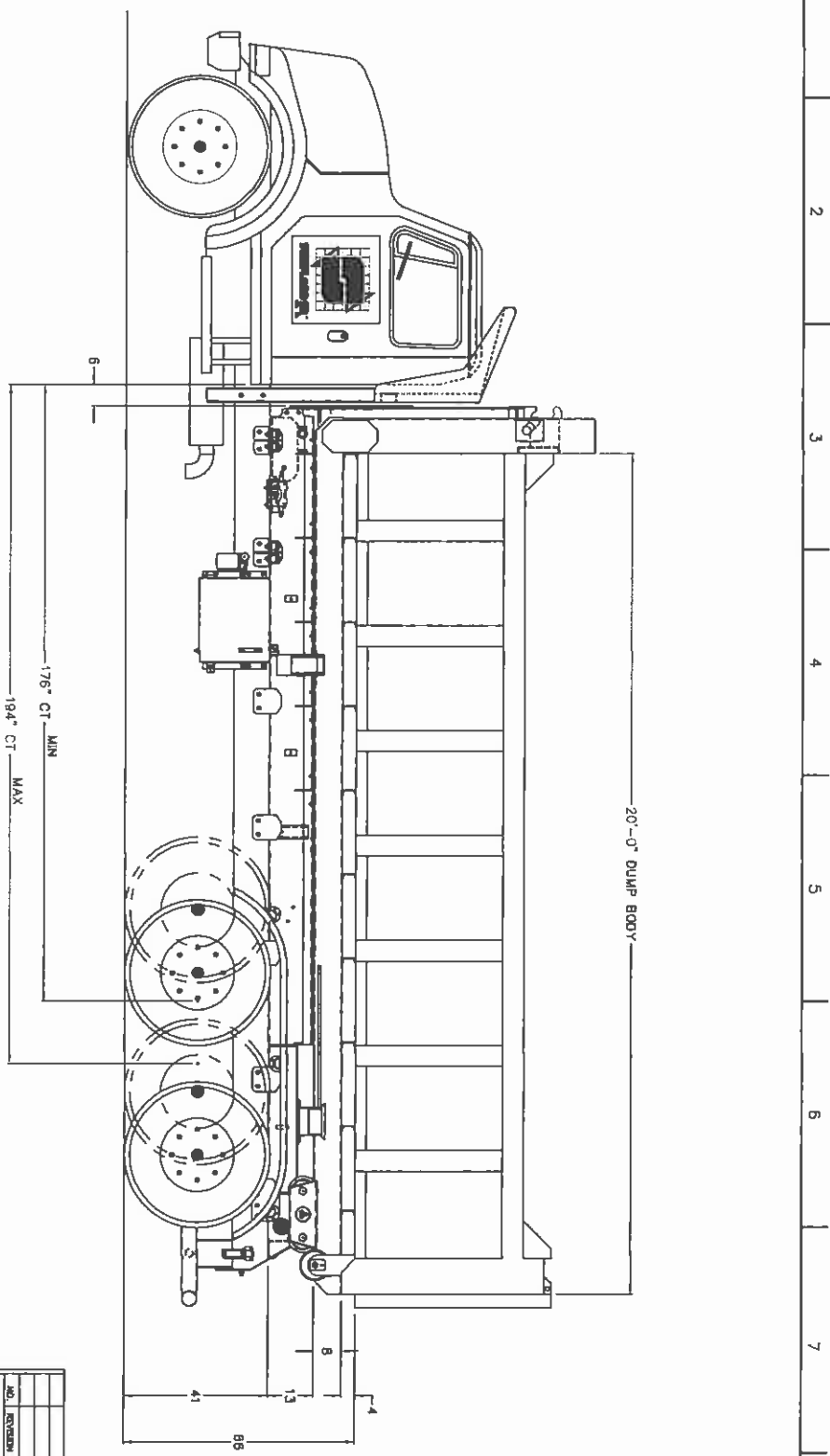

20'-0" DUMP BODY

176" CT MIN
194" CT MAX

SCALE
(Inches)
12 24 36 48 60 72 84 96

NOTE:

THIS DRAWING IS DONE SOLELY TO ILLUSTRATE THE POSITIONING AND INSTALLATION OF THE SWAPLOADER HOIST ON A TRUCK CHASSIS WITH PARTICULAR DIMENSIONS AS SHOWN. IT IS THE CUSTOMER'S OR DISTRIBUTOR'S RESPONSIBILITY TO PERFORM CALCULATIONS FOR PROPER WEIGHT DISTRIBUTION, HOIST CLEARANCE, AND OPERATION OF THE COMPLETED CHASSIS SO THAT IT MEETS OR EXCEEDS ALL FEDERAL, STATE, AND LOCAL REGULATIONS.

GENERAL NOTES

1. ANY ALTERATION OR REMOVAL OF SWAPLOADER EQUIPMENT MUST BE APPROVED BY THE MANUFACTURER'S REPRESENTATIVE OR DISTRIBUTOR. THE USER OF THIS EQUIPMENT OWNS THIS AS SHOWN AND ASSUMES ALL RESPONSIBILITIES.
2. THIS DRAWING IS THE PROPERTY OF SWAPLOADER USA, LTD. AND IS LOANED TO THE PURCHASER IN COMPLETE CONFIDENCE.
3. ALL DIMENSIONS ARE IN UNLESS OTHERWISE SPECIFIED.



HOST / CHASSIS ILLUSTRATION
S-650 W/ 20' DUMP BODY

REVISED BY	DATE	DESCRIPTION
4/8/74 DJK		
DESIGNED BY	DATE	DESCRIPTION
3/7/74 DJS		
DATE	FILE	
3/8	12	S-650
3/8	12	S-650
3/8	12	S-650

KENWORTH TRUCKS

An EFCO Company

&

SWAPLOADER[®]

"HOOKED ON QUALITY"

U.S.A. LTD.



- 100% In Cab Operation
- Ground Level Loading & Unloading
- Switch Applications In Less Than 3 Minutes
- True Dumping Capabilities
- Able To Share Hydraulic System
- Eliminate Seasonal Trucks
- Increased Productivity
- 4-Year ALL Parts & 1-Year Labor Warranty

SwapLoader has been building the highest quality hook-lift hoists since the late 1980's. Our goal from day one was to build the toughest piece of equipment on the market. A family of hoists guaranteed to lift rated capacity (with all stated body lengths) and will out live multiple chassis. Now that's a serious business investment you can hang your hat on!



**UNLIMITED VERSATILITY AND ADDED VALUE WITH
KENWORTH TRUCKS & SWAPLOADER!**



www.kenworth.com

www.swaploader.com

400 SERIES HEAVY DUTY

50,000 - 65,000 LBS. LIFT CAPACITY



- **4 year warranty**
- **Sliding jib**
- **Slide through body locks**
- **Large beveled rear rollers**
- **Dual pivot rear section**
- **Dual lift cylinders**
- **Nylatron slide pads**
- **Low pressure hydraulics**
- **Integral dual counter balance valves**
- **Designed and built in the USA**

400 SERIES HEAVY DUTY

U.S.A. LTD.

SWAPLOADER®
Concrete Mixers - Lintiscopers - Lumber Yards - Municipal - Governmental - Rental Yards - Roofers - Waste Handlers



MODEL	SL-505	SL-545	SL-650	
Model Description	Dump Capacity (Incl. container)	50,000 lb.	54,000 lb.	65,000 lb.
	Dump Angle	57°	57°	54°
	Lift Capacity (Incl. container)	50,000 lb.	54,000 lb.	65,000 lb.
	Hoist Wt.	6,750 lb.	6,640 lb.	8,050 lb.
General Dimensions (See Diagram)	Hook to Rear Roller (Dim. A)	219.0"	201.0"	226.5"
	Hook Height to bottom of bar (Dim. B) Adjustable Jib	61.75"	61.75"	61.75"
	Hoist Ht. (Dim. C)	12"	12"	13"
	Hoist Center of Gravity (Dim. D)	114.2"	110.4"	125.0"
	Body Length (Dim. E)	19' to 24' ②	17' to 22' ②	20' to 24' ②
	Optimum Body Lengths	19' - 22'	17' - 20'	20' - 22'
Hydraulic System	Body Longsill Width ③	40.5" or 41.75"	40.5" or 41.75"	40.5" or 41.75"
	Hydraulic Pump Type (CID)	Gear (5.48)	Gear (5.48)	Gear (5.48)
	Flow	32.0 GPM @ 1,500 RPM	32.0 GPM @ 1,500 RPM	32.0 GPM @ 1,500 RPM
	Relief Pressure	3,500 PSI	3,500 PSI	3,500 PSI
Lift Cylinder	Hydraulic Resvr.	30 gal.	30 gal.	30 gal.
	Type	All models incorporate twin, double acting cylinders with dual built-in counterbalance valves.		
	Quantity	2	2	2
Jib Cylinder	Bore	7" Ø	7" Ø	7.5" Ø
	Stroke	74"	74"	82"
	Type	All models incorporate a single, double acting cylinder with a single built-in counterbalance valve.		
Truck Specs (Recommended)	Quantity	1	1	1
	Bore	5" Ø	5" Ø	4.5" Ø
	Stroke	52"	48"	52"
	GVW Range	50,000 lb. or greater	50,000 lb. or greater	55,000 lb. or greater
PTO Specs (Recommended)	Cab - Axle Dim. (Single Axle) ④	N/A	N/A	N/A
	Cab - Trunion Dim. (Tandem Axle) ④	176" to 190"	165" to 174"	172" to 190"
	Truck Frame RBM (Each Channel)	2,500,000 in. lb.	2,500,000 in. lb.	2,750,000 in. lb.
	Clear Frame Rail ⑤	241"	225"	249"
PTO Specs (Recommended)	Frame Height	up to 45"	up to 45"	up to 45"
	Type	Driveline	Driveline	Driveline
	Rotation	PTO rotation is determined by make & model of transmission.		
Torque Required	260 ft-lbf	260 ft-lbf	260 ft-lbf	
PTO Ratio ⑥	80 - 120%	80 - 120%	80 - 120%	

- 4 year warranty
- Sliding Jib
- Slide through body locks
- Large beveled rear rollers
- Dual pivot rear section
- Rugged main frame
- Dual lift cylinders
- Nylatron slide pads
- Low pressure hydraulics
- Rigorous 4 year test cycle
- Integral Dual Counter Balance Valves
- Designed and Built in the USA

- 1 Jib Lock out valve to prevent jib operation in dump mode standard.
- 2 Hoist with longer bodies may not conform with I.C.C. bumper regulations or may not achieve maximum dump angle depending on truck chassis height. Contact your SwapLoader distributor for more information.
- 3 Maximum outside to outside longsill width.
- 4 Optimum CA/CT dimension will be influenced by type of loads carried and turning radius requirements.
- 5 Clear frame Dim given is the overall length of hoist plus 5" for cab clearance and rear light bar mounting. Additional frame length may be necessary for other accessories such as cab guard, tarper, exhaust system, etc.
- 6 PTO ratio may impact output flow of pump at given engine rpm.

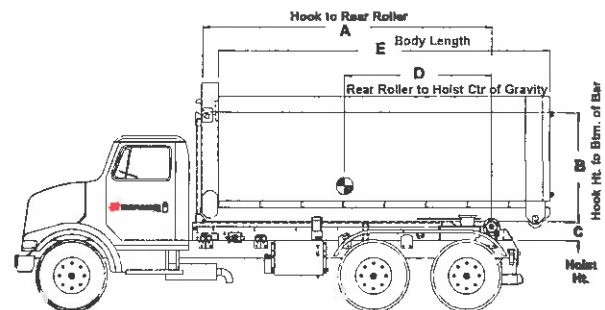

SwapLoader USA, Ltd.
1800 N.E. Broadway Ave.
Des Moines, IA 50313
Ph: 515-266-3042
Fax: 515-313-4426
Toll Free: 888-767-8000

Your authorized SwapLoader dealer

Ask about the wide range of available SwapLoader models

Refuse Systems

Rack 'n Pinion Strong Arm™ RP4500SAR/SARG P

This Rack 'n Pinion tarp system has been the system of choice in the roll-off industry for over ten years. Our patented hydraulic arms and gear assembly combined with our Strong Arm technology and Everlast Tarp Roller produce the only fully hydraulic system known for reliability and low maintenance. The Strong Arm concept uses a greatly strengthened base arm which attaches to the Rack 'n Pinion pivot. The extended "C" Channel provides better leverage, greater control and longer life.

- For roll-off trucks hauling different height containers
- Patented Rack 'n Pinion pivot assembly for consistently precise tarp movement
- Stronger arms provide longer life: 3/16 A500B steel with ¼" extended, reinforced "C" Channel
- Telescoping arms have 36" stroke and nitrited rod cylinders for minimized corrosion and longer life
- Quick tarp attachment
- Cylinders mounted externally for maximum accessibility and maintenance
- Spring loaded Everlast roller assembly
- Offset stabilizer bar virtually eliminates roller damage
- Ratchet and pawl system for safer tarp installation
- Heavy Duty mesh tarp
- Fixed gantry (SAR)
- Hydraulic gantry (SARG)

3 YEAR non-prorated warranty against system mechanical defects - Best In Industry

Patent #: 5,829,818 & 4,874,196





This Rack 'n Pinion™ tarping system has been the system of choice in the roll-off industry for over a decade. Our patented hydraulic arms and gear assembly combined with our "Strong Arm" technology and Everlast Tarp Roller produce the only fully hydraulic system known for reliability and low maintenance. The reinforced "C" Channel provides better leverage, greater control and longer life. Look for the Rack 'n Pinion tombstone as a symbol of Pioneer's industry leading tarping system.

Applications: Cable hoist roll-off trailers

Container style/size: Up to 32 foot containers

Standard tarp: Heavy duty mesh

Request Information

- [FEATURES](#)
- [OPTIONS](#)
 - Stronger tarp arms 3/16" A5 steel with reinforced "C" channel
 - Telescoping arms with 36" stroke and nitrited rod cylinders minimize corrosion and provide longer life
 - Spring loaded Everlast roller assembly
 - Quick tarp attachment
 - Ratchet and pawl design for faster installation and easier tarp installation
 - Arms feature external cylinders for easier accessibility and maintenance
 - Offset stabilizer bar virtually eliminates roller damage
 - Telescopic arms cover containers of various heights (up to 8') and lengths (up to 24')
 - Industry leading 3-year warranty covers the entire system (excludes tarp material)
 - Adjustable gantry moves vertically from 60 to 90 inches
 - Roller mounted on gantry means less weight aloft which results in less stress on the framework
 - Backed by an industry-leading 3-year non-prorated warranty

