

NOTIFICATION MAP (SCALE = 1":200')

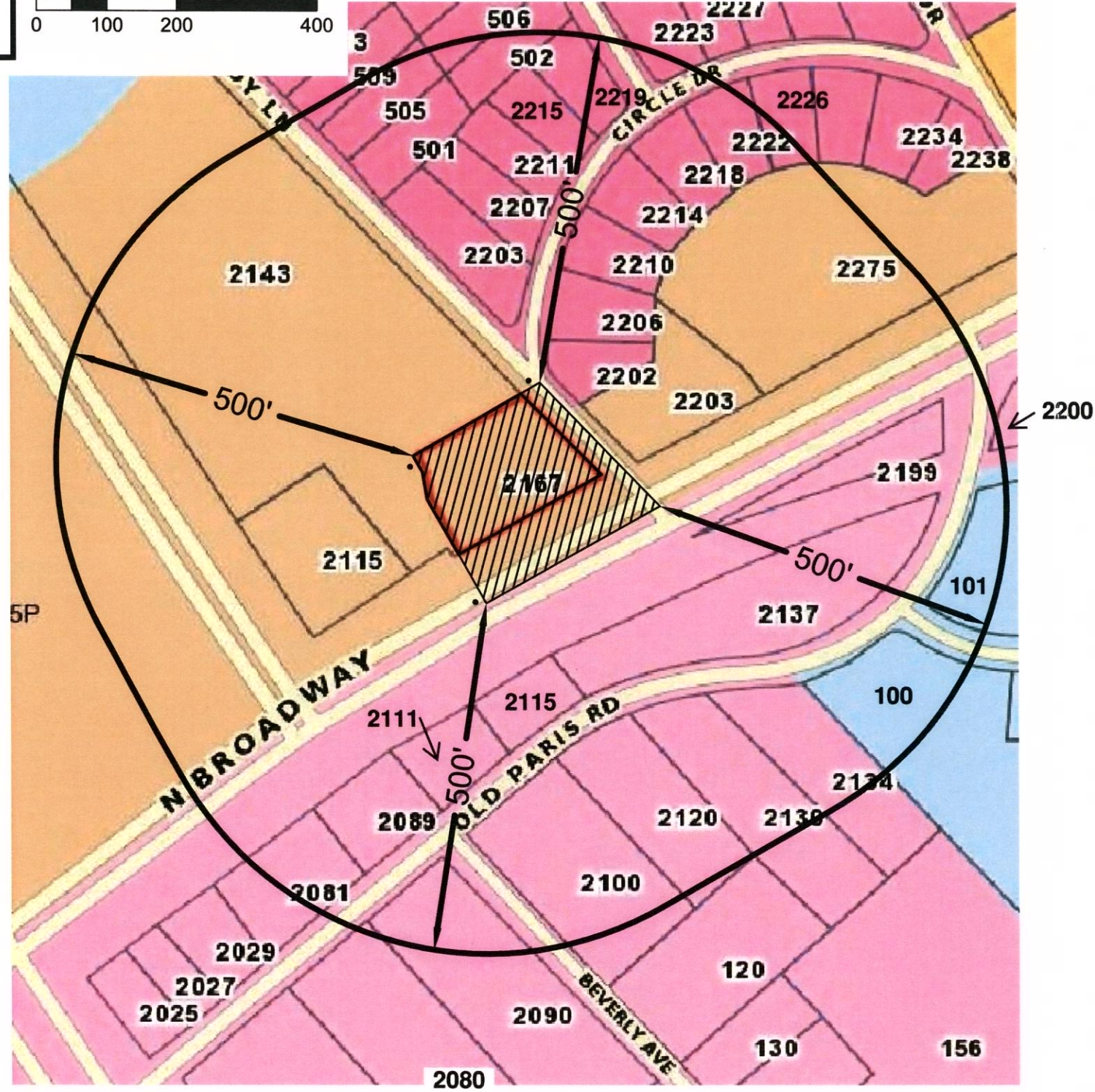

ZONING LEGEND

 = 5-BP	 = R3
 = R1-C	 = B-3
 = R1-B	

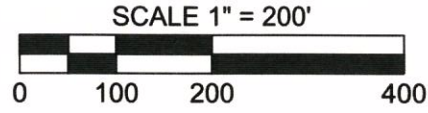
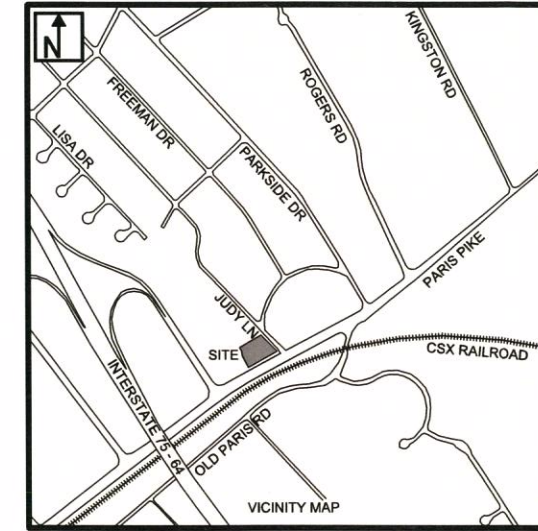

VICINITY MAP (N.T.S)

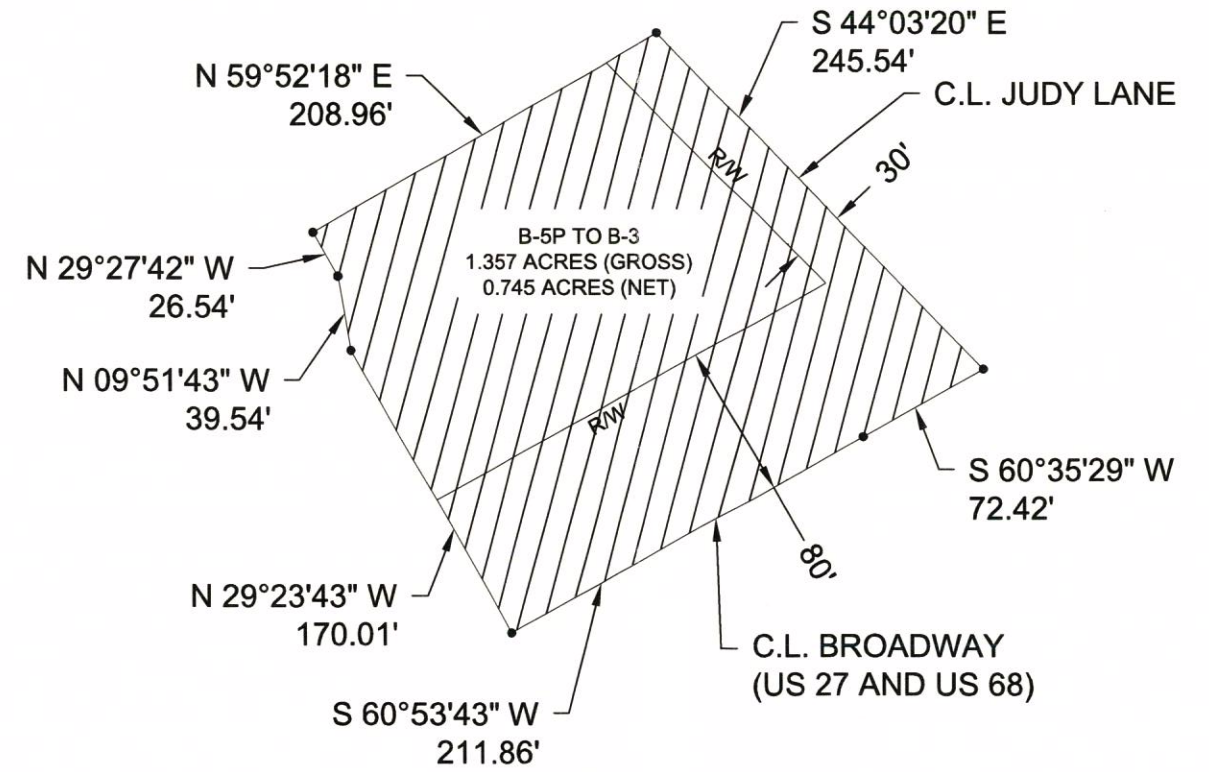
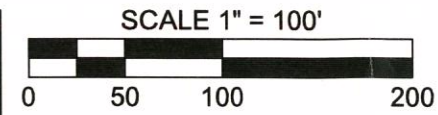
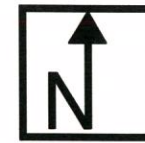

PROPERTY MAP (SCALE = 1":100')



ZOMAR: B-5P TO B3	FROM	TO	GROSS	NET
PROPERTY ADDRESS: 2167 N BROADWAY	B-5P	B3	1.357 AC	0.745 AC
APPLICANT: DAVID MYERS 150 SCENIC VIEW DRIVE CORBIN, KY 40701				
PROPERTY ADDRESS: VANTAGE ENGINEERING, PLC.				
DATE PREPARED: NOVEMBER 16, 2016			TOTAL 1.357 AC	0.745 AC