

LEXINGTON-FAYETTE URBAN COUNTY GOVERNMENT CONTRACT CHANGE ORDER Page 1 of 2		Date:	March 25, 2016
		Project:	Senior Citizen Center Construction
		Location:	Lexington
To (Contractor): Marrillia Design & Construction 259 West Short Street Suite 325 Lexington, KY 40507		Contract No.	227-2014
		Original Contract Amt.	\$8,882,900.00
		Cumulative Amount of Previous Change Orders	\$1,436,423.37
		Percent Change - Previous Change Orders	16.17%
		Total Contract Amount Prior to this Change Order	\$10,319,323.37
		Change Order No.	37
You are hereby requested to comply with the following changes from the contract plans and specification;			
Current Change Order			
Item No.	Description of changes-quantities, unit prices, change in completion date, etc.	Decrease in contract price	Increase in contract price
1	Wrap exposed beam in Conference 241 per PR 059		\$813.00
2	Add waterproofing at storage building per PR 061		\$3,486.00
	Total decrease	\$0.00	
	Total increase		\$4,299.00
	Net Amount of this Change Order	\$4,299.00	
	New Contract Amount Including this Change Order	\$10,323,622.37	
	Percent Change - This Change Order		0.05%
	Percent Change - All Change Orders		16.22%
The time provided for the completion in the contract and all provisions of the contract will apply hereto.			
Recommended by	<i>Joyce Thomas</i>	(Project Manager)	Date 3/25/16
Accepted by	<i>Josh Marrillia</i>	(Contractor)	Date 3/28/16
Approved by	<i>Jeffrey R. ...</i>	(Director)	Date 3/28/16
Approved by	<i>Jeffrey R. ...</i>	(Commissioner)	Date 3/28/16
Approved by	<i>Jeff Smith</i>	(Mayor or CAO)	Date 3/30/16

JUSTIFICATION FOR CHANGE

PROJECT: Senior Citizen Center Construction

CONTRACT NO. 227-2014

CHANGE ORDER NO. 37

1. Necessity for change: A steel beam in 241 is exposed due to a design coordination issue. The drywall soffit will conceal the beam and not affect the function of the room. The design for the storage building lacked adequate waterproofing to maintain a dry space. This added waterproofing will ensure that the building stays dry inside.
2. Is proposed change an alternate bid? ___ Yes X No
3. Will proposed change alter the physical size of the project? ___ Yes X No
If "Yes", explain.
4. Effect of this change on other prime contractors: N/A
5. Has consent of surety been obtained? ___ Yes X Not Necessary
6. Will this change affect expiration or extent of insurance coverage? ___ Yes X No
If "Yes", will the policies be extended? ___ Yes ___ No
7. Effect on operation and maintenance costs:
8. Effect on contract completion date: 0 working days

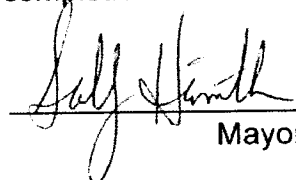

Mayor

3/30/16

Date



Lexington-Fayette Urban County Government
DEPARTMENT OF GENERAL SERVICES

TRANSMITTAL

Date: March 30, 2016

Contract Number: 227-2014

Purchase Order Number: LF00120278

Bid Package Number: 99-2014

Capital Project Number: TBD

Work Order Number: N/A

Building: Senior Citizen Center

Project Description: Replacement Senior Citizen Center Construction

To: Josh Marrillia, Marrillia Design & Construction RE: Change Order #37 fully executed

CC: Harding Dowell, EOP
Trina Brown, Social Services (2600-606101-6001-90511, SR_CITZN2_2015)
Sharon Jones, Council Clerk's Office

From: Joyce Thomas, General Services *Joyce*

We Are Sending You:

- Contract
- Warranties
- Payment Application
- Operation and Maintenance Manuals
- Change Order
- Plans

Item	Copies	Description	Pages	Date
1.	1	Change Order #37 fully executed	11	3/30/2016

THESE ARE TRANSMITTED AS INDICATED BELOW:

- FOR APPROVAL
- FOR YOUR USE
- FOR YOUR REVIEW AND COMMENT
- OTHER:
- FOR ACTION (Trina Brown)
- FOR FILE
- FOR SIGNATURE
- REPLY BY _____ TO AVOID DELAY IN CONSTRUCTION

Remarks:



Alternates
 LFUCG Replacement Senior Citizen Center
 Lexington, KY

3/24/2016
 9:42 AM

Pending Owner Approval

PR-69 Enclose an Exposed Steel Beam at the South Wall of Conference 241 per Proposal Request No. 59

Enclose an Exposed Steel Beam at the South Wall of Conference 241 per Proposal Request No. 59

Enclose an Exposed Steel Beam at the South Wall of Conference 241 - Bennett's Carpets

Quantity Units Hr. Rate Labor U.P. Materials Subcontractor Total

1 ls 700.00 700

0 0 700 700

Cost of In-Place Construction (Labor, Materials and Equipment) = 700
 Marrillia Design and Construction Overhead Percentage = 10.0%
 Overhead - Marrillia Design and Construction = 70
 Marrillia Design and Construction Profit Percentage = 5.0%
 Profit - Marrillia Design and Construction = 35
 General Liability Insurance (Construction) = 1
 Builder's Risk Insurance = 1
 Performance and Payment Bond (Rate of \$9.40 per \$1000 of Cost for \$0 - \$2,500,000) = N/A
 Performance and Payment Bond (Rate of \$8.15 per \$1000 of Cost for \$2,500,000 - \$5,000,000) = N/A
 Performance and Payment Bond (Rate of \$7.20 per \$1000 of Cost for \$5,000,000 and up) = 5
 KY Surcharge on Project Bonds (1.8% of Bond Cost) = 0
 Local Municipality Tax on Project Bonds (5% of Bond Cost) = 0

Total Construction Cost = **813**



ARCHITECTURE INTERIORS

Proposal Request Transmittal

EOP Architects | 201 W Short St Suite 700 Lexington KY 40507 United States

PROJECT	LFUCG Senior Citizens' Center 201333	DATE SENT	3/10/2016
SUBJECT	Soffit at Conference 241	PROPOSAL REQUEST ID	PR-059
TYPE	Proposal Request	TRANSMITTAL ID	00899
PURPOSE	For Review and Response	VIA	Info Exchange

FROM

NAME	COMPANY	EMAIL	PHONE
Harding Dowell	EOP Architects	hdowell@eopa.com	(859) 231-7538

TO

NAME	COMPANY	EMAIL	PHONE
Travis Harris	Marrillia Design and Construction	tharris@marrillia.com	

REMARKS:

Created by: Harding Dowell

Description:

Please provide pricing to enclose an exposed steel beam at the south wall of Conference 241. Finish and paint drywall per spec. Please refer to attached sketch SKA-113.

Thanks,

Harding

Proposal Request Transmittal

DATE: 3/10/2016
ID: 00899

DESCRIPTION OF CONTENTS

QTY	DATED	TITLE	NUMBER	SCALE	SIZE	NOTES
1	3/10/2016	160310_PR- 059_SKA-113.pdf				

COPIES:

Brian Gravitt	(Marrillia Design and Construction)
Jim Martin	(Marrillia Design and Construction)
Josh Marrillia	(Marrillia Design and Construction)
Rob Price	(Marrillia Design and Construction)
Jessica Walker	(LFUCG)
Joyce Thomas	(LFUCG)
Martin Woodford	(LFUCG)

PR-59 Soffit at 241

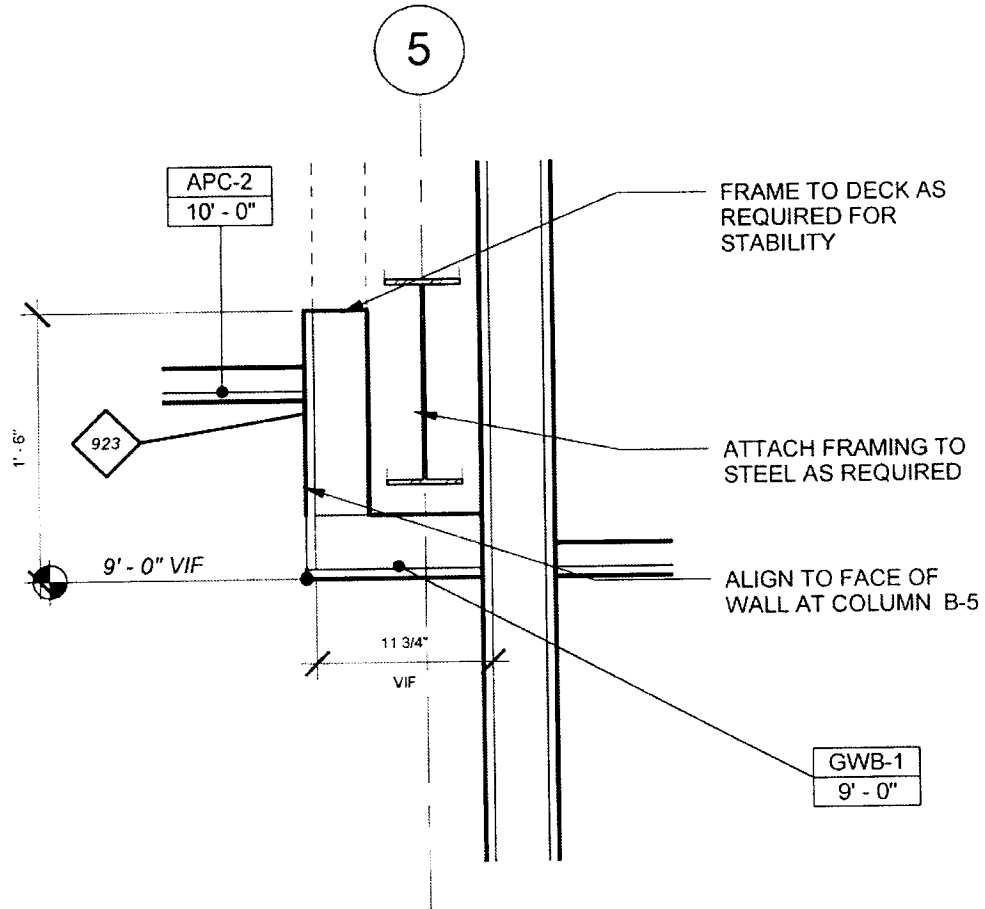

1 CA-SECTION AT CONFERENCE 240
 SKA-113 SCALE: 1" = 1'-0"



LEXINGTON SENIOR CENTER
 195 LIFE LANE
 LEXINGTON, KY 40502

PR-059

Proj. No.	201333	Date	03/10/16
Drawn by	Author	Checked by	Checker

	REVISION	DATE
--	----------	------

SKA-113

1" = 1'-0"



Bennett's Carpets, Inc.
 149 Steve Drive
 Russell Springs, KY 42642
 (270) 866-6930
 Fax (270) 866-6200

QUOTATION • PROPOSAL

TO:	Marrilla	DATE:	02/08/13
ATT:	Travis		
RE:	PR 059		

Description of Work: We hereby submit this estimate for furnishing and installing the following in accordance with plans and specifications including insurance:

Material \$250.00
 Labor \$450.00
 TOTAL 700.00

Total Quotation \$

Note: This quotation will become void if not accepted within 30 days.

We include no demolition unless stipulated. Reggie Roy

Acceptance: _____ Date: ___/___/___

Company/Title: _____

This Quotation/Proposal is to become a part of the contract documents. Payment to be made within 30 days from billing date with retainage held only as a part of original documents and previously agreed. Payment in full within 30 days upon completion and acceptance of this project.



Alternates
 LFUCG Replacement Senior Citizen Center
 Lexington, KY

3/24/2016
 9:58 AM

Pending Owner Approval

PR-70 Additional Waterproofing at Foundations and Add Fluid Applied Barrier at Sheathing per Proposal Request No. 61

Additional Waterproofing at Foundations and Add Fluid Applied Barrier at Sheathing per Proposal Request No. 61

Additional Waterproofing at Foundations and Add Fluid Applied Barrier at Sheathing - JACO Waterproofing

Quantity	Units	Hr.	Rate	Labor	U.P.	Materials	Subcontractor	Total
1	ls					3,000.00	3,000	
				0		0	3,000	3,000

Cost of In-Place Construction (Labor, Materials and Equipment) =	3,000
Marrillia Design and Construction Overhead Percentage =	10.0%
Overhead - Marrillia Design and Construction =	300
Marrillia Design and Construction Profit Percentage =	5.0%
Profit - Marrillia Design and Construction =	150
General Liability Insurance (Construction) =	5
Builder's Risk Insurance =	5
Performance and Payment Bond (Rate of \$9.40 per \$1000 of Cost for \$0 - \$2,500,000) =	N/A
Performance and Payment Bond (Rate of \$8.15 per \$1000 of Cost for \$2,500,000 - \$5,000,000) =	N/A
Performance and Payment Bond (Rate of \$7.20 per \$1000 of Cost for \$5,000,000 and up) =	25
KY Surcharge on Project Bonds (1.8% of Bond Cost) =	0
Local Municipality Tax on Project Bonds (5% of Bond Cost) =	1
Total Construction Cost =	3,486

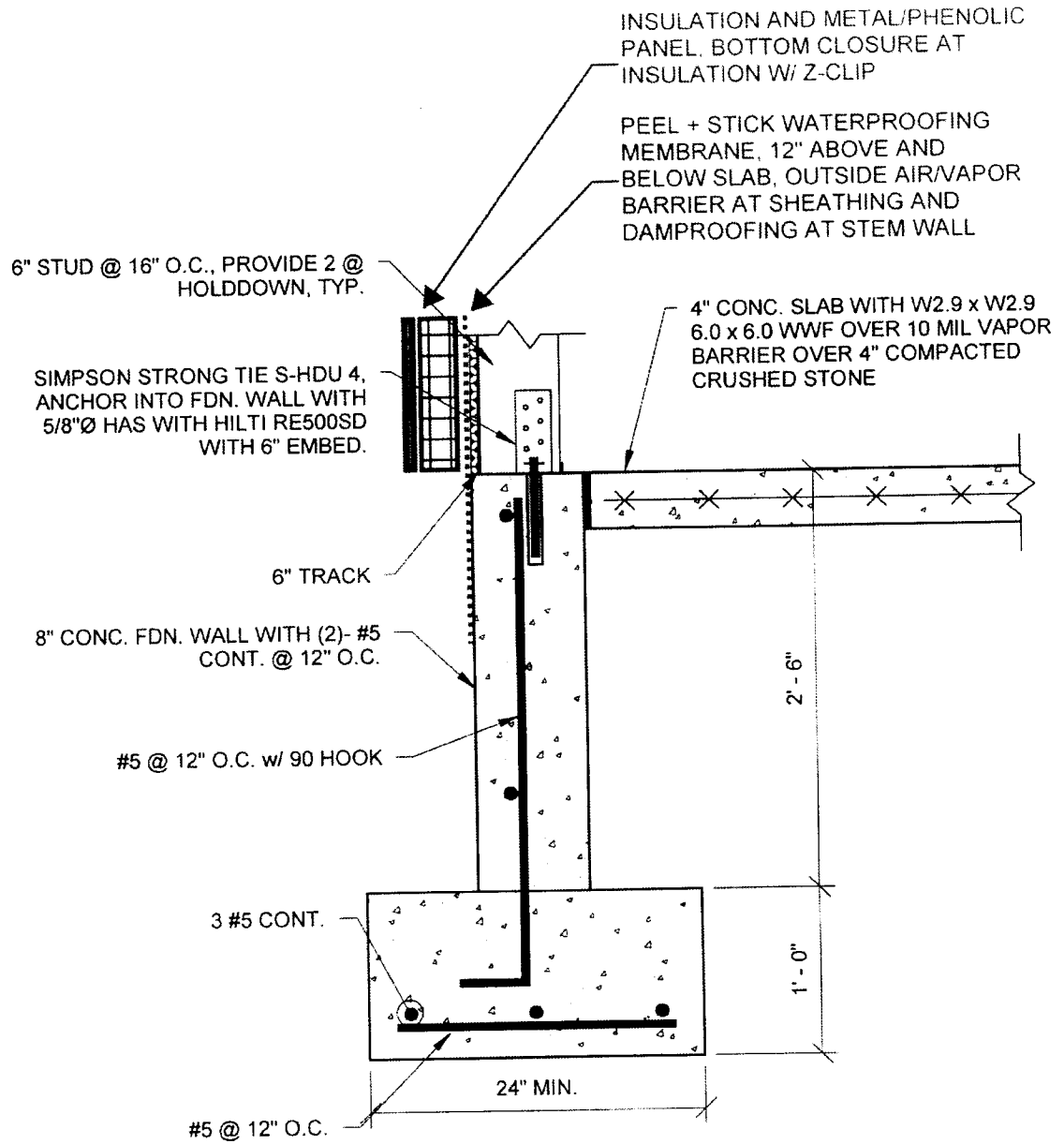

Travis Harris

From: Harding Dowell <hdowell@eopa.com>
Sent: Tuesday, March 22, 2016 4:09 PM
To: Travis Harris
Cc: Jim Martin; Martin Woodford
Subject: Re: LFUCG-Storage Shed Membrane

Hi Travis,

I think this is an acceptable price. The owner will want broken down costs for material and labor. I've forwarded your note as is to Joyce for her concurring approval. Please proceed.

Thanks,

Harding

J Harding Dowell, AIA
EOP Architects
hdowell@eopa.com
859.231.7538

On Mar 22, 2016, at 3:46 PM, Travis Harris <tharris@marrillia.com> wrote:

Harding please send us a formal confirmation that the \$2,500 for the fluid applied and the \$500 for the membrane will be acceptable as we discussed. Lastly, the condition on the south side of the storage shed will still leak since the sidewalk grades are the same as the slab in the shed and confirm how design would like to address this item.

Thanks,

Travis Harris
Site Manager
Marrillia Design and Construction
259 West Short Street, Suite 325
Lexington, Kentucky 40507
Tel 859.685.0414
Fax 859.685.0418
Cell 859.200.9732
Web www.marrillia.com
Email tharris@marrillia.com
<image001.jpg>

Submit Reply