



Lexington-Fayette Urban County Government

Lexington, Kentucky
Horse Capital of the World

Division of Central Purchasing

Date of Issue: January 16, 2020

INVITATION TO BID #15-2020 Luminescent Dissolved Oxygen Analyzer with Digital Controller

Bid Opening Date: February 4, 2020

Bid Opening Time: 2:00 PM

Address: 200 East Main Street, 3rd Floor, Room 338, Lexington, Kentucky 40507

Type of Bid: Price Contract

Pre Bid Meeting: N/A

Pre Bid Time: N/A

Address: N/A

Sealed bids will be received in the office of the Division of Central Purchasing, 200 East Main Street, Lexington, Kentucky, until **2:00 PM**, prevailing local time on **01/04/2020**. Bids must be received by the above-mentioned date and time. Mailed bids should be sent to:

**Division of Central Purchasing
200 East Main Street, Room 338
Lexington, KY 40507, (859) 258-3320**

The Lexington-Fayette Urban County Government assumes no responsibility for bids that are not addressed and delivered as indicated above. **Bids that are not delivered to the Division of Central Purchasing by the stated time and date will be rejected.** All bids must be signed and have the company name and address, bid invitation number, and the name of the bid on the outside of the envelope.

Bids are to include all shipping costs to the point of delivery located at: **VARIOUS LOCATIONS, Lexington, KY**

Bid Security Required: ___ Yes No *Cashier Check, Certified Check, Bid Bond (Personal checks and company checks will not be acceptable).*

Performance Bond Required: ___ Yes No

Bid Specifications Met <input checked="" type="checkbox"/> Check One: Exceptions to Bid Specifications. <i>Exceptions shall be itemized and attached to bid proposal submitted.</i>	Proposed Delivery: <u>30</u> days after acceptance of bid.
Procurement Card Usage —The Lexington-Fayette Urban County Government may be using Procurement Cards to purchase goods and services and also to make payments. Will you accept Procurement Cards? <input checked="" type="checkbox"/> Yes <input type="checkbox"/> No	

Submitted by: Hach Company

Firm Name

5600 Lindbergh Dr

Address

Loveland CO 80538

City, State & Zip

Bid must be signed:
(original signature)

Signature of Authorized Company Representative – Title

Mary Baird

Representative's Name (Typed or printed)

800-227-4224

970-461-3922

Area Code - Phone – Extension

Fax #

bids@hach.com

E-Mail Address

* Per clarification exception letter enclosed

The Affidavit in this bid must be completed before your firm can be considered for award of this contract.

AFFIDAVIT

Comes the Affiant, Mary Baird, and after being first duly sworn under penalty of perjury as follows:

1. His/her name is Mary Baird and he/she is the individual submitting the bid or is the authorized representative of Hach Company the entity submitting the bid (hereinafter referred to as "Bidder")
2. Bidder will pay all taxes and fees, which are owed to the Lexington-Fayette Urban County Government at the time the bid is submitted, prior to award of the contract and will maintain a "current" status in regard to those taxes and fees during the life of the contract.
3. Bidder will obtain a Lexington-Fayette Urban County Government business license, if applicable, prior to award of the contract.
4. Bidder has authorized the Division of Central Purchasing to verify the above-mentioned information with the Division of Revenue and to disclose to the Urban County Council that taxes and/or fees are delinquent or that a business license has not been obtained.
5. Bidder has not knowingly violated any provision of the campaign finance laws of the Commonwealth of Kentucky within the past five (5) years and the award of a contract to the Bidder will not violate any provision of the campaign finance laws of the Commonwealth.
6. Bidder has not knowingly violated any provision of Chapter 25 of the Lexington-Fayette Urban County Government Code of Ordinances, known as "Ethics Act."
7. Bidder acknowledges that "knowingly" for purposes of this Affidavit means, with respect to conduct or to circumstances described by a statute or ordinance defining an offense, that a person is aware or should have been aware that his conduct is of that nature or that the circumstance exists.

Further, Affiant sayeth naught.

Mary Baird

STATE OF Colorado

COUNTY OF Larimer

The foregoing instrument was subscribed, sworn to and acknowledged before me by Mary Baird on this the 29th day of January, 2015 20

My Commission expires: Sept. 20th, 2022

OLIVER WADOSCH
NOTARY PUBLIC
STATE OF COLORADO
NOTARY ID# 20184037415
MY COMMISSION EXPIRES SEPTEMBER 20, 2022

[Signature]

NOTARY PUBLIC, STATE AT LARGE

Please refer to Section II, Bid Conditions, Item "U" prior to completing this form.

I. GREEN PROCUREMENT

A. ENERGY

The Lexington-Fayette Urban County Government is committed to protecting our environment and being fiscally responsible to our citizens.

The Lexington-Fayette Urban County Government mandates the use of Energy Star compliant products if they are available in the marketplace (go to www.Energystar.gov). If these products are available, but not submitted in your pricing, your bid will be rejected as non-compliant.

ENERGY STAR is a government program that offers businesses and consumers energy-efficient solutions, making it easy to save money while protecting the environment for future generations.

Key Benefits

- These products use 25 to 50% less energy
- Reduced energy costs without compromising quality or performance
- Reduced air pollution because fewer fossil fuels are burned
- Significant return on investment
- Extended product life and decreased maintenance

B. GREEN SEAL CERTIFIED PRODUCTS

The Lexington-Fayette Urban County Government is also committed to using other environmentally friendly products that do not negatively impact our environment. Green Seal is a non-profit organization devoted to environmental standard setting, product certification, and public education.

Go to www.GreenSeal.org to find available certified products. These products will have a reduced impact on the environment and on human health. The products to be used must be pre-approved by the LFUCG prior to commencement of any work in any LFUCG facility. If a Green Seal product is not available, the LFUCG must provide a signed waiver to use an alternate product. Please provide information on the Green Seal products being used with your bid response.

C. GREEN COMMUNITY

The Lexington-Fayette Urban County Government (LFUCG) serves as a principal, along with the University of Kentucky and Fayette County Public Schools, in the Bluegrass Partnership for a Green Community. The Purchasing Team component of the Partnership collaborates on economy of scale purchasing that promotes and enhances environmental initiatives. Specifically, when applicable, each principal is interested in obtaining best value products and/or services which promote environment initiatives via solicitations and awards from the other principals.

If your company is the successful bidder on this Invitation For Bid, do you agree to extend the same product/service pricing to the other principals of the Bluegrass Partnership for a Green Community (i.e. University of Kentucky and Fayette County Schools) if requested?

Yes X No

* Please note: Hach is not able to submit or provide certified green product on this invitation to bid. Hach has checked yes above to note that Hach will extend the same products quoted to other principals of the bluegrass Partnership but the product does not meet the green community requirements.

II. Bid Conditions

- A. No bid may be withdrawn for a period of sixty (60) days after the date and time set for opening.
- B. No bid may be altered after the date and time set for opening. In the case of obvious errors, the Division of Central Purchasing may permit the withdrawal of a bid. The decision as to whether a bid may be withdrawn shall be that of the Division of Central Purchasing.
- C. Acceptance of this proposal shall be enactment of an Ordinance by the Urban County Council.
- D. The bidder agrees that the Urban County Government reserves the right to reject any and all bids for either fiscal or technical reasons, and to award each part of the bid separately or all parts to one vendor.
- E. Minor exceptions may not eliminate the bidder. The decision as to whether any exception is minor shall be entirely that of the head of the requisitioning Department or Division and the Director of the Division of Central Purchasing. The Urban County Government may waive technicalities and informalities where such waiver would best serve the interests of the Urban County Government.
- F. Manufacturer's catalogue numbers, trade names, etc., where shown herein are for descriptive purposes and are to guide the bidder in interpreting the standard of quality, design, and performance desired, and shall not be construed to exclude proposals based on furnishing other types of materials and/or services. However, any substitution or departure proposed by the bidder must be clearly noted and described; otherwise, it will be assumed that the bidder intends to supply items specifically mentioned in this Invitation for Bids.
- G. The Urban County Government may require demonstrations of the materials proposed herein prior to acceptance of this proposal.
- H. Bids must be submitted on this form and must be signed by the bidder or his authorized representative. Unsigned bids will not be considered.
- I. Bids must be submitted prior to the date and time indicated for opening. Bids submitted after this time will not be considered.
- J. All bids mailed must be marked on the face of the envelope:

"Bid on #15-2020 Luminescent Dissolved Oxygen Analyzer with Digital Controller"

and addressed to: Division of Central Purchasing
 200 East Main Street, Room 338
 Lexington, Kentucky 40507

The Lexington-Fayette Urban County Government assumes no responsibility for bids that are not addressed and delivered as indicated above. Bids that are not delivered to the Division of Central Purchasing by the stated time and date will be rejected.

- K. Bidder is requested to show both unit prices and lot prices. In the event of error, the unit price shall prevail.
- L. A certified check or Bid Bond in the amount of NA percent of the bid price must be attached hereto. This check must be made payable to the Lexington-Fayette Urban County Government, and will be returned when the material and/or services specified herein have been delivered in accordance with specifications. In the event of failure to perform within the time period set forth in this bid, it is agreed the certified check may be cashed and the funds retained by the Lexington-Fayette Urban County Government as liquidated damages. Checks of unsuccessful bidders will be returned when the bid has been awarded.
- M. The delivery dates specified by bidder may be a factor in the determination of the successful bidder.
- N. Tabulations of bids received may be mailed to bidders. Bidders requesting tabulations must enclose a stamped, self-addressed envelope with the bid.
- O. The Lexington-Fayette Urban County Government is exempt from Kentucky Sales Tax and Federal Excise Tax on materials purchased from this bid invitation. Materials purchased by the bidder for construction projects are not tax exempt and are the sole responsibility of the bidder.

- P. All material furnished hereunder must be in full compliance with OSHA regulations.
- Q. If more than one bid is offered by one party, or by any person or persons representing a party, all such bids shall be rejected.
- R. Signature on the face of this bid by the Bidder or his authorized representative shall be construed as acceptance of and compliance with all terms and conditions contained herein.
- S. The Entity (regardless of whether construction contractor, non-construction contractor or supplier) agrees to provide equal opportunity in employment for all qualified persons, to prohibit discrimination in employment because of race, color, creed, national origin, sex or age, and to promote equal employment through a positive, continuing program from itself and each of its sub-contracting agents. This program of equal employment opportunity shall apply to every aspect of its employment policies and practices.
- T. The Kentucky Equal Employment Opportunity Act of 1978 (KRS 45.560-45.640) requires that any county, city, town, school district, water district, hospital district, or other political subdivision of the state shall include in directly or indirectly publicly funded contracts for supplies, materials, services, or equipment hereinafter entered into the following provisions:

During the performance of this contract, the contractor agrees as follows:

- (1) The contractor will not discriminate against any employee or applicant for employment because of race, color, religion, sex, age or national origin;*
- (2) The contractor will state in all solicitations or advertisements for employees placed by or on behalf of the contractors that all qualified applicants will receive consideration for employment without regard to race, color, religion, sex, age or national origin;*
- (3) The contractor will post notices in conspicuous places, available to employees and applicants for employment, setting forth the provisions of the non-discrimination clauses required by this section; and*
- (4) The contractor will send a notice to each labor union or representative of workers with which he has a collective bargaining agreement or other contract or understanding advising the labor union or workers' representative of the contractor's commitments under the nondiscrimination clauses.*

The Act further provides:

KRS 45.610. Hiring minorities - Information required

- (1) For the length of the contract, each contractor shall hire minorities from other sources within the drawing area, should the union with which he has collective bargaining agreements be unwilling to supply sufficient minorities to satisfy the agreed upon goals and timetable.*
- (2) Each contractor shall, for the length of the contract, furnish such information as required by KRS 45.560 to KRS 45.640 and by such rules, regulations and orders issued pursuant thereto and will permit access to all books and records pertaining to his employment practices and work sites by the contracting agency and the department for purposes of investigation to ascertain compliance with KRS 45.560 to 45.640 and such rules, regulations and orders issued pursuant thereto.*

KRS 45.620. Action against contractor - Hiring of minority contractor or subcontractor

- (1) If any contractor is found by the department to have engaged in an unlawful practice under this chapter during the course of performing under a contract or subcontract covered under KRS 45.560 to 45.640, the department shall so certify to the contracting agency and such certification shall be binding upon the contracting agency unless it is reversed in the course of judicial review.*
- (2) If the contractor is found to have committed an unlawful practice under KRS 45.560 to 45.640, the contracting agency may cancel or terminate the contract, conditioned upon a program for future compliance approved by the contracting agency and the department. The contracting agency may declare such a contractor ineligible to bid on further contracts with that agency until such time as the contractor complies in full with the requirements of KRS 45.560 to 45.640.*

- (3) *The equal employment provisions of KRS 45.560 to 45.640 may be met in part by a contractor by subcontracting to a minority contractor or subcontractor. For the provisions of KRS 45.560 to 45.640, a minority contractor or subcontractor shall mean a business that is owned and controlled by one or more persons disadvantaged by racial or ethnic circumstances.*

KRS 45.630 Termination of existing employee not required, when

Any provision of KRS 45.560 to 45.640 notwithstanding, no contractor shall be required to terminate an existing employee upon proof that that employee was employed prior to the date of the contract.

KRS 45.640 Minimum skills

Nothing in KRS 45.560 to 45.640 shall require a contractor to hire anyone who fails to demonstrate the minimum skills required to perform a particular job.

It is recommended that all of the provisions above quoted to be included as special conditions in each contract. In the case of a contract exceeding \$250,000, the contractor is required to furnish evidence that his work-force in Kentucky is representative of the available work-force in the area from which he draws employees, or to supply an Affirmative Action plan which will achieve such representation during the life of the contract.

- U. Any party, firm or individual submitting a proposal pursuant to this Invitation must be in compliance with the requirements of the Lexington-Fayette Urban County Government regarding taxes and fees before they can be considered for award of this invitation and must maintain a "current" status with regard to those taxes and fees throughout the term of the contract. The contractor must be in compliance with Chapter 13 from the Code of Ordinances of the Lexington-Fayette Urban County Government. The contractor must be in compliance with Ordinance 35-2000 pursuant to contractor registration with the Division of Building Inspection. If applicable, said business must have a Fayette County business license.

Pursuant to KRS 45A.343 and KRS 45A.345, the contractor shall

- (1) *Reveal any final determination of a violation by the contractor within the previous five year period pursuant to KRS Chapters 136 (corporation and utility taxes), 139 (sales and use taxes), 141 (income taxes), 337 (wages and hours), 338 (occupational safety and health of employees), 341 (unemployment and compensation) and 342 (labor and human rights) that apply to the contractor; and*
- (2) *Be in continuous compliance with the above-mentioned KRS provisions that apply to the contractor for the duration of the contract.*

A contractor's failure to reveal the above or to comply with such provisions for the duration of the contract shall be grounds for cancellation of the contract and disqualification of the contractor from eligibility for future contracts for a period of two (2) years.

- V. Vendors who respond to this Invitation have the right to file a notice of contention associated with the bid process or to file a notice of appeal of the recommendation made by the Director of Central Purchasing resulting from this Invitation.

Notice of contention with the bid process must be filed within 3 business days of the bid/proposal opening by (1) sending a written notice, including sufficient documentation to support contention, to the Director of the Division of Central Purchasing or (2) submitting a written request for a meeting with the Director of Central Purchasing to explain his/her contention with the bid process. After consulting with the Commissioner of Finance the Chief Administrative Officer and reviewing the documentation and/or hearing the vendor, the Director of Central Purchasing shall promptly respond in writing findings as to the compliance with bid processes. If, based on this review, a bid process irregularity is deemed to have occurred the Director of Central Purchasing will consult with the Commissioner of Finance, the Chief Administrative Officer and the Department of Law as to the appropriate remedy.

Notice of appeal of a bid recommendation must be filed within 3 business days of the bid recommendation by (1) sending a written notice, including sufficient documentation to support appeal, to the Director, Division of Central Purchasing or (2) submitting a written request for a meeting with the Director of Central Purchasing to explain his appeal. After reviewing the documentation and/or hearing the vendor and consulting with the Commissioner of Finance and the Chief Administrative Officer, the Director of Central Purchasing shall in writing, affirm or withdraw the recommendation.

III. Procurement Contract Bid Conditions

- A. The terms of this agreement shall be for 2 year(s) from the date of acceptance of this contract by the Lexington-Fayette Urban County Government. This agreement may be automatically extended for an additional 2-1 year(s) renewal. This contract may be canceled by either party thirty (30) days after delivery by canceling party of written notice of intent to cancel to the other contracting party.
- B. Price Changes (**Space Checked Applies**)
 - 1. Prices quoted in response to the Invitation shall be firm prices for the first 90 days of the Procurement Contract. After 90 days, prices may be subject to revision and such changes shall be based on general industry changes. Revision may be either increases or decreases and may be requested by either party. There will be no more than one (1) price adjustment per quarter. Requests for price changes shall be received in writing at least twenty (20) days prior to the effective date and are subject to written acceptance before becoming effective. Proof of the validity of a request for revision shall be responsibility of the requesting party. The Lexington-Fayette Urban County Government shall receive the benefit of any decline that the seller shall offer his other accounts.
 - 2. No provision for price change is made herein. Prices are to be firm for the term of this contract.
 - 3. Procurement Level Contract
- C. If any contract item is not available from the vendor, the Lexington-Fayette Urban County Government, at its option, may permit the item to be back-ordered or may procure the item on the open market.
- D. All invoices must bear reference to the Lexington-Fayette Urban County Government Purchasing document numbers which are being billed.
- E. This contract may be canceled by the Lexington-Fayette Urban County Government if it is determined that the Bidder has failed to perform under the terms of this agreement, such cancellation to be effective upon receipt of written notice of cancellation by the Bidder.
- F. No substitutions for articles specified herein may be made without prior approval of the Division of Central Purchasing.

EQUAL OPPORTUNITY AGREEMENT

The Law

- Title VII of the Civil Rights Act of 1964 (amended 1972) states that it is unlawful for an employer to discriminate in employment because of race, color, religion, sex, age (40-70 years) or national origin.
- Executive Order No. 11246 on Nondiscrimination under Federal contract prohibits employment discrimination by contractor and sub-contractor doing business with the Federal Government or recipients of Federal funds. This order was later amended by Executive Order No. 11375 to prohibit discrimination on the basis of sex.
- Section 503 of the Rehabilitation Act of 1973 states:
The Contractor will not discriminate against any employee or applicant for employment because of physical or mental handicap.
- Section 2012 of the Vietnam Era Veterans Readjustment Act of 1973 requires Affirmative Action on behalf of disabled veterans and veterans of the Vietnam Era by contractors having Federal contracts.
- Section 206(A) of Executive Order 12086, Consolidation of Contract Compliance Functions for Equal Employment Opportunity, states:
The Secretary of Labor may investigate the employment practices of any Government contractor or sub-contractor to determine whether or not the contractual provisions specified in Section 202 of this order have been violated.

The Lexington-Fayette Urban County Government practices Equal Opportunity in recruiting, hiring and promoting. It is the Government's intent to affirmatively provide employment opportunities for those individuals who have previously not been allowed to enter into the mainstream of society. Because of its importance to the local Government, this policy carries the full endorsement of the Mayor, Commissioners, Directors and all supervisory personnel. In following this commitment to Equal Employment Opportunity and because the Government is the benefactor of the Federal funds, it is both against the Urban County Government policy and illegal for the Government to let contracts to companies which knowingly or unknowingly practice discrimination in their employment practices. Violation of the above mentioned ordinances may cause a contract to be canceled and the contractors may be declared ineligible for future consideration.

Please sign this statement in the appropriate space acknowledging that you have read and understand the provisions contained herein. Return this document as part of your application packet.

Bidders

I/We agree to comply with the Civil Rights Laws listed above that govern employment rights of minorities, women, veteran status, disability and age.



Signature

Hach Company

Name of Business

GENERAL PROVISIONS OF BID CONTRACT

By signing the below, bidder acknowledges that it understands and agrees with the following provisions related to its bid response and the provision of any goods or services to LFUCG upon selection by LFUCG pursuant to the bid request:

1. Bidder shall comply with all Federal, State & Local regulations concerning this type of service or good.
2. Failure to submit ALL forms and information required by LFUCG may be grounds for disqualification.
3. Addenda: All addenda, if any, must be considered by the bidder in making its response, and such addenda shall be made a part of the requirements of the bid contract. Before submitting a bid response, it is incumbent upon bidder to be informed as to whether any addenda have been issued, and the failure of the bidder to cover any such addenda may result in disqualification of that response.
4. Bid Reservations: LFUCG reserves the right to reject any or all bid responses, to award in whole or part, and to waive minor immaterial defects in proposals. LFUCG may consider any alternative proposal that meets its basic needs.
5. Liability: LFUCG is not responsible for any cost incurred by bidder in the preparation of its response.
6. Changes/Alterations: Bidder may change or withdraw a proposal at any time prior to the opening; however, no oral modifications will be allowed. Only letters, or other formal written requests for modifications or corrections of a previously submitted proposal which is addressed in the same manner as the bid response, and received by LFUCG prior to the scheduled closing time for receipt of bids, will be accepted. The bid response when opened, will then be corrected in accordance with such written request(s), provided that the written request is contained in a sealed envelope which is plainly marked "modifications of bid response".
7. Clarification of Submittal: LFUCG reserves the right to obtain clarification of any point in a bid or to obtain additional information from any bidder.
8. Bribery Clause: By his/her signature on its response, bidder certifies that no employee of his/hers, any affiliate or subcontractor, has bribed or attempted to bribe an officer or employee of the LFUCG.
9. Additional Information: While not necessary, the bidder may include any product brochures, software documentation, sample reports, or other documentation that may assist LFUCG in better understanding and evaluating the bid response. Additional documentation shall not serve as a substitute for other documentation which is required by the LFUCG to be submitted with the bid response.
10. Ambiguity, Conflict or other Errors: If a bidder discovers any ambiguity, conflict, discrepancy, omission or other error in the bid request of LFUCG, it shall immediately notify LFUCG of such error in writing and request modification or clarification of the document if allowable by the LFUCG.
11. Agreement to Bid Terms: In submitting its bid response, the bidder agrees that it has carefully examined the specifications and all provisions relating to LFUCG's bid request, including but not limited to the bid contract. By submission of its bid response, bidder states that it understands the meaning, intent and requirements of LFUCG's bid request and agrees to the same. The successful bidder shall warrant that it is familiar with and understands all provisions herein and shall warrant that it can comply with them. No additional compensation to bidder shall be authorized for services, expenses, or goods reasonably covered under these provisions that the bidder omits from its bid response.
12. Cancellation: LFUCG may unilaterally terminate the bid contract with the selected bidder(s) at any time, with or without cause, by providing at least thirty (30) days advance written notice unless a different advance written notice period is negotiated prior to contract approval. Payment for services or goods received prior to termination shall be made by the LFUCG provided these goods or services were provided in a manner acceptable to the

LFUCG. Payment for those goods and services shall not be unreasonably withheld.

13. **Assignment of Contract:** The selected bidder(s) shall not assign or subcontract any portion of the bid contract with LFUCG without the express written consent of LFUCG. Any purported assignment or subcontract in violation hereof shall be void. It is expressly acknowledged that LFUCG shall never be required or obligated to consent to any request for assignment or subcontract; and further that such refusal to consent can be for any or no reason, fully within the sole discretion of LFUCG.
14. **No Waiver:** No failure or delay by LFUCG in exercising any right, remedy, power or privilege hereunder, nor any single or partial exercise thereof, nor the exercise of any other right, remedy, power or privilege shall operate as a waiver hereof or thereof. No failure or delay by LFUCG in exercising any right, remedy, power or privilege under or in respect of this bid proposal or bid contract shall affect the rights, remedies, powers or privileges of LFUCG hereunder or shall operate as a waiver thereof.
15. **Authority to do Business:** Each bidder must be authorized to do business under the laws of the Commonwealth of Kentucky and must be in good standing and have full legal capacity to provide the goods or services specified in the bid proposal. Each bidder must have all necessary right and lawful authority to submit the bid response and enter into the bid contract for the full term hereof including any necessary corporate or other action authorizing the bidder to submit the bid response and enter into this bid contract. If requested, the bidder will provide LFUCG with a copy of a corporate resolution authorizing this action and/or a letter from an attorney confirming that the proposer is authorized to do business in the Commonwealth of Kentucky. All bid responses must be signed by a duly authorized officer, agent or employee of the bidder.
16. **Governing Law:** This bid request and bid contract shall be governed by and construed in accordance with the laws of the Commonwealth of Kentucky. In the event of any proceedings regarding this matter, the bidder agrees that the venue shall be the Fayette County Circuit Court or the U.S. District Court for the Eastern District of Kentucky, Lexington Division and that the bidder expressly consents to personal jurisdiction and venue in such Court for the limited and sole purpose of proceedings relating to these matters or any rights or obligations arising thereunder.
17. **Ability to Meet Obligations:** Bidder affirmatively states that there are no actions, suits or proceedings of any kind pending against bidder or, to the knowledge of the bidder, threatened against the bidder before or by any court, governmental body or agency or other tribunal or authority which would, if adversely determined, have a materially adverse effect on the authority or ability of bidder to perform its obligations under this bid response or bid contract, or which question the legality, validity or enforceability hereof or thereof.
18. Bidder understands and agrees that its employees, agents, or subcontractors are not employees of LFUCG for any purpose whatsoever. Bidder is an independent contractor at all times related to the bid response or bid contract.
19. If any term or provision of this bid contract shall be found to be illegal or unenforceable, the remainder of the contract shall remain in full force and such term or provision shall be deemed stricken.

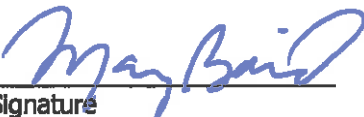
Signature

1/29/2020
Date

WORKFORCE ANALYSIS FORM

Name of Organization: Hach Company

Date: 01 / 29 / 2020

Categories	Total	White		Latino		Black		Other		Total	
		M	F	M	F	M	F	M	F	M	F
Administrators											
Professionals	*Please reference the Hach EEO Reports attached within bid package										
Superintendents											
Supervisors											
Foremen											
Technicians											
Protective Service											
Para-Professionals											
Office/Clerical											
Skilled Craft											
Service/Maintenance											
Total:											

Prepared by: Mary Baird Sr Manager Sales Enablement
Name & Title

**DIRECTOR, DIVISION OF CENTRAL PURCHASING
LEXINGTON-FAYETTE URBAN COUNTY GOVERNMENT
200 EAST MAIN STREET
LEXINGTON, KENTUCKY 40507**

**NOTICE OF REQUIREMENT FOR AFFIRMATIVE ACTION TO ENSURE
EQUAL EMPLOYMENT OPPORTUNITIES AND DBE CONTRACT PARTICIPATION**

The Lexington-Fayette Urban County Government has set a goal that not less than ten percent (10%) of the total value of this contract be subcontracted to MBE/WBE's. The goal for the utilization of certified MBE/WBE's as subcontractors are recommended goals. Contractors who fail to meet such goals will be expected to provide written explanations to the Director of the Division of Central Purchasing of efforts they have made to accomplish the recommended goals and the extent to which they are successful in accomplishing the recommended goals will be a consideration in the procurement process.

For assistance in locating MBE/WBE Subcontractors contact Sherita Miller at 859/258-3320 or by writing the address listed below:

Sherita Miller, Division of Central Purchasing
Lexington-Fayette Urban County Government
200 East Main Street – Room 338
Lexington, Kentucky 40507

Lexington-Fayette Urban County Government
MWDBE PARTICIPATION GOALS

A. GENERAL

- 1) The LFUCG request all potential contractors to make a concerted effort to include Minority-Owned (MBE), Woman-Owned (WBE) and Disadvantaged (DBE) Business Enterprises and Veteran-Owned Businesses as subcontractors or suppliers in their bids.
- 2) Toward that end, the LFUCG has established 10% of total procurement costs as a Goal for participation of Minority-Owned, Woman-Owned and Disadvantaged Businesses on this contract.
- 3) **It is therefore a request of each Bidder to include in its bid, the same goal (10%) for MWDBE participation and other requirements as outlined in this section.**
- 4) The LFUCG has also established a 3% of total procurement costs as a Goal for participation for of Veteran-Owned Businesses.
- 5) **It is therefore a request of each Bidder to include in its bid, the same goal (3%) for Veteran-Owned participation and other requirements as outlined in this section.**

B. PROCEDURES

- 1) The successful bidder will be required to report to the LFUCG, the dollar amounts of all payments submitted to Minority-Owned or Woman-Owned subcontractors and suppliers for work done or materials purchased for this contract. (See Subcontractor Monthly Payment Report)
- 2) Replacement of a Minority-Owned or Woman-Owned subcontractor or supplier listed in the original submittal must be requested in writing and must be accompanied by documentation of Good Faith Efforts to replace the subcontractor / supplier with another MWDBE Firm; this is subject to approval by the LFUCG. (See LFUCG MWDBE Substitution Form)
- 3) For assistance in identifying qualified, certified businesses to solicit for potential contracting opportunities, bidders may contact:
 - a) The Lexington-Fayette Urban County Government, Division of Central Purchasing (859-258-3320)
- 4) The LFUCG will make every effort to notify interested MWDBE and Veteran-Owned subcontractors and suppliers of each Bid Package, including information on the scope of work, the pre-bid meeting time and location, the bid date, and all other pertinent information regarding the project.

C. DEFINITIONS

- 1) A Minority-Owned Business Enterprise (MBE) is defined as a business which is certified as being at least 51% owned and operated by persons of African American, Hispanic, Asian, Pacific Islander, American Indian or Alaskan Native Heritage.
- 2) A Woman-Owned Business Enterprise (WBE) is defined as a business which is certified as being at least 51% owned and operated by one or more Non-Minority Females.
- 3) A Disadvantaged Business (DBE) is defined as a business which is certified as being at least 51% owned and operated by a person(s) that are economically and socially disadvantaged.

- 4) A Veteran-Owned Business is defined as a business which is certified as being at least 51% owned and operated by a veteran and/or a service disabled veteran.
- 5) Good Faith Efforts are efforts that, given all relevant circumstances, a bidder or proposer actively and aggressively seeking to meet the goals, can reasonably be expected to make. In evaluating good faith efforts made toward achieving the goals, whether the bidder or proposer has performed the efforts outlined in the Obligations of Bidder for Good Faith Efforts outlined in this document will be considered, along with any other relevant factors.

D. OBLIGATION OF BIDDER FOR GOOD FAITH EFFORTS

- 1) **The bidder shall make a Good Faith Effort to achieve the Participation Goal for MWDBE subcontractors/suppliers. The failure to meet the goal shall not necessarily be cause for disqualification of the bidder; however, bidders not meeting the goal are required to furnish with their bids written documentation of their Good Faith Efforts to do so.**
- 2) Award of Contract shall be conditioned upon satisfaction of the requirements set forth herein.
- 3) The Form of Proposal includes a section entitled "MWDBE Participation Form". The applicable information must be completed and submitted as outlined below.
- 4) **Failure to submit this information as requested may be cause for rejection of bid.**

E. DOCUMENTATION REQUIRED FOR GOOD FAITH EFFORTS

- 1) Bidders reaching the Goal are required to submit only the MWDBE Participation Form." The form must be fully completed including names and telephone number of participating MWDBE firm(s); type of work to be performed; estimated value of the contract and value expressed as a percentage of the total Lump Sum Bid Price. The form must be signed and dated, and is to be submitted with the bid.
- 2) Bidders not reaching the Goal must submit the "MWDBE Participation Form", the "Quote Summary Form" and a written statement documenting their Good Faith Effort to do so. If bid includes no MWDBE participation, bidder shall enter "None" on the subcontractor / supplier form). In addition, the bidder must submit written proof of their Good Faith Efforts to meet the Participation Goal:
 - a. Advertised opportunities to participate in the contract in at least two (2) publications of general circulation media; trade and professional association publications; small and minority business or trade publications; and publications or trades targeting minority, women and disadvantaged businesses not less than fifteen (15) days prior to the deadline for submission of bids to allow MWDBE firms to participate.
 - b. Included documentation of advertising in the above publications with the bidders good faith efforts package
 - c. Attended LFUCG Central Purchasing Economic Inclusion Outreach event
 - d. Attended pre-bid meetings that were scheduled by LFUCG to inform MWDBEs of subcontracting opportunities

- e. Sponsored Economic Inclusion event to provide networking opportunities for prime contractors and MWDBE firms
- f. Requested a list of MWDBE subcontractors or suppliers from LFUCG Economic Engine and showed evidence of contacting the companies on the list(s).
- g. Contacted organizations that work with MWDBE companies for assistance in finding certified MWDBE firms to work on this project. Those contacted and their responses should be a part of the bidder's good faith efforts documentation.
- h. Sent written notices, by certified mail, email or facsimile, to qualified, certified MWDBEs soliciting their participation in the contract not less than seven (7) days prior to the deadline for submission of bids to allow them to participate effectively.
- i. Followed up initial solicitations by contacting MWDBEs to determine their level of interest.
- j. Provided the interested MWDBE firm with adequate and timely information about the plans, specifications, and requirements of the contract.
- k. Selected portions of the work to be performed by MWDBE firms in order to increase the likelihood of meeting the contract goals. This includes, where appropriate, breaking out contract work items into economically feasible units to facilitate MWDBE participation, even when the prime contractor may otherwise perform these work items with its own workforce.
- l. Negotiated in good faith with interested MWDBE firms not rejecting them as unqualified without sound reasons based on a thorough investigation of their capabilities. Any rejection should be so noted in writing with a description as to why an agreement could not be reached.
- m. Included documentation of quotations received from interested MWDBE firms which were not used due to uncompetitive pricing or were rejected as unacceptable and/or copies of responses from firms indicating that they would not be submitting a bid.
- n. Bidder has to submit sound reasons why the quotations were considered unacceptable. The fact that the bidder has the ability and/or desire to perform the contract work with its own forces will not be considered a sound reason for rejecting a MWDBE quote. Nothing in this provision shall be construed to require the bidder to accept unreasonable quotes in order to satisfy MWDBE goals.
- o. Made an effort to offer assistance to or refer interested MWDBE firms to obtain the necessary equipment, supplies, materials, insurance and/or bonding to satisfy the work requirements of the bid proposal.

- p. Made efforts to expand the search for MWBE firms beyond the usual geographic boundaries.
- q. Other--any other evidence that the bidder submits which may show that the bidder has made reasonable good faith efforts to include MWDBE participation.

Failure to submit any of the documentation requested in this section may be cause for rejection of bid. Bidders may include any other documentation deemed relevant to this requirement. Documentation of Good Faith Efforts are to be submitted with the Bid, if the participation Goal is not met.



MINORITY BUSINESS ENTERPRISE PROGRAM

Sherita Miller, MPA
Minority Business Enterprise Liaison
Division of Central Purchasing
Lexington-Fayette Urban County Government
200 East Main Street
Lexington, KY 40507
smiller@lexingtonky.gov
859-258-3323

OUR MISSION: The mission of the Minority Business Enterprise Program is to facilitate the full participation of minority and women owned businesses in the procurement process and to promote economic inclusion as a business imperative essential to the long term economic viability of Lexington-Fayette Urban County Government.

To that end the city council adopted and implemented resolution 167-91—Disadvantaged Business Enterprise (DBE) 10% Goal Plan in July of 1991. The resolution states in part (a full copy is available in Central Purchasing):

“A Resolution supporting adoption of the administrative plan for a ten percent (10%) Minimum goal for disadvantaged business enterprise participation in Lexington-Fayette Urban County Government construction and professional services contracts; Providing that as part of their bids on LFUCG construction contracts, general Contractors shall make a good faith effort to award at least ten percent (10%) of All subcontracts to disadvantaged business enterprises; providing that divisions of LFUCG shall make a good faith effort to award at least ten percent of their Professional services and other contracts to disadvantaged business enterprises...”

A Disadvantaged Business Enterprise is defined as a business that has been certified as being at least 51% owned, operated and managed by a U.S. Citizen of the following groups:

- African-American
- Hispanic-American
- Asian/Pacific Islander
- Native American/Native Alaskan
- Non-Minority Female
- Economically and Socially Disadvantaged

We have compiled the list below to help you locate certified MBE, WBE and DBE certified businesses. Below is a listing of contacts for LFUCG Certified MWDBEs in Economic Engine (<https://lfucg.economicengine.com>)

Business	Contact	Email Address	Phone
LFUCG	Sherita Miller	smiller@lexingtonky.gov	859-258-3323
Commerce Lexington – Minority Business Development	Tyrone Tyra	tyra@commercelexington.com	859-226-1625
Tri-State Minority Supplier Diversity Council	Sonya Brown	sbrown@tsmsdc.com	502-625-0137
Small Business Development Council	Dee Dee Harbut UK SBDC	dharbut@uky.edu	
	Shiree Mack	smack@uky.edu	
Community Ventures Corporation	James Coles	jcoles@cyckv.org	859-231-0054
KY Department of Transportation	Melvin Bynes	Melvin.bynes@ky.gov	502-564-3601
Ohio River Valley Women’s Business Council (WBENC)	Rea Waldon	rwaldon@gcul.org	513-487-6534
Kentucky MWBE Certification Program	Yvette Smith, Ken Finance Cabin	Yvette.Smith@ky.gov	502-564-8099
National Women Business Owner’s Council (NWBOC)	Janet Harris-Lange	janet@nwbo.org	800-675-5066
Small Business Administration	Robert Coffey	robertcoffey@sba.gov	502-582-5971
LaVoz de Kentucky	Andres Cruz	lavozydeky@yahoo.com	859-621-2106
The Key News Journal	Patrice Muhamma	paatricem@keynewsjournal.com	859-373-9428



LFUCG MWDBE PARTICIPATION FORM

Bid/RFP/Quote Reference # 15-2020

The MWDBE subcontractors listed have agreed to participate on this Bid/RFP/Quote. If any substitution is made or the total value of the work is changed prior to or after the job is in progress, it is understood that those substitutions must be submitted to Central Purchasing for approval immediately.

MWDBE Company, Name, Address, Phone, Email	MBE WBE or DBE	Work to be Performed	Total Dollar Value of the Work	% Value of Total Contract
1. None				
2.				
3.				
4.				

The undersigned company representative submits the above list of MWDBE firms to be used in accomplishing the work contained in this Bid/RFP/Quote. Any misrepresentation may result in the termination of the contract and/or be subject to applicable Federal and State laws concerning false statements and false claims.

Hach Company
Company
1/29/2020
Date

Company Representative
Sr Manager, NA Sales Enablement
Title

* Please reference Hach's attached letter in reference to MWDBE participation.



LFUCG MWDBE SUBSTITUTION FORM

Bid/RFP/Quote Reference # 15-2020

The substituted MWDBE subcontractors listed below have agreed to participate on this Bid/RFP/Quote. These substitutions were made prior to or after the job was in progress. These substitutions were made for reasons stated below and are now being submitted to Central Purchasing for approval. By the authorized signature of a representative of our company, we understand that this information will be entered into our file for this project.

SUBSTITUTED MWDBE Company Name, Address, Phone, Email	MWDBE Formally Contracted/ Name, Address, Phone, Email	Work to Be Performed	Reason for the Substitution	Total Dollar Value of the Work	% Value of Total Contract
1. None					
2.					
3.					
4.					

The undersigned acknowledges that any misrepresentation may result in termination of the contract and/or be subject to applicable Federal and State laws concerning false statements and false claims.

Hach Company
Company
1/29/2020
Date

Company Representative
Sr Manager, NA Sales Enablement
Title

*Please reference Hach's attached letter in reference to MWDBE participation.



MWDBE QUOTE SUMMARY FORM

Bid/RFP/Quote Reference # 15-2020

The undersigned acknowledges that the minority subcontractors listed on this form did submit a quote to participate on this project.

Company Name Hach Company	Contact Person Lance Williams
Address/Phone/Email 5600 Lindbergh Dr Loveland CO 80538 800-227-4224 bids@hach.com	Bid Package / Bid Date

MWDBE Company Address	Contact Person	Contact Information (work phone, Email, cell)	Date Contacted	Services to be performed	Method of Communication (email, phone meeting, ad, event etc)	Total dollars \$\$ Do Not Leave Blank (Attach Documentation)	MBE * AA HA AS NA Female	Veteran
None								

(MBE designation / AA=African American / HA= Hispanic American/AS = Asian American/Pacific Islander/ NA= Native American)

The undersigned acknowledges that all information is accurate. Any misrepresentation may result in termination of the contract and/or be subject to applicable Federal and State laws concerning false statements and claims.

Hach Company

Company

1/29/2020

Date

Company Representative

Sr Manager, NA Sales Enablement

Title

*Please reference Hach's attached letter in reference to MWDBE participation



LFUCG SUBCONTRACTOR MONTHLY PAYMENT REPORT

The LFUCG has a 10% goal plan adopted by city council to increase the participation of minority and women owned businesses in the procurement process. In order to measure that goal LFUCG will track spending with MWDBE vendors on a monthly basis. By the signature below of an authorized company representative, you certify that the information is correct, and that each of the representations set forth below is true. Any misrepresentation may result in termination of the contract and/or prosecution under applicable Federal and State laws concerning false statements and false claims. Please submit this form monthly to the Division of Central Purchasing/ 200 East Main Street / Room 338 / Lexington, KY 40507.

Bid/RFP/Quote # 15-2020
 Total Contract Amount Awarded to Prime Contractor for this Project N/A

Project Name/ Contract #	Work Period/ From: <u>N/A</u> To:
Company Name:	Address:
Federal Tax ID:	Contact Person:

Subcontractor Vendor ID (name, address, phone, email)	Description of Work	Total Subcontract Amount	% of Total Contract Awarded to Prime for this Project	Total Amount Paid for this Period	Purchase Order number for subcontractor work (please attach PO)	Scheduled Project Start Date	Scheduled Project End Date
N/A							

By the signature below of an authorized company representative, you certify that the information is correct, and that each of the representations set forth below is true. Any misrepresentations may result in the termination of the contract and/or prosecution under applicable Federal and State laws concerning false statements and false claims.

N/A
 Company

N/A
 Company Representative

 Date

N/A
 Title

LFUCG STATEMENT OF GOOD FAITH EFFORTS
Bid/RFP/Quote # 15-2020

By the signature below of an authorized company representative, we certify that we have utilized the following Good Faith Efforts to obtain the maximum participation by MWDBE business enterprises on the project and can supply the appropriate documentation.

- _____ Advertised opportunities to participate in the contract in at least two (2) publications of general circulation media; trade and professional association publications; small and minority business or trade publications; and publications or trades targeting minority, women and disadvantaged businesses not less than fifteen (15) days prior to the deadline for submission of bids to allow MWDBE firms to participate.
- _____ Included documentation of advertising in the above publications with the bidders good faith efforts package
- _____ Attended LFUCG Central Purchasing Economic Inclusion Outreach event
- _____ Attended pre-bid meetings that were scheduled by LFUCG to inform MWDBEs of subcontracting opportunities
- _____ Sponsored Economic Inclusion event to provide networking opportunities for prime contractors and MWDBE firms
- _____ Requested a list of MWDBE subcontractors or suppliers from LFUCG Economic Engine and showed evidence of contacting the companies on the list(s).
- _____ Contacted organizations that work with MWDBE companies for assistance in finding certified MWDBE firms to work on this project. Those contacted and their responses should be a part of the bidder's good faith efforts documentation.
- _____ Sent written notices, by certified mail, email or facsimile, to qualified, certified MWDBEs soliciting their participation in the contract not less than seven (7) days prior to the deadline for submission of bids to allow them to participate effectively.
- _____ Followed up initial solicitations by contacting MWDBEs to determine their level of interest.
- _____ Provided the interested MWDBE firm with adequate and timely information about the plans, specifications, and requirements of the contract.
- _____ Selected portions of the work to be performed by MWDBE firms in order to increase the likelihood of meeting the contract goals. This includes, where appropriate, breaking out contract work items into economically feasible units to facilitate MWDBE participation, even when the prime contractor may otherwise perform these work items with its own workforce
- _____ Negotiated in good faith with interested MWDBE firms not rejecting them as unqualified without sound reasons based on a thorough investigation of their capabilities. Any rejection should be so noted in writing with a description as to why an agreement could not be reached.

- _____ Included documentation of quotations received from interested MWDBE firms which were not used due to uncompetitive pricing or were rejected as unacceptable and/or copies of responses from firms indicating that they would not be submitting a bid.
- _____ Bidder has to submit sound reasons why the quotations were considered unacceptable. The fact that the bidder has the ability and/or desire to perform the contract work with its own forces will not be considered a sound reason for rejecting a MWDBE quote. Nothing in this provision shall be construed to require the bidder to accept unreasonable quotes in order to satisfy MWDBE goals.
- _____ Made an effort to offer assistance to or refer interested MWDBE firms to obtain the necessary equipment, supplies, materials, insurance and/or bonding to satisfy the work requirements of the bid proposal
- _____ Made efforts to expand the search for MWDBE firms beyond the usual geographic boundaries.
- _____ Other - any other evidence that the bidder submits which may show that the bidder has made reasonable good faith efforts to include MWDBE participation.

Failure to submit any of the documentation requested in this section may be cause for rejection of bid. Bidders may include any other documentation deemed relevant to this requirement. Documentation of Good Faith Efforts are to be submitted with the Bid, if the participation Goal is not met.

The undersigned acknowledges that all information is accurate. Any misrepresentations may result in termination of the contract and/or be subject to applicable Federal and State laws concerning false statements and claims.

Hach Company
Company

Company Representative

1/29/22020
Date

SR Manager, NA Sales Enablement
Title

* Please reference Hach's attached letter in reference to MWDBE participation

**UNIT PRICE CONTRACT
 BID SPECIFICATIONS
 FOR
 LUMINESCENT DISSOLVED OXYGEN ANALYZER
 WITH DIGITAL CONTROLLER FOR DIGITAL SENSORS**

PART 1 GENERAL

1.1 SCOPE

The successful bidder will provide a two (2) year unit price contract, with two (2) one (1) year renewal(s), for luminescent dissolved oxygen (LDO) analyzers with the digital controllers for digital sensors and all related wire and mounting assemblies, that is at a minimum, equal to the HACH LDO Probe and sc200 Controller.

The Lexington-Fayette Urban County Government anticipates equipment purchased from this contract will be for the purpose of new installations due to process change(s) and/or replacement of existing equipment as necessary due to end of serviceable life expectancy and/or other routine service and/or maintenance needs. There is no guarantee on the quantity of individual specific components that will be purchased during the duration of the unit price contract.

1.2 SUBMITTALS

- A. Manufacturers data and specifications of the Luminescent Dissolved Oxygen Sensor and Controller.
- B. Copy of the manufacturer's equipment warranty detailing the duration of the warranty and all limitations to the warranty.
- D. A copy of this specification with each paragraph check marked to show specification compliance or marked to show deviations. All exceptions should be clearly noted.

1.3 MEASUREMENT PROCEDURES

- A. The method of measurement will be with a probe using luminescent sensor technology.

Specification Compliant	
Yes	No
x	

1.4 ALTERNATES

- A. Other methods of dissolved oxygen measurement, such as probes that use a selective membrane or those that use electrolytes, are not acceptable.

1.5 SYSTEM DESCRIPTION

- A. Performance Requirements
 - 1. Measurement range: 0.00 to 20 mg/L
 - 2. Accuracy: ± 0.2 percent of span
 - 3. Resolution: 0.01 mg/L

Specification Compliant	
Yes	No
x	

4. Repeatability: ± 0.1 ppm
5. Sensitivity: ± 0.05 percent of span
6. Response time: 90 percent in less than 40 seconds and 95 percent in less than 60 seconds at 20°C

1.6 CERTIFICATIONS

- A. EMI/RFI conformance exceeds U.S. and meets European standards for conducted and radiated emissions and immunity.
- B. Certified CE compliant for applications as specified by EN 50081-1 for emissions and EN 50082-2 for immunity.
- C. General Purpose: CSA/CSANRTL and FM
- D. Meet EPA CFR 136

Specification Compliant	
Yes	No
x	

1.7 ENVIRONMENTAL REQUIREMENTS

- A. Operational Criteria
 1. Operating temperature:
 - a. Probe: 0 to 50 degrees C
 - b. Controller: -20 to 60 degrees C
 2. Relative humidity: 95 percent, non-condensing
 3. Immersion depth: 15 meters, maximum
 4. Immersion pressure: 1050 kPa, maximum
 5. Distance, analyzer to sensor: 1000 meters, maximum

Specification Compliant	
Yes	No
x	

1.7 WARRANTY

- A. The probe includes a three-year warranty from the date of shipment.
- B. The sensor cap includes a one-year warranty from the date of shipment.
- C. The controller includes a one-year warranty from the date of shipment.

Specification Compliant	
Yes	No
x	

1.8 MAINTENANCE SERVICE

- A. Scheduled maintenance:
 1. Sensor cleaning: 90 days or depending on conditions
 2. Sensor and sensor cap inspection: 90 days
 3. Sensor cap replacement: annually
 4. Calibration: per regulatory agency schedule
- B. Unscheduled maintenance
 1. Replace fuse
 2. Clean instrument enclosure

Specification Compliant	
Yes	No
x	

PART 2 PRODUCTS

2.1 MANUFACTURERS

The recommended LDO analyzer and controller must at a minimum, equal the HACH LDO Probe and sc200 Controller.

Specification Compliant	
Yes	No
x	

2.2 MANUFACTURED UNIT

- A. The LDO probe consists of continuous-reading probe, replaceable sensor cap, and 10-meter integral cable.
- B. The sc200 controller is microprocessor-based and is housed in a NEMA 4X enclosure, rated IP66.

Specification Compliant	
Yes	No
x	

2.3 EQUIPMENT

- A. The sensor is made of polybutyl methacrolate.
- B. The probe is made of foamed Noryl® and 316 stainless steel.
- C. The probe is entirely corrosion-resistant and fully immersible.
- D. The probe does not require sample conditioning or electrolyte solutions.
- E. The probe interface to the controller is MODBUS®.
- F. The operation of the probe is not affected by H₂S, pH, K⁺¹, Na⁺¹, Mg⁺², Ca⁺², NH₄⁺¹, Al⁺³, Pb⁺², Cd⁺², Zn⁺², Cr (total), Fe⁺², Fe⁺³, Mn⁺², Cu⁺², Mi⁺², Co⁺², CN⁻¹, NO₃⁻¹, SO₄⁻², S⁻², PO₄⁺³, Cl⁻¹, anion active tensides, crude oils, or Cl₂⁻¹.
- G. The sc200 operates using 100 or 230 volt, 50/60 Hz power.
- H. The sc200 displays dissolved oxygen measurement, temperature, and menu-driven operation system.
- I. The sc200 is equipped with temperature compensation.
- J. The sc200 can support up to two probes.
- K. The sc200 has a data logger with RS485 capability.
- L. Calibration methods:
1. Sample calibration: Sample is compared to a standard instrument or the Winkler Titration method.
 2. Air calibration: One point, 100 percent water-saturated air.
- M. Four (4) SPDT relays, user-configurable contacts rated 100 to 230 Vac, 5 Amp resistive maximum.
- N. Two analog 4-20 mA outputs and/or optional selectable digital I/O, maximum impedance 500 Ohms.
- O. Alarms
1. Low alarm point
 2. Low alarm point deadband
 3. High alarm point
 4. High alarm point deadband
 5. Off delay
 6. On delay
- P. Controls
1. High/low phasing

Specification Compliant	
Yes	No
x	

- 2. Setpoint
- 3. Deadband
- 4. Overfeed timer
- 5. Off delay
- 6. On delay
- Q. Communication
 - 1. RS-485 (MODBUS): Advanced communications/networking with PLC or SCADA system directly from analyzer.
- R. All user settings of the sc200 are retained indefinitely in memory (non-volatile, EEPROM).

2.4 COMPONENTS

A. Standard equipment:

- 1. Analyzer
- 2. Probe
- 3. Manual

Specification Compliant	
Yes	No
X	

B. Dimensions

- 1. Probe
 - a. Diameter: 60 mm (2.4 in.)
 - b. Length: 290 mm (11.5 in.)
- 2. Controller
 - a. 1/2 DIN
 - b. Height: 144 mm (5.7 in.)
 - c. Width: 144 mm (5.7 in.)
 - d. Depth: 181 mm (5.9 in.)

C. Weight

- 1. Probe: 3 pounds, 2 ounces (1.4 kg)
- 2. Controller: 3.75 pounds (1.6 kg)

D. Sensor cable: 32 foot, integral

2.5 ACCESSORIES

- A. Replacement sensor
- B. Sun shield
- C. Junction box for cable extension
- D. Extension cable
- E. Pole mount kit
- F. Ball float mount kit
- G. Air blast cleaning system

Specification Compliant	
Yes	No
X	

2.6 PRODUCT DATA

- A. The following information shall be provided:
 - 1. 2 copies of applicable operation and maintenance information
 - 2. Copy of warranty stated in the bid.

Specification Compliant	
Yes	No
X	

PART 3 TRAINING

3.1 TRAINING

At the discretion of Division of Water Quality a minimum one (1) day of field service may be necessary. If deemed necessary the field service representative may be required to be on site to supervise installation of one of the LDO sensors, educate personnel in programming the analyzer and to start up the equipment.

Please write in the unit price bid for the item listed below:

<u>ITEM DESCRIPTION</u>	<u>LFUCG Commodity Number</u>	<u>Manufacturer/Model</u> (Price for one Model Type per specifications)	<u>UNIT PRICE</u>
(1) day of field service training by service representative		Hach part #59P with travel	\$2545.00

PART 4 GENERAL

4.1 Section includes:

- A. A modular single or dual channel controller that works with digital sensors and analog sensor modules.

Specification Compliant	
Yes	No
X	

4.2 Measurement Procedures

- A. Microprocessor-based sensor controller.
- B. Change digital sensors connected to the controller by unplugging and plugging sensors as necessary.
- C. Change analog sensors modules connected to the controller by unplugging and plugging analog sensor modules as necessary.

Specification Compliant	
Yes	No
X	

4.3 Alternates

- A. Parameter-specific controllers that **do not allow** changing parameter configurations in the field are **unacceptable**.

Specification Compliant	
Yes	No
X	

4.4 System Description

- A. Performance Requirements
- B. DO sensor module
- C. Measurement range:
 - 1. 0 to 20 ppm
 - 2. 200% saturation
- D. Repeatability: $\pm 0.05\%$ of range
- E. Response time: 0.5 s
- F. Temperature range: 0 to 50 °C
 - 1. 20 to 200,000 $\mu\text{S}/\text{cm}$, K=1: $\pm 1\%$ of reading
- G. Response time: 0.5 s
- H. Temperature range: -20 to 50 °C

Specification Compliant	
Yes	No
X	

4.5 Certifications

- A. EMC: Certified CE compliant for conducted and radiated emissions (EN 50081-2) and immunity (EN 61000-6-2).
- B. General purpose: UL through ETL.

Specification Compliant	
Yes	No
X	

4.6 Environmental Requirements

- A. Operational Criteria
 - 1. Temperature: -4.0 to 140.0 °F (-20.0 to 60.0 °C)
 - 2. Relative humidity: 0 to 95%, non-condensing

Specification Compliant	
Yes	No
X	

4.7 Warranty

- A. Warranted for two years from date of shipment from manufacturers defects.

Specification Compliant	
Yes	No
X	

4.8 Maintenance Service

- A. Clean controller keypad
- B. Calibrate mA output signals

Specification Compliant	
Yes	No
X	

PART 5 PRODUCTS

5.1 Manufacturer

- A. Hach Company, Loveland, CO
- B. Hach model sc200 Digital Controller or equal

Specification Compliant	
Yes	No
X	

5.2 Manufactured Unit

- A. The controller provides connections for up to 29 Hach digital and analog sensor families for 15 different parameters.
- B. The controller is available with the following power requirements:
 - 1. AC powered: 100 to 240 Vac \pm 10%, 50/60 Hz; 15 W with 7 W sensor/network card load, 37 W with 25 W sensor/network card load.
- D. The controller uses a menu-driven operation system.
- E. The controller display is graphic dot matrix LCD with LED backlighting.
- F. The controller is equipped with a real-time clock.
- G. The controller is equipped with two security levels.
- H. Four electromechanical, UL rated, SPDT relays (Form C) are provided for user-configurable contacts rated 100 to 230 Vac, 5 Amp at 30 Vdc resistive maximum.
 - a. The following can be programmed:
 - 1. Alarm
 - 2. Warning
 - 3. Timer/scheduled cleaning
 - 4. Feeder control
 - 5. Event control
 - 6. Pulse width modulation
 - 7. Frequency modulation
 - b. The following can be assigned:
 - 1. Primary value measurement I
 - 2. Secondary value measurement I
 - 3. 3rd value measurement I
 - 4. 4th value measurement I
 - 5. Primary value Measurement II
 - 6. Secondary value measurement II
 - 7. 3rd value measurement II
 - 8. 4th value measurement II
 - 9. Real time clock
 - 10. Calculated values
- I. Two analog 0/4-20 mA outputs are provided with a maximum impedance of 500 ohms.
 - a. The following can be programmed:
 - 1. Alarms:
 - i. Low alarm point
 - ii. Low alarm point deadband
 - iii. High alarm point
 - iv. High alarm point deadband
 - v. Off delay
 - vi. On delay

Specification Compliant	
Yes	No
X	

- 2. Controls:
 - i. Linear
 - i. Bi-linear
 - ii. Logarithmic
 - iii. PID
- b. The following can be assigned:
 - 1. Primary value measurement I
 - 2. Secondary value measurement I
 - 3. 3rd value measurement I
 - 4. 4th value measurement I
 - 5. Primary value measurement II
 - 6. Secondary value measurement II
 - 7. 3rd value measurement II
 - 8. 4th value measurement II
 - 9. Calculated values
- J. All user settings of the controller are retained for 10 years in flash memory.
- K. The controller is equipped with a system check for:
 - 1. Power up test (monitoring and shutdown)
 - 2. Total power draw
 - 3. Memory devices
 - 4. Temperature mother board

5.3 Equipment

A. Materials

- 1. Housing: polycarbonate, aluminum (powder coated), and stainless steel
- 2. Rating: NEMA 4X enclosure, rated IP66

B. Conduit openings: 0.5 in. NPT

Specification Compliant	
Yes	No
X	

5.4 Components

A. Standard equipment

- 1. Controller
- 2. Mounting hardware for wall, pipe, and panel mounting

B. Dimensions: 1/2 DIN (144 x 144 x 180 mm (5.7 x 5.7 x 7.1 in.))

C. Weight: 1.6 kg (3.5 lbs.)

Specification Compliant	
Yes	No
X	

5.5 Accessories

- A. Weather protection shield
- B. Sun screen
- C. RS-485 MODBUS module
- D. PROFIBUS DP module
- E. Additional mA output module
- F. 4-20 Ma input module
- G. SD card reader (USB) for connection to PC
- H. 4 GB SD Card
- I. DO Module

Specification Compliant	
Yes	No
X	

PART 6 EXECUTION

6.1 Preparation

- A. The sensor may need to be installed with additional accessories depending on its application.
1. Mount on rail, panel, pipe, or wall.
 2. Sensor to analyzer distance: 300 m (985 ft.)

Specification Compliant	
Yes	No
X	

6.2 Installation

- A. DWQ personnel will install the analyzer in strict accordance with the manufacturer's instructions and recommendation.
- B. Manufacturer's representative will include a half-day of start-up service by a factory-trained technician, if requested.
1. DWQ staff will schedule a date and time for start-up.
 2. DWQ may require the following people to be present during the start-up procedure.
 3. Hach Company factory trained representative

Specification Compliant	
Yes	No
X	

Please write in the unit price bid for the Item listed below:

ITEM DESCRIPTION	LFUCG Commodity Number	Manufacturer/Model (Price for one Model Type per Specifications)	UNIT PRICE
Controller for Measuring Dissolved Oxygen 0-20 ppm Hach part # LXV404.99.00552		Hach part # LXV404.99.00552	\$2219.00
Weather Sun Shield for Controller Hach part # 9220600		Hach part # 9220600	\$233.00
UV Protection Screen for Controller Hach part # 8809200		Hach part # 8809200	\$171.00
SD Card Reader (USB) for connection to PC Hach part # 9218200		Hach part # 9218200	\$47.25
4 GB SD Card Hach part # 9218100		Hach part # 9218100	\$62.75
D.O. Module for controller Hach part # 9012900		Hach part # 9012900	\$432.00
4-20 mA Input Module Hach part # 9012800		Hach part # 9012800	\$432.00

Modbus Network Module Hach part # 9013200		Hach part # 9013200	\$601.00
Profibus Network Module Hach part # 9173900		Hach part # 9173900	\$619.00
4-20 mA output Module Hach part # 9334600		Hach part # 9334600	\$379.00
Power Cord with strain relief for controller Hach part # 9202900		Hach part # 9202900	\$66.45
LDO probe with 32.8 ft integral cable Hach part # 5790000		Hach part # 5790000 is an obsolete product and is no longer available	N/A
Handrail Pole Mount kit for the LDO probes Hach part # 5794400		Hach part # 5794400	\$524.00
Ball Float Mount Kit for the LDO Probes Hach part # 5794300		Hach part # 5794300	\$719.00
Digital Termination box for cable extensions Hach part # 5867000		Hach part # 5867000	\$201.00
25 foot (7.7 meters) extension cable Hach part # 5796000		Hach part # 5796000	\$204.00
50 foot (15 meters) extension cable Hach part # 5796100		Hach part # 5796100	\$303.00
100 foot (31 meters) extension cable Hach part # 5796200		Hach part # 5796200	\$401.00
Air Blast Cleaning System Hach part # 6860001		Hach part # 6860001	\$2242.00
LDO Replacement sensor cap Hach part # 5791100		Hach part # 5791100	\$305.00
LDO Model 2 Probe Hach part #9020000		Hach part # 9020000	\$2131.00
LDO Model 2 Sensor Cap Hach part #902110		Hach part # 9021100	\$233.00
LDO Model 2 Pole Mount Kit Hach part #9253000		Hach part # 9253000	\$537.00
LDO Model 2 Ball Float Mount Hach part # 9253100		Hach part # 9253100	\$737.00
LDO Model 2 Union Mount Hach part #9253100		Hach part # 9253100	\$737.00

LDO Model 2 1" NPT flow cell Hach part #7300800		Hach part # 7300800	\$537.00
Half day of on-site start up and training on an as needed basis		Hach part # 57P- half day of service including start up travel	\$1397.00
Full day of on-site start up and training on an as needed basis			\$2545.00

*Please reference the enclosed Hach quotation # 100357218v2 for additional information.

*Please reference the enclosed Hach exceptions. Hach meets all the specifications but taking exception to freight terms, Hach pre-pay and add freight charges will apply reference enclosed freight schedule. Hach is also submitting with the term of updated pricing at time of the one year renewal options.

Question should be directed through lonwave or to brianm@lexingtonky.gov.

Date: 1/29/2020

Lexington Fayette Urban County Government
Division of Central Purchasing
200 East Main St, Room 338
Lexington KY 40507

Bid Reference: #15-2020 Luminescent Dissolved Oxygen Analyzer with Digital Controller
Exception to terms within bidding contract

Dear Purchasing Division:

Hach Company appreciates the opportunity to conduct business with you. We have carefully reviewed all of the documents contained in the Bid # 15-2020. Based on our review, and in order to help enable Hach to provide Lexington with the best and most cost effective products and services we can offer, we respectfully request that you accommodate the following revisions to the General Provisions, as noted below:

Freight terms: Exception is taken to free freight under the contract. Hach standard per-pay and add freight charges will apply. Please reference the enclosed freight schedule attached with Hach quotation # 100357218v2

Renewal terms: Hach is submitting with terms in which updated pricing upon the commencement of the two one- year renewal options will apply.

We at Hach Company look forward to completing your order and offering you the quality products and services we are proud to deliver to our customers.

*Please note that Hach Company is not able to proceed until a signed acceptance is received.

ACCEPTED BY:

Lexington Fayette Representative

By: (Printed Name)

Signed

Title

Date



City of Lexington
Division of Central Purchasing
200 East Main Street Room 338
Lexington KY 40507

1/29/2020

Ref: Bid # 15-2020 Luminescent Dissolved Oxygen Analyzer with Digital Controller
MWDBE participation

Hach is a Corporation that utilizes numerous vendors in which Hach has taken good faith efforts to include MWDBE participation.

Due to the requirements of the RFQ, all work performed must be done through qualified factory employed personnel. Hach Business Inclusion and Development utilizes active MWDBE suppliers that is specific to our overall manufacturing for product, but not only specified or allocated to Bid #15-2020

Hach has a diverse and inclusive workforce. The CEO for our parent company, Danaher Corporation, has personally joined 250 other CEO's by signing the "CEO Action for Diversity & Inclusion" pledge, a public commitment to advance diversity and inclusion throughout Danaher. Forbes has named Danaher among the best employers for Diversity in 2019. We're working hard to build an organization that celebrates difference, learns from diverse perspectives, and values inclusion as a core foundation of our company culture. In good faith, we also strive to utilize MWBE suppliers.

Hach Company has and will continue to take the following steps to demonstrate good faith efforts in achieving small business subcontracting goals.

- Further implement Hach Company's Corporate Policy for Small Business Supplier Program and trained Strategic Sourcing Personnel on small business policy.
- Use the Mountain Plains Minority Development Council to assist Hach in locating new qualified suppliers.
- Post Hach's small business program to our external (public) website to allow targeted small business suppliers to easily contact us.
- Identify and develop multiple new potential small business suppliers in FY20 to meet or expand the number of new sources developed in prior years.
- Perform an annual review of actual purchases from each category of small business to determine if goals are being met.

EQUAL EMPLOYMENT OPPORTUNITY POLICY

It is the policy of Hach Company not to discriminate against any employee or applicant for employment because of race, sex, color, age, physical or mental disability, religion, national origin, status as an individual with a disability or a protected veteran, (i.e., disabled veteran, Armed Forces service medal veteran, recently separated veteran, or other veteran who served during a war, or in a campaign or expedition for which a campaign badge has been authorized), or any other personal characteristic protected by law. It is also the policy of the Company to take affirmative action to employ and to advance in employment, all persons regardless of legally protected personal characteristics, and to base all employment decisions only on valid job requirements. This policy shall apply to all employment actions, including but not limited to recruitment, hiring, upgrading, promotion, transfer, demotion, layoff, recall, termination, rates of pay or other forms of compensation and selection for training, including apprenticeship, at all levels of employment.

Employees and applicants shall not be subjected to harassment, intimidation, threats, coercion or discrimination because they have engaged in or may engage in any of the following activities: filing a complaint; assisting or participating in an investigation, compliance evaluation, hearing or any other activity related to the administration of the affirmative action provisions of Executive Order 11246, the Rehabilitation Act, the Vietnam Era Veterans' Readjustment Assistance Act (VEVRAA) or any other Federal, state or local law requiring equal opportunity for women, minorities, disabled individuals, or protected veterans; opposing any act or practice made unlawful by Executive 11246, the Rehabilitation Act, VEVRAA or their implementing regulations, or any other Federal, state or local law requiring equal opportunity for women, minorities, disabled individuals, or protected veterans; or exercising any other right protected by Executive Order 11246, the Rehabilitation Act, VEVRAA, or their implementing regulations.

Hach is committed to the principles of Affirmative Action and Equal Employment Opportunity. Anyone desiring additional information relating to Affirmative Action and Equal Opportunity should contact Karen Code, Senior Recruiter for Hach.

12.18.15

Date
PERMANENT POSTING



Director, Human Resources

CO= 1027831
 U= 5017971

EQUAL EMPLOYMENT OPPORTUNITY
 2018 EMPLOYER INFORMATION REPORT
 INDIVIDUAL ESTABLISHMENT REPORT - TYPE 4

SECTION B - COMPANY IDENTIFICATION

1. DANAHER CORPORATION
 2200 PENNSYLVANIA AVE STE 800W
 WASHINGTON, DC 20037

2a. HACH COMPANY
 6800 LINDBERGH DRIVE
 LOVELAND, CO 80538
 LARIMER COUNTY
 c. Y

SECTION C - TEST FOR FILING REQUIREMENT

1-Y 2-Y 3-Y DUNS NO.:005286679 EIN :420704420

SECTION E - ESTABLISHMENT INFORMATION

NAICS: 334518 Analytical Laboratory
 Instrument Manufacturing

SECTION D - EMPLOYMENT DATA

JOB CATEGORIES	HISPANIC OR LATINO		NOT-HISPANIC OR LATINO											OVERALL TOTALS		
			***** MALE *****						***** FEMALE *****							
	MALE	FEMALE	WHITE	BLACK OR AFRICAN AMERICAN	NATIVE HAWAIIAN OR PACIFIC ISLANDER	ASIAN	AMERICAN INDIAN OR ALASKAN NATIVE	TWO OR MORE RACES	WHITE	BLACK OR AFRICAN AMERICAN	NATIVE HAWAIIAN OR PACIFIC ISLANDER	ASIAN	AMERICAN INDIAN OR ALASKAN NATIVE		TWO OR MORE RACES	
EXECUTIVE/SR OFFICIALS & MGRS	0	0	7	0	0	0	0	0	0	0	0	0	0	0	0	7
FIRST/MID OFFICIALS & MGRS	6	2	109	3	0	6	1	0	41	0	0	0	0	0	0	168
PROFESSIONALS	17	10	298	3	2	9	0	3	125	1	1	5	0	5	477	
TECHNICIANS	20	2	156	7	0	4	0	7	20	1	0	1	0	2	220	
SALES WORKERS	0	0	0	0	0	0	0	0	0	0	0	0	0	0	0	
ADMINISTRATIVE SUPPORT	2	9	17	1	0	0	0	1	87	0	0	1	0	2	120	
CRAFT WORKERS	0	0	0	0	0	0	0	0	0	0	0	0	0	0	0	
OPERATIVES	17	30	87	1	0	6	1	4	65	1	0	5	1	1	219	
LABORERS & HELPERS	0	0	8	0	0	0	0	0	3	0	0	0	0	0	11	
SERVICE WORKERS	0	2	0	0	0	0	0	0	1	0	0	0	0	0	3	
TOTAL	62	55	680	15	2	25	2	15	342	3	1	12	1	10	1226	
PREVIOUS REPORT TOTAL	58	50	643	17	2	21	2	15	324	1	0	13	1	11	1168	

SECTION F - REMARKS

CO= 1027831
 UE= C840153

**EQUAL EMPLOYMENT OPPORTUNITY
 2018 EMPLOYER INFORMATION REPORT
 INDIVIDUAL ESTABLISHMENT REPORT - TYPE 4**

SECTION B - COMPANY IDENTIFICATION

1. **DANAHER CORPORATION**
 2200 PENNSYLVANIA AVE STE 800W
 WASHINGTON, DC 20037

2a. **HACH COMPANY**
 100 DAYTON AVENUE
 BUILDING # 1
 AMES, IA 50010
 STORY COUNTY
 c. Y

SECTION C - TEST FOR FILING REQUIREMENT

1-Y 2-Y 3-Y DUNS NO.:005288679 EIN :420704420

SECTION E - ESTABLISHMENT INFORMATION

NAICS: 334516 Analytical Laboratory
 Instrument Manufacturing

SECTION D - EMPLOYMENT DATA

JOB CATEGORIES	HISPANIC OR LATINO		NOT-HISPANIC OR LATINO											OVERALL TOTALS		
	***** MALE *****											***** FEMALE *****				
	MALE	FEMALE	WHITE	BLACK OR AFRICAN AMERICAN	NATIVE HAWAIIAN OR PACIFIC ISLANDER	ASIAN	AMERICAN INDIAN OR ALASKAN NATIVE	TWO OR MORE RACES	WHITE	BLACK OR AFRICAN AMERICAN	NATIVE HAWAIIAN OR PACIFIC ISLANDER	ASIAN	AMERICAN INDIAN OR ALASKAN NATIVE		TWO OR MORE RACES	
EXECUTIVE/SR OFFICIALS & MGRS	0	0	0	0	0	0	0	0	0	0	0	0	0	0	0	0
FIRST/MID OFFICIALS & MGRS	1	0	21	0	0	0	0	0	7	0	0	0	0	0	0	29
PROFESSIONALS	2	1	24	0	0	3	0	0	17	0	0	1	0	1	49	
TECHNICIANS	0	0	80	5	0	3	0	1	12	0	0	0	0	0	81	
SALES WORKERS	0	0	0	0	0	0	0	0	0	0	0	0	0	0	0	
ADMINISTRATIVE SUPPORT	1	1	10	0	0	0	0	0	23	1	0	0	0	0	36	
CRAFT WORKERS	0	0	0	0	0	0	0	0	0	0	0	0	0	0	0	
OPERATIVES	5	8	102	5	1	4	0	1	80	0	0	3	0	0	187	
LABORERS & HELPERS	2	2	48	5	0	0	0	0	40	1	0	0	0	1	97	
SERVICE WORKERS	0	0	0	0	0	0	0	0	0	0	0	0	0	0	0	
TOTAL	11	10	283	15	1	10	0	2	159	2	0	4	0	2	478	
PREVIOUS REPORT TOTAL	8	6	278	13	1	10	2	1	158	5	0	6	0	2	488	

SECTION F - REMARKS



Be Right™

Bid

Quote Number: 100357218v2
Use quote number at time of order to ensure that you receive prices quoted

Hach
PO Box 608
Loveland, CO 80539-0608
Phone: (800) 227-4224
Email: quotes@hach.com
Website: www.hach.com

Quote Date: 27-Jan-2020

Quote Expiration: 27-Mar-2020

Lexington Fayette

Name: Brian Marcum
Phone: 8592583329
Email: BrianM@lexingtonky.gov

Customer Quote Reference: #Bid # 15-2020

Sales Contact: Lance Williams Email: lwlliam@hach.com Phone: 859-940-3787

PRICING QUOTATION

Line	Part Number	Description	Qty	Unit Price	Net Unit Price
1	LXV404.99.00552	sc200 CONTROLLER, AC-DC, 2 DIG, HACH	1	2,219.00	2,219.00
2	9220600	COVER ASSY, UV &SUN SHIELD, sc200	1	233.00	233.00
3	8809200	COVER ASSY, UV, sc200	1	171.00	171.00
4	9218200	READER, SD CARD HIGH CAPACITY	1	47.25	47.25
5	9218100	MEMORY CARD, SECURE DIGITAL HIGH CAPACITY 4GB	1	62.75	62.75
6	9012900	SENSOR MODULE, pH/ORP/DO, sc200, HACH	1	432.00	432.00
7	9012800	SENSOR MODULE, 4-20 mA INPUT, sc 200, HACH	1	432.00	432.00
8	9013200	NETWORK MODULE, MODBUS, sc200, HACH	1	601.00	601.00
9	9173900	KIT, NETWORK MODULE, PROFIBUS, sc200	1	619.00	619.00
10	9334600	KIT, NETWORK MODULE, POWERED 4-20mA OUTPUT, sc200, HACH	1	379.00	379.00
11	9202900	KIT, POWER CORD, sc200 NORTH AMERICA ACCESSORIES	1	66.45	66.45
12	5794400	LDO Pole Mount Kit	1	524.00	524.00
13	5794300	LDO Ball Float Mounting Kit	1	719.00	719.00
14	5867000	Digital Termination Box	1	201.00	201.00
15	5796000	Digital Extension Cable, 7.7m (25ft)	1	204.00	204.00
16	5796100	Digital Extension Cable, 15m (50 ft)	1	303.00	303.00
17	5796200	Digital Extension Cable, 31m (100ft)	1	401.00	401.00
18	6860001	KTO: HOAB COMPRESSOR AND LDO AIRBLAST	1	2,242.00	2,242.00
19	5791100	LDO Replacement Sensor Cap	1	305.00	305.00

Line	Part Number	Description	Qty	Unit Price	Net Unit Price
20	9020000	ASSY, PROBE, LDO MODEL 2, HACH	1	2,131.00	2,131.00
21	9021100	KIT, SENSOR CAP REPLACEMENT, LDO MODEL 2, HACH	1	233.00	233.00
22	9253000	KTO: POLE MOUNT, 1" NPT SENSOR	1	537.00	537.00
23	9253100	KTO: FLOAT MOUNT, 1" NPT SENSOR	1	737.00	737.00
24	9253100	KTO: FLOAT MOUNT, 1" NPT SENSOR	1	737.00	737.00
25	7300800	ASSY, PHD & NH4D FLOW CELL	1	537.00	537.00
26	57P	** Field Svc HALF DAY StartUp-PROCESS (P)	1	1,147.00	1,147.00
		Start up travel listed below for half day of start up services listed above			
27	STARTUP TRAVEL	** Field Svc HACH START UP TRAVEL CHG	1	250.00	250.00
28	59P	** Field Svc FULL DAY StartUp-PROCESS (P)	1	2,295.00	2,295.00
		Start up travel listed below for full day of start up services listed above			
29	STARTUP TRAVEL	** Field Svc HACH START UP TRAVEL CHG	1	250.00	250.00
				Grand Total	\$ 19,015.45

NOTES

TERMS OF SALE

Freight: Ground Prepay and Add

FOB: Origin

All purchases of Hach Company products and/or services are expressly and without limitation subject to Hach Company's Terms & Conditions of Sale ("Hach TCS"), incorporated herein by reference and published on Hach Company's website at www.hach.com/terms. Hach TCS are contained directly and/or by reference in Hach's offer, order acknowledgment, and invoice documents. The first of the following acts constitutes an acceptance of Hach's offer and not a counteroffer and creates a contract of sale "Contract" in accordance with the Hach TCS: (i) Buyer's issuance of a purchase order document against Hach's offer; (ii) acknowledgment of Buyer's order by Hach; or (iii) commencement of any performance by Hach pursuant to Buyer's order. Provisions contained in Buyer's purchase documents (including electronic commerce interfaces) that materially alter, add to or subtract from the provisions of the Hach TCS are not part of the Contract.

Due to international regulations, a U.S. Department of Commerce Export License may be required. Hach reserves the right to approve specific shipping agents. Wooden boxes suitable for ocean shipment are extra. Specify final destination to ensure proper documentation and packing suitable for international transport. In addition, Hach may require: 1) A statement of intended end-use; 2) Certification that the intended end-use does not relate to proliferation of weapons of mass destruction (prohibited nuclear end use, chemical / biological weapons, missile technology); and 3) Certification that the goods will not be diverted contrary to U.S. and/or applicable laws in force in Buyer's jurisdiction.

ORDER TERMS:

Terms are Subject to Credit Review

Please reference the quotation number on your purchase order.

Sales tax is not included. Applicable sales tax will be added to the invoice based on the U.S. destination, if applicable provide a resale/exemption certificate.

Shipments will be prepaid and added to invoices unless otherwise specified.

Equipment quoted operates with standard U.S. supply voltage.

Hach standard terms and conditions apply to all sales.

Additional terms and conditions apply to orders for service partnerships.

Prices do not include delivery of product. Reference attached Freight Charge Schedule and Collect Handling Fees.

Standard lead time is 30 days.

This Quote is good for a one time purchase.

Sales Contact:

Name: Lance Williams
Title: Regional Sales Manager
Phone: 859-940-3787
Email: lwilliam@hach.com



Be Right™

Quotation Addendum

HACH COMPANY

Headquarters
P.O. Box 389
5600 Lindbergh Drive
Loveland, CO 80539-0389

Purchase Orders
PO Box 608
Loveland, CO 80539-0608

WebSite: www.hach.com

U.S.A.
Phone: 800-227-4224
Fax: 970-669-2932
E-Mail: orders@hach.com
quotes@hach.com
techhelp@hach.com

Export
Phone: 970-669-3050
Fax: 970-481-3939
Email: Intl@hach.com

Remittance
2207 Collections Center Drive
Chicago, IL 60693

Wire Transfers
Bank of America
231 S. LaSalle St.
Chicago, IL 60604
Account: 8765602385
Routing (ABA): 071000039

ADVANTAGES OF WORKING WITH HACH

<p>Hach Service</p> <p><i>Protect your investment & peace of mind</i></p> <ul style="list-style-type: none"> ✓ A global partner who understands your needs ✓ Delivers timely, high-quality service you can trust ✓ Provides team of unique experts to help you maximize instrument uptime ✓ Ensure data integrity ✓ Maintain operational stability ✓ Reduce compliance risk <p>www.hach.com/service-contracts</p>	<p>Pick&Ship™</p> <p><i>Pick&Ship™ Program offers a better way to keep your supplies in stock</i></p> <ul style="list-style-type: none"> ✓ Convenience of one purchase order for the entire year ✓ Flexibility to change, cancel or create new orders ✓ Savings from locking in prices & thus avoiding price surges and rush charges ✓ Peace of mind with automatic, reliable shipments just as you need them <p>www.Hach.com/pickandship</p>	<p>Technical Support</p> <p><i>Provides post-sale instrumentation and application support</i></p> <ul style="list-style-type: none"> ✓ Hach's highly skilled Technical Support staff is dedicated to helping you resolve technical issues before, during and after the sale. ✓ Available via phone, e-mail, or live online chat at Hach.com! ✓ Fast access to answers at https://support.hach.com ✓ Toll-free phone: 800-227-4224 ✓ E-mail: techhelp@hach.com <p>www.Hach.com</p>
--	--	--

ADVANTAGES OF SIMPLIFIED SHIPPING AND HANDLING

<p>Safe & Fast Delivery</p> <ul style="list-style-type: none"> ✓ Receive tracking numbers on your order acknowledgement ✓ Hach will assist with claims if an order is lost or damaged in shipment 	<p>Save Time – Less Hassle</p> <ul style="list-style-type: none"> ✓ No need to set up deliveries for orders or to schedule pickup ✓ Hach ships order as product is available, at no additional charge, when simplified shipping and handling is used. 	<p>Save Money</p> <ul style="list-style-type: none"> ✓ No additional invoice to process – save on time and administrative costs ✓ Only pay shipping once, even if multiple shipments are required
--	--	--

STANDARD SIMPLIFIED SHIPPING AND HANDLING CHARGES ^{1, 2, 3}						Collect ⁴ Handling Fee Effective 8/31/19
Total Price of Merchandise Ordered	Standard Surface (Mainland USA)	Second Day Delivery (Mainland USA)	Next Day Delivery (Mainland USA)	Second Day Delivery (Alaska & Hawaii)	Next Day Delivery (Alaska & Hawaii)	
\$0.00 - \$49.99	\$11.99	\$29.99	\$55.93	\$48.14	\$91.51	\$8.98
\$50.00 - \$149.99	\$19.06	\$56.16	\$106.00	\$80.56	\$153.15	\$9.23
\$150.00 - \$349.99	\$33.48	\$89.32	\$181.94	\$112.71	\$219.36	\$9.81
\$350.00 - \$649.99	\$46.63	\$121.94	\$242.50	\$152.43	\$295.17	\$10.32
\$650.00 - \$949.99	\$58.77	\$127.42	\$286.85	\$157.77	\$297.40	\$10.69
\$950.00 - \$1,999.99	\$73.94	\$157.23	\$332.46	\$187.11	\$362.04	\$11.68
\$2,000.00 - \$3,999.99	\$85.36	\$167.09	\$342.29	\$194.36	\$369.69	\$13.48
\$4,000.00 - \$5,999.99	\$98.86	\$173.55	\$358.82	\$195.26	\$380.35	\$16.60
\$6,000.00 - \$7,999.99	\$116.93	\$197.60	\$408.56	\$215.38	\$415.24	\$19.36
\$8,000.00 - \$9,999.99	\$133.43	\$224.55	\$436.79	\$240.27	\$455.68	\$22.34
Over \$10,000	2% of Net Order Value	4% of Net Order Value	6% of Net Order Value	4% of Net Order Value	6% of Net Order Value	\$34.56

- Shipping & Handling charges shown are only applicable to orders billing and shipping to U.S. destinations. Shipping & Handling charges will be prepaid and added to invoice. Shipping & Handling for the Pick&Ship Program is charged on each shipment release and is based on the total price of each shipment release. Shipping & Handling charges are subject to change without notice.
- Additional Shipping & Handling charges will be applied to orders containing bulky and/or especially heavy orders. Refrigerated and all weather Samplers do not qualify for simplified Shipping & Handling charges, and are considered heavy products. Dissolved Oxygen Sensors can be damaged if exposed to temps below freezing, causing sensor failure. Must be shipped over night or 2nd day air during the cold weather months.
- Orders shipping to Alaska or Hawaii: Additional Shipping & Handling charges may be applied at time of order processing. Second Day and Next Day delivery is not available to all destinations.
- Hach Company will assess a collect handling fee on orders with collect shipping terms. This handling fee covers the additional costs that Hach Company incurs from processing and managing collect shipments.

SALES TAX

Sales Tax is not included in the attached quotation. Applicable sales and usage taxes will be added to your invoice, at the time of order, based on U.S. destination of goods, unless a valid resale/exemption certificate for destination state is provided to the above address or fax number, attention of the Tax Dept.

TERMS & CONDITIONS OF SALE FOR HACH COMPANY PRODUCTS AND SERVICES

This document sets forth the Terms & Conditions of Sale for goods manufactured and/or supplied, and services provided, by Hach Company of Loveland, Colorado ("Hach") and sold to the original purchaser thereof ("Buyer"). Unless otherwise specifically stated herein, the term "Hach" includes only Hach Company and none of its affiliates. Unless otherwise specifically stated in a previously-executed written purchase agreement signed by authorized representatives of Hach and Buyer, these Terms & Conditions of Sale establish the rights, obligations and remedies of Hach and Buyer which apply to this offer and any resulting order or contract for the sale of Hach's goods and/or services ("Products").

1. APPLICABLE TERMS & CONDITIONS: These Terms & Conditions of Sale are contained directly and/or by reference in Hach's offer, order acknowledgment, and invoice documents. The first of the following acts constitutes an acceptance of Hach's offer and not a counteroffer and creates a contract of sale ("Contract") in accordance with these Terms & Conditions: (i) Buyer's issuance of a purchase order document against Hach's offer; (ii) acknowledgment of Buyer's order by Hach; or (iii) commencement of any performance by Hach pursuant to Buyer's order. Provisions contained in Buyer's purchase documents (including electronic commerce interfaces) that materially alter, add to or subtract from the provisions of these Terms & Conditions of Sale are not a part of the Contract.

2. CANCELLATION: Buyer may cancel goods orders subject to fair charges for Hach's expenses including handling, inspection, restocking, freight and invoicing charges as applicable, provided that Buyer returns such goods to Hach at Buyer's expense within 30 days of delivery and in the same condition as received. Buyer may cancel service orders on ninety (90) day prior written notice and refunds will be prorated based on the duration of the service plan. Inspections and re-instatement fees may apply upon cancellation or expiration of service programs. Seller may cancel all or part of any order prior to delivery without liability if the order includes any Products that Seller determines may not comply with export, safety, local certification, or other applicable compliance requirements.

3. DELIVERY: Delivery will be accomplished FCA Hach's facility located in Ames, Iowa or Loveland, Colorado, United States (Incoterms 2010). Legal title and risk of loss or damage pass to Buyer upon transfer to the first carrier. Hach will use commercially reasonable efforts to deliver the Products ordered herein within the time specified on the face of this Contract or, if no time is specified, within Hach's normal lead-time necessary for Hach to deliver the Products sold hereunder. Upon prior agreement with Buyer and for an additional charge, Hach will deliver the Products on an expedited basis. Standard service delivery hours are 8 am - 5 pm Monday through Friday, excluding holidays.

4. INSPECTION: Buyer will promptly inspect and accept any Products delivered pursuant to this Contract after receipt of such Products. In the event the Products do not conform to any applicable specifications, Buyer will promptly notify Hach of such nonconformance in writing. Hach will have a reasonable opportunity to repair or replace the nonconforming product at its option. Buyer will be deemed to have accepted any Products delivered hereunder and to have waived any such nonconformance in the event such a written notification is not received by Hach within thirty (30) days of delivery.

5. PRICES & ORDER SIZES: All prices are in U.S. dollars and are based on delivery as stated above. Prices do not include any charges for services such as insurance; brokerage fees; sales, use, inventory or excise taxes; import or export duties; special financing fees; VAT, income or royalty taxes imposed outside the U.S.; consular fees; special permits or licenses; or other charges imposed upon the production, sale, distribution, or delivery of Products. Buyer will either pay any and all such charges or provide Hach with acceptable exemption certificates, which obligation survives performance under this Contract. Hach reserves the right to establish minimum order sizes and will advise Buyer accordingly.

6. PAYMENTS: All payments must be made in U.S. dollars. For internet orders, the purchase price is due at the time and manner set forth at www.hach.com. Invoices for all other orders are due and payable NET 30 DAYS from date of the invoice without regard to delays for inspection or transportation, with payments to be made by check to Hach at the above address or by wire transfer to the account stated on the front of Hach's invoice, or for customers with no established credit, Hach may require cash or credit

card payment in advance of delivery. In the event payments are not made or not made in a timely manner, Hach may, in addition to all other remedies provided at law, either: (a) declare Buyer's performance in breach and terminate this Contract for default; (b) withhold future shipments until delinquent payments are made; (c) deliver future shipments on a cash-with-order or cash-in-advance basis even after the delinquency is cured; (d) charge interest on the delinquency at a rate of 1-1/2% per month or the maximum rate permitted by law, if lower, for each month or part thereof of delinquency in payment plus applicable storage charges and/or inventory carrying charges; (e) repossess the Products for which payment has not been made; (f) recover all costs of collection including reasonable attorney's fees; or (g) combine any of the above rights and remedies as is practicable and permitted by law. Buyer is prohibited from setting off any and all monies owed under this from any other sums, whether liquidated or not, that are or may be due Buyer, which arise out of a different transaction with Hach or any of its affiliates. Should Buyer's financial responsibility become unsatisfactory to Hach in its reasonable discretion, Hach may require cash payment or other security. If Buyer fails to meet these requirements, Hach may treat such failure as reasonable grounds for repudiation of this Contract, in which case reasonable cancellation charges shall be due Hach. Buyer grants Hach a security interest in the Products to secure payment in full, which payment releases the security interest but only if such payments could not be considered an avoidable transfer under the U.S. Bankruptcy Code or other applicable laws. Buyer's insolvency, bankruptcy, assignment for the benefit of creditors, or dissolution or termination of the existence of Buyer, constitutes a default under this Contract and affords Hach all the remedies of a secured party under the U.C.C., as well as the remedies stated above for late payment or non-payment. See [120](#) for further wire transfer requirements.

7. LIMITED WARRANTY: Hach warrants that Products sold hereunder will be free from defects in material and workmanship and will, when used in accordance with the manufacturer's operating and maintenance instructions, conform to any express written warranty pertaining to the specific goods purchased, which for most Hach instruments is for a period of twelve (12) months from delivery. Hach warrants that services furnished hereunder will be free from defects in workmanship for a period of ninety (90) days from the completion of the services. Parts provided by Hach in the performance of services may be new or refurbished parts functioning equivalent to new parts. Any non-functioning parts that are repaired by Hach shall become the property of Hach. No warranties are extended to consumable items such as, without limitation, reagents, batteries, mercury cells, and light bulbs. All other guarantees, warranties, conditions and representations, either express or implied, whether arising under any statute, law, commercial usage or otherwise, including implied warranties of merchantability and fitness for a particular purpose, are hereby excluded. The sole remedy for Products not meeting this Limited Warranty is replacement, credit or refund of the purchase price. This remedy will not be deemed to have failed of its essential purpose so long as Hach is willing to provide such replacement, credit or refund.

8. INDEMNIFICATION: Indemnification applies to a party and to such party's successors-in-interest, assignees, affiliates, directors, officers, and employees ("Indemnified Parties"). Hach is responsible for and will defend, indemnify and hold harmless the Buyer Indemnified Parties against all losses, claims, expenses or damages which may result from accident, injury, damage, or death due to Hach's breach of the Limited Warranty. Buyer is responsible for and will defend, indemnify and hold harmless the Hach Indemnified Parties against all losses, claims, expenses or damages which may result from accident, injury, damage, or death due to negligence, misuse or misapplication of any goods or services, violations of law, or the breach of any provision of this Contract by the Buyer, its affiliates, or those employed by, controlled by or in privity with them. Buyer's workers' compensation immunity, if any, does not preclude or limit its indemnification obligations.

9. PATENT PROTECTION: Subject to all limitations of liability provided herein, Hach will, with respect to any Products of Hach's design or manufacture, indemnify Buyer from any and all damages and costs as finally determined by a court of competent jurisdiction in any suit for infringement of any U.S. patent (or European patent for Products that Hach sells to Buyer for end use in a member state of the E.U.) that has issued as of the delivery date, solely by reason of the sale or normal use of any Products sold to Buyer hereunder and from reasonable expenses incurred by Buyer in defense of such suit if Hach does not undertake the defense thereof, provided that Buyer promptly notifies



TERMS AND CONDITIONS OF SALE FOR HACH® PRODUCTS

Hach of such suit and offers Hach either (i) full and exclusive control of the defense of such suit when Products of Hach only are involved, or (ii) the right to participate in the defense of such suit when products other than those of Hach are also involved. Hach's warranty as to use patents only applies to infringement arising solely out of the inherent operation of the Products according to their applications as envisioned by Hach's specifications. In case the Products are in such suit held to constitute infringement and the use of the Products is enjoined, Hach will, at its own expense and at its option, either procure for Buyer the right to continue using such Products or replace them with non-infringing products, or modify them so they become non-infringing, or remove the Products and refund the purchase price (prorated for depreciation) and the transportation costs thereof. The foregoing states the entire liability of Hach for patent infringement by the Products. Further, to the same extent as set forth in Hach's above obligation to Buyer, Buyer agrees to defend, indemnify and hold harmless Hach for patent infringement related to (x) any goods manufactured to the Buyer's design, (y) services provided in accordance with the Buyer's instructions, or (z) Hach's Products when used in combination with any other devices, parts or software not provided by Hach hereunder.

10. TRADEMARKS AND OTHER LABELS: Buyer agrees not to remove or alter any indicia of manufacturing origin or patent numbers contained on or within the Products, including without limitation the serial numbers or trademarks on nameplates or cast, molded or machined components.

11. SOFTWARE AND DATA. All licenses to Hach's separately-provided software products are subject to the separate software license agreement(s) accompanying the software media and/or included as an Appendix to these Terms & Conditions of Sale. Except to the extent such express licenses conflict with the remainder of this paragraph, the following also applies relative to Hach's software: Hach grants Buyer only a personal, non-exclusive license to access and use the software provided by Hach with Products purchased hereunder solely as necessary for Buyer to enjoy the benefit of the Products. A portion of the software may contain or consist of open source software, which Buyer may use under the terms and conditions of the specific license under which the open source software is distributed. Buyer agrees that it will be bound by all such license agreements. Title to software remains with the applicable licensor(s). In connection with Buyer's use of Products, Hach may obtain, receive, or collect data or information, including data produced by the Products. In such cases, Buyer grants Hach a non-exclusive, worldwide, royalty-free, perpetual, non-revocable license to use, compile, distribute, display, store, process, reproduce, or create derivative works of such data, or to aggregate such data for use in an anonymous manner, solely to facilitate marketing, sales and R&D activities of Hach and its affiliates.

12. PROPRIETARY INFORMATION; PRIVACY: "Proprietary Information" means any information, technical data or know-how in whatever form, whether documented, contained in machine readable or physical components, mask works or artwork, or otherwise, which Hach considers proprietary, including but not limited to service and maintenance manuals. Buyer and its customers, employees and agents will keep confidential all such Proprietary Information obtained directly or indirectly from Hach and will not transfer or disclose it without Hach's prior written consent, or use it for the manufacture, procurement, servicing or calibration of Products or any similar products, or cause such products to be manufactured, serviced or calibrated by or procured from any other source, or reproduce or otherwise appropriate it. All such Proprietary Information remains Hach's property. No right or license is granted to Buyer or its customers, employees or agents, expressly or by implication, with respect to the Proprietary Information or any patent right or other proprietary right of Hach, except for the limited use licenses implied by law. Hach will manage Customer's information and personal data in accordance with its Privacy Policy, located at <http://www.hach.com/privacypolicy>.

13. CHANGES AND ADDITIONAL CHARGES: Hach reserves the right to make design changes or improvements to any products of the same general class as Products being delivered hereunder without liability or obligation to incorporate such changes or improvements to Products ordered by Buyer unless agreed upon in writing before the Products' delivery date. Services which must be performed as a result of any of the following conditions are subject to additional charges for labor, travel and parts: (a) equipment alterations not authorized in writing by Hach; (b) damage resulting from improper use or handling, accident, neglect, power surge, or operation in an environment or manner in which the instrument is not designed to operate or

is not in accordance with Hach's operating manuals; (c) the use of parts or accessories not provided by Hach; (d) damage resulting from acts of war, terrorism or nature; (e) services outside standard business hours; (f) site prep work not complete per proposal; or (g) any repairs required to ensure equipment meets manufacturer's specifications upon activation of a service agreement.

14. SITE ACCESS / PREPARATION / WORKER SAFETY / ENVIRONMENTAL COMPLIANCE: In connection with services provided by Hach, Buyer agrees to permit prompt access to equipment. Buyer assumes full responsibility to back-up or otherwise protect its data against loss, damage or destruction before services are performed. Buyer is the operator and in full control of its premises, including those areas where Hach employees or contractors are performing service, repair and maintenance activities. Buyer will ensure that all necessary measures are taken for safety and security of working conditions, sites and installations during the performance of services. Buyer is the generator of any resulting wastes, including without limitation hazardous wastes. Buyer is solely responsible to arrange for the disposal of any wastes at its own expense. Buyer will, at its own expense, provide Hach employees and contractors working on Buyer's premises with all information and training required under applicable safety compliance regulations and Buyer's policies. If the instrument to be serviced is in a Confined Space, as that term is defined under OSHA regulations, Buyer is solely responsible to make it available to be serviced in an unconfined space. Hach service technicians will not work in Confined Spaces. In the event that a Buyer requires Hach employees or contractors to attend safety or compliance training programs provided by Buyer, Buyer will pay Hach the standard hourly rate and expense reimbursement for such training attended. The attendance at or completion of such training does not create or expand any warranty or obligation of Hach and does not serve to alter, amend, limit or supersede any part of this Contract.

15. LIMITATIONS ON USE: Buyer will not use any Products for any purpose other than those identified in Hach's catalogs and literature as intended uses. Unless Hach has advised the Buyer in writing, in no event will Buyer use any Products in drugs, food additives, food or cosmetics, or medical applications for humans or animals. In no event will Buyer use in any application any Product that requires FDA 510(k) clearance unless and only to the extent the Product has such clearance. Buyer will not sell, transfer, export or re-export any Hach Products or technology for use in activities which involve the design, development, production, use or stockpiling of nuclear, chemical or biological weapons or missiles, nor use Hach Products or technology in any facility which engages in activities relating to such weapons. Unless the "ship-to" address is in California, U.S.A., the Products are not intended for sale in California and may lack markings required by California Proposition 65; accordingly, unless Buyer has ordered Products specifying a California ship-to address, Buyer will not sell or deliver any Hach Products for use in California. Any warranty granted by Hach is void if any goods covered by such warranty are used for any purpose not permitted hereunder.

16. EXPORT AND IMPORT LICENSES AND COMPLIANCE WITH LAWS: Unless otherwise specified in this Contract, Buyer is responsible for obtaining any required export or import licenses. Buyer will comply with all laws and regulations applicable to the installation or use of all Products, including applicable import and export control laws and regulations of the U.S., E.U. and any other country having proper jurisdiction, and will obtain all necessary export licenses in connection with any subsequent export, re-export, transfer and use of all Products and technology delivered hereunder. Buyer will comply with all local, national, and other laws of all jurisdictions globally relating to anti-corruption, bribery, extortion, kickbacks, or similar matters which are applicable to Buyer's business activities in connection with this Contract, including but not limited to the U.S. Foreign Corrupt Practices Act of 1977, as amended (the "FCPA"). Buyer agrees that no payment of money or provision of anything of value will be offered, promised, paid or transferred, directly or indirectly, by any person or entity, to any government official, government employee, or employee of any company owned in part by a government, political party, political party official, or candidate for any government office or political party office to induce such organizations or persons to use their authority or influence to obtain or retain an improper business advantage for Buyer or for Hach, or which otherwise constitutes or have the purpose or effect of public or commercial bribery, acceptance of or acquiescence in extortion, kickbacks or other unlawful or improper means of obtaining business or any improper advantage, with respect to any of Buyer's activities related to this Contract. Hach asks Buyer to "Speak Up!" if aware of any violation of law,

TERMS AND CONDITIONS OF SALE FOR HACH® PRODUCTS

regulation or our Standards of Conduct ("SOC") in relation to this Contract. See <http://danaher.com/integrity-and-compliance> and www.danaherintegrity.com for a copy of the SOC and for access to our Helpline portal.

17. RELATIONSHIP OF PARTIES: Buyer is not an agent or representative of Hach and will not present itself as such under any circumstances unless and to the extent it has been formally screened by Hach's compliance department and received a separate duly-authorized letter from Hach setting forth the scope and limitations of such authorization.

18. FORCE MAJEURE: Hach is excused from performance of its obligations under this Contract to the extent caused by acts or omissions that are beyond its control of, including but not limited to Government embargoes, blockages, seizures or freeze of assets, delays or refusals to grant an export or import license or the suspension or revocation thereof, or any other acts of any Government; fires, floods, severe weather conditions, or any other acts of God; quarantines; labor strikes or lockouts; riots; strife; insurrections; civil disobedience or acts of criminals or terrorists; war; material shortages or delays in deliveries to Hach by third parties. In the event of the existence of any force majeure circumstances, the period of time for delivery, payment terms and payments under any letters of credit will be extended for a period of time equal to the period of delay. If the force majeure circumstances extend for six months, Hach may, at its option, terminate this Contract without penalty and without being deemed in default or in breach thereof.

19. NON ASSIGNMENT AND WAIVER: Buyer will not transfer or assign this Contract or any rights or interests hereunder without Hach's prior written consent. Failure of either party to insist upon strict performance of any provision of this Contract, or to exercise any right or privilege contained herein, or the waiver of any breach of the terms or conditions of this Contract will not be construed as thereafter waiving any such terms, conditions, rights, or privileges, and the same will continue and remain in force and effect as if no waiver had occurred.

20. WIRE TRANSFERS: Buyer and Hach both recognize that there is a risk of wire fraud when individuals impersonating a business demand immediate payment under new wire transfer instructions. To avoid this risk, Buyer must verbally confirm any new or changed wire transfer instructions by calling Hach at +1-970-863-1377 and speaking with Hach's Credit Manager before transferring any monies using the new wire instructions. Both parties agree that they will not institute wire transfer instruction changes and require immediate payment under the new instructions but will instead provide a ten (10) day grace period to verify any wire transfer instruction changes before any outstanding payments are due using the new instructions.

21. LIMITATION OF LIABILITY: None of the Hach Indemnified Parties will be liable to Buyer under any circumstances for any special, treble, incidental or consequential damages, including without limitation, damage to or loss of property other than for the Products purchased hereunder; damages incurred in installation, repair or replacement; lost profits, revenue or opportunity; loss of use; losses resulting from or related to downtime of the products or inaccurate measurements or reporting; the cost of substitute products; or claims of Buyer's customers for such damages, howsoever caused, and whether based on warranty, contract, and/or tort (including negligence, strict liability or otherwise). The total liability of the Hach Indemnified Parties arising out of the performance or nonperformance hereunder or Hach's obligations in connection with the design, manufacture, sale, delivery, and/or use of Products will in no circumstance exceed in the aggregate a sum equal to twice the amount actually paid to Hach for Products delivered hereunder.

22. APPLICABLE LAW AND DISPUTE RESOLUTION: The construction, interpretation and performance hereof and all transactions hereunder shall be governed by the laws of the State of Colorado, without regard to its principles or laws regarding conflicts of laws. If any provision of this Contract violates any Federal, State or local statutes or regulations of any countries having jurisdiction of this transaction, or is illegal for any reason, said provision shall be self-deleting without affecting the validity of the remaining provisions. Unless otherwise specifically agreed upon in writing between Hach and Buyer, any dispute relating to this Contract which is not resolved by the parties shall be adjudicated in order of preference by a court of competent jurisdiction (i) in the State of Colorado, U.S.A. if Buyer has minimum contacts with Colorado and the U.S., (ii) elsewhere in the U.S. if Buyer has minimum contacts with the

U.S. but not Colorado, or (iii) in a neutral location if Buyer does not have minimum contacts with the United States.

23. ENTIRE AGREEMENT & MODIFICATION: These Terms & Conditions of Sale constitute the entire agreement between the parties and supersede any prior agreements or representations, whether oral or written. No change to or modification of these Terms & Conditions shall be binding upon Hach unless in a written instrument specifically referencing that it is amending these Terms & Conditions of Sale and signed by an authorized representative of Hach. Hach rejects any additional or inconsistent Terms & Conditions of Sale offered by Buyer at any time, whether or not such terms or conditions materially alter the Terms & Conditions herein and irrespective of Hach's acceptance of Buyer's order for the described goods and services.

24. APPENDICES: If checked, the following Appendices are attached hereto and incorporated by reference into these Terms & Conditions of Sale:

CLAROS SOFTWARE AS A SERVICE SUBSCRIPTION AGREEMENT

* * *

DISSOLVED OXYGEN: HACH LDO® PROBE, MODEL 2

Applications

- Wastewater
- Industrial Water
- Drinking Water



Take “No” for an answer when measuring dissolved oxygen with the next generation Hach LDO probe.

No Calibration Required

The Hach LDO probe is ready to work in your process right out of the box with no calibration required for the entire 2-year life of the sensor cap.

No Membranes to Replace

There is virtually no maintenance with Hach’s breakthrough luminescent technology. There are no membranes to replace, no electrolyte solution to replenish, and no anode or cathode to clean.

No Missed Cleaning Cycles

Customizable service indicators trigger a service message so that a cleaning cycle is never missed.

No Drift

A cutting-edge, 3D calibration procedure at the factory makes oxygen measurement with the Hach LDO probe more accurate than ever before.

No Complications

A robust new design gives the Hach LDO enhanced durability and reduced size for easier handling.



Be Right™

Specifications*

Range	0 to 20.00 ppm
	0 to 20.0 mg/L (or ppm)
	0 to 200 % air saturation
Accuracy	± 0.05 ppm below 1 ppm
	± 0.1 ppm below 5 ppm
	± 0.2 ppm above 5 ppm
Response Time	$T_{95} < 60$ s
	$T_{90} < 40$ s
Resolution	0.01 ppm DO
	0.1% saturation
Repeatability	± 0.1 (mg/L) ppm

Flow Rate	None required
Sensor Immersion Depth	Down to 345 kPa (50 psi), maximum; accuracy may not be maintained at this depth
Transmission Distance	1000 m (3280 ft.) maximum when used with a termination box
Cable Length	10 m (options with 30m, 60m, 100m)
Dimensions (D x L)	1.9 in x 10 in (48.25 mm x 254 mm)
Weight	2.2 lbs. (1 kg), probe only

*Subject to change without notice.

Principle of Operation

The HACH LDO sensor is coated with a luminescent material. Blue light from an LED is transmitted to the sensor surface. The blue light excites the luminescent material. As the material relaxes it emits red light. The time it takes for the red light to be emitted is measured. Between the flashes of blue light, a red LED is flashed on the sensor and used as an internal reference.

Increased oxygen in the sample decreases the time it takes for the red light to be emitted. The time measurements correlate to the oxygen concentration.

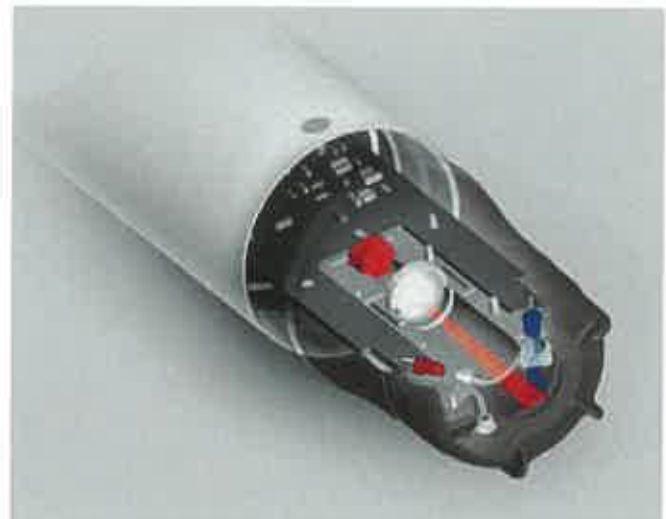

Dimensions

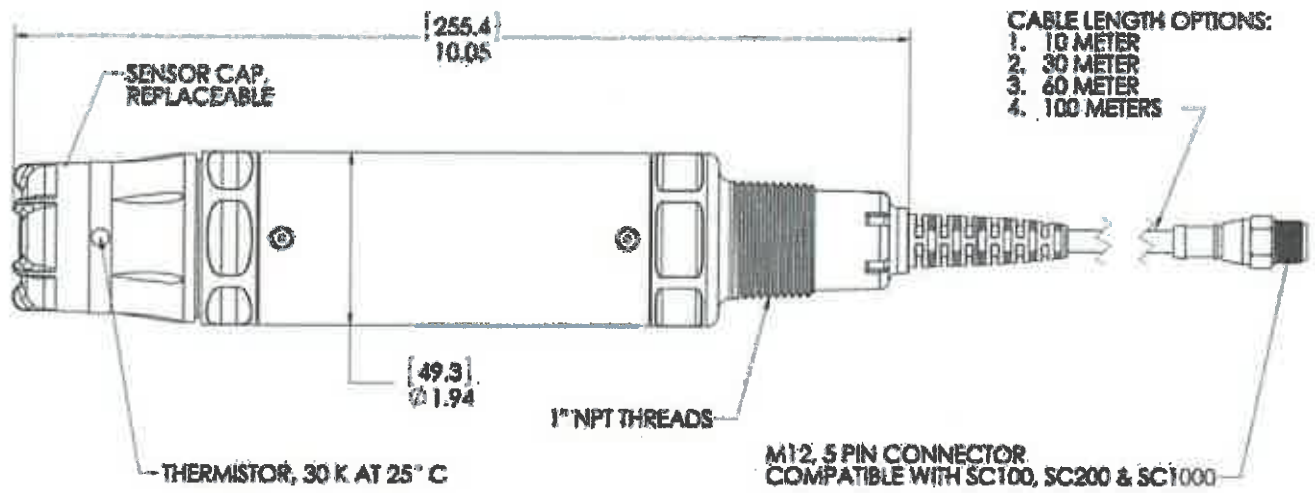

Installation / Mounting

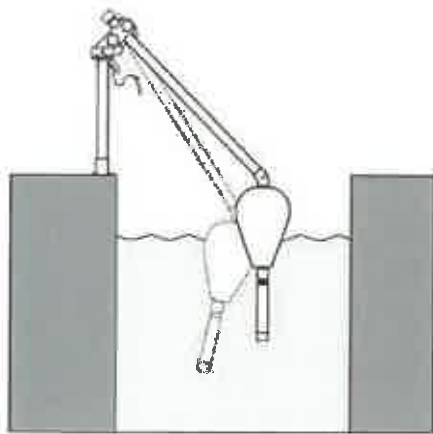

Float Mount Kit

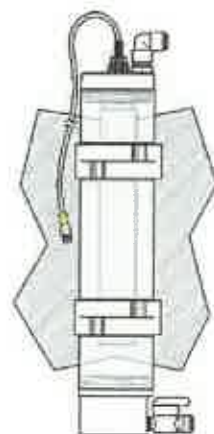

Flow Cell

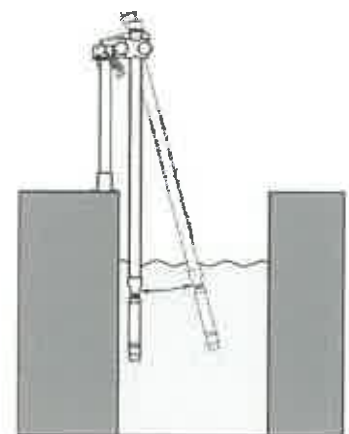

Pole Mount Kit

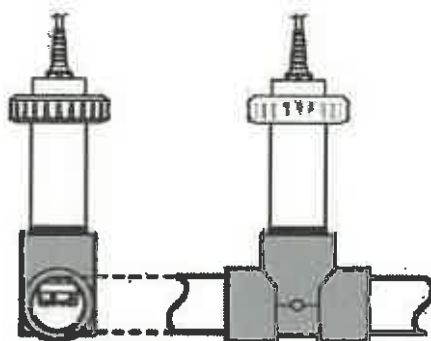

Union Mount Kit

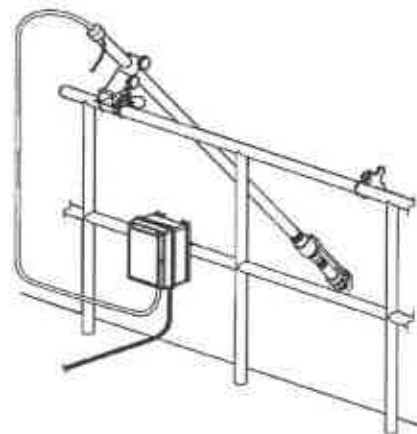

Air Blast Cleaning System

Ordering Information

9020000	Hach LDO Model 2 Probe
9020000-UPGRADE	LDO Probe, Mounting Conversion Adapter
9020000-SC200	LDO Probe, Mounting Conversion Adapter, sc200 controller with 2 channels

Accessories

5867000	Digital Termination Box
5796000	Digital Extension Cable, 7.7 m (25 ft.)
5796100	Digital Extension Cable, 15 m (50 ft.)
5796200	Digital Extension Cable, 31 m (100 ft.)
6860000	High Output Air Blast Cleaning System, 115 Vac
6860100	High Output Air Blast Cleaning System, 230 Vac
9253500	Air Blast Hardware Components

Replacement Parts

9021100	LDO Model 2 Sensor Cap Replacement Kit
----------------	--

Mounting Kits

9253000	Pole Mount Kit, PVC
9253100	Ball Float Mount Kit, PVC
9257000	Unlon Mount Kit, PVC
9253400	Mounting Conversion Adapter, LDO Model 1 to LDO Model 2
7300800	1 NPT sc Sensors Flow Cell

Controllers

sc200 Digital Controllers

LXV404.99.00552	sc200 controller, 2 channel, digital
LXV404.99.00542	sc200 controller, 2 channel, digital & mA Input
LXV404.99.00502	sc200 controller, 1 channel, digital
LXV404.99.00512	sc200 controller, 2 channel, digital & pH/DO
LXV404.99.00522	sc200 controller, 2 channel, digital & Conductivity
LXV404.99.00532	sc200 controller, 2 channel, digital & Flow

sc1000 Digital Controllers

LXV402.99.00002	sc1000 Display Module
LXV400.99.1R572	sc1000 Probe Module, 4 sensors, 4 mA Out, 4 mA In, 4 Relays, 110-230V
LXV400.99.1B572	sc1000 Probe Module, 4 sensors, 4 mA Out, 4 mA In, 4 Relays, Modbus RS485, 110-230V
LXV400.99.1F572	sc1000 Probe Module, 4 sensors, 4 mA Out, 4 mA In, 4 Relays, PROFIBUS DP, 110-230V
LXV400.99.1R582	sc1000 Probe Module, 6 sensors, 4 mA Out, 4 mA In, 4 Relays, 110-230V



HACH COMPANY World Headquarters: Loveland, Colorado USA

United States:	800-227-4224 tel	970-669-2932 fax	orders@hach.com
Outside United States:	970-669-3050 tel	970-461-3939 fax	int@hach.com
hach.com			

LIT2455 Rev 3

A14 Printed in U.S.A.

©Hach Company, 2014. All rights reserved.

In the interest of improving and updating its equipment,

Hach Company reserves the right to alter specifications to equipment at any time.



Be Right™

sc200™ UNIVERSAL CONTROLLER

Applications

- Drinking Water
- Wastewater
- Industrial Water
- Power



One Controller for the Broadest Range of Sensors.

Choose from 30 digital and analog sensor families for up to 17 different parameters.

Maximum Versatility

The sc200 controller allows the use of digital and analog sensors, either alone or in combination, to provide compatibility with Hach's broad range of sensors, eliminating the need for dedicated, parameter-specific controllers.

Ease of Use and Confidence In Results

Large, high-resolution, transreflective display provides optimal viewing resolution in any lighting condition. Guided calibration procedures in 19 languages minimize complexity and reduce operator error. Password-protected SD card reader offers a simple solution for data download and transfer. Visual warning system provides critical alerts.

Wide Variety of Communication Options

Utilize two to five analog outputs to transmit primary and secondary values for each sensor, or integrate Hach sensors and analyzers into MODBUS RS232/RS485, Profibus® DP, and HART networks.



Password protected SD card reader offers a simple solution for data download and transfer, and sc200 and digital sensor configuration file duplication and backup.



Be Right™

Controller Comparison



Features	Previous Models		sc200™ Controller	Benefits
	sc100™ Controller	GLI53 Controller		
Display	64 x 128 pixels 33 x 66 mm (1.3 x 2.6 in.)	64 x 128 pixels 33 x 66 mm (1.3 x 2.6 in.)	160 x 240 pixels 48 x 68 mm (1.89 x 2.67 in.) Transreflective	<ul style="list-style-type: none"> Improved user interface—50% bigger Easier to read in daylight and sunlight
Data Management	IrDA Port/PDA Service Cable	N/A	SD Card Service Cable	<ul style="list-style-type: none"> Simplifies data transfer Standardized accessories/ max compatibility
Sensor Inputs	2 Max Direct Digital Analog via External Gateway	2 Max Analog Depending on Parameter	2 Max Digital and/or Analog with Sensor Card	<ul style="list-style-type: none"> Simplifies analog sensor connections Works with analog and digital sensors
Analog Inputs	N/A	N/A	1 Analog Input Signal Analog 4-20mA Card	<ul style="list-style-type: none"> Enables non-sc analyzer monitoring Accepts mA signals from other analyzers for local display Consolidates analog mA signals to a digital output
4-20 mA Outputs	2 Standard	2 Standard	2 Standard Optional 3 Additional	<ul style="list-style-type: none"> Total of five (5) 4-20 mA outputs allows multiple mA outputs per sensor input
Digital Communication	MODBUS RS232/RS485 Profibus DP V1.0	HART	MODBUS RS232/RS485 Profibus DP V1.0 HART 7.2	<ul style="list-style-type: none"> Unprecedented combination of sensor breadth and digital communication options

Choose from Hach's Broad Range of Digital and Analog Sensors

Parameter	Sensor	Digital or Analog
Ammonia	AMTAX™ sc, NH4D sc, AISE sc, AN-ISE sc	●
Chlorine	CLF10 sc, CLT10 sc, 9184 sc	●
Chlorine Dioxide	9185 sc	●
Conductivity	GLI 3400 Contacting, GLI 3700 Inductive	△
Dissolved Oxygen	LDO® Model 2, 5740 sc	●
Dissolved Oxygen	5500	△
Flow	U53, F53 Sensors	△
Nitrate	NITRATAX™ sc, NO3D sc, NISE sc, AN-ISE sc	●
Oil In Water	FP360 sc	●
Organics	UVAS sc	●
Ozone	9187 sc	●
pH/ORP	pHD	●
pH/ORP	pHD, pH Combination, LCP	△
Phosphate	PHOSPHAX™ sc	●
Sludge Level	SONATAX™ sc	●
Suspended Solids	SOLITAX™ sc, TSS sc	●
Turbidity	1720E, FT660 sc, SS7 sc, ULTRATURB sc, SOLITAX sc, TSS sc	●
Ultra Pure Conductivity	8310, 8311, 8312, 8315, 8316, 8317 Contacting	△
Ultra Pure pH/ORP	8362	△

● = Digital △ = Analog

Connect up to two of any of the sensors listed above, in any combination, to meet your application needs. The diagrams below demonstrate the potential configurations. Operation of analog sensors requires the controller to be equipped with the appropriate sensor module. Contact Hach Technical Support for help with selecting the appropriate module.

2 Channel Configurations



1 Channel Configurations



Specifications*

Dimensions (H x W x D)	5.7 in x 5.7 in x 7.1 in (144 mm x 144 mm x 181 mm)
Display	Graphic dot matrix LCD with LED backlighting, transreflective
Display Size	1.9 x 2.7 in. (48 mm x 68 mm)
Display Resolution	240 x 160 pixels
Weight	3.75 lbs. (1.70 kg)
Power Requirements (Voltage)	100 - 240 V AC, 24 V DC
Power Requirements (Hz)	50/60 Hz
Operating Temperature Range	-20 to 60 °C , 0 to 95% RH non-condensing
Analog Outputs	Two (Five with optional expansion module) to isolated current outputs, max 550 Ω , Accuracy: ± 0.1% of FS (20mA) at 25 °C, ± 0.5% of FS over -20 °C to 60 °C range Operational Mode: measurement or calculated value
Analog Output Functional Mode	Linear, Logarithmic, BI-linear, PID
Security Levels	2 password-protected levels
Mounting Configurations	Wall, pole, and panel mounting
Enclosure Rating	NEMA 4X/IP66
Conduit Openings	1/2 In NPT Conduit
Relay: Operational Mode	Primary or secondary measurement, calculated value (dual channel only) or timer

Relay Functions	Scheduler (Timer), Alarm, Feeder Control, Event Control, Pulse Width Modulation, Frequency Control, and Warning
Relays	Four electromechanical SPDT (Form C) contacts, 1200 W, 5 A
Communication	MODBUS RS232/RS485, PROFIBUS DPV1, or HART 7.2 optional
Memory Backup	Flash memory
Electrical Certifications	EMC CE compliant for conducted and radiated emissions: - CISPR 11 (Class A limits) - EMC Immunity EN 61326-1 (Industrial limits) Safety cETLus safety mark for: - General Locations per ANSI/UL 61010-1 & CAN/CSA C22.2. No. 61010-1 - Hazardous Location Class I, Division 2, Groups A,B,C & D (Zone 2, Group IIC) per FM 3600 / FM 3611 & CSA C22.2 No. 213 M1987 with approved options and appropriately rated Class I, Division 2 or Zone 2 sensors cULus safety mark - General Locations per UL 61010-1 & CAN/CSA C22.2. No. 61010-1 <i>*Subject to change without notice.</i>

Dimensions

Surface Mounting Dimensions



Panel Mounting Dimensions

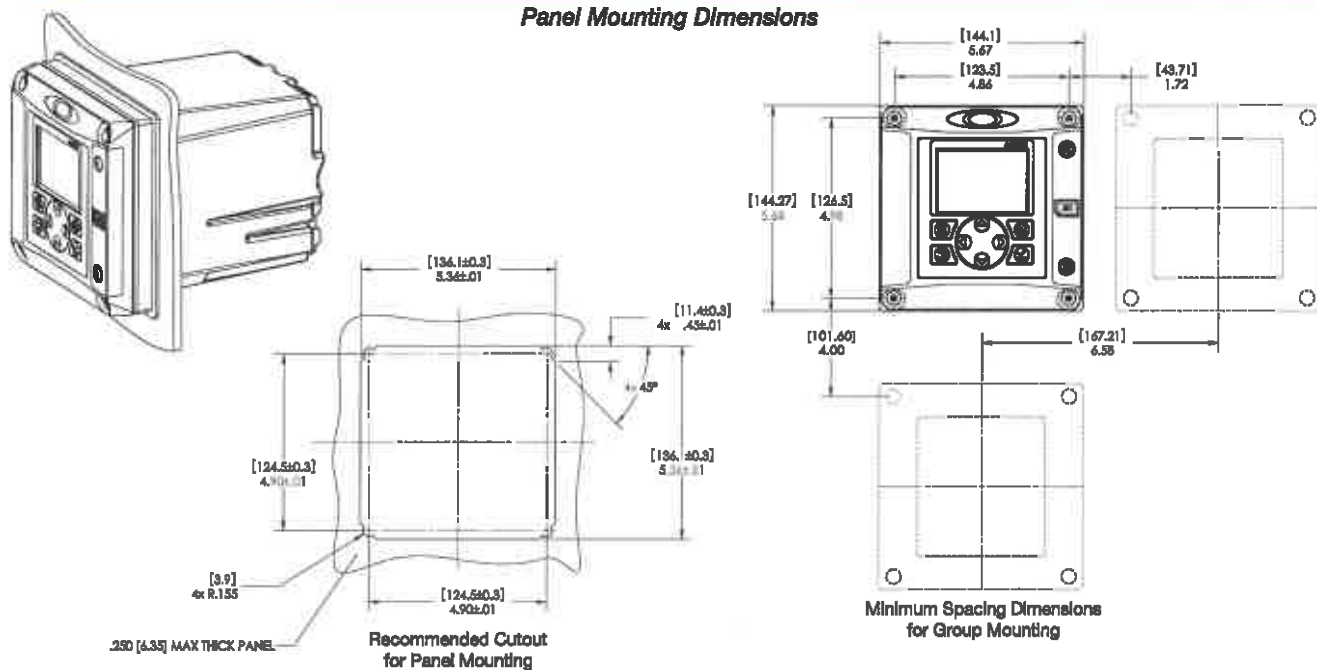

Top and Bottom Views

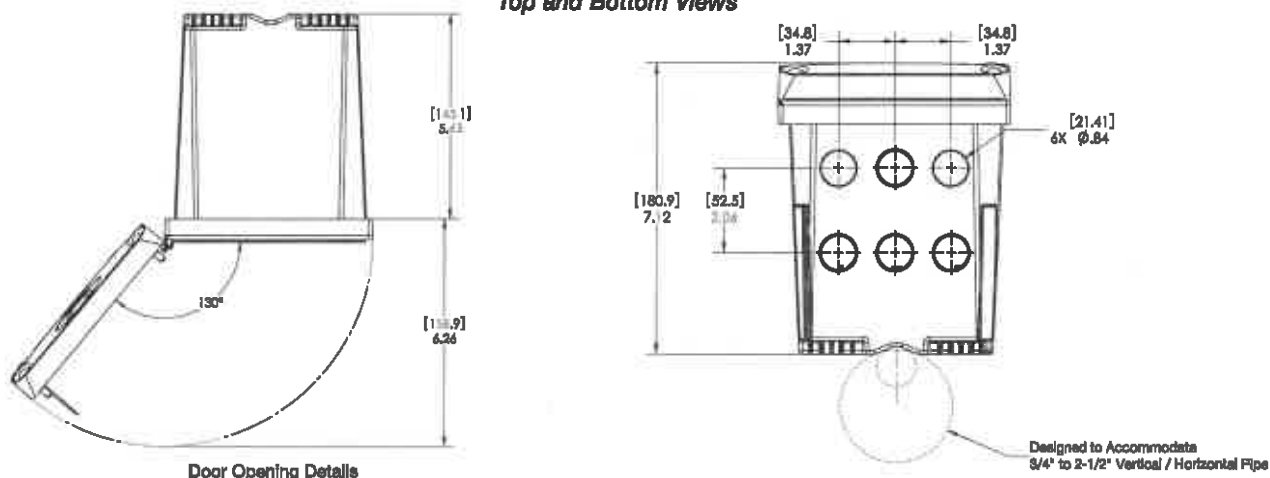

Ordering Information

sc200 for Hach Digital and Analog Sensors

LXV404.99.00552	sc200 controller, 2 channels, digital
LXV404.99.00502	sc200 controller, 1 channel, digital
LXV404.99.00102	sc200 controller, 1 channel, pH/DO
LXV404.99.00202	sc200 controller, 1 channel, Conductivity
LXV404.99.01552	sc200 controller, 2 channels, digital, Modbus RS232/RS485
LXV404.99.00112	sc200 controller, 2 channel, pH/DO

Note: Other Sensor combinations are available. Please contact Hach Technical Support or your Hach representative.

Note: Communication options (MODBUS, Profibus DPV1, and HART) are available. Please contact Hach Technical Support or your Hach representative.



sc200 for Ultrapure Sensors

9500.99.00602	sc200 controller, 1 channel, ultrapure conductivity
9500.99.00702	sc200 controller, 1 channel, ultrapure pH
9500.99.00662	sc200 controller, 2 channel, ultrapure conductivity
9500.99.00772	sc200 controller, 2 channel, ultrapure pH



Sensor and Communication Modules

9012900	Analog pH/ORP and DO module for GLI Sensors
9013000	Analog Conductivity module for GLI Sensors
9012700	Flow module
9012800	4-20 mA Input Module
9525700	Analog pH/ORP Module for Polymetron Sensors
9525800	Analog Conductivity Module for Polymetron Sensors
9013200	Modbus 232/485 Module
9173900	Profibus DP Module
9328100	HART Module
9334800	4-20 mA Output Module (Provides 3 additional mA Outputs)



Accessories

9220600	sc200 Weather and Sun Shield with UV Protection Screen
8809200	sc200 UV Protection Screen
9218200	SD card reader (USB) for connection to PC
9218100	4 GB SD card

HACH COMPANY World Headquarters: Loveland, Colorado USA

United States:	800-227-4224 tel	970-669-2932 fax	orders@hach.com
Outside United States:	970-669-3050 tel	970-461-3939 fax	int@hach.com

hach.com

LIT2665 Rev 7

K19 Printed in U.S.A.

©Hach Company, 2013. All rights reserved.

In the interest of improving and updating its equipment,

Hach Company reserves the right to alter specifications to equipment at any time.



Be Right™

HACH sc200 Controller and Hach LDO sensor Warranty

Hach Company warrants the sc200 Controller to the original purchaser against any defects that are due to faulty material or workmanship for a period of two years from date of shipment unless otherwise noted in the product manual. Hach Company warrants the LDO sensor for a period of three years to the original purchaser against any defects that are due to faulty material or workmanship for a period of three years from date of shipment unless otherwise noted in the product manual. Warranty is to the original purchaser against any defects that are due to faulty material or workmanship for the period noted above.

In the event that a defect is discovered during the warranty period, Hach Company agrees that, at its option, it will repair or replace the defective product or refund the purchase price excluding original shipping and handling charges. Any product repaired or replaced under this warranty will be warranted only for the remainder of the original product warranty period.

This warranty does not apply to consumable products such as chemical reagents; or consumable components of a product, such as, but not limited to, lamps and tubing. Contact Hach Company or your distributor to initiate warranty support. Products may not be returned without authorization from Hach Company.

Limitations

This warranty does not cover:

- Damage caused by acts of God, natural disaster, labor unrest, acts of war (declared or undeclared), terrorism, civil strife or acts of any governmental jurisdiction
- Damage caused by misuse, neglect, accident or improper application or installation
- Damage caused by any repair or attempted repair not authorized by Hach Company
- Any product not used in accordance with the instructions furnished by Hach Company
- Freight charges to return merchandise to Hach Company
- Freight charges on expedited or express shipment of warranted parts or product
- Travel fees associated with on-site warranty repair

This warranty contains the sole express warranty made by Hach Company in connection with its products. All implied warranties, including without limitation, the warranties of merchantability and fitness for a particular purpose, are expressly disclaimed.

Some states within the United States do not allow the disclaimer of implied warranties and if this is true in your state the above limitation may not apply to you. This warranty gives you specific rights, and you may also have other rights that vary from state to state.

This warranty constitutes the final, complete, and exclusive statement of warranty terms and no person is authorized to make any other warranties or representations on behalf of Hach Company.

Limitation of Remedies

The remedies of repair, replacement or refund of purchase price as stated above are the exclusive remedies for the breach of this warranty. On the basis of strict liability or under any other legal theory, in no event shall Hach Company be liable for any incidental or consequential damages of any kind for breach of warranty or negligence.