



LEXINGTON

Bid 94-2023 Pro Air Midwest Supplier Response

Event Information

Number: Bid 94-2023
Title: Breathing Air Compressor for Mobile Use
Type: Competitive Bid
Issue Date: 7/31/2023
Deadline: 8/14/2023 02:00 PM (ET)
Notes: ONLY ONLINE BIDS WILL BE ACCEPTED FOR THIS SOLICITATION. PRICING SHOULD BE SUBMITTED ON THE LINE ITEMS TAB ONLY. PRICING WITHIN SUBMITTALS WILL NOT BE ACCEPTED AND MAY MAKE YOUR BID NON-RESPONSIVE.

Contact Information

Contact: Jessica Allinder
Address: Procurement
Government Center Building
200 East Main Street
Lexington 40507
Fax: (859) 2583322
Email: jallinder@lexingtonky.gov

Pro Air Midwest Information

Contact: Bryan Goodall
Address: 6256 Legacy Ln
Ellettsville, IN 47429
Phone: (800) 245-0269
Email: bryan.goodall@proairmidwest.com
Web Address: www.proairmidwest.com

ONLY ONLINE BIDS WILL BE ACCEPTED! By submitting your response, you certify that you are authorized to represent and bind your company and that you agree to all bid terms and conditions as stated in the attached bid/RFP/RFQ/Quote/Auction documents.

Bryan Goodall

Signature

Submitted at 8/7/2023 12:29:45 PM (ET)

bryan.goodall@proairmidwest.com

Email

Response Attachments

Lexington 94-2023.pdf

Bid #94-2023 Signed Documentation.

Bid Attributes

1 Bid package

Have you completed and attached your bid package? This is a contractual agreement and required for all bids.

YES

Bid Lines

1 MAKO Model KOEM7H-E3 OEM Compressor Package or equivalent

Quantity: 1 UOM: Each Unit Price: Total:

Response Total: \$57,000.00



LEXINGTON

Lexington-Fayette Urban County Government

Lexington, Kentucky
Horse Capital of the World

Division of Procurement

Date of Issue: July 31, 2023

INVITATION TO BID #94-2023 Breathing Air Compressor for Mobile Use

Bid Opening Date: August 14, 2023

Bid Opening Time: 2:00 PM

Address: 200 East Main Street, Lexington, Kentucky 40507

Type of Bid: Firm Bid

Pre Bid Meeting: Month XX, 20XX

Pre Bid Time: X:XX xm

Address: XXXXXXXXXXXX Street

Sealed bids will ONLY be received online at <https://lexingtonky.ionwave.net/> until **2:00 PM**, prevailing local time on **08/14/2023**. Bids must be submitted/uploaded by the above-mentioned date and time.

Bids are to include all shipping, handling and associated fees to the point of delivery located at: XXXXXXXXXXXX, Lexington, KY 405XX

<input checked="" type="checkbox"/> Bid Specifications Met <u> </u> Exceptions to Bid Specifications. <i>Exceptions shall be itemized and attached to bid proposal submitted.</i>	<p style="text-align: center;">Check One:</p> <p style="text-align: center;">Proposed Delivery: 8-10 Months <u> </u> days after acceptance of bid.</p>
<p>Procurement Card Usage—The Lexington-Fayette Urban County Government may be using Procurement Cards to purchase goods and services and also to make payments. Will you accept Procurement Cards? <u> </u> Yes <input checked="" type="checkbox"/> No</p>	

Submitted by: Pro Air Midwest, LLC
Firm Name
6256 W Legacy Ln
Address
Ellettsville, IN, 47429
City, State & Zip

Bid must be signed:
(original signature)
Signature of Authorized Company Representative – Title
Bryan Goodall
Representative's Name (Typed or printed)
812-322-0547
Area Code - Phone – Extension Fax #
bryan.goodall@proairmidwest.com
E-Mail Address

The Affidavit in this bid must be completed before your firm can be considered for award of this contract.

AFFIDAVIT

Comes the Affiant, Bryan Goodall, and after being first duly sworn under penalty of perjury as follows:

1. His/her name is Bryan Goodall and he/she is the individual submitting the bid or is the authorized representative of Pro Air Midwest, LLC, the entity submitting the bid (hereinafter referred to as "Bidder")
2. Bidder will pay all taxes and fees, which are owed to the Lexington-Fayette Urban County Government at the time the bid is submitted, prior to award of the contract and will maintain a "current" status in regard to those taxes and fees during the life of the contract.
3. Bidder will obtain a Lexington-Fayette Urban County Government business license, if applicable, prior to award of the contract.
4. Bidder has authorized the Division of Procurement to verify the above-mentioned information with the Division of Revenue and to disclose to the Urban County Council that taxes and/or fees are delinquent or that a business license has not been obtained.
5. Bidder has not knowingly violated any provision of the campaign finance laws of the Commonwealth of Kentucky within the past five (5) years and the award of a contract to the Bidder will not violate any provision of the campaign finance laws of the Commonwealth.
6. Bidder has not knowingly violated any provision of Chapter 25 of the Lexington-Fayette Urban County Government Code of Ordinances, known as "Ethics Act."
7. Bidder acknowledges that "knowingly" for purposes of this Affidavit means, with respect to conduct or to circumstances described by a statute or ordinance defining an offense, that a person is aware or should have been aware that his conduct is of that nature or that the circumstance exists.

Further, Affiant sayeth naught. [Signature]

STATE OF INDIANA

COUNTY OF MONROE

The foregoing instrument was subscribed, sworn to and acknowledged before me by BRYAN GOODALL on this the 4th day of AUGUST, 2023

My Commission expires: MAY 27, 2027

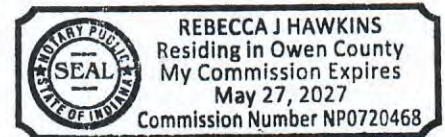

Rebecca J Hawkins
NOTARY PUBLIC, STATE AT LARGE

Please refer to Section II. Bid Conditions, Item "U" prior to completing this form.

I. GREEN PROCUREMENT

A. ENERGY

The Lexington-Fayette Urban County Government is committed to protecting our environment and being fiscally responsible to our citizens.

The Lexington-Fayette Urban County Government mandates the use of Energy Star compliant products if they are available in the marketplace (go to www.Energystar.gov). If these products are available, but not submitted in your pricing, your bid will be rejected as non-compliant.

ENERGY STAR is a government program that offers businesses and consumers energy-efficient solutions, making it easy to save money while protecting the environment for future generations.

Key Benefits

These products use 25 to 50% less energy
Reduced energy costs without compromising quality or performance
Reduced air pollution because fewer fossil fuels are burned
Significant return on investment
Extended product life and decreased maintenance

B. GREEN SEAL CERTIFIED PRODUCTS

The Lexington-Fayette Urban County Government is also committed to using other environmentally friendly products that do not negatively impact our environment. Green Seal is a non-profit organization devoted to environmental standard setting, product certification, and public education.

Go to www.Greenseal.org to find available certified products. These products will have a reduced impact on the environment and on human health. The products to be used must be pre-approved by the LFUCG prior to commencement of any work in any LFUCG facility. If a Green Seal product is not available, the LFUCG must provide a signed waiver to use an alternate product. Please provide information on the Green Seal products being used with your bid response.

C. GREEN COMMUNITY

The Lexington-Fayette Urban County Government (LFUCG) serves as a principal, along with the University of Kentucky and Fayette County Public Schools, in the Bluegrass Partnership for a Green Community. The Purchasing Team component of the Partnership collaborates on economy of scale purchasing that promotes and enhances environmental initiatives. Specifically, when applicable, each principal is interested in obtaining best value products and/or services which promote environment initiatives via solicitations and awards from the other principals.

If your company is the successful bidder on this Invitation For Bid, do you agree to extend the same product/service pricing to the other principals of the Bluegrass Partnership for a Green Community (i.e. University of Kentucky and Fayette County Schools) if requested?

Yes No

II. Bid Conditions

- A. No bid may be withdrawn for a period of sixty (60) days after the date and time set for opening.
- B. No bid may be altered after the date and time set for opening. In the case of obvious errors, the Division of Procurement may permit the withdrawal of a bid. The decision as to whether a bid may be withdrawn shall be that of the Division of Procurement.
- C. Acceptance of this proposal shall be enactment of an Ordinance by the Urban County Council.

Executive Order No. 11246 on Nondiscrimination under Federal contract prohibits employment discrimination by contractor and sub-contractor doing business with the Federal Government or recipients of Federal funds. This order was later amended by Executive Order No. 11375 to prohibit discrimination on the basis of sex.

Section 503 of the Rehabilitation Act of 1973 states:

The Contractor will not discriminate against any employee or applicant for employment because of physical or mental disability.

Section 2012 of the Vietnam Era Veterans Readjustment Act of 1973 requires Affirmative Action on behalf of disabled veterans and veterans of the Vietnam Era by contractors having Federal contracts.

Section 206(A) of Executive Order 12086, Consolidation of Contract Compliance Functions for Equal Employment Opportunity, states:

The Secretary of Labor may investigate the employment practices of any Government contractor or sub-contractor to determine whether or not the contractual provisions specified in Section 202 of this order have been violated.

The Lexington-Fayette Urban County Government practices Equal Opportunity in recruiting, hiring and promoting. It is the Government's intent to affirmatively provide employment opportunities for those individuals who have previously not been allowed to enter into the mainstream of society. Because of its importance to the local Government, this policy carries the full endorsement of the Mayor, Commissioners, Directors and all supervisory personnel. In following this commitment to Equal Employment Opportunity and because the Government is the benefactor of the Federal funds, it is both against the Urban County Government policy and illegal for the Government to let contracts to companies which knowingly or unknowingly practice discrimination in their employment practices. Violation of the above mentioned ordinances may cause a contract to be canceled and the contractors may be declared ineligible for future consideration.

Please sign this statement in the appropriate space acknowledging that you have read and understand the provisions contained herein. Return this document as part of your application packet.

Bidders

I/We agree to comply with the Civil Rights Laws listed above that govern employment rights of minorities, women, veteran status, disability and age.



Signature



Name of Business

21. If any term or provision of this bid contract shall be found to be illegal or unenforceable, the remainder of the contract shall remain in full force and such term or provision shall be deemed stricken.



Signature



Date

WORKFORCE ANALYSIS FORM

Name of Organization: _____

Pro Air Midwest

Categories	Total	White (Not Hispanic or Latino)		Hispanic or Latino		Black or African-American (Not Hispanic or Latino)		Native Hawaiian and Other Pacific Islander (Not Hispanic)		Asian (Not Hispanic or Latino)		American Indian or Alaskan Native (not Hispanic or Latino)		Two or more races (Not Hispanic or Latino)		Total	
		M	F	M	F	M	F	M	F	M	F	M	F	M	F	M	F
Administrators	1		1														1
Professionals	1	1															1
Superintendents																	
Supervisors	1	1															1
Foremen																	
Technicians	6	6															6
Protective Service																	
Para-Professionals																	
Office/Clerical																	
Skilled Craft																	
Service/Maintenanc																	
Total:																	

Prepared by: Bryan Goodall President
 (Name and Title)

Date: 8, 4, 23
 Revised 2015-Dec-15



LEXINGTON

LFUCG MWDBE PARTICIPATION FORM
Bid/RFP/Quote Reference # 94.2023

The MWDBE and/or veteran subcontractors listed have agreed to participate on this Bid/RFP/Quote. If any substitution is made or the total value of the work is changed prior to or after the job is in progress, it is understood that those substitutions must be submitted to Procurement for approval immediately. **Failure to submit a completed form may cause rejection of the bid.**

MWDBE Company, Name, Address, Phone, Email	MBE WBE or DBE	Work to be Performed	Total Dollar Value of the Work	% Value of Total Contract
1.				
NONE				
2.				
No SubContractors will be used				
3.				
by Pro Aiz Midwest				
4.				

The undersigned company representative submits the above list of MWDBE firms to be used in accomplishing the work contained in this Bid/RFP/Quote. Any misrepresentation may result in the termination of the contract and/or be subject to applicable Federal and State laws concerning false statements and false claims.

Pro Aiz Midwest
Company
8-4-23
Date

Bryan Goodall
Company Representative
President
Title

18. The contractor agrees and certifies that all activities performed pursuant to any Agreement entered as a result of the contractor's bid, and all goods and services procured under that Agreement, shall comply with 2 C.F.R. § 200.216 (Prohibition on certain telecommunications and video surveillance services and equipment) and 2 C.F.R. 200 § 200..323 (Procurement of recovered materials), to the extent either section is applicable.

19. If this bid involves construction work for a project totaling \$10 million or more, then the contractor further agrees that all laborers and mechanics, etc., employed in the construction of the public facility project assisted with funds provided under this Agreement, whether employed by contractor, or contractor's contractors, or subcontractors, shall be paid wages complying with the Davis-Bacon Act (40 U.S.C. 3141-3144). Contractor agrees that all of contractor's contractors and subcontractors will pay laborers and mechanics the prevailing wage as determined by the Secretary of Labor and that said laborers and mechanics will be paid not less than once a week. The contractor agrees to comply with the Copeland Anti- Kick Back Act (18 U.S.C. § 874) and its implementing regulations of the U.S. Department of Labor at 29 CFR part 3 and part 5. The contractor further agrees to comply with the applicable provisions of the Contract Work Hours and Safety Standards Act (40 U.S.C. Section 327-333), and the applicable provisions of the Fair Labor Standards Act of 1938, as amended (29 U.S.C. et seq.). Contractor further agrees that it will report all suspected or reported violations of any of the laws identified in this paragraph to LFUCG.

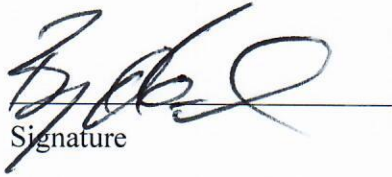

Signature

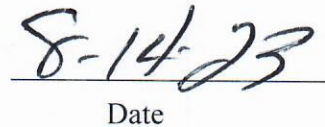

Date

Standard Remote CMM Panel

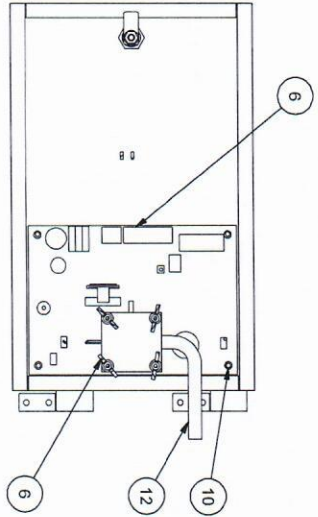

SECTION A-A

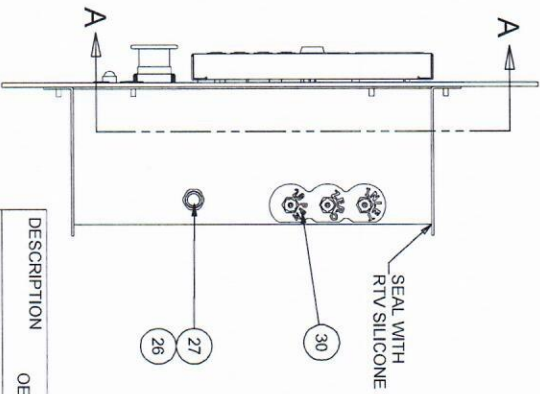
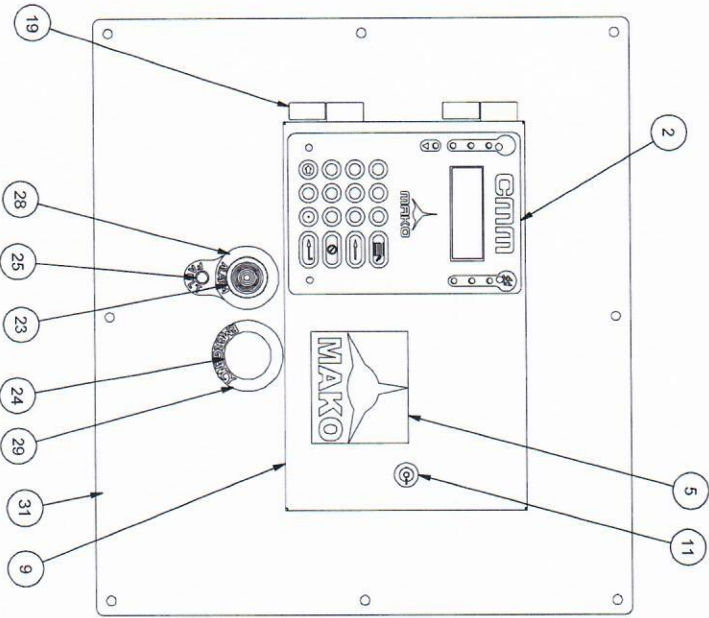
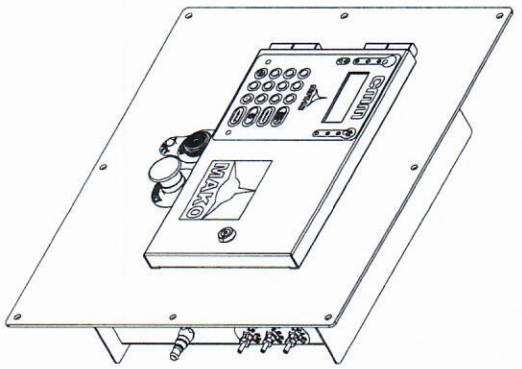

ITEM	QTY	PART NO.	DESCRIPTION
1	5	0031492-LD3	BLOCK TERMINAL DBL DECK
2	1	0030CMM08319	OVERLAY CMM W/MEMBRANE
3	1	0030DR1-6	DIN-RAIL 6"LG
4	2	0030EN10300226	EL-TRELEC - END STOPS
5	1	0031MAKOS-MINI	LABEL-MAKO SHARK MINI
6	1	003MEC-4	BOARD CMM
7	3	003MEC-TUBQDF	BULKHEAD TB CONNECTOR 1/8 F-MALE NYLON
8	3	003MEC-TUBODM	BULKHEAD TB CONNECTOR 1/8 MALE NYLON
9	1	008PUR09011	WELD DOOR CMM
10	4	003E437	RISER PC BOARD 8-32 X 5/8 NYLON
11	1	003E35675	LATCH - TOOL OPERATED STYLE SMALL
12	10"	003E440-6	HOSE RED RUBBER 1/4" 10' LONG
13	2	003E416	RELAY CONTROL MEC 24V
14	1	003E401	TEE BARBED 1/8 AIR LOGIC PLASTIC
15	1	003E403	RESTRICTOR 1/8 PLASTIC CO
16	3	003E408	SOLENOID 10MM 3WAY NC 24VDC
17	4	003E407	BARB HOSE X27-2
18	1	003E405	MANIFOLD 3 STAGE
19	2	003961050050	HINGE - IN-LINE - LIFT OFF
20	1	TRL09810	CMM BACK BOX WELDMENT
21	3	003E404	HARNES. SOLENOID, MEC
22	60"	003E406	TUBE-1/8 PARKER CLEAR
23	1	003E0164	ALARM - AUDIBLE 12VOLT
24	1	003E125	SWTCH - E-STOP TWIST 2 POSITION
25	1	003E0242	LIGHT PILOT 10MM 24VDC RED
26	1	bb1082934	H3 - CMM PANEL RECEPTACLE
27	1	bb1082936	H3 - CMM PANEL COROSET
28	1	bb1082890	H3 - ALARM & FAULT LIGHT LABEL - CMM
29	1	bb1082891	H3 - E-STOP LABEL - CMM
30	1	bb1082892	H3 - PORT LABELS - CMM
31	1	BB1083081	H3 - CMM/PANEL ASSY

DESCRIPTION	OEM CMM PANEL MOUNT ASSY	PRODUCT LINE	PART NO.	SCALE	SIZE	DRAWN	DATE	APPROVED
		OEM	WMM10308	NONE	B	KL	11/12/2008	JD
				SHT	QTY REQ	REV BY	REV DATE	EON #
				1 OF 3	1	TXR	8/18/2011	1061399
				MATL				REV
								B



MAKO COMPRESSORS
100 GARDNER PARK
PTC, GA 30286
(770)632-5000 PH
(770)632-9017 FX
WWW.MAKOCOMPRESSORS.COM

Unless otherwise specified
All Dimensions ± .0025"
Angular Tolerance ± 0.5°
All Dimensions in Inches
Do Not Scale This Drawing
Break all sharp edges
THIRD ANGLE PROJECTION

This document contains confidential information and is the property of Mako Compressors, LLC. It is to be used only for the purposes intended. No part of this document may be reproduced, stored in a retrieval system, or transmitted in any form or by any means, electronic, mechanical, photocopying, recording, or by any information storage and retrieval system, without the prior written permission of Mako Compressors, LLC. © 2009

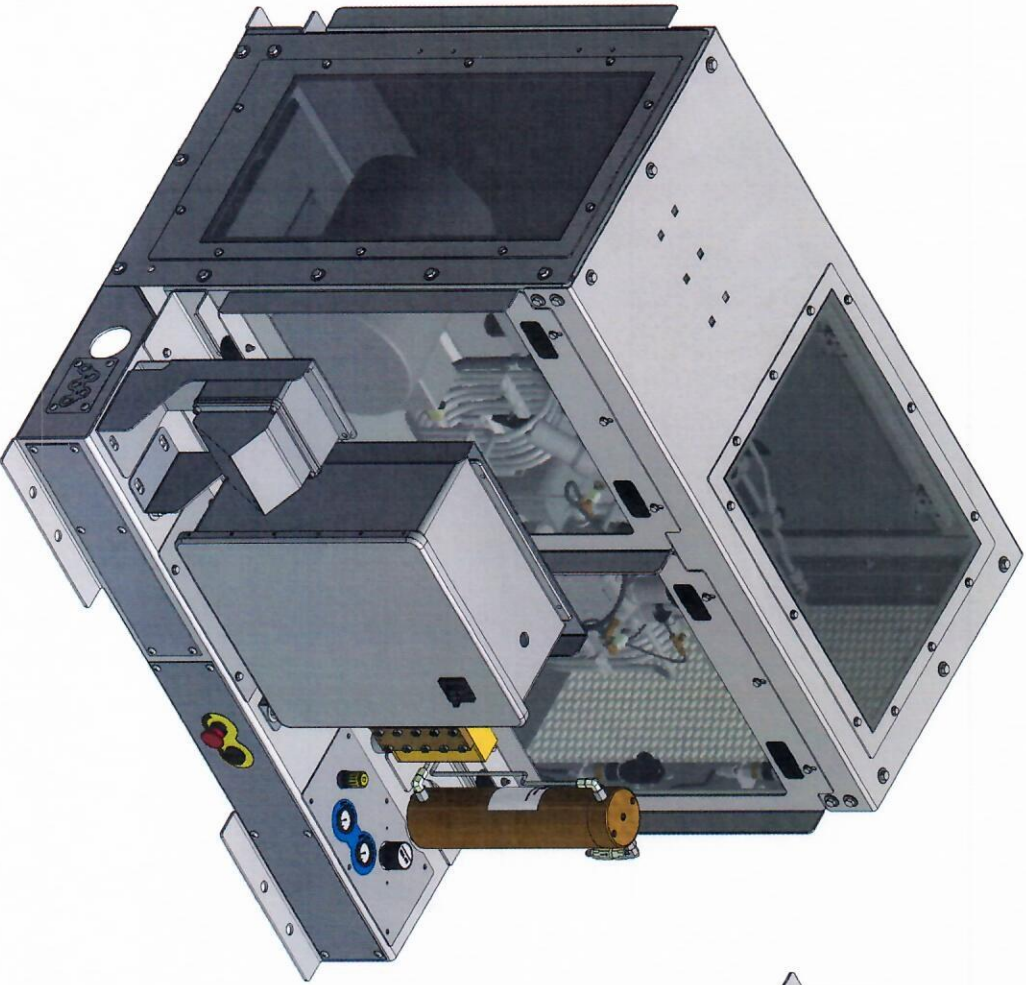
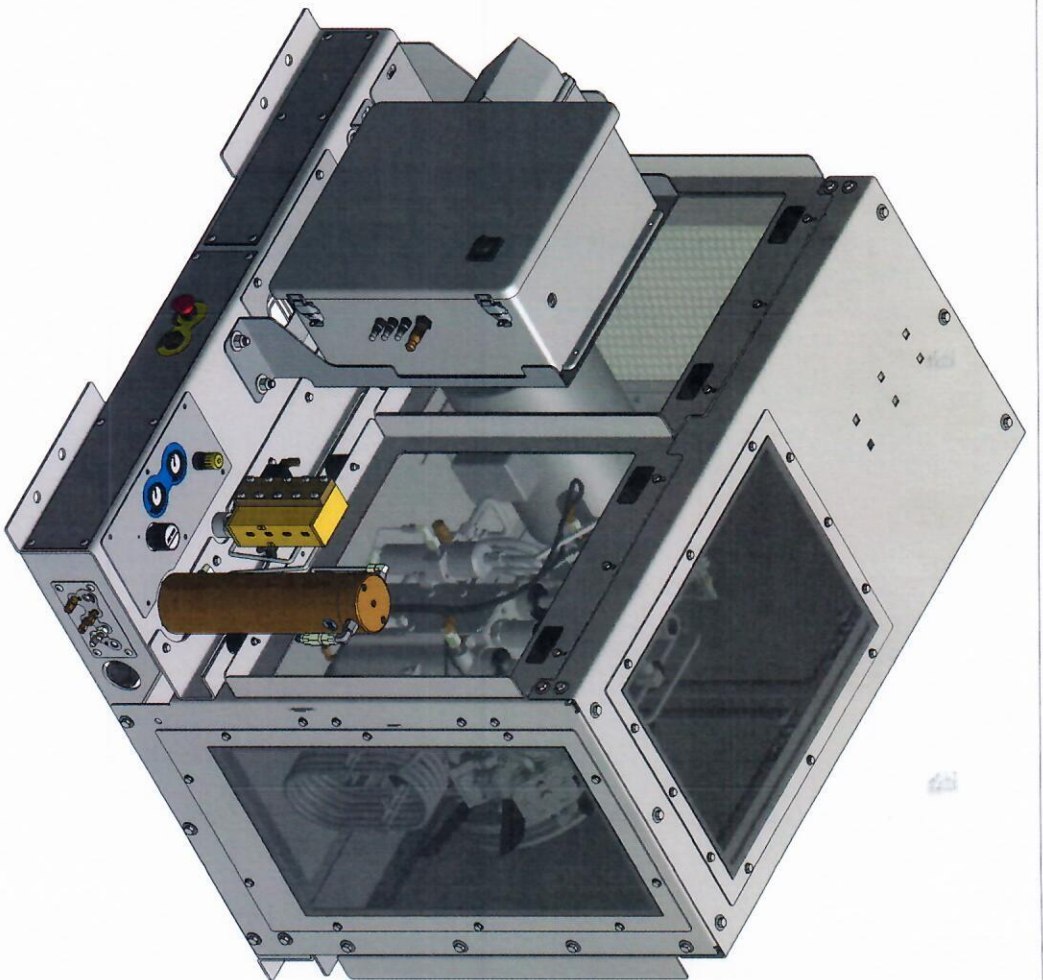

DESCRIPTION OEM HORZ 7H 15HP 20.7C 3230160
SOFT-REM

PRODUCT LINE OEM
PART NO. MKB171H0M3238-S003



MAKO COMPRESSORS
100 Gardner Park
Peachtree City, GA 30088
(770) 532-2000 P1
www.makocompressors.com

Unless otherwise specified:
All Dimensions ±.0025"
Angular Tolerance ±.05°
All Dimensions in Inches
Fit per ASME Y14.5
Break all sharp edges

SCALE	SIZE	DRAWN	DATE	APPROVED
NONE	0	TXR	2/11/2015	JCD
1 OF 2	1	REV BY	REV DATE	ECN #
WALT				REV A

THIRD ANGLE PROJECTION (N/A)

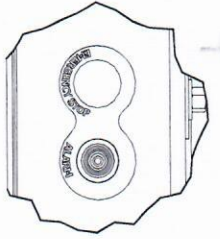

DETAIL D
SCALE 1/2
E-STOP & AUDIBLE ALARM

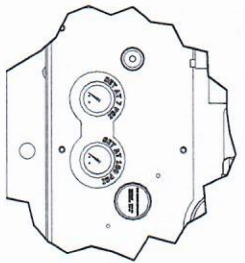
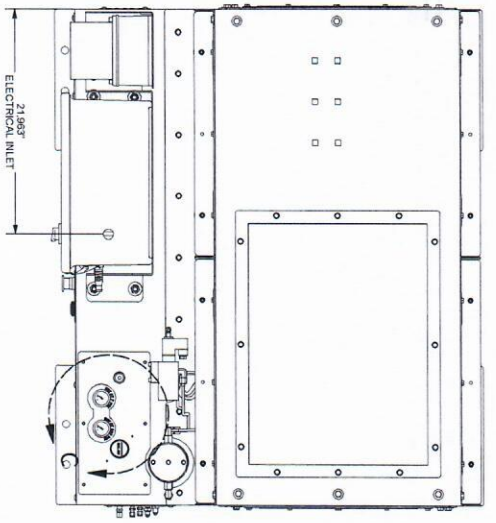

DETAIL C
SCALE 1/2
AIR INSTRUMENTS
& CO SAMPLE

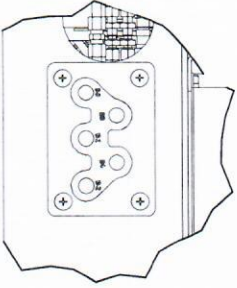
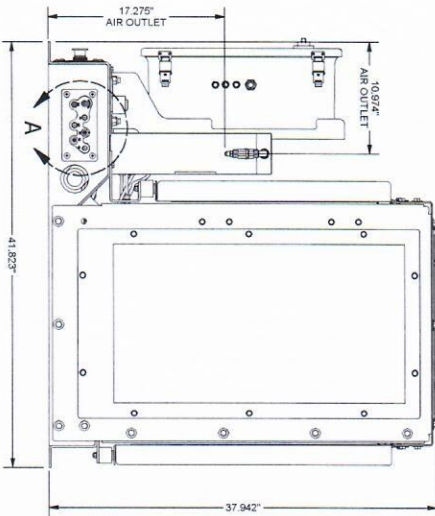
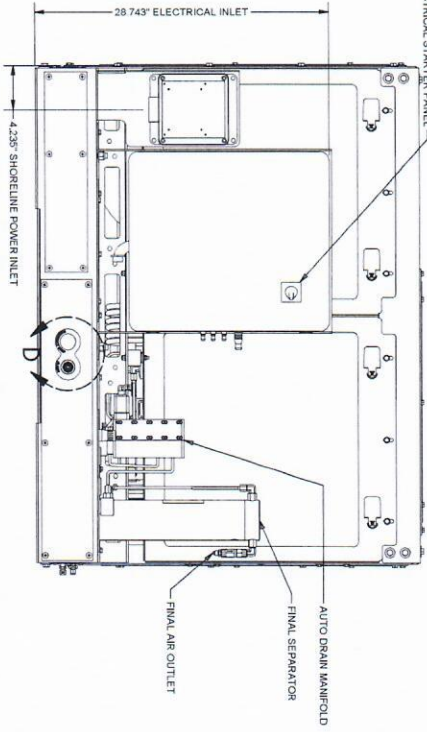
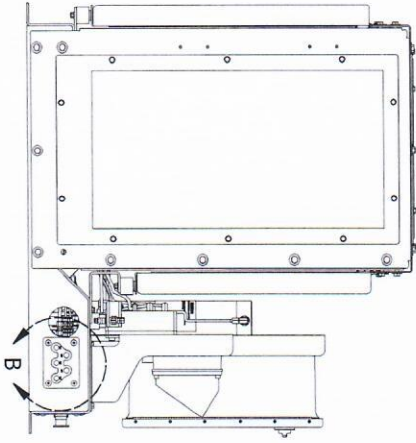

DETAIL B
SCALE 1/2
OPTIONAL AIR OUTLET

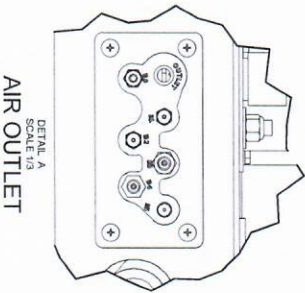

DETAIL A
SCALE 1/2
AIR OUTLET

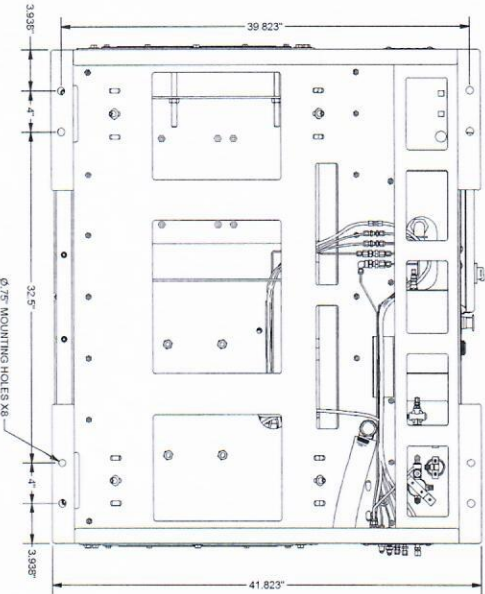

DESCRIPTION OEM HORIZ 7H 15HP 20 TC 3/23/080
SOFT-REM
PRODUCT LINE OEM
PART NO. MKB177HON3236-S003



MRKO COMPRESSORS
Peachtree City, GA 30089
(770) 832-5000 FAX
(770) 832-5000 FAX
www.mrko.com

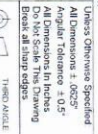

SCALE	SIZE	DRAWN	DATE	APPROVED
NONE	C	TRR	2/17/2015	JCD
SHT	REV C	REV BY	REV DATE	ECN #
2 OF 2	REV A	REV BY	REV DATE	ECN #
MATL				REV
		(N/A)		A

PIERCE MANUFACTURING, INC. JOB0505653
 AUTO DRAIN MUFFLER RESERVOIR



WAKO COMPRESSORS INC.

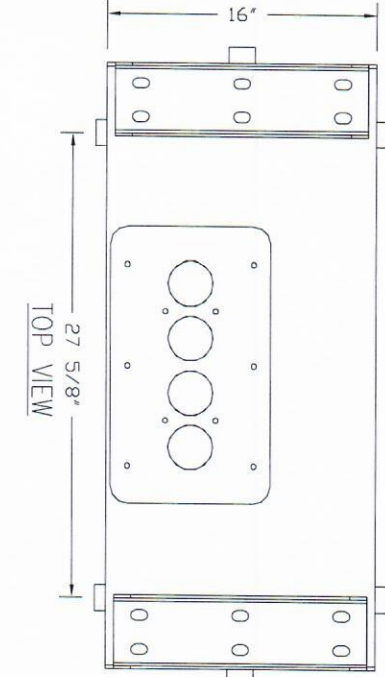

TOP VIEW

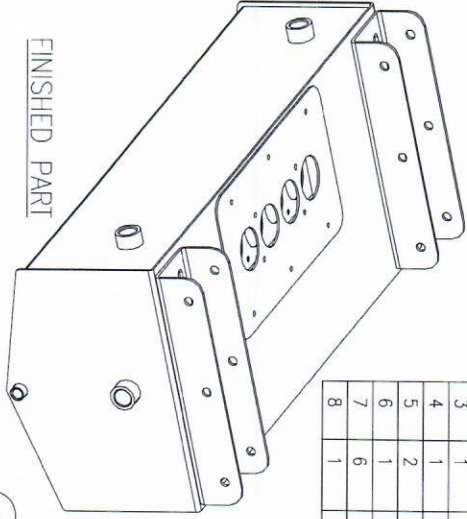

FINISHED PART

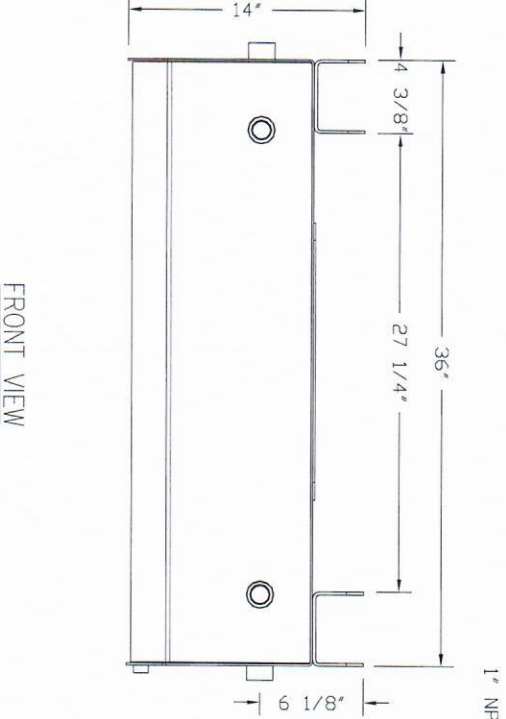

FRONT VIEW

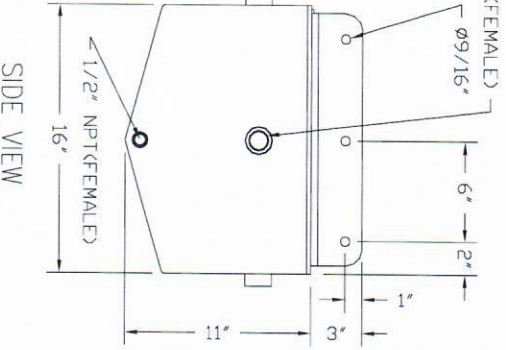

SIDE VIEW

ITEM QUAN		SIZE (BLANK)	BILL OF MATERIAL STOCK MATERIAL	DESCRIPTION
1	1	35 5/8" X 32 11/16"	11ga (0.119") STEEL SHEET	RS 44 05071 0 dwg
2	1	57 9/16" X 16"	11ga (0.119") STEEL SHEET	RS 44 05069 0 dwg
3	1	5 5/16" X 13 3/4"	18ga (0.060") STEEL SHEET	RC 82 00017 1 dwg
4	1	16 1/2" X 9 1/2"	11ga (0.119") STEEL SHEET	RC 44 05072 0 dwg
5	2	15" X 9 11/16"	3/16" (0.188") STEEL SHEET	RB 44 05073 0 dwg
6	1	-	SILENCER	003X0232
7	6	-	1" NPT COUPLING	003Z0402
8	1	-	1/2" NPT COUPLING	003Z0403

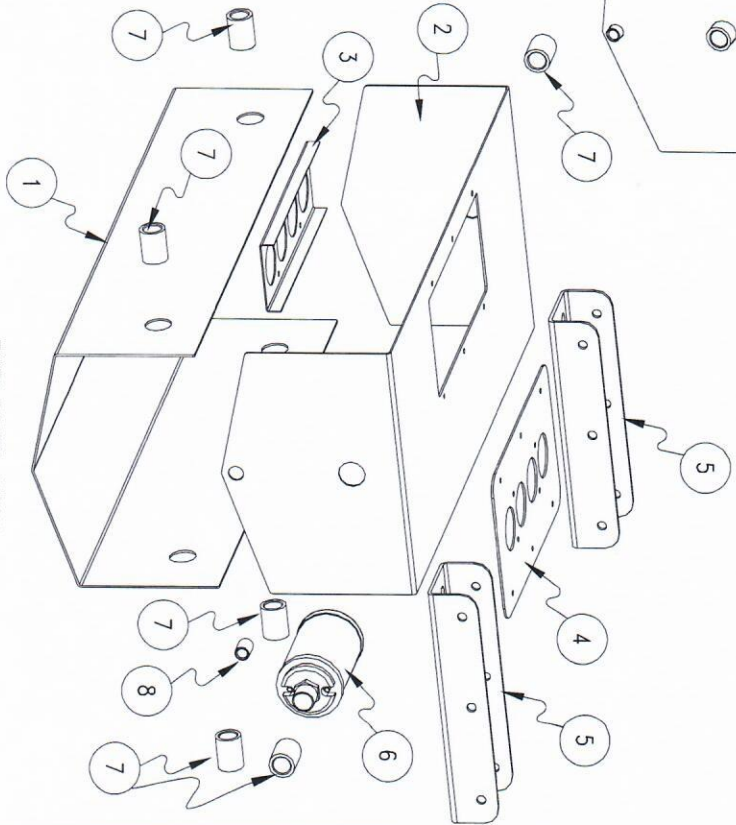

EXPLODED VIEW

DRAWING NUMBER AND/OR FILE: H:\CUSTOM\PIERCE\JOB0505653\ RA0505000.DWG
 SCALE: 1/8" SIZE
 DRAWN BY: K. M. BAGGETT DATE: MARCH 12, 2001
 APPROVED BY: S. M. BAGGETT PART NO. RA - 05050 [0]
 1634 SW 17th STREET, OCALA, FLORIDA 34474 TELEPHONE (352) 732-2268 FAX (352) 732-7873