

LEXINGTON-FAYETTE URBAN COUNTY GOVERNMENT CONTRACT CHANGE ORDER Page 1 of 2	Date:	November 10, 2016
	Project:	Fire Station #2 Replacement
	Location:	Lexington
To (Contractor): Olympic Construction, LLC 216 Bromme Drive Nicholasville, KY 40356	Contract No.	013-2016
	Original Contract Amt.	\$4,618,900.00
	Cumulative Amount of Previous Change Orders	-\$919.57
	Percent Change - Previous Change Orders	-0.02%
	Total Contract Amount Prior to this Change Order	\$4,617,980.43
	Change Order No.	5

You are hereby requested to comply with the following changes from the contract plans and specification;

Current Change Order

Item No.	Description of changes-quantities, unit prices, change in completion date, etc.	Decrease in contract price	Increase in contract price
1	Extend patio wall to 7'-4" tall per PR 07		\$9,840.70
2	Modify existing rails at hose tower per PR 07		\$1,820.00
3	Allowable overhead of 10%		\$1,166.07
	Total decrease	\$0.00	
	Total increase		\$12,826.77
	Net Amount of this Change Order	\$12,826.77	
	New Contract Amount Including this Change Order	\$4,630,807.20	
	Percent Change - This Change Order		0.28%
	Percent Change - All Change Orders		0.26%

The time provided for the completion in the contract and all provisions of the contract will apply hereto.

Recommended by	<i>Jayce Thomas</i>	(Project Manager)	Date	11/10/2016
Accepted by	<i>[Signature]</i>	(Contractor)	Date	11/11/2016
Approved by	<i>[Signature]</i>	(Director)	Date	11-11-16
Approved by	<i>[Signature]</i>	(Commissioner)	Date	11-11-16
Approved by	<i>[Signature]</i>	(Mayor or CAO)	Date	11/14/16

JUSTIFICATION FOR CHANGE

PROJECT: Fire Station #2 Replacement

CONTRACT NO. 013-2016

CHANGE ORDER NO. 5

1. Necessity for change: Extending the patio wall during construction in lieu of post construction will be more efficient and funds are available. Modifying rails at hose tower will create a training opportunity for the firefighters.
2. Is proposed change an alternate bid? ___ Yes X No
3. Will proposed change alter the physical size of the project? ___ Yes X No
If "Yes", explain.
4. Effect of this change on other prime contractors: N/A
5. Has consent of surety been obtained? ___ Yes X Not Necessary
6. Will this change affect expiration or extent of insurance coverage? ___ Yes X No
If "Yes", will the policies be extended? ___ Yes ___ No
7. Effect on operation and maintenance costs: N/A
8. Effect on contract completion date: 0 working days

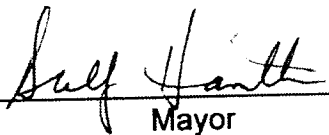

Mayor

11/14/16

Date



**BRANDSTETTER
CARROLL INC**

1000 BROADVIEW AVENUE, SUITE 1000, CINCINNATI, OH 45202

2360 Chauvin Dr
LEXINGTON
KY 40517
859.268.1933
FX: 859.268.3341

308 East 8th St
CINCINNATI
OH 45202
513.651.4224
FX: 513.651.0147

1220 West 6th St
Suite 300
CLEVELAND
OH 44113
216.241.4480
FX: 216.736.7155

17300 Preston Rd
Suite 310
DALLAS
TX 75252
469.941.4926
FX: 469.941.4112

Work Changes Proposal Request No. 7

Project: 13117 Lexington Replacement Fire Station No. 2
City Job No. 161-2015/038-2016

To: Olympic Construction
216 Brome Dr.
Nicholasville, KY 40356

From: Brandstetter Carroll Inc.
2360 Chauvin Drive
Lexington, KY 40517

Date of Original Issuance: October 10, 2016

Response Due: ASAP

THIS IS NOT A CHANGE ORDER, CONSTRUCTION CHANGE DIRECTIVE, OR A DIRECTION TO PROCEED WITH THE WORK DESCRIBED IN THE PROPOSED MODIFICATION.

Per Field Review with Chief Hoskins, provide itemized pricing for the following items:

1. Extend Patio Wall to 7'-4" tall with cast stone cap similar to dumpster screen wall detail so top of cap is at the top of the window and door head. It should be a continuation of the Dayroom Wall so utilize the brick size and color shown on the elevation on A-202. Provide a weir at the base of both walls as shown in attached PR 7.3.
2. Modify existing rails at Training Tower to provide Training window as shown in the attached PR 7.1 and PR 7.2.

Attachments: PR 7.1 – PR 7.2 – PR 7.3

Submitted by:

Eric M. Chambers, AIA, CID, CDT, LEED GA
Associate

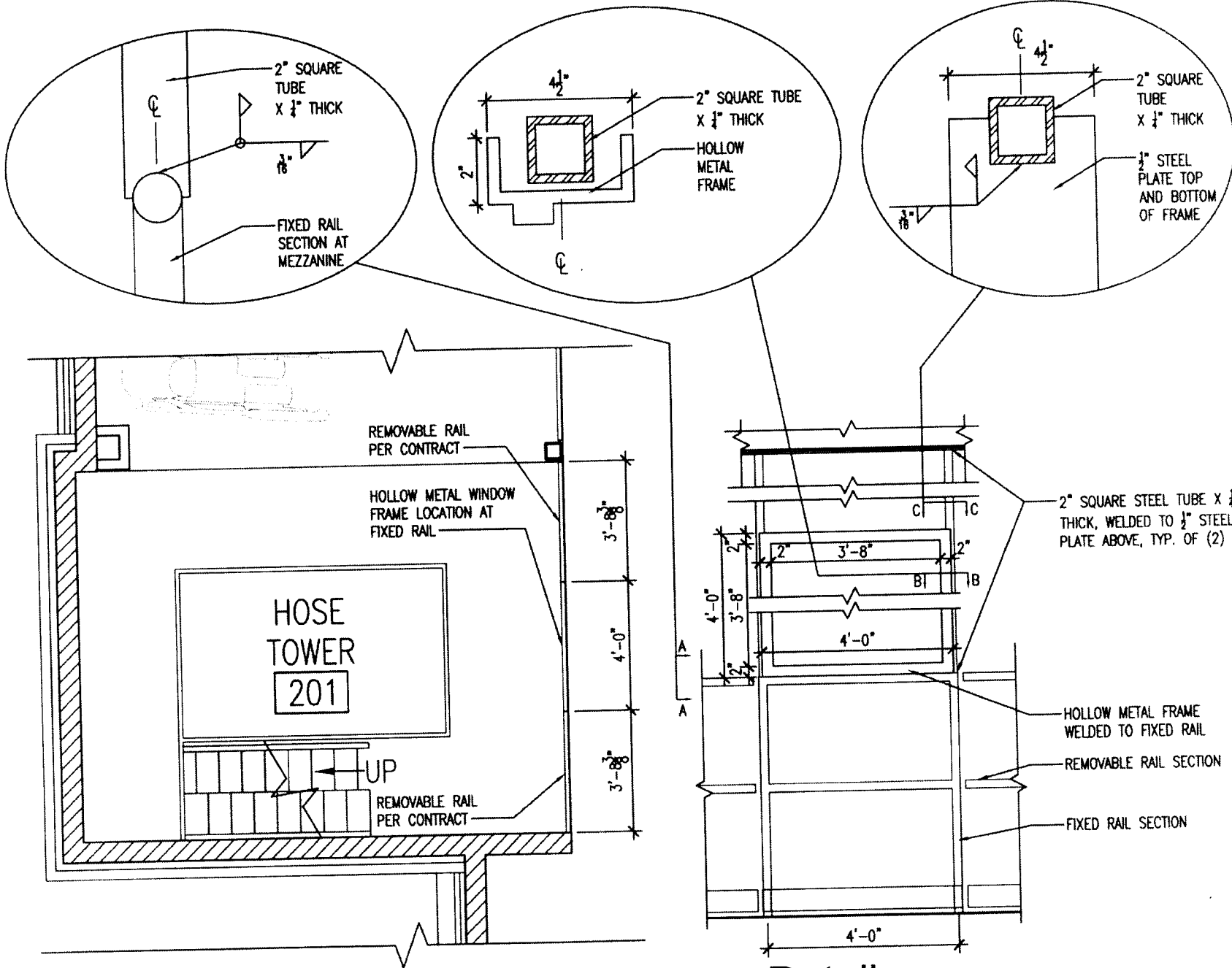

A1 Mezzanine Floor Plan
1/4" = 1'-0"

B1 Detail
1/2" = 1'-0"

PR 7.1

**BRANDSTETTER
CARROLL INC**
ARCHITECTS ENGINEERS PLANNERS

Lexington Cincinnati Cleveland Dallas

Lexington Replacement Fire Station No. 2
1276 Eastland Drive, Lexington, KY 40505

Window Frame @ Training Tower

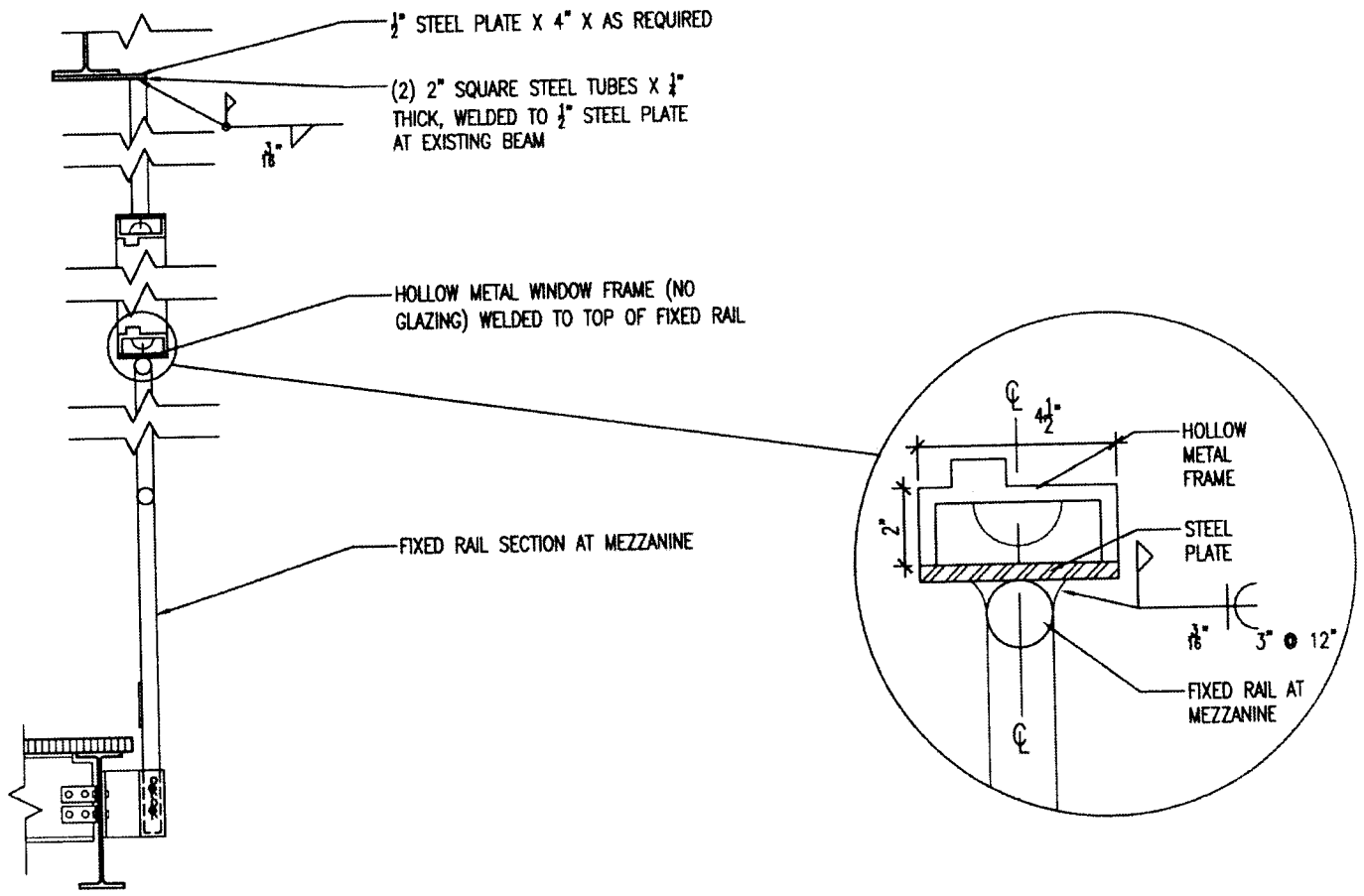

A1 Detail
 $\frac{3}{4}$ " = 1'-0"

13117 10-06-16

A-504

Lexington Replacement Fire Station No. 2
 1276 Eastland Drive, Lexington KY 40505

Window Frame @ Training Tower



**BRANDSTETTER
 CARROLL INC**
 ARCHITECTS ENGINEERS PLANNERS

1276 EASTLAND DRIVE
 LEXINGTON, KY 40505
 Lexington Cincinnati Cleveland Dallas

PR 7.2

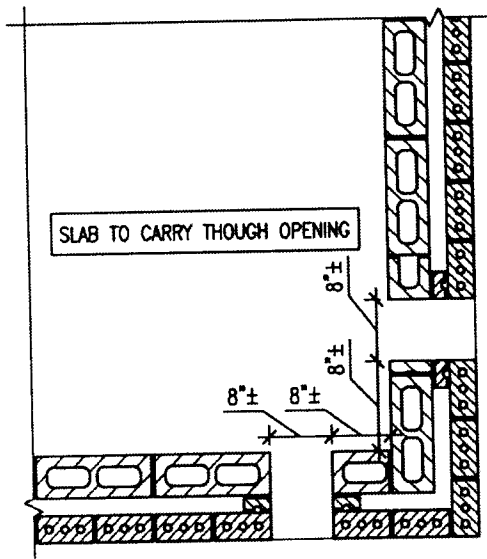

**Enlarged
Outdoor Patio Plan**

A1
1/2"=1'-0"

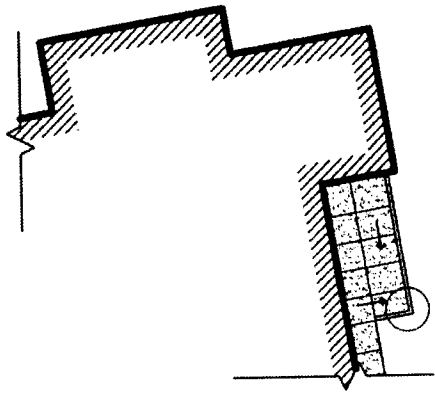

Outdoor Patio Plan

B2
1/32"=1'-0"

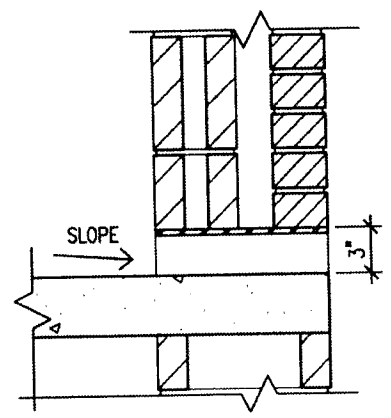

Weir Section

A2
1"=1'-0"

13117 10-10-16

Lexington Replacement Fire Station No. 2
1276 Eastland Drive, Lexington KY 40505

Outdoor Patio Wall



**BRANDSTETTER
CARROLL INC**
ARCHITECTS, ENGINEERS, PLANNERS
3882 POLARIS DRIVE, SUITE 100, #200
LEXINGTON, KY 40502-1000
Lexington Cincinnati Cleveland Dallas

PR 7.3



OLYMPIC CONSTRUCTION, LLC

120 MacArthur Court
Nicholasville, KY 40356

Office 859-533-5723 Fax 859-881-1295
victor@olympiconstruction.com

Lexington Fire Station No. 2 Change Order #9 Proposal Request 7

Retaining wall 33' long x 7'4" high = 242 sf (Item 1 of PR 7)

1) Block labor and materials. Unit Price \$15.90 x 242	\$3,847.80
2) Capitol Cast Stone materials 40 LF x \$50 = \$2,000 + \$100 freight.	\$2,100.00
Equipment: Sky Tracker rental	\$275.00
Labor: 2 men 4.5 hrs each @ \$45.00 per hour	\$405.00
3) Brick materials 242 SF x \$5.84	\$1,412.90
Labor 4 men 10hrs each @ \$45 per hour	\$1,800.00

Modify existing rails at training tower (Item 2 of PR 7)

4) Materials 2 pcs ts 2x2x1/4 x 6' x \$91 each = \$182.	
2 pcs plate 1/2x4.5x 4' x \$110 = \$220.	
2 pcs. Plate 1/2x4"x1'4" x \$34.85 = \$69.70	
Total - \$471.70 plus 6% tax (\$28.30)	\$500.00
Shop Labor 6 hrs. @ \$50 per hour	\$300.00
Labor 2 men 6 hrs. each @ \$85 per hour	\$1,020.00

Total	\$11,660.70
10% Overhead	\$1,166.07
Grand Total	\$12,826.77

Contractor: Olympic Construction Representative: Dennis Kunitsa

Signature: _____ Date: 11/04/2016

12/15/1988

Ordinance

324-88