



**LEXINGTON**

# Lexington-Fayette Urban County Government

Lexington, Kentucky  
Horse Capital of the World

Division of Central Purchasing

Date of Issue: March 7, 2022

## INVITATION TO BID #19-2022 Inductive Vehicle Loop Protection

**Bid Opening Date:** March 21, 2022

**Bid Opening Time:** 2:00 PM

**Address:** All bids must be submitted on line at <https://lexingtonky.ionwave.net/>

**Type of Bid:** Price Contract

**Pre Bid Meeting:** N/A

**Pre Bid Time:** N/A

**Address:** N/A

Sealed bids will ONLY be received online at <https://lexingtonky.ionwave.net/> until **2:00 PM**, prevailing local time on **03/21/2022**. Bids must be submitted/uploaded by the above-mentioned date and time.

Bids are to include all shipping, handling and associated fees to the point of delivery (unless otherwise specified in the bid documents below) located at: Lexington, KY

<p style="text-align: center;"><b>Check One:</b></p> <p><input checked="" type="checkbox"/> Bid Specifications Met _____ Exceptions to Bid Specifications. <i>Exceptions shall be itemized and attached to bid proposal submitted.</i></p>	<p style="text-align: center;"><b>Proposed Delivery:</b></p> <p>Immediately _____ days after acceptance of bid. <small>As required per work order</small></p>
<p><b>Procurement Card Usage</b>—The Lexington-Fayette Urban County Government may be using Procurement Cards to purchase goods and services and also to make payments. Will you accept Procurement Cards? _____ Yes _____ <input checked="" type="checkbox"/> No</p>	

**To expedite award, the forms in this document should be completed and uploaded with your bid.**

Submitted by: Davis H. Elliot Construction Company, Inc.  
*Firm Name*

673 Blue Sky Parkway  
*Address*

Lexington, KY 40509  
*City, State & Zip*

*Bid must be signed:*   
**Signature of Authorized Company Representative – Title**

Reather Keith Simpson, Sr. Vice President  
*Representative's Name (Typed or printed)*

859-263-5148 x 2120                      859-263-5486  
*Area Code - Phone – Extension*                      *Fax #*

ksimpson@dhec.com  
*E-Mail Address*

*The Affidavit in this bid must be completed before your firm can be considered for award of this contract.*

**AFFIDAVIT**

Comes the Affiant, Reather Keith Simpson, and after being first duly sworn under penalty of perjury as follows:

1. His/her name is Reather Keith Simpson and he/she is the individual submitting the bid or is the authorized representative of Davis H. Elliot Construction Company, Inc. the entity submitting the bid (hereinafter referred to as "Bidder")
2. Bidder will pay all taxes and fees, which are owed to the Lexington-Fayette Urban County Government at the time the bid is submitted, prior to award of the contract and will maintain a "current" status in regard to those taxes and fees during the life of the contract.
3. Bidder will obtain a Lexington-Fayette Urban County Government business license, if applicable, prior to award of the contract.
4. Bidder has authorized the Division of Central Purchasing to verify the above-mentioned information with the Division of Revenue and to disclose to the Urban County Council that taxes and/or fees are delinquent or that a business license has not been obtained.
5. Bidder has not knowingly violated any provision of the campaign finance laws of the Commonwealth of Kentucky within the past five (5) years and the award of a contract to the Bidder will not violate any provision of the campaign finance laws of the Commonwealth.
6. Bidder has not knowingly violated any provision of Chapter 25 of the Lexington-Fayette Urban County Government Code of Ordinances, known as "Ethics Act."
7. Bidder acknowledges that "knowingly" for purposes of this Affidavit means, with respect to conduct or to circumstances described by a statute or ordinance defining an offense, that a person is aware or should have been aware that his conduct is of that nature or that the circumstance exists.

Further, Affiant sayeth naught.

  
Reather Keith Simpson, Sr. Vice President

**STATE OF** Kentucky

**COUNTY OF** Fayette

The foregoing instrument was subscribed, sworn to and acknowledged before me  
by Reather Keith Simpson, Sr. Vice President on this the 21st day  
of March, 2022.

My Commission expires: 11/12/2025



  
NOTARY PUBLIC, STATE AT LARGE Stephanie Lee Allen

*Please refer to Section II. Bid Conditions, Item "U" prior to completing this form.*

**I. GREEN PROCUREMENT**

**A. ENERGY**

The Lexington-Fayette Urban County Government is committed to protecting our environment and being fiscally responsible to our citizens.

The Lexington-Fayette Urban County Government mandates the use of Energy Star compliant products if they are available in the marketplace (go to [www.Energystar.gov](http://www.Energystar.gov)). If these products are available, but not submitted in your pricing, your bid will be rejected as non-compliant.

ENERGY STAR is a government program that offers businesses and consumers energy-efficient solutions, making it easy to save money while protecting the environment for future generations.

Key Benefits

- These products use 25 to 50% less energy
- Reduced energy costs without compromising quality or performance
- Reduced air pollution because fewer fossil fuels are burned
- Significant return on investment
- Extended product life and decreased maintenance

**B. GREEN SEAL CERTIFIED PRODUCTS**

The Lexington-Fayette Urban County Government is also committed to using other environmentally friendly products that do not negatively impact our environment. Green Seal is a non-profit organization devoted to environmental standard setting, product certification, and public education.

Go to [www.Greenseal.org](http://www.Greenseal.org) to find available certified products. These products will have a reduced impact on the environment and on human health. The products to be used must be pre-approved by the LFUCG prior to commencement of any work in any LFUCG facility. If a Green Seal product is not available, the LFUCG must provide a signed waiver to use an alternate product. Please provide information on the Green Seal products being used with your bid response.

**C. GREEN COMMUNITY**

**The Lexington-Fayette Urban County Government (LFUCG) serves as a principal, along with the University of Kentucky and Fayette County Public Schools, in the Bluegrass Partnership for a Green Community. The Purchasing Team component of the Partnership collaborates on economy of scale purchasing that promotes and enhances environmental initiatives. Specifically, when applicable, each principal is interested in obtaining best value products and/or services which promote environment initiatives via solicitations and awards from the other principals.**

**If your company is the successful bidder on this Invitation For Bid, do you agree to extend the same product/service pricing to the other principals of the Bluegrass Partnership for a Green Community (i.e. University of Kentucky and Fayette County Schools) if requested?**

Yes  No

**II. Bid Conditions**

- A. No bid may be withdrawn for a period of sixty (60) days after the date and time set for opening.
- B. No bid may be altered after the date and time set for opening. In the case of obvious errors, the Division of Central Purchasing may permit the withdrawal of a bid. The decision as to whether a bid may be withdrawn shall be that of the Division of Central Purchasing.
- C. Acceptance of this proposal shall be enactment of an Ordinance by the Urban County Council.
- D. The bidder agrees that the Urban County Government reserves the right to reject any and all bids for either fiscal



- or technical reasons, and to award each part of the bid separately, all parts to one vendor or all parts to multiple vendors.
- E. Minor exceptions may not eliminate the bidder. The decision as to whether any exception is minor shall be entirely that of the head of the requisitioning Department or Division and the Director of the Division of Central Purchasing. The Urban County Government may waive technicalities and informalities where such waiver would best serve the interests of the Urban County Government.
  - F. Manufacturer's catalogue numbers, trade names, etc., where shown herein are for descriptive purposes and are to guide the bidder in interpreting the standard of quality, design, and performance desired, and shall not be construed to exclude proposals based on furnishing other types of materials and/or services. However, any substitution or departure proposed by the bidder must be clearly noted and described; otherwise, it will be assumed that the bidder intends to supply items specifically mentioned in this Invitation for Bids.
  - G. The Urban County Government may require demonstrations of the materials proposed herein prior to acceptance of this proposal.
  - H. Bids must be submitted on this form and must be signed by the bidder or his authorized representative. Unsigned bids will not be considered.
  - I. Bids must be submitted prior to the date and time indicated for opening. Bids submitted after this time will not be considered.
  - J. All bids mailed must be submitted in the Ion Wave online portal at <https://lexingtonky.ionwave.net/>
  - K. Bidder is requested to show both unit prices and lot prices. In the event of error, the unit price shall prevail.
  - L. A certified check or Bid Bond in the amount of XX percent of the bid price must be attached hereto. This check must be made payable to the Lexington-Fayette Urban County Government, and will be returned when the material and/or services specified herein have been delivered in accordance with specifications. In the event of failure to perform within the time period set forth in this bid, it is agreed the certified check may be cashed and the funds retained by the Lexington-Fayette Urban County Government as liquidated damages. Checks of unsuccessful bidders will be returned when the bid has been awarded.
  - M. The delivery dates specified by bidder may be a factor in the determination of the successful bidder.
  - N. Tabulations of bids received may be mailed to bidders. Bidders requesting tabulations must enclose a stamped, self-addressed envelope with the bid.
  - O. The Lexington-Fayette Urban County Government is exempt from Kentucky Sales Tax and Federal Excise Tax on materials purchased from this bid invitation. Materials purchased by the bidder for construction projects are not tax exempt and are the sole responsibility of the bidder.
  - P. All material furnished hereunder must be in full compliance with OSHA regulations.
  - Q. If more than one bid is offered by one party, or by any person or persons representing a party, all such bids shall be rejected.
  - R. Signature on the face of this bid by the Bidder or his authorized representative shall be construed as acceptance of and compliance with all terms and conditions contained herein.
  - S. The Entity (regardless of whether construction contractor, non-construction contractor or supplier) agrees to provide equal opportunity in employment for all qualified persons, to prohibit discrimination in employment because of race, color, religion, sex (including pregnancy, sexual orientation or gender identity), national origin, disability, age, genetic information, political affiliation, or veteran status, and to promote equal employment through a positive, continuing program from itself and each of its sub-contracting agents. This program of equal employment opportunity shall apply to every aspect of its employment policies and practices.
  - T. The Kentucky Equal Employment Opportunity Act of 1978 (KRS 45.560-45.640) requires that any county, city, town, school district, water district, hospital district, or other political subdivision of the state shall include in directly

or indirectly publicly funded contracts for supplies, materials, services, or equipment hereinafter entered into the following provisions:

During the performance of this contract, the contractor agrees as follows:

- (1) The contractor will not discriminate against any employee or applicant for employment because of race, color, religion, sex, age or national origin;*
- (2) The contractor will state in all solicitations or advertisements for employees placed by or on behalf of the contractors that all qualified applicants will receive consideration for employment without regard to race, color, religion, sex, age or national origin;*
- (3) The contractor will post notices in conspicuous places, available to employees and applicants for employment, setting forth the provisions of the non-discrimination clauses required by this section; and*
- (4) The contractor will send a notice to each labor union or representative of workers with which he has a collective bargaining agreement or other contract or understanding advising the labor union or workers' representative of the contractor's commitments under the nondiscrimination clauses.*

The Act further provides:

KRS 45.610. Hiring minorities - Information required

- (1) For the length of the contract, each contractor shall hire minorities from other sources within the drawing area, should the union with which he has collective bargaining agreements be unwilling to supply sufficient minorities to satisfy the agreed upon goals and timetable.*
- (2) Each contractor shall, for the length of the contract, furnish such information as required by KRS 45.560 to KRS 45.640 and by such rules, regulations and orders issued pursuant thereto and will permit access to all books and records pertaining to his employment practices and work sites by the contracting agency and the department for purposes of investigation to ascertain compliance with KRS 45.560 to 45.640 and such rules, regulations and orders issued pursuant thereto.*

KRS 45.620. Action against contractor - Hiring of minority contractor or subcontractor

- (1) If any contractor is found by the department to have engaged in an unlawful practice under this chapter during the course of performing under a contract or subcontract covered under KRS 45.560 to 45.640, the department shall so certify to the contracting agency and such certification shall be binding upon the contracting agency unless it is reversed in the course of judicial review.*
- (2) If the contractor is found to have committed an unlawful practice under KRS 45.560 to 45.640, the contracting agency may cancel or terminate the contract, conditioned upon a program for future compliance approved by the contracting agency and the department. The contracting agency may declare such a contractor ineligible to bid on further contracts with that agency until such time as the contractor complies in full with the requirements of KRS 45.560 to 45.640.*
- (3) The equal employment provisions of KRS 45.560 to 45.640 may be met in part by a contractor by subcontracting to a minority contractor or subcontractor. For the provisions of KRS 45.560 to 45.640, a minority contractor or subcontractor shall mean a business that is owned and controlled by one or more persons disadvantaged by racial or ethnic circumstances.*

KRS 45.630 Termination of existing employee not required, when

*Any provision of KRS 45.560 to 45.640 notwithstanding, no contractor shall be required to terminate an existing employee upon proof that that employee was employed prior to the date of the contract.*

KRS 45.640 Minimum skills

*Nothing in KRS 45.560 to 45.640 shall require a contractor to hire anyone who fails to demonstrate the minimum skills required to perform a particular job.*

It is recommended that all of the provisions above quoted to be included as special conditions in each contract.

In the case of a contract exceeding \$250,000, the contractor is required to furnish evidence that his work-force in Kentucky is representative of the available work-force in the area from which he draws employees, or to supply an Affirmative Action plan which will achieve such representation during the life of the contract.

- U. Any party, firm or individual submitting a proposal pursuant to this invitation must be in compliance with the requirements of the Lexington-Fayette Urban County Government regarding taxes and fees before they can be considered for award of this invitation and must maintain a "current" status with regard to those taxes and fees throughout the term of the contract. The contractor must be in compliance with Chapter 13 from the Code of Ordinances of the Lexington-Fayette Urban County Government. The contractor must be in compliance with Ordinance 35-2000 pursuant to contractor registration with the Division of Building Inspection. If applicable, said business must have a Fayette County business license.

Pursuant to KRS 45A.343 and KRS 45A.345, the contractor shall

- (1) *Reveal any final determination of a violation by the contractor within the previous five year period pursuant to KRS Chapters 136 (corporation and utility taxes), 139 (sales and use taxes), 141 (income taxes), 337 (wages and hours), 338 (occupational safety and health of employees), 341 (unemployment and compensation) and 342 (labor and human rights) that apply to the contractor; and*
- (2) *Be in continuous compliance with the above-mentioned KRS provisions that apply to the contractor for the duration of the contract.*

A contractor's failure to reveal the above or to comply with such provisions for the duration of the contract shall be grounds for cancellation of the contract and disqualification of the contractor from eligibility for future contracts for a period of two (2) years.

- V. Vendors who respond to this invitation have the right to file a notice of contention associated with the bid process or to file a notice of appeal of the recommendation made by the Director of Central Purchasing resulting from this invitation.

Notice of contention with the bid process must be filed within 3 business days of the bid/proposal opening by (1) sending a written notice, including sufficient documentation to support contention, to the Director of the Division of Central Purchasing or (2) submitting a written request for a meeting with the Director of Central Purchasing to explain his/her contention with the bid process. After consulting with the Commissioner of Finance the Chief Administrative Officer and reviewing the documentation and/or hearing the vendor, the Director of Central Purchasing shall promptly respond in writing findings as to the compliance with bid processes. If, based on this review, a bid process irregularity is deemed to have occurred the Director of Central Purchasing will consult with the Commissioner of Finance, the Chief Administrative Officer and the Department of Law as to the appropriate remedy.

Notice of appeal of a bid recommendation must be filed within 3 business days of the bid recommendation by (1) sending a written notice, including sufficient documentation to support appeal, to the Director, Division of Central Purchasing or (2) submitting a written request for a meeting with the Director of Central Purchasing to explain his appeal. After reviewing the documentation and/or hearing the vendor and consulting with the Commissioner of Finance and the Chief Administrative Officer, the Director of Central Purchasing shall in writing, affirm or withdraw the recommendation.

### III. Procurement Contract Bid Conditions

- A. The terms of this agreement shall be for 1 year(s) from the date of acceptance of this contract by the Lexington-Fayette Urban County Government. This agreement may be automatically extended for an additional 1 year(s) renewal. This contract may be canceled by either party thirty (30) days after delivery by canceling party of written notice of intent to cancel to the other contracting party.
  
- B. Price Changes **(Space Checked Applies)**
  - (XXX)1. Prices quoted in response to the Invitation shall be firm prices for the first 90 days of the Procurement Contract. After 90 days, prices may be subject to revision and such changes shall be based on general industry changes. Revision may be either increases or decreases and may be requested by either party. There will be no more than one (1) price adjustment per year. Requests for price changes shall be received in writing at least twenty (20) days prior to the effective date and are subject to written acceptance before becoming effective. Proof of the validity of a request for revision shall be responsibility of the requesting party. The Lexington-Fayette Urban County Government shall receive the benefit of any decline that the seller shall offer his other accounts.
  
  - 2. No provision for price change is made herein. Prices are to be firm for the term of this contract.
  
  - 3. See bid specifications.
  
- C. If any contract item is not available from the vendor, the Lexington-Fayette Urban County Government, at its option, may permit the item to be back-ordered or may procure the item on the open market.
  
- D. All invoices must bear reference to the Lexington-Fayette Urban County Government Purchasing document numbers which are being billed.
  
- E. This contract may be canceled by the Lexington-Fayette Urban County Government if it is determined that the Bidder has failed to perform under the terms of this agreement, such cancellation to be effective upon receipt of written notice of cancellation by the Bidder.
  
- F. No substitutions for articles specified herein may be made without prior approval of the Division of Central Purchasing.

## EQUAL OPPORTUNITY AGREEMENT

### Standard Title VI Assurance

The Lexington Fayette-Urban County Government, (hereinafter referred to as the "Recipient") hereby agrees that as a condition to receiving any Federal financial assistance from the U.S. Department of Transportation, it will comply with Title VI of the Civil Rights Act of 1964, 78Stat.252, 42 U.S.C. 2000d-4 (hereinafter referred to as the "Act"), and all requirements imposed by or pursuant to Title 49, Code of Federal Regulations, U.S. Department of Transportation, Subtitle A, Office of the Secretary, (49 CFR, Part 21) Nondiscrimination in Federally Assisted Program of the Department of Transportation – Effectuation of Title VI of the Civil Rights Act of 1964 (hereinafter referred to as the "Regulations") and other pertinent directives, no person in the United States shall, on the grounds of race, color, national origin, sex, age (over 40), religion, sexual orientation, gender identity, veteran status, or disability be excluded from participation in, be denied the benefits of, or be otherwise subjected to discrimination under any program or activity for which the Recipient receives Federal financial assistance from the U.S. Department of Transportation, including the Federal Highway Administration, and hereby gives assurance that will promptly take any necessary measures to effectuate this agreement. This assurance is required by subsection 21.7(a) (1) of the Regulations.

### The Law

- Title VII of the Civil Rights Act of 1964 (amended 1972) states that it is unlawful for an employer to discriminate in employment because of race, color, religion, sex, age (40-70 years) or national origin.
- Executive Order No. 11246 on Nondiscrimination under Federal contract prohibits employment discrimination by contractor and sub-contractor doing business with the Federal Government or recipients of Federal funds. This order was later amended by Executive Order No. 11375 to prohibit discrimination on the basis of sex.
- Section 503 of the Rehabilitation Act of 1973 states: *The Contractor will not discriminate against any employee or applicant for employment because of physical or mental disability.*
- Section 2012 of the Vietnam Era Veterans Readjustment Act of 1973 requires Affirmative Action on behalf of disabled veterans and veterans of the Vietnam Era by contractors having Federal contracts.
- Section 206(A) of Executive Order 12086, Consolidation of Contract Compliance Functions for Equal Employment Opportunity, states: *The Secretary of Labor may investigate the employment practices of any Government contractor or sub-contractor to determine whether or not the contractual provisions specified in Section 202 of this order have been violated.*

The Lexington-Fayette Urban County Government practices Equal Opportunity in recruiting, hiring and promoting. It is the Government's intent to affirmatively provide employment opportunities for those individuals who have previously not been allowed to enter into the mainstream of society. Because of its importance to the local Government, this policy carries the full endorsement of the Mayor, Commissioners, Directors and all supervisory personnel. In following this commitment to Equal Employment Opportunity and because the Government is the benefactor of the Federal funds, it is both against the Urban County Government policy and illegal for the Government to let contracts to companies which knowingly or unknowingly practice discrimination in their employment practices. Violation of the above mentioned ordinances may cause a contract to be canceled and the contractors may be declared ineligible for future consideration.

Please sign this statement in the appropriate space acknowledging that you have read and understand the provisions contained herein. Return this document as part of your application packet.

### Bidders

*I/We agree to comply with the Civil Rights Laws listed above that govern employment rights of minorities, women, veteran status, disability and age.*

  
Signature Reather Keith Simpson, Sr. Vice President

Davis H. Elliot Construction Company, Inc.  
Name of Business



## GENERAL PROVISIONS OF BID CONTRACT

By signing the below, bidder acknowledges that it understands and agrees with the following provisions related to its bid response and the provision of any goods or services to LFUCG upon selection by LFUCG pursuant to the bid request:

1. Bidder shall comply with all Federal, State & Local regulations concerning this type of service or good. All applicable state laws, ordinances and resolutions (including but not limited to Section 2-33 (Discrimination due to sexual orientation or gender identity) and Chapter 13 (Licenses and Regulations) of the Lexington-Fayette Urban County Government Code of Ordinances, and Resolution No. 484-17 (Minority, Women, and Veteran-Owned Businesses)) and the regulations of all authorities having jurisdiction over the project shall apply to the contract, and shall be deemed to be incorporated herein by reference.
2. Failure to submit ALL forms and information required by LFUCG may be grounds for disqualification.
3. Addenda: All addenda and IonWave Q&A, if any, must be considered by the bidder in making its response, and such addenda shall be made a part of the requirements of the bid contract. Before submitting a bid response, it is incumbent upon bidder to be informed as to whether any addenda have been issued, and the failure of the bidder to cover any such addenda may result in disqualification of that response.
4. Bid Reservations: LFUCG reserves the right to reject any or all bid responses, to award in whole or part, and to waive minor immaterial defects in proposals. LFUCG may consider any alternative proposal that meets its basic needs.
5. Liability: LFUCG is not responsible for any cost incurred by bidder in the preparation of its response.
6. Changes/Alterations: Bidder may change or withdraw a proposal at any time prior to the opening; however, no oral modifications will be allowed. Only letters, or other formal written requests for modifications or corrections of a previously submitted proposal which is addressed in the same manner as the bid response, and received by LFUCG prior to the scheduled closing time for receipt of bids, will be accepted. The bid response when opened, will then be corrected in accordance with such written request(s), provided that the written request is contained in a sealed envelope which is plainly marked "modifications of bid response".
7. Clarification of Submittal: LFUCG reserves the right to obtain clarification of any point in a bid or to obtain additional information from any bidder.
8. Bribery Clause: By his/her signature on its response, bidder certifies that no employee of his/hers, any affiliate or subcontractor, has bribed or attempted to bribe an officer or employee of the LFUCG.
9. Additional Information: While not necessary, the bidder may include any product brochures, software documentation, sample reports, or other documentation that may assist LFUCG in better understanding and evaluating the bid response. Additional documentation shall not serve as a substitute for other documentation which is required by the LFUCG to be submitted with the bid response.
10. Ambiguity, Conflict or other Errors: If a bidder discovers any ambiguity, conflict, discrepancy, omission or other error in the bid request of LFUCG, it shall immediately notify LFUCG of such error in writing and request modification or clarification of the document if allowable by the LFUCG.
11. Agreement to Bid Terms: In submitting its bid response, the bidder agrees that it has carefully examined the specifications and all provisions relating to LFUCG's bid request, including but not limited to the bid contract. By submission of its bid response, bidder states that it understands the meaning, intent and requirements of LFUCG's bid request and agrees to the same. The successful bidder shall warrant that it is familiar with and understands all provisions herein and shall warrant that it can comply with them. No additional compensation to bidder shall be authorized for services, expenses, or goods reasonably covered under these provisions that the bidder omits from its bid response.
12. Cancellation: LFUCG may unilaterally terminate the bid contract with the selected bidder(s) at any time, with or without cause, by providing at least thirty (30) days advance written notice unless a different advance written notice

period is negotiated prior to contract approval. Payment for services or goods received prior to termination shall be made by the LFUCG provided these goods or services were provided in a manner acceptable to the LFUCG. Payment for those goods and services shall not be unreasonably withheld.

13. Assignment of Contract: The selected bidder(s) shall not assign or subcontract any portion of the bid contract with LFUCG without the express written consent of LFUCG. Any purported assignment or subcontract in violation hereof shall be void. It is expressly acknowledged that LFUCG shall never be required or obligated to consent to any request for assignment or subcontract; and further that such refusal to consent can be for any or no reason, fully within the sole discretion of LFUCG.
14. No Waiver: No failure or delay by LFUCG in exercising any right, remedy, power or privilege hereunder, nor any single or partial exercise thereof, nor the exercise of any other right, remedy, power or privilege shall operate as a waiver hereof or thereof. No failure or delay by LFUCG in exercising any right, remedy, power or privilege under or in respect of this bid proposal or bid contract shall affect the rights, remedies, powers or privileges of LFUCG hereunder or shall operate as a waiver thereof.
15. Authority to do Business: Each bidder must be authorized to do business under the laws of the Commonwealth of Kentucky and must be in good standing and have full legal capacity to provide the goods or services specified in the bid proposal. Each bidder must have all necessary right and lawful authority to submit the bid response and enter into the bid contract for the full term hereof including any necessary corporate or other action authorizing the bidder to submit the bid response and enter into this bid contract. If requested, the bidder will provide LFUCG with a copy of a corporate resolution authorizing this action and/or a letter from an attorney confirming that the proposer is authorized to do business in the Commonwealth of Kentucky. All bid responses must be signed by a duly authorized officer, agent or employee of the bidder.
16. Governing Law: This bid request and bid contract shall be governed by and construed in accordance with the laws of the Commonwealth of Kentucky. In the event of any proceedings regarding this matter, the bidder agrees that the venue shall be the Fayette County Circuit Court or the U.S. District Court for the Eastern District of Kentucky, Lexington Division and that the bidder expressly consents to personal jurisdiction and venue in such Court for the limited and sole purpose of proceedings relating to these matters or any rights or obligations arising thereunder.
17. Ability to Meet Obligations: Bidder affirmatively states that there are no actions, suits or proceedings of any kind pending against bidder or, to the knowledge of the bidder, threatened against the bidder before or by any court, governmental body or agency or other tribunal or authority which would, if adversely determined, have a materially adverse effect on the authority or ability of bidder to perform its obligations under this bid response or bid contract, or which question the legality, validity or enforceability hereof or thereof.
18. Price Discrepancy: When applicable, in case of price discrepancy, unit bid price written in words will prevail followed by unit price written in numbers then total amount bid per line item.
19. Bidder understands and agrees that its employees, agents, or subcontractors are not employees of LFUCG for any purpose whatsoever. Bidder is an independent contractor at all times related to the bid response or bid contract.
20. Contractor [or Vendor or Vendor's Employees] will not appropriate or make use of the Lexington-Fayette Urban County Government (LFUCG) name or any of its trade or service marks or property (including but not limited to any logo or seal), in any promotion, endorsement, advertisement, testimonial or similar use without the prior written consent of the government. If such consent is granted LFUCG reserves the unilateral right, in its sole discretion, to immediately terminate and revoke such use for any reason whatsoever. Contractor agrees that it shall cease and desist from any unauthorized use immediately upon being notified by LFUCG.
21. If any term or provision of this bid contract shall be found to be illegal or unenforceable, the remainder of the contract shall remain in full force and such term or provision shall be deemed stricken.

  
Signature Reather Keith Simpson,  
Sr. Vice President

03/21/2022  
Date

**WORKFORCE ANALYSIS FORM**

Name of Organization: Davis H. Elliot Construction Company, Inc.

Categories	Total	White (Not Hispanic or Latino)		Hispanic or Latino		Black or African-American (Not Hispanic or Latino)		Native Hawaiian and Other Pacific Islander (Not Hispanic or Latino)		Asian (Not Hispanic or Latino)		American Indian or Alaskan Native (not Hispanic or Latino)		Two or more races (Not Hispanic or Latino)		Total	
		M	F	M	F	M	F	M	F	M	F	M	F	M	F	M	F
<b>Administrators</b>																	
<b>Professionals</b>	79	64	10	2		1				1				1		69	10
<b>Superintendents</b>																	
<b>Supervisors</b>																	
<b>Foremen</b>																	
<b>Technicians</b>																	
<b>Protective Service</b>																	
<b>Para-Professionals</b>																	
<b>Office/Clerical</b>	86	32	49	1	1	1	2									34	52
<b>Skilled Craft</b>	1911	1765	7	25		30		1		2		57		22	2	1902	9
<b>Service/Maintenance</b>																	
<b>Total:</b>	2076	1861	66	28	1	32	2	1		3		57		23	2	2005	71

Prepared by:   
 (Name and Title) Reather Keith Simpson, Sr. Vice President

Date: 03 / 21 / 2022

Revised 2015-Dec-15



**DIRECTOR, DIVISION OF CENTRAL PURCHASING  
LEXINGTON-FAYETTE URBAN COUNTY GOVERNMENT  
200 EAST MAIN STREET  
LEXINGTON, KENTUCKY 40507**

**NOTICE OF REQUIREMENT FOR AFFIRMATIVE ACTION TO ENSURE  
EQUAL EMPLOYMENT OPPORTUNITIES AND DBE CONTRACT PARTICIPATION**

The Lexington-Fayette Urban County Government has set a goal that not less than ten percent (10%) of the total value of this contract be subcontracted to MBE/WBE's, and set a goal that not less than three percent (3%) of the total value of this contract be subcontracted to Veteran-Owned Small Businesses. The goal for the utilization of Certified MBE/WBE's and Veteran-Owned Small Businesses as subcontractors are recommended goals. Contractors who fail to meet such goals will be expected to provide written explanations to the Director of the Division of Central Purchasing of efforts they have made to accomplish the recommended goals and the extent to which they are successful in accomplishing the recommended goals will be a consideration in the procurement process.

For assistance in locating MBE/WBE Subcontractors contact Sherita Miller at 859/258-3320 or by writing the address listed below:

Sherita Miller, Division of Central Purchasing  
Lexington-Fayette Urban County Government  
200 East Main Street – Room 338  
Lexington, Kentucky 40507  
[smiller@lexingtonky.gov](mailto:smiller@lexingtonky.gov)



## **Lexington-Fayette Urban County Government MWDBE PARTICIPATION GOALS**

### **A. GENERAL**

- 1) The LFUCG request all potential contractors to make a concerted effort to include Minority-Owned (MBE), Woman-Owned (WBE), Disadvantaged (DBE) Business Enterprises and Veteran-Owned Small Businesses (VOSB) as subcontractors or suppliers in their bids.
- 2) Toward that end, the LFUCG has established 10% of total procurement costs as a Goal for participation of Minority-Owned, Woman-Owned and Disadvantaged Businesses on this contract.
- 3) **It is therefore a request of each Bidder to include in its bid, the same goal (10%) for MWDBE participation and other requirements as outlined in this section.**
- 4) The LFUCG has also established a 3% of total procurement costs as a Goal for participation for of Veteran-Owned Businesses.
- 5) **It is therefore a request of each Bidder to include in its bid, the same goal (3%) for Veteran-Owned participation and other requirements as outlined in this section.**

### **B. PROCEDURES**

- 1) The successful bidder will be required to report to the LFUCG, the dollar amounts of all payments submitted to Minority-Owned, Woman-Owned or Veteran-Owned subcontractors and suppliers for work done or materials purchased for this contract. (See Subcontractor Monthly Payment Report)
- 2) Replacement of a Minority-Owned, Woman-Owned or Veteran-Owned subcontractor or supplier listed in the original submittal must be requested in writing and must be accompanied by documentation of Good Faith Efforts to replace the subcontractor / supplier with another MWDBE Firm; this is subject to approval by the LFUCG. (See LFUCG MWDBE Substitution Form)
- 3) For assistance in identifying qualified, certified businesses to solicit for potential contracting opportunities, bidders may contact:
  - a) The Lexington-Fayette Urban County Government, Division of Central Purchasing (859-258-3320)
- 4) The LFUCG will make every effort to notify interested MWDBE and Veteran-Owned subcontractors and suppliers of each Bid Package, including information on the scope of work, the pre-bid meeting time and location, the bid date, and all other pertinent information regarding the project.

### **C. DEFINITIONS**

- 1) A Minority-Owned Business Enterprise (MBE) is defined as a business which is certified as being at least 51% owned, managed and controlled by persons of African American, Hispanic, Asian, Pacific Islander, American Indian or Alaskan Native Heritage.
- 2) A Woman-Owned Business Enterprise (WBE) is defined as a business which is certified as being at least 51% owned, managed and controlled by one or more women.
- 3) A Disadvantaged Business (DBE) is defined as a business which is certified as being at least 51% owned, managed and controlled by a person(s) that are economically and socially disadvantaged.

- 4) A Veteran-Owned Small Business (VOSB) is defined as a business which is certified as being at least 51% owned, managed and controlled by a veteran and/or a service disabled veteran.
- 5) Good Faith Efforts are efforts that, given all relevant circumstances, a bidder or proposer actively and aggressively seeking to meet the goals, can reasonably be expected to make. In evaluating good faith efforts made toward achieving the goals, whether the bidder or proposer has performed the efforts outlined in the Obligations of Bidder for Good Faith Efforts outlined in this document will be considered, along with any other relevant factors.

#### D. OBLIGATION OF BIDDER FOR GOOD FAITH EFFORTS

- 1) **The bidder shall make a Good Faith Effort to achieve the Participation Goal for MWDBE and Veteran-Owned subcontractors/suppliers. The failure to meet the goal shall not necessarily be cause for disqualification of the bidder; however, bidders not meeting the goal are required to furnish with their bids written documentation of their Good Faith Efforts to do so.**
- 2) Award of Contract shall be conditioned upon satisfaction of the requirements set forth herein.
- 3) The Form of Proposal includes a section entitled “MWDBE Participation Form”. The applicable information must be completed and submitted as outlined below.
- 4) **Failure to submit this information as requested may be cause for rejection of bid or delay in contract award.**

#### E. DOCUMENTATION REQUIRED FOR GOOD FAITH EFFORTS

- 1) Bidders reaching the Goal are required to submit only the MWDBE Participation Form.” The form must be fully completed including names and telephone number of participating MWDBE firm(s); type of work to be performed; estimated value of the contract and value expressed as a percentage of the total Lump Sum Bid Price. The form must be signed and dated, and is to be submitted with the bid.
- 2) Bidders not reaching the Goal must submit the “MWDBE Participation Form”, the “Quote Summary Form” and a written statement documenting their Good Faith Effort to do so. If bid includes no MWDBE and/or Veteran participation, bidder shall enter “None” on the subcontractor / supplier form). In addition, the bidder must submit written proof of their Good Faith Efforts to meet the Participation Goal:
  - a. Advertised opportunities to participate in the contract in at least two (2) publications of general circulation media; trade and professional association publications; small and minority business or trade publications; and publications or trades targeting minority, women and disadvantaged businesses not less than fifteen (15) days prior to the deadline for submission of bids to allow MWDBE firms and Veteran-Owned businesses to participate.
  - b. Included documentation of advertising in the above publications with the bidders good faith efforts package
  - c. Attended LFUCG Central Purchasing Economic Inclusion Outreach event
  - d. Attended pre-bid meetings that were scheduled by LFUCG to inform MWDBEs and/or Veteran-Owned businesses of subcontracting opportunities

- e. Sponsored Economic Inclusion event to provide networking opportunities for prime contractors and MWDBE firms and Veteran-Owned businesses.
- f. Requested a list of MWDBE and/or Veteran subcontractors or suppliers from LFUCG and showed evidence of contacting the companies on the list(s).
- g. Contacted organizations that work with MWDBE companies for assistance in finding certified MWDBE firms and Veteran-Owned businesses to work on this project. Those contacted and their responses should be a part of the bidder's good faith efforts documentation.
- h. Sent written notices, by certified mail, email or facsimile, to qualified, certified MWDBEs and/or Veteran-Owned businesses soliciting their participation in the contract not less than seven (7) days prior to the deadline for submission of bids to allow them to participate effectively.
- i. Followed up initial solicitations by contacting MWDBEs and Veteran-Owned Businesses to determine their level of interest.
- j. Provided the interested MWDBE firm and/or Veteran-Owned business with adequate and timely information about the plans, specifications, and requirements of the contract.
- k. Selected portions of the work to be performed by MWDBE firms and/or Veteran-Owned businesses in order to increase the likelihood of meeting the contract goals. This includes, where appropriate, breaking out contract work items into economically feasible units to facilitate MWDBE and Veteran participation, even when the prime contractor may otherwise perform these work items with its own workforce
- l. Negotiated in good faith with interested MWDBE firms and Veteran-Owned businesses not rejecting them as unqualified without sound reasons based on a thorough investigation of their capabilities. Any rejection should be so noted in writing with a description as to why an agreement could not be reached.
- m. Included documentation of quotations received from interested MWDBE firms and Veteran-Owned businesses which were not used due to uncompetitive pricing or were rejected as unacceptable and/or copies of responses from firms indicating that they would not be submitting a bid.
- n. Bidder has to submit sound reasons why the quotations were considered unacceptable. The fact that the bidder has the ability and/or desire to perform the contract work with its own forces will not be considered a sound reason for rejecting a MWDBE and/or Veteran-Owned business's quote. Nothing in this provision shall be construed to require the bidder to accept unreasonable quotes in order to satisfy MWDBE and Veteran goals.
- o. Made an effort to offer assistance to or refer interested MWDBE firms and Veteran-Owned businesses to obtain the necessary equipment, supplies, materials, insurance and/or bonding to satisfy the work requirements of the bid proposal
- p. Made efforts to expand the search for MWBE firms and Veteran-Owned businesses beyond the usual geographic boundaries.

q. Other--any other evidence that the bidder submits which may show that the bidder has made reasonable good faith efforts to include MWDBE and Veteran participation.

**Note: Failure to submit any of the documentation requested in this section may be cause for rejection of bid. Bidders may include any other documentation deemed relevant to this requirement which is subject to review by the MBE Liaison. Documentation of Good Faith Efforts must be submitted with the Bid, if the participation Goal is not met.**





## MINORITY BUSINESS ENTERPRISE PROGRAM

Sherita Miller, MPA  
Minority Business Enterprise Liaison  
Division of Central Purchasing  
Lexington-Fayette Urban County Government  
200 East Main Street  
Lexington, KY 40507  
[smiller@lexingtonky.gov](mailto:smiller@lexingtonky.gov)  
859-258-3323

**OUR MISSION:** The mission of the Minority Business Enterprise Program is to facilitate the full participation of minority and women owned businesses in the procurement process and to promote economic inclusion as a business imperative essential to the long term economic viability of Lexington-Fayette Urban County Government.

To that end the city council adopted and implemented Resolution 484-2017 – A Certified Minority, Women and Disadvantaged Business Enterprise ten percent (10%) minimum goal and a three (3%) minimum goal for Certified Veteran-Owned Small Businesses and Certified Service Disabled Veteran – Owned Businesses for government contracts.

The resolution states the following definitions shall be used for the purposes of reaching these goals (a full copy is available in Central Purchasing):

***Certified Disadvantaged Business Enterprise (DBE)*** – a business in which at least fifty-one percent (51%) is owned, managed and controlled by a person(s) who is socially and economically disadvantaged as define by 49 CFR subpart 26.

***Certified Minority Business Enterprise (MBE)*** – a business in which at least fifty-one percent (51%) is owned, managed and controlled by an ethnic minority (i.e. African American, Asian American/Pacific Islander, Hispanic Islander, Native American/Native Alaskan Indian) as defined in federal law or regulation as it may be amended from time-to-time.

***Certified Women Business Enterprise (WBE)*** – a business in which at least fifty-one percent (51%) is owned, managed and controlled by a woman.

***Certified Veteran-Owned Small Business (VOSB)*** – a business in which at least fifty-one percent (51%) is owned, managed and controlled by a veteran who served on active duty with the U.S. Army, Air Force, Navy, Marines or Coast Guard.

***Certified Service Disabled Veteran Owned Small Business (SDVOSB)*** – a business in which at least fifty-one percent (51%) is owned, managed and controlled by a disabled veteran who served on active duty with the U.S. Army, Air Force, Navy, Marines or Coast Guard.

The term “Certified” shall mean the business is appropriately certified, licensed, verified, or validated by an organization or entity recognized by the Division of Purchasing as having the appropriate credentials to make a determination as to the status of the business.

To comply with Resolution 484-2017, prime contractors and minority, women and veteran owned businesses must enroll in the new Diverse Business Management Compliance system, <https://lexingtonky.diversitycompliance.com/>

We have compiled the list below to help you locate certified MBE, WBE and DBE certified businesses. Below is a listing of contacts for LFUCG Certified MWDBEs and Veteran-Owned Small Businesses in (<https://lexingtonky.ionwave.net>)

<b>Business</b>	<b>Contact</b>	<b>Email Address</b>	<b>Phone</b>
<b>LFUCG</b>	Sherita Miller	<a href="mailto:smiller@lexingtonky.gov">smiller@lexingtonky.gov</a>	859-258-3323
<b>Commerce Lexington – Minority Business Development</b>	Tyrone Tyra	<a href="mailto:tyra@commercelexington.com">tyra@commercelexington.com</a>	859-226-1625
<b>Tri-State Minority Supplier Diversity Council</b>	Susan Marston	<a href="mailto:smarston@tsmsdc.com">smarston@tsmsdc.com</a>	502-365-9762
<b>Small Business Development Council</b>	Shawn Rogers UK SBDC	<a href="mailto:shawn.rogers@uky.edu">shawn.rogers@uky.edu</a>	859-257-7666
<b>Community Ventures Corporation</b>	Phyllis Alcorn	<a href="mailto:palcorn@cvky.org">palcorn@cvky.org</a>	859-231-0054
<b>KY Transportation Cabinet (KYTC)</b>	Melvin Byne	<a href="mailto:Melvin.bynes2@ky.gov">Melvin.bynes2@ky.gov</a>	502-564-3601
<b>KYTC Pre-Qualification</b>	Shella Eagle	<a href="mailto:Shella.Eagle@ky.gov">Shella.Eagle@ky.gov</a>	502-782-4815
<b>Ohio River Valley Women’s Business Council (WBENC)</b>	Sheila Mixon	<a href="mailto:smixon@orwbc.org">smixon@orwbc.org</a>	513-487-6537
<b>Kentucky MWBE Certification Program</b>	Yvette Smith, Kentucky Finance Cabinet	<a href="mailto:Yvette.Smith@ky.gov">Yvette.Smith@ky.gov</a>	502-564-8099
<b>National Women Business Owner’s Council (NWBOC)</b>	Janet Harris-Lange	<a href="mailto:janet@nwbo.org">janet@nwbo.org</a>	800-675-5066
<b>Small Business Administration</b>	Robert Coffey	<a href="mailto:robertcoffey@sba.gov">robertcoffey@sba.gov</a>	502-582-5971
<b>LaVoz de Kentucky</b>	Andres Cruz	<a href="mailto:lavozdeky@yahoo.com">lavozdeky@yahoo.com</a>	859-621-2106
<b>The Key News Journal</b>	Patrice Muhammad	<a href="mailto:production@keynewsjournal.com">production@keynewsjournal.com</a>	859-685-8488



**LFUCG MWDBE PARTICIPATION FORM**

**Bid/RFP/Quote Reference #** #19-2022 Inductive Vehicle Loop Protection

The MWDBE and/or veteran subcontractors listed have agreed to participate on this Bid/RFP/Quote. If any substitution is made or the total value of the work is changed prior to or after the job is in progress, it is understood that those substitutions must be submitted to Central Purchasing for approval immediately. **Failure to submit a completed form may cause rejection of the bid.**

MWDBE Company, Name, Address, Phone, Email	MBE WBE or DBE	Work to be Performed	Total Dollar Value of the Work	% Value of Total Contract
1. Please see page 20.				
2.				
3.				
4.				

The undersigned company representative submits the above list of MWDBE firms to be used in accomplishing the work contained in this Bid/RFP/Quote. Any misrepresentation may result in the termination of the contract and/or be subject to applicable Federal and State laws concerning false statements and false claims.

Davis H. Elliot Construction Company, Inc.

Company

03/21/2022

Date

Company Representative

Reather Keith Simpson,  
Sr. Vice President

Title



**LFUCG MWDBE PARTICIPATION FORM**

**Bid/RFP/Quote Reference # #19-2022 Inductive Vehicle Loop Protection**

The MWDBE and/or veteran subcontractors listed have agreed to participate on this Bid/RFP/Quote. If any substitution is made or the total value of the work is changed prior to or after the job is in progress, it is understood that those substitutions must be submitted to Central Purchasing for approval immediately. **Failure to submit a completed form may cause rejection of the bid.**

MWDBE Company, Name, Address, Phone, Email	MBE WBE or DBE	Work to be Performed	Total Dollar Value of the Work	% Value of Total Contract
1.  Please see attached.				
2.				
3.				
4.				

The undersigned company representative submits the above list of MWDBE firms to be used in accomplishing the work contained in this Bid/RFP/Quote. Any misrepresentation may result in the termination of the contract and/or be subject to applicable Federal and State laws concerning false statements and false claims.

Davis H. Elliot Construction Company, Inc.  
Company

03/21/2022  
Date

  
Company Representative

Reather Keith Simpson, Sr. Vice President  
Title





# LEXINGTON

## LFUCG MWDBE SUBSTITUTION FORM

**Bid/RFP/Quote Reference #** #19-2022 Inductive Vehicle Loop Protection

The substituted MWDBE and/or veteran subcontractors listed below have agreed to participate on this Bid/RFP/Quote. These substitutions were made prior to or after the job was in progress. These substitutions were made for reasons stated below and are now being submitted to Central Purchasing for approval. By the authorized signature of a representative of our company, we understand that this information will be entered into our file for this project. **Failure to submit this form may cause rejection of the bid.**

SUBSTITUTED MWDBE Company Name, Address, Phone, Email	MWDBE Formally Contracted/ Name, Address, Phone, Email	Work to Be Performed	Reason for the Substitution	Total Dollar Value of the Work	% Value of Total Contract
1.  Form acknowledged. Not applicable at this time.					
2.					
3.					
4.					

The undersigned acknowledges that any misrepresentation may result in termination of the contract and/or be subject to applicable Federal and State laws concerning false statements and false claims.

Davis H. Elliot Construction Company, Inc.  
**Company**

03/21/2022  
**Date**

  
**Company Representative**

Reather Keith Simpson, Sr. Vice President  
**Title**



# LEXINGTON

## MWDBE QUOTE SUMMARY FORM

Bid/RFP/Quote Reference # #19-2022 Inductive Vehicle Loop Protection

The undersigned acknowledges that the minority and/or veteran subcontractors listed on this form did submit a quote to participate on this project. Failure to submit this form may cause rejection of the bid.

<b>Company Name</b> Davis H. Elliot Construction Company, Inc.	<b>Contact Person</b> Reather Keith Simpson, Sr. Vice President
<b>Address/Phone/Email</b> 673 Blue Sky Parkway Lexington, KY 40509	<b>Bid Package / Bid Date</b> #19-2022 Inductive Vehicle Loop Protection

MWDBE Company Address	Contact Person	Contact Information (work phone, Email, cell)	Date Contacted	Services to be performed	Method of Communication (email, phone meeting, ad, event etc)	Total dollars \$\$ Do Not Leave Blank (Attach Documentation)	MBE * AA HA AS NA Female	Veteran
Please see attached.								

(MBE designation / AA=African American / HA= Hispanic American/AS = Asian American/Pacific Islander/ NA= Native American)

The undersigned acknowledges that all information is accurate. Any misrepresentation may result in termination of the contract and/or be subject to applicable Federal and State laws concerning false statements and claims.

Davis H. Elliot Construction Company, Inc.  
Company

03/21/2022  
Date

  
Company Representative

Reather Keith Simpson, Sr. Vice President  
Title



# LEXINGTON

## LFUCG SUBCONTRACTOR MONTHLY PAYMENT REPORT

The LFUCG has a 10% goal plan adopted by city council to increase the participation of minority and women owned businesses in the procurement process. The LFUCG also has a 3% goal plan adopted by cited council to increase the participation of veteran owned businesses in the procurement process. In order to measure that goal LFUCG will track spending with MWDBE and Veteran contractors on a monthly basis. By the signature below of an authorized company representative, you certify that the information is correct, and that each of the representations set forth below is true. Any misrepresentation may result in termination of the contract and/or prosecution under applicable Federal and State laws concerning false statements and false claims. Please submit this form monthly to the Division of Central Purchasing/ 200 East Main Street / Room 338 / Lexington, KY 40507.

**Bid/RFP/Quote #** #19-2022 Inductive Vehicle Loop Protection

**Total Contract Amount Awarded to Prime Contractor for this Project** \_\_\_\_\_

<b>Project Name/ Contract #</b>	<b>Work Period/ From:</b>	<b>To:</b>
<b>Company Name:</b>	<b>Address:</b>	
<b>Federal Tax ID:</b>	<b>Contact Person:</b>	

Subcontractor Vendor ID (name, address, phone, email)	Description of Work	Total Subcontract Amount	% of Total Contract Awarded to Prime for this Project	Total Amount Paid for this Period	Purchase Order number for subcontractor work (please attach PO)	Scheduled Project Start Date	Scheduled Project End Date
Form acknowledged.							

By the signature below of an authorized company representative, you certify that the information is correct, and that each of the representations set forth below is true. Any misrepresentations may result in the termination of the contract and/or prosecution under applicable Federal and State laws concerning false statements and false claims.

\_\_\_\_\_  
**Company**

\_\_\_\_\_  
**Company Representative**

\_\_\_\_\_  
**Date**

\_\_\_\_\_  
**Title**



**LFUCG STATEMENT OF GOOD FAITH EFFORTS**

**Bid/RFP/Quote # #19-2022 Inductive Vehicle Loop Protection**

By the signature below of an authorized company representative, we certify that we have utilized the following Good Faith Efforts to obtain the maximum participation by MWDBE and Veteran-Owned business enterprises on the project and can supply the appropriate documentation.

\_\_\_\_\_ Advertised opportunities to participate in the contract in at least two (2) publications of general circulation media; trade and professional association publications; small and minority business or trade publications; and publications or trades targeting minority, women and disadvantaged businesses not less than fifteen (15) days prior to the deadline for submission of bids to allow MWDBE firms and Veteran-Owned businesses to participate.

\_\_\_\_\_ Included documentation of advertising in the above publications with the bidders good faith efforts package

\_\_\_\_\_ Attended LFUCG Central Purchasing Economic Inclusion Outreach event

\_\_\_\_\_ Attended pre-bid meetings that were scheduled by LFUCG to inform MWDBEs and/or Veteran-Owned Businesses of subcontracting opportunities

\_\_\_\_\_ Sponsored Economic Inclusion event to provide networking opportunities for prime contractors and MWDBE firms and Veteran-Owned businesses

\_\_\_\_\_ Requested a list of MWDBE and/or Veteran subcontractors or suppliers from LFUCG and showed evidence of contacting the companies on the list(s).

\_\_\_\_\_ Contacted organizations that work with MWDBE companies for assistance in finding certified MWBDE firms and Veteran-Owned businesses to work on this project. Those contacted and their responses should be a part of the bidder's good faith efforts documentation.

\_\_\_\_\_ Sent written notices, by certified mail, email or facsimile, to qualified, certified MWDBEs soliciting their participation in the contract not less than seven (7) days prior to the deadline for submission of bids to allow them to participate effectively.

\_\_\_\_\_ Followed up initial solicitations by contacting MWDBEs and Veteran-Owned businesses to determine their level of interest.

\_\_\_\_\_ Provided the interested MWBDE firm and/or Veteran-Owned business with adequate and timely information about the plans, specifications, and requirements of the contract.

\_\_\_\_\_ Selected portions of the work to be performed by MWDBE firms and/or Veteran-Owned businesses in order to increase the likelihood of meeting the contract goals. This includes, where appropriate, breaking out contract work items into economically feasible units to facilitate MWDBE and Veteran participation, even when the prime contractor may otherwise perform these work items with its own workforce

\_\_\_\_\_ Negotiated in good faith with interested MWDBE firms and Veteran-Owned businesses not rejecting them as unqualified without sound reasons based on a thorough investigation of their capabilities. Any rejection should be so noted in writing with a description as to why an agreement could not be reached.

\_\_\_\_\_ Included documentation of quotations received from interested MWDBE firms and Veteran-Owned businesses which were not used due to uncompetitive pricing or were rejected as unacceptable and/or copies of responses from firms indicating that they would not be submitting a bid.

\_\_\_\_\_ Bidder has to submit sound reasons why the quotations were considered unacceptable. The fact that the bidder has the ability and/or desire to perform the contract work with its own forces will not be considered a sound reason for rejecting a MWDBE and/or Veteran-Owned business's quote. Nothing in this provision shall be construed to require the bidder to accept unreasonable quotes in order to satisfy MWDBE and Veteran goals.

\_\_\_\_\_ Made an effort to offer assistance to or refer interested MWDBE firms and Veteran-Owned businesses to obtain the necessary equipment, supplies, materials, insurance and/or bonding to satisfy the work requirements of the bid proposal

\_\_\_\_\_ Made efforts to expand the search for MWBE firms and Veteran-Owned businesses beyond the usual geographic boundaries.

Other--any other evidence that the bidder submits which may show that the bidder has made reasonable good faith efforts to include MWDBE and Veteran participation.  
\* Davis H. Elliot Construction Company's affirmative action program. *RKS*

**NOTE: Failure to submit any of the documentation requested in this section may be cause for rejection of bid. Bidders may include any other documentation deemed relevant to this requirement which is subject to approval by the MBE Liaison. Documentation of Good Faith Efforts must be submitted with the Bid, if the participation Goal is not met.**

The undersigned acknowledges that all information is accurate. Any misrepresentations may result in termination of the contract and/or be subject to applicable Federal and State laws concerning false statements and claims.

Davis H. Elliot Construction Company, Inc.

**Company**

03/21/2022

**Date**



**Company Representative**

Reather Keith Simpson, Sr. Vice President

**Title**



**AMENDMENT 1 —**  
**CERTIFICATION OF COMPLIANCE FOR AMERICAN RESCUE PLAN ACT EXPENDITURES**

The Lexington-Fayette Urban County Government (“LFUCG”) may classify the subject matter of this bid as an expenditure under the American Rescue Plan Act of 2021. Expenditures under the American Rescue Plan Act of 2021 require evidence of the contractor’s compliance with Federal law. Therefore, by the signature below of an authorized company representative, you certify that the information below is understood, agreed, and correct. Any misrepresentations may result in the termination of the contract and/or prosecution under applicable Federal and State laws concerning false statements and false claims.

**The bidder agrees and understands that in addition to all conditions stated within the attached bid documents, the following conditions will also apply to any Agreement entered between bidder and LFUCG, if LFUCG classifies the subject matter of this bid as an expenditure under the American Rescue Plan Act. The bidder further certifies that it can and will comply with these conditions, if this bid is accepted and an Agreement is executed:**

1. Any Agreement executed as a result of acceptance of this bid may be governed in accordance with 2 CFR Part 200 and all other applicable Federal law and regulations and guidance issued by the U.S. Department of the Treasury.
2. Pursuant to 24 CFR 85.43, any Agreement executed as a result of acceptance of this bid can be terminated if the contractor fails to comply with any term of the award. This Agreement may be terminated for convenience in accordance with 24 CFR 85.44 upon written notice by LFUCG. Either party may terminate this Agreement with thirty (30) days written notice to the other party, in which case the Agreement shall terminate on the thirtieth day. In the event of termination, the contractor shall be entitled to that portion of total compensation due under this Agreement as the services rendered bears to the services required. Either party may terminate this Agreement for good cause shown with forty-five (45) days written notice, which shall explain the party’s cause for the termination. If the parties do not reach a settlement before the end of the 45 days, then the Agreement shall terminate on the forty-fifth day.
3. The contractor will not discriminate against any employee or applicant for employment because of race, color, religion, sex, sexual orientation, gender identity, or national origin. The contractor will take affirmative action to ensure that applicants are employed and that employees are treated during employment without regard to their race, color, religion, sex, sexual orientation, gender identity, or national origin. Such action shall include, but not be limited to the following:
  - (1) Employment, upgrading, demotion, or transfer; recruitment or recruitment advertising; layoff or termination; rates of pay or other forms of compensation; and selection for training, including apprenticeship. The contractor agrees to post in conspicuous places, available to employees and applicants for employment, notices to be provided setting forth the provisions of this nondiscrimination clause.
  - (2) The contractor will, in all solicitations or advertisements for employees placed by or on behalf of the contractor, state that all qualified applicants will receive consideration for employment without regard to race, color, religion, sex, sexual orientation, gender identity, or national origin.
  - (3) The contractor will not discharge or in any other manner discriminate against any employee or applicant for employment because such employee or applicant has inquired about, discussed, or disclosed the compensation of the employee or applicant or another employee or applicant. This provision shall not apply to instances in which an employee who has access to the compensation information of other employees or applicants as a part of such employee’s essential job functions discloses the compensation of such other employees or applicants to individuals who do not otherwise have access to such information, unless such disclosure is in response to a formal complaint or charge, in furtherance of an investigation, proceeding, hearing, or action, including an investigation conducted by the employer, or is consistent with the contractor’s legal duty to furnish information.

- (4) The contractor will send to each labor union or representative of workers with which he has a collective bargaining agreement or other contract or understanding a notice to be provided advising the said labor union or workers' representatives of the contractor's commitments under this section and shall post copies of the notice in conspicuous places available to employees and applicants for employment.
- (5) The contractor will comply with all provisions of Executive Order 11246 of September 24, 1965, and of the rules, regulations, and relevant orders of the Secretary of Labor.
- (6) The contractor will furnish all information and reports required by Executive Order 11246 of September 24, 1965, and by rules, regulations, and orders of the Secretary of Labor, or pursuant thereto, and will permit access to his books, records, and accounts by the administering agency and the Secretary of Labor for purposes of investigation to ascertain compliance with such rules, regulations, and orders.
- (7) In the event of the contractor's noncompliance with the nondiscrimination clauses of this contract or with any of the said rules, regulations, or orders, this contract may be canceled, terminated, or suspended in whole or in part, and the contractor may be declared ineligible for further government contracts or federally assisted construction contracts in accordance with procedures authorized in Executive Order 11246 of September 24, 1965, and such other sanctions may be imposed and remedies invoked as provided in Executive Order 11246 of September 24, 1965, or by rule, regulation, or order of the Secretary of Labor, or as otherwise provided by law.
- (8) The contractor will include the portion of the sentence immediately preceding paragraph (1) and the provisions of paragraphs (1) through (8) in every subcontract or purchase order unless exempted by rules, regulations, or orders of the Secretary of Labor issued pursuant to section 204 of Executive Order 11246 of September 24, 1965, so that such provisions will be binding upon each subcontractor or vendor. The contractor will take such action with respect to any subcontract or purchase order as the administering agency may direct as a means of enforcing such provisions, including sanctions for noncompliance.

Provided, however, that in the event a contractor becomes involved in or is threatened with litigation with a subcontractor or vendor as a result of such direction by the administering agency, the contractor may request the United States to enter into such litigation to protect the interests of the United States.

4. If fulfillment of the contract requires the contractor to employ mechanic's or laborers, the contractor further agrees that it can and will comply with the following:

- (1) Overtime requirements: No contractor or subcontractor contracting for any part of the contract work which may require or involve the employment of laborers or mechanics shall require or permit any such laborer or mechanic in any workweek in which he or she is employed on such work to work in excess of forty hours in such a workweek unless such laborer or mechanic receives compensation at a rate not less than one and one-half times the basic rate of pay for all hours worked in excess of forty hours in such a workweek.
- (2) Violation: liability for unpaid wages; liquidated damages. In the event of any violation of the clause set forth in paragraph (1) of this section, the contractor and any subcontractor responsible therefor shall be liable for the unpaid wages. In addition, such contractor and subcontractor shall be liable to the United States (in the case of work done under contract for the District of Columbia or a territory, to such District or to such territory) for liquidated damages. Such liquidated damages shall be computed with respect to each individual laborer or mechanic, including watchmen and guards, employed in violation of the clause set forth in paragraph (1) of this section, in the sum of \$10 for each calendar day on which such individual was required or permitted to work in excess of the standard workweek of forty hours without payment of the overtime wages required by the clause set forth in paragraph (1) of this section.
- (3) Withholding for unpaid wages and liquidated damages. LFUCG shall upon its own action or upon written request of an authorized representative of the Department of Labor withhold or cause to be withheld, from any moneys payable on account of work performed by the contractor or subcontractor under any such contract or any other federal contract with the same prime contractor, or any other federally-assisted contract

subject to the Contract Work Hours and Safety Standards Act, which is held by the same prime contractor, such sums as may be determined to be necessary to satisfy any liabilities of such contractor or subcontractor for unpaid wages and liquidated damages as provided in the clause set forth in paragraph (2) of this section.

(4) Subcontracts. The contractor or subcontractor shall insert in any subcontracts the clauses set forth in paragraph (1) through (4) of this section and also a clause requiring the subcontractors to include these clauses in any lower-tier subcontracts. The prime contractor shall be responsible for compliance by any subcontractor or lower-tier subcontractor with the clauses set forth in paragraphs (1) through (4) of this section.

5. The contractor shall comply with all applicable standards, orders, or regulations issued pursuant to the Clean Air Act, as amended, 42 U.S.C. § 7401 et seq.

6. The contractor shall report each violation to LFUCG and understands and agrees that LFUCG will, in turn, report each violation as required to assure notification to the Treasury Department and the appropriate Environmental Protection Agency Regional Office.

7. The contractor shall include these requirements in numerical paragraphs 5 and 6 in each subcontract exceeding \$100,000 financed in whole or in part with American Rescue Plan Act funding.

8. The contractor shall comply with all applicable standards, orders, or regulations issued pursuant to the Federal Water Pollution Control Act, as amended, 33 U.S.C. 1251 et seq.

9. The contractor shall report each violation to LFUCG and understands and agrees that LFUCG will, in turn, report each violation as required to assure notification to the Treasury Department and the appropriate Environmental Protection Agency Regional Office.

10. The contractor shall include these requirements in numerical paragraphs 8 and 9 in each subcontract exceeding \$100,000 financed in whole or in part with American Rescue Plan Act funds.

11. The contractor shall comply with all applicable standards, orders, or regulations issued pursuant to the Federal Water Pollution Control Act, as amended, 33 U.S.C. 1251 et seq.

12. The contractor shall report each violation to LFUCG and understands and agrees that LFUCG will, in turn, report each violation as required to assure notification to the Treasury Department and the appropriate Environmental Protection Agency regional office.

13. The contractor shall include these requirements in numerical paragraphs 11 and 12 in each subcontract exceeding \$100,000 financed in whole or in part with American Rescue Plan Act funds.

14. The contractor shall include this language in any subcontract it executes to fulfill the terms of this bid: "the subgrantee, contractor, subcontractor, successor, transferee, and assignee shall comply with Title VI of the Civil Rights Act of 1964, which prohibits recipients of federal financial assistance from excluding from a program or activity, denying benefits of, or otherwise discriminating against a person on the basis of race, color, or national origin (42 U.S.C. § 2000d et seq.), as implemented by the Department of the Treasury's Title VI regulations, 31 CFR Part 22, which are herein incorporated by reference and made a part of this contract (or agreement). Title VI also includes protection to persons with 'Limited English Proficiency' in any program or activity receiving federal financial



assistance, 42 U.S.C. § 2000d et seq., as implemented by the Department of the Treasury's Title VI regulations, 31 CFR Part 22, and herein incorporated by reference and made a part of this contract or agreement."

15. Contractors who apply or bid for an award of \$100,000 or more shall file the required certification that it will not and has not used federal appropriated funds to pay any person or organization for influencing or attempting to influence an officer or employee of any agency. Each tier certifies to the tier above that it will not and has not used federal appropriated funds to pay any person or organization for influencing or attempting to influence an officer or employee of any agency, a member of Congress, officer or employee of Congress, or an employee of a member of Congress in connection with obtaining any federal contract, grant, or any other award covered by 31 U.S.C. § 1352. Each tier shall also disclose any lobbying with non-federal funds that takes place in connection with obtaining any federal award. Such disclosures are forwarded from tier to tier, up to the recipient. The required certification is included here:

- a. The undersigned certifies, to the best of his or her knowledge and belief, that:
  - (1) No Federal appropriated funds have been paid or will be paid, by or on behalf of the undersigned, to any person for influencing or attempting to influence an officer or employee of an agency, a Member of Congress, an officer or employee of Congress, or an employee of a Member of Congress in connection with the awarding of any Federal contract, the making of any Federal grant, the making of any Federal loan, the entering into of any cooperative agreement, and the extension, continuation, renewal, amendment, or modification of any Federal contract, grant, loan, or cooperative agreement.
  - (2) If any funds other than Federal appropriated funds have been paid or will be paid to any person for influencing or attempting to influence an officer or employee of any agency, a Member of Congress, an officer or employee of Congress, or an employee of a Member of Congress in connection with this Federal contract, grant, loan, or cooperative agreement, the undersigned shall complete and submit Standard Form-LLL, "Disclosure Form to Report Lobbying," in accordance with its instructions.
  - (3) The undersigned shall require that the language of this certification be included in the award documents for all subawards at all tiers (including subcontracts, subgrants, and contracts under grants, loans, and cooperative agreements) and that all subrecipients shall certify and disclose accordingly.
- b. This certification is a material representation of fact upon which reliance was placed when this transaction was made or entered into. Submission of this certification is a prerequisite for making or entering into this transaction imposed by section 1352, title 31, U.S. Code. Any person who fails to file the required certification shall be subject to a civil penalty of not less than \$10,000 and not more than \$100,000 for each such failure.



Signature Reather Keith Simpson, Sr. Vice President

03/21/2022

Date

Bid# 19-2022 INSTALLATION OF INDUCTIVE LOOP VEHICLE DETECTORS  
SPECIFICATIONS

The Lexington Fayette Urban County Government, Division of Traffic Engineering, requests bids for a price contract to consist of furnishing and installing inductive loop vehicle detectors in the travel-way surface at the location on the plans that shall be provided or as directed by the engineer. The size of the loop, number of turns and direction of winding of the wire shall be as shown on the plans or as directed by the engineer. This bid is requested for various locations throughout the Lexington-Fayette Urban County Government area and requests for detector installation shall be on an as needed basis.

The work shall consist of furnishing the proper equipment and supplies, installation of the loop detectors and loop lead-in cables from junction boxes at the loops to the controller including all hardware needed for proper installation. The installation shall be properly tested and must meet or exceed the minimum acceptable limits as stated in the specifications herein. All work shall be performed in accordance with the specifications herein and all materials shall comply with these established regulations and any other requirements stated in the plans that shall be provided: (see attached drawing)

MATERIALS AND EQUIPMENT SHALL CONFORM TO THE STANDARDS OF:  
Institute of Transportation Engineers (I.T.E.), Revised Standard on Traffic Actuated Signal Controllers  
National Electrical Manufacturers Association (N.E.M.A.), Traffic Control System Standard TSI-1976, TS-1,  
Latest Edition, International Municipal Signal Association (I.M.S.A), Control Cable Specifications (updated)

SPECIAL PROVISIONS

The engineer or designee in charge of the project shall approve any changes in these special provisions.

Kentucky Department of Highways Standard Specifications, Latest Edition.  
National Electrical Code (N.E.C), latest edition  
*Manual on Uniform Traffic Control Devices (MUTCD)*, Latest Edition

All work shall be in compliance with the specifications herein. The contractor shall provide traffic control/safety measures during construction of this project. Traffic control methods are to comply with the *Manual on Uniform Traffic Control Devices (Temporary Traffic Control)*, Kentucky Department of Highways Regulations, and guidance from this office as appropriate.

The contractor shall complete each vehicle detector installation within (14) calendar days of receipt of the Installation Diagram. Consideration will be given for weather where safety could become compromised for either the traveling public or the contractor. Instances where loops are not installed in a timely manner will result in a total cost reduction of 5% per week for any portion of a week beyond the two week installation window. Repeated occurrences could result in termination of the contract and granting to the next low bidder.

Installation Diagrams (also referred to as loop plans) containing loop locations, curb bores and home-run route information shall be provided for each installation. The loop plans indicate the extent and general arrangement of proposed loops within an intersection. Any questions or changes due to field conditions concerning the given plans shall be directed to the engineer in charge of the project.



Existing utility locations will generally not be included on loop plans. The contractor is responsible for underground locates through the Before You Dig (811) program. Coordination or damages to other facilities shall not constitute additional cost to the Division of Traffic Engineering.

LFUCG Division of Engineering shall be notified by the contractor of any work involving excavation and/or sidewalk modifications. No fee.

Lane Blockage Permits from the Division of Traffic Engineering shall be obtained by the contractor prior to blocking lanes of traffic. No fee.

The contractor shall be responsible for restoring work area to original state upon completion and remove all dust and debris from the roadway. This shall include but is not limited to shrubs, concrete, grass, sweeping of the street, etc.

Failure of the loop within ninety (90) days of the installation, which are due to defects in materials and/or workmanship, shall be reinstalled at the expense of the contractor.

#### LOOP INSTALLATION SPECIAL PROVISIONS

The detector loops shall be installed in accordance with Kentucky Transportation Cabinet Installation Specifications, dated 2/13/2016 (see attached). Loop wire and materials shall meet or exceed KYTC Standard and Supplemental Specifications (2012) found in Section 835.

The contractor shall provide all materials needed: access enclosures (Type B, Tier 15 or equivalent), rigid steel conduit, flexible watertight conduits, LB condulets, Pull EL's, Weatherheads, FS Boxes (Deep Type), pole mount junction boxes, reducers, conduit straps, fasteners (all), cable ties (Panduit PLT-3H-D100), backer rods, loop sealant, loop lead-in cable, tape, grounding bushings, conduit couplings (compression and standard), 8M copperweld span wire, line hardware, aerial splice boots (TYCO/RAYPW 401139-000 Closure, Aerial, TRAC-A w/Bolt Fasteners Cable 0.5" - 1.25"), etc.

The intersection of saw cuts shall overlap so that the slots have full depth and a smooth bottom. Getting from the edge of the asphalt to behind the curb and gutter shall be accomplished by boring through and under the curb and gutter at the edge of the asphalt. Where shoulder is present, bore through the pavement at least 1 foot back from the pavement edge. When installing the detector loop, the weather shall be clear and dry and the sawed slot shall be completely clean of dust and debris and thoroughly dry. The driving surface shall be thoroughly swept after installation, to remove accumulated dust and/or mud.

#### Wire:

Loop wire shall be #14 AWG IMSA spec. 51-7.

Loop Lead-In cable shall be #14 AWG stranded, paired conductors, electrically shielded and conforming to IMSA 20-2 with copper shield.

#### Loop Lead-In:

Loop Lead-In wire, exclusive of shielded cable, shall be twisted with three to five turns per foot before placement in saw slot, conduit, or junction box. Unshielded loop wiring to field terminal connections of the cabinet and unshielded loop wiring in loop amplifier connector harness shall also be twisted three to five turns per foot.

#### Loops:

Loops shall be extended splice-free to the controller, pole or junction box. Loop wires shown as extended to poles or junction boxes shall be spliced into loop lead-in cable at the boxes or poles. Loop lead-in cable shall be extended splice-free from pole or junction box to controller. Splices shall conform to above note and be placed to minimize possibility of water intrusion. For all projects involving new asphalt pavement, traffic loops shall be installed in the base course of asphalt pavement just before final surface is constructed. The electrical contractor shall coordinate the installation of traffic loops with the paving contractor and Division of Traffic Engineering.

#### Loop Sealant:

BONDO P606/Pro Seal 303 adhesive slot sealant or equivalent. Sealant shall be replaced by the contractor if it washes out within 72-hours.

#### Splicing:

All splices shall be made with butt splices. All splices shall be covered with a 3M mastic pad or approved equal and then taped with a 3M brand #33 electrical tape. Mastic pad must cover at least 3 inches past each end of butt splice.

The contractor is required to label all loop lead-in cables with labels or tags that will properly identify them. The bottom wire in the slot shall be marked. The wiring or winding diagram shall be recorded on the plans and shall be confirmed by inspection at the time of installation. The cost of this shall be incidental to the cost of the installation.

#### Junction Boxes:

In-ground access enclosures shall be Type B, Tier 15 or equivalent. All conduits installed in in-ground junction boxes shall be bonded together with #6 bare copper and NEC approved connectors. The top of the enclosure must be flush to 1 inch above ground level. A drywell using #57 aggregate must be installed below the enclosure. The drywell must be 12 inches deep and extend at least 4 inches beyond the outside edge of the enclosure.

#### Inspection:

All installed loop detectors shall be inspected by an Urban County Government technician and/or engineer in charge of the project for proper installation and operation before the project is completed and payment is rendered. During the installation of loops, or at the convenience of Traffic Engineering staff, the technician shall meter the loops by test instruments capable of measuring electrical values of installed loop wires and lead-ins to measure inductance in microhenries, leakage resistance in megohms and the resistance of the conductors in ohms. Traffic Engineering reserves the right to make spot inspections during all phases of the loop installations.

An unacceptable loop installation shall be defined as follows:

Leakage to ground: Deflection of the pointer to below 5 megohms.

Loop Resistance: The resistance reading is 10% more than calculated.

Installation in accordance with Installation Diagram and Bid Specifications

Technical assistance shall be provided by an Urban County Government technician if requested by the contractor at no charge to the contractor provided it does not become a repetitive request for the same problems.

Pricing entered on "line Items" tab in IonWave as instructed below.

**INDUCTIVE LOOP VEHICLE DETECTION AND INSTALLATION  
PRICING SHEET**

Item #	Description	Unit	Unit Price	Projected Quantities over 1 year	Projected Total Bid
1	Provide and install loop wire, saw slot, and sealant in asphalt or concrete.	Lf.		100	
2	Provide and install 0.75 or 1.25 inch flexible watertight conduit under curb and gutter	Ea.		50	
3	Provide and install in-ground access enclosure	Ea.		5	
4	Provide and install rigid conduit in traffic bearing surface.	Lf.		100	
5	Provide and install rigid conduit in non-traffic bearing surface.	Lf.		200	
6	Provide and install IMSA 20-2, 3-pair, #14 stranded cable overhead.	Lf.		20	
7	Provide and install IMSA 20-2, 4-pair, #14 stranded cable overhead.	Lf.		200	
8	Provide and install IMSA 20-2, 3-pair, #14 stranded cable in conduit.	Lf.		20	
9	Provide and install IMSA 20-2, 4-pair, #14 stranded cable in conduit.	Lf.		200	
10	Provide and install conduit above ground	Lf.		50	
11	Provide and install span wire with approved hardware.	Lf.		100	
12	Connect vehicle detector in cabinet	Ea.		1	
13	Connect vehicle detector in remote access enclosure.	Ea.		1	
14	Mobilization (Charge per intersection regardless of number of loops to install)	Ea.		25	
15	Provide and install (1) 6'x20' quadrapole detector loop with up to 50' lead-in and connection (cabinet or remote enclosure).	Ea.		30	
16	Provide and install (1) 6'x30' quadrapole detector loop with up to 50' lead-in and connection (cabinet or remote enclosure).	Ea.		12	
17	Provide and install pre-formed loop wire, saw slot and sealant in asphalt or concrete.	Lf.		1	
18	Concrete sidewalk replacement	Sq-ft		30	
	Projected Totals				

Do NOT fill out this pricing sheet. This is to give you the projected quantities per year. Your pricing should be in the "Line Items" tab on Ionwave.

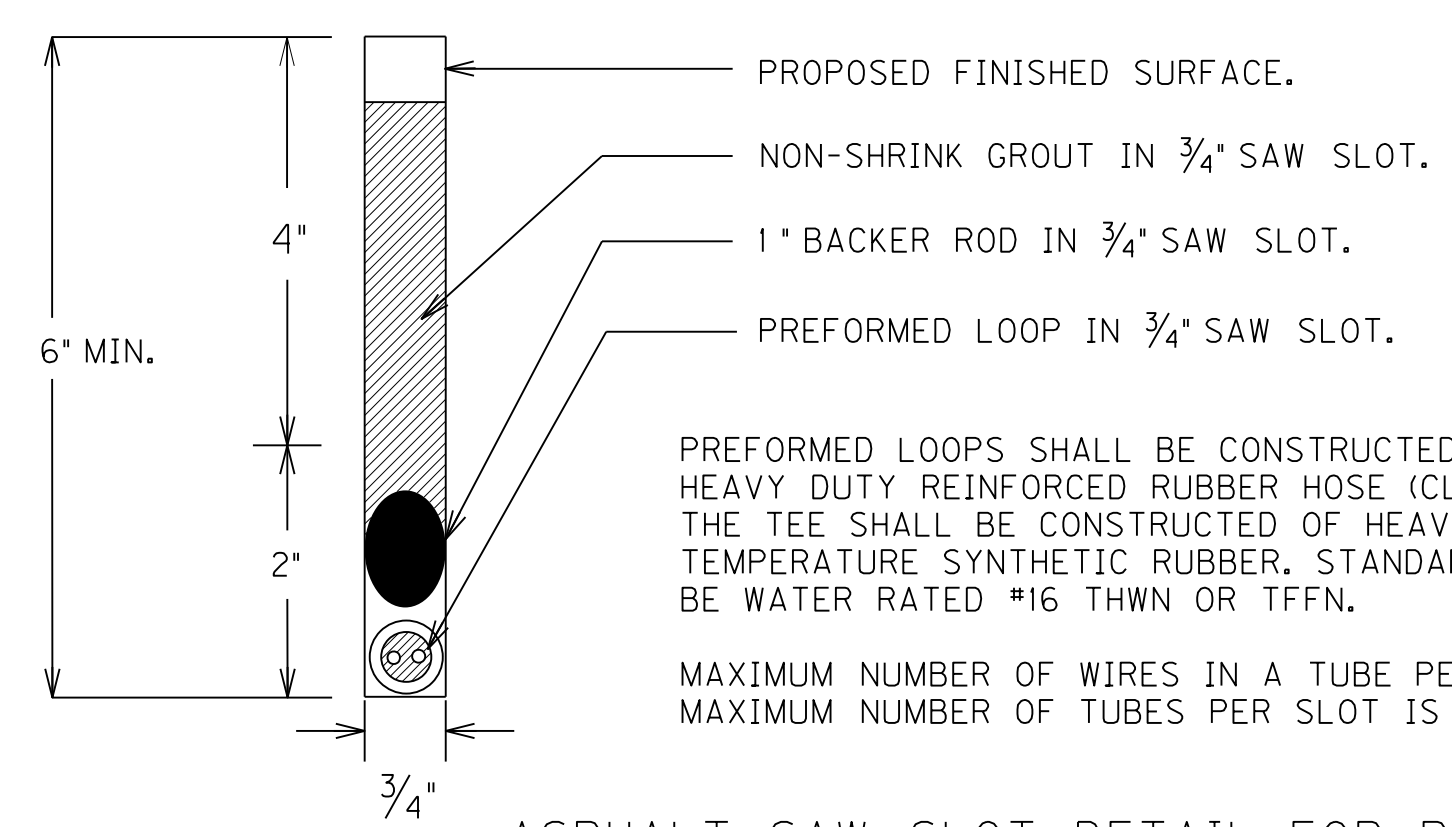
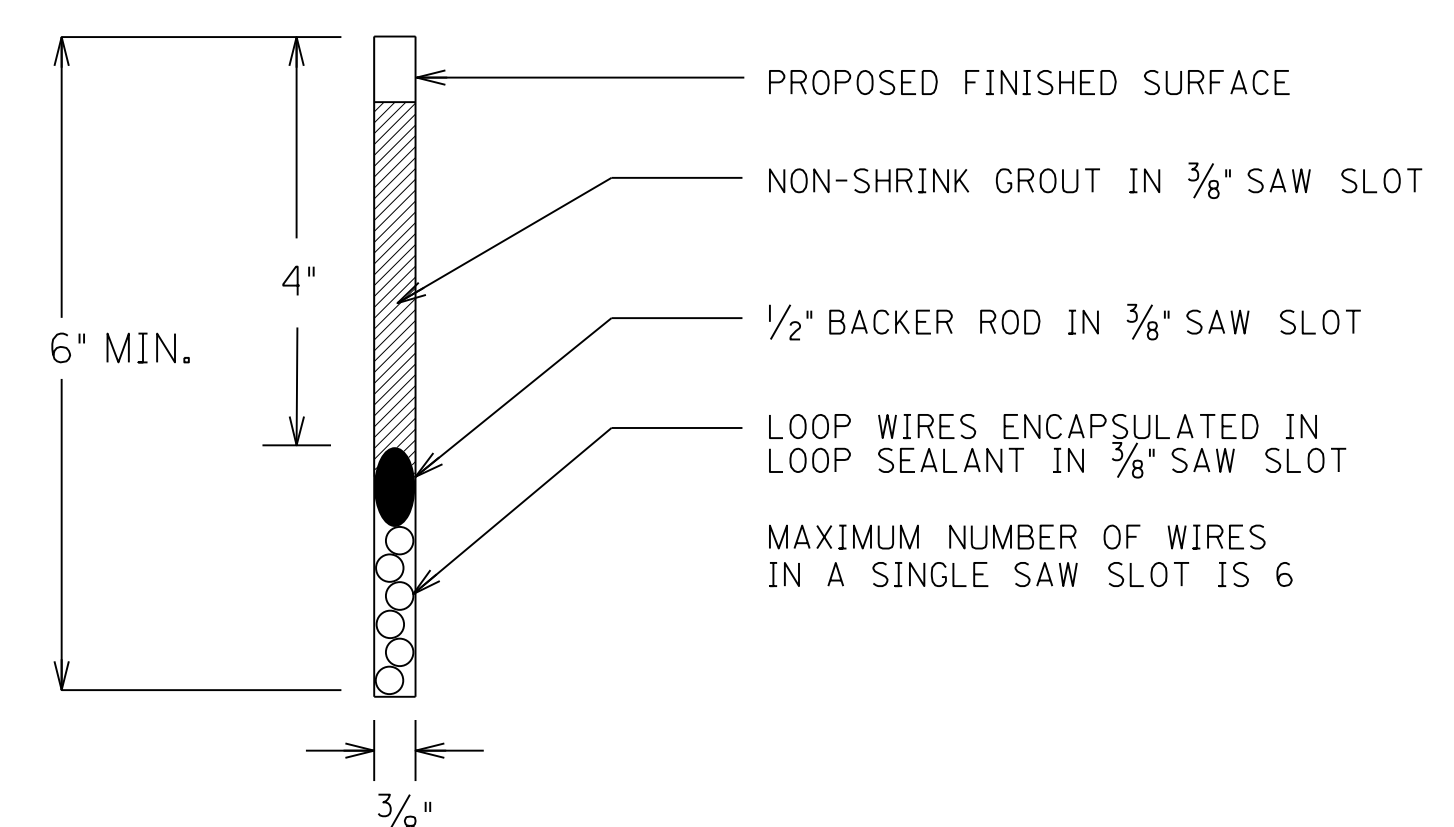

ASPHALT SAW SLOT DETAIL FOR PREFORMED  
Use detail for concrete application if concrete is 4" or less

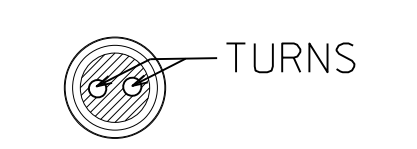

PREFORMED LOOP CROSS SECTION

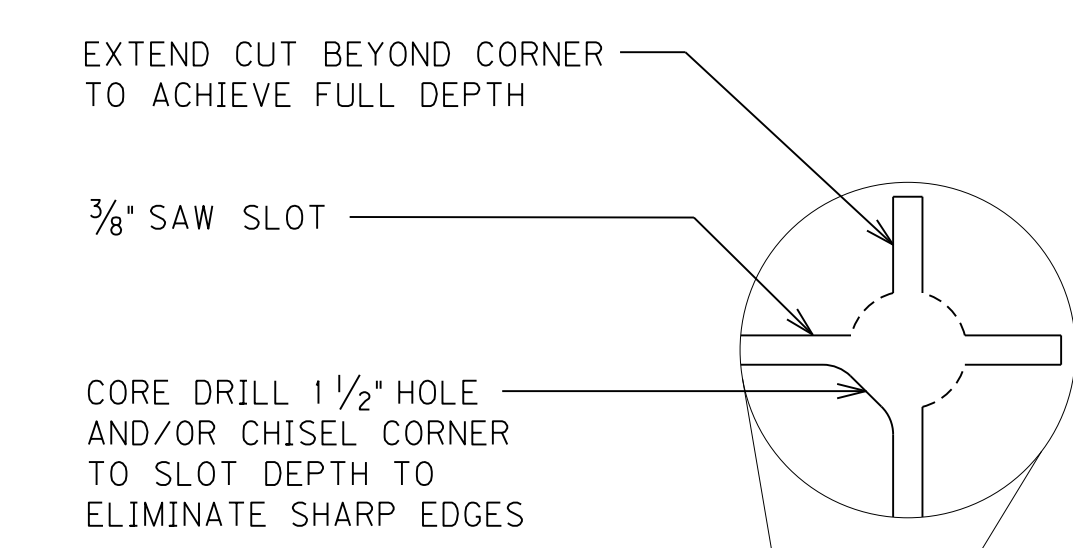

SAW CUT PLAN

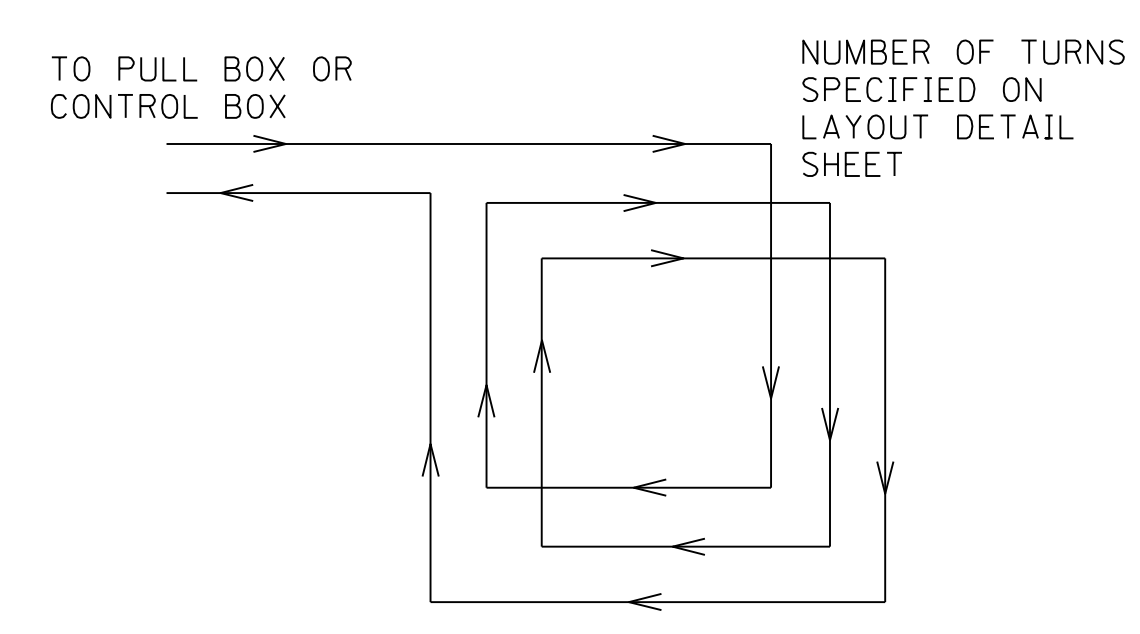

LOOP WIRE PLAN

6'x6' LOOP

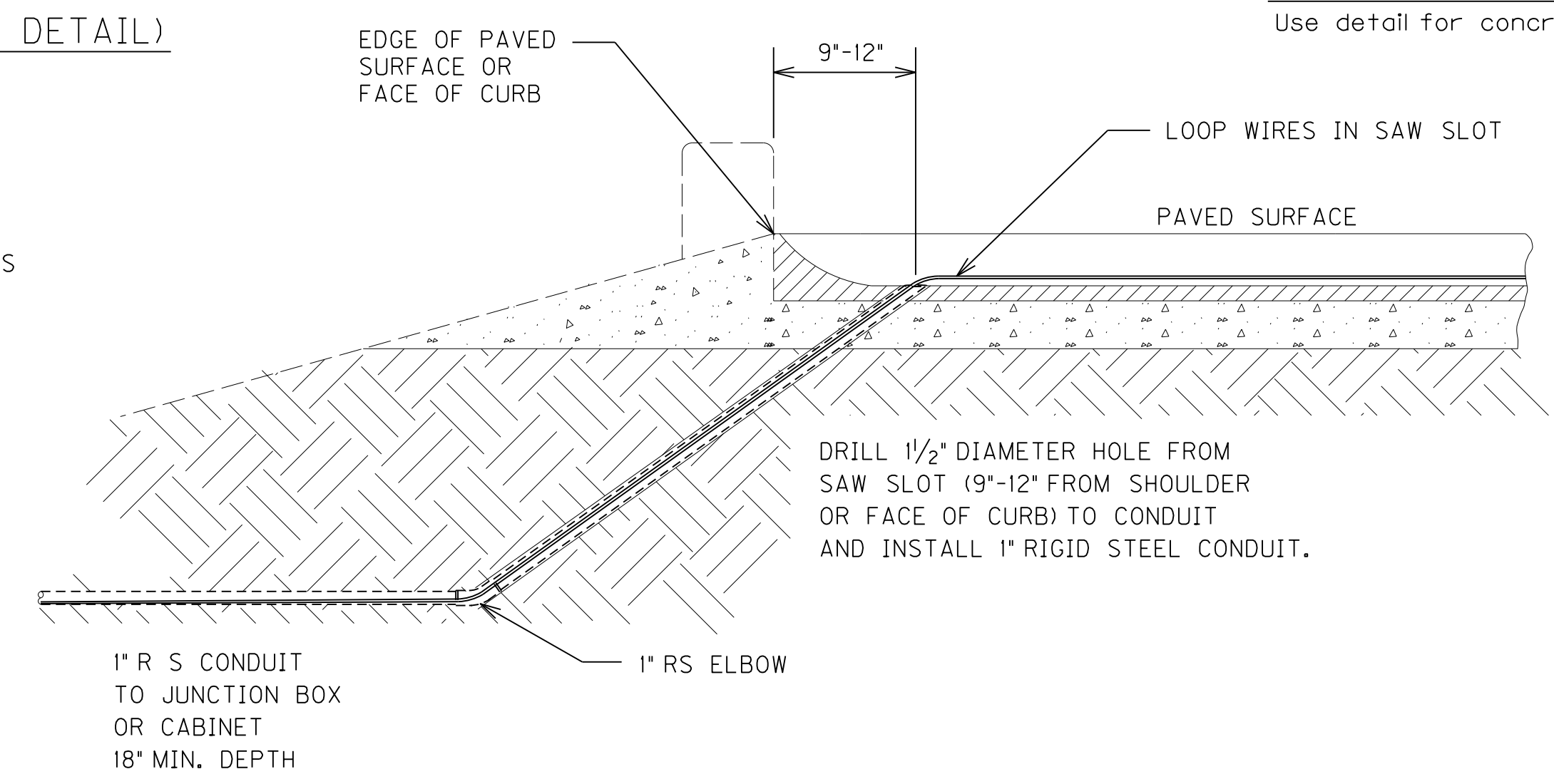

SAW SLOT EDGE OF PAVEMENT TRANSITION

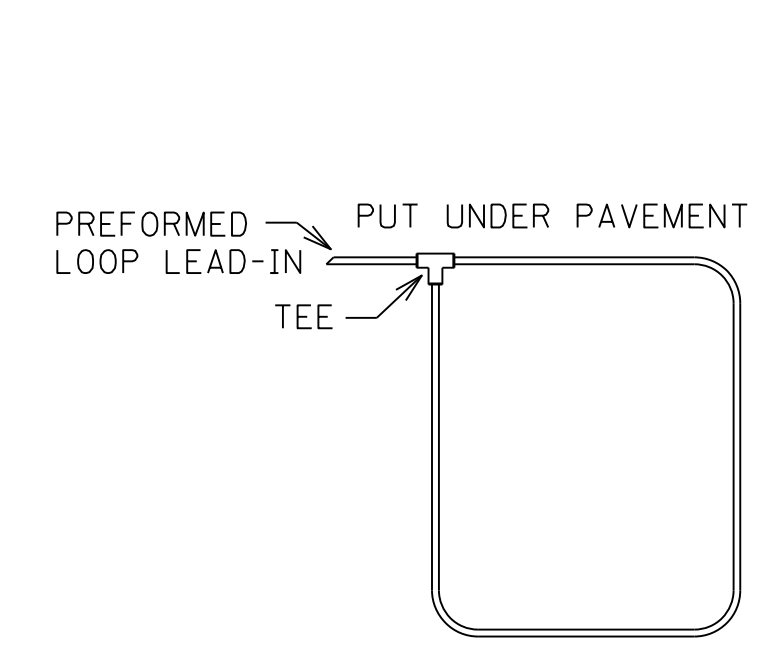

PREFORMED LOOP DIAGRAM

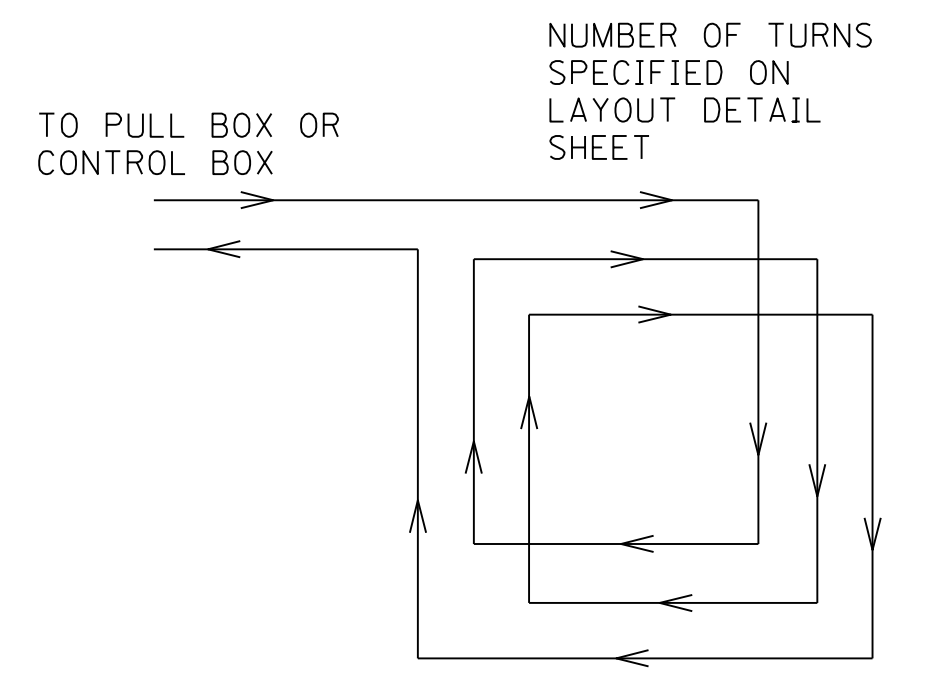

LOOP WIRE PLAN

6'x6' PREFORMED LOOP

- CONSTRUCTION DETAILS FOR LOOP SAW SLOT AND FILL BID ITEM:  
THE FOLLOWING IS A TYPICAL STEP BY STEP PROCEDURE FOR THE INSTALLATION OF A LOOP.
- CAREFULLY MARK THE SLOT TO BE CUT, PERPENDICULAR TO THE FLOW OF TRAFFIC AND CENTERED IN THE LANE.
  - MAKE EACH SAW-CUT 3/8 INCH WIDE AND AT A DEPTH SUCH THAT THE TOP OF THE BACKER ROD IS A MINIMUM OF 4 INCHES BELOW THE SURFACE OF ASPHALT PAVEMENT.
  - DRILL A 1 1/2 INCH CORE HOLE AT EACH CORNER AND USE A CHISEL TO SMOOTH THE CORNERS TO PREVENT SHARP BENDS IN THE WIRE.
  - CLEAN ALL FOREIGN AND LOOSE MATTER OUT OF THE SLOTS, DRILLED CORES, AND WITHIN 1 FOOT ON ALL SIDES OF THE SLOTS USING A HIGH PRESSURE WASHER.
  - COMPLETELY DRY THE SLOTS, DRILLED CORES, AND WITHIN 1 FOOT ON ALL SIDES OF THE SLOTS.
  - MEASURE 9-12 INCHES FROM THE EDGE OF THE PAVED SURFACE (SHOULDER BREAK OR FACE OF CURB) AND DRILL A 1 1/2 INCH HOLE ON A 45 DEGREE ANGLE TO THE CONDUIT ADJACENT TO THE ROADWAY.
  - CLOSELY INSPECT ALL CUTS, CORES, AND SLOTS FOR JAGGED EDGES OR PROTRUSIONS PRIOR TO THE PLACEMENT OF THE WIRE. ALL JAGGED EDGES AND PROTRUSIONS SHALL BE GROUND OR RE-CUT AND CLEANED AGAIN.
  - INSTALL 1" RIGID STEEL CONDUIT IN 45 DEGREE DRILLED SLOT. CONNECT CONDUIT TO 1" RIGID STEEL CONDUIT ADJACENT TO THE ROADWAY WITH RIGID STEEL ELBOW.
  - PLACE THE LOOP WIRE SPLICE-FREE FROM THE TERMINATION POINT.
  - PUSH THE WIRE INTO THE SAW SLOT WITH A BLUNT OBJECT SUCH AS A WOODEN STICK. MAKE SURE THAT THE LOOP WIRE IS PUSHED FULLY TO THE BOTTOM OF THE SAW SLOT. SCREWDRIVERS SHALL NOT BE USED.
  - INSTALL DUCT SEALANT TO A MINIMUM OF 1 INCH DEEP INTO THE CORED 1 1/2 INCH HOLE.
  - APPLY LOOP SEALANT FROM THE BOTTOM UP AND FULLY ENCAPSULATE THE LOOP WIRES IN THE SAW SLOT. THE WIRE SHOULD NOT BE ABLE TO MOVE WHEN THE SEALANT HAS SET.
  - COVER THE ENCAPSULATED LOOP WIRE WITH A CONTINUOUS LAYER OF BACKER ROD ALONG THE ENTIRE LOOP AND HOME RUN SAW SLOTS SUCH THAT NO VOIDS ARE PRESENT BETWEEN THE LOOP SEALANT AND BACKER ROD.
  - FINISH FILLING THE SAW CUT WITH NON-SHRINKABLE GROUT PER MANUFACTURER'S INSTRUCTIONS. ALLEVIATE ALL AIR POCKETS AND REFILL LOW SPACES. THERE SHALL BE NO CONCAVE PORTION TO THE GROUT IN THE SAW SLOT. ANY EXCESS GROUT SHALL BE CLEANED FROM THE ROADWAY TO ALLEVIATE TRACKING.
  - CLEAN UP THE SITE AND DISPOSE OF ALL WASTE OFF THE PROJECT.
  - ENSURE THAT THE GROUT HAS COMPLETELY CURED PRIOR TO SUBJECTING THE LOOP TO TRAFFIC. CURING TIME VARIES WITH TEMPERATURE AND HUMIDITY.

PREFORMED LOOP LEAD-IN SHALL BE TWISTED WITH THREE TO FIVE TURNS PER FOOT UNTIL TERMINATED AT FIELD CONNECTIONS IN THE CABINET OR CONNECTED TO SHIELDED CABLE.

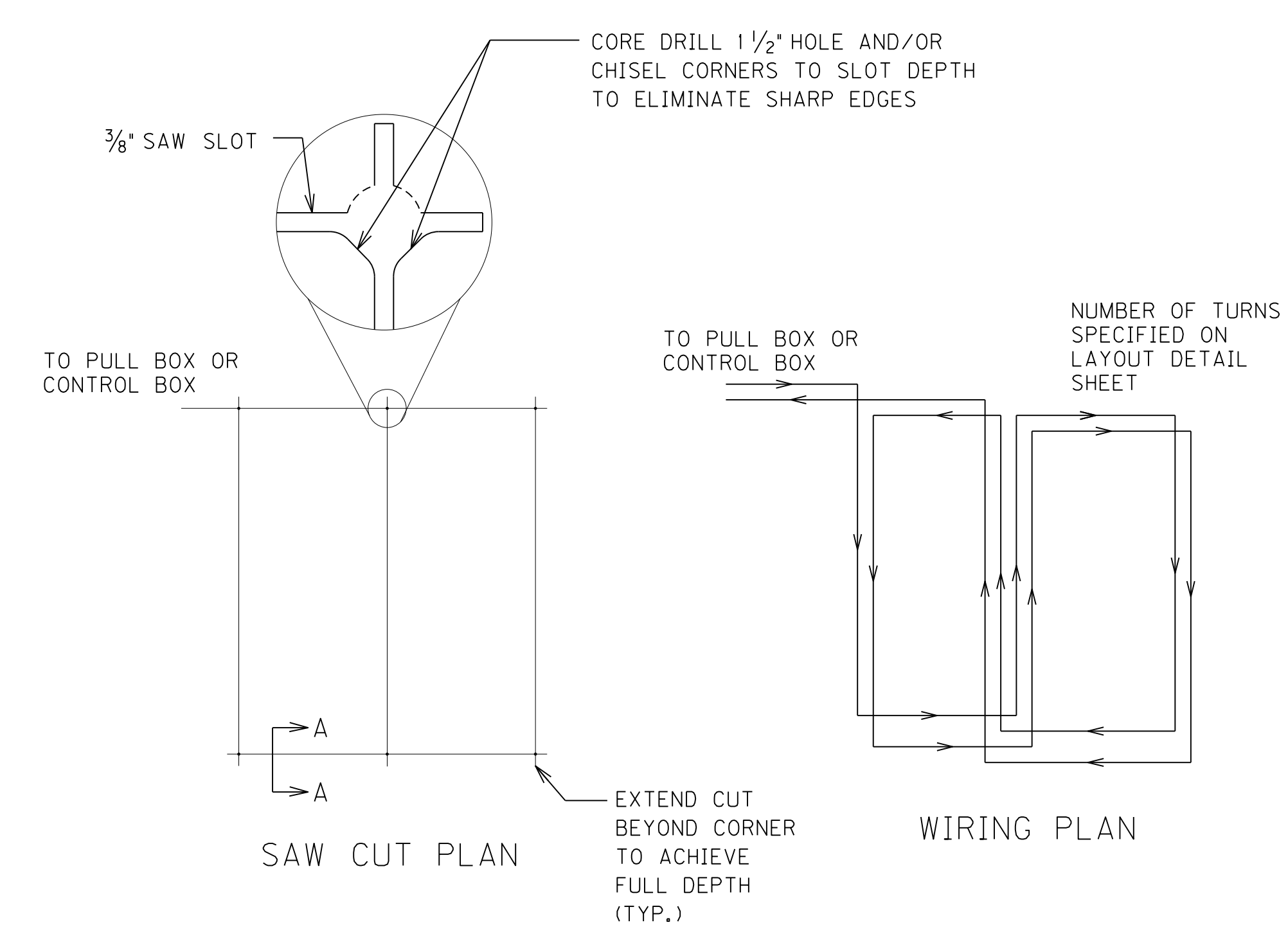

SAW CUT PLAN

WIRING PLAN

6'x30' QUADRAPOLE LOOP

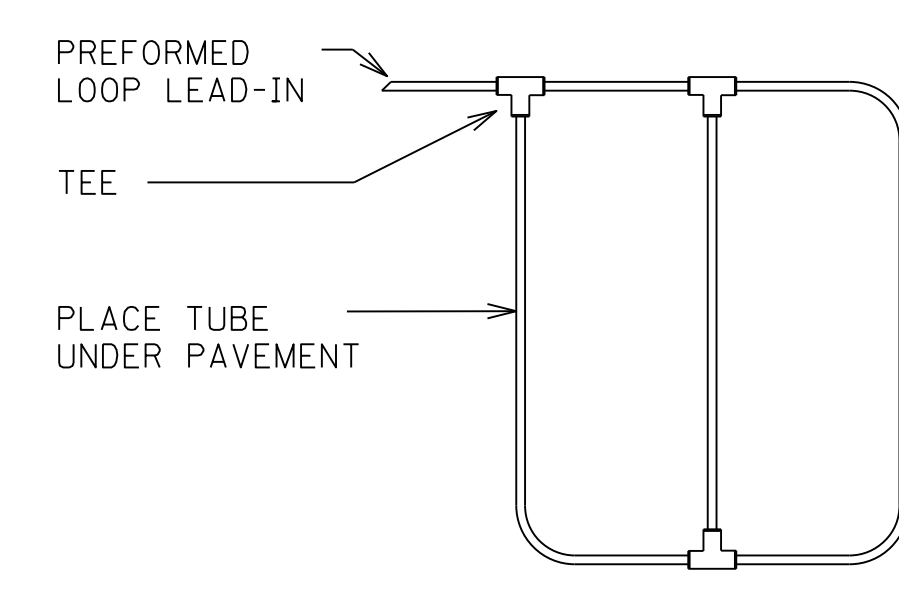

PREFORMED LOOP DIAGRAM

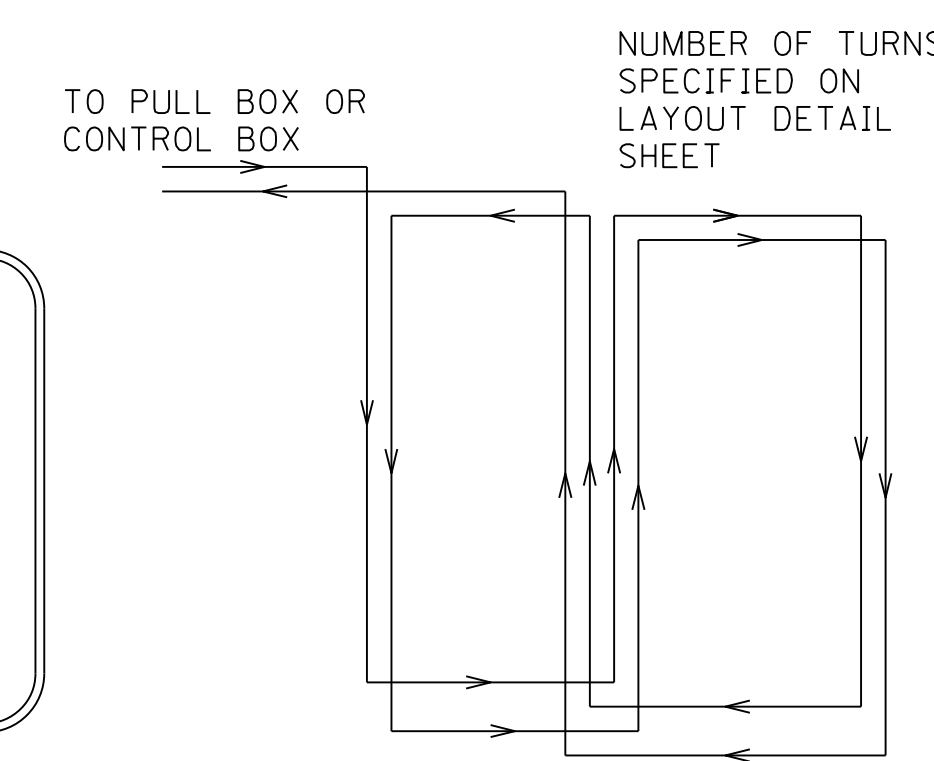

LOOP WIRE PLAN

6'x30' QUADRAPOLE PREFORMED LOOP

FILE NAME: G:\PWORK\TED.SWANEGAR\MS28756\04-LOOPS (LP).DGN  
 USER: ted.swanegor  
 DATE PLOTTED: April 26, 2016  
 E-SHEET NAME:  
 MicroStation v8.11.7.443  
 2/13/2016

**RISK MANAGEMENT PROVISIONS  
INSURANCE AND INDEMNIFICATION**

---

**A. 1.0 DEFINITIONS.**

The CONTRACTOR understands and agrees that the Risk Management Provisions of this Contract define the responsibilities of the CONTRACTOR to the OWNER.

As used in these Risk Management Provisions, the terms "CONTRACTOR" and "OWNER" shall be defined as follows:

- a. "CONTRACTOR" means the contractor and its employees, agents, servants, owners, principals, licensees, assigns and subcontractors of any tier.
- b. "OWNER" means the Lexington-Fayette Urban County Government and its elected and appointed officials, employees, agents, boards, consultants, assigns, volunteers and successors in interest.

**2.0. INDEMNIFICATION AND HOLD HARMLESS PROVISION**

CONTRACTOR shall defend, indemnify, and hold harmless OWNER from and against all liability, claims, losses, actions, costs, expenses, obligations, fines, and assessments of whatever kind, including defense costs and attorney's fees, that are in any way incidental to or connected with, or that arise or are alleged to have arisen, directly or indirectly, in whole or in part, from or by: (a) CONTRACTOR's negligent acts or intentional misconduct, or errors or omissions, in connection with the performance of this contract, (b) CONTRACTOR's performance or breach of the contract provided the claim or loss is attributable to death, illness, personal injury, or property loss or damage or loss of use, and not caused by a negligent act or omission, or the willful misconduct of the OWNER, or (c) the condition of any premises, equipment or other property being used or operated by the CONTRACTOR in connection with the performance of this contract. In the event OWNER is alleged to be liable based upon the actions or inactions of CONTRACTOR, CONTRACTOR shall defend such allegations and shall bear all costs, fees and expenses of such defense, including but not limited to, all attorneys' fees and expenses, court costs, and expert witness fees and expenses, using attorneys approved in writing by OWNER, which approval shall not be unreasonably withheld. This Indemnification and Hold Harmless Provision shall in no way be limited by any financial responsibility or insurance requirements, and shall survive the termination of this contract.

**3.0 FINANCIAL RESPONSIBILITY**

The CONTRACTOR understands and agrees that it shall, prior to final acceptance of its bid and the commencement of any work, demonstrate the ability to assure compliance with the Indemnity Agreement and other provisions of this Contract.

**4.0 INSURANCE REQUIREMENTS**

BIDDERS' ATTENTION IS DIRECTED TO THE INSURANCE REQUIREMENTS BELOW, AS BIDDERS MUST CONFER WITH THEIR RESPECTIVE INSURANCE AGENTS, BROKERS, OR CARRIERS TO DETERMINE IN ADVANCE OF BID SUBMISSION THE AVAILABILITY OF THE INSURANCE COVERAGES AND ENDORSEMENTS REQUIRED HEREIN. IF AN APPARENT LOW BIDDER FAILS TO COMPLY STRICTLY WITH THE INSURANCE REQUIREMENTS BELOW, THAT BIDDER MAY BE DISQUALIFIED FROM AWARD OF THE CONTRACT.



4.1 Required Insurance Coverage

CONTRACTOR shall procure and maintain for the duration of this contract the following or equivalent insurance policies at no less than the limits shown below and cause its subcontractors to maintain similar insurance with limits acceptable to OWNER in order to protect OWNER against claims for injuries to persons or damages to property which may arise from or in connection with the performance of the work hereunder by CONTRACTOR. The cost of such insurance shall be included in any bid:

<u>Coverage</u>	<u>Limits</u>
General Liability (Insurance Services Office Form CG 00 01)	\$1 million per occurrence, \$2 million aggregate or \$2 million combined single limit
Commercial Automobile Liability (Insurance Services Office Form CA 0001)	combined single, \$1 million per occurrence
Worker's Compensation	Statutory
Employer's Liability	\$500,000.00

The policies above shall contain the following conditions:

- a. OWNER shall be named as an additional insured in the General Liability Policy and Commercial Automobile Liability Policy.
- b. The General Liability Policy shall be primary to any insurance or self-insurance retained by OWNER.
- c. The General Liability Policy shall include a Products and Completed Operations endorsement or Premises and Operations Liability endorsement unless it is deemed not to apply by OWNER.
- d. The General Liability Policy shall include an Explosion-Collapse Underground endorsement unless it is deemed not to apply by OWNER.
- e. OWNER shall be provided at least 30 days advance written notice via certified mail, return receipt requested, in the event any of the required policies are canceled or non-renewed.
- f. Said coverage shall be written by insurers acceptable to OWNER and shall be in a form acceptable to OWNER. Insurance placed with insurers with a rating classification of no less than Excellent (A or A-) and a financial size category of no less than VIII, as defined by the most current Best's Key Rating Guide shall be deemed automatically acceptable.

4.2. Additional insurance coverage and amounts required, if any, are stated below:

NONE

4.3. Renewals

After insurance has been approved by OWNER, evidence of renewal of an expiring policy must be submitted to OWNER, and may be submitted on a manually signed renewal endorsement form. If the policy or carrier has changed, however, new evidence of coverage must be submitted in accordance with these Insurance Requirements.

#### 4.4. Deductibles and Self-Insured Programs

**IF CONTRACTOR INTENDS TO SUBMIT SELF-INSURANCE PLAN FOR BID, THIS MUST BE FORWARDED TO LEXINGTON-FAYETTE URBAN COUNTY GOVERNMENT, DIVISION OF RISK MANAGEMENT, 200 EAST MAIN STREET, LEXINGTON, KENTUCKY 40507 NO LATER THAN A MINIMUM OF FIVE (5) WORKING DAYS PRIOR TO BID OPENING DATE.**

Self-insurance programs, deductibles, and self-insured retentions in insurance policies are subject to separate approval by Lexington-Fayette Urban County Government's Division of Risk Management, upon review of evidence of CONTRACTOR'S financial capacity to respond to claims. Any such programs or retentions must provide OWNER with at least the same protection from liability and defense of suits as would be afforded by first-dollar insurance coverage. If CONTRACTOR satisfies any portion of the insurance requirements through deductibles, self-insurance programs, or self-insured retentions, CONTRACTOR agrees to provide Lexington-Fayette Urban County Government, Division of Risk Management, the following data prior to the final acceptance of bid and the commencement of any work:

- a. CONTRACTOR'S latest audited financial statement, including auditor's notes.
- b. Any records of any self-insured trust fund plan or policy and related accounting statements.
- c. Actuarial funding reports or retained losses.
- d. CONTRACTOR'S Risk Management Manual or a description of CONTRACTOR'S self-insurance and risk management program.
- e. A claim loss run summary for the previous five (5) years.
- f. Self-Insured Associations will be considered.

#### 4.5. Verification of Coverage

Prior to award of bid, CONTRACTOR agrees to furnish OWNER with all applicable Certificates of Insurance signed by a person authorized by the insurer to bind coverage on its behalf. If requested, CONTRACTOR shall provide OWNER copies of all insurance policies, including all endorsements.

#### 4.6. Right to Review, Audit and Inspect

CONTRACTOR understands and agrees that OWNER may review, audit and inspect any and all of CONTRACTOR'S records and operations to insure compliance with these Insurance Requirements.

### 5.0 **SAFETY AND LOSS CONTROL**

- 5.1. CONTRACTOR agrees to adhere to and comply with William-Steiger Act, enacted December 1970, and all other federal, state and local safety and environmental laws, regulations and ordinances. The CONTRACTOR shall provide all safeguards, safety devices and protective equipment, and take any other action necessary to protect the life, health and safety and property of all persons on the job site, the public and the owner.

- 5.2. The current Kentucky Occupational Safety and Health Standards of the Construction Industry 29 CFR Part 1926 adopted by 803 KAR 2:030 and the Kentucky Occupational Safety and Health Standard for General Industry 29 CFR Part 1910 as adopted by KAR 2:010, and as promulgated by the Kentucky Occupational Safety and Health Standards Board and as amended or modified, are hereby incorporated into and made an integral part of the Contract with full compliance the responsibility solely of the CONTRACTOR.
- 5.3. The CONTRACTOR understands and agrees that the OWNER shall be permitted, but not obligated, to inspect the work place, operations, machinery and equipment involved in this Contract and review and audit any and all CONTRACTOR'S records and documents as deemed necessary by the OWNER to assure compliance with any and all of the provisions of this Contract and maximize the protection of the OWNER. Safety on the job, however, remains solely the responsibility of the CONTRACTOR.

## 6.0 DEFINITION OF DEFAULT

CONTRACTOR understands and agrees that the failure to comply with any of these insurance, safety, or loss control provisions shall constitute default under this Contract. CONTRACTOR also agrees that OWNER may elect at its option any single remedy or penalty or any combination of remedies and penalties, as available, including but not limited to purchasing insurance and charging CONTRACTOR for any such insurance premiums purchased, or suspending or terminating this Contract.

00246607



## **Diversity and Inclusion**

### **Disabled, Minority and Women Business Enterprises**

The Davis H. Elliot Company strives to maintain an environment that values a diverse supplier base. We believe that by taking the initiative in seeking qualified suppliers, creating and increasing alliances with and purchasing from M/W/DBE's, and including our customers and consumers in our purchasing strategy, will help build thriving local communities and generate long-term growth, as well as a competitive advantage for us. We do this by offering the greatest possible opportunities for minority and women-owned businesses to contribute as suppliers, contractors, and sub-contractors in our business.

### **Mission Statement**

To create an environment that promotes meaningful business opportunities, showcase viable M/W/DBE firm capabilities, build productive partnerships and exercise effective program management, targeted towards successful integration of M/W/DBE firms within the business structure of the Markets where we work.

**DAVIS H. ELLIOT COMPANY, INC.**

P.O. Box 12108, Lexington, KY 40580-2108 / 673 Blue Sky Parkway, Lexington, KY 40509-9459  
Phone: (859) 263-5148 / Fax: (859)263-5486 / Website: [davishelliot.com](http://davishelliot.com)



### **Diverse Suppliers:**

**The vast majority of Elliot’s work is self-performed. Our diversity plan includes looking at every “non-labor” component of our cost structure to employ the use of diverse suppliers which will add value without unnecessary cost burden that would increase our cost of service to the Customer. Attached is a current listing of 2<sup>nd</sup> Tier Diverse Suppliers which Elliot utilizes.**

**Elliot actively seeks opportunities to support disadvantaged and diversity subcontractors. We advertise, recruit and otherwise encourage participation when project scope and constraints make subcontracting possible. Elliot maintains a list of suppliers, labor and equipment subcontractors, and specialized service providers in order to maximize our diversity participation.**

**Davis H. Elliot Company, Inc.**

PO Box 12108, Lexington, Kentucky 40580 • 673 Blue Sky Parkway • Lexington, Kentucky 40509  
Phone: (859) 263-5148 • Fax: (859) 263-5486 • [www.dhec.com](http://www.dhec.com)



2nd Tier Diverse Suppliers

<b>Type of Work</b>	<b>Name of Subcontractor</b>	<b>Classification</b>
Materials	ALH Construction	WBE
Auto Supplies	Baltimore Auto Supply	WBE
Materials	Bluegrass Contracting	VET
Catering	Blume's Catering	MBE
Materials	Captain Construction and Concrete	MBE
Auto Supplies	CBY Enterprises, Inc. (Tire & Tyre Co., LLC.)	MBE
Electrical services	Delta Utility Services, Inc.	WBE
Labor and equipment rental	Eco-Battery	MBE
Materials	Fox Engineering	MBE
Equipment rental	GDM	MBE
Safety consulting	Glenn Smith	WBE
Electrical supply	Gould Electric	MBE
Waste management	Hall Enterprises (dba Logistics Planning Services)	WBE
Traffic Control	Highway Safety Inc.	WBE
Office furniture	Hurst Office Suppliers	WBE
Lodging	Innovative Solutions	WBE
Landscaping	Kimberly Inc.	WBE
Rubber gloves & sleeves	Kinmar	WBE
Equipment rental	Lorenzo Construction Co, LLC	MBE
Materials	Lyndco Inc.	WBE
Security services	Mid-Atlantic Security Agency	MBE
Janitorial services	My Cleaning Service	MBE
Electrical supply	Old Dominion Electric Supply	MBE
Pavement marking	Payne's Parking Designs	MBE
Heating oil	Phoenix Petroleum	MBE
Electrical supply	Precision Contracting	WBE
Office supplies	Rudolph's Office & Computer	WBE
Traffic Control	Safety Caution Equipment	MBE
Materials	Shepaul Enterprises	MBE
Traffic Control	Superior Pavement Markings, Inc.	MBE
Traffic signs	TKM, Inc.	WBE
Equipment rental	TNE Global	MBE
Materials	Toni Levy & Associates (DBA Levy's construction and Building)	MBE
Electrical services	Tucker Construction Group Inc.	MBE
Electrical supply	United American Supply LLC	MBE
Electrical supply	Warrior Supply	MBE
Delivery Svcs./Hauling/Fuel/ Equipment rental/Lodging	Xpress Management Solutions	MBE
Delivery Svcs.	Xpress Solutions	MBE