

**LEXINGTON-FAYETTE URBAN COUNTY GOVERNMENT
 CONTRACT CHANGE ORDER**

Page 1 of 2

To (Contractor):

Gilpin Masonry Construction Company, Inc.
 100 Sea Otter Circle
 Midway, KY 40347

Date:	November 27, 2017
Project:	Morton House Improvements
Location:	530 North Limestone
Contract No.	567-2017
Original Contract Amt.	\$43,000.00
Cumulative Amount of Previous Change Orders	\$0.00
Percent Change - Previous Change Orders	0.00%
Total Contract Amount Prior to this Change Order	\$43,000.00
Change Order No.	1

You are hereby requested to comply with the following changes from the contract plans and specification:

Current Change Order

Item No.	Description of changes-quantities, unit prices, change in completion date, etc.	Increase in contract price	Decrease in contract price
1	New post caps to replace damaged ones	\$690.00	\$0.00
2	Credit for electrical work	\$0.00	\$1,453.00
3	Sonotube construction of posts ILO rebuilding brick	\$0.00	\$2,920.00
4	Repair of masonry walls at daycare play area	\$4,745.00	\$0.00
	Total decrease		\$4,373.00
	Total increase	\$5,435.00	
	Net Amount of this Change Order		\$1,062.00
	New Contract Amount Including this Change Order		\$44,062.00
	Percent Change - This Change Order		2.47%
	Percent Change - All Change Orders		2.47%

The time provided for the completion in the contract and all provisions of the contract will apply hereto.

Recommended by	<i>[Signature]</i>	(Project Manager)	Date	11/27/17
Reviewed / Accepted by	<i>[Signature]</i>	(Consultant)	Date	11/27/17
Accepted by	<i>[Signature]</i>	(Contractor)	Date	11-27-17
Approved by	<i>[Signature]</i>	(Director)	Date	11-27-17
Approved by	<i>[Signature]</i>	(Commissioner)	Date	11-27-17
Approved by	<i>[Signature]</i>	(Mayor or CAO)	Date	DEC 07 2017

JUSTIFICATION FOR CHANGE

PROJECT: Morton House Improvements

CONTRACT NO. 567-2017

CHANGE ORDER #: 1

1. Necessity for change: Credit for the city to provide and install all conduit and connections as needed for electrical service to the storage container in the *credit* amount of \$1,453.00. After review with Bettie Kerr, a credit was given for using a sonotube for the structure of the gate posts in lieu of relaying the posts entirely out of brick for a *credit* of \$2,920.00. New stone caps to replace broken/damaged stone caps for the gate posts for \$690.00. Replace damaged block and tuckpoint and caulk in the play area at the daycare portion of The Nest for \$4,745.00. No additional days to the construction schedule.
2. Is proposed change an alternate bid? ___ Yes X No
3. Will proposed change alter the physical size of the project? ___ Yes X No
If "Yes", explain.
4. Effect of this change on other prime contractors: N/A
5. Has consent of surety been obtained? ___ Yes X Not Necessary
6. Will this change affect expiration or extent of insurance coverage? ___ Yes X No
If "Yes", will the policies be extended? ___ Yes ___ No
7. Effect on operation and maintenance costs: N/A
8. Effect on contract completion date: No additional days to the construction schedule



Mayor

DEC 07 2017

Date

Gilpin Masonry

Gilpin Masonry Construction Company Inc.
100 Sea Otter Circle
Midway Kentucky 40347

gilpinmasonry.com
Phone/Fax 502-863-2940
Cell 859-621-6416
emanuel@gilpinmasonry.com

November 22, 2017

Lexington Fayette Urban County Government
200 East Main Street
Lexington, Kentucky

Fitzsimmons Office of Architecture
112 West Third Street
Lexington, Kentucky 40507

Re: Request for Change Order to Morton House Improvements
Bid #103-2017, Resolution #567-2017

DEDUCTION:

Deduction from original contract of \$1,453.00 for the city to provide and install all of the conduit and connections as needed for the electrical service to the container unit. Gilpin Masonry will dig the ditch between the pad and the building.

Deduct the cost of laying the brick on the columns, \$2,350.00 for labor and \$570.00 for materials. Total deduction \$2,920.00

ADDITION:

Add to the cost of the contract for providing one additional stone beneath the caps the city has in storage. The plans asked that we provide one new stone but it was later discovered that two new stones are needed. The cost of this new stone is \$690.00. Installation was included in the original bid.

Add to the cost of the contract for replacing damaged block in the play area as well as minor tuckpointing and caulking replacement. This will be an additional cost of \$4,745.00

SUMMARY:

This change order will result in a net addition to the contract of \$1,062.00

Emanuel Gilpin

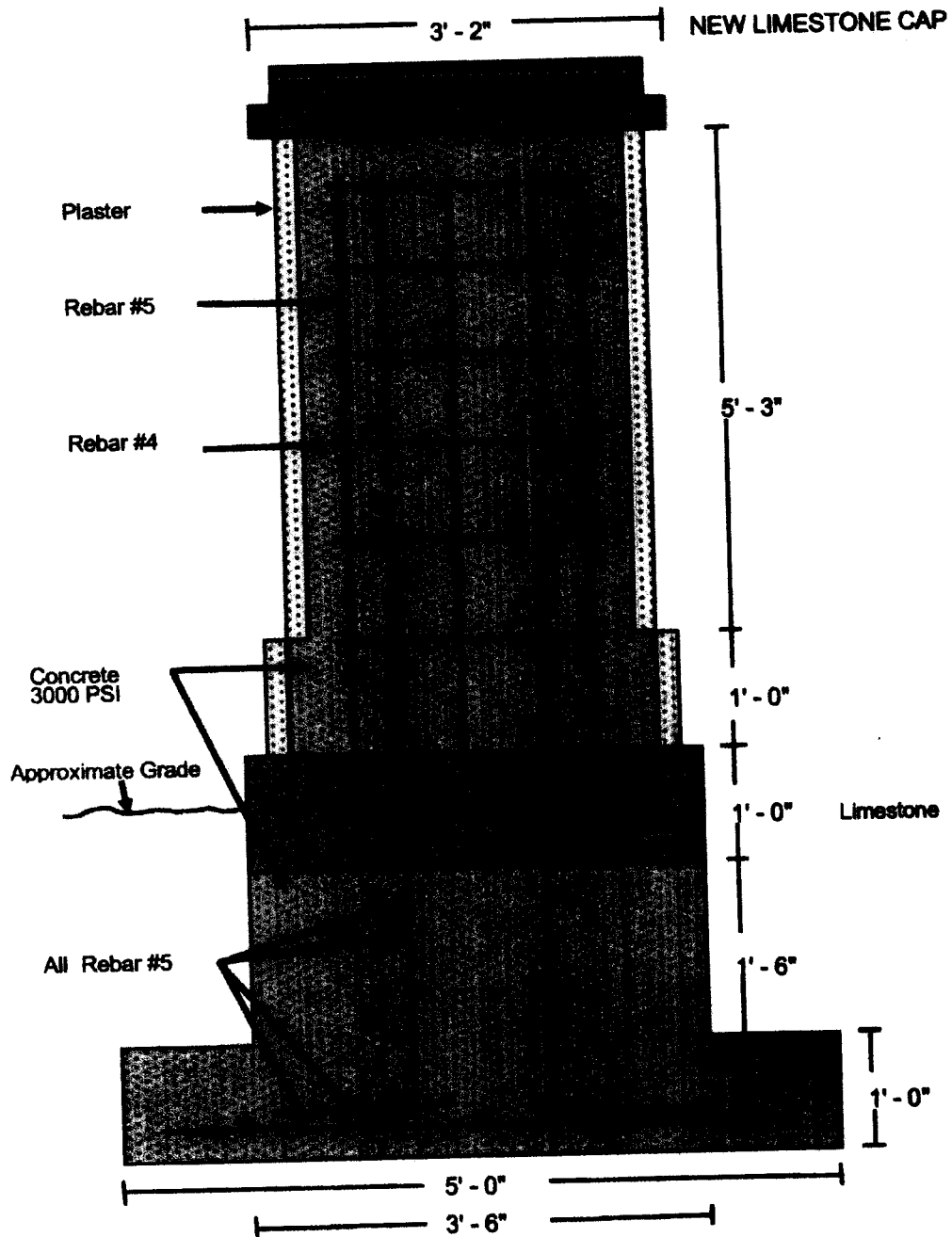

**GATEPOST REHABILITATION
530 NORTH LIMESTONE**

SHOP DRAWING FOR GILPIN MASONRY
SUBMITTED NOVEMBER 14, 2017

Emanuel T. Gilpin II

ICS Cut Ticket:

Job:

Gilpin Masonry

Stone: Buff

Date:

10-17-17

Ships:

Length	Breadth	Height	Cube
38"	38"	3 3/4"	

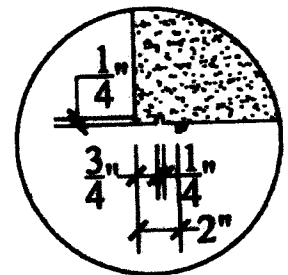
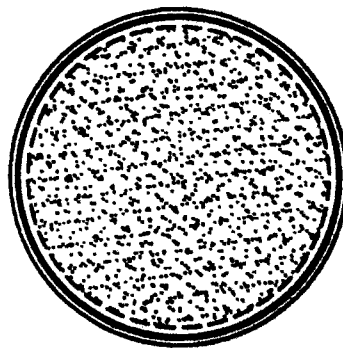
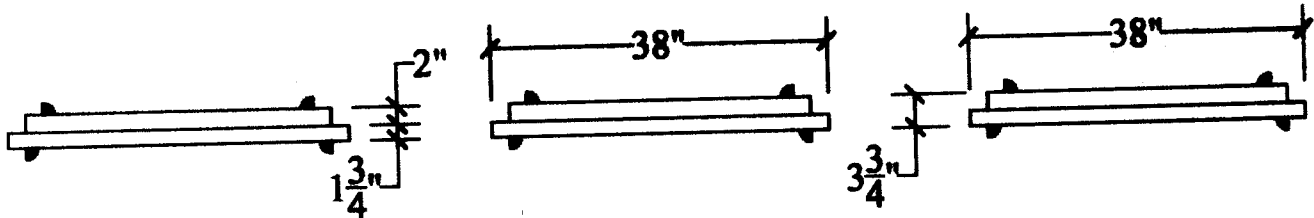
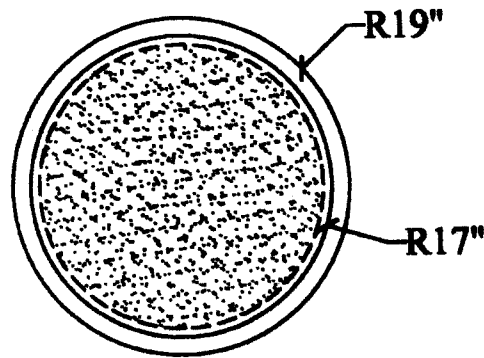

DRIP
DETAIL

Quantity

2

Truck No.

ONE &
ONLY

Ticket No.

A-1

**GATEPOST REHABILITATION
530 NORTH LIMESTONE**

SHOP DRAWING FOR GILPIN MASONRY
SUBMITTED NOVEMBER 14, 2017

Emanuel T Gilpin II

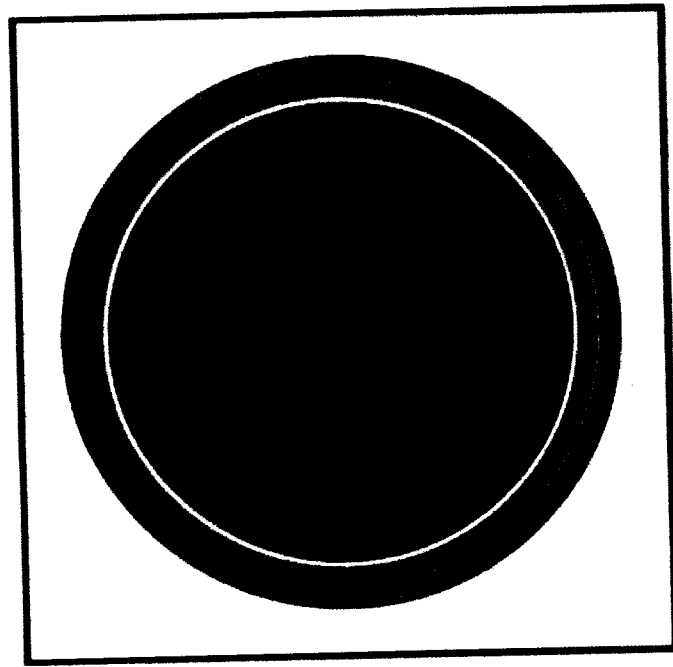

3' - 6"

- OUTSIDE DIMENSION OF STONE FOUNDATION
- OUTSIDE DIMENSION OF PLASTER
- 30" DIAMETER SONOTUBE
- REBAR CAGE (VERTICAL BARS #5 HORIZONTAL BARS #4)
- OUTSIDE DIMENSION OF BASE RING OF PLASTER

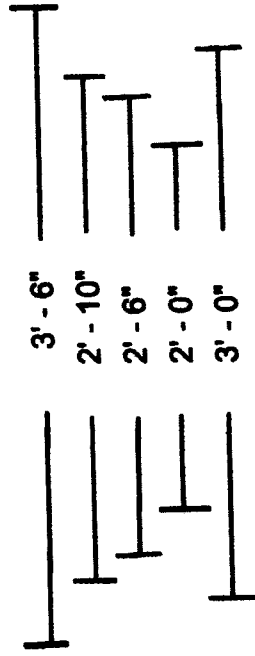

COLUMN TOP VIEW

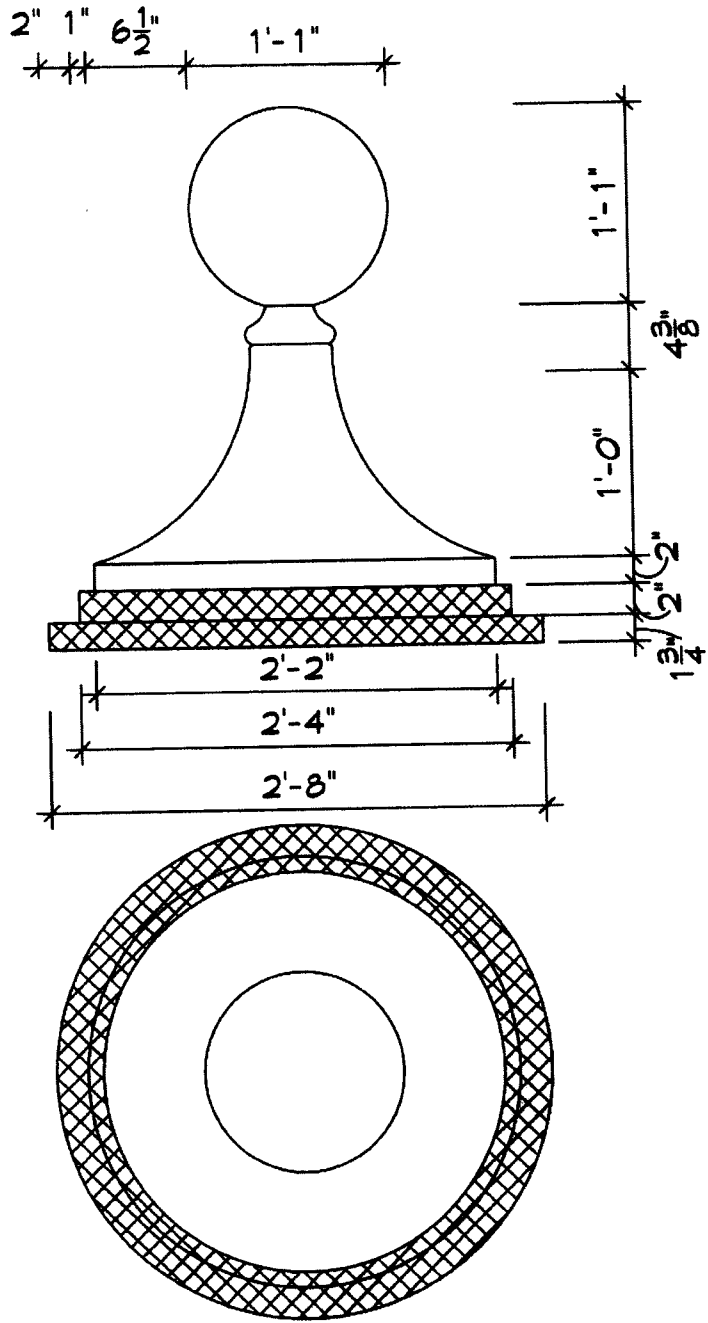

5
A2

Limestone Caps





TO: Mayor Jim Gray
Urban County Council

FROM:  (for Comm Reed)
Geoffrey Reed, Commissioner, General Services

CC: Jamshid Baradaran, Director, Facilities and Fleet Management
Jessica Walker, Project Program Manager, General Services
Sandra Lopez, Administrative Officer Sr, General Services

DATE: November 27, 2017

SUBJECT: Request a Resolution authorizing the Mayor, on behalf of the Urban County Government, to execute Change Order No. One (1) to the Contract with Gilpin Masonry Construction Company, Inc., for the Morton House Improvements Project, increasing the contract price in the amount of \$1,062.00 from \$43,000.00 to \$44,062.00 with no extension to the construction schedule.

Request

Authorization to: Execute Change Order #1 with Gilpin Masonry Construction Company, Inc. in the amount of \$1,062.00 with no extension to the construction schedule for the Morton House Improvements Project Contract #567-2017. The new contract amount including this change order is \$44,062.00.

Why are you requesting? Necessity for change: Credit for the city to provide and install all conduit and connections as needed for electrical service to the storage container in the *credit* amount of \$1,453.00. After review with Bettie Kerr, a credit was given for using a sonotube for the structure of the gate posts in lieu of relaying the posts entirely out of brick for a *credit* of \$2,920.00. New stone caps to replace broken/damaged stone caps for the gate posts for \$690.00. Replace damaged block and tuckpoint and caulk in the play area at the daycare portion of The Nest for \$4,745.00. No additional days to the construction schedule.

Department needs this action completed because: To adjust the contract as required for construction.

What is the cost in this budget year and future budget years?

The cost for this FY is: \$1,062.00

The cost for future FY is: N/A



Are the funds budgeted?

The funds are budgeted or a budget amendment is in process: **Budgeted**

Account number:

FUND	DEPT ID	SECTION	ACCOUNT	BUDGET REF	AMOUNT
1101	707201	0001	76101	2017	\$1,062.00

File Number:

Gilpin Masonry Construction Company, Inc. Contract #567-2017

Commissioner/ Director:

Geoffrey Reed, Commissioner, General Services
Jamshid Baradaran, Director, Facilities and Fleet Management

