



# LEXINGTON

## **Bid 49-2023 Addendum 4 TRIBUTE CONTRACTING Supplier Response**

### **Event Information**

Number: Bid 49-2023 Addendum 4  
Title: Wolf Run F Trunk  
Type: Competitive Bid  
Issue Date: 5/9/2023  
Deadline: 6/13/2023 02:00 PM (ET)

### **Contact Information**

Contact: Brian Marcum  
Address: Central Purchasing  
Government Center Building  
200 East Main Street  
Lexington, KY 40507  
Phone: (859) 2583320  
Fax: (859) 2583322  
Email: [brianm@lexingtonky.gov](mailto:brianm@lexingtonky.gov)

## TRIBUTE CONTRACTING Information

Address: 2125 COUNTY ROAD 1  
SOUTH POINT, OH 45680  
Phone: (740) 451-1010

ONLY ONLINE BIDS WILL BE ACCEPTED! By submitting your response, you certify that you are authorized to represent and bind your company and that you agree to all bid terms and conditions as stated in the attached bid/RFP/RFQ/Quote/Auction documents.

Todd Harrah

Signature

Submitted at 6/13/2023 11:33:56 AM (ET)

tharrah88@yahoo.com

Email

## Response Attachments

### LFUCG Wolf Run Trunk F Sewer Bid Proposal.pdf

Addendums, bid bond, proposal and all requirements including DBE documentation.

## Bid Lines

1	Mobilization	Quantity: <u>1</u> UOM: <u>LS</u>	Price: <input type="text" value="\$81,000.00"/>	Total: <input type="text" value="\$81,000.00"/>
2	Bonds and Insurance	Quantity: <u>1</u> UOM: <u>LS</u>	Price: <input type="text" value="\$83,000.00"/>	Total: <input type="text" value="\$83,000.00"/>
3	General Requirements	Quantity: <u>1</u> UOM: <u>LS</u>	Price: <input type="text" value="\$467,000.00"/>	Total: <input type="text" value="\$467,000.00"/>
4	Demobilization	Quantity: <u>1</u> UOM: <u>LS</u>	Price: <input type="text" value="\$8,000.00"/>	Total: <input type="text" value="\$8,000.00"/>
5	Erosion and Sediment Control and Conformance with SWPPP	Quantity: <u>1</u> UOM: <u>LS</u>	Price: <input type="text" value="\$24,000.00"/>	Total: <input type="text" value="\$24,000.00"/>
6	Clearing and Grubbing	Quantity: <u>1</u> UOM: <u>LS</u>	Price: <input type="text" value="\$75,000.00"/>	Total: <input type="text" value="\$75,000.00"/>
7	Tree Protection	Quantity: <u>555</u> UOM: <u>LF</u>	Price: <input type="text" value="\$3.00"/>	Total: <input type="text" value="\$1,665.00"/>
8	PVC (SDR) 35 Gravity Sewer Lateral (In Pavement)	Quantity: <u>9</u> UOM: <u>EA</u>	Unit Price: <input type="text" value="\$5,800.00"/>	Total: <input type="text" value="\$52,200.00"/>
9	PVC (SDR) 35 Gravity Sewer Lateral (Not in Pavement)	Quantity: <u>13</u> UOM: <u>EA</u>	Unit Price: <input type="text" value="\$3,800.00"/>	Total: <input type="text" value="\$49,400.00"/>

1 0	Install Cleanout	Quantity: <u>22</u> UOM: <u>EA</u>	Unit Price: <input type="text" value="\$850.00"/>	Total: <input type="text" value="\$18,700.00"/>
1 1	Tee Fittings for Gravity Sewer Lateral Connection (Non-Ductile Iron or Inserta Tee)	Quantity: <u>22</u> UOM: <u>EA</u>	Unit Price: <input type="text" value="\$450.00"/>	Total: <input type="text" value="\$9,900.00"/>
1 2	8-Inch Gravity Sewer Pipe, <6-Foot Depth, (DIP, PVC)	Quantity: <u>259</u> UOM: <u>LF</u>	Price: <input type="text" value="\$233.00"/>	Total: <input type="text" value="\$60,347.00"/>
1 3	21-Inch Gravity Sewer Pipe, <6-Foot Depth (DIP, PVC, FRP)	Quantity: <u>388</u> UOM: <u>LF</u>	Price: <input type="text" value="\$298.00"/>	Total: <input type="text" value="\$115,624.00"/>
1 4	21-Inch Gravity Sewer Pipe, 6.1-Foot to 10.0-Foot Depth (DIP, PVC, FRP)	Quantity: <u>1513</u> UOM: <u>LF</u>	Price: <input type="text" value="\$333.00"/>	Total: <input type="text" value="\$503,829.00"/>
1 5	21-Inch Gravity Sewer Pipe, 10.1-Foot to 15.0-Foot Depth (DIP, PVC, FRP)	Quantity: <u>489</u> UOM: <u>LF</u>	Price: <input type="text" value="\$362.00"/>	Total: <input type="text" value="\$177,018.00"/>
1 6	21-Inch Gravity Sewer Pipe, 15.1-Foot to 20.0-Foot Depth (DIP, PVC, FRP)	Quantity: <u>159</u> UOM: <u>LF</u>	Price: <input type="text" value="\$440.00"/>	Total: <input type="text" value="\$69,960.00"/>
1 7	21-Inch Gravity Sewer Pipe, > 20.1-Foot Depth (DIP, PVC, FRP)	Quantity: <u>12</u> UOM: <u>LF</u>	Price: <input type="text" value="\$500.00"/>	Total: <input type="text" value="\$6,000.00"/>
1 8	"Tunnel Line Segment P-8, Harrodsburg Road, 331± Linear Feet of 36-Inch Minimum Casing Size With a 21-Inch Carrier Pipe. Guided Bore and Jack (GB&J)."	Quantity: <u>1</u> UOM: <u>LS</u>	Price: <input type="text" value="\$690,000.00"/>	Total: <input type="text" value="\$690,000.00"/>
1 9	Tunnel Line Segment P-10, Wolf Run Creek, 141± Linear Feet of 36-Inch Minimum Casing Size With a 21-Inch Carrier Pipe. Guided Bore and Jack (GB&J).	Quantity: <u>1</u> UOM: <u>LS</u>	Price: <input type="text" value="\$323,000.00"/>	Total: <input type="text" value="\$323,000.00"/>
2 0	"Tunnel Line Segment P-21, Southbend Road, 63± Linear Feet of 36-Inch Minimum Casing Size With a 21-Inch Carrier Pipe. Guided Bore and Jack (GB&J)."	Quantity: <u>1</u> UOM: <u>LS</u>	Price: <input type="text" value="\$190,000.00"/>	Total: <input type="text" value="\$190,000.00"/>
2 1	Tunnel Line Segment P27, Lafayette Parkway, 331± Linear Feet of 36-Inch Minimum Casing Size With a 21-Inch Carrier Pipe. Guided Bore and Jack (GB&J).	Quantity: <u>1</u> UOM: <u>LS</u>	Price: <input type="text" value="\$652,000.00"/>	Total: <input type="text" value="\$652,000.00"/>
2 2	Connection to Existing Sewer, 18-Inches	Quantity: <u>2</u> UOM: <u>EA</u>	Unit Price: <input type="text" value="\$5,000.00"/>	Total: <input type="text" value="\$10,000.00"/>

2 3	Manhole Abandonment	Quantity: <u>  9  </u> UOM: <u> EA </u>	Unit Price: <input type="text" value="\$1,000.00"/>	Total: <input type="text" value="\$9,000.00"/>
2 4	Standard Manhole, 4-Foot Diameter, 0-Foot to 6.0-Foot Depth	Quantity: <u> 21 </u> UOM: <u> EA </u>	Unit Price: <input type="text" value="\$5,400.00"/>	Total: <input type="text" value="\$113,400.00"/>
2 5	Manhole Vertical Foot (VF), 4-Foot Diameter (Standard)	Quantity: <u> 90 </u> UOM: <u> VF </u>	Price: <input type="text" value="\$220.00"/>	Total: <input type="text" value="\$19,800.00"/>
2 6	Drop Manhole, 4-Foot Diameter, 0-Foot to 6.0-Foot Depth	Quantity: <u>  5 </u> UOM: <u> EA </u>	Unit Price: <input type="text" value="\$8,200.00"/>	Total: <input type="text" value="\$41,000.00"/>
2 7	Manhole Vertical Foot (VF), 4-Foot Diameter (Drop)	Quantity: <u> 27 </u> UOM: <u> VF </u>	Price: <input type="text" value="\$300.00"/>	Total: <input type="text" value="\$8,100.00"/>
2 8	Drop Manhole, 5-Foot Diameter, 0-Foot to 6.0-Foot Depth	Quantity: <u>  1 </u> UOM: <u> EA </u>	Unit Price: <input type="text" value="\$9,000.00"/>	Total: <input type="text" value="\$9,000.00"/>
2 9	Manhole Vertical Foot (VF), 5-Foot Diameter (Int. Drop)	Quantity: <u> 16 </u> UOM: <u> VF </u>	Price: <input type="text" value="\$300.00"/>	Total: <input type="text" value="\$4,800.00"/>
3 0	Internal Manhole Drop Connection, 8-Inch Diameter	Quantity: <u>  1 </u> UOM: <u> EA </u>	Unit Price: <input type="text" value="\$1,000.00"/>	Total: <input type="text" value="\$1,000.00"/>
3 1	Drop Manhole, 6-foot diameter, 0-Foot to 6.0-Foot Depth	Quantity: <u>  1 </u> UOM: <u> EA </u>	Unit Price: <input type="text" value="\$10,000.00"/>	Total: <input type="text" value="\$10,000.00"/>
3 2	Manhole Vertical Foot (VF), 6-Foot Diameter (Drop)	Quantity: <u>  5 </u> UOM: <u> VF </u>	Price: <input type="text" value="\$400.00"/>	Total: <input type="text" value="\$2,000.00"/>
3 3	Manhole Accessories for Location Within 100-Year Flood Plain	Quantity: <u> 22 </u> UOM: <u> EA </u>	Unit Price: <input type="text" value="\$300.00"/>	Total: <input type="text" value="\$6,600.00"/>
3 4	Reconnect Existing 8-Inch Gravity Sewer to New Manhole	Quantity: <u>  7 </u> UOM: <u> EA </u>	Unit Price: <input type="text" value="\$500.00"/>	Total: <input type="text" value="\$3,500.00"/>
3 5	Reconnect Existing 12-Inch Gravity Sewer to New Manhole	Quantity: <u>  1 </u> UOM: <u> EA </u>	Unit Price: <input type="text" value="\$900.00"/>	Total: <input type="text" value="\$900.00"/>
3 6	Reconnect Existing 18-Inch Gravity Sewer to New Manhole	Quantity: <u>  3 </u> UOM: <u> EA </u>	Unit Price: <input type="text" value="\$2,000.00"/>	Total: <input type="text" value="\$6,000.00"/>
3 7	Reconnect Existing 21-Inch Gravity Sewer to New Manhole	Quantity: <u>  1 </u> UOM: <u> EA </u>	Unit Price: <input type="text" value="\$4,000.00"/>	Total: <input type="text" value="\$4,000.00"/>
3 8	Pipe Abandonment, Safeload, 18-Inch Pipe	Quantity: <u> 280 </u> UOM: <u> LF </u>	Price: <input type="text" value="\$50.00"/>	Total: <input type="text" value="\$14,000.00"/>

39	Pipe Abandonment, Plug 8-Inch	Quantity: <u>8</u> UOM: <u>EA</u>	Unit Price: <input type="text" value="\$400.00"/>	Total: <input type="text" value="\$3,200.00"/>
40	Pipe Abandonment, Plug 18-Inch	Quantity: <u>5</u> UOM: <u>EA</u>	Unit Price: <input type="text" value="\$800.00"/>	Total: <input type="text" value="\$4,000.00"/>
41	Video Inspection of New Sewer Pipe	Quantity: <u>3627</u> UOM: <u>LF</u>	Price: <input type="text" value="\$3.00"/>	Total: <input type="text" value="\$10,881.00"/>
42	Tree Removal on 1840 Pershing Road and 520 Southbend Drive	Quantity: <u>3</u> UOM: <u>EA</u>	Unit Price: <input type="text" value="\$3,000.00"/>	Total: <input type="text" value="\$9,000.00"/>
43	Bituminous Concrete: Trench Construction, Street	Quantity: <u>641</u> UOM: <u>SY</u>	Price: <input type="text" value="\$90.00"/>	Total: <input type="text" value="\$57,690.00"/>
44	Bituminous Concrete: Private Parking Lots / Driveways	Quantity: <u>757</u> UOM: <u>SY</u>	Price: <input type="text" value="\$85.00"/>	Total: <input type="text" value="\$64,345.00"/>
45	Portland Cement Concrete Paving: Private Parking Lots / Driveways / Aprons	Quantity: <u>45</u> UOM: <u>SY</u>	Price: <input type="text" value="\$200.00"/>	Total: <input type="text" value="\$9,000.00"/>
46	Storm Sewer Removal and Replacement, 12-Inch	Quantity: <u>80</u> UOM: <u>LF</u>	Price: <input type="text" value="\$80.00"/>	Total: <input type="text" value="\$6,400.00"/>
47	Site Restoration, Method A	Quantity: <u>100</u> UOM: <u>SY</u>	Price: <input type="text" value="\$10.00"/>	Total: <input type="text" value="\$1,000.00"/>
48	Site Restoration, Method B	Quantity: <u>10000</u> UOM: <u>SY</u>	Price: <input type="text" value="\$2.00"/>	Total: <input type="text" value="\$20,000.00"/>
49	Site Restoration, Method C	Quantity: <u>100</u> UOM: <u>SY</u>	Price: <input type="text" value="\$4.00"/>	Total: <input type="text" value="\$400.00"/>
50	Seeding, Temporary, Extra as Directed by Engineer	Quantity: <u>1</u> UOM: <u>SY</u>	Price: <input type="text" value="\$4.00"/>	Total: <input type="text" value="\$4.00"/>
51	Concrete Curb Removal and Replacement	Quantity: <u>1290</u> UOM: <u>LF</u>	Price: <input type="text" value="\$44.00"/>	Total: <input type="text" value="\$56,760.00"/>
52	Dense Graded Aggregate - DGA, Extra as Directed by Engineer	Quantity: <u>1</u> UOM: <u>TN</u>	Price: <input type="text" value="\$30.00"/>	Total: <input type="text" value="\$30.00"/>
53	No. 9 Crushed Stone, Extra as Directed by Engineer	Quantity: <u>1</u> UOM: <u>TN</u>	Price: <input type="text" value="\$30.00"/>	Total: <input type="text" value="\$30.00"/>
54	No. 57 Crushed Stone, Extra as Directed by Engineer	Quantity: <u>1089</u> UOM: <u>TN</u>	Price: <input type="text" value="\$20.00"/>	Total: <input type="text" value="\$21,780.00"/>

55	No. 2 Crushed Stone, Extra as Directed by Engineer Quantity: <u>  1  </u> UOM: <u>  TN  </u> Price: <input type="text" value="\$30.00"/> Total: <input type="text" value="\$30.00"/>
56	Flowable (Controlled Density) Fill Quantity: <u>  1  </u> UOM: <u>  CY  </u> Price: <input type="text" value="\$150.00"/> Total: <input type="text" value="\$150.00"/>
57	Concrete Sidewalk Quantity: <u> 162 </u> UOM: <u>  SY  </u> Price: <input type="text" value="\$90.00"/> Total: <input type="text" value="\$14,580.00"/>
58	Chain Link Fence Quantity: <u> 320 </u> UOM: <u>  LF  </u> Price: <input type="text" value="\$50.00"/> Total: <input type="text" value="\$16,000.00"/>
59	Bypass Pumping and Setup Quantity: <u>  1  </u> UOM: <u>  LS  </u> Price: <input type="text" value="\$50,000.00"/> Total: <input type="text" value="\$50,000.00"/>
60	Maintenance of Traffic Quantity: <u>  1  </u> UOM: <u>  LS  </u> Price: <input type="text" value="\$30,000.00"/> Total: <input type="text" value="\$30,000.00"/>
61	Creek Crossing and Bank Restoration, Pipe Segment P-12 Quantity: <u>  1  </u> UOM: <u>  LS  </u> Price: <input type="text" value="\$7,000.00"/> Total: <input type="text" value="\$7,000.00"/>
62	Concrete Storm Channel Reconstruction Quantity: <u>  1  </u> UOM: <u>  LS  </u> Price: <input type="text" value="\$7,000.00"/> Total: <input type="text" value="\$7,000.00"/>
63	"Easement and Property Requirements (MOU Conditions)" Quantity: <u>  1  </u> UOM: <u>  LS  </u> Price: <input type="text" value="\$51,000.00"/> Total: <input type="text" value="\$51,000.00"/>
64	Allowance: Miscellaneous Site Improvements Quantity: <u>  1  </u> UOM: <u>  LS  </u> Price: <input type="text" value="\$500,000.00"/> Total: <input type="text" value="\$500,000.00"/>
65	Allowance: Third Party Professional Pre- Construction Photographic Documentation Quantity: <u>  1  </u> UOM: <u>  LS  </u> Price: <input type="text" value="\$3,500.00"/> Total: <input type="text" value="\$3,500.00"/>
66	Allowance: Culvert Monitoring Quantity: <u>  1  </u> UOM: <u> Lump Sum </u> Price: <input type="text" value="\$45,000.00"/> Total: <input type="text" value="\$45,000.00"/>
67	Allowance: MOU Condition 3 for 1908 Harrodsburg Road Quantity: <u>  1  </u> UOM: <u> Lump Sum </u> Price: <input type="text" value="\$10,000.00"/> Total: <input type="text" value="\$10,000.00"/>
68	<b>Package Header</b> Additive Alternate 1 - Award will be determined by base bid only <i>(Line excluded from response total)</i> Quantity: <u>  1  </u> UOM: <u> Lump Sum </u> Total: <input type="text" value="\$75,204.00"/>

## Package Items

### 68.1 Cut and Cap Existing 4-Inch Lateral Lines, Remove Line Exposed in Creek

Quantity:   4   UOM:  Each  Unit Price:  Total:

### 68.2 8-Inch Gravity Sewer Pipe, <6-Foot Depth, PVC

Quantity:  189  UOM:  Linear Feet  Price:  Total:

### 68.3 Standard Manhole, 4-Foot Diameter, 0-Foot to 6.0-Foot Depth

Quantity:   1   UOM:  Each  Unit Price:  Total:

### 68.4 Manhole Vertical Foot (VF), 4-Foot Diameter (Standard)

Quantity:   1   UOM:  VF  Price:  Total:

### 68.5 Chain Link Fence

Quantity:   40  UOM:  Linear Feet  Price:  Total:

### 68.6 Site Restoration, Method B (Straw and Seed)

Quantity:  906  UOM:  Square Yard  Price:  Total:

### 68.7 Tree Protection

Quantity:  125  UOM:  Linear Feet  Price:  Total:

### 68.8 PVC (SDR) 35 Gravity Sewer Lateral (Not in Pavement)

Quantity:   3   UOM:  Each  Unit Price:  Total:

### 68.9 Install Cleanout

Quantity:   3   UOM:  Each  Unit Price:  Total:

### 68.10 "Tee Fittings for Gravity Sewer Lateral Connection (Non-Ductile Iron or Insert Tee)"

Quantity:   3   UOM:  Each  Unit Price:  Total:

### 68.11 Manhole Accessories for Location Within 100-Year Flood Plain

Quantity:   1   UOM:  Each  Unit Price:  Total:

### 68.12 Storm Sewer Removal and Replacement, 12-Inch

Quantity:   20  UOM:  Linear Feet  Price:  Total:

### 68.13 Erosion and Sediment Control and Conformance With SWPP

Quantity:   1   UOM:  Lump Sum  Price:  Total:

**68.14** Clearing and Grubbing

Quantity:   1   UOM: Lump Sum Price:  Total:

**68.15** Video Inspection of New Sewer Pipe

Quantity:  189  UOM: Linear Feet Price:  Total:

**Response Total: \$4,919,523.00**





**ADDENDUM No. 1**

Bid Number: **#49-2023**

Date: May 16, 2023

Subject: Wolf Run Trunk Sewer Line F Sewer  
Wastewater System Improvements  
Remedial Measures Plan ID No. WR-06

Address inquiries to:  
Q&A Module on Ion Wave

Brian Marcum  
[brianm@lexingtonky.gov](mailto:brianm@lexingtonky.gov)  
(859) 258-3325

**TO ALL PROSPECTIVE SUBMITTERS:**

Please be advised of the following clarifications to the above referenced Bid:

	<b>Questions</b>	<b>Answers</b>
1.	None at this time.	
2.		
3.		

**1. CLARIFICATIONS**

A. None at this time.

**2. DRAWINGS**

A. None at this time.

**3. SPECIFICATIONS**

A. Section 00100 - Advertisement for Bids

Replace Paragraph 1.12 with the following:

A mandatory pre-Bid meeting will be held **10:00 am local time, Wednesday, May 24, 2023**, and will be a hybrid meeting. The in-person meeting will be held at the LFUCG DWQ building in the upstairs conference room at Lisle Industrial Avenue and via MS Teams. The Teams meeting information is below:





[https://teams.microsoft.com/l/meetup-join/19%3ameeting\\_MzkOWJiYtAtMmQ0YS00YjA0LTIIMTctMDZkZDE3NTIiZWRI%40thread.v2/0?context=%7b%22Tid%22%3a%22083fc4d2-72ad-412b-ae7d-6b81b83916dd%22%2c%22Oid%22%3a%22ef96af3a-f78e-4c94-8012-5e898c4cdb98%22%7d](https://teams.microsoft.com/l/meetup-join/19%3ameeting_MzkOWJiYtAtMmQ0YS00YjA0LTIIMTctMDZkZDE3NTIiZWRI%40thread.v2/0?context=%7b%22Tid%22%3a%22083fc4d2-72ad-412b-ae7d-6b81b83916dd%22%2c%22Oid%22%3a%22ef96af3a-f78e-4c94-8012-5e898c4cdb98%22%7d)

Meeting ID: 213 587 137 33

Passcode: V6egSo

**Or call in (audio only)**

1 502-208-2565

Phone Conference ID: 182 492 966#

Todd Slatin, Director  
Division of Central Purchasing

All other terms and conditions of the Bid and specifications are unchanged.  
This letter should be signed, attached to and become a part of your Bid.

COMPANY NAME: Tribute Contracting & Consultants, LLC

ADDRESS: 2125 County Rd 1, South Point, OH 45680

SIGNATURE OF BIDDER:



**ADDENDUM No. 2**Bid Number: **#49-2023**

Date: May 23, 2023

Subject: Wolf Run Trunk Sewer Line F Sewer  
Wastewater System Improvements  
Remedial Measures Plan ID No. WR-06Address inquiries to:  
Q&A Module on Ion WaveBrian Marcum  
[brianm@lexingtonky.gov](mailto:brianm@lexingtonky.gov)  
(859) 258-3325**TO ALL PROSPECTIVE SUBMITTERS:**

Please be advised of the following clarifications to the above referenced Bid:

	<b>Questions</b>	<b>Answers</b>
1.	Do any of the Bore & Jack segments require continuous 24 hours per day, 7 days a week operation to install casing pipe?	No
2.	Will conshield be required for any of the proposed manholes?	No
3.	Do the items MOU Conditions listed on plan sheet C-06 have bid items associated to them or is the work incidental? For example, how will the temporary 4' tall chain link fence be paid for at 626 Blue Ash Drive?	Bid Item 63 - Easement and Property Requirements (MOU Conditions) is a Lump Sum item that should be priced to contain all the work associated with meeting MOU Conditions found on page C-06.
4.	Is the project, in whole or part, for the construction of sewer or water infrastructure that services the general public and is being fulfilled on behalf of an organization that meets the standards of KRS 139.480(34) as amended by HB360?	Yes





5.	Can flows be provided for the existing sanitary lines that will require bypass pumping?	Flows along the existing trunk are as follows:		
			<b>Peak Dry Weather Flow-Firm Capacity (MGD)</b>	<b>Peak Wet Weather Flow-Firm Capacity (MGD)</b>
		<b>Sewer Segment</b>		
		Wolf Run Line F	0.999	3.668

## 1. CLARIFICATIONS

- A. None at this time.

## 2. DRAWINGS

- A. Sheet C-06 PROPERTY OWNER INFORMATION AND MOU CONDITIONS,

ADD the following MOU Conditions under 1927 HARRODSBURG ROAD

1. As the work on the property has a significant impact on the operation of the Tenant's business, the contractor shall make every effort to minimize the time required to occupy the property. Once work commences, the contractor shall diligently and continuously pursue to completion the construction required on the property, including paving. Long term staging of equipment and/or materials is not allowed.
2. The contractor shall maintain access to the drive through and the Harrodsburg Rd. entrances, at all times.
3. Any areas of the parking lot, outside the easement, that are damaged by the contractor or their sub-contractor(s) shall be repaired/repaved at the contractor's expense.
4. The contractor shall give LFUCG 45 days notice before any work on or mobilization onto the property.

- B. Sheet C-06 PROPERTY OWNER INFORMATION AND MOU CONDITIONS,

ADD the attached Figures A.1, A.2, and A.3 for 740 Spring Meadows Drive.

- C. Sheet C-06 PROPERTY OWNER INFORMATION AND MOU CONDITIONS,

ADD the attached Figure A.1 for 1945 Harrodsburg Road.



MAYOR LINDA GORTON



**LEXINGTON**

TODD SLATIN  
DIRECTOR  
CENTRAL PURCHASING

**3. SPECIFICATIONS**

A. None at this time.

Todd Slatin, Director  
Division of Central Purchasing

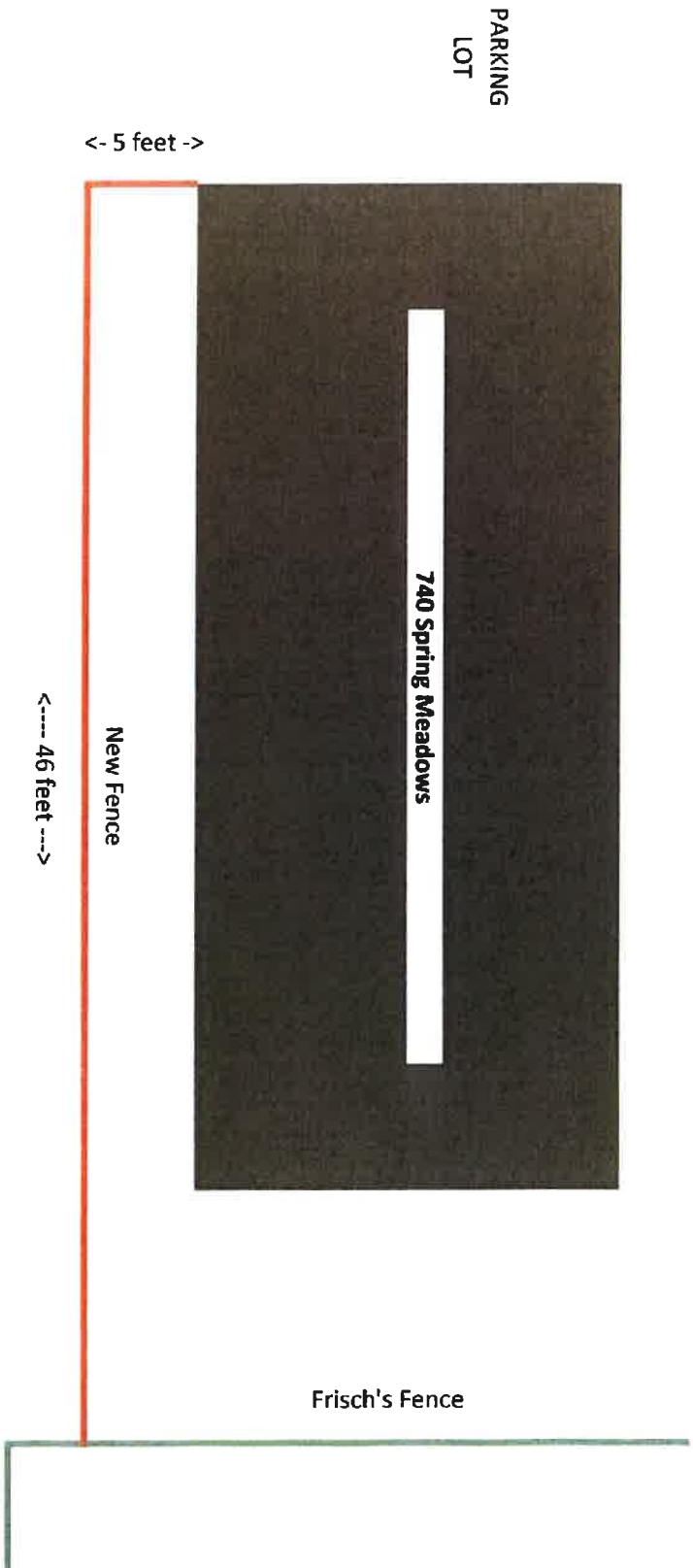
All other terms and conditions of the Bid and specifications are unchanged.  
This letter should be signed, attached to and become a part of your Bid.

COMPANY NAME: Tribute Contracting & Consultants, LLC

ADDRESS: 2125 County Rd 1, South Point, OH 45680

SIGNATURE OF BIDDER:





4 by 4 treated posts, 6 foot on center
Gate width - 36 inches
Rear corner of fence to be placed to preserve existing large diameter trees

Property Owner Endorsement



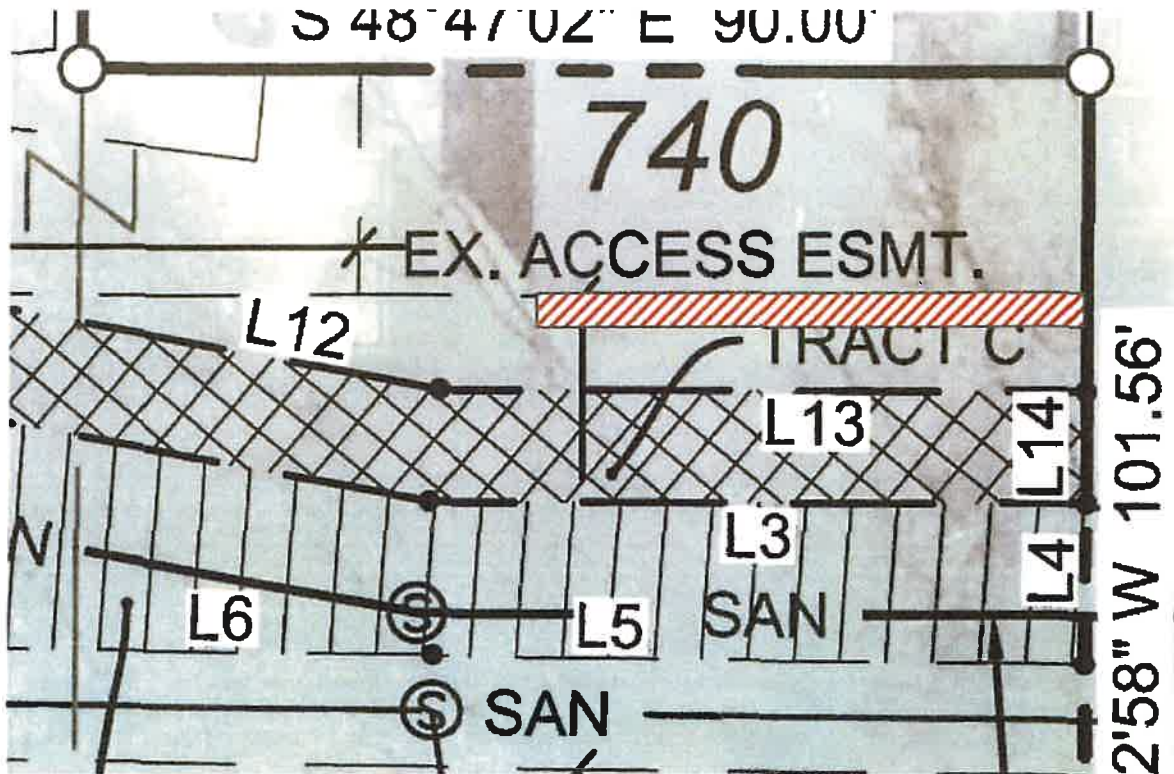
Example - illustration only



Figure A.2

740 Spring Meadows

Post Construction Privacy Fence



1. Highlighted area shows limits of the new, two-sided fence that will be constructed once the pipeline work is complete.
2. Fence will be 6 feet high and extend from the front corner of 740 Spring Meadows. The fence will be off-set from the exterior wall no more than 5 feet. A 36-inch wide gate will be installed on the fence facing the parking lot. The fence will extend to the rear of the parcel and terminate with the existing rear fence creating a barrier preventing easy access to the rear of the parcel from the creek area.
3. The fence will be constructed with the blanks facing outward and have an appearance similar to that shown on [Figure A](#).
4. LFUCG's contractor is responsible for all permits and workmanship involving the fence, the property owner is responsible for restoring areas inside the finished fence.
5. The contractor is instructed to construct the gate and fence in a manner consistent the specification titled [Section 32 31 14 Wood Fences & Gates](#). In the case where local codes conflict with the specifications, local codes prevail.
6. Once installation and verified as functional, the fence and associated hardware become the property owner's sole responsibility.

**SECTION 32 31 15**

**WOOD FENCES & GATES**  
Last Updated: November 18, 2015

**Part 1 GENERAL**

**1.1 SECTION INCLUDES**

- A. Requirements regarding wood fencing and gates on DISTRICT lands or interest in lands.

**1.2 SUBMITTALS**

- A. Drawings: Indicate plan layout, grid, size and spacing of components, accessories, fittings, anchorage, and post section.
- B. Data: Submit manufacturer's installation instructions and procedures, including details of fence and gate installation.

**Part 2 PRODUCTS**

**2.1 GENERAL**

- A. All wood materials shall be treated wood, or wood of a natural resistance to decay. Materials shall be free from loose knots, cracks, and other imperfections.
- B. Cast-in-place Concrete: Class 3000 minimum, Section 03 30 04.

**2.2 WOOD BOARDS OR SLATS**

- A. Wood boards or slats shall be of cedar, redwood, combed spruce or similar wood acceptable to DISTRICT.
- B. Wood boards or slats shall be between 3/8 inches and 5/8 inches thick and be no greater than 6 inches wide.

**2.3 POSTS**

- A. Fence and Man Gate posts shall be 4-inch by 4-inch.
- B. Truck Gate posts shall be at minimum dual 6-inch by 6-inch or as recommended by manufacturer.
- C. Posts shall be pressure treated redwood, douglas fir-larch, cedar or similar wood acceptable to DISTRICT.
- D. Buried post ends should be treated with an approved wood preservative product.

**2.4 GATES**

- A. Provide additional horizontal, vertical, and diagonal members to ensure proper gate operation and for attachment of wood, hardware and accessories. Consult manufacturer as necessary.
- B. Accessibility: Gate stops, latches and locks shall be accessible from either side of gate.
- C. Types: Man Gates and Truck Gates



1. Man Gates
  - a. Openings shall be a minimum of 3 feet wide.
2. Truck Gates
  - a. Openings shall be a minimum of 12 feet wide.
- D. Gate designs shall be approved by DISTRICT prior to installation.

## 2.5 GATE HARDWARE

- A. Gate hardware including, but not limited to, latches, hinges, stops and bolts shall be stainless steel, powder coated black, or galvanized.
- B. Hinges and Pins shall be heavy duty and sized as per manufacturer's recommendations.
- C. For truck gates (double-leaf), a drop rod or stop shall be installed on one leaf, include at least one guide and shall extend into concrete base or similarly solid base.
- D. Dual access (accessible and lockable from either side) latch and lock systems are required on all gates.
  1. The following dual access latch and lock systems are allowed and must be approved in writing by the District prior to installation:
    - a. Lock Thru™ Latch (website: <http://www.hooverfence.com/woodfence/lockthru.htm>);
    - b. Sure Latch (website: <http://surelatch.com/gate-latches/7-lockable-two-way-latch-and-pin.html>);
    - c. or Equal.

## Part 3 EXECUTION

### 3.1 PREPARATION.

- A. Follow all applicable blue stakes procedures.
- B. Unless otherwise directed, DISTRICT or DISTRICT's representative shall be on-site during entire fence installation.

### 3.2 LAYOUT OF WORK

- A. Under no circumstance shall a fence or gate post be located above the Salt Lake Aqueduct or Point of the Mountain Aqueduct.
- B. Gate location shall be approved by District prior to installation.

### 3.3 INSTALLATION OF POSTS

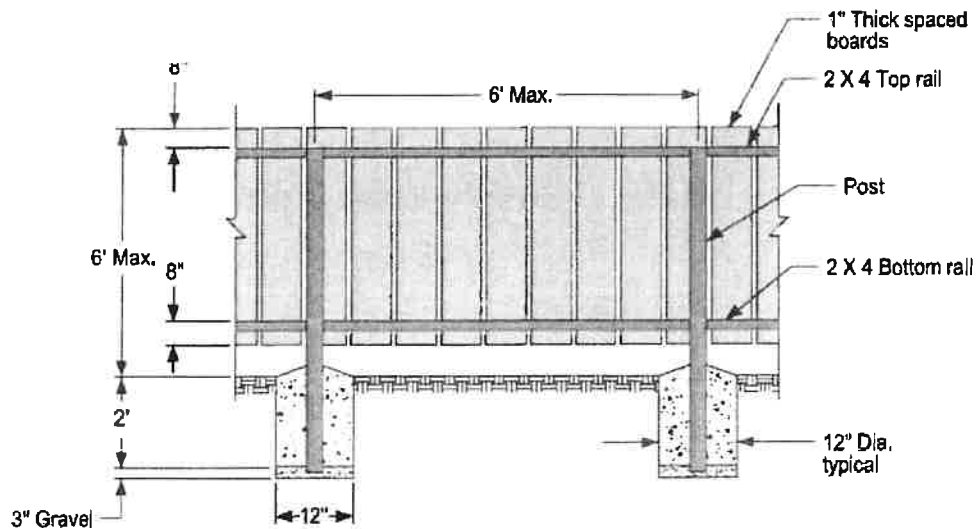
- A. Posts shall be set true to line and grade.
- B. Set posts in 12-inch diameter concrete footings extending at least 24-inches into undisturbed natural ground or properly compacted fill.

### 3.4 INSTALLATION OF FENCE

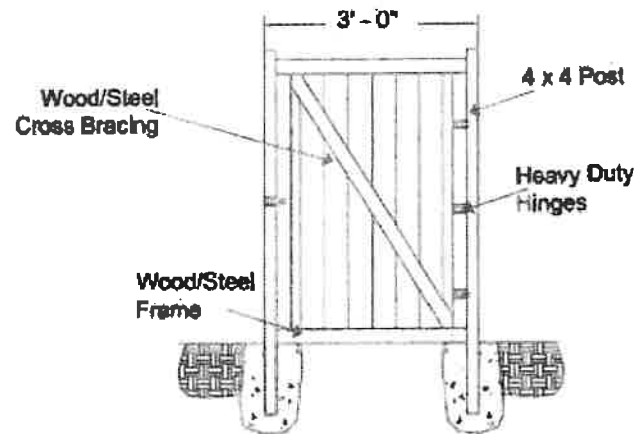
- A. Typical fence installation can be found in Figure 1 at the end of this specification section.

### 3.5 INSTALLATION OF GATES

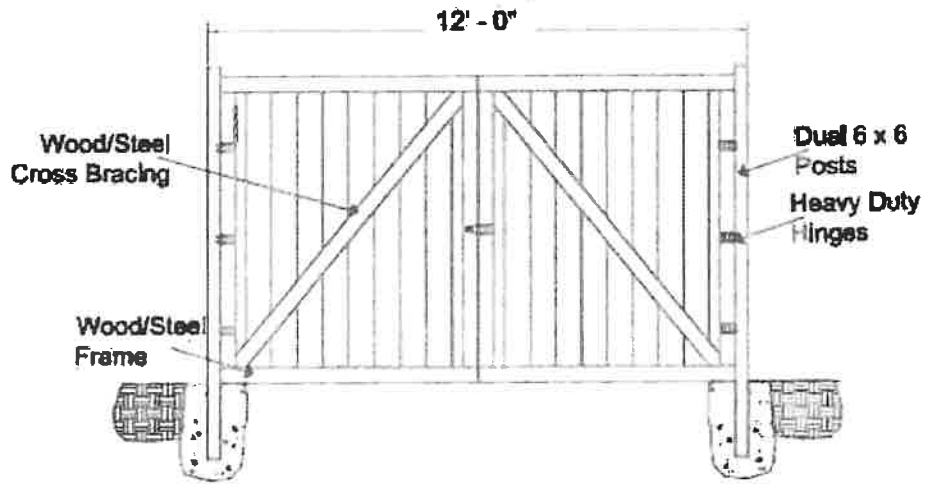
- A. Install gates plumb, level, and secure for full opening without interference. Install ground-set items in concrete for anchorage as recommended by the fence manufacturer. Adjust hardware for smooth operation.
- B. Man Gates:
1. Shall be installed on all enclosed or fenced-in right of way (Fee or Easement) areas at Applicant's expense.
  2. Shall be configured to allow District staff to enter or exit the enclosed area.
  3. Once gate is installed coordinate with District on lock installation.
  4. Typical gate installation can be found in Figure 2 at the end of this specification section..
- C. Truck Gates:
1. Shall be installed at the request of the District and shall be at no additional cost to the District
  2. Shall open/close in direction as directed by District.
  3. Shall be configured to allow District vehicles to enter the enclosed area to perform inspections, work, etc... and exit to the opposite side of the enclosed area, if necessary.
  4. Once gate is installed coordinate with District on lock installation
  5. Typical gate installation can be found in Figure 3 at the end of this specification section.



**FIGURE 1 Wood Fence Detail**

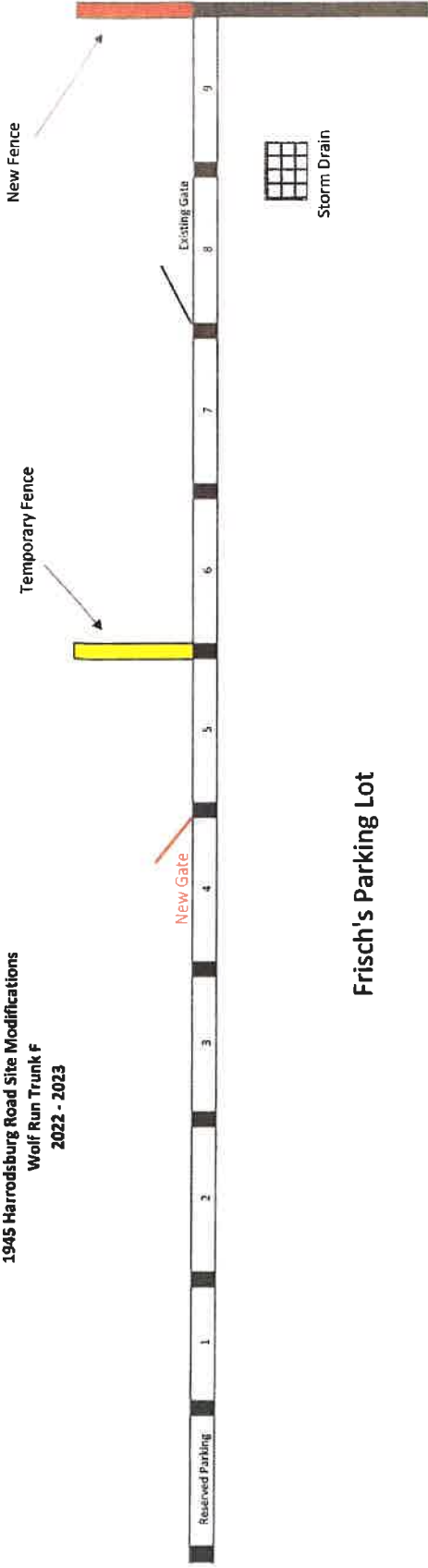


**FIGURE 2 - Wood Man Gate Detail**



**FIGURE 3 Wood Truck Gate Detail**

1945 Harrodsburg Road Site Modifications  
Wolf Run Trunk F  
2022 - 2023



Frisch's Parking Lot

SEQUENCE OF WORK

- 1 Fall 2022 - Install a new gate in the 4th panel right of Frisch's drive thru reserved parking spots. Gate should be placed on right side of panel 4.
- 2 Fall 2022 - Install one panel of privacy fence as shown between panels 5 and 6. Purpose of this temporary fence is to isolate construction area from other part of parcel.
- 3 Post pipeline construction - restore existing privacy fence and install one new panel of privacy fence perpendicular to the corner post. Purpose of this fence panel is to provide a longer term means to isolate the parcel from the adjoining parcels.



**ADDENDUM No. 3**

Bid Number: **#49-2023**

Date: June 6, 2023

Subject: Wolf Run Trunk Sewer Line F Sewer  
Wastewater System Improvements  
Remedial Measures Plan ID No. WR-06

Address inquiries to:  
Q&A Module on Ion Wave

Brian Marcum  
[brianm@lexingtonky.gov](mailto:brianm@lexingtonky.gov)  
(859) 258-3325

**TO ALL PROSPECTIVE SUBMITTERS:**

Please be advised of the following clarifications to the above referenced Bid:

	<b>Questions</b>	<b>Answers</b>
1.	Will the Owner consider Fiberstrong™ FRPM pipe as manufactured by Future Pipe Industries (FPI) as an equal pipe for use on the project?	No. At this time there is not sufficient information for the design team to come to a conclusion about whether this pipe is equal to other FRP pipe specified.
2.	Will the contractor be able to utilize the drive between the creek and 1908 Harrodsburg Road?	No. The property owner (and tenants) need to have access to the basement doors from the south entrance of the driveway. Therefore, the contractor will need to keep this area accessible.
3.	The soils report shows mixed soil conditions for some of the bores. Can the new easements be utilized for additional soil exploration?	Soil investigations on LFUCG owned properties are allowable. All other soil explorations will need to be preapproved with property owners. LFUCG can help get contractors in contact with property owners.
4.	If alternate is not accepted, what would the construction look like for the laterals exposed in the creek?	The laterals will remain exposed in the creek and be reconnected into the new trunk line at their current location.





5.	Per Addendum #2, question #4, the answer being yes. Is all the permanent material required for the project tax exempt or just the sanitary sewer lines and pipe material?	Yes, all permanent material is tax exempt in accordance with KRS 139.480(34). Any material that will remain in place after the Contractor demobilizes is tax exempt. Temporary items are not tax exempt.
----	---	--

**1. CLARIFICATIONS**

- A. Please see the attached prebid meeting minutes.

**2. DRAWINGS**

- A. None at this time.

**3. SPECIFICATIONS**

- A. Specification Section 00410 BID FORM, BID SCHEDULE, ADD Bid Item 66 and 67  
ADD

- 66. Allowance: Culvert Monitoring 1 LS \$45,000
- 67. Allowance: MOU Condition 3 for 1908 Harrodsburg Road 1 LS \$10,000

- B. Specification Section 00410 BID FORM, BID SCHEDULE,  
CHANGE line of Bid Schedule from 'TOTAL BASE BID (Items 1 thru 65)' to 'TOTAL BASE  
BID (Items 1 thru 67).

- C. Specification Section 01025 MEASUREMENT AND PAYMENT, PART 2- PRODUCTS,  
ADD two new paragraphs after 2.49,  
ADD

**2.50 ALLOWANCE: CULVERT MONITORING**

- A. An allowance has been established for culvert monitoring of the private culvert located at 1946 Harrodsburg Road. Contractor shall contract with a third party licensed professional engineer, Appalachian Mining & Engineering, Inc. or equal, to provide and execute a plan for monitoring deformation of the existing private culvert to within 1/1000th





of an inch while work is occurring to bore tunnel P-10 from STA 26+30 to STA 27+40. Vibration will also be monitored in inches/sec. The monitoring plan shall be submitted under the requirements of a submittal according to Section 01300. The plan shall include proposed shoring to be onsite should a movement alarm occur during monitoring.

Prior to monitoring, an inspection of the private culvert is to be conducted to establish the baseline condition and dimensions of the culvert from which to compare future observations. Since destructive or invasive testing cannot be conducted on the private culvert, the physical condition, dimensions, and observations in the culvert will be used to develop a displacement threshold and/or alarm trigger for the monitoring system. This will establish the pre-construction condition of the private culvert. This pre-construction condition survey shall include photographs.

Monitoring of the culvert will be conducted and reviewed on a defined schedule. As the sewer line bore approaches the overlying private culvert, monitoring of the culvert will be conducted on site and in real time to monitor deformation and vibration as the proposed sewer line is bored beneath the existing private box culvert. The deformation and vibration measurements will be recorded at appropriate intervals on a datalogger. The datalogger will provide either a visual and/or auditory alarm(s) if movement greater than the defined threshold for displacement is observed. The footage location of the tunneling cutter head defined as 000+00 will be noted for each measurement. The data output shall be saved and provided to Owner and Project Engineer during and after the sewer pipe driveage is complete. A post-construction survey of the culvert including photographs shall be conducted once the annular space between the bore and casing pipe has been grouted full and it has cured.

Costs shall include engineering, materials, monitoring, reporting, installation, and removal of equipment as needed to accomplish the work.

**2.51 ALLOWANCE: MOU CONDITION 3 FOR 1908 HARRODSBURG ROAD**

A. An allowance has been established to cover the work described in MOU Condition number 3 for 1908 Harrodsburg Road. The Condition reads: 'A pre-construction survey of the building by a third-party structural engineer, meeting with the property Owner's approval, shall be performed prior to any excavation work on the property. A post-construction survey shall be conducted upon completion of the work to determine if there have been any changes to the structure. The Engineer of Record (EOR) shall be responsible for coordination of the inspections.' Costs shall include the cost for the third-party engineer to complete work.

- D. Specification Section 01210 ALLOWANCES, PART 1 - GENERAL, 1.01 SCOPE OF WORK, C, ADD two new paragraphs after paragraph 2.  
ADD





3. Culvert Monitoring (undefined allowance) - \$45,000 has been established for providing culvert monitoring of the private culvert located at 1946 Harrodsburg Road. Contractor shall contract with a third party licensed professional engineer, Appalachian Mining & Engineering, Inc. or equal, to provide and execute a plan for monitoring deformation of the existing private culvert to within 1/1000th of an inch while work is occurring to bore tunnel P-10 from STA 26+30 to STA 27+40. Vibration will also be monitored in inches/sec. The monitoring plan shall be submitted under the requirements of a submittal according to Section 01300. The plan shall include proposed shoring to be onsite should a movement alarm occur during monitoring.

Prior to monitoring, an inspection of the private culvert is to be conducted to establish the baseline condition and dimensions of the culvert from which to compare future observations. Since destructive or invasive testing cannot be conducted on the private culvert, the physical condition, dimensions, and observations in the culvert will be used to develop a displacement threshold and/or alarm trigger for the monitoring system. This will establish the pre-construction condition of the private culvert. This pre-construction condition survey shall include photographs.

Monitoring of the culvert will be conducted and reviewed on a defined schedule. As the sewer line bore approaches the overlying private culvert, monitoring of the culvert will be conducted on site and in real time to monitor deformation and vibration as the proposed sewer line is bored beneath the existing private box culvert. The deformation and vibration measurements will be recorded at appropriate intervals on a datalogger. The datalogger will provide either a visual and/or auditory alarm(s) if movement greater than the defined threshold for displacement is observed. The footage location of the tunneling cutter head defined as 000+00 will be noted for each measurement. The data output shall be saved and provided to Owner and Project Engineer during and after the sewer pipe driveage is complete. A post-construction survey of the culvert including photographs shall be conducted once the annular space between the bore and casing pipe has been grouted full and it has cured.

Costs shall include engineering, materials, monitoring, reporting, installation, and removal of equipment as needed to accomplish the work.

4. MOU Condition 3 for 1908 Harrodsburg Road - \$10,000 has been established to cover the work described in MOU Condition number 3 for 1908 Harrodsburg Road. The Condition reads: 'A pre-construction survey of the building by a third-party structural engineer, meeting with the property Owner's approval, shall be performed prior to any excavation work on the property. A post-construction survey shall be conducted upon completion of the work to determine if there have been any changes to the structure. The Engineer of Record (EOR) shall be responsible for coordination of the inspections.' Costs shall include the cost for the third-party engineer to complete work.





MAYOR LINDA GORTON



**LEXINGTON**

TODD SLATIN  
DIRECTOR  
CENTRAL PURCHASING

A handwritten signature in blue ink that reads "Todd Slatin".

Todd Slatin, Director  
Division of Central Purchasing

All other terms and conditions of the Bid and specifications are unchanged.  
This letter should be signed, attached to and become a part of your Bid.

COMPANY NAME: Tribute Contracting & Consultants, LLC

ADDRESS: 2125 County Rd 1, South Point, OH 45680

SIGNATURE OF BIDDER: 



SECTION 00410

BID FORM

WOLF RUN TRUNK SEWER LINE F WASTEWATER SYSTEM IMPROVEMENTS

Division of Water Quality  
Lexington-Fayette Urban County Government

LFUCG Bid No. 49-2023

1.01 GENERAL

Place: Lexington, Kentucky

Date: June 13, 2023

The following Bid Form shall be followed exactly in submitting a Bid for this Work.

This Bid Form Submitted by Tribute Contracting & Consultants, LLC  
2125 County Rd 1, South Point, OH 45680  
(Name and Address of Bidder)

(Hereinafter called "Bidder"), organized and existing under the laws of the State of Ohio,

doing business as a corporation  
"a corporation," "a partnership," or an "individual" as applicable

To: Lexington-Fayette Urban County Government  
(Hereinafter called "Owner")  
Office of the Director of Central Purchasing  
200 East Main Street, Room 338  
Lexington, KY 40507

The Bidder, in compliance with your Advertisement for Bids for the **Wolf Run Trunk Sewer Line F Wastewater System Improvements**; Lexington, Kentucky, having examined the Contract Documents including the Plans and Specifications with related documents, having examined the site for proposed Work, and being familiar with all of the conditions and any and all addendums surrounding the construction of the proposed Project, including the availability of materials and labor, hereby proposes to furnish all labor, materials, and supplies, and to construct the Project in accordance with the Contract Documents, within the time set forth therein, and at the unit prices stated hereinafter. These prices are to cover all expenses incurred in performing the Work required under the Contract Documents, of which this Bid is a part.

The Bidder hereby agrees to commence Work under this Contract on a date to be specified in a written "Notice to Proceed" of the Owner and to substantially complete the Project within

365 days, consecutive calendar days. Bidder further agrees to pay liquidated damages, the sum of One Thousand Dollars and Zero Cents (\$1,000.00) for each consecutive day thereafter.

The Bidder hereby acknowledges receipt of the following addenda:

Addendum No. 1 Date 05-16-23 Addendum No. \_\_\_\_ Date \_\_\_\_\_

Addendum No. 2 Date 05-23-23 Addendum No. \_\_\_\_ Date \_\_\_\_\_

Addendum No. 3 Date 06-06-23 Addendum No. \_\_\_\_ Date \_\_\_\_\_

Addendum No. 4 Date 6-13-2023 Addendum No. \_\_\_\_ Date \_\_\_\_\_

Insert above the number and the date of any Addendum issued and received. If none has been issued and received, the word "NONE" should be inserted.

**1.02 LEGAL STATUS OF BIDDER**

Bidder Tribute Contracting & Consultants LLC

Date 06-13-23

A. \*A corporation duly organized and doing business under the laws of the State of Ohio, for whom Todd Harrah bearing the official title of manager/member whose signature is affixed to this Bid is duly authorized to execute contracts.

~~B. \*A Partnership, all of the members of which, with addresses are: (Designate general partners as such)~~

\_\_\_\_\_  
\_\_\_\_\_  
\_\_\_\_\_  
\_\_\_\_\_  
\_\_\_\_\_

~~C. \*An individual, whose signature is affixed to this Bid. (Print name)~~

\_\_\_\_\_  
\_\_\_\_\_

\* The Bidder shall fill out the appropriate form and strike out the other two.

**1.03 BIDDERS AFFIDAVIT**

Comes the Affiant, Todd Harrah, and after being first duly sworn, states under penalty of perjury as follows:

- A. His/her name is Todd Harrah and he/she is the individual submitting the Bid or is the authorized representative of Tribute Contracting & Consultants, LLC, the entity submitting the Bid (hereinafter referred to as "Bidder").
- B. Bidder will pay all taxes and fees, which are owed to the Lexington-Fayette Urban County Government at the time the Bid is submitted, prior to award of the Agreement and will maintain a "current" status in regard to those taxes and fees during the life of the Agreement.
- C. Bidder will obtain a Lexington-Fayette Urban County Government business license, if applicable, prior to award of the Agreement.
- D. Bidder has authorized the Division of Central Purchasing to verify the above-mentioned information with the Division of Revenue and to disclose to the Urban County Council that taxes and/or fees are delinquent or that a business license has not been obtained.
- E. Bidder has not knowingly violated any provision of the campaign finance laws of the Commonwealth of Kentucky within the past five (5) years and the award of an Agreement to the Bidder will not violate any provision of the campaign finance laws of the Commonwealth.
- F. Bidder has not knowingly violated any provision of Chapter 25 of the Lexington-Fayette Urban County Government Code of Ordinances, known as the "Ethics Act."
- G. Bidder acknowledges that "knowingly" for purposes of this Affidavit means, with respect to conduct or to circumstances described by a statute or ordinance defining an offense, that a person is aware or should have been aware that his/her conduct is of that nature or that the circumstance exists.

Further, Affiant sayeth naught.

Todd Harrah  
Affiant Signature

STATE OF Kentucky  
COUNTY OF Boyd

JOHN M PARSLEY  
NOTARY PUBLIC  
STATE AT LARGE - KENTUCKY  
COMMISSION # KYNP35081  
MY COMMISSION EXPIRES OCTOBER 02, 2025

The foregoing instrument was subscribed, sworn to and acknowledged before me by Todd Harrah on this the 13<sup>th</sup> day of June, 2023

John M. Parsley  
My commission expires: 10-02-25

NOTARY PUBLIC, STATE AT LARGE

#### 1.04 BID SCHEDULE

A. The Bidder agrees to perform all the Work described in the Specifications and shown on the Plans for the following proposed lump sum and/or unit prices, if applicable, which shall include the furnishing of all labor, materials, supplies, equipment and/or vehicle usage, services, all items of cost, overhead, taxes (federal, state, local), and profit for the Contractor and any Subcontractor involved, within the time set forth herein. If unit prices are applicable, Bidder must make the extensions and additions showing the total amount of Bid. In all cases of discrepancies or math errors the amount written in for the unit price of an item shall govern.

B. If a discrepancy between the unit price and the item total exists, the unit price prevails except:

If the unit price is illegible, omitted, or the same as the item total, item total prevails and the unit price is the quotient of the item total and the quantity.

C. If the unit price and the item total are illegible or are omitted, the bid may be determined nonresponsive. If a lump sum total price is illegible or is omitted, the bid may be determined nonresponsive.

By submitting a Bid, the Bidder acknowledges that the trenchless constructability of all tunnels shown on the Contract Drawings have been vetted by the Bidder and that the Bidder's own design has been advanced to the extent necessary to establish, in the Bidder's own opinion, the ability to safely construct by means of tunneling methods.

D. A Preliminary Tunnel Plan shall be developed by the Bidder, concurrent with the development of the Bid, to document the Bidder's awareness and understanding of the quantity of, location of, and access to the portions of the Contract that are required to be built by trenchless means. The Preliminary Tunnel Plan is a conceptual plan establishing the capability to accomplish the tunnel construction required by Contract. Following award of the Contract, the Contractor shall modify the Preliminary Tunnel Plan as needed to develop the most efficient construction plan of operation in accordance with Contract Documents. Requirements for submittal of and content of the Preliminary Tunnel Plan shall be in accordance with this Section.

E. Apparent Low Bidder shall submit, no later than 48 hours after Bid Opening, a Preliminary Tunnel Work Plan as part of its Bid. The Preliminary Tunnel Work Plan shall consist of sketches, markups, and/or narrative explanations. Legible hand written notes on Bid Documents (e.g.: Bid Drawings) are acceptable. The Preliminary Tunnel Work Plan shall include the following:

1. **Indication of diameter, type, and material of initial tunnel support, casings, or jacking pipe for Tunnels P-8, P-10, P-21, and P-27.**
2. Indication of tunnel drive direction.

3. Indication of basic tunnel equipment type, size, make, and model anticipated such as tunnel boring machine size, microtunnel boring machine, pipe jacked shield, auger boring machine, or utility hand tunneling methods.
4. Indication of conceptual understanding of all shaft locations, size (e.g.: diameter, length and width), orientation, anticipated conceptual method of support, staging/storage, and means of site access for each tunnel shaft as required for the Bidder's specific means and methods.
5. Conceptual markup of plan, profile, or detail drawings of the following:
  - a. groundwater removal process and safe discharge locations,
  - b. spoil handling and storage,
  - c. method of installation and blocking of carrier pipe, and
  - d. annular space grouting.
- F. Preliminary indication all areas where potential ground modification strategies are anticipated or will be further explored by the Bidder upon award of the Contract.
- G. For a lump sum based bid, the item total is the bid amount the Owner uses for bid comparison.
- H. For a unit price based bid, the sum of the item totals is the bid amount the Owner uses for bid comparison.
- I. The Bidder must indicate the base bid pipe material by circling the selected pipe material at the time of the submission of the Bid.
- J. The Owner's decision on the bid amount is final.



**BID SCHEDULE**

Item	Description	Qty	Unit	Unit Price	Item Price
1	Mobilization	1	LS	\$ 81,000.00	\$ 81,000.00
2	Bonds and Insurance	1	LS	\$ 83,000.00	\$ 83,000.00
3	General Requirements	1	LS	\$ 467,000.00	\$ 467,000.00
4	Demobilization	1	LS	\$ 8,000.00	\$ 8,000.00
5	Erosion and Sediment Control and Conformance with SWPPP	1	LS	\$ 24,000.00	\$ 24,000.00
6	Clearing and Grubbing	1	LS	\$ 75,000.00	\$ 75,000.00
7	Tree Protection	555	LF	\$ 3.00	\$ 1665.00
8	PVC (SDR) 35 Gravity Sewer Lateral (In Pavement)	9	EA	\$ 5,800.00	\$ 52,200.00
9	PVC (SDR) 35 Gravity Sewer Lateral (Not in Pavement)	13	EA	\$ 3,800.00	\$ 49,400.00
10	Install Cleanout	22	EA	\$ 850.00	\$ 18,700.00
11	Tee Fittings for Gravity Sewer Lateral Connection (Non-Ductile Iron or Inserta Tee)	22	EA	\$ 450.00	\$ 9,900.00
12	8-Inch Gravity Sewer Pipe, <6-Foot Depth, (DIP <u>PVC</u> )	259	LF	\$ 233.00	\$ 60,347.00
13	21-Inch Gravity Sewer Pipe, <6-Foot Depth (DIP <u>PVC</u> FRP)	388	LF	\$ 298.00	\$ 115,624.00
14	21-Inch Gravity Sewer Pipe, 6.1-Foot to 10.0-Foot Depth (DIP <u>PVC</u> FRP)	1,513	LF	\$ 333.00	\$ 503,829.00
15	21-Inch Gravity Sewer Pipe, 10.1-Foot to 15.0-Foot Depth (DIP <u>PVC</u> FRP)	489	LF	\$ 362.00	\$ 177,018.00
16	21-Inch Gravity Sewer Pipe, 15.1-Foot to 20.0-Foot Depth (DIP <u>PVC</u> FRP)	159	LF	\$ 440.00	\$ 69,960.00
17	21-Inch Gravity Sewer Pipe, > 20.1-Foot Depth (DIP <u>PVC</u> FRP)	12	LF	\$ 500.00	\$ 6,000.00
18	Tunnel Line Segment P-8, Harrodsburg Road, 331± Linear Feet of 36-Inch Minimum Casing Size With a 21-Inch Carrier Pipe. <u>Guided Bore and Jack (GB&amp;J)</u>	1	LS	\$ 690,000.00	\$ 690,000.00
19	Tunnel Line Segment P-10, Wolf Run Creek, 141± Linear Feet of 36-Inch Minimum Casing Size With a 21-Inch Carrier Pipe <u>Guided Bore and Jack (GB&amp;J)</u>	1	LS	\$ 323,000.00	\$ 323,000.00

20	Tunnel Line Segment P-21, Southbend Road, 63± Linear Feet of 36-Inch Minimum Casing Size With a 21-Inch Carrier Pipe. <u>Guided Bore and Jack (GB&amp;J)</u>	1	LS	\$	\$	190,000.00	190,000.00
21	Tunnel Line Segment P27, Lafayette Parkway, 331± Linear Feet of 36-Inch Minimum Casing Size With a 21-Inch Carrier Pipe. <u>Guided Bore and Jack (GB&amp;J)</u>	1	LS	\$	\$	652,000.00	652,000.00
22	Connection to Existing Sewer, 18-Inches	2	EA	\$	\$	5,000.00	10,000.00
23	Manhole Abandonment	9	EA	\$	\$	1,000.00	9,000.00
24	Standard Manhole, 4-Foot Diameter, 0-Foot to 6.0-Foot Depth	21	EA	\$	\$	5,400.00	113,400.00
25	Manhole Vertical Foot (VF), 4-Foot Diameter (Standard)	90	VF	\$	\$	220.00	19,800.00
26	Drop Manhole, 4-Foot Diameter, 0-Foot to 6.0-Foot Depth	5	EA	\$	\$	8,200.00	41,000.00
27	Manhole Vertical Foot (VF), 4-Foot Diameter (Drop)	27	VF	\$	\$	300.00	8,100.00
28	Drop Manhole, 5-Foot Diameter, 0-Foot to 6.0-Foot Depth	1	EA	\$	\$	9,000.00	9,000.00
29	Manhole Vertical Foot (VF), 5-Foot Diameter (Int. Drop)	16	VF	\$	\$	300.00	4,800.00
30	Internal Manhole Drop Connection, 8-Inch Diameter	1	EA	\$	\$	1,000.00	1,000.00
31	Drop Manhole, 6-foot diameter, 0-Foot to 6.0-Foot Depth	1	EA	\$	\$	10,000.00	10,000.00
32	Manhole Vertical Foot (VF), 6-Foot Diameter (Drop)	5	VF	\$	\$	400.00	2,000.00
33	Manhole Accessories for Location Within 100-Year Flood Plain	22	EA	\$	\$	300.00	6,600.00
34	Reconnect Existing 8-Inch Gravity Sewer to New Manhole	7	EA	\$	\$	500.00	3,500.00
35	Reconnect Existing 12-Inch Gravity Sewer to New Manhole	1	EA	\$	\$	900.00	900.00
36	Reconnect Existing 18-Inch Gravity Sewer to New Manhole	3	EA	\$	\$	2,000.00	6,000.00
37	Reconnect Existing 21-Inch Gravity Sewer to New Manhole	1	EA	\$	\$	4,000.00	4,000.00
38	Pipe Abandonment, Safeload, 18-Inch Pipe	280	LF	\$	\$	50.00	14,000.00
39	Pipe Abandonment, Plug 8-Inch	8	EA	\$	\$	400.00	3,200.00



40	Pipe Abandonment, Plug 18-Inch	5	EA	\$	800.00	\$	4,000.00
41	Video Inspection of New Sewer Pipe	3,627	LF	\$	3.00	\$	10,881.00
42	Tree Removal on 1840 Pershing Road and 520 Southbend Drive	3	EA	\$	3,000.00	\$	9,000.00
43	Bituminous Concrete: Trench Construction, Street	641	SY	\$	90.00	\$	57,690.00
44	Bituminous Concrete: Private Parking Lots / Driveways	757	SY	\$	85.00	\$	64,345.00
45	Portland Cement Concrete Paving: Private Parking Lots / Driveways / Aprons	45	SY	\$	200.00	\$	9,000.00
46	Storm Sewer Removal and Replacement, 12-Inch	80	LF	\$	80.00	\$	6,400.00
47	Site Restoration, Method A	100	SY	\$	10.00	\$	1,000.00
48	Site Restoration, Method B	10,000	SY	\$	2.00	\$	20,000.00
49	Site Restoration, Method C	100	SY	\$	4.00	\$	400.00
50	Seeding, Temporary, Extra as Directed by Engineer	1	SY	\$	4.00	\$	4.00
51	Concrete Curb Removal and Replacement	1,290	LF	\$	44.00	\$	56,766.00
52	Dense Graded Aggregate - DGA, Extra as Directed by Engineer	1	Ton	\$	30.00	\$	30.00
53	No. 9 Crushed Stone, Extra as Directed by Engineer	1	Ton	\$	30.00	\$	30.00
54	No. 57 Crushed Stone, Extra as Directed by Engineer	1,089	Ton	\$	20.00	\$	21,780.00
55	No. 2 Crushed Stone, Extra as Directed by Engineer	1	Ton	\$	30.00	\$	30.00
56	Flowable (Controlled Density) Fill	1	CY	\$	150.00	\$	150.00
57	Concrete Sidewalk	162	SY	\$	90.00	\$	14,580.00
58	Chain Link Fence	320	LF	\$	50.00	\$	16,000.00
59	Bypass Pumping and Setup	1	LS	\$	50,000.00	\$	50,000.00
60	Maintenance of Traffic	1	LS	\$	30,000.00	\$	30,000.00
61	Creek Crossing and Bank Restoration, Pipe Segment P-12	1	LS	\$	7,000.00	\$	7,000.00

62	Concrete Storm Channel Reconstruction	1	LS	\$	\$
				<i>7,000.00</i>	<i>7,000.00</i>
63	Easement and Property Requirements (MOU Conditions)	1	LS	\$	\$
				<i>51,000.00</i>	<i>51,000.00</i>
64	Allowance: Miscellaneous Site Improvements	1	LS	\$500,000.00	\$500,000.00
65	Allowance: Third Party Professional Pre-Construction Photographic Documentation	1	LS	\$3,500.00	\$3,500.00
66	Allowance: Culvert Monitoring	1	LS	\$45,000.00	\$45,000.00
67	Allowance: MOU Condition 3 for 1908 Harrodsburg Road	1	LS	\$10,000.00	\$10,000.00
<b>TOTAL BASE BID (Items 1 thru 67)</b>				\$	<i>4,919,523.00</i>

**TOTAL BASE BID AMOUNT:**

*Four million nine hundred nineteen thousand five hundred twenty-three* Dollars (\$ *4,919,523.00* )

**ADDITIVE ALTERNATE 1**

Item	Description	Qty	Unit	Unit Price	Item Price
1-1	Cut and Cap Existing 4-Inch Lateral Lines, Remove Line Exposed in Creek	4	EA	\$ 500.00	\$ 2,000.00
2-1	8-Inch Gravity Sewer Pipe, <6-Foot Depth, PVC	189	LF	\$ 220.00	\$ 41,580.00
3-1	Standard Manhole, 4-Foot Diameter, 0-Foot to 6.0-Foot Depth	1	EA	\$ 5,400.00	\$ 5,400.00
4-1	Manhole Vertical Foot (VF), 4-Foot Diameter (Standard)	1	VF	\$ 220.00	\$ 220.00
5-1	Chain Link Fence	40	LF	\$ 50.00	\$ 2,000.00
6-1	Site Restoration, Method B (Straw and Seed)	906	SY	\$ 2.00	\$ 1,812.00
7-1	Tree Protection	125	LF	\$ 3.00	\$ 375.00
8-1	PVC (SDR) 35 Gravity Sewer Lateral (Not in Pavement)	3	EA	\$ 2,800.00	\$ 8,400.00
9-1	Install Cleanout	3	EA	\$ 850.00	\$ 2,550.00
10-1	Tee Fittings for Gravity Sewer Lateral Connection (Non-Ductile Iron or Inserta Tee)	3	EA	\$ 450.00	\$ 1,350.00
11-1	Manhole Accessories for Location Within 100-Year Flood Plain	1	EA	\$ 350.00	\$ 350.00
12-1	Storm Sewer Removal and Replacement, 12-Inch	20	LF	\$ 80.00	\$ 1,600.00
13-1	Erosion and Sediment Control and Conformance With SWPP	1	LS	\$ 3,000.00	\$ 3,000.00
14-1	Clearing and Grubbing	1	LS	\$ 4,000.00	\$ 4,000.00
15-1	Video Inspection of New Sewer Pipe	189	LF	\$ 3.00	\$ 567.00
<b>TOTAL ADDITIVE ALTERNATE BID (Items 1-1 thru 15-1)</b>				\$	<b>75,204.00</b>

**TOTAL ALTERNATE 1 AMOUNT:**

Seventy-Five Thousand two hundred  
four Dollars (\$ 75,204.00)

Respectfully Submitted,

FIRM: Tribute Contracting & Consultants, LLC

ADDRESS: 2125 County Rd 1

CITY/STATE/ZIP: South Point, OH 45680

DATE: 06-13-23

BY: 

(must be original signature)

TITLE: Manager/member, Todd Harrah

PHONE: 740-451-1010 FAX: 740-894-3168  
(area code, number & extension)

EMAIL ADDRESS: tharrah88@yahoo.com

OFFICIAL ADDRESS AND PHONE:

2125 County Rd 1

South Point, OH 45680

740-451-1010

(Seal if Bid is by Corporation)

By signing this form, you agree to all the terms and associated forms.



**1.05 STATEMENT OF BIDDER'S QUALIFICATIONS**

The following statement of the Bidder's qualifications is required to be filled in, executed, and submitted with the Bid:

- A. Name of Bidder: Tribute Contracting & Consultants, LLC
- B. Permanent Place of Business: 2125 Co Rd 1, South Point, OH 45680
- C. When Organized: 11-10-2014
- D. Where Incorporated: State of Ohio
- E. Financial Condition:

If specifically requested by the Owner, the apparent low Bidder is required to submit its latest three (3) years audited financial statements to the Owner's Division of Central Purchasing within seven (7) calendar days following the Bid opening.

- F. In the event the Agreement is awarded to the undersigned, Performance, Payment, Erosion and Sediment Control, and Warranty bonds will be furnished by:

Ohio Farmers Insurance Company (Surety)

Signed: Buenda J. Kesh (Representative of Surety)

- G. The following is a list of similar projects performed by the Bidder: (Attach separate sheet if necessary).

<u>NAME</u>	<u>LOCATION</u>	<u>CONTRACT SUM</u>
<u>See attached</u>		

- H. The Bidder has now under contract and bonded the following projects:

<u>NAME</u>	<u>LOCATION</u>	<u>CONTRACT SUM</u>
<u>See attached</u>		

I. List Key Bidder Personnel who will work on this Project.

<u>NAME</u>	<u>POSITION DESCRIPTION</u>	<u>NO. OF YEARS WITH BIDDER</u>
<u>Todd Harrah</u>	<u>Project Manager</u>	<u>8</u>
<u>Larry Davis</u>	<u>General Superintendent</u>	<u>7</u>
<u>Brian Sanders</u>	<u>Superintendent</u>	<u>5</u>
<u>Dave Dick</u>	<u>Foreman</u>	<u>4</u>
<u>Aimee Harrah</u>	<u>HR &amp; EEO</u>	<u>6</u>

J. MWDBE Participation on current bonded projects under contract:

<u>SUBCONTRACTORS (LIST)</u>	<u>PROJECT (SPECIFIC TYPE)</u>	<u>MWDBE</u>	<u>% of WORK</u>
<u>Total View</u>	<u>Milton Sewer</u>	<u>MBE</u>	<u>1%</u>
<u>Total View</u>	<u>Parkersburg Water</u>	<u>MBE</u>	<u>1%</u>
<u>Garcia Surveyors</u>	<u>Newtonsville Sewer</u>	<u>MBE</u>	<u>1%</u>
_____	_____	_____	_____
_____	_____	_____	_____
_____	_____	_____	_____
_____	_____	_____	_____

(USE ADDITIONAL SHEETS IF NECESSARY)

K. We acknowledge that, if we are the apparent low Bidder, we may be required to submit to the Owner within seven (7) calendar days following the Bid Opening, a sworn statement regarding all office management and field management personnel. Additionally, if requested by the Owner, we will within seven (7) days following the request submit audited financial statements and loss history for insurance claims for the three (3) most recent years (or a lesser period if stipulated by the Owner)



**1.06 LIST OF PROPOSED SUBCONTRACTORS**

The following list of proposed subcontractors is required by the Owner to be executed, completed and submitted with the Bid Form. All subcontractors are subject to approval of the Lexington-Fayette Urban County Government. Failure to submit this list completely filled out may be cause for rejection of Bid.

<u>BRANCH OF WORK**</u> (List each major item)	<u>SUBCONTRACTOR</u>	<u>MWDBE</u> (yes/no)	<u>% of WORK</u>
1. <u>Tunneling</u>	Name: <u>Capitol Tunneling</u> Address: <u>2216 Refugee Rd</u> <u>Columbus, OH 43207</u>	<u>no</u>	<u>    </u>
2. <u>Paving</u>	Name: <u>C&amp;R Asphalt</u> Address: <u>415 Rebmann Lane</u> <u>Lexington, KY 40504</u>	<u>no</u>	<u>    </u>
3. <u>Layout</u>	Name: <u>Vision Engineering</u> Address: <u>128 E Reynolds Rd</u> <u>Lexington, KY 40517</u>	<u>yes</u>	<u>1%</u>
4. <u>Testing</u>	Name: <u>Trutest, LLC</u> Address: <u>8202 Cadence Place</u> <u>Louisville, KY 40222</u>	<u>yes</u>	<u>1%</u>
5. <u>Pre-Con Video</u>	Name: <u>Multivista</u> Address: <u>1001 Eastwind Drive, Suite 111</u> <u>Westerville, OH 43081</u>	<u>no</u>	<u>1%</u>
6. <u>Culvert Monitoring</u>	Name: <u>Appalachian Mining and Engineering</u> Address: <u>116 Dennis Dr.</u> <u>Lexington, KY 40503</u>	<u>no</u>	<u>1%</u>

\*\* Such as: Grading, bituminous paving, concrete, seeding and protection, construction staking, etc.

**1.07 AUTHENTICATION OF BID AND STATEMENT OF NON-COLLUSION AND NON-CONFLICT OF INTEREST**

I hereby swear (or affirm) under the penalty for false swearing:

- A. That I am the Bidder (if the Bidder is an individual), a partner of the Bidder (if the Bidder is a partnership), or an officer or employee of the Bidding corporation having authority to sign on its behalf (if the Bidder is a corporation);
- B. That the attached Bid has been arrived at by the Bidder independently, and has been submitted without collusion with, and without any agreement, understanding or planned common course of action, with any other contractor, vendor of materials, supplies, equipment or services described in the Advertisement for Bid, designed to limit independent bidding or competition;
- C. That the contents of the Bid or Bids have not been communicated by the Bidder or its employees or agents to any person not an employee or agent of the Bidder or its surety on any bond furnished, with the Bid or Bids, and will not be communicated to any such person, prior to the official opening of the Bid or Bids;
- D. That the Bidder is legally entitled to enter into the contracts with the Lexington-Fayette Urban County Government, and is not in violation of any prohibited conflict of interest;
- E. (Applicable to corporation only) That as a foreign corporation, we are registered with the Secretary of State, Commonwealth of Kentucky, and authorized to do business in the State ✓ or, that as a domestic corporation, we are in good standing with the Secretary of State, Commonwealth of Kentucky \_\_\_\_\_. [Check the statement applicable.]
- F. This offer is for ninety (90) calendar days from the date this Bid is opened. In submitting the above, it is expressly agreed that, upon proper acceptance by the Lexington-Fayette Urban County Government of any or all items Bid above, an Agreement shall thereby be created with respect to the items accepted.
- G. That I have fully informed myself regarding the accuracy of the statements made in this statement.
- H. That I certify that Subcontractors have not and will not be awarded to any firm(s) that have been debarred from noncompliance with the Federal Labor Standards, Title VI of the Civil Rights Act of 1964 As Amended, Executive Order 11246 As Amended or any other Federal Law.

Tribute Contracting  
& Consultants, LLC

Company

06-13-23

Date

[Signature]

Representative



**1.08 STATEMENT OF EXPERIENCE**

NAME OF INDIVIDUAL: Todd Harrah

POSITION/TITLE: Project Manager

STATEMENT OF EXPERIENCE: Over 30 years experience in underground utility construction

NAME OF INDIVIDUAL: Brian Sanders

POSITION/TITLE: General Superintendent

STATEMENT OF EXPERIENCE: Over 20 years experience in underground utility construction

NAME OF INDIVIDUAL: Larry Davis

POSITION/TITLE: Superintendent

STATEMENT OF EXPERIENCE: Over 30 years experience in underground utility construction

NAME OF INDIVIDUAL: Dave Dick

POSITION/TITLE: Foreman

STATEMENT OF EXPERIENCE: Over 15 years experience in underground utility construction

NAME OF INDIVIDUAL: Aimee Harrah

POSITION/TITLE: HR/EEO

STATEMENT OF EXPERIENCE: Over 7 years experience

\* Include all officers, office management, Affirmative Action officials, and field management personnel. Attach separate sheets if necessary.

### 1.09 TUNNELING CONTRACTOR QUALIFICATIONS

Tunneling Company Name:	Capitol Tunneling Inc
Kentucky Contractor's License Number:	N/A

This Tunneling Contractor Qualifications is required to be completed for each Tunneling Contractor and included with the Bidder's Bid for the Project. To be considered for award of the Contract, Bidder shall provide all information that is requested in Attachment A. If all information is not provided, the Bid will be deemed non-responsive.

Time (in years) that organization has been doing business under present name	53 Years
Name of designated Project Manager	E. Kyle Lucus
Name of designated Field Superintendent	Mark Pennington
Number of Regular Employees of the Organization	40

In addition to completing the above form, the Contractor shall provide, as attachments, the following items:

- Resume of designated Project Manager. See attached
- Resume of designated Field Superintendent. See attached
- Company's existing work commitments. See attached

### 1.10 TUNNELING CONTRACTOR QUALIFICATIONS – EXPERIENCE

This Tunneling Contractor's Qualifications – Experience Information (Attachment B) is required to be completed and included with the Bidder's Bid for the Project. To be considered for award of the Contract, Tunneling Contractor shall demonstrate it has experience performing similar work on other projects.

For **each** tunnel installation method that the Bidder is intending to use on the Project, the Tunneling Contractor shall complete the Project Experience Summary Table(s) outlining experience that the Tunneling Contractor has utilizing that specific tunnel installation method. The table shall be populated with Projects that the Tunneling Contractor completed within the past 10 years. The experience qualifications requirements shall meet the minimum requirements set forth in the specific tunnel specification section.

**E. Kyle Lucus**  
2216 Refugee Road  
Columbus, Ohio 43207  
(614) 444-0255 Phone  
(614) 444-4094 Fax

Current Job Title:

- President / CEO

Construction Operations Education / Training:

- BSCE – University of Kentucky, May 1996
- E.I.T. Certification – April 20, 1996
- OSHA 10 Hour Certification
- OSHA 30 Hour Certification
- OSHA Subpart P-Excavation & Trench Competent Person Training
- Confined Space Trained
- CPR / First Aid Trained
- Licensed Blaster
- RWT
- FDOT Safety Compliant
- CDL Holder

Employment History:

- 1986 – 1994 : Tunnel Laborer
- 1995 – 1996 : Project Labor Foreman
- 1996 – 1998 : Project Manager/Estimator
- 1998 – 2000: Vice President of Engineering
- 2000 – 2005: Vice President / CEO
- 2005 – Present: President / CEO

Current Responsibilities:

- Direct supervision of Project Superintendents, Labor Foreman, and Management personnel
- Responsible for procuring and maintaining manpower and equipment to complete work
- Responsible for pre-bid site investigations, producing accurate cost estimates, completing bid packages and submitting of bids
- Responsible for contract compliance, submittals, project engineering and design, correspondence with Owner/Engineer/Client
- Responsible for monitoring and updating Project schedules
- Responsible for compliance with regulatory agencies such as OSHA, Workmans' Compensation, Unemployment, EPA
- Responsible for enforcement of Company Policies and Procedures including but not limited to: Safety, EEO, Union Compliance and Environmental issues.
- Responsible for the day to day operations required to manage multiple working crews in a 15 state area

## **Mark Pennington**

2216 Refugee Road  
Columbus, Ohio 43207  
(614) 444-0255 Phone  
(614) 444-4094 Fax

### Current Job Title:

- Project Superintendent

### Construction Operations Education / Training:

- OSHA 30 Hour Certification
- SKED Training
- Confined Space Trained
- CPR / First Aid Trained
- Trenching & Excavation Training
- Licensed Blaster
- Dangerous Ordinance License
- RWT Training

### Employment History:

- 1984 – 1990: Tunnel Laborer
- 1990 – 1991: Project Labor Foreman / Blaster
- 1991 – Present: Project Superintendent

### Current Responsibilities:

- Direct supervision of all employees working on the project.
- Responsible for procuring and maintaining manpower and equipment to complete work.
- Responsible for installation of tunnels & bores as required by Project Plans and Specifications.
- Responsible for maintaining project schedules.
- Accurate calculations of material quantities and scheduling of timely deliveries.
- Responsible for enforcement of company policies and procedures including but not limited to Safety, EEO, Union Compliance, and Environmental issues.
- Responsible for maintaining accurate job records including daily reports, time keeping, safety inspections, equipment records, and job site safety meetings.

If the Bidder wishes to include more information than what is specified in the summary table, it may be included as an attachment to the end of Attachment B.

**PROJECT EXPERIENCE SUMMARY TABLE**

	Project 1	Project 2	Project 3
Project Name			
Tunnel Installation Method(s)			
Year(s) Project Occurred			
Owner			
Owner's Phone Number			
Original and Final Contract Price			
Original and Final Contract Times (days)			
Carrier Pipe Material and Diameter			
Casing or Tunnel Lining Type and Diameter			
Carrier Pipe Grouted in Place (Y / N)			
Total Tunnel Length (feet) 2,000 LF (min.)			
Range of Tunnel Depth (feet)			
Rock Excavation Required (Y / N)			
Temporary or Permanent Shaft w/invert below groundwater table (Y / N)			

**SEE**



Project Number	Customer	Project Name	Location of Project	Contract Amount	% Complete	Backlog
21-B-120	Confidential	ODOT SR 32 Interchange	Clermont County, OH	\$586,047	55%	\$263,721
21-B-129	Confidential	IR70/Brice RD ODOT 220200	Columbus, OH	\$672,504	95%	\$33,625
21-B-130	Confidential	Sanitary Sewer Rehab & Lift Station Relocation	Cabell County, City of Milton, WV	\$326,000	60%	\$130,400
22-B-101	Confidential	Vayvlew, Planeview & Murwood	Bevercreek, OH	\$603,200	65%	\$211,120
22-B-105	Confidential	MOT/IR 75- ODOT 220366	Moraine, OH	\$646,114	50%	\$323,057
22-B-114	Confidential	Clover Valley Sanitary	New Albany, OH	\$846,450	95%	\$42,323
22-B-115	Confidential	Allen Ave SE Sanitary	Canton, OH	\$406,260	95%	\$20,313
22-B-116	Confidential	CSO #6 & 7 Separation	Steubenville, OH	\$377,570	60%	\$151,028
22-B-121	Confidential	Price Road Water Main Replacement	Clermont County, OH	\$198,645	5%	\$188,713
22-B-122	Confidential	Cosgray Road & Woodsview Way	Hilliard, OH	\$67,620	25%	\$50,715
22-B-126	Confidential	West Hickman Trunk E Sewer	Lexington, KY	\$771,308	0%	\$771,308
22-B-127	Confidential	Dekalb, Steuben County	R-42695-A	\$84,165	0%	\$84,165
22-B-130	Confidential	Farms at Indian Run	Union County, OH	\$146,880	0%	\$146,880
22-C-133	Confidential	I-76 PTC Big Beaver River Bridge	Beaver County, PA	\$3,156,244	0%	\$3,156,244
22-B-134	Confidential	Villages at Galloway	Franklin County, OH	\$32,890	0%	\$32,890
22-B-135	Confidential	Diamond Pet	Rushville, IN	\$190,440	25%	\$142,830
22-B-136	Confidential	Dublin Road 30" Watermain	Columbus, OH	\$462,805	0%	\$462,805
22-B-137	Confidential	R-39821	Marion County, IN	\$344,200	0%	\$344,200
22-B-138	Confidential	CSO 083 & 472 Dynamic Overflow	Cincinnati, Ohio	\$157,035	5%	\$149,183
22-B-139	Confidential	Mt. Carmel Northwest Health Campus	Dublin, OH	\$88,900	0%	\$88,900
22-B-140	Confidential	Benchmark 2 Culvert	Floyds Knobs, IN	\$119,700	0%	\$119,700
				Total Balance to Complete		\$6,914,120

## 1.11 EQUAL OPPORTUNITY AGREEMENT

### The Law

- \* Title VII of the Civil Rights Act of 1964 (amended 1972) states that it is unlawful for an employer to discriminate in employment because of race, color, religion, sex, age (40-70 years) or national origin.
- \* Executive Order No. 11246 on Nondiscrimination under Federal contract prohibits employment discrimination by contractor and subcontractor doing business with the Federal Government or recipients of Federal funds. This order was later amended by Executive Order No. 11375 to prohibit discrimination on the basis of sex.
- \* Section 503 of the Rehabilitation Act of 1973 States:

*The Contractor will not discriminate against any employee or applicant for employment because of physical or mental handicap.*

- \* Section 2012 of the Vietnam Era Veterans Readjustment Act of 1973 requires Affirmative Action on behalf of disabled veterans and veterans of the Vietnam Era by contractors having Federal Contracts.
- \* Section 206 (A) of Executive Order 12086, Consolidation of Contract Compliance Functions for Equal Employment Opportunity, states:

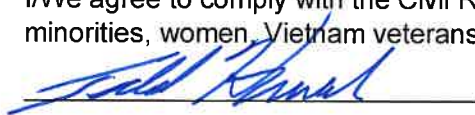
*The Secretary of Labor may investigate the employment practices of any Government contractor or sub-contractor to determine whether or not the contractual provisions specified in Section 202 of this order have been violated.*

The Lexington-Fayette Urban County Government practices Equal Opportunity in recruiting, hiring and promoting. It is the Government's intent to affirmatively provide employment opportunities for those individuals who have previously not been allowed to enter into the mainstream of society. Because of its importance to the local Government, this policy carries the full endorsement of the Mayor, Commissioners, Directors, and all supervisory personnel. In following this commitment to Equal Employment Opportunity and because the Government is the benefactor of the Federal funds, it is both against the Urban County Government policy and illegal for the Government to let contracts to companies which knowingly or unknowingly practice discrimination in their employment practices. Violation of the above mentioned ordinances may cause an Agreement to be canceled and the contractor may be declared ineligible for future consideration.

Please sign this statement in the appropriate space acknowledging that you have read and understand the provisions contained herein. Return this document as part of your application packet.

### Bidders

I/We agree to comply with the Civil Rights Laws listed above that govern employment rights of minorities, women, Vietnam veterans, handicapped, and aged persons.



Signature

Tribute Contracting & Consultants, LLC

Name of Business



The Entity (regardless of whether construction Contractor, non-construction Contractor or supplier) agrees to provide equal opportunity in employment for all qualified persons, to prohibit discrimination in employment because of race, color, creed, national origin, sex or age, and to promote equal employment through a positive, continuing program from itself and each of its sub-contracting agents. This program of equal employment opportunity shall apply to every aspect of its employment policies and practices.

The Kentucky Equal Employment Opportunity Act of 1978 (KRS 45.560-45.640) requires that any county, city, town, school district, water district, hospital district, or other political subdivision of the state shall include in directly or indirectly publicly funded contracts for supplies, materials, services, or equipment hereinafter entered into the following provisions:

During the performance of this contract, the contractor agrees as follows:

- (1) The contractor will not discriminate against any employee or applicant for employment because of race, color, religion, sex, age or national origin;*
- (2) The contractor will state in all solicitations or advertisements for employees placed by or on behalf of the contractors that all qualified applicants will receive consideration for employment without regard to race, color, religion, sex, age or national origin;*
- (3) The contractor will post notices in conspicuous places, available to employees and applicants for employment, setting forth the provisions of the non-discrimination clauses required by this section; and*
- (4) The contractor will send a notice to each labor union or representative of workers with which he has a collective bargaining agreement or other contract or understanding advising the labor union or workers' representative of the contractor's commitments under the nondiscrimination clauses.*

The Act further provides:

KRS 45.610. Hiring minorities - Information required

- (1) For the length of the contract, each contractor shall hire minorities from other sources within the drawing area, should the union with which he has collective bargaining agreements be unwilling to supply sufficient minorities to satisfy the agreed upon goals and timetable.*
- (2) Each contractor shall, for the length of the contract, furnish such information as required by KRS 45.560 to KRS 45.640 and by such rules, regulations and orders issued pursuant thereto and will permit access to all books and records pertaining to his employment practices and work sites by the contracting agency and the department for purposes of investigation to ascertain compliance with KRS 45.560 to 45.640 and such rules, regulations and orders issued pursuant thereto.*

KRS 45.620. Action against contractor - Hiring of minority contractor or subcontractor

- (1) If any contractor is found by the department to have engaged in an unlawful practice under this chapter during the course of performing under a contract or subcontract covered under KRS 45.560 to 45.640, the department shall so certify to the contracting*

*agency and such certification shall be binding upon the contracting agency unless it is reversed in the course of judicial review.*

- (2) If the contractor is found to have committed an unlawful practice under KRS 45.560 to 45.640, the contracting agency may cancel or terminate the contract, conditioned upon a program for future compliance approved by the contracting agency and the department. The contracting agency may declare such a contractor ineligible to bid on further contracts with that agency until such time as the contractor complies in full with the requirements of KRS 45.560 to 45.640.*
- (3) The equal employment provisions of KRS 45.560 to 45.640 may be met in part by a contractor by subcontracting to a minority contractor or subcontractor. For the provisions of KRS 45.560 to 45.640, a minority contractor or subcontractor shall mean a business that is owned and controlled by one or more persons disadvantaged by racial or ethnic circumstances.*

KRS 45.630 Termination of existing employee not required, when

*Any provision of KRS 45.560 to 45.640 notwithstanding, no contractor shall be required to terminate an existing employee upon proof that that employee was employed prior to the date of the contract.*

KRS 45.640 Minimum skills

*Nothing in KRS 45.560 to 45.640 shall require a contractor to hire anyone who fails to demonstrate the minimum skills required to perform a particular job.*

In the case of an Agreement exceeding \$250,000, the Contractor will be required within seven (7) days following the Bid Opening to furnish evidence that its work-force in Kentucky is representative of the available work-force in the area from which it draws employees, or to supply an Affirmative Action plan which will achieve such representation during the life of the Contract.

1.12 LFUCG MWDBE PARTICIPATION FORM




LFUCG Bid/RFP/Quote Reference No. 49-2023

The MWDBE and/or Veteran subcontractors listed have agreed to participate on this Bid/RFP/Quote. If any substitution is made or the total value of the Work is changed prior to or after the job is in progress, it is understood that those substitutions must be submitted to Central Purchasing for approval immediately.

MWDBE Company, Name, Address, Phone, Email	Work to be Performed	Total Dollar Value of the Work	% Value of Total Contract
Vision Engineering Jihad Hallany 128 E Reynolds Rd Lexington, KY 40517 859-559-0516	Layout	TBD (unit prices)	TBD
TruTest, LLC Kristi Conrad 8202 Cadence Place Louisville, KY 40222 502-552-5142	Testing	TBD (unit prices)	TBD

The undersigned company representative submits the above list of MWDBE firms to be used in accomplishing the work contained in this Bid/RFP/Quote. Any misrepresentation may result in the termination of the Contract and/or be subject to applicable Federal and State laws concerning false statements and false claims.

Tribute Contracting & Consultants, LLC   
 Company Company Representative

06-13-23  
 Date

Todd Harrah, manager/member  
 Title

**1.13 LFUCG MWDBE SUBSTITUTION FORM**


LFUCG Bid/RFP/Quote Reference No. 49-2023



The substituted MWDBE and/or Veteran subcontractors listed below have agreed to participate on this Bid/RFP/Quote. These substitutions were made prior to or after the job was in progress. These substitutions were made for reasons stated below and are now being submitted to Central Purchasing for approval. By the authorized signature of a representative of our company, we understand that this information will be entered into our file for this project.

SUBSTITUTED MWDBE Company Name, Address, Phone, Email	MWDBE Formally Contracted/ Name, Address, Phone, Email	Work to Be Performed	Reason for the Substitution	Total Dollar Value of the Work	% Value of Total Contract
TBD - will be completed & submitted if needed/awarded project					

The undersigned acknowledges that any misrepresentation may result in termination of the Contract and/or be subject to applicable Federal and State laws concerning false statements and false claims.

Tribute Contracting & Consultants, LLC   
 Company Company Representative

06-13-23  
 Date

Todd Harrah, Manager/member  
 Title

**1.14 MWDBE QUOTE SUMMARY FORM**

LFUCG Bid/RFP/Quote Reference No. 49-2023



The undersigned acknowledges that the minority and/or veteran subcontractors listed on this form did submit a quote to participate on this project.

Company Name <u>Tribute Contracting &amp; Consultants, LLC</u>	Contact Person <u>Todd Harrah</u>
Address/Phone/Email <u>2125 Co Rd 1, South Point, OH 45680</u> <u>740-451-1010, tharrah88@yahoo.com</u>	Bid Package / Bid Date <u>Wolf Run Trunk F</u>

MWDBE Company Address	Contact Person	Contact Information (work phone, Email, cell)	Date Contacted	Services to be performed	Method of Communication (email, phone meeting, ad, event, etc)	Total dollars(\$) Do Not Leave Blank (Attach Documentation)	DBE * AA HA AS NA Female	Veteran
<u>Vision Engineering Lexington, KY</u>	<u>Jihad Hallani</u>	<u>859-559-0516</u>	<u>06-05-23</u>	<u>Layout</u>	<u>Phone</u>	<u>TBD unit price</u>	<u>MBE</u>	<u>no</u>
<u>TruTest, LLC Louisville, KY</u>	<u>Kristi Conrad</u>	<u>502-552-5142</u>	<u>06-06-23</u>	<u>testing</u>	<u>phone</u>	<u>TBD unit price</u>	<u>WBE</u>	<u>no</u>

\*(DBE designation / AA=African American / HA= Hispanic American/AS = Asian American/Pacific Islander / NA= Native American)

The undersigned acknowledges that all information is accurate. Any misrepresentation may result in termination of the Contract and/or be subject to applicable Federal and State laws concerning false statements and claims.

Tribute Contracting & Consultants, LLC  
 Company  
06-13-23  
 Date

Todd Harrah  
 Company Representative  
Todd Harrah, Manager/member  
 Title

**1.15 LFUCG SUBCONTRACTOR MONTHLY PAYMENT REPORT**

LFUCG Bid/RFP/Quote Reference No. 49-2023



The LFUCG has a 10% goal plan adopted by city council to increase the participation of minority and women owned businesses in the procurement process. The LFUCG also has a 3% goal plan adopted by cited council to increase the participation of veteran owned businesses in the procurement process. In order to measure that goal LFUCG will track spending with MWDBE vendors on a monthly basis. By the signature below of an authorized company representative, you certify that the information is correct, and that each of the representations set forth below is true. Any misrepresentation may result in termination of the contract and/or prosecution under applicable Federal and State laws concerning false statements and false claims. Please submit this form monthly to the Division of Central Purchasing/ 200 East Main Street / Room 338 / Lexington, KY 40507.

**Total Contract Amount Awarded to Prime Contractor for this Project**

TBD

Project Name/ Contract # <u>Wolf Run Trunk F</u>	Work Period/ From: <u>TBD</u> To:
Company Name: <u>Tribute Contracting &amp; Consultants, LLC</u>	Address: <u>2125 County Rd 1 South Point, OH 45680</u>
Federal Tax ID: <u>47-2371505</u>	Contact Person: <u>Todd Harrah</u>

Subcontractor Vendor ID (name, address, phone, email)	Description of Work	Total Subcontract Amount	% of Total Contract Awarded to Prime for this Project	Total Amount Paid for this Period	Purchase Order number for subcontractor work (please attach PO)	Scheduled Project Start Date	Scheduled Project End Date
<u>TBD</u>							

By the signature below of an authorized company representative, you certify that the information is correct, and that each of the representations set forth below is true. Any misrepresentations may result in the termination of the Contract and/or prosecution under applicable Federal and State laws concerning false statements and false claims.

Tribute Contracting & Consultants, LLC  
Company

  
Company Representative

06-13-23  
Date

Todd Harrah, Manager/member  
Title





## 1.16 LFUCG STATEMENT OF GOOD FAITH EFFORTS

LFUCG Bid/RFP/Quote Reference No. 49-2023

By the signature below of an authorized company representative, we certify that we have utilized the following Good Faith Efforts to obtain the maximum participation by MWDBEs and/or Veterans on the project and can supply the appropriate documentation.

- Advertised opportunities to participate in the contract in at least two (2) publications of general circulation media; trade and professional association publications; small and minority business or trade publications; and publications or trades targeting minority, women and disadvantaged businesses not less than fifteen (15) days prior to the deadline for submission of bids to allow MWDBE firms to participate.
- Included documentation of advertising in the above publications with the bidders good faith efforts package
- Attended LFUCG Central Purchasing Economic Inclusion Outreach event
- Attended pre-bid meetings that were scheduled by LFUCG to inform MWDBEs of subcontracting opportunities
  
- Sponsored Economic Inclusion event to provide networking opportunities for prime contractors and MWDBE firms
- Requested a list of MWDBE subcontractors or suppliers from LFUCG Economic Engine and showed evidence of contacting the companies on the list(s).
- Contacted organizations that work with MWDBE companies for assistance in finding certified MWBDE firms to work on this project. Those contacted and their responses should be a part of the bidder's good faith efforts documentation.
- Sent written notices, by certified mail, email or facsimile, to qualified, certified MWDBEs soliciting their participation in the contract not less than seven (7) days prior to the deadline for submission of bids to allow them to participate effectively.
- Followed up initial solicitations by contacting MWDBEs to determine their level of interest.
- Provided the interested MWBDE firm with adequate and timely information about the plans, specifications, and requirements of the contract.
- Selected portions of the work to be performed by MWDBE firms in order to increase the likelihood of meeting the contract goals. This includes, where appropriate, breaking out contract work items into economically feasible units to facilitate MWDBE participation, even when the prime contractor may otherwise perform these work items with its own workforce
- Negotiated in good faith with interested MWDBE firms not rejecting them as unqualified without sound reasons based on a thorough investigation of their



capabilities. Any rejection should be so noted in writing with a description as to why an agreement could not be reached.

- Included documentation of quotations received from interested MWDBE firms which were not used due to uncompetitive pricing or were rejected as unacceptable and/or copies of responses from firms indicating that they would not be submitting a bid.
- Bidder has to submit sound reasons why the quotations were considered unacceptable. The fact that the bidder has the ability and/or desire to perform the contract work with its own forces will not be considered a sound reason for rejecting a MWDBE quote. Nothing in this provision shall be construed to require the bidder to accept unreasonable quotes in order to satisfy MWDBE goals.
- Made an effort to offer assistance to or refer interested MWDBE firms to obtain the necessary equipment, supplies, materials, insurance and/or bonding to satisfy the work requirements of the bid proposal
- Made efforts to expand the search for MWBE firms beyond the usual geographic boundaries.
- Other - any other evidence that the bidder submits which may show that the bidder has made reasonable good faith efforts to include MWDBE participation.

Failure to submit any of the documentation requested in this section may be cause for rejection of bid. Bidders may include any other documentation deemed relevant to this requirement. Documentation of Good Faith Efforts are to be submitted with the Bid, if the participation Goal is not met.

The undersigned acknowledges that all information is accurate. Any misrepresentations may result in termination of the contract and/or be subject to applicable Federal and State laws concerning false statements and claims.

Tribute Contracting & Consultants, LLC

Company



Company Representative

06-13-23

Date

Todd Harrah, Manager/member

Title


**1.17 EQUAL EMPLOYMENT OPPORTUNITY AFFIRMATIVE ACTION POLICY**

It is the policy of Tribute Contracting & Consultants, LLC  
(Name of Bidder)

to assure that all applicants for employment and all employees are treated on a fair and equitable basis without regard to their race, religion, sex, color, handicap, natural origin or age.

Such action shall include employment, promotion, demotion, recruitment or recruitment advertising, layoff or termination, rates of pay and other forms of compensation, and selection for training, whether apprenticeship and/or on-the-job-training.

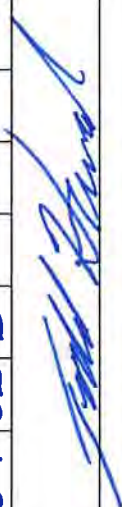
Furthermore, this company agrees to make special recruitment efforts to hire the protected class whenever feasible. This company also agrees to adhere to all applicable federal, state, and local laws relating to Equal Employment Opportunity for all individuals.

  
\_\_\_\_\_  
Todd Harrah, Manager/member  
06-13-23

1.18 WORKFORCE ANALYSIS FORM

Name of Organization: Tribute Contracting & Consultants, LLC

Categories	Total		White (not Hispanic or Latino)		Hispanic or Latino		Black or African-American (not Hispanic or Latino)		Native Hawaiian and other Pacific Islander (not Hispanic or Latino)		Asian (not Hispanic or Latino)		American Indian or Alaskan Native (not Hispanic or Latino)		Two or more races (not Hispanic or Latino)		Total	
	M	F	M	F	M	F	M	F	M	F	M	F	M	F	M	F	M	F
Administrators		2	2	0													2	0
Professionals																		
Superintendents		3	3	0													3	0
Supervisors																		
Foremen		9	9	0													9	0
Technicians																		
Protective Service																		
Para-Professionals																		
Office/Clerical		5	3	2													3	2
Skilled Craft		65	65	0													65	0
Service/Maintenance																		
Total		84	82	2													82	2

Prepared By: 

Date: 4/13/23

1.19

EVIDENCE OF INSURABILITY

LEXINGTON-FAYETTE UBAN COUNTY GOVERNMENT CONTRUCTION PROJECT

(Use separate form for each Agency or Brokerage agreeing to provide coverage)

Names Insured: Tribute Contracting & Consultants, LLC  
 Address: 2125 County Rd 1, South Point, OH 45680  
 Project to be insured: WOLF RUN TRUNK F

In lieu of obtaining certificates of insurance at this time, the undersigned agrees to provide the above Named Insured with the minimum coverage listed below. These are outlined in the Insurance and Risk Management of Section 00600 - Bonds and Certifications, including all requirements, and conditions:

Article Items	Coverage	Minimum Limits and Policy Requirements	Limits Provided to Insured	Name of Insurer	A.M. Best's	
					Code	Rating
1.05.D.1	CGL	\$1,000,000/per occ., \$2,000,000/aggregate or \$2,000,000 combined single limit Requirements (a) through (e)	1,000,000-bcc 2,000,000-agg	Travelers	25673	A
1.05.D.1	Auto	Combined single \$1,000,000/per occ. aggregate Requirements (a) through (c)	1,000,000	Travelers		A
1.05.D.1	WC	\$ Statutory	Statutory	Travelers		A
1.05.D.1	Employer's Liability	\$500,000	1,000,000	Travelers		A

Section 00600 includes required provisions, statements regarding insurance requirements, and the undersigned agrees to abide by all provisions for the coverage's checked above unless stated otherwise when submitting

Assured Partners of WV  
 Agency or Brokerage Brenda Kash  
1002 3rd Avenue  
 Street Address  
Huntington, WV 25701  
 City  
304-736-2222  
 Telephone Number  
 Name of Authorized Representative  
Agent  
 Title  
Buenda S. Kash  
 Authorized Signature  
06-13-23  
 Date

NOTE: Authorized signatures may be the agent's if agent has placed insurance through an agency agreement with the insurer. If insurance is brokered, authorized signature must be that of authorized representative of insurer.

IMPORTANT: CONTRACT MAY NOT BE AWARDED IF A COMPLETED AND SIGNED COPY OF THIS FORM FOR ALL COVERAGES LISTED ABOVE IS NOT PROVIDED.

**1.20 DEBARRED FIRMS**

**PROJECT NAME:** Wolf Run Trunk Sewer Line F Wastewater System Improvements

**LFUCG BID NO.:** 49-2023

**LEXINGTON-FAYETTE URBAN COUNTY GOVERNMENT  
LEXINGTON, KY**

All prime Contractors shall certify that Subcontractors have not and will not be awarded to any firms that has been debarred for noncompliance with the Federal Labor Standards, Title VI of the Civil Rights Act of 1964 As Amended, Executive Order 11246 As Amended or any other Federal Law.

All Bidders shall complete the Debarment Certification in duplicate and submit both copies to the Owner with the Bid Form. The Owner (grantee) shall transmit one copy to the Lexington-Fayette Urban County Government, Division of Community Development within fourteen (14) days after Bid opening.

The undersigned hereby certifies that the firm of Tribute Contracting & Consultants, LLC has not and will not award a subcontract, in connection with any Agreement award to it as the result of this bid, to any firm that has been debarred for noncompliance with the Federal Labor Standards, Title VI of the Civil Rights Act of 1964, Executive Order 11246 As Amended or any Federal Law.

Tribute Contracting & Consultants, LLC  
Name of Firm Submitting Bid

Todd Harrah  
Signature of Authorized Official

Todd Harrah, Manager/Member  
Title

06-13-23  
Date

**1.21 DEBARMENT CERTIFICATION**

- A. All Contractors/Subcontractors shall complete this certification.
- B. The Contractor/Subcontractor certifies in accordance with Executive Order 12549 (Debarment and Suspension 2/18/86) that to the best of its knowledge and belief, that it and its principals:
  - 1. Are not presently debarred, suspended, proposed for debarment, declared negligible, or voluntarily excluded from covered transactions or contract by any Federal department or agency for noncompliance with the Federal Labor Standards, Title VI of the Civil Rights Act of 1964 As Amended, Executive Order 11246 As Amended or any other Federal Law.
    - a. Have not within a three year period preceding this Bid been convicted of or had a civil judgment rendered against them for commission of fraud or a criminal offense in connection with obtaining, attempting to obtain, or performing a public (Federal, State or local) transaction or contract under a public transaction; violation of Federal or State antitrust statutes or commission of embezzlement, theft, forgery, bribery, falsification or destruction of records, making false statements or receiving stolen property;
    - b. Are not presently indicted for or otherwise criminally or civilly charged by a government entity (Federal, State or local) with commission of any of the offenses enumerated in paragraph (1)(a) of this certification; and
    - c. Have not within a three (3) year period preceding this Bid has one or more public (Federal, State or local) transactions or contracts terminated for cause or default.
  - 2. Where the Contractor is unable to certify to any of the statements in this certification, such prospective contractors shall attach an explanation to this certification form.

Firm Name: Tribute Contracting & Consultants, LLC

Project: WOLF Run Trunk F

Printed Name: Todd Harrah

Title of Authorized Representative: manager/member

Signature: 

Date: 06-13-23



**1.22 CERTIFICATION REGARDING LOBBYING**

**Certification for Contracts, Grants, Loans, and Cooperative Agreements**


- A. The undersigned certifies, to the best of his or her knowledge and belief, that:
1. No Federal appropriated funds have been paid or will be paid, by or on behalf of the undersigned, to any person for influencing or attempting to influence an officer or employee of an agency, a Member of Congress, an officer or employee of Congress, or an employee of a Member of Congress in connection with the awarding of any Federal contract, the making of any Federal grant, the making of any Federal loan, the entering into of any cooperative agreement, and the extension, continuation, renewal, amendment, or modification of any Federal contract, grant, loan, or cooperative agreement.
  2. If any funds other than Federal appropriated funds have been paid or will be paid to any person for influencing or attempting to influence an officer or employee of any agency, a Member of Congress, an officer or employee of Congress, or an employee of a Member of Congress in connection with this Federal contract, grant, loan, or cooperative agreement, the undersigned shall complete and submit Standard Form-LLL, "Disclosure Form to Report Lobbying," in accordance with its instructions.
  3. The undersigned shall require that the language of this certification be included in the award documents for all sub-awards at all tiers (including subcontracts, sub-grants, and contracts under grants, loans, and cooperative agreements) and that all sub-recipients shall certify and disclose accordingly.
- B. This certification is a material representation of fact upon which reliance was placed when this transaction was made or entered into. Submission of this certification is a prerequisite for making or entering into this transaction imposed by Section 1352, Title 31, U.S. Code. Any person who fails to file the required certification shall be subject to a civil penalty for not less than \$10,000 and not more than \$100,000 for each such failure.

Todd Harrah, Manager/Member

Typed Name & Title of Authorized Representative

Signature of Authorized Representative

Date

  
06-13-23

\_\_\_\_ I am unable to certify to the above statements. My explanation is attached.

**1.23 BID BOND**

**Bond Number:** \_\_\_\_\_ Tribute Contracting & Consultants, LLC  
KNOW ALL MEN BY THESE PRESENTS, that we \_\_\_\_\_

as principal (the "Principal") and Ohio Farmers Insurance Company

hereinto called Surety, are held and firmly bound unto

LEXINGTON-FAYETTE URBAN COUNTY GOVERNMENT  
200 East Main Street, Third Floor  
Lexington, Kentucky 40507

as obligee (the "Obligee"), in the penal sum of Five Percent (5%) of Bid Amount dollars for the payment of which sum well and truly to be made, the said Principal and the said Surety, bind ourselves, our heirs, executors, administrators, successors and assigns, jointly and severally, firmly by these presents.

WHEREAS, the Principal has submitted a bid for Wolf Run Trunk Sewer Line F Wastewater System Improvements

NOW, THEREFORE, if the Obligee shall accept the bid of the Principal within the period specified therein, or, if no period be specified, within ninety (90) days after opening, and the Principal shall enter into a contract with the Obligee in accordance with the terms of such bid, and give such bond or bonds as may be specified in the bidding or contract documents, or in the event of the failure of the Principal to enter into such contract and give such bond or bonds, if the Principal shall pay to the Obligee the difference in money not to exceed the penal sum hereof between the amount specified in said bid and such larger amount for which the Obligee may in good faith contract with another party to perform the work covered by said bid, then this obligation shall be null and void; otherwise to remain in full force and effect. In no event shall the liability hereunder exceed the penal sum thereof.

PROVIDED AND SUBJECT TO THE CONDITION PRECEDENT, that any claim by Obligee under this bond must be submitted in writing by registered mail, to the attention of the Surety Law Department at the address above, within 120 days of the date of this bond. Any suit under this bond must be instituted before the expiration of one (1) year from the date of this bond. If the provisions of this paragraph are void or prohibited by law, the minimum period of limitation available to sureties as a defense in the jurisdiction of the suit shall apply.

Continued on next page.



DATED as of this 13th day of June, 2023.

WITNESS / ATTEST:


  
Principal (Secretary)

Tribute Contracting & Consultants, LLC

Principal

By:  (seal)

Todd Harrah, Manager/Member  
Name and Title

  
Surety (Secretary)

Ohio Farmers Insurance Company

Surety

By:  (seal)

Brenda J. Kash, Attorney-in-fact  
Name and Title

  
KY Resident Agent

THIS POWER OF ATTORNEY SUPERCEDES ANY PREVIOUS POWER BEARING THIS SAME POWER # AND ISSUED PRIOR TO 07/20/21, FOR ANY PERSON OR PERSONS NAMED BELOW.

POWER NO. 4750592 01

General Power of Attorney

Westfield Insurance Co. Westfield National Insurance Co. Ohio Farmers Insurance Co. Westfield Center, Ohio

CERTIFIED COPY

Know All Men by These Presents, That WESTFIELD INSURANCE COMPANY, WESTFIELD NATIONAL INSURANCE COMPANY and OHIO FARMERS INSURANCE COMPANY, corporations, hereinafter referred to individually as a "Company" and collectively as "Companies," duly organized and existing under the laws of the State of Ohio, and having its principal office in Westfield Center, Medina County, Ohio, do by these presents make, constitute and appoint C. DAVID ROBINSON, BRENDA J. KASH, ZACHARY R. KELLER, PATRICIA G. STUTLER, JOINTLY OR SEVERALLY

of ONA and State of WV its true and lawful Attorney(s)-in-Fact, with full power and authority hereby conferred in its name, place and stead, to execute, acknowledge and deliver any and all bonds, recognizances, undertakings, or other instruments or contracts of suretyship.

LIMITATION: THIS POWER OF ATTORNEY CANNOT BE USED TO EXECUTE NOTE GUARANTEE, MORTGAGE DEFICIENCY, MORTGAGE GUARANTEE, OR BANK DEPOSITORY BONDS

and to bind any of the Companies thereby as fully and to the same extent as if such bonds were signed by the President, sealed with the corporate seal of the applicable Company and duly attested by its Secretary, hereby ratifying and confirming all that the said Attorney(s)-in-Fact may do in the premises. Said appointment is made under and by authority of the following resolution adopted by the Board of Directors of each of the WESTFIELD INSURANCE COMPANY, WESTFIELD NATIONAL INSURANCE COMPANY and OHIO FARMERS INSURANCE COMPANY

"Be It Resolved, that the President, any Senior Executive, any Secretary or any Fidelity & Surety Operations Executive or other Executive shall be and is hereby vested with full power and authority to appoint any one or more suitable persons as Attorney(s)-in-Fact to represent and act for and on behalf of the Company subject to the following provisions:

"The Attorney in Fact may be given full power and authority for and in the name of and on behalf of the Company, to execute, acknowledge and deliver any and all bonds, recognizances, contracts, agreements of indemnity and other conditional or obligatory undertakings and any and all notices and documents cancelling or terminating the Company's liability thereunder, and any such instruments so executed by any such Attorney-in-Fact shall be as binding upon the Company as if signed by the President and sealed and attested by the Corporate Secretary."

"Be It Further Resolved, that the signature of any such designated person and the seal of the Company heretofore or hereafter affixed to any power of attorney or any certificate relating thereto by facsimile, and any power of attorney or certificate bearing facsimile signatures or facsimile seal shall be valid and binding upon the Company with respect to any bond or undertaking to which it is attached." (Each adopted at a meeting held on February 8, 2000)

In Witness Whereof, WESTFIELD INSURANCE COMPANY, WESTFIELD NATIONAL INSURANCE COMPANY and OHIO FARMERS INSURANCE COMPANY have caused these presents to be signed by their National Surety Leader and Senior Executive and their corporate seals to be hereto affixed this 20th day of JULY A.D. 2021

Corporate Seals Affixed



WESTFIELD INSURANCE COMPANY WESTFIELD NATIONAL INSURANCE COMPANY OHIO FARMERS INSURANCE COMPANY

By Gary W. Stumper, National Surety Leader and Senior Executive

State of Ohio County of Medina ss

On this 20th day of JULY A.D. 2021 before me personally came Gary W. Stumper to me known, who, being by me duly sworn, did depose and say, that he resides in Hartford, CT; that he is National Surety Leader and Senior Executive of WESTFIELD INSURANCE COMPANY, WESTFIELD NATIONAL INSURANCE COMPANY and OHIO FARMERS INSURANCE COMPANY, the companies described in and which executed the above instrument; that he knows the seals of said Companies; that the seals affixed to said instrument are such corporate seals that they were so affixed by order of the Boards of Directors of said Companies; and that he signed his name thereto by like order

Notarial Seal Affixed



David A. Kotnik

David A. Kotnik, Attorney at Law, Notary Public My Commission Does Not Expire (Sec. 147.03 Ohio Revised Code)

State of Ohio County of Medina ss

I, Frank A. Carrino, Secretary of WESTFIELD INSURANCE COMPANY, WESTFIELD NATIONAL INSURANCE COMPANY and OHIO FARMERS INSURANCE COMPANY, do hereby certify that the above and foregoing is a true and correct copy of a Power of Attorney, executed by said Companies, which is still in full force and effect; and furthermore, the resolutions of the Boards of Directors set out in the Power of Attorney are in full force and effect

In Witness Whereof, I have hereunto set my hand and affixed the seals of said Companies at Westfield Center, Ohio, this 13th day of June A.D. 2023



Frank A. Carrino Secretary

Frank A. Carrino, Secretary



**WESTFIELD™**

AUTHORIZATION AND CONSENT TO THE USE OF ELECTRONIC SEAL ADDENDUM (APRIL 22, 2020)

Due to logistical issues associated with the use of traditional seals during this COVID-19 pandemic, Westfield Insurance Company and/or Westfield National Insurance Company and/or Ohio Farmers Insurance Company (collectively the "Surety") has authorized its Attorney-in-Fact to affix the Surety's corporate seal to any bond executed on behalf of the Surety by any such Attorney-in-Fact by attaching this Addendum to said bond.

To the extent this Addendum is attached to a bond that is executed on behalf of the Surety by its Attorney-in-Facts, the Surety hereby agrees that the seal below shall be deemed affixed to said bond to the same extent as if its raised corporate seal was physically affixed to the face of the bond.



Thank you,

**Gary W. Stumper**  
National Surety Leader

# **POWER OF ATTORNEY**

**(Attach to Bid Bond)**

**END OF SECTION**

**Current Contracts on Hand:**

- 1) Beckley City Avenue Sanitary & Storm Rehab – 95% Complete**
  - a. Install approx. 2,600LF of 4-12” PVC & DI Sanitary and approx. 1,000LF of 6-12” PVC Storm Sewer
  - b. Owner: Beckley Sanitary Board, John Peplowski, 304-256-1760
  - c. Contract Amount: \$788,491.00
  - d. Engineer: Thrasher Group, Joe Boggs, 304-431-7800
  - e. Anticipated Completion: June 2023
  
- 2) Mingo Beech Creek Waterline Extension – 98% Complete**
  - a. Install approx. 73,000LF of 2-8” Water line & 1 Booster Pump Station
  - b. Owner: Mingo PSD, JB Heflin, 304-235-2244
  - c. Contract Amount: \$3,930,712.40
  - d. Engineer: EL Robinson, Mark McGettigan, 304-776-7473
  - e. Anticipated Completion: June 2023
  
- 3) Milton Sanitary Sewer Rehab & Lift Station Contract #2— 60% Complete**
  - a. Install approx. 7500LF of 12 & 15” Gravity Sewer, 3 Bores, 1 Lift Station
  - b. Owner: Milton Utility Commission, Tom Canterbury, 304-743-3422
  - c. Contract Amount: \$5,063,645.00
  - d. Engineer: Thrasher Group, Eric Sherrard, 304-343-7601
  - e. Anticipated Completion: August 2023
  
- 4) Milton Sanitary Sewer Rehab Contract #3 – 75% Complete**
  - a. Install approx. 8,000LF of 4 & 6” Force Main, 3,500LF of 8” Gravity Sewer, 2 New Pump Station and Rehab 3 Pump Stations
  - b. Owner: Milton Utility Commission, Tom Canterbury, 304-743-3422
  - c. Contract Amount: \$3,203,225.00
  - d. Engineer: Thrasher Group, Eric Sherrard, 304-343-7601
  - e. Anticipated Completion: July 2023

- 5) **Newtonsville Collection System Part B—95% Complete**
  - a. Install approx. 16,000LF of 8” Sanitary Sewer, 4,000LF Service Line, 1 Pump Station
  - b. Owner: Clermont County Commissioners, 513-732-7300
  - c. Contract Amount: \$6,009,146.00
  - d. Engineer: Jacobs Engineering, 513-595-7500
  - e. Anticipated Completion: June 2023
  
- 6) **Parkersburg Large Diameter Water Main Replacement – 85% Complete**
  - a. Install Approx 28,600LF of 12” Water Main, 4,400LF of 6-8”, 1 Booster Station
  - b. Owner: Parkersburg Utility Board, Eric Bennett, 304-424-8535
  - c. Contract Amount: \$8,400,184.00
  - d. Engineer: Burgess & Niple, Tim Utt, 304-485-8573
  - e. Anticipated Completion: June 2023
  
- 7) **Richwood- Hinkle Mountain & Little Laurel Water Extension – 85% Complete**
  - a. Install approx. 8,500LF of 6-8” Water Line
  - b. Owner: City of Richwood, 304-846-2596
  - c. Contract Amount: \$5,157,136.00
  - d. Engineer: Thompson & Litton, Matt Peters, 304-425-9555
  - e. Anticipated Completion: August 2023
  
- 8) **Lavalette PSD Water Improvements Project- Under Contract**
  - a. Install approx. 27,750LF of 8” Water Line
  - b. Owner: Lavalette PSD, Richard Smith, 304-525-3771
  - c. Contract Amount: \$2,711,406.00
  - d. Engineer: EL Robinson, Mark McGettigan, 304-993-7679
  - e. Anticipated Completion: February 2024
  
- 9) **Town of Ceredo- 6<sup>th</sup> Street Sanitary Sewer Improvements- 95% Complete**
  - a. Install approx. 750LF of 8” PVC SDR35 gravity sanitary sewer
  - b. Owner: Town of Ceredo, Paul Billups,
  - c. Contract Amount: \$170,430.00
  - d. Engineer: Potesta & Associates, Terry Moran, 304-342-1400
  - e. Anticipated Completion: June 2023
  
- 10) **LFUCG East Hickman Force Main- Under Contract**
  - a. Install approx. 31,000LF of 36” force main
  - b. Owner: LFUCG, LFUCG, Contact: Bob Peterson, 859-425-2438
  - c. Contract Amount: \$19,155.655.00
  - d. Engineer: Engineer: GRW Inc., Contact: Mike Jacobs, 859-489-5319
  - e. Anticipated Completion: December 2024





2125 County Rd 1, South Point, OH 45680

**List of Projects Completed:**

- 1) **Ben Creek Water Project-** Installation of 60,000LF of 10", 6" and 2" Waterline, Booster Station, Meter Settings, 2 – PRV, Valves and Hydrants.
  - a. Contract Amount: \$3,281,274.42
  - b. Dates of Construction: 04/2015 – 01/2016
  - c. Owner: Mingo County PSD, Contact: JB Heflin, 304-235-2244)
  - d. Engineer: E.L Robinson, Contact: Mark McGettigan, 304-776-7473
  
- 2) **Hinton, WV Sewer Project-** Installation of 1300LF of 8" Gravity Sewer Line, 7 Manholes, Laterals and Concrete Street Restoration.
  - a. Contract Amount: \$148,743.00
  - b. Dates of Construction: 05/2015
  - c. Owner: Hinton Sanitation Board, Contact: Cris Meadows, 304-466-3255
  - d. Engineer: Thrasher Group, Contact: Ted Hamb, 800-273-6541
  
- 3) **Wilderness Water Project-** Installation of 1 Booster Station, 11,000LF of 8" and 6" Waterline, Water Meter Setting, Valves and Hydrants.
  - a. Contract Amount: \$874,506.00
  - b. Dates of Construction: 08/2015 – 06/2016
  - c. Owner: Wilderness PSD, Contact: Scott Rader, 304-872-5225
  - d. Engineer: Stafford Consultants, Contact: Ed Shutt, 304-425-9555
  
- 4) **Beckley Sewer Project, Contract 11-1-** Installation of 23,000LF of 4"-18" Sewer Line and 110 Manholes
  - a. Contract Amount: \$3,238,775.00
  - b. Dates of Construction: 11/2015 – 08/2016
  - c. Owner: Beckley WV Sanitation Board, Contact: Jeremiah Johnson, 304-253-3526
  - d. Engineer: Burgess & Niple, Contact: Tim Utt, 304-485-8573
  
- 5) **St. Mary's Sewer Project-** Installation of 2400 LF of 8" and 12" Gravity Sewer Line, 1600 LF of 12"-18" Storm Sewer Line, 3300LF of 4" Gas Line, 20 Manholes and Drop Inlets
  - a. Contract Amount: \$981,400
  - b. Dates of Construction: 01/2016 – 08/2016
  - c. Owner: WV Dept. of Corrections, Contact: Phillip Farley, 304-558-2036 Ext 53463
  - d. Engineer: S&S Engineering, Contact: Jessie O. Parker Jr., 304-342-7168



- 6) Webb Tank Project-** Installation of a Retaining Wall Behind Existing Water Tank
  - a. Contract Amount: \$113,726.00
  - b. Dates of Construction: 04/2016 – 06-2016
  - c. Owner: Crum WV PSD, Contact: Jessie Allen, 304-393-3162
  - d. Engineer: E.L. Robinson, Contact: Mark McGettigan, 304-776-7473
  
- 7) Fairborn Raw Water Project-** Installation of 9600' 18" DIP Raw Waterline, 5-18" Butterfly Valves with Vaults, Chlorine Injection Vaults and Restoration.
  - a. Contract Amount: \$1,885,506.00
  - b. Dates of Construction: 05/2016 – 01/2017
  - c. Owner: Fairborn Ohio PSD, Contact: Karen Hawkins, 937-754-3097
  - d. Engineer: AECOM Columbus, OH, Contact: Brian Benedict, 614-600-5812
  
- 8) Ironton Storm/Sanitary Sewer Separation Project-** Installation of 12", 18" & 24" Storm Sewer Line, 8" Sanitary Sewer Line, Catch Basins, Manholes, Asphalt Repair, Concrete Sidewalks, Curbs, Curb Ramps & Concrete Alley Construction.
  - a. Contract Amount: \$774,088.00
  - b. Dates of Construction: 07/2016 – 04/2017
  - c. Owner: City of Ironton, Contact: Katrina Keith, 740-532-3833
  - d. Engineer: E.L. Robinson, Contact: Michael Williams, PE, 740-532-2411
  
- 9) Ironton Brick Street Repair Project-** 4,700 SQFT of Brick Roadway Surface Rehab with Concrete Base
  - a. Contract Amount: \$79,800.00
  - b. Dates of Construction: 05/2017 – 05/2017
  - c. Owner: City of Ironton, Contact: Katrina Keith, 740-532-3833
  - d. Engineer: E.L. Robinson, Contact: Michael Williams, PE, 740-532-2411
  
- 10) Malden Contract No. 2- Sewer Project-** Force Main Improvements, Install 11,000LF of 12-18" Force Main
  - a. Contract Amount: \$1,281,060.00
  - b. Dates of Construction: October 2016-August 2017
  - c. Owner: Malden PSD, Charleston, WV; Contact: Chet Adkins, 304-925-6997
  - d. Engineer: Thrasher Group; Contact: Jesse Alden, 304-343-7601
  
- 11) Malden Contract No. 4- Sewer Project-** Install Effluent Discharge Line, 3,300LF of 30" PVC Gravity Discharge Line
  - a. Contract Amount: \$773,965.00
  - b. Dates of Construction: October 2016-July 2017
  - c. Owner: Malden PSD, Charleston, WV; Contact: Chet Adkins, 304-925-6997
  - d. Engineer: Thrasher Group; Contact: Jesse Alden, 304-343-7601

**12) UK Trunk A Sanitary Sewer Project-** Install 2200LF 42" Sanitary Sewer & 400LF 36" CIPP Lining, 26 Manholes and Concrete and Asphalt Road Restoration

- a. Contract Amount: \$2,767,032.00
- b. Dates of Construction: 09/2016 – 09/2017
- c. Owner: LFUCG, Lexington, KY; Contact: Vernon Azevedo, 859-425-2438
- d. Engineer: MSE of Kentucky; Contact: Glen Ross, 859-223-5694

**13) Ironton Floodwall Pump Station #6 Outfall Relining-** Install 400 LF of 48" Slip lining and Installation of One Sluice Gate Vault

- a. Contract Amount: \$671,036.00
- b. Dates of Construction: 07/2017 – 09/2017
- c. Owner: City of Ironton, Contact: Katrina Keith, 740-532-3833
- d. Engineer: E.L Robinson, Contact: Michael Williams, PE, 740-532-2411

**14) Arthur Plat Water Project-** Install 12,000LF of 8" DIP Waterline, 304 Water Services

- a. Owner: Montgomery County, Ohio Board of Commissioners, Contact: Ed Schlaack, 937-781-2632
- b. Dates of Construction: 08/2017 – 06/2018
- c. Contract Amount: \$1,674,968.00
- d. Engineer: Northwest Consultants, Inc., Contact: Tom Lyons, 937-291-9092

**15) Hampton Manor Sanitary Sewer Improvements Project-** Install 3500LF of 24" Gravity Sewer Line and 38 Manholes

- a. Owner: WMU, Contact: Eddie Hightower, 859-744-5434
- b. Dates of Construction: 06/2017 – 05/2018
- c. Contract Amount: \$1,250,700.00
- d. Engineer: Palmer Engineering Inc, Contact: Stephanie Blain 859-714-1218

**16) W16-4 NW Regional to E Regional System Interconnection-** Install 5,100LF of 20" DIP Water Main

- a. Owner: Greene County, Ohio, Contact: Randy Gilbert, 937-562-7499
- b. Dates of Construction: 12/2017 – 04/2018
- c. Contract Amount: \$1,220,906.48
- d. Engineer: Greene County, Contact: Randy Gilbert, 937-562-7499

**17) West Hickman B&C- Sewer Project-** Install 7,300LF of 48-60" Gravity Sewer and Manholes

- a. Owner: LFUCG, Lexington, KY; Contact: Vernon Azevedo, 859-425-2438
- b. Dates of Construction: 04/2017 – 06/2018
- c. Contract Amount: \$5,890,949.00
- d. Engineer: Vision Engineering, Contact: Jihad Hallany, 859-559-0516

**18) City of Ashland 29<sup>th</sup> St. Storm Water Separation Project-** Install 6,875 LF of 15"-48"

Diameter Storm Line and Manholes

- a. Owner: City of Ashland, Contact: Ryan Eastwood PE, 606-327-2008
- b. Dates of Construction: 04/2017 – 09/2018
- c. Contract Amount: \$2,941,565.00
- d. Engineer: HDR Engineering Inc, Contact: 859-223-3755

**19) Greenbrier PSD – Sewer Extension Phase A, Contract 2 Houfnagle Rd-** Install 9,000LF of 8" and 6" Gravity Sewer and Manholes

- a. Owner: Greenbrier PSD #1, Contact: Lisa Bennett, 304-645-6632
- b. Dates of Construction: 03/2018 – 10/2018
- c. Contract Amount: \$1,449,174.00
- d. Engineer: Criss Haynes, PE, 304-667-9507

**20) Danese PSD AML Water Project Contract #1-** Install 62,000LF of 6" and 4" Water Line

- a. Owner: Danese, WV PSD, Contact: Cynthia Jones: 304-438-6686
- b. Dates of Construction: 01/2018 – 12/2018
- c. Contract Amount: \$2,250,991.00
- d. Engineer: E.L Robinson, Contact: Ray Tilly, 304-252-7473

**21) Danese PSD AML Water Project Contract #3-** Install 20,000LF of 2-6" Water Line

- a. Owner: Danese, WV PSD, Contact: Cynthia Jones: 304-438-6686
- b. Dates of Construction: 02/2018 – 12/2018
- c. Contract Amount: \$719,316.00
- d. Engineer: E.L Robinson, Contact: Ray Tilly, 304-252-7473

**22) Island Creek Sanitary Sewer Extension Project-** Install 6,500LF of 16" DIP Gravity Sewer Line, 8,400LC of 8" Gravity Sewer and 105 Manholes

- a. Owner: Logan, WV PSD, Contact: William Baisden, 304-946-2641
- b. Dates of Construction: 01/2018 – 12/2018
- c. Contract Amount: \$4,675,776.00
- d. Engineer: E.L Robinson, Contact: Rick Roberts, 304-776-7473

**23) Maysville Sewer Line Extension Project-** Install 16,000LF of 8" Force Main, 9,200LF of 6&8" Gravity Sewer, 1 Lift Station

- a. Owner: City of Maysville, KY, Contact: David Cartmell, 606-564-9419
- b. Dates of Construction: 03/2018 – 10/2018
- c. Contract Amount: \$1,494,192.00
- d. Engineer: Tetra Tech, Inc., Contact: Herbert LeMaster, 859-223-8000

**24) Williamsdale Sanitary Sewer Expansion Project-** Install 3,300LF of 8-15" SDR 35&26 Pipe and 21 Manholes

- a. Owner: Butler County Ohio, Contact: Wayne Beyerline, 513- 867-5744
- b. Dates of Construction: 06/2018 – 12/2018
- c. Contract Amount: \$1,102,261.00
- d. Engineer: Same as Owner

**25) South Point Clarifier Rehabilitation Project-** Installation of 4 clarifiers for the Village of South Point Sewer Plant

- a. Owner: Village of South Point; Contact: Russ McDonald, 740-377-2304
- b. Dates of Construction: 01/2018 – 12/2018
- c. Contract Amount: \$721,394.00
- d. Engineer: E.L Robinson, Contact: Michael Williams, PE, 740-532-2411

**26) Glenss Creek Interceptor-** Dig & Replace 8,300LF of 24-36" Sanitary Sewer

- a. Owner: City of Frankfort, KY, Contact: Elizabeth Coyle, 502-875-2448
- b. Dates of Construction: 07/2018 – 06/2019
- c. Contract Amount: \$2,282,242.00
- d. Engineer: Hazen & Sawyer, Contact: Kurt Zehnder, 859-317-1424

**27) Summit Rd to Cable Rd Water Line Improvements-** Install 18,000LF of 12" & 8" PVC Waterline

- a. Owner: SWLCWSD, Contact: Lee Conkel, 740-927-0410
- b. Dates of Construction: 08/2018 – 06/2019
- c. Contract Amount: \$1,517,771.00
- d. Engineer: Same as Owner

**28) Hebron Area Sanitary Sewer Improvements Project-** Install 7,000LF of 16" PVC Force Main, 12MH's and 2,500LF of 30" Dig and Replace Gravity Sewer

- a. Owner: Sanitation District #1, Contact: Mike Glowacki, 859-547-1646
- b. Dates of Construction: 05/2018 – 06/2019
- c. Contract Amount: \$2,472,397.00
- d. Engineer: GRW Engineers, Contact: Spencer Stork, 859-223-3999

**29) Town Branch Commons Sanitary Sewer Project-** Installation of 4,800LF of 12-24" PVC Sanitary Sewer Line

- a. Owner: LFUCG Lexington, KY, Contact: Bob Peterson, 859-425-2255
- b. Dates of Construction: 07/2018 – 07/2019
- c. Contract Amount: \$6,412,416.00
- d. Engineer: Strand Associates, Contact: Mike Davis, 859-225-8500

**30) Sam Black Church Waterline Extension Contract 1-** Installation of 7,500LF of 2-8" Water Line

- a. Owner: Greenbrier PSD #2, Contact: Kevin Williams, 304-667-1749
- b. Dates of Construction: 09/2018 – 09/2019
- c. Contract Amount: \$3,500,331.00
- d. Engineer: Thrasher Group, Contact: Thomas Morgan, 304-624-4108

- 31) Big Harts Phase 3 Waterline Extension Project**– Installation of 29,000 LF of 2-8” Water Line
- Owner: Logan, WV PSD, Contact: William Baisden, 304-946-2641
  - Dates of Construction: 09/2019 – 08/2019
  - Contract Amount: \$1,705,644.00
  - Engineer: E.L Robinson, Contact: Rick Roberts, 304-776-7473
- 32) AQUA Ohio, Lawrence County Group 2 Water Improvements**- Installation of 2,400LF of 6 & 8” Water Line with 53 services
- Owner: AQUA Ohio, Contact: Richard Dunham, 440-725-2390
  - Dates of Construction: 07/2019 – 09/2019
  - Contract Amount: \$438,000.00
  - Engineer: Same as Owner
- 33) Burlington Sewer Force Main Upgrade**- Installation of 4,500LF of 24” Ductile Iron Force Main
- Owner: Sanitation District #1, Contact: Mike Glowacki, 859-547-1646
  - Dates of Construction: 04/2019 – 09/2019
  - Contract Amount: \$1,433,560.00
  - Engineer: HDR Engineering Inc, Contact: 859-223-3755
- 34) Union PSD Rocky Fork Sanitary Sewer Extension Contract 1**- Installation of 25,000LF of Gravity Sewer and 3 Pump Stations
- Owner: Union, WV PSD, Contact: Earl Burks, 304-776-3131
  - Dates of Construction: 12/2018 – 01/2020
  - Contract Amount: \$4,105,000.00
  - Engineer: Thrasher Group, Contact: Jesse Alden, 304-343-7601
- 35) Union PSD 40<sup>th</sup> St Sanitary Sewer Extension Contract 2**- Installation of 3,500LF of 6” and 8” Gravity Sewer
- Owner: Union, WV PSD, Contact: Earl Burks, 304-776-3131
  - Dates of Construction: 12/2018 – 01/2020
  - Contract Amount: \$691,150.00
  - Engineer: Thrasher Group, Contact: Jesse Alden, 304-343-7601
- 36) Union PSD Koontz Drive Lift Station Contract 3**- Installation of 1,400LF of 6” Force Main and Lift Station
- Owner: Union, WV PSD, Contact: Earl Burks, 304-776-3131
  - Dates of Construction: 12/2018 – 01/2020
  - Contract Amount: \$446,720.00
  - Engineer: Thrasher Group, Contact: Jesse Alden, 304-343-7601

- 37) New Richmond Water Line-** Installation of 7,000LF of 8", 7,500LF of 6" & 4,400LF of 2" Water Line
- Owner: Ravenscliff-McGraws PSD; Contact: 304-682-0211
  - Dates of Construction: 05/2019 – 01/2020
  - Contract Amount: \$1,599,088.00
  - Engineer: Thrasher Group, Contact: Michael Stone, 304-431-7800
- 38) Big Harts Phase 4 Waterline Extension Project-** Installation of 41,000LF of 2-8" Waterline
- Owner: Logan, WV PSD, Contact: William Baisden, 304-946-2641
  - Dates of Construction: 04/2019 – 01/2020
  - Contract Amount: \$2,548,744.50
  - Engineer: E.L Robinson, Contact: Rick Roberts, 304-776-7473
- 39) Cox Road and Oliver Road 12" Water Main Replacement-** Installation of 7,500LF of 12" Ductile Iron Water Main
- Owner: Northern KY Water District, Contact: Steve Broering, 859-426-2728
  - Dates of Construction: 03/2019 – 04/2020
  - Contract Amount: \$940,926.60
  - Engineer: Same as Owner
- 40) National Pike Little Farms Water Main Replacement Phase 1-** Installation of 18,000LF of 6 & 8" Water Main, 335 Services
- Owner: Franklin County Commissioners, Contact: Ryan Stowe, 614-374-5897
  - Dates of Construction: 10/2019 – 07/2020
  - Contract Amount: \$5,056,620.32
  - Engineer: CCI, Contact: Roger Jacobson, 614-485-0670
- 41) Park Pointe Force Main Bypass Project-** Directional Drill Installation of 280LF of 14: HDPE & Two Tie-ins
- Owner: Huntington Sanitary Board, Contact: Wes Leek, 304-696-4437
  - Dates of Construction: August 2020
  - Contract Amount: \$102,000.00
  - Engineer: Potesta & Associates, Contact: Pat Taylor, 304-342-1400
- 42) 5<sup>th</sup> Ave Outfall Inline Check Valve Project-**Install Inline Check Valve Into 60" Concrete CSO Outfall Pipe
- Owner: Huntington Sanitary Board, Contact: Wes Leek, 304-696-4437
  - Dates of Construction: August 2020
  - Contract Amount: \$71,200.00
  - Engineer: Potesta & Associates, Contact: Pat Taylor, 304-342-1400
- 43) Wolf Run Trunk B&C Sewer Project-** Installation of 4,700LF 42-36" Sanitary Sewer
- Owner: LFUCG, Contact: Bob Peterson, 859-425-2438
  - Dates of Construction: 04/2019 – 10/2020
  - Contract Amount: \$6,253,480.00
  - Engineer: Kenvirons, Contact: Phil Meador, 502-695-4357

- 44) Shady Spring Pluto/Fire Trail Rd Sewer Extension Contract 1-** Installation of 25,000LF of 6-8" Gravity Sewer & Pump Stations
- Owner: Shady Spring PSD, Contact: Jerry Smith, 304-255-1565
  - Dates of Construction: 04/2019 – 11/2020
  - Contract Amount: \$4,418,670.77
  - Engineer: Cardno, Contact: Myron Amick, 304-809-0606
- 45) Shady Spring Pluto/Fire Trail Rd Sewer Extension Contract 2-** Installation 18,000LF of 2-4" Force Main, 64 Grinders and a Pump Station
- Owner: Shady Spring PSD, Contact: Jerry Smith, 304-255-1565
  - Dates of Construction: 04/2019 – 11/2020
  - Contract Amount: \$2,449,416.82
  - Engineer: Cardno, Contact: Myron Amick, 304-809-0606
- 46) Giatto-Weyanoke Waterline Extension Contract 3-** Installation of 16,000LF of 8" and 2,300LF of 2" Waterline
- Owner: Lashmeet PSD, Contact: Robin McGraw, 304-682-0211
  - Dates of Construction: 03/2020 – 12/2020
  - Contract Amount: \$1,560,431.80
  - Engineer: Thompson & Litton, Contact: Stacy Fowler, 304-425-9555
- 47) West Dunbar Sanitary Sewer Improvements Contract 1-** Installation of 15,000LF of 6-10" Gravity Sewer & 94 MH's
- Owner: West Dunbar PSD, Contact: Dr. John Fuller, 304-766-0220
  - Dates of Construction: 01/2020 – 03/2021
  - Contract Amount: \$5,545,159.69
  - Engineer: Gosh Engineers, Contact: Kennon Chambers, 304-343-5300
- 48) Ashland Simpson Road Water Line Replacement –** Installation of 3,300LF of 16" DR Water Line Replacement
- Owner: City of Ashland, Contact: Steve Cole, 606-385-3332
  - Dates of Construction: 08/2020 – 04/2021
  - Contract Amount: \$665,498.00
  - Engineer: Same as Owner
- 49) Huntington 8<sup>th</sup> & 10<sup>th</sup> St Pump Stations-** Installation of Two Stormwater Pump Stations & 800LF of 16" Force Main
- Owner: Huntington Sanitary Board, Contact: Wes Leek, 304-696-4437
  - Dates of Construction: 06/2020—06/2021
  - Contract Amount: \$1,099,410.00
  - Engineer: Potesta & Associates, Contact: Pat Taylor, 304-342-1400

**50) CSB Woodward Branch Sanitary Sewer Improvements Phase I**—Installation of 15,000 LF of 6-18" Gravity Sewer, 109 MHs, 156 House Service Cleanouts, Etc

- a. Owner: Charleston Sanitary Board, Contact: Tim Haapala, 304-348-1084
- b. Dates of Construction: 05/2020—07/2021
- c. Contract Amount: \$5,144,375.00
- d. Engineer: Burgess & Niple, Contact: Craig Richards, 304-485-8541

**51) US 27/AA Highway Sanitary Sewer Improvements Riley Road**- Installation of 6,900LF of 15-21" Gravity Sewer, 11 MH's, 11 MH Modifications, 1 Bore and Jack

- a. Owner: SD1, Contact: Spencer Stork, 859-578-6894
- b. Dates of Construction: 01/2021—05/2021
- c. Contract Amount: \$1,527,015.52
- d. Engineer: AECOM, Contact: Brian Shmude, 614-600-5990

**52) Elkhorn Creek Water Project Phase II Contract 1**— Installation of 70,000LF of 2-10" Water Line

- a. Owner: McDowell Co PSD, Contact: Mavis Brewster, 304-297-2622
- b. Dates of Construction: 01/2021 – 01/2021
- c. Contract Amount: \$5,106,715.00
- d. Engineer: E.L Robinson, Contact: Ray Tilly, 304-252-7473

**53) Lexington Woods Booster Station Contract 1-2020**—Installation of a booster station and 300LF of 16" Water Line

- a. Owner: SWLCWSD, Contact: Chris Gilcher, 740-927-4100
- b. Dates of Construction: 04/2021 –11/2021
- c. Contract Amount: \$979,394.00
- d. Engineer: Strand Associates, Contact: Patrick Karnes, 614-835-0460

**54) CSB Danner Hollow Sanitary Sewer Improvements**—Installation of 5,000LF of 6-12" Gravity Sewer and 52 MH's

- a. Owner: Charleston Sanitary Board, Contact: Tim Haapala, 304-348-1084
- b. Dates of Construction: April 2021 – October 2021
- c. Contract Amount: \$2,279,384
- d. Engineer: Burgess & Niple, Contact: Craig Richards, 304-485-8541

**55) LEDC- Industrial Corridor Pump Station Force Main**- Installation of 31,000LF of 8" Force Main, 5,650LF of 12" Gravity Sewer, 26 MHs and 1 Lift Station

- a. Owner: LEDC: Jeremy Clay, 740-377-4550
- b. Dates of Construction: 04/2021 – 12/2021
- c. Contract Amount: \$4,050,297.00
- d. Engineer: Strand Associates: Contact Nina Durek, 614-835-0460



**56) James E Sauls Dr. Water Line Project**—Installation of 8,500LF of 18" Water Line

- a. Owner: Clermont County, Contact Matt Sanders, 513-732-8882
- b. Dates of Construction: 09/2021 – 12/2021
- c. Contract Amount: \$1,261,166.00
- d. Engineer: Clermont County, Contact Matt Sanders, 513-732-8882

**57) Village of South Point- Waterline Improvements Project Phase 1-** Install 7,000LF of 2-8" PVC Waterline and approx. 80 House Services, 2 RR Bores

- a. Owner: Village of South Point: Russ McDonald, 740-377-2304
- b. Dates of Construction: 07/2021 / 12/2021
- c. Contract Amount: \$916,247.00
- d. Engineer: IBI Group: Jack Christy 614-818-4900

**58) Culloden Wastewater System Improvements Contract #1-** Install 7,500LF of 6-15" Gravity Sewer, 1 Pump Station

- a. Owner: Culloden PSD, Contact: Nathan Johnson 304-416-0576
- b. Dates of Construction: 02/2020 – 06/2022
- c. Contract Amount: \$1,483,136.00
- d. Engineer: Chapman Technical, Contact: Matt Tanner, 304-727-5501

**59) Center PSD Pineville Existing Collection System Replacement**—Dig & Replace 5,280LF of 8-15" Gravity Sewer

- a. Owner: Center PSD, Contact: Bryan Alred, 304-558-2981
- b. Dates of Construction: 01/2021—05/2022
- c. Contract Amount: \$2,146,150.00
- d. Engineer: Thompson & Litton, Contact: Stacy Fowler, 304-425-9555

**60) LFUCG Wolf Run Trunk D&E Sewer Project-** Install 7,500LF of 8-36" Gravity Sewer, Trunk Sewer Replacement, 52 MH's

- a. Owner: LFUCG, Contact: Bob Peterson, 859-425-2438
- b. Dates of Construction: 04/2021 – 07/2022
- c. Contract Amount: \$3,021,087.00
- d. Engineer: GRW Inc., Contact: Mike Jacobs, 859-489-5319
- e. Anticipated Completion: August 2022

**61) LFUCG- Southeastern Hills Trunk Sewer Improvements**—Install 2500LF 18-24" Gravity Sewer, 2035LF 18" Pipe Bursting, 1 Bore, 32MHs

- a. Owner: LFUCG, Contact: Bob Peterson, 859-425-2438
- b. Dates of Construction: 08/2021 – 09/2022
- c. Contract Amount: \$3,582,778.00
- d. Engineer: Strand Associates, Contact: Mike Davis, 859-225-850
- e. Anticipated Completion: August 2022

**62) CSB Woodward Branch Sanitary Sewer Improvements Phase II—15,000LF of 6-10” Gravity Sewer and 150 MH’s**

- a. Owner: Charleston Sanitary Board, Contact: Tim Haapala, 304-348-1084
- b. Dates of Construction: 11/2021 – 08/2022
- c. Contract Amount: \$4,687,974.00
- d. Engineer: Burgess & Niple, Contact: Craig Richards, 304-485-8541
- e. Anticipated Completion: July 2022

**63) Village of Middleport Water System Improvements—Install approx. 15,000LF of 4-10” Water Line, Service Meters**

- a. Owner: Village of Middleport, Joe Woodall, 740 992-6424
- b. Dates of Construction: 09/2021 – 06/2022
- c. Contract Amount: \$3,479,434.00
- d. Engineer: Choice One Engineering, Brian Schmidt, 419.305.2551

**64) City of Pennsboro Water System Improvements Project –Install approx. 23,000LF of 2-8” Water Line, 200 Service Settings, Water Storage Tank Rehabilitation**

- a. Owner: City of Pennsboro, Robert Riggs, 304-659-2377
- b. Dates of Construction: 10/2021 – 08/2022
- c. Contract Amount: \$3,019,633.00
- d. Engineer: Thrasher Group, Steve Haynes, 304-624-4108

**65) Village of South Point- Waterline Improvements Project Phase 2- Install 12,500LF of 8” PVC Waterline and approx. 150 House Services**

- a. Owner: Village of South Point: Russ McDonald, 740-377-2304
- b. Dates of Construction: 02/2022 – 09/2022
- c. Contract Amount: \$1,442,523.50
- d. Engineer: IBI Group: Jack Christy 614-818-4900

**66) Lewisburg Contract 8A Raw Water Line- Install approx. 12,000LF of 24” DI Water Line**

- a. Owner: City of Lewisburg, Beverly White
- b. Dates of Construction: 09/2022 – 03/2023
- c. Contract Amount: \$4,369,818.60
- d. Engineer: Chapman Technical Group, Michael Stone, 304-727-5501

**67) Yeager Airport/ Eagle Mountain Road Sewer Extension- Install approx. 3,000 of 8” gravity sewer, 15 MHs**

- a. Owner: WV Airport Authority, Kevin Price, 304-344-8033
- b. Dates of Construction: 01/2023- 03/2023
- c. Contract Amount:
- d. Engineer: TranSystems Engineering, Melissa Defibaugh, 304-481-6136

Commonwealth of Kentucky  
Alison Lundergan Grimes, Secretary of State

L906  
0916193  
Alison Lundergan Grimes  
KY Secretary of State  
Received and Filed  
4/27/2017 8:51:11 AM  
Fee receipt: \$10.00

Alison Lundergan Grimes  
Secretary of State  
P. O. Box 718  
Frankfort, KY 40602-0718  
(502) 564-3490  
<http://www.sos.ky.gov>

Statement of Change of  
Principal Office Address

POC

Pursuant to the provisions of KRS chapters 271B, 273, 275, or 362, the undersigned hereby applies to change the principal office on behalf of

**TRIBUTE CONTRACTING & CONSULTANTS LLC**

which is organized in the state of Ohio, and for that purpose submits the following statements:

**1. Address of current principal office**

306 LITTLE SOLIDA ROAD  
SOUTH POINT, OH 45680

**2. Principal office is hereby changed to:**

2125 County Road 1  
SOUTH POINT, OH 45680

**3. Signature of officer or chairman of the board**

Todd Harrah, Manager/Member <small>Signature and Title</small>
 <small>Type or print name and title</small>
4/27/2017 8:51 AM <small>Date</small>



COMMONWEALTH OF KENTUCKY  
ALISON LUNDERGAN GRIMES, SECRETARY OF STATE

0916193.06 dcornish  
ADD  
Alison Lundergan Grimes  
Kentucky Secretary of State  
Received and Filed:  
3/10/2015 1:29 PM  
Fee Receipt: \$90.00

Division of Business Filings  
Business Filings  
PO Box 718  
Frankfort, KY 40602  
(502) 564-3490  
www.sos.ky.gov

Certificate of Authority  
(Foreign Business Entity)

FBE

Pursuant to the provisions of KRS 14A and KRS 271B, 273, 274, 275, 362 and 386 the undersigned hereby applies for authority to transact business in Kentucky on behalf of the entity named below and, for that purpose, submits the following statements:

1. The entity is a:  profit corporation (KRS 271B),  nonprofit corporation (KRS 273),  professional service corporation (KRS 274),  
 business trust (KRS 386),  limited liability company (KRS 275),  professional limited liability company (KRS 275),  
 limited partnership (KRS 362).

2. The name of the entity is Tribute Contracting & Consultants LLC  
(The name must be identical to the name on record with the Secretary of State.)

3. The name of the entity to be used in Kentucky is (if applicable): \_\_\_\_\_  
(Only provide if "real name" is unavailable for use; otherwise, leave blank.)

4. The state or country under whose law the entity is organized is Ohio

5. The date of organization is November 10, 2014 and the period of duration is \_\_\_\_\_  
(If left blank, the period of duration is considered perpetual.)

6. The mailing address of the entity's principal office is  
306 Little Solida Road South Point OH 45680  
Street Address City State Zip Code

7. The street address of the entity's registered office in Kentucky is  
879 Wilson Run Road Wallingford KY 41093  
Street Address (No P.O. Box Numbers) City State Zip Code

and the name of the registered agent at that office is Fred Conn

8. The names and business addresses of the entity's representatives (secretary, officers and directors, managers, trustees or general partners):

<u>Todd A Harrah</u>	<u>306 Little Solida Road</u>	<u>South Point</u>	<u>OH</u>	<u>45680</u>
Name	Street or P.O. Box	City	State	Zip Code

9. If a professional service corporation, all the individual shareholders, not less than one half (1/2) of the directors, and all of the officers other than the secretary and treasurer are licensed in one or more states or territories of the United States or District of Columbia to render a professional service described in the statement of purposes of the corporation.

10. I certify that, as of the date of filing this application, the above-named entity validly exists under the laws of the jurisdiction of its formation.

11. If a limited partnership, it elects to be a limited liability limited partnership. Check the box if applicable:

12. This application will be effective upon filing, unless a delayed effective date and/or time is provided.  
The effective date or the delayed effective date cannot be prior to the date the application is filed. The date and/or time is \_\_\_\_\_  
(Delayed effective date and/or time)

Todd A Harrah Todd A Harrah 3/4/15  
Signature of Authorized Representative Printed Name & Title Date

I, Fred Conn, consent to serve as the registered agent on behalf of the business entity.  
Type/Print Name of Registered Agent

Fred Conn Fred Conn Registered Agent  
Signature of Registered Agent Printed Name Title Date




## AFFIDAVIT OF AUTHORITY TO SIGN

Date: 06/30/2015

Tribute Contracting & Consultants, LLC located at 2125 County Road 1 in South Point, OH 45680 does hereby certify that Todd Harrah, Manager/Member and Tom Enyart, Member of Tribute Contracting & Consultants, LLC has the authority to execute and/or sign all documents on behalf of Tribute Contracting & Consultants, LLC for any reason including, but not limited to, all bids or associated bidding documents and associated contract documents.

By affixing his signature Todd Harrah as Manager/Member and Tom Enyart as Member has unequivocal authority to bind Tribute Contracting & Consultants, LLC to any and all contractual arrangements.



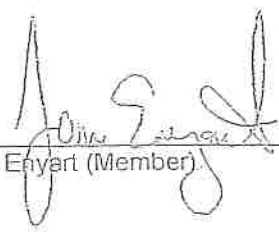
---

Todd Harrah (Manager / Member)



---

Steven D Whaley (Secretary)



---

Tom Enyart (Member)

# Certified DBE Directory

[CR and SBD Home \(/Civil-Rights-and-Small-Business-Development/Pages/default.aspx\)](#)

**Renewed Beginning July 1, 2021 through June 30, 2025** the Indiana Department of Transportation and the Kentucky Transportation Cabinet are participating in an ongoing Reciprocity agreement. DBE's certified in one state may be used for any DOT federal aid project in the partner state. Please note that DBE's will need to follow the project State's prequalification laws. For the most up to date list of DBE's certified in Indiana please click here: <https://entapps.indot.in.gov/DBELocator/> (<https://entapps.indot.in.gov/DBELocator/>)

NOTE- there are three search options: 1) by Firm, 2) by NAICS Description, or 3) the Search field, which will search for anything entered.

Example: a search for *prequalified* will return all prequalified DBEs.

[View DBE Directory](#)

A D E CONTRACTING, INC.

237990 - Other Heavy and Civil Engineering Construction

▼   
▼

[Back To Directory](#)

*not quoting*

**A D E CONTRACTING, INC.**

Ms. Angela English, President 1044 Duncan  
Road Lawrenceburg KY 40342 (859) 621-7941  
or (859) 879-0164 Fax: (502) 839-3224  
ADEINC1@aol.com

**NAICS ID**

**NAICS**

[237110](#)

Water and Sewer Line and Related Structures Construction

[237310](#)

Highway, Street, and Bridge Construction

[238910](#)

Site Preparation Contractors

## **Department of Highways**

[Construction \(/Construction/Pages/default.aspx\)](#)  
[Construction Procurement \(/Construction-Procurement/Pages/default.aspx\)](#)  
[Equipment \(/Equipment/Pages/default.aspx\)](#)  
[Environmental Analysis \(/EnvironmentalAnalysis/Pages/default.aspx\)](#)  
[Highway Design \(/Highway-Design/Pages/default.aspx\)](#)  
[Highway Safety \(/HighwaySafety/Pages/default.aspx\)](#)  
[Maintenance \(/Maintenance/Pages/default.aspx\)](#)  
[Materials \(/Materials/Pages/default.aspx\)](#)  
[Planning \(/Planning/Pages/default.aspx\)](#)  
[Professional Services \(/ProfessionalServices/Pages/default.aspx\)](#)  
[Program Management \(/Program-Management/Pages/default.aspx\)](#)  
[Right of Way & Utilities \(/RightofWay/Pages/default.aspx\)](#)  
[Structural Design \(/StructuralDesign/Pages/default.aspx\)](#)  
[Traffic Operations \(/TrafficOperations/Pages/default.aspx\)](#)

## **Department of Aviation**

[Kentucky Department of Aviation \(/Aviation/Pages/home.aspx\)](#)  
[Airport Zoning Commission \(/Aviation/Pages/airportzoning.aspx\)](#)

## **Department of Rural and Municipal Aid**

[Local Programs \(/LocalPrograms/Pages/default.aspx\)](#)  
[Local Public Agencies \(/LPA/Pages/default.aspx\)](#)  
[Rural and Municipal Aid \(/RuralandMunicipalAid/Pages/default.aspx\)](#)

## **Department of Vehicle Regulation**

[Drive.ky.gov \(https://drive.ky.gov\)](https://drive.ky.gov)

Select Language ▼

Powered by [Google Translate \(https://translate.google.com/\)](https://translate.google.com/)

## Cabinet Offices and Services

- [Audits \(/Audits/Pages/default.aspx\)](#)
- [Budget and Fiscal Management \(/BudgetFiscalManagement/Pages/default.aspx\)](#)
- [Civil Rights and Small Business Development \(/Civil-Rights-and-Small-Business-Development/Pages/default.aspx\)](#)
- [Conference Center \(/SupportServices/Pages/Conference-Center.aspx\)](#)
- [Education \(/Education/Pages/default.aspx\)](#)
- [Human Resource Management \(/HumanResourceManagement/Pages/default.aspx\)](#)
- [Information Technology \(/InformationTechnology/Pages/default.aspx\)](#)
- [Inspector General \(/InspectorGeneral/Pages/default.aspx\)](#)
- [Legal Services \(/LegalServices/Pages/default.aspx\)](#)
- [Office of the Secretary \(/Secretary/Pages/default.aspx\)](#)
- [Public Affairs \(/PublicAffairs/Pages/default.aspx\)](#)
- [Support Services \(/SupportServices/Pages/default.aspx\)](#)
- [Transportation Delivery \(/TransportationDelivery/Pages/default.aspx\)](#)

## Central Office Contact

200 Merch St. Frankfort, KY

<https://www.google.com/maps/place/200+Merch+St+Frankfort+KY+40601/data=!3m1!1e3!3m1!1s0x884274b461372dc90:803455591426ab008a23d38948735582>

✉ [Contact Form \(https://bpm.kytc.ky.gov/appbuilder/forms?code=816A805056A21477117737388D5BE87C6&Process=PA\\_DV-ContactUs\)](https://bpm.kytc.ky.gov/appbuilder/forms?code=816A805056A21477117737388D5BE87C6&Process=PA_DV-ContactUs)

☎ (502) 564-4890

📍 [Transportation.ky.gov \(https://prod16-transportation.ky.gov/\)](https://prod16-transportation.ky.gov/)

## Follow Us

📘 <https://www.facebook.com/kytc120/>, 🐦 <https://twitter.com/KYTC>, 📺 <https://www.youtube.com/user/KYTransportation>, 📷 <https://www.instagram.com/kytransportation/>

[Contact Us \(/Pages/ContactUs.aspx\)](#) [Drive.ky.gov \(https://drive.ky.gov\)](https://drive.ky.gov)

[Policies \(https://kentucky.gov/policies/Pages/default.aspx\)](https://kentucky.gov/policies/Pages/default.aspx) [Security \(https://kentucky.gov/policies/Pages/security.aspx\)](https://kentucky.gov/policies/Pages/security.aspx)

[Disclaimer \(https://kentucky.gov/policies/Pages/disclaimer.aspx\)](https://kentucky.gov/policies/Pages/disclaimer.aspx) [Accessibility \(https://kentucky.gov/policies/Pages/accessibility.aspx\)](https://kentucky.gov/policies/Pages/accessibility.aspx)



© 2020 Commonwealth of Kentucky. All rights reserved.

[Kentucky.gov \(http://www.kentucky.gov\)](http://www.kentucky.gov)



# Certified DBE Directory

[CR and SBD Home \(/Civil-Rights-and-Small-Business-Development/Pages/default.aspx\)](#)

**Renewed Beginning July 1, 2021 through June 30, 2025** the Indiana Department of Transportation and the Kentucky Transportation

Cabinet are participating in a ongoing Reciprocity agreement. DBE's certified in one state may be used for any DOT federal aid project in the partner state. Please note that DBE's will need to follow the project State's prequalification laws. For the most up to date list of DBE's certified in Indiana please click here:

<https://entapps.indot.in.gov/DBELocator/> (<https://entapps.indot.in.gov/DBELocator/>)

NOTE- there are three search options: 1) by Firm, 2) by NAICS Description, or 3) the Search field, which will search for anything entered.

Example: a search for **prequalified** will return all prequalified DBEs.

[View DBE Directory](#)

AGRADE CONSTRUCTION, INC.

237990 - Other Heavy and Civil Engineering Construction

▼   
▼

[Back To Directory](#)

## AGRADE CONSTRUCTION, INC.

Ms. Mary Anne Belcher, President PO Box  
1227 Elkhorn City KY 41522 (606) 369-5044 or  
(606) 754-8548 Fax: (606) 754-5775  
agradeconstruct@gmail.com

*not  
quoting*

### NAICS ID

[237110](#)  
[237310](#)  
[238910](#)  
[561990](#)

### NAICS

Water and Sewer Line and Related Structures Construction  
Highway, Street, and Bridge Construction  
Site Preparation Contractors  
All Other Support Services

## **Department of Highways**

[Construction \(/Construction/Pages/default.aspx\)](#)  
[Construction Procurement \(/Construction-Procurement/Pages/default.aspx\)](#)  
[Equipment \(/Equipment/Pages/default.aspx\)](#)  
[Environmental Analysis \(/EnvironmentalAnalysis/Pages/default.aspx\)](#)  
[Highway Design \(/Highway-Design/Pages/default.aspx\)](#)  
[Highway Safety \(/HighwaySafety/Pages/default.aspx\)](#)  
[Maintenance \(/Maintenance/Pages/default.aspx\)](#)  
[Materials \(/Materials/Pages/default.aspx\)](#)  
[Planning \(/Planning/Pages/default.aspx\)](#)  
[Professional Services \(/ProfessionalServices/Pages/default.aspx\)](#)  
[Program Management \(/Program-Management/Pages/default.aspx\)](#)  
[Right of Way & Utilities \(/RightofWay/Pages/default.aspx\)](#)  
[Structural Design \(/StructuralDesign/Pages/default.aspx\)](#)  
[Traffic Operations \(/TrafficOperations/Pages/default.aspx\)](#)

## **Department of Aviation**

[Kentucky Department of Aviation \(/Aviation/Pages/home.aspx\)](#)  
[Airport Zoning Commission \(/Aviation/Pages/airportzoning.aspx\)](#)

## **Department of Rural and Municipal Aid**

[Local Programs \(/LocalPrograms/Pages/default.aspx\)](#)  
[Local Public Agencies \(/LPA/Pages/default.aspx\)](#)  
[Rural and Municipal Aid \(/RuralandMunicipalAid/Pages/default.aspx\)](#)

## **Department of Vehicle Regulation**

[Drive.ky.gov \(https://drive.ky.gov\)](https://drive.ky.gov)

Select Language ▼

Powered by [Google Translate \(https://translate.google.com/\)](https://translate.google.com/)

## Cabinet Offices and Services

- [Audits \(/Audits/Pages/default.aspx\)](#)
- [Budget and Fiscal Management \(/BudgetFiscalManagement/Pages/default.aspx\)](#)
- [Civil Rights and Small Business Development \(/Civil-Rights-and-Small-Business-Development/Pages/default.aspx\)](#)
- [Conference Center \(/SupportServices/Pages/Conference-Center.aspx\)](#)
- [Education \(/Education/Pages/default.aspx\)](#)
- [Human Resource Management \(/HumanResourceManagement/Pages/default.aspx\)](#)
- [Information Technology \(/InformationTechnology/Pages/default.aspx\)](#)
- [Inspector General \(/InspectorGeneral/Pages/default.aspx\)](#)
- [Legal Services \(/LegalServices/Pages/default.aspx\)](#)
- [Office of the Secretary \(/Secretary/Pages/default.aspx\)](#)
- [Public Affairs \(/PublicAffairs/Pages/default.aspx\)](#)
- [Support Services \(/SupportServices/Pages/default.aspx\)](#)
- [Transportation Delivery \(/TransportationDelivery/Pages/default.aspx\)](#)

## Central Office Contact

200 Meri St. Frankfort, KY

<https://www.google.com/maps/place/200+Meri+St,+Frankfort,+KY+40601/@38.201597,-84.8757469,17z/data=!3m1!1e1!3m1!1s0x8834274b5461372dc9:016054553914201b90f0m2!3d38.848735582>

[Contact Form \(https://bpis.kytc.ky.gov/appbuilder/forms?LooB=8110A805056A2:47711773738BD5BF87C&Process=PA-DV-Contacts\)](https://bpis.kytc.ky.gov/appbuilder/forms?LooB=8110A805056A2:47711773738BD5BF87C&Process=PA-DV-Contacts)

**(502) 564-4890**

[Transportation.ky.gov \(https://prod16.transportation.ky.gov/\)](https://prod16.transportation.ky.gov/)

## Follow Us

[Facebook \(https://www.facebook.com/kytc120/\)](https://www.facebook.com/kytc120/) [Twitter \(https://twitter.com/KYTC\)](https://twitter.com/KYTC) [YouTube \(https://www.youtube.com/user/KYTransportation\)](https://www.youtube.com/user/KYTransportation) [Instagram \(https://www.instagram.com/kytransportation/\)](https://www.instagram.com/kytransportation/)

[Contact Us \(/Pages/ContactUs.aspx\)](#) [Drive.ky.gov \(https://drive.ky.gov\)](https://drive.ky.gov)

[Policies \(https://kentucky.gov/policies/Pages/default.aspx\)](https://kentucky.gov/policies/Pages/default.aspx) [Security \(https://kentucky.gov/policies/Pages/security.aspx\)](https://kentucky.gov/policies/Pages/security.aspx)

[Disclaimer \(https://kentucky.gov/policies/Pages/disclaimer.aspx\)](https://kentucky.gov/policies/Pages/disclaimer.aspx) [Accessibility \(https://kentucky.gov/policies/Pages/accessibility.aspx\)](https://kentucky.gov/policies/Pages/accessibility.aspx)



© 2020 Commonwealth of Kentucky. All rights reserved.

[Kentucky.gov \(http://www.kentucky.gov\)](http://www.kentucky.gov)

# LFUGG MWDBE Directory From Sherita Miller

**Company Name**      **Business Product or Service**      **Contact Phone**      **First Name**      **Last Name**      **Email**

*no paving or pre-con video*

360Water Inc.	Web-based Courseware, Professional and Consulting Services	614-294-3600	Laura Tegeth Raish	Laura T	LauraT@360water.com
7pm Group, LLC	Building Maintenance Materials: Electrical and Plumbing	502-417-4249	Vincent	Anthony	vanthony@7pmgroup.com
Abbie Jones Consulting	Civil Engineering: Land Surveying, Utility Locating, Traffic	859-559-3443	Abbie Jones	Jones	abbie@abbie-jones.com
Abundant Living Psychological and Coaching Services for Children	Professional Services: Instruction, Education Training, Medication	859-229-6823	Shambra Mulder	Mulder	drshambra@abundantlivingpsych.com
Acme Supply Co., LTD.	Linens, Clothing, Personal Care Items	800-567-8025	Zaheer	Sheik	bn@acmesupply.us
ActOne Government Solutions	Professional and Consulting Services	866-493-8343	Milton	Perkins	govnotices@a1governmentalsolutions.com
ADA Inspections Nationwide, LLC	Professional and Consulting Services: Americans with Disabilities Act (ADA), Architectural Barriers Act (ABA)	615-752-0060	Richard	Acree	inspections4ada@gmail.com
Ad-Venture Promotions	Promotional Products, Wearables	859-263-4299	Cathy	Stafford	cathy@ad-venturepromotions.com
ADE Contracting, Inc.	Underground utilities, Excavation, Curb and Walk Construction	859-621-7941	Angela	English	adein@adeol.com
AGrade Construction, Inc.	Surveying & Incidental Construction	606-369-5044	Mary Anne Belcher	Belcher	agradeconstruct@gmail.com
Allen Engineering, Inc. - probably not quoting	Professional and Consulting Services, Information Technology	859-229-7362	Lilli	Allen	inallen2509@yahoo.com
All-N-One Services, LLC	Safety Products Distributor	281-812-3553	E. Ann	Gulix	anngulix@all-n1.com
All Safe Industries	Construction and Construction Subcontracting Services	502-499-7988	Wendy	Dunn	sales@all-safeindustries.com
Allterrain Paving and Construction, LLC	Professional and Consulting Services: Instruction and Education	502-265-4731	Maria	Triplet	mtriplett@allterrainpaving.com
All Things Diverse	Professional and Consulting Services: Architectural, Construction Management, Engineering and Survey	619-669-8689	Tammy L.	Hodo	tammy@allthingsdiverse.com
Anderson Business and Consulting Resources, LLC	Background Checks, Drug Testing Services	513-262-3021	Margie	Anderson	abcrn@abcr.com
Apollo Drug Screening LLC	Large Format Printer: Banners, Wall Graphics, Window, Floor Graphics & Decals, Vehicle Wraps, Directional Signage	877-930-7243	William	Knight	wknight@apolodrugscreening.com
AR2 Engineering, LLC	Cultural, Environmental Resources Consulting	248-735-9999	Janice	Foersterling	janice@screenworks.graphics
ASC Group, Inc.	Seller of Medical Supplies, Pharmaceuticals, Printer Cartridges	614-268-2514	Jill	Kunkel	jkunke@ascgroup.net
ASE Direct, Inc.	Professional and Consulting Services, Technology	888 204-1938	Lynn	Todd	ltodd@asedirect.com
ASK IT Consulting Inc.	PPE and Medical Supplies	631-649-1313	Manisha	Gupta	govt@askitc.com
A-T Medical Group LLC	Engineering & Surveying	917-287-8177	Collin	Hall	kate@a-t-medical.com
BA Engineers, Inc.	Bailey Construction & General Contracting, LLC dba Cable 2 Rur Commercial Construction, Skilled and General Labor	502-775-5741	Jeffrey	Bryant	jbryant@bryant-enrgs.com
Bailey Construction & General Contracting, LLC dba Cable 2 Rur Commercial Construction, Skilled and General Labor	Construction Training and Consulting: Classes, Safety Manual	502-333-4768	Cory	Bailey	cory.bailey@baileycgc.com
Bailey Safety, Inc.	Electrical Wholesaler	502-291-0596	Nancy	Bailey	nancyb@baileysafety.com
B & S Electric Supply	Labor to Place & Tie Reinforcing Steel/SIP Forms	502-261-0442	Charlie	Waits	c.waits@b-s-electric.com
Bar-Tie Reinforcing, Inc.	Information Technology Consulting and Staffing Services	812-534-3707	Mary Jane	Kincaid	bartiereinforcing@earthlink.net
Beacon Systems, Inc.	Planning and Design Consultants for Local, Regional State Agencies	954-426-1171	Lucy	Garcia	lgarcia@beacongov.com
Behan Associates Landscape Architecture dba Behan Planning	Construction, Industrial and Manufacturing, Professional and	518-339-3969	John J	Behan	jbehan@behanplanning.com
Benson Group LLC	Office Furnishings, Office Supplies, Ergo Seating, Modular Workstations	502-767-6878	Alan	Benson	abenson@bensongroupinc.com
Bentco Office Solutions LLC	Turn Key Billing Solutions, Revenue Cycle Management, Cash Management	423-756-6198	Edward	Bentley	edwardb@bentcooffice.com
Better Medical Billing Solutions	HVAC, Mechanical Contractor	859-213-8727	Jimmie	Powell	info@bmedicalbillingsolutions.com
Bison Services LLC	Commercial Cleaning, Interior Construction Cleaning	606-747-0322	Jason	Meloche Jr.	jimeloche@bison-services.com
BlackDiamond 1, LLC	Construction Contracting and Subcontracting Services	859 272-0443	Isaiah	Stovall	istovall@blackdiamond1.net
Blaze Enterprises, LLC	Commercial, Industrial Electrical Contractor	606-663-1003	Cara	Anderson	blazeenterprisesllc@yahoo.com
Bluegrass Electrical Consultants, Inc.	Lighting Protection	859-371-2583	Terry	Metcalfe	terry.metcalfe@becincky.com
Bluegrass Lightning Consultants, Inc.		502-673-8866	Kris	Phillips	bluegrass@bardstown.com

Brand Advertising Group	Advertising, Marketing, Web Services, Research	859-293-5760	Susie	Merida	susie@baglex.com
Brockington and Associates, Inc.	Cultural Resources Management: Archaeology, History, Histo	770-662-5807	Michael	Wash	michaelwalsh@brockington.org
Brownfields Development, LLC	Environmental Consulting and Contracting Firm	502-741-3805	Theresa	Bascom	tbascom1@bellsouth.net
Business Integria	Business, Offices Services, Professional and Consulting	301-474-9600	Prathiba	Ramadoss	Prathiba@businessintegria.com
Cal Vet Integrated Consulting Services, Inc.	Information Technology, Instructional and Education	916-524-6375	Wayne	Walker	wayne.w@cvicsconsulting.com
Careers USA, Inc.	Professional and Consulting Services, Temporary Labor	561-995-7000	Jennifer	Johnson	johnson@careersusa.com
Carolyne's Crown & Glory Beauty Salon, LLC	Professional Service, Product, Salon Equipment	859-266-8389	Carolyn	Dunn	cdstylist96@gmail.com
Cascade Engineering, Inc.	Environmental Engineering, Consulting	606-975-4883	Caori	Hindley	caori.hindley@cascadeny.com
CE HUGHES MILLING, INC.	Pavement Milling & Cleaning Services	812-725-8665	Caroline	Hughes	caroline@hughesmilling.com
Cedar Valley Seeding, Inc.	Highway, Site Seeding, Erosion Control, Landscaping	859-987-1497	Susan	Redmon	cvseeding@outlook.com
CentraComm	Technology, Computer Networking, Document Imaging,		Lynn	Child	diversity@centracomm.net
Chef Doug's Gourmet Foods, LLC	Software and Web Site Development	419-423-2666	Doug	Johannes	Djohannes69@gmail.com
Cestusline Inc.	Full Service Catering, Personal and Mobile Catering,	859-585-1464	Charles	Aybar	charles@cestusline.com
Cimtech, Inc.	Manufacturer and Distributor of Gloves, Personal Protective		Jesika	Young	jesika@cimtechmachine.com
Civil Design, Inc.	Equipment, Medical and Safety Supplies	503-894-8549	Lori	Daiber	ldaiber@civilidesigninc.com
Clint Chemical & Janitorial Supplies, Inc.	Computer Integrated Manufacturing Technology Company	812-948-1422	Angela	Hinkle	sales@clintchemicals.com
CMI Consulting, LLC	Janitorial, Safety Supplies, Equipment Distributor	314-881-5467	Beverly	Clemons	beverly@cmiconsulting.com
Commonwealth Capital Corp	Human Resources Consulting	859-296-2800	Kimberly	Springsteen-Abb	ksourmestien@cclease.com
Conco Spray Solutions, LLC	Equipment Leasing and Finance Company	877-654-1500	Jennifer	Hoop	jhoop@concospray.com
Connico Incorporated	Provider of Protective Linings for Water and Wastewater	Indi 317-428-6543	Jill	Johnson	marketing@connico.com
CONSOIDATED CORDAGE CORP	Architectural/Engineering Consulting and Management	615-758-7474	Renee	Ciaccio	businessdevelopment@consolidatedcord
Construction Supplies Online	Government & Military Specification: Braids, Bungee,	561-347-7247	William	Brazley	sales@constructionsupplyonline.com
Cope Plastics, Inc.	Supplier of Construction Materials	502-891-2541	Carl	Brown	sales@copeplastics.com
Cornerstone Engineering, Inc.	Industrial and Manufacturing: Plastics, Plexiglas, Resin,	Rosin 502-499-8884	Chella	Subram, P.e., Seel	cbrown@copeplastics.com
Cott Systems, Inc.	Engineering Consulting Services	502-493-2717	Elana	Bowman	information@cottsystems.com
CREBAD8 LLC	Technology: Recording, Imaging, Searching Land and	Court R. 800-234-2688	Gregorio	Palomino	gpalomino@cre8ad8.com
Critical Environmental Solutions	Full Service Event, Travel Management Company	210-846-8900	Bob	Soffel	Bob@CES.Works
Crown Services INC	Electrical Engineering Firm, Electrical Optimization, Demand		Ben	Donaldson	b.donaldson@crownservices.com
Crown Services, Inc	Reduction, Industrial Operations	859-621-6751	Ext Lisa	Stinnett	lstinnett@crownservices.com
Culy Contracting, Inc.	Staffing Services	859-223-4286	Jon	Moore	jonm@culycontracting.com
D3 Group Contracting	Staffing, Employment Services	614-844-5429	Dave	Kremzar	davekremzar@gmail.com
D.A.G. Construction Co., Inc.	Construction, Engineering Construction: Bridges, Dams,		Gregory	Webb	gwebb@dag-cons.com
DAW Cleaning Service, LLC	Pipelines, Waterworks, Underground, Utility	765-584-8509	Andre	Wilson	pressure97@gmail.com
Daniel Penn Associates LLC	Construction, Contracting and Sub Contracting	502-428-1054	Ken	Golden	kgolden@danielpenn.com
Dapple Advertising	General Contractor, Construction Manager,	513-542-8597	Sherry	Akers	sherry@dapple.net
Datagain Inc.	Commercial, Residential Cleaning: Brick, Vinyl, Pressure	Was 859-309-1513	Vivek	Jha	vivek@datagain.com
Deantocorporation, LLC	Management Consulting and Training Firm	860-232-8577	Andre	Tonye	andre.tonye@deantocorporation.com
Deccan International	Promotional Products and Wearables	859-263-3939	Pang	Moua	pangm@deccanintl.com
Diverse Staffing Services, Inc. DBA DSS Consulting	Technology Software Development and Service	201-598-1767	Amber	Roberts	avillalobos@diversestaffing.com
Diversified Adjustment Service, Inc.	Bridges, Construction Management, Engineering, installation	713-444-4379	Ray	Young	diversity@diversifiedadjustment.com
Done it All Construction	Technology, Software , Software and Web Site Development	858-764-8400	Justin	Young	doneitalconstruction@gmail.com
Doss & Horky, Inc.	Professional and Consulting Services, Technology	317-813-8000	Chad	Miller	chad@dossorky.com
	General Construction, Construction Contracting and	763-783-2322			
	Subcontracting Services	859-312-0645			
	General Contractor	859-236-5912			



Imprint, LLC	Professional and Consulting Services, Executive Coaching,	859 312-0141	Michelle	Hollingshead	michelle@imprintcoaching.com
Innovative Business Concepts, Inc.	Office Supplies Shop: Print, Sign, Swag, Design	270-866-3490	Jeannine	Bennett	jeannine@ibcprint.com
Inshaallah General Contractor LLC	General Construction Contracting	859-489-4707	Saburah	El-Amin	cinshallah@gmail.com
Inside Out Design, LLC	Construction Design	502-695-7020	Michael	Mueller	michaelm@insideout-design.org
Integrated Engineering, PLLC	Civil Engineering Consulting	859-368-0145	Eddie	Mesta	eddie@int-engineering.com
Interpreting Service of the Commonwealth, LLC	Interpreting Services, American Sign Language	606-401-2328	Becky	Bush	becky@iscy.net
Jackson Group	Environmental and Engineering Services	859-623-0499	Rick	Wolfe	twolfe@jacksongroup.com
JAM Distribution LLC	Uniform and Promotional Products Company	859-278-8418	Don	Taylor	don.taylor@ancpromotions.com
JASMINE KY LLC dba Code My Pipe	Data management, Data processing, Chinese translation	859-539-2218	Cindy	Bischoff	cindy.bischoff@jasmineky.com
JIC Maintenance LLC	Construction	502-426-2008	Nilo	Javier	njavier1@bellsouth.net
Joash Construction, Inc.	Janitorial Services	502-419-8268	Patricia	Kim	patriciawkim@gmail.com
JW Affinity IT, LLC	General Contractor, Concrete Flat Work, Sport Surfaces Cons	502-664-9737	Joseph	Scott	JScott@JoashConstruction.com
KAMICO Instructional Media, Inc.	Professional and Consulting Services, Information Technology	303-946-6642	Tracy	Ramirez	tramirez@jwaffinityit.com
KHAFRA Engineering Consultants, Inc.	Educational Books and Games, Software, Professional Develo	254-947-7283	Kathy	Michael	kmichael@kamico.com
KHIT Consulting	Engineering, Full Service	502-584-8599	George	Jeffries	gjeffries@khafra.com
KPC Architectural Products, Inc.	IT Consulting Company	502-203-1050	Katie	Hutchinson	khutchinson@khitconsulting.com
K. Hayes Limited	Full Service Commercial Furniture Company: Offices, Lounge				
Kentucky Cut Stone, LLC	Areas, Libraries, Classrooms, Meeting Rooms, Cafeterias	859-269-3646	Angle	Smith	ansmith@bluegrass.net
KERSEY AND KERSEY ARCHITECTS	General Contracting	859-333-8887	Kunte	Hayes	kunte@khayeslimited.com
Landstory	Natural Limestone Quarry Producer: Buildings, Landscape an	606-669-1174	JoE.E.	Ford	Kycutstone@gmail.com
L & C Management, Inc.	Professional Design Firm: Architecture, Planning and Interior	502-583-0094	Cheryl	Kersey	ckersey@kerseyandkersey.com
Leadership Excelleration, Inc.	Landscape Architecture Planning & Design	317-951-0000 Ext. Joann	Charles	Green	jgreen@landstoryla.com
Lean Continuous Improvements dba: Battle Plan Solutions	Construction Management, Business Development, Property	859-621-2482	Michelle	Thomas	thomasbuilder@aol.com
LECGI Inc	Professional Consulting Services: Team Development, Coachi	513-677-0995	Greg	Battle	Michelle-Pennington@let-consulting.com
Leonard Engineering, PLLC	Signage, Vendor management	502-649-4557	Heather	Kelly	gbattle@battleplansolutions.com
Lestar Mineral Development Inc.	Engineering Consulting, Structural Steel Design and Detailing	502-425-1647	Eleanor	Leonard	hkelly@lecpil.us
Lexington Contracting LLC	Structural Engineering	502-645-2802	Lester	Boyd	elleonor@leonardengineering.net
LGC Global Energy FM, LLC	Burner Fuel, Liquid Asphalt, Steel Fabrication, Material Hand	859-608-9926	Allen	Carter	lester@lestarinc.com
LGI Branding LLC	Construction, Install Doors, Concrete, Roofing, Painting, PE	859-281-6881	Fred	Feliciano	alexcontracting@aol.com
Lightly LLC	Integrated Facility Management, Asset Management, Enviror	313-989-4141	Lisa	Goshon	fred.feliciano@lccorp.com
Lone Camel PLLC	Manufacturer and Wholesale Distributor of PPE, Business De	425-409-1173	Kevin	Slaughter	info@lgbranding.com
Low 7 Consulting	Electrical: Lighting, Maintenance, Energy Savings	502-644-7084	Daniel	Bessman	kevin_slaughter@outlook.com
L Watson Trucking	Food and Beverages; Transportation	831-224-6380	Garrett	Dean	daniel.bessman@gmail.com
Make it Plain Consulting, LLC dba MIPC	Engineering Services, Construction Project Management	502-907-2167	Lenore	Lopez	garrett@lone-camel.com
Marine Solutions, Inc.	Commerical Cleaning, Painting and Maintenance Repair Ser	804-937-2206	Larry	Watson	lenorelopez28@yahoo.com
Mary's Cleaning Service	Trucking (Dump Truck), Haul Rock, Asphalt, Soil, etc.	502-387-9211	Tommie	Lewis	lwatsontrucking@icloud.com
Maverick Oxygen & Respiratory Equipment	Professional Consulting Services: Management, Human Reso	513-421-2300	Don	Wilkins	Tommielewis@mipclic.com
McCoy Computer Services, LLC	Marine Engineering and Commercial Diving	859-260-1055	Mary	Anthony	dwilkins@msimarinolutions.com
McPherson, Berry & Associates, Inc.	Cleaning, Janitorial Services, Equipment, Products and Suppl	859-270-9509	Ben	Kitleson	marystephanthony@yahoo.com
MCT Pro Tools	Single Source Provider of Respiratory Equipment, Liquid	502-225-4772	Dedrea	McCoy	ben@maverickoxygen.com
Mercedes Medical, LLC	Oxygen, Oxygen Cylinders, Related Products and Services	502-517-4998	LaSonya	Berry	dedrea.mccoy@mccoycomputerservices.c
	Computer, Technology, Security Services	800-325-5269	Kevin	Del Valle	lasonya@mcphersonberry.com
	Professional and Consulting Services: HR Consulting, Diversit	631-278-9127	Brooke	Nieciestro	kdelvalle1231@gmail.com
	Building Maintenance and Materials, Medical, Health,				
	Manufacturing, Industrial, Power and Energy, Safety				
	Medical and Health Services and Supplies	800-331-2716			

Messier & Associates Inc.	Engineering Support Services, Construction, Trucking	502-533-4573	Fernando	Messier	fernessler@hotmail.com
Metric Environmental, LLC	Environmental Services Consulting Company	317-400-1633	Kenneth	Beache	marketing@metricenv.com
Metro Fence Industries, Inc	Fence Installation	502-458-8701	Brenda	Jett	brenda@metrolenceinc.com
Meyer, Scherer & Rockcastle, Ltd dba MSR Design	Architecturer and Interior Design	612-375-0336	Douglas M	Franzwa	doug@msrdesign.com
Michael T. Jones & Co, LLC	Industrial Control Panels and Electrical Assembly	859-405-0878	Zac	Jones	ZJones@mtjcollc.com
Millennium Learning Concepts	Professional and Consulting Services: Education, Instruction,	859- 420-8032	Dr. Roger	Cleveland	drmic2005@gmail.com
Mills Supply Co., Inc.	Construction, Building Maintenance and Materials	502-561-0700	Kathy	Mills	kathy@millsupply.net
Mindel Scott & Associates, Inc. dba Mindel Scott	Professional Consulting and Design/Build Services	(502) 485-1508	Amanda	Smith	asmith@mindelscott.com
Natively Fluent	Multimedia Services: Translation, Localization, Written Text	949-735-7522	Kamran	Khan	Bids@NativelyFluent.com
New Towne Consultants	Consultants, Project Management, Administrative, Bookkeep	502-931-3638	Robin	Hall	newtowneconsultants@gmail.com
New West LLC	Public Relations, Marketing Services, Graphic Design,	502 891-2500	Bernadette	Faris	BFaris@newwestagency.com
Next Century Technologies	IT Consulting	859-806-5757	Tracy	Hardin	tracy@ky-consultant.com
Nextgen Consulting, Inc. - dba NGCI	Professional and Consulting Services, Technology	202-527-9595	Saif	Rehman	saif_rehman@ngciglobal.com
Norton Medical Industries	Medical and Health	800-243-7669	Marshall	Zablen	admin@nortonmedical.com
NovaLight Telecom Supply	Construction, Maintenance, Fiber Optic, Copper Networks	Pr. 706-301-9046	Allen	Creighton	allen.creighton@novalight.com
NWK Construction, Inc.	HWY Construction	859-733-0763 Ext.	Nickie	Kendrick	nwkconst@aol.com
Nysrak, llc	Construction, Professional and Consulting Services: Utility (				
Olani Associates LLC	telecom) Inspection, Consultation, Damage Investigation	859- 433-7708	Bruce	Harris	bruceharris@nysrak.com
O'Rourke Wrecking Company	Professional and Consulting Services, Technology, Power	202- 255-9046	Anyi	Elekwach	rfps@olanassociates.com
Overhead Door Corporation of Lexington, Inc.	Construction and Subcontracting Services, Turnkey				
Paladin, Inc.	Demolition, Site Recovery Services,	513-871-1400	Michele	O'Rourke	morourke@ourkewrecking.com
Paper Clip Supply	Building Maintenance and Materials, Environmental,	859- 254-6606	Rodney	Greene	rgreene@buddlex.com
RNC Communications dba RCN Technologies	Engineering and Commissioning Services	859-252-3047	Candice	Rogers	rogersc@paladinky.com
	Office, Janitorial, Food Service, Daycare Classroom Supplies	a 201- 966-7894	Alexander	Nunez	cs@paperclipsupply.com
	Public Sector Technology Provider	865-293-0350	Emily	Schmidt	emily_schmidt@rcntechtechnologies.com
Personal Opinion, Inc.	Professional and Consulting Services	502- 899-2400	Rebecca	Davis	rebecca@personalopinion.com
Pinnacle Petroleum, Inc.	Petroleum Products and Services	714-841-8877	Liz	McKinley	lmckinley@pinnaclepetroleum.com
Plant Services Incorporated	Industrial Services	502- 868-2240	Scott	Wilson	swilson@psi-ky.com
Premier Building Maintenance Corporation	Facilities Services	865-522-7731	Michael	Franklin	mfranklin@premierebuilding.com
Premier Workforce Training and Development	Workforce Training and Developer	210-425-0065	Lee	Little	Leelittle-pwtd@outlook.com
Printcore, Inc.	Commercial Printing and Packaging Company	859- 351-4596	Ray	Woods	Rayw@printcoreinc.com
Professional Fence Co.	Fence Contractor	502-222-0513	Bob	Osmer	bobosmer@bellsouth.net
Pro-Mark Inc.	Stripping, Thermo plastic, Markers	859-497-0533	Amy	Hibben	amyhibben@gmail.com
Prometheus Foundry, LLC dba Prometheus Art	Design, Fabrication, Casting of Metal Work	502-592-3774	Amanda	Matthews	amfieldstart@yahoo.com
Prowess Uniform Solutions, Inc.	Domestic Apparel, Security, Public Order and Safety Supplies	502-545-2582	Eric	Lynes	elynes@prowessuniform.com
Public Safety Consultants and Associates	Safety Prevention Programs, Inspection, Risk Assessment, Fir	859-321-1781	William	Swope	publicsafetyconsultants59@gmail.com
QTS Group	EHS Consulting	917- 376-6271	Danaila	Paspalanova	dpaspalanova@qtsgrp.com
Quintairos, Prieto, Wood & Boyer, P.A.	Professional and Consulting Services: Legal and Arbitration	502-226-0057	Christine L.	Stanley	christine.stanley@qpwbaw.com
Rang Technologies, LLC	Professional and Consulting Services, Information Technology	732- 947-4119	Jigar	Patel	sales@rangtech.com
Rasor Marketing Communications	Full Service Marketing Communications Firm	513-793-1234	Elyn	Buscani	elyn@gorasor.com



Realistic Computing, Inc. DBA RCA Inc.	IT Services	410-744-8144	Sequoia	Ramsey	sramsey@realistic-computing.com
Reclaim Company, LLC	Building Maintenance, Materials, Construction, Environment	304-366-7070	Angle	Mitchell	amitchell@reclaimco.com ffp@reliant-cap.com
Reliant Capital Solutions, LLC	Professional and Consulting Services	614-452-6100	Jenna	Sharick	kvaughn@ritequality.com
Rite Quality Office Supplies, Inc.	Office Supplies, Furniture, PPE, Janitorial/Sanitization and Safe	800-580-7483	Kimberly	Vaughn	bids@rkpetroleum.com
RKA Petroleum Companies, Inc.	Industrial, Manufacturing, Fuels, Fuel Additives, Lubricants	734-946-2199	Jasmine	Hofbauer	sdcmtg@gmail.com
S & D Construction Management Inc.	General Construction, Demolition, Asbestos, Lead & Mold Ren	859-226-0083 Ext.	Sean	Edwards	mbaiker@mr1c.com
S & M Contracting, LLC	Construction Contracting and Subcontracting Services	606-743-7090	Melanie	Barker	bgraf@smprecast.com
S & M Precast, Inc.	Precast Products	812-246-6258	Becky	Graf	scrump@srca.net
Safety Research Corporation of America	Information Technology, Software Design and Development	1334-797-1007	Susan	Crump	
Salsa Professional Apparel dba Salsa Professional Apparel & Supplies/Salsa Industrial Supply	Facility Management Supply Company	212-575-6565	Gigi	De Jesus	Gigi@SalsaIndustrialSupply.com
Salt River Engineering	Engineering Consulting Services	859-734-2334	Connie	Allen	connie@saltrivereng.com
Scruggs Construction Inc.	General Construction Contractor: Concrete Construction, Der Cleaning Services: Commercial, Custodial, Janitorial; Grounds, Landscape, Lawn Maintenance Equip., Machinery and Supplies; Construction, Contracting and Sub Contracting	812-528-8178	John	Scruggs	montscruggs@gmail.com
Semper TEK, Inc.	Technology, Communications	859-358-6386	Tara	Brinkmoeller	tamb@sempertekinc.com
SENCOMMUNICATIONS, INC.	Environmental; Industrial Manufacturing, Building Civil Engineering, Consulting Firm: Water Resources	859-252-8339	Stacie	Miller	lgeneral@sencomm.com
Sensabaugh Design & Construction, LLC	Engineering, Transportation, Aviation Engineering	317-841-4799	Robert	Sensabaugh	jsensabaugh@windstreath.net
Shrewsbury & Associates, LLC	PPE Supplies	516-226-3449	Muhammad	Rush	trush@shrewsusa.com
Sidra Medical Supply, Inc.	Bore, Jack Steel Casings for Utilities and Horizontal Drains	606-872-4142	Angela	Momen	moment@sidramedicalsupply.com
Singleton Road Boring, Inc.	PRINTING	502-489-9459	Greg	Singleton	afs@singletonroadboring.com
SIMPLY GRAPHICS	FFL Firearms and Accessories Dealer	502-931-3172	KeOliver 'Ski	Thompson	simplygraphics@bellsouth.net
Skips Defense Solutions	Professional and Consulting Services	502-235-6459	Stephanie	McCall	skipmccall@me.com
SL Consulting Solutions, LLC	Transportation and Logistics; Hire Trucking, Hauling, Disposal Services	859-977-6640	Delonzo	Lackey	slconsultingsolutionsllc@gmail.com
SLI Contracting, LLC	Hardware, Software Information Technology Supplier, Staffing Services	734-238-1553	David	Wilder	wilderd@sealinglife.com
SMART IT PROS INC	Landscape, Lawn Care, Sewer Construction, General Construct	859-296-1624	Cindy	Thomas	dave.thomas@smartitpros.com
Something 'Bloomin'	Building Maintenance and Materials, Construction, Professio	954-641-8754	Philip	England	sbloomin@aol.com
Southern Lighting Group	Teleconferencing Services Company: Audio, Video, Web Cont	866-257-1425	Rebecca	Kloc	info@southernlightinggroup.com
SpeakSpace LLC	Construction, Contracting and Sub Contracting	877-561-4967	Danica	Behan	beckybehan@speakspace.com
Spectrum Contracting Services, Inc.	Power and Energy, Utility Services, Electric, Gas, Sewer, Wate	513-621-1113	Carla	Fick	dfick@spectrumcontract.com
Stand Energy Corporation	Professional, Consulting Services, Information Technology Se	502-813-8043	Christopher	Plening	cpiening@standenergy.com
Strategic Communications LLC	Operations and IT Services	859-300-3321	Adam	Payne	cpayne@yourstrategic.com
Structured Inc.	Finish Grading, Landscaping: Seed, Strawing, Hydroseeding, Security, Public Order and Safety, Personal Safety	E 812-246-4839	Charlene	Leake	adam@structured-inc.com
Summers Grading Service LLC	Electrical Contractor	919-398-6445	Carol	Summers	SUMMERSGRADING@YAHOO.COM
Sunstates Security, LLC	Technology, Security, Public Order and Safety	502-454-0101	Tommy	Drumheller	cdrumheller@sunstatesecurity.com
TEM Group	IT Consulting and Services	502-276-2829	Gus	Clark	tclark@temelectric.com
Team Fishel	Professional and Consulting Services: Curriculum Developme	336-971-0385	Antwain	Dattilo	avdattilo@teamfishel.com
Technosoft Corporation dba Apexon	Urban Design, Landscape Architecture, Community Planning,	502-595-7432	Amy	Patel	Setu.Patel@apexon.com
Tate Consulting TC, LLC	Professional and Consulting services, Technology Solutions,	303-693-7263	David	Goode	antwaingoode@tateconsulting.org
Taylor Siefker Williams Design Group				Williams	awilliams@tswdesigngroup.com
The Arcanum Group, Inc.				Marshall	david_marshall@theArcanumGroup.com

The Decor Group of Northern Ky., Inc.	Landscaping, Lawn Maintenance, Holiday Decorating	859-586-4784	Karralea	Stickrod-list	klst@decorgroupny.com
The Fence Co., Inc.	Fencing	270-259-3808	Judy	Braun	thefencecoofky@gmail.com
The Matrix Group, Inc.	Market Research, Professional and Consulting Services	859-263-8177	Martha	DeReamer	matre@tmresearch.com
The Silicon Black Group, LLC	Information Technology Consulting: Cybersecurity, Strategic	312-298-9892	DeWayne	Cassel	dcassel@thesiliconblackgroup.com
The Traffic Group, Inc.	Traffic Engineering, Transportation Planning, Graphic Design	410-931-6600	Tracey	Rogers	trogers@trafficgroup.com
Third Rock Consultants, LLC	Environmental Consulting Services	859-977-2000	Molly	Foree	mforee@thirdrockconsultants.com
TKT & Associates, Inc.	Consulting & Management Services; Specialized Staffing	502-499-9440	Dorothy	Abernathy	dorothy@tktinassociates.com
TKT-nectir Global Staffing LLC	Staffing Service	502-499-9440 Ext.	Dorothy	Abernathy	dorothy@tktinassociates.com
TMI Coatings, Inc.	Construction: Contracting and Sub Contracting; Industrial	651-452-6100	Tracy	Glori	tmi@tmi-coatings.com
Toni Levy & Associates, Inc	Accounting, Tax, Audit, Electrical & Plumbing Supply, Building	502-566-3030	Glenda	Berry	gb@tonilevya.com
Tracking Solutions	Technology, Inmate Monitoring Systems and Services	615-337-9367	Kristen	Zachary	Kristen@TrackingSolutionsNow.com
Tri-A solutions	Construction: Concrete Contractor	859-380-0807	Austin	Flaughner	austin@tri-a.net
Tri State Plastics	Construction and Machining	859-655-8200	Lisa	Schneider	lisa@tristateplastics.com
Trimen Solutions, LLC	Human Resources and Business Consulting	502-365-2747	Shaun	Spencer	shaun@trimensolutions.com
TruTest, LLC	Full Service Sewer Testing and Repair Company	502-552-9022	Kristi	Conrad	trutestseals@yahoo.com
Unique Staffing LLC	Professional Services: Educational Training, Human	502-425-3715	John R.	Fleming	ufleming@uniquestaffingllc.com
Universal Spartan, LLC	Tactical Gear	270-501-2210	Alejandro	Ramirez	salesuniversalspartan@gmail.com
Untold Content, LLC	Grant, Technical, Research and Writing Consultant	859-866-1916	Kathryn Trau	Taylor	katie@untoldcontent.com
Urban Industries, LLC	Professional Commercial Cleaning Services	859-230-1784	Ron	Mack	ronmack@urbanindustries.us
Vanaire	Manufacturers of Corrosion Resistant Pollution Control Equip	502-491-3553	Ron	Weihe	ron@vanaire.com
Vantage Energy Consulting, LLC	Regulated Utility and Energy Consulting Services	305-744-3440	Jean	Gormley	gormley@vantageenergyconsulting.com
Vehicle Maintenance Program, Inc.	Transportation, Vehicle Parts, Repair and Accessories,	561-362-6080	Lindi	Brooks	lindi@vipparts.com
VeriCorp, Incorporated	Office, Business, Professional, Consulting Services,	502-554-9999	Britany	DeWitt	britanyd@vericorp.com
Victory Supply, Inc.	Inmate Clothing and Supplies	931-325-5517	Lisa	Fiore	bids@victorysupply.com
Vision Engineering	Engineering Consultant	859-559-0516	Jihad	Hallany	jhallany@visionengr.com
Vitalink Communications	Purpose Driven Marketing and Branding Firm	919-850-0605	Kathy	Horn	kathy@vitalinkweb.com
Vivian Liambi & Associates, Inc.	Landscape Architecture & Civil Engineering	513-559-9444	Vivian	Liambi	vivian.liambi@via.net
VT Design Solutions	Construction, Engineering Construction, Building and	937-476-2200	Al	Wofford	Al.Wofford@cdotech.com
V-Soft Consulting Group, Inc.	Professional Consulting Services: Information Technology	844-425-8425	David	Stith	proposals@vsoftconsulting.com
Wasteology Group Transportation, LLC	Waste and Recycling Brokerage: Specialized Reporting,	502-643-2285	Stacey	Harralson	wbe@wasteologygroup.com
Waypoint, LLC	Ecological Consulting	859-797-7466	Jesse	Robinson	jesse@waypointllc.com
Willow Hill Supply, LLC	Manufacturer of Embroidered Patches, Insignia, Supplier of	859-355-5244	Lillian	Gorman	willowhillsupply@gmail.com
Williams Distribution, LLC	Chemical Distribution Company	317-749-0006	Marshall	Williams	info@williamsdistllc.com
Wiser Strategies	Communication Consulting	859-887-0866	Nancy	Wiser	nancy@wiserstrategies.com
Work - Comp Management Services, Inc.	Occupational Health, Medical Health, Wellness Onsite Service	877-449-7473	Julie	Ott	jott@workcomps.com
Wrap City Vinyl	Large Format Digital Printer	404-299-6100	Eula	Stewart	estewart@convoymarketing.com
Xpress Management Solutions dba Corporate Lodging Group	Construction Contracting and Subcontracting Services;	859-312-1861	Nicole	Hime	NICOLE@XPRESSMANAGEMENTSOLUTION
YLB Accounting & Consulting Services	Accounting Services, Human Resources, Food Service & Cater	502-647-3027	Yolanda	Bradford	ylbacct@bellsouth.net
Yoshis Industrial Packaging Supply, LLC	Re-sale, Distributor, Hand tools, Safety Items, Industrial	270-681-4817	Beverly	Foster	beverly.foster@yoshissupply.com
	Supplies, Janitorial Supplies, Protective Gear, Food Service,				