



LEXINGTON

Lexington-Fayette Urban County Government

Lexington, Kentucky
Horse Capital of the World

**CONTRACT DOCUMENTS
AND
SPECIFICATIONS**

DIVISION OF PARKS AND RECREATION

FOR

**Concrete Tee Pads and Sign Posts for Disc Golf
Course**

Bid No. 33-2026

TABLE OF CONTENTS
CONTRACT DOCUMENTS

PART I	ADVERTISEMENT FOR BIDS
PART II	INFORMATION FOR BIDDERS
PART III	FORM OF PROPOSAL
PART IV	GENERAL CONDITIONS
PART V	SPECIAL CONDITIONS
PART VI	CONTRACT AGREEMENT
PART VII	PERFORMANCE AND PAYMENT BONDS
PART VIII	ADDENDA
PART IX	TECHNICAL SPECIFICATIONS AND PLANS

PART 1

ADVERTISEMENT FOR BIDS

INDEX

1. INVITATION
2. DESCRIPTION OF WORK
3. OBTAINING PLANS, SPECIFICATIONS, AND BID DOCUMENTS
4. METHOD OF RECEIVING BIDS
5. METHOD OF AWARD
6. BID WITHDRAWAL
7. BID SECURITY
8. SUBMISSION OF BIDS
9. RIGHT TO REJECT
10. NOTIFICATION TO THE LFUCG FOR AFFIRMATIVE ACTION
11. NOTICE CONCERNING MWDDBE AND VETERAN GOALS – LFUCG
12. PRE-BID CONFERENCE

PART 1

ADVERTISEMENT FOR BIDS

1. INVITATION

Sealed proposals for the **Concrete Tee Pads and Sign Posts for Disc Golf Course** will be received by the Lexington-Fayette Urban County Government (LFUCG) via Ion Wave until 2:00 p.m., local time, **April 7, 2026** for furnishing all labor and/or materials and performing all work as set forth by this advertisement, Ion Wave Q&A, conditions (general and special), specifications, and/or the drawings prepared by Lexington-Fayette Urban County Government. Immediately following the scheduled closing time for reception of bids, all proposals which have been submitted in accordance with the above will be opened electronically and a bid tab sheet will be available via Ion Wave.

LFUCG will only be accepting bids from prime Contractors on-line through Ion Wave for this solicitation. Base bid and alternate totals (if required) should be provided on the appropriate line items tab on Ion Wave. Submissions without line item totals (if required) may be rejected and deemed non-responsive. All forms normally provided with bid submission should be downloaded from Ion Wave, filled out and attached with bid submission. A copy of bid bond must be included with submission. THESE INSTRUCTIONS SUPERCEDE ALL OTHER BID SUBMISSION INSTRUCTIONS PROVIDED IN THIS PACKAGE. PLEASE SUBMIT ALL QUESTIONS VIA THE Q&A MODULE ON ION WAVE.

2. DESCRIPTION OF WORK

Consisting of the construction and/or furnishing of items as listed in the Bid Schedule beginning on page P-6, Part III, Form of Proposal, of this document, for the **Concrete Tee Pads and Sign Posts for Disc Golf Course**, Lexington-Fayette County, Kentucky.

Specs and drawings are available on Ion Wave only.

3. OBTAINING PLANS, SPECIFICATIONS, AND BID DOCUMENTS

Plans, Specifications, and Contract Documents shall be obtained from Ion Wave (LFUCG's electronic bidding system). Ion Wave can be accessed at <https://lexingtonky.ionwave.net>

4. METHOD OF RECEIVING BIDS

Bids will be received from Prime Contracting firms **Lump Sum** basis for total Project. Bidder must include a price for all bid items to be considered. **Bids shall be submitted in the manner and subject to the conditions as set forth and described in the Information for Bidders and Special Conditions.**

Bids/proposals should be submitted online via Ion Wave.

5. METHOD OF AWARD

The Contract, if awarded, will be to the lowest responsive and responsible bidder for the total project whose qualifications indicate the award will be in the best interest of the OWNER and whose bid/proposal complies with all the prescribed requirements. No Notice of Award will be given until the OWNER has concluded such investigation as deemed necessary to establish the responsibility, qualifications and financial ability of Bidders to do the work in accordance with the Contract Documents to the satisfaction of the OWNER within the time prescribed. The OWNER reserves the right to reject the Bid of any Bidder who does not pass such investigation to the OWNER's satisfaction. The OWNER reserves the right to reject the Bid of any Bidder that is deemed to be unbalanced or front loaded. In analyzing Bids, the OWNER may take into consideration alternate and unit prices, if requested by the Bid forms.

6. BID WITHDRAWAL

No bidder may withdraw his bid for a period of ninety (90) calendar days after the closing date for receipt of bids. Errors and omissions will not be cause for withdrawal of bid without forfeit of bid bond.

7. BID SECURITY

If the bid is \$50,000 or greater, bid shall be accompanied by a certified check or bid bond payable to the Lexington-Fayette Urban County Government in an amount not less than Five Percent (5%) of the base bid. Bid bond shall be executed by a Surety Company authorized to do business in the Commonwealth of Kentucky and countersigned by a licensed Kentucky Resident Agent, representing the Surety Company. Bid Bonds are not required for bids under \$50,000. A cashier's check or irrevocable letter of credit is an acceptable form of bid security.

8. SUBMISSION OF BIDS

CONTRACTORS shall submit their bids via Ion Wave not later than 2:00 p.m. local time, **April 7, 2026**. Bids will remain sealed until **April 7, 2026**, 2:00 pm, the official Bid closure time. Bids will not be received after the scheduled closing time for receipt of bids. Bid tab sheet will be immediately available after bid opening, under the Documents link on Ion Wave.

9. RIGHT TO REJECT

The Lexington-Fayette Urban County Government reserves the right to reject any and all bids and to waive all informalities and/or technicalities where the best interest of the Lexington-Fayette Urban County Government may be served.

10. NOTIFICATION TO THE LEXINGTON-FAYETTE URBAN COUNTY GOVERNMENT FOR AFFIRMATIVE ACTION PLAN AND CURRENT WORKFORCE

The successful bidder must submit the following to the Lexington-Fayette Urban County Government:

1. Affirmative Action Plan for his/her firm.
2. Current Workforce Analysis Form

Failure to submit this as required herein may result in disqualification of the Bidder from the award of the contract.

11. NOTICE CONCERNING MWDBE and VETERAN OWNED SMALL BUSINESS GOALS

The Lexington-Fayette Urban County Government has a Certified Minority and Women Business Enterprise seventeen percent (17%) minimum goal including minimum subgoals of five percent (5%) for Minority Business Enterprises (MBE) and a subgoal of twelve percent (12%) for Women Business Enterprises (WBE); a three (3%) minimum goal for Certified Veteran-Owned Small Businesses and/or Certified Service- Disabled Veteran Owned Businesses; and a goal of utilizing Disadvantaged Business Enterprises (DBE), where applicable, for government contracts.

For assistance in locating certified DBEs, MBEs, WBEs, VOSBs and/or VOSBs, contact Sherita Miller at 859/258-3320 or by writing the address listed below:

Sherita Miller, MPA, CPSD
Minority Business Enterprise Liaison
Division of Procurement
Lexington-Fayette Urban County Government
200 East Main Street
Lexington, Kentucky 40507
smiller@lexingtonky.gov

12. PRE-BID CONFERENCE

A pre-bid conference is scheduled for March 30, 2026, 10:00 am at Coldstream Park at a pre-established construction entrance at Coldstream Park located adjacent to 1816 Arbor Station Way, Lexington, Kentucky.

END OF SECTION

PART II
INFORMATION FOR BIDDERS

INDEX

1. RECEIPT AND OPENING OF BIDS
2. PREPARATION OF BID
3. SUBCONTRACTS
4. QUALIFICATION OF BIDDER
5. BID SECURITY
6. LIQUIDATED DAMAGES FOR FAILURE TO ENTER INTO CONTRACT
7. TIME OF COMPLETION AND LIQUIDATED DAMAGES
8. EXAMINATION OF CONTRACT DOCUMENTS AND SITE
9. ADDENDA AND INTERPRETATIONS
10. SECURITY FOR FAITHFUL PERFORMANCE
11. POWER OF ATTORNEY
12. TAXES AND WORKMEN'S COMPENSATION
13. LAWS AND REGULATIONS
14. EROSION AND SEDIMENT CONTROL AND PERMITS
15. PREVAILING WAGE LAW AND MINIMUM HOURLY RATES
16. AFFIRMATIVE ACTION PLAN
17. CONTRACT TIME
18. SUBSTITUTION OR "OR-EQUAL" ITEMS
19. ALTERNATE BIDS
20. SIGNING OF AGREEMENT
21. ASSISTANCE TO BE OFFERED TO DBE CONTRACTORS
22. LFUCG NON-APPROPRIATION CLAUSE
23. NOTICE OF CONTENTION

PART II
INFORMATION FOR BIDDERS

1. RECEIPT AND OPENING OF BIDS

The Lexington-Fayette Urban County Government (herein called the OWNER) invites bids from firms on the project described in the Advertisement for Bids. The OWNER will receive bids via Ion Wave, at the time and in the manner set forth in the Advertisement for Bids, and the Bids. The OWNER may consider informal any bid not prepared and submitted in accordance with the provisions hereof and may waive any informalities or reject any and all bids. Any bid may be withdrawn prior to the scheduled time for the opening of bids or authorized postponement thereof. Any bid received after the time and date specified shall not be considered. No bidder may withdraw a bid within 120 days after the actual time and date of the bid opening, but OWNER may, in its sole discretion, release any bid and return the Bid Security prior to that date.

The Lexington-Fayette Urban County Government assumes no responsibility for bids that are not delivered as indicated above.

2. PREPARATION OF BID

All sections of the bid package requiring Contractor information must be filled in and uploaded in the Response Attachments tab in IonWave. Bid bonds must be uploaded also. All pricing must be submitted in the Line Items tab in IonWave.

3. SUBCONTRACTS

The bidder is specifically advised that any person, firm, or other party to whom it is proposed to award a subcontract under this Contract must be acceptable to the OWNER. All proposed subcontractors must be identified on the Form of Proposal. Prior to the award of Contract, the OWNER or the OWNER'S representative will advise the CONTRACTOR of the acceptance and approval thereof or of any action necessary to be taken. Should any Subcontractor be rejected by the OWNER, the CONTRACTOR shall present a new name and/or firm to the OWNER at no change in the Contract Price.

4. QUALIFICATION OF BIDDER

The OWNER may make such investigations as the OWNER deems necessary to determine the ability of the bidder to perform the Work, and the bidder shall furnish to the OWNER all such information and data for this purpose as the OWNER may request. The OWNER reserves the right to reject any bid if the evidence submitted by, or investigation of, such bidder fails to satisfy the OWNER that such bidder is properly qualified to carry out the obligations of the Contract and to complete the Work contemplated therein. Conditional bids will not be accepted.

In evaluating Bids, OWNER shall consider the qualifications of the BIDDERS, whether or not the Bids comply with the prescribed requirements, and alternatives and unit prices, as requested. OWNER may consider maintenance requirements, performance data, and disruption or damage to private property. It is OWNER'S intent to accept alternatives by the bid forms, in the order in which they are listed in the Bid Form but OWNER may accept or decline them in order or combination. The contract, if awarded, will be awarded to the lowest responsive and qualified, responsible BIDDER based upon OWNER'S evaluation which indicates that the award will be in the best interest of OWNER and the general public.

In the event there is any question as to the bidder's qualifications and ability to complete the work, a final determination will be made in accordance with a fair evaluation by the Urban County Government of the above listed elements.

- A. If the OWNER requires filling out a detailed financial statement, the bidder may provide its current certified financial statement(s) for the required time interval.
- B. Corporate firms are required to be registered with the Office of the Secretary of State, Commonwealth of Kentucky.
- C. Documents Required of CONTRACTOR - (1) A sworn statement signed by the President or owner of the Company regarding all current work in progress anywhere; (2) A document showing the percent of completion of each project and the total worth of each project; and (3) Documentation showing the percentage of the DBE employment levels on each project of the Bidder's current work force, and DBE participation levels for Subcontractors.
- D. Optional OWNER Requirements - The OWNER, at its discretion, may require the BIDDER/CONTRACTOR to provide: (1) A current detailed financial statement for a period including up to 3 prior years. (2) Financial security or insurance in amounts and kinds acceptable to the OWNER to meet the financial responsibility requirements for the CONTRACTOR to indemnify the OWNER. (3) Additional information and/or DBE work force data, as well as DBE participation data.

Each bidder agrees to waive any claim it has or may have against the Owner and their respective employees, arising out of or in connection with the administration, evaluation, or recommendation of any bid.

5. BID SECURITY

- A. Each bid must be accompanied by a bid bond prepared on a Form of Bid Bond and attached hereto, duly executed by the bidder as principal and having as surety thereon a surety company approved by the OWNER, in the amount of 5% of the bid. Such bid bond will be returned to the unsuccessful bidder(s) only upon written request to the Director of Procurement within seven (7) days of opening of bids. Bid bond shall be made payable to the Lexington-Fayette Urban County Government. Bid security is not required for projects under \$50,000.
- B. Bonds shall be placed with an agent licensed in Kentucky with surety authorized to do business within the state. When the premium is paid for such coverage, the full commission payable shall be paid to such local agent who shall not divide such commission with any person other than a duly licensed resident local agent.

6. LIQUIDATED DAMAGES FOR FAILURE TO ENTER INTO CONTRACT

The successful bidder, upon his failure or refusal to execute and deliver the Contract and bonds required within ten (10) days after he has received notice of the acceptance of his bid, shall forfeit to the OWNER, as liquidated damages for such failure or refusal, the security deposited with his bid.

7. TIME OF COMPLETION AND LIQUIDATED DAMAGES

Bidder must agree to commence work on or before a date to be specified in a written "Notice to Proceed" from the OWNER and to fully complete the Project within the time as specified in the Contract. Bidder must agree also to pay \$250.00 per day thereafter deadline for final completion.

8. EXAMINATION OF CONTRACT DOCUMENTS AND SITE

- A. It is the responsibility of each Bidder before submitting a Bid, to (a) examine the Contract Documents thoroughly, (b) visit the site(s) to become familiar with local conditions that may affect cost, progress, performance or furnishing of the work, (c) consider Federal, State and Local laws and regulations that may affect cost, progress, performance or furnishing of the work, (d) study and carefully correlate Bidder's observations with the Contract Documents, and (e) notify Owner of all conflicts, errors or discrepancies in the Contract Documents.
- B. Bidders should examine the requirements of Section 4 of the General Conditions for information pertaining to subsurface conditions, underground structures, underground facilities, and availability of lands, easements, and rights-of-way. The completeness of data, presented in the Contract Documents, pertaining to subsurface conditions, underground structures, and underground facilities for the purposes of bidding or construction is not assured. The Bidder will, at Bidder's

own expense, make or obtain any additional examinations, investigations, explorations, tests and studies and obtain any additional information and data which pertain to the physical conditions (surface and subsurface) which may affect cost, progress, performance or furnishing of the Work and which Bidder deems necessary to determine its Bid for performing and furnishing the Work in accordance with the time, price, and other terms and conditions of the Contract Documents. On request in advance, OWNER will provide access to the site to conduct such explorations and tests as each Bidder deems necessary for submission of a bid. Bidder shall fill all holes, clean up and restore the site to its former condition upon completion of such explorations.

- C. The submission of a Bid will constitute an incontrovertible representation by the Bidder that Bidder has complied with every requirement of this paragraph; that without exception the Bid is premised upon furnishing and performing the Work required by the Contract Documents and such means, methods, techniques, sequences or procedures of construction as may be indicated in or required by the Contract Documents; and that the Contract Documents are sufficient in scope and detail to indicate and convey understanding of all terms and conditions for performance and furnishing of the Work.

9. ADDENDA AND INTERPRETATIONS

No interpretation of the meaning of the Contract Documents will be made to any bidder orally. Every request for such interpretation should be in writing addressed to the Director of Procurement, who in turn will have an addendum issued under signature of the Project Manager for the Lexington-Fayette Urban County Government, and to be given consideration must be received at least seven (7) days prior to the date fixed for the opening of bids. Any and all such interpretations and any supplemental instructions will be in the form of written addenda to the specifications which, if issued, will be mailed by certified mail with return receipt requested, faxed or emailed to all prospective bidders. Failure of any bidder to receive any such addendum or interpretation shall not relieve such bidder from any obligation under his bid as submitted. All addenda so issued shall become part of the Contract Documents.

10. SECURITY FOR FAITHFUL PERFORMANCE

- A. Simultaneously with his delivery of the executed Contracts, the CONTRACTOR shall furnish a surety bond or bonds as security for the faithful performance of this Contract and for payment of all persons performing labor on the Project under this Contract and furnishing materials in connection with this Contract, as specified in the General Conditions. The surety on such bond or bonds shall be a duly authorized surety company satisfactory to the OWNER and authorized to do business in the Commonwealth of Kentucky.

- B. All bonds required by this Contract and laws of this State shall be placed with agents licensed in the State of Kentucky. When the premium is paid for such coverages, the full commission shall be paid to such local agent who shall not divide such commission with any person other than a duly licensed resident local agent.
- C. **Contractor shall use standard Performance and Payment Bond forms such as documents provided with this contract book or AIA form A312-1984 (or later).**

11. POWER OF ATTORNEY

Attorney-in-fact who signs bid bonds or contract bonds must file with each bond a certified and effectively dated copy of their power of attorney.

12. TAXES AND WORKMEN'S COMPENSATION

The CONTRACTOR and subcontractor will be required to accept liability for payment of all payroll taxes, sales and use tax, and all other taxes or deductions required by local, state or federal law. Each shall carry Workmen's Compensation Insurance to the full amounts as required by Statutes and shall include the cost of all foregoing items in the proposal. The CONTRACTOR will not otherwise be reimbursed or compensated for such tax payments. The CONTRACTOR is urged to ascertain at his own risk his actual tax liability in connection with the execution or performance of his Contract.

13. LAWS AND REGULATIONS

The bidder's attention is directed to the fact that all applicable state laws, municipal ordinances, and the rules and regulations of all authorities having jurisdiction over construction of the Project shall apply to the Contract throughout, and they will be deemed to be included in the contract, the same as though herein written out in full.

14. EROSION AND SEDIMENT CONTROL AND PERMITS

The CONTRACTOR and Subcontractors performing work on projects on behalf of the OWNER shall also comply with all applicable federal, state, and local environmental regulations and all requirements and conditions set forth in "special" permits including but not limited to Corp of Engineers 404 permits, 401 Water Quality Certifications, Stream Crossing and Floodplain Encroachment Permits as described in Part 4 General Conditions Paragraph 5.17.

15. PREVAILING WAGE LAW AND MINIMUM HOURLY RATES

Federal wage rates and regulations, if required for this Project, will be as described in the Special Conditions.

16. AFFIRMATIVE ACTION PLAN

The successful Bidder must submit the entire proposal with their bid, the following items to the Urban County Government:

1. Certification of Bid Proposal/DBE – see Part III
2. LFUCG MWDBE Participation Form – see Part III
3. Documentation Required for Good Faith Efforts and Outreach Plans – see Part III

A Work Force Analysis Form shall be submitted for each Contract. Failure to submit any of these items as required herein may result in disqualification of the Bidder from award of the Contract.

17. CONTRACT TIME

The number of calendar days within which the Work is to be substantially completed and ready for final payment (the Contract Time) is set forth in the Contract Agreement.

18. SUBSTITUTE OR "APPROVED EQUAL" ITEMS

The Contract, if awarded, will be on the basis of materials and equipment described in the Drawings or specified in the Specifications without consideration of possible substitute or "approved equal" items. Whenever it is indicated in the Drawings or specified in the Specifications that a substitute or "approved equal" item of material or equipment may be furnished or used by the CONTRACTOR if acceptable to the OWNER, application for such acceptance will not be considered by the OWNER until after the effective date of the Agreement. The procedure for submission of any such application by the CONTRACTOR and consideration by the OWNER is set forth in the General Conditions.

19. ALTERNATE BIDS

Bidders shall submit alternate bids/proposals only if and when such alternate bids/proposals have been specifically requested in an Invitation for Bids. If alternate bids/proposals are requested in an Invitation for Bids, the form of submission of such alternate bid and the conditions under which such alternate bids will be considered for award of a contract will be established in the Invitation.

Any Bidder who submits a bid incorporating an alternate proposal when alternate bids/proposals have not been requested in the Invitation for Bids shall have his/her bid rejected as non-responsive.

Any Bidder who submits a bid incorporating two (2) or more prices for an item or groups of items (unless such method of pricing is requested in the Invitation for Bids), or which imposes conditions for acceptance other than those established in the Invitation for Bids, shall have their bid rejected as non-responsive.

20. SIGNING OF AGREEMENT

When OWNER gives a Notice of Award to the successful Bidder, it will be accompanied by the required number of unsigned counterparts of the Agreement with all other written Contract Documents attached. Within ten days thereafter, CONTRACTOR shall sign and deliver the required number of counterparts of the Agreement and attached documents to OWNER with the required Bonds, Certificate of Insurance, and Power of Attorney. The OWNER will deliver one fully signed counterpart to CONTRACTOR at such time as it has been signed by the Mayor.

21. ASSISTANCE TO BE OFFERED TO DISADVANTAGED BUSINESS ENTERPRISE (MWDBE) CONTRACTORS AND VETERAN OWNED SMALL BUSINESSES

A. Outreach for MWDBE(s) and Veteran Owned Small Businesses (VOSB)

The Lexington-Fayette Urban County Government (LFUCG) maintains a database of MWDBE contractors and Veteran Owned Small Businesses. When a LFUCG construction project is advertised for bidding, notices are sent to companies registered at <https://lexingtonky.ionwave.net>. The notices describe the project and indicate the deadline for submitting bids.

If you wish to be added to the LFUCG MWDBE and Veteran contractor database, please contact:

Sherita Miller, MPA, CPSD
Minority Business Enterprise Liaison
Division of Procurement
Lexington-Fayette Urban County Government
200 East Main Street, Room 338
Lexington, Kentucky 40507
smiller@lexingtonky.gov

B. Bid Bond Assistance for MWDBE(s)

For those MWDBE contractors who wish to bid on LFUCG project, bid bond assistance is available. This bid bond assistance is in the form of a “Letter of Certification” which is accepted by the LFUCG’s Division of Purchasing, in lieu of a bid bond. The “Letter of Certification” must be included in the bid package when it is submitted to the Division of Purchasing. The “Letter of Certification” will reference the specific project for which the bid is being submitted, and the time and date on which the bid is due. Bid bond assistance must be requested from the Lexington-Fayette Urban County Government’s Division of Procurement.

C. Eligibility for Bid Bond Assistance for MWDBE(s)

In order to be eligible for any Bid bonding assistance, a MWDBE construction company must be owned or controlled at the level of 51% or more by a member or members of a minority group or females. Prior to receiving assistance, a statement providing evidence of ownership and control of the company by a member or members of a minority group or females must be signed by the Owner or corporate officer and by an attorney or accountant submitted to:

Sherita Miller, MPA, CPSD
Division of Procurement
Lexington-Fayette Urban County Government
200 East Main Street, Room 338
Lexington, Kentucky 40507
smiller@lexingtonky.gov
859-258-3323

D. MWDBE and VETERAN OWNED SMALL BUSINESSES (VOSB)

The LFUCG will, upon request, assist prime contractors in the procurement of eligible DBE subcontractors in an effort to achieve a seventeen percent (17%) minimum goal including minimum subgoals of five percent (5%) for Minority Business Enterprises (MBE) and a subgoal of twelve percent (12%) for Women Business Enterprises (WBE); a three (3%) minimum goal for Certified Veteran-Owned Small Businesses and/or Certified Service- Disabled Veteran Owned Businesses; and a goal of utilizing Disadvantaged Business Enterprises (DBE), where applicable, for government contracts.

For a list of eligible subcontractors, please contact:

Sherita Miller, MPA, CPSD
Minority Business Enterprise Liaison

Division of Procurement
Lexington-Fayette Urban County Government
200 East Main Street, Room 338
Lexington, Kentucky 40507
smiller@lexingtonky.gov
[859-258-3323](tel:859-258-3323)

22. LFUCG NON-APPROPRIATION CLAUSE

Contractor acknowledges that the LFUCG is a governmental entity, and the contract validity is based upon the availability of public funding under the authority of its statutory mandate.

In the event that public funds are unavailable and not appropriated for the performance of the LFUCG's obligations under this contract, then this contract shall automatically expire without penalty to the LFUCG thirty (30) days after written notice to Contractor of the unavailability and non-appropriation of public funds. It is expressly agreed that the LFUCG shall not activate this non-appropriation provision for its convenience or to circumvent the requirements of this contract, but only as an emergency fiscal measure during a substantial fiscal crisis, which affects generally its governmental operations.

In the event of a change in the LFUCG's statutory authority, mandate and mandated functions, by state and federal legislative or regulatory action, which adversely affects the LFUCG's authority to continue its obligations under this contract, then this contract shall automatically terminate without penalty to the LFUCG upon written notice to Contractor of such limitation or change in the LFUCG's legal authority.

23. NOTICE OF CONTENTION

Vendors who respond to this invitation have the right to file a notice of contention associated with the bid process or to file a notice of appeal of the recommendation made by the Director of Procurement resulting from this invitation.

Notice of contention with the bid process must be filed within 3 business days of the bid/proposal opening by (1) sending a written notice, including sufficient documentation to support contention, to the Director of the Division of Procurement or (2) submitting a written request for a meeting with the Director of Procurement to explain his/her contention with the bid process. After consulting with the Commissioner of Finance the Chief Administrative Officer and reviewing the documentation and/or hearing the vendor, the Director of Procurement shall promptly respond in writing findings as to the compliance with bid processes. If, based on this review, a bid process irregularity is deemed to have occurred the Director of Procurement will consult with the Commissioner of Finance, the Chief Administrative Officer and the Department of Law as to the appropriate remedy.

Notice of appeal of a bid recommendation must be filed within 3 business days of the bid recommendation by (1) sending a written notice, including sufficient documentation to support appeal, to the Director, Division of Procurement or (2) submitting a written request for a meeting with the Director of Procurement to explain the appeal. After reviewing the documentation and/or hearing the vendor and consulting with the Commissioner of Finance and the Chief Administrative Officer, the Director of Procurement shall in writing, affirm or withdraw the recommendation.

END OF SECTION

PART III

FORM OF PROPOSAL

INDEX

1.	FORM OF PROPOSAL	P-2
2.	LEGAL STATUS OF BIDDER.....	P-4
3	BIDDERS AFFIDAVIT	P-5
4.	BID SCHEDULE – SCHEDULE OF VALUES.....	P-6
5.	STATEMENT OF BIDDER'S QUALIFICATIONS	P-8
6.	LIST OF PROPOSED SUBCONTRACTORS	P-12
7.	LEXINGTON FAYETTE URBAN COUNTY GOVERNMENT MWDBE PARTICIPATION GOALS, FORMS, AND GOOD FAITH EFFORTS	P-14
8.	AUTHENTICATION OF BID AND STATEMENT OF NON-COLLUSION AND NON-CONFLICT OF INTEREST.....	P-25
9.	STATEMENT OF EXPERIENCE.....	P-26
10.	EQUAL OPPORTUNITY AGREEMENT.....	P-28
11.	EQUAL EMPLOYMENT OPPORTUNITY AFFIRMATIVE ACTION POLICY	P-32
12.	WORKFORCE ANALYSIS	P-33
13.	EVIDENCE OF INSURABILITY	P-34
14.	DEBARRED FIRMS.....	P-35
15.	DEBARRED CERTIFICATION	P-36

PART III

Invitation to Bid No. 33-2026

Concrete Tee Pads and Sign Posts for Disc Golf Course

1. FORM OF PROPOSAL

Place: Lexington, Kentucky

Date: 4/7/2026

The following Form of Proposal shall be followed exactly in submitting a proposal for this Work.

This Proposal Submitted by Davis H. Elliot Construction Company, Inc.

673 Blue Sky Parkway Lexington, KY 40509

(Name and Address of Bidding Contractor)

(Hereinafter called "Bidder"), organized and existing under the laws of the State of Virginia _____, doing business as Davis H. Elliot Construction Company, Inc.
Corporation _____ "a corporation," "a partnership", or an "individual" as applicable.

To: Lexington-Fayette Urban County Government
(Hereinafter called "OWNER")
Office of the Director of Purchasing
200 East Main Street, 3rd Floor
Lexington, KY 40507

Gentlemen:

The Bidder, in compliance with your Invitation for Bids for the **Concrete Tee Pads and Sign Posts for Disc Golf Course** having examined the Plans and Specifications with related documents, having examined the site for proposed Work, and being familiar with all of the conditions surrounding the construction of the proposed Project, including the availability of materials and labor, hereby proposes to furnish all labor, materials, and supplies, and to construct the Project in accordance with the Contract Documents, within the time set forth therein, and at the lump sum and/or unit prices stated hereinafter. These prices are to cover all expenses incurred in performing the Work required under the Contract Documents, of which this proposal is a part.

The Bidder hereby acknowledges receipt of the following addenda:

Addendum No. NONE Date _____

Addendum No. _____ Date _____

Addendum No. _____ Date _____

Addendum No. _____ Date _____

Addendum No. _____ Date _____

Addendum No. _____ Date _____

Addendum No. _____ Date _____

Addendum No. _____ Date _____

Insert above the number and the date of any Addendum issued and received. If none has been issued and received, the word "NONE" should be inserted.

2. LEGAL STATUS OF BIDDER

Bidder Davis H. Elliot Construction Company, Inc.

Date 4/7/2026

* 1. A corporation duly organized and doing business under the laws of the State of Virginia, for whom Julia E. Bellendir, bearing the official title of Vice President, whose signature is affixed to this Bid/Proposal, is duly authorized to execute contracts.

* 2. A Partnership, all of the members of which, with addresses are: (Designate general partners as such)

N/A

* 3. An individual, whose signature is affixed to this Bid/Proposal (please print name)

Julia E. Bellendir, Vice President

*(The Bidder shall fill out the appropriate form and strike out the other two.)

3.

BIDDERS AFFIDAVIT

Comes the Affiant, Julia E. Bellendir, and after being first duly sworn, states under penalty of perjury as follows:

1. His/her name is Julia E. Bellendir and he/she is the individual submitting the bid or is the authorized representative of Davis H. Elliot Construction Company, Inc. the entity submitting the bid (hereinafter referred to as "Bidder").
2. Bidder will pay all taxes and fees, which are owed to the Lexington-Fayette Urban County Government at the time the bid is submitted, prior to award of the contract and will maintain a "current" status in regard to those taxes and fees during the life of the contract.
3. Bidder will obtain a Lexington-Fayette Urban County Government business license, if applicable, prior to award of the contract.
4. Bidder has authorized the Division of Procurement to verify the above-mentioned information with the Division of Revenue and to disclose to the Urban County Council that taxes and/or fees are delinquent or that a business license has not been obtained.
5. Bidder has not knowingly violated any provision of Chapter 25 of the Lexington-Fayette Urban County Government Code of Ordinances, known as the "Ethics Act."
6. Bidder acknowledges that "knowingly" for purposes of this Affidavit means, with respect to conduct or to circumstances described by a statute or ordinance defining an offense, that a person is aware or should have been aware that his conduct is of that nature or that the circumstance exists.

Julia E. Bellendir
 Signature
Vice President
 Title

Julia E. Bellendir
 Printed Name
4/7/2026
 Date

Company Name Davis H. Elliot Construction Company, Inc.

Address 673 Blue Sky Parkway Lexington, KY 40509

Subscribed and sworn to before me by Julia E. Bellendir
 (Affiant)
 Vice President
 (Title)

of Davis H. Elliot Construction Company, Inc. this 7th day of April, 2026
 (Company Name)

Stephanie Lee Allen
 Notary Public
 [seal of notary] My commission expires: 11/12/2029



4. BID SCHEDULE – SCHEDULE OF VALUES

The Bidder agrees to perform all the Work described in the Specifications and shown on the Plans for the following proposed lump sum and/or unit prices, if applicable, which shall include the furnishing of all labor, materials, supplies, equipment and/or vehicle usage, services, all items of cost, overhead, taxes (federal, state, local), and profit for the Contractor and any Subcontractor involved, within the time set forth herein. If unit prices are applicable, Bidder must make the extensions and additions showing the total amount of bid.

If the unit price and the item total are illegible or are omitted, the bid may be determined nonresponsive. If a lump sum total price is illegible or is omitted, the bid may be determined nonresponsive.

For a unit price based bid, the sum of the item totals is the bid amount the Division uses for bid comparison.

The LFUCG’s decision on the bid amount is final.

Pricing should be submitted in line items tab on IonWave. Page P-7 must be fully executed and attached to bid submittal or bid will be considered non-responsive.

Item	Description	Unit
1	Construction of 28 disc golf concrete tee pads per specifications	LS
2	Provide and install 28 tee pad sign posts per specifications	LS
3	Provide and install 38 disc golf baskets per specifications	LS

Submitted by:

Davis H. Elliot Construction Company, Inc.

Firm

673 Blue Sky Parkway

Address

Lexington, KY 40509

City, State & Zip

***Bid must be signed:
(original signature)***

Julia E. Bellendir
Signature of Authorized Company Representative – Title

Julia E. Bellendir, Vice President

Representative/s Name (Typed or Printed)

859-263-5148 Ext: 2123

Area Code – Phone – Fax #

jbellendir@dhec.com

E-Mail Address

OFFICIAL ADDRESS:

673 Blue Sky Parkway

Lexington, KY 40509

(Seal if Bid is by Corporation)



By signing this form you agree to ALL terms, conditions, and associated forms in this bid package

5. **STATEMENT OF BIDDER'S QUALIFICATIONS**

The following statement of the Bidder's qualifications is required to be filled in, executed, and submitted with the Proposal:

1. Name of Bidder: Davis H. Elliot Construction Company, Inc.

2. Permanent Place of Business: 673 Blue Sky Parkway Lexington, KY 40509

3. When Organized: January 4th, 1946

4. Where Incorporated: Virginia Corporation

5. Construction Plant and Equipment Available for this Project:

1. 4X4 Pick-Up Truck

2. 12k Equipment and Material Trailer

3. Portable Cement Mixer

4. Mini Excavator

5. Skid Loader with Rake Attachment

(Attach Separate Sheet If Necessary)

6. Financial Condition:

If specifically requested by the OWNER, the apparent low Bidder is required to submit its latest three (3) years audited financial statements to the OWNER'S Division of Procurement within seven (7) calendar days following the bid opening.

7. In the event the Contract is awarded to the undersigned, surety bonds will be furnished by:

Hartford Fire Insurance Company (Surety)

Signed:  (Representative of Surety)
Alaine Nanette Drane

8. The following is a list of similar projects performed by the Bidder: (Attach separate sheet if necessary).

<u>NAME</u>	<u>LOCATION</u>	<u>CONTRACT SUM</u>
LG&E-KU Ford Plant	Louisville, KY	\$65,000.00
BREC - Sebree Substation	Paducah, KY	\$585,000.00
WRECC Wierhaeuser Sub	Bowling Green, KY	\$650,000.00

9. The Bidder has now under contract and bonded the following projects:

<u>NAME</u>	<u>LOCATION</u>	<u>CONTRACT SUM</u>
Davis H. Elliot Construction Company, Inc. has numerous bonded projects, a list can be provided upon award.		
Please see attached our bonding capacity letter.		

10. List Key Bidder Personnel who will work on this Project.

<u>NAME</u>	<u>POSITION DESCRIPTION</u>	<u>NO. OF YEARS WITH BIDDER</u>
Mark D. Corman	Division Manager	16 yrs
William Randy McGuffey	Operations Manager	18 yrs
Daron L. Fanakos	Construction Manager	16 yrs
Jon Sowder	General Foreman	6 yrs

11. DBE Participation on current bonded projects under contract:

SUBCONTRACTORS **PROJECT** **DBE** **% of WORK**
(LIST) **(SPECIFIC TYPE)**

Please see attached.

Vendor Name	Classification	Type of Business
AGE Engineering Services	SBE	Civil Engineering
Bluegrass Lighting	WBE	Electrical Supplies
Highway Safety Inc.	DBE	Traffic Control
Kimberly Inc.	DBE	Landscaping Subcontractor
Kinmar	WBE	Goods & Services
Mesa Associates	MBE-Nat Am	Engineering
MNJ Construction Services, LLC	SBE	Construction Contractor
Old Dominion Electric Supply	MBE-African	Supplies
P&C Prime LLC	VET	Safety/Materials
Shepaul Enterprises	DBE	Guardrails/Fencing
Stoner Creek Welding & Fabrication	SBE	Equipment Repairs
Terradon Corporation	WBE	Engineering
The Crane Mat Company	VET	Crane Mats
The Fishel Company	WBE	Engineering
TKM, Inc.	DBE	Excavation Contractor
Toni Levy & Associates (DBA Levy's construction and Building)	WBE	Materials
Tyndale Enterprises, Inc.	WBE	FR Clothing
Wil-Mar Hydraulics & Machine	WBE	Equipment Repairs
Xpress Management Solutions	MBE-African	Fuel, Lodging, Rentals, Shipping, Custodial Services

12. We acknowledge that, if we are the apparent low Bidder, we will submit to the OWNER within 7 calendar days following the Bid Opening, a sworn statement on the OWNER'S form regarding all current work on hand and under contract, and a statement on the OWNER'S form of the experience of our officers, office management and field management personnel. Additionally, if requested by the OWNER, we will within 7 days following the request submit audited financial statements and loss history for insurance claims for the 3 most recent years (or a lesser period stipulated by the OWNER)—all in accordance with the Bid Documents.

Respectfully submitted:

Davis H. Elliot Construction Company, Inc.
(Name of Contracting Firm)

BY: 
Julia E. Bellendir

TITLE: Vice President

DATE 4/7/2026

6. LIST OF PROPOSED SUBCONTRACTORS

The following list of proposed subcontractors is required by the OWNER to be executed, completed and submitted with the BIDDER'S FORM OF PROPOSAL. All subcontractors are subject to approval of the Lexington-Fayette Urban County Government. Failure to submit this list completely filled out may be cause for rejection of bid.

<u>BRANCH OF WORK-LIST</u>	<u>DBE</u>	<u>% of EACH MAJOR ITEM</u>
		Work

None Anticipated.

LIST OF MATERIALS/ SUPPLIERS

Bidders are hereby advised that this list must be complete and submitted with the Bid.

Listing "as per plans and specifications", will not be considered as sufficient identification. Where more than one "Make or Brand" is listed for any one item, the Owner has the right to select the one to be used.

Item	Brand Name, Manufacturer and/or Supplier
Item #3, Disc Golf Brackets	MVP Disc Sport; Black Hole, Portal Edition



LEXINGTON

MINORITY BUSINESS ENTERPRISE PROGRAM

Sherita Miller, MPA, CPSD
Minority Business Enterprise Liaison
Division of Procurement
Lexington-Fayette Urban County Government
200 East Main Street
Lexington, KY 40507
smiller@lexingtonky.gov
859-258-3323

OUR MISSION: The mission of the Minority Business Enterprise Program (MBEP) is to facilitate the full participation of minority and women owned businesses in the procurement process and to promote economic inclusion as a business imperative essential to the long-term economic viability of Lexington-Fayette Urban County Government.

To that end the urban county council adopted and implemented Resolution 272-2024 – a Certified Minority and Women Business Enterprise seventeen percent (17%) minimum goal including minimum subgoals of five percent (5%) for Minority Business Enterprises (MBE) and a subgoal of twelve percent (12%) for Women Business Enterprises (WBE); a three (3%) minimum goal for Certified Veteran-Owned Small Businesses and/or Certified Service- Disabled Veteran Owned Businesses; and a goal of utilizing Disadvantaged Business Enterprises (DBE), where applicable, for government contracts.

The resolution states the following definitions shall be used for the purposes of reaching these goals:

Certified Disadvantaged Business Enterprise (DBE) – a business in which at least fifty-one percent (51%) is owned, managed and controlled by a person(s) who is socially and economically disadvantaged as define by 49 CFR subpart 26.

Certified Minority Business Enterprise (MBE) – a business in which at least fifty-one percent (51%) is owned, managed and controlled by an ethnic minority (i.e. Black American, Asian American, Hispanic American, Native American)

Certified Women Business Enterprise (WBE) – a business in which at least fifty-one percent (51%) is owned, managed and controlled by a woman.

Certified Veteran-Owned Small Business (VOSB) – a business in which at least fifty-one percent (51%) is owned, managed and controlled by a veteran who served on active duty with the U.S. Army, Air Force, Navy, Marines or Coast Guard.

Certified Service -Disabled Veteran Owned Small Business (SDVOSB) – a business in which at least fifty-one percent (51%) is owned, managed and controlled by a disabled veteran who served on active duty with the U.S. Army, Air Force, Navy, Marines or Coast Guard.

The term “Certified” shall mean the business is appropriately certified, licensed, verified, or validated by an organization or entity recognized by the Division of Procurement as having the appropriate credentials to make a determination as to the status of the business.

The following certifications are recognized and accepted by the MBEP:

Kentucky Transportation Cabinet (KYTC), Disadvantaged Business Enterprise (DBE)
Kentucky Minority and Women Business Enterprise (MWBE)
Women’s Business Enterprise National Council (WBENC)
National Women Business Owners Corporation (NWBOC)
National Minority Supplier Development Council (NMSDC)
Tri-State Minority Supplier Development Council (TSMSSDC)
U.S. Small Business Administration Veteran Small Business Certification (VetCert)
Kentucky Service- Disabled Veteran Owned Small Business (SDVOSB)

To comply with Resolution 272-2024, prime contractors, minority and women business enterprises, veteran owned small businesses, and service-disabled veteran owned small businesses must complete monthly contract compliance audits in the Diverse Business Management Compliance system, <https://lexingtonky.diversitycompliance.com/>

A list of organizations that certify and/or maintain lists of certified businesses (i.e. DBE, MBE, WBE, VOSB and/or SDVOSB) is available upon request by emailing, Sherita Miller, smiller@lexingtonky.gov.



LEXINGTON

LFUCG MWDBE PARTICIPATION FORM

Bid/RFP/Quote Reference # _____

Concrete Tee Posts and Sign Posts for Disc Golf Course
Bid No. 11-2026

The MWDBE and/or veteran subcontractors listed have agreed to participate on this Bid/RFP/Quote. If any substitution is made or the total value of the work is changed prior to or after the job is in progress, it is understood that those substitutions must be submitted to the Division of Procurement for approval immediately. **Failure to submit a completed form may cause rejection of the bid.**

MWBE Company, Name, Address, Phone, Email	DBE/MBE WBE/VOSB/SDVOSB	Work to be Performed	Total Dollar Value of the Work	% Value of Total Contract
1. None Anticipated.				
2.				
3.				
4.				

The undersigned company representative submits the above list of MDWBE and veteran firms to be used in accomplishing the work contained in this Bid/RFP/Quote. Any misrepresentation may result in the termination of the contract and/or be subject to applicable Federal and State laws concerning false statements and false claims.

Davis H. Elliot Construction Company, Inc.

Company

4/7/2026

Date

Company Representative Julia E. Bellendir

Vice President

Title



LEXINGTON

LFUCG MWDBE SUBSTITUTION FORM

Concrete Tee Pads and Sign Posts for Disc Golf Course
Bid No. 33-2026

Bid/RFP/Quote Reference # _____

The substituted MWDBE and/or veteran subcontractors listed below have agreed to participate on this Bid/RFP/Quote. These substitutions were made prior to or after the job was in progress. These substitutions were made for reasons stated below and are now being submitted to the Division of Procurement for approval. By the authorized signature of a representative of our company, we understand that this information will be entered into our file for this project. **Note: Form required if a subcontractor is being substituted on a contract.**

SUBSTITUTED DBE/MBE/WBE/VOSB Company Name, Address, Phone, Email	DBE/MBE/WBE/VOSB/SDVOSB Formally Contracted/ Name, Address, Phone, Email	Work to Be Performed	Reason for the Substitution	Total Dollar Value of the Work	% Value of Total Contract
1. Form acknowledged. Please see the attached.					
2.					
3.					
4.					

The undersigned acknowledges that any misrepresentation may result in termination of the contract and/or be subject to applicable Federal and State laws concerning false statements and false claims.

Davis H. Elliot Construction Company, Inc.

Company

4/7/2026

Date

Company Representative Julia E. Bellendir

Vice President

Title



LEXINGTON

DOCUMENTATION REQUIRED FOR GOOD FAITH EFFORTS AND OUTREACH PLANS

As affirmed in Resolution Number 272-2024, the Urban County Council has adopted an annual aspirational goal of utilizing at least seventeen percent (17%) of public funds spend from certain discretionary agreements with certified Minority Business Enterprises (MBEs) and certified Woman Business Enterprises (WBEs); utilizing at least three percent (3%) of public funds from certain discretionary agreements with Certified Veteran-Owned Small Business and Certified Service-Disabled Veteran-Owned Small Businesses (VOSBs); and utilizing Disadvantaged Business Enterprises (DBEs) where applicable. Bidders should make every effort to achieve these goals.

Therefore, as an element of the responsiveness of the bid, all Bidders are required to submit documentation of their good faith and outreach efforts to ensure all businesses, including small and disadvantaged businesses such as minority-, woman-, and veteran-owned businesses, have an equal opportunity to compete for and participate in the performance of any subcontracts resulting from this procurement. Examples of good faith and outreach efforts that satisfy this requirement to encourage the participation of, DBEs, MBEs, WBEs, VOSBs and/or SDVOSBs include:

1. Advertised opportunities to participate in the contract in at least two (2) publications of general circulation media; trade and professional association publications; small and minority business or trade publications; and publications or trades targeting minority, women, and disadvantaged businesses not less than fifteen (15) days prior to the deadline for submission of bids to allow, DBEs, MBEs, WBEs, VOSBs and/or SDVOSBs to participate.
2. Attended LFUCG Procurement Economic Inclusion Outreach event(s) within the past year to meet new small businesses, DBEs, MBEs, WBEs, VOSBs and/or SDVOSBs to partner with on LFUCG contracts and procurements.
3. Attended pre-bid/pre-proposal meetings that were scheduled by LFUCG to inform small businesses, DBEs, MBEs, WBEs, VOSBs and/or SDVOSBs of subcontracting opportunities.
4. Sponsored Economic Inclusion event to provide networking opportunities for prime contractors and small businesses, DBEs, MBEs, WBEs, VOSBs and/or SDVOSBs.
5. Requested a list of certified small, DBE, MBE, WBE, VOSB and/or SDVOSB subcontractors or suppliers from LFUCG and showed evidence of contacting the companies on the list(s).
6. Contacted organizations that work with small, DBE, MBE, WBE, and VOSB companies for assistance in finding certified DBEs, MBEs, WBEs, VOSB and/or SDVOSBs to work on this project. Those contacted and their responses must be a part of the bidder's outreach efforts documentation.

7. Sent written notices, by certified mail, email, or facsimile, to qualified, certified small businesses, DBEs, MBEs, WBEs, VOSBs and/or SDVOSBs soliciting their participation in the contract not less than seven (7) days prior to the deadline for submission of bids to allow them to participate effectively.
8. Followed up initial solicitations by contacting small businesses, DBEs, MBEs, WBEs, VOSBs and/or SDVOSBs via tailored communications to determine their level of interest.
9. Provided the interested small businesses, DBEs, MBEs, WBEs, VOSBs and/or SDVOSBs with adequate and timely information about the plans, specifications, and requirements of the contract.
10. Selected portions of the work to be performed by small businesses, DBEs, MBEs, WBEs, VOSBs and/or SDVOSBs in order to increase the likelihood of subcontracting participation. This includes, where appropriate, breaking out contract work items into economically feasible units to facilitate small, DBE, MBE, WBE, VOSB and/or SDVOSB participation, even when the prime contractor may otherwise perform these work items with its own workforce.
11. Negotiated in good faith with interested small businesses, DBEs, MBEs, WBEs, VOSBs and/or SDVOSBs, not rejecting them as unqualified without sound reasons based on a thorough investigation of their capabilities. Any rejection must be so noted in writing with a description as to why an agreement could not be reached.
12. Included documentation of quotations received from interested small businesses, DBEs, MBEs, WBEs, VOSBs and/or SDVOSBs that were not used due to uncompetitive pricing or were rejected as unacceptable and/or copies of responses from firms indicating that they would not be submitting a bid.
 - a. Bidder has to submit sound reasons why the quotations were considered unacceptable. The fact that the bidder has the ability and/or desire to perform the contract work with its own forces will not be considered a sound reason for rejecting a small business', DBE's MBE's, WBE's, VOSB's and/or SDVOSB's quote. Nothing in this provision shall be construed to require the bidder to accept unreasonable quotes in order to satisfy the participation goals.
13. Made an effort to offer assistance to or refer interested small businesses, DBEs, MBEs, WBEs, VOSBs and/or SDVOSBs to obtain the necessary equipment, supplies, materials, insurance and/or bonding to satisfy the work requirements of the bid proposal.
14. Made efforts to expand the search for small businesses, DBEs, MBEs, WBEs, VOSBs and/or SDVOSBs beyond the usual geographic boundaries.

15. Other – any other evidence that the bidder submits that may demonstrate that the bidder has made reasonable efforts to include small, DBE, MBE, WBE, VOSB and/or SDVOSB participation.

Bidder must document, with specificity, each of the efforts it made to include small businesses, DBEs, MBEs, WBEs, VOSBs and/or SDVOSBs as subcontractors in the procurement, including the date on which each effort was made, the medium through which each effort was made, and the outcome of each effort.

Note: Failure to submit the documentation requested in this section may be cause for rejection of bid. Bidders may include any other documentation deemed relevant to this requirement which is subject to review by the MBE Liaison. Documentation of Good Faith and Outreach Efforts must be submitted with the Bid, regardless of the proposed level of small, DBE, MBE, WBE, VOSB and/or SDVOSB participation in the procurement. If the Good Faith and Outreach Effort documentation is not submitted with the bid response, the bid may be rejected.

OUTREACH EFFORTS EVALUATION

Outreach efforts demonstrated by the bidder or respondent will be evaluated on a pass/fail basis.

ATTACHMENT A – SMALL AND DISADVANTAGED, MINORITY-, WOMEN-, AND VETERAN-OWNED BUSINESS OUTREACH PLAN

Proposer Name: <u>Davis H. Elliot Construction Company, Inc.</u>	Date: <u>4/7/2026</u>
Project Name: <u>Concrete Tee Pads and Sign Posts for Disc Golf Course</u>	Project Number: <u>Bid No. 33-2026</u>
Contact Name: <u>Julia E. Bellendir</u>	Telephone: <u>859-263-5148 Ext: 2123</u>
Email: <u>jbellendir@dhec.com</u>	

The mission of the Minority Business Enterprise Program is to facilitate the full participation of disadvantaged businesses, minority-, women-, veteran-, and service-disabled veteran-owned businesses in the procurement process and to promote economic inclusion as a business imperative essential to the long-term economic viability of Lexington-Fayette Urban County Government.

To that end, small and disadvantaged businesses, including minority-, woman-, veteran-, and service-disabled veteran-owned businesses, must have an equal opportunity to be utilized in the performance of contracts with public funds spent from certain discretionary agreements. By submitting its offer, Bidder/Proposer certifies that it has taken, and if there are further opportunities will take, reasonable steps to ensure that small and disadvantaged businesses, including minority-, woman-, veteran-, and service-disabled veteran-owned businesses, are provided an equal opportunity to compete for and participate in the performance of any subcontracts resulting from this procurement.

The information submitted in response to this clause will not be considered in any scored evaluation. Failure to submit this form may cause the bid or proposal to be rejected.

Is the Bidder/ Proposer a certified firm? Yes No

If yes, indicate all certification type(s):

DBE MBE WBE SBE VOSB/SDVOSB

and supply a copy of the certificate and/or certification letter if not currently listed on the city’s Minority Business Enterprise Program’s (MBEP) certified list.

1. Include a list of firms that Bidder/ Proposer has had a contractual relationship with within the last two years that are minority-owned, woman-owned, veteran-owned or small businesses, regardless of their certification status. Please see attached subcontractor and supplier diversity letter.

(Click or tap here to enter text.)

2. Does Bidder/Proposer foresee any subcontracting opportunities for this procurement?

Yes No

If no, please explain why in the field below. Do not complete the rest of this form and submit this first page with your bid and/or proposal. (Click or tap here to enter text.) Please see attached subcontractor and supplier diversity letter.

If yes, please complete the following pages and submit all pages with your bid and/or proposal.

Describe the steps Bidder/Proposer took to solicit small and disadvantaged businesses, including MBEs, WBEs, VOSBs, and SDVOSBs, for subcontracting opportunities for this procurement.

3. Check the good faith and outreach efforts the Bidder/Proposer used to encourage the participation of small and disadvantaged businesses including, MBEs, WBEs, VOSBs and SDVOSBs:

- Bidder placed advertisements in search of prospective small businesses, DBEs, MBEs, WBEs, VOSBs and/or SDVOSBs for the solicitation.
- Bidder attended LFUCG Procurement Economic Inclusion Outreach event(s) within the past year.
- Bidder attended pre-bid and/or pre-proposal meetings for this solicitation.
- Bidder sponsored an Economic Inclusion Outreach event.
- Bidder requested a list of certified small, DBE, MBE, WBE, VOSB and/or SDVOSB subcontractors or suppliers from LFUCG.
- Bidder contacted organizations that work with small, DBE, MBE, WBE, VOSB and/or SDVOSB companies.
- Bidder sent written notices to certified small, DBE, MBE, WBE, VOSB and SDVOSB businesses.
- Bidder followed up to initial solicitations with interested small, DBE, MBE, WBE, VOSB and/or SDVOSB.
- Bidder provided small, DBE, MBE, WBE, VOSB and/or SDVOSB businesses interested in performing the solicited work with prompt access to the plans, specifications, scope of work, and requirements of the solicitation.
- Bidder made efforts to segment portions of the work to be performed by small businesses, DBEs, MBEs, WBEs, VOSBs and/or SDVOSBs, including dividing sub-bid/partnership opportunities into economically feasible units/parcels, to facilitate participation.

- Bidder negotiated in good faith with interested small, DBE, MBE, WBE, VOSB and/or SDVOSB businesses.
- Bidder provided adequate rationale for rejecting any small business', DBEs, MBEs, WBEs, VOSBs or SDVOSBs for lack of qualifications.
- Bidder offered assistance in obtaining bonding, insurance, financial, equipment, or other resources to small businesses, DBEs, MBEs, WBEs, VOSBs and/or SDVOSBs, in an effort to assist them in meeting project requirements.
- Bidder made efforts to expand the search for small businesses, DBEs MBEs, WBEs, VOSBs and/or SDVOSBs beyond the usual geographic boundaries.
- Bidder made other reasonable efforts to include small businesses, DBEs, MBEs, WBEs, VOSBs and/or SDVOSBs participation.

4. Bidder/Proposer must include documentation, including the date each effort was made, the medium through which each effort was made, and the outcome of each effort with this form, regardless of the level of small, DBE, MBE, WBE, VOSB and/or SDVOSB participation. Examples of required documentation include copies of email communications, copies of newspaper advertisements, or copies of quotations received from interested small businesses, DBEs, MBEs, WBEs, VOSBs or SDVOSBs.

Please see attached subcontractor and supplier diversity letter.

« (Click or tap here to enter text.) »

For detailed information regarding outreach efforts that satisfy the MBE Program's requirements, please see "Documentation Required for Good Faith Efforts and Outreach Plans" page.

Note: The Bidder/Proposer must be willing to report the identity of each subcontractor and the value of each subcontract to MBEP if awarded a contract from this procurement.

Failure to submit the documentation requested may be cause for rejection of the bid. Bidders may include any other documentation deemed relevant to this requirement, which is subject to review by the MBE Liaison. Documentation of Good Faith and Outreach Efforts must be submitted with the bid, regardless of the proposed level of SBEs, DBEs, MBEs, WBEs, VOSBs and/or SDVOSBs participation in the procurement. If the Good Faith and Outreach Effort Form and associated documentation is not submitted with the bid response, the bid may be rejected.

The undersigned acknowledges that all information is accurate. Any misrepresentations may result in termination of the contract and/or be subject to applicable Federal and State laws concerning false statements and claims.

Davis H. Elliot Construction Company, Inc.

Company

4/7/2026

Date



Company Representative Julia E. Bellendir

Vice President

Title

4870-1925-6809, v. 1

8. **AUTHENTICATION OF BID AND STATEMENT OF NON-COLLUSION, NON-CONFLICT OF INTEREST**

I hereby swear (or affirm) under the penalty for false swearing:

1. That I am the Bidder (if the Bidder is an individual), a partner of the Bidder (if the Bidder is a partnership), or an officer or employee of the bidding corporation having authority to sign on its behalf (if the Bidder is a corporation);
2. That the attached bid has been arrived at by the Bidder independently, and has been submitted without collusion with, and without any agreement, understanding or planned common course of action, with any other contractor, vendor of materials, supplies, equipment or services described in the Invitation to Bid, designed to limit independent bidding or competition;
3. That the contents of the bid or bids have not been communicated by the Bidder or its employees or agents to any person not an employee or agent of the Bidder or its surety on any bond furnished, with the bid or bids, and will not be communicated to any such person, prior to the official opening of the bid or bids;
4. That the Bidder is legally entitled to enter into the contracts with the Lexington-Fayette Urban County Government, and is not in violation of any prohibited conflict of interest;
5. (Applicable to corporation only) That as a foreign corporation, we are registered with the Secretary of State, Commonwealth of Kentucky, and authorized to do business in the State or, that as a domestic corporation, we are in good standing with the Secretary of State, Commonwealth of Kentucky _____. Check the statement applicable.
6. This offer is for 60 calendar days from the date this bid is opened. In submitting the above, it is expressly agreed that, upon proper acceptance by the Lexington-Fayette Urban County Government of any or all items bid above, a contract shall thereby be created with respect to the items accepted.
7. That I have fully informed myself regarding the accuracy of the statements made in this statement.
8. That I certify that Subcontractors have not and will not be awarded to any firm(s) that have been debarred from noncompliance with the Federal Labor Standards, Title VI of the Civil Rights Act of 1964 As Amended, Executive Order 11246 As Amended or any other Federal Law.

9. STATEMENT OF EXPERIENCE

NAME OF INDIVIDUAL: Julia E. Bellendir

POSITION/TITLE: Vice President

STATEMENT OF EXPERIENCE: Please see attached.

NAME OF INDIVIDUAL: Mark D. Corman

POSITION/TITLE: Division Manager

STATEMENT OF EXPERIENCE: Please see attached.

NAME OF INDIVIDUAL: William Randy McGuffey

POSITION/TITLE: Operations Manager

STATEMENT OF EXPERIENCE: Please see attached.

NAME OF INDIVIDUAL: Daron L. Fanakos

POSITION/TITLE: Construction Manager

STATEMENT OF EXPERIENCE: Please see attached.

NAME OF INDIVIDUAL: Jon Sowder

POSITION/TITLE: General Foreman

STATEMENT OF EXPERIENCE: Please see attached.

NAME OF INDIVIDUAL: _____

POSITION/TITLE: _____

STATEMENT OF EXPERIENCE: _____

* Include all officers, office management's, Affirmative Action officials, and field management personnel. (Attach separate sheets if necessary.)

10. EQUAL OPPORTUNITY AGREEMENT

Standard Title VI Assurance

The Lexington Fayette-Urban County Government, (hereinafter referred to as the “Recipient”) hereby agrees that as a condition to receiving any Federal financial assistance from the U.S. Department of Transportation, it will comply with Title VI of the Civil Rights Act of 1964, 78Stat.252, 42 U.S.C. 2000d-4 (hereinafter referred to as the “Act”), and all requirements imposed by or pursuant to Title 49, Code of Federal Regulations, U.S. Department of Transportation, Subtitle A, Office of the Secretary, (49 CFR, Part 21) Nondiscrimination in Federally Assisted Program of the Department of Transportation – Effectuation of Title VI of the Civil Rights Act of 1964 (hereinafter referred to as the “Regulations”) and other pertinent directives, no person in the United States shall, on the grounds of race, color, national origin, sex, age (over 40), religion, sexual orientation, gender identity, veteran status, or disability be excluded from participation in, be denied the benefits of, or be otherwise subjected to discrimination under any program or activity for which the Recipient receives Federal financial assistance from the U.S. Department of Transportation, including the Federal Highway Administration, and hereby gives assurance that will promptly take any necessary measures to effectuate this agreement. This assurance is required by subsection 21.7(a) (1) of the Regulations.

The Law

- * Title VII of the Civil Rights Act of 1964 (amended 1972) states that it is unlawful for an employer to discriminate in employment because of race, color, religion, sex, age (40-70 years) or national origin.
- * Executive Order No. 11246 on Nondiscrimination under Federal contract prohibits employment discrimination by contractor and subcontractor doing business with the Federal Government or recipients of Federal funds. This order was later amended by Executive Order No. 11375 to prohibit discrimination on the basis of sex.
- * Section 503 of the Rehabilitation Act of 1973 States:
The Contractor will not discriminate against any employee or applicant for employment because of physical or mental handicap.
- * Section 2012 of the Vietnam Era Veterans Readjustment Act of 1973 requires Affirmative Action on behalf of disabled veterans and veterans of the Vietnam Era by contractors having Federal Contracts.
- * Section 206 (A) of Executive Order 12086, Consolidation of Contract Compliance Functions for Equal Employment Opportunity, states:
The Secretary of Labor may investigate the employment practices of any Government contractor or sub-contractor to determine whether or not the contractual provisions specified in Section 202 of this order have been violated.

The Lexington-Fayette Urban County Government practices Equal Opportunity in recruiting, hiring and promoting. It is the Government's intent to affirmatively provide employment opportunities for those individuals who have previously not been allowed to enter into the mainstream of society. Because of its importance to the local Government, this policy carries the full endorsement of the Mayor, Commissioners, Directors, and all supervisory personnel. In following this commitment to Equal Employment Opportunity and because the Government is the benefactor of the Federal funds, it is both against the Urban County Government policy and illegal

for the Government to let contracts to companies which knowingly or unknowingly practice discrimination in their employment practices. Violation of the above mentioned ordinances may cause a contract to be canceled and the contractor may be declared ineligible for future consideration.

Please sign this statement in the appropriate space acknowledging that you have read and understand the provisions contained herein. Return this document as part of your application packet.

Bidders

I/We agree to comply with the Civil Rights Laws listed above that govern employment rights of minorities, women, Vietnam veterans, handicapped, and aged persons.

Signature Julia E. Bellendir, Vice President

Davis H. Elliot Construction Company, Inc.
Name of Business

The Entity (regardless of whether construction contractor, non-construction contractor or supplier) agrees to provide equal opportunity in employment for all qualified persons, to prohibit discrimination in employment because of race, color, religion, sex (including pregnancy, sexual orientation or gender identity), national origin, disability, age, genetic information, political affiliation, or veteran status, and to promote equal employment through a positive, continuing program from itself and each of its sub-contracting agents. This program of equal employment opportunity shall apply to every aspect of its employment policies and practices.

The Kentucky equal Employment Opportunity Act of 1978 (KRS 45.560-45.640) requires that any count, city, town, school district, water district, hospital district, or other political subdivision of the state shall include in directly or indirectly publicly funded contracts for supplies, materials, services, or equipment hereinafter entered into the following provisions:

During the performance of this contract, the contractor agrees as follows:

- (1) *The contractor will not discriminate against any employee or applicant for employment because of race, color, religion, sex, age or national origin;*
- (2) *The contractor will state in all solicitations or advertisements for employees placed by or on behalf of the contractors that all qualified applicants will receive consideration for employment without regard to race, color, religion, sex, age or national origin;*
- (3) *The contract will post notices in conspicuous places, available to employees and applicants for employment, setting forth the provisions of the non-discrimination clauses required by this section; and*
- (4) *The contractor will send a notice to each labor union or representative of workers with which he has a collective bargaining agreement or other contract or understanding advising the labor union or workers' representative of the contractor's commitments under the nondiscrimination clauses.*

The Act further provides:

KRS 45.610. Hiring minorities – Information required

- (1) *For the length of the contract, each contractor shall hire minorities from other sources within the drawing area, should the union with which he has collective bargaining agreements be unwilling to supply sufficient minorities to satisfy the agreed upon goals and timetable.*
- (2) *Each contractor shall, for the length of the contract, furnish such information as required by KRS 45.560 to KRS 45.640 and by such rules, regulations and orders issued pursuant thereto and will permit access to all books and records pertaining to his employment practices and work sites by the contracting agency and the department for purposes of investigation to ascertain compliance with KRS 45.560 to 45.640 and such rules, regulations and orders issued pursuant thereto.*

KRS 45.620. Action against contractor – Hiring of minority contractor or subcontractor

- (1) *If any contractor is found by the department to have engaged in an unlawful practice under this chapter during the course of performing under a contract or subcontract covered under KRS 45.560 to 45.640, the department shall so certify to the contracting agency and such certification shall be binding upon the contracting agency unless it is reversed in the course of judicial review.*
- (2) *If the contractor is found to have committed an unlawful practice under KRS 45.560 to 45.640, the contracting agency may cancel or terminate the contract, conditioned upon a program for future compliance approved by the contracting agency and the department. The contracting agency may declare such a contractor ineligible to bid on further contracts with that agency until such time as the contractor complies in full with the requirements of KRS 45.560 – 45.640.*
- (3) *The equal employment provisions of KRS 45.560 to 45.640 may be met in part by a contractor by subcontracting to a minority contractor or subcontractor. For the provisions of KRS 45.560 to 45.640, a minority contractor or subcontractor shall mean a business that is owned and controlled by one or more persons disadvantaged by racial or ethnic circumstances.*

KRS 45.630 Termination of existing employee not required, when

Any provision of KRS 45.560 to 45.640 notwithstanding, no contractor shall be required to terminate an existing employee upon proof that that employee was employed prior to the date of the contract.

KRS 45.640 Minimum skills

Nothing in KRS 45.560 to 45.640 shall require a contractor to hire anyone who fails to demonstrate the minimum skills required to perform a particular job.

It is recommended that all of the provisions quoted above to be included as special conditions in each contract. In the case of a contract exceeding \$250,000, the contractor is required to furnish evidence that his work-force in Kentucky is representative of the available work-force in the area from which he draws employees, or to supply an Affirmative Action plan which will achieve such representation during the life of the contract.

11. **EQUAL EMPLOYMENT OPPORTUNITY AFFIRMATIVE ACTION POLICY**

It is the policy of Davis H. Elliot Construction Company, Inc.

to assure that all applicants for employment and all employees are treated on a fair and equitable basis without regard to their race, religion, sex, color, handicap, natural origin or age.

Such action shall include employment, promotion, demotion, recruitment or recruitment advertising, layoff or termination, rates of pay and other forms of compensation, and selection for training, whether apprenticeship and/or on-the-job-training.

Furthermore, this company agrees to make special recruitment efforts to hire the protected class whenever feasible. This company also agrees to adhere to all applicable federal, state, and local laws relating to Equal Employment Opportunity for all individuals.

WORKFORCE ANALYSIS FORM

Name of Organization: Davis H. Elliot Construction Company, Inc.

Categories	Total	White (Not Hispanic or Latino)		Hispanic or Latino		Black or African-American (Not Hispanic or Latino)		Native Hawaiian and Other Pacific Islander (Not Hispanic or Latino)		Asian (Not Hispanic or Latino)		American Indian or Alaskan Native (not Hispanic or Latino)		Two or more races (Not Hispanic or Latino)		Total	
		M	F	M	F	M	F	M	F	M	F	M	F	M	F	M	F
Administrators	75	71	1									3				74	1
Professionals	123	90	19	3	1	1				1	2	1	2	2	1	98	25
Superintendents																	
Supervisors																	
Foremen																	
Technicians <small>semi skilled operatives</small>	283	197	11	34	1	5	2	1				21		13		271	12
Protective Service																	
Para-Professionals																	
Office/Clerical	114	47	58	1		2						1	1	1	3	52	62
Skilled Craft	2737	2422	24	103		29		2		2		82	2	70	1	2710	27
Service/Maintenance <small>Laborers (unskilled)</small>	162	142	10	1		3						2		4		152	10
Total:	3494	2969	121	142	2	40	2	3		3	2	110	5	90	5	3357	137

Prepared by: 
 (Name and Title) Julia Bellendir, Vice President

Date: 4 / 7 / 2026

Revised 2015-Dec-15

13. EVIDENCE OF INSURABILITY

LEXINGTON-FAYETTE URBAN COUNTY GOVERNMENT CONSTRUCTION PROJECT
(Use separate form for each Agency or Brokerage agreeing to provide coverage)

Names Insured: Davis H. Elliot Construction Co., Inc. Employee ID: _____
 Address: PO Box 12108, Lexington, KY Phone: _____
 Project to be insured: 33-2026

In lieu of obtaining certificates of insurance at this time, the undersigned agrees to provide the above Named Insured with the minimum coverage listed below. These are outlined in the Insurance and Risk Management of Part V (Special Conditions), including all requirements, and conditions:

Section Items	Coverage	Minimum Limits and Policy Requirements	Limits Provided To Insured	Name of Insurer	A.M. Best's	
					Code	Rating
SC-2 – see provisions	CGL	\$1,000,000 per occ. And \$2,000,000 aggregate	\$1,000,000 Occurrence \$2,000,000 Aggregate	The Travelers Indemnity Company	002520	A++
SC-2 – see provisions	AUTO	\$1,000,000/per occ.	\$2,000,000 Combined Single Limit	The Travelers Indemnity Company	002520	A++
SC-2 – see provisions	WC / EL	Statutory w /endorsement as noted / \$100,000	\$ Statutory	Travelers Casualty Company of Connecticut	011024	A++
SC-2 – see provisions	EXC	\$1,000,000 per occ.	\$5,000,000 Occurrence/Aggregate	Travelers Property Casualty Company of America	004461	A++

Section 2 includes required provisions, statements regarding insurance requirements, and the undersigned agrees to abide by all provisions for the coverage's checked above unless stated otherwise when submitting.

Scott Insurance
 Agency or Brokerage
1301 Old Graves Mill Rd
 Street Address
Lynchburg, VA 24502
 City State Zip
434-832-2184
 Telephone Number

Lori Ohannessian
 Name of Authorized Representative
Commercial Account Manager
 Title

 Authorized Signature
3/27/2026
 Date

NOTE: Authorized signatures may be the agent's if agent has placed insurance through an agency agreement with the insurer. If insurance is brokered, authorized signature must be that of authorized representative of insurer.

IMPORTANT: Contract may not be awarded if a completed and signed copy of this form for all coverage's listed above is not provided with the bid.

14. DEBARRED FIRMS

PROJECT NAME: Concrete Tee Pads and Sign Posts for Disc Golf Course

BID NUMBER: Bid No. 33-2026

**LEXINGTON-FAYETTE URBAN COUNTY GOVERNMENT
LEXINGTON, KY**

All prime Contractors shall certify that Subcontractors have not and will not be awarded to any firms that has been debarred for noncompliance with the Federal Labor Standards, Title VI of the Civil Rights Act of 1964 As Amended, Executive Order 11246 As Amended or any other Federal Law.

All bidders shall complete the attached certification in duplicate and submit both copies to the Owner with the bid proposal. The Owner (grantee) shall transmit one copy to the Lexington-Fayette Urban County Government, Division of Community Development, within fourteen (14) days after bid opening.

The undersigned hereby certifies that the firm of Davis H. Elliot Construction Company, Inc. has not and will not award a subcontract, in connection with any contract award to it as the result of this bid, to any firm that has been debarred for noncompliance with the Federal labor Standards, Title VI of the civil Rights Act of 1964, Executive Order 11246 as amended or any Federal Law.

Davis H. Elliot Construction Company, Inc.
Name of Firm Submitting Bid

Signature of Authorized Official Julia E. Bellendir

Vice President
Title

4/7/2026
Date

15. DEBARMENT CERTIFICATION

All contractors/subcontractors shall complete the following certification and submit it with the bid proposal.

The contractor/subcontractor certifies in accordance with Executive Order 12549 (Debarment and Suspension 2/18/86) that to the best of its knowledge and belief, that it and its principals:

- 1) Are not presently debarred, suspended, proposed for debarment, declared negligible, or voluntarily excluded from covered transactions or contract by any Federal department or agency for noncompliance with the Federal Labor Standards, Title VI of the Civil Rights Act of 1964 as amended, Executive Order 11246 as amended or any other Federal law;
 - a) Have not within a three year period preceding this proposal been convicted of or had a civil judgment rendered against them for commission of fraud or a criminal offense in connection with obtaining, attempting to obtain, or performing a public (Federal, State or local) transaction or contract under a public transaction; violation of Federal or State antitrust statutes or commission of embezzlement, theft, forgery, bribery, falsification or destruction of records, making false statements, or receiving stolen property;
 - b) Are not presently indicted for or otherwise criminally or civilly charged by a government entity (Federal, State or local) with commission of any of the offenses enumerated in paragraph (1)(a) of this certification; and
 - c) Have not within a three year period preceding this bid has one or more public (Federal, State or local) transactions or contracts terminated for cause or default.

2) Where the contractor is unable to certify to any of the statements in this certification, such prospective contractors shall attach an explanation to this certification form.

Firm Name: Davis H. Elliot Construction Company, Inc.

Project: Concrete Tee Pads and Sign Posts for Disc Golf Course
Bid No. 33-2026

Printed Name and Title of Authorized Representative: Julia E. Bellendir, Vice President

Signature: 

Date: 4/7/2026

END OF SECTION



Davis H. Elliot Construction Company, Inc.

Central Region
673 Blue Sky Parkway
Lexington, Kentucky 40509
Phone: 859-263-5148
Fax: 859-255-5988

Work Experience

Julia Bellendir
Vice President
Central Region

Experience:

2020 – Present Davis H. Elliot Construction Company, Inc.
Lexington, KY

Vice President:

The Vice President is responsible for managing a team of leaders coordinating aspects of operations, safety, estimation and customer services for multiple business units within the Central Region. These business units include, but are not limited to, substation construction and maintenance, highway lighting construction, street light signalization, power locating, and traffic control operations.

Education:

- Master of Industrial-Organizational Psychology, MS
Eastern Kentucky University– 2020
- Bachelor of Psychology
Eastern Kentucky University– 2018

Professional:

- First Aid / CPR
- Safety Trained Supervisor
- 15 Years of management experience



Davis H. Elliot Construction Company, Inc.

Central Region
673 Blue Sky Parkway
Lexington, Kentucky 40509
Phone: 859-263-5148
Fax: 859-255-5988

Experience Profile

Mark D. Corman Jr., CUSP, STSC

Division Manager, Transmission Lines-Substation

Experience:

2010 – Present Davis H. Elliot Construction Company, Inc.
Lexington, KY

Position:

A Division Manager is responsible for all aspects of the Company's service operations including safety, productivity and profitability for traffic and substation lines of business. The Division Manager understands, supports, and enforces the safety and employment policies of the Company. To promote to positions of leadership qualified individuals who have not only the necessary professional skills, but also the personal integrity to represent Elliot. Division Manager establishes and coordinates the efforts of direct reports to safely and efficiently complete all projects.

Education:

- Certificate in Business Administration – University of Kentucky, Gatton College of Business
- BCSP – Safety Trained Supervisor Construction
- Certified Utility Safety Professional

Recent Projects:

- Greenfield Matanzas Substation with LG&E-KU
- Cane Run 7 Switching Substation with LG&E – KU
- Paddy's West Substation Breaker Replacement with LG&E – KU •
Rockvale Substation with Middle Tennessee EMC



682 DURHAM RD, ADAMS, 37010 • DFANAKOS@DHEC.COM • 859-221-3959

DARON FANAKOS

Substation Construction Manager

PROFESSIONAL SUMMARY

Substation Construction Manager with over 17 years of extensive expertise in leading complex electrical projects and optimizing workflows. Demonstrates exceptional skills in team leadership, safety compliance, and project management, consistently delivering high-quality installations while fostering strong client and team relationships. Committed to implementing cutting-edge solutions and driving efficiency to achieve substantial cost savings and meet client needs effectively.

EMPLOYMENT HISTORY

SUPERINTENDENT / GENERAL FOREMAN

Davis H. Elliot

Jan 2008 - Present

Lexington, KY

- ◆ Lead and coordinate complex electrical projects, ensuring timely completion and adherence to safety standards. Oversee team performance and resource allocation.
- ◆ Implement cutting-edge electrical systems, driving efficiency and cost-effectiveness. Develop creative solutions to overcome project challenges and meet client needs.
- ◆ Deliver high-quality electrical installations, consistently meeting project milestones. Optimise workflows to enhance productivity and achieve substantial cost savings.
- ◆ Foster strong relationships with clients, subcontractors, and team members. Facilitate effective communication to ensure smooth project execution and client satisfaction.
- ◆ Meticulously oversee project specifications, ensuring compliance with industry regulations. Conduct thorough quality checks to maintain exceptional standards.

SKILLS

Team Leadership, Safety Compliance, Project Management.

EDUCATION

ASSOCIATES

Liberty University

I received a degree in biblical Studies

Jan 1999 - Jun 2021

Lynchburg, VA

REFERENCES

Paul Tompkins, Power Resources (*petompkins@powerresourcesinc.com, 601-529-2849*);

Andrew Lindsey, Warren Rural Electric (*270-991-0103*); **Sam Shouse**, M.D Henry (*slshouse@mdhenryco.com, 205-482-1065*);

Randy McGuffey Jr., Davis H. Elliot (*wmcguffey@dhec.com, 859-516-3367*);

Larry Taylor, Power Protection Engineering (*larrytaylor@powerprotection-llc.com, 615-533-5551*).

HOBBIES

I love to fly airplanes and ride motorcycles. Most of all I enjoy spending family time with my 6 kids and 5 grandchildren



Davis H. Elliot Construction Company, Inc.

Central Region
673 Blue Sky Parkway
Lexington, Kentucky 40509
Phone: 859-263-5148
Fax: 859-255-5988

Experience Profile

Jon Sowder

General Foreman
Substation Division - Central Region

Experience:

2023 – Present Substation General Foreman

2019 – 2023 Substation Foreman

2016 – 2019 Substation Journeyman

Davis H. Elliot Construction Co, Inc.
Lexington, Ky

Position:

General Foreman: Plan, Schedule, Assign, and Supervise work of Foreman and Journey-Level workers; Involving Substation Construction, Maintenance, Alteration, and Repair. Review in-progress work for adherence to job specifications, safety, efficiency, and project timelines.

Education:

- Lincoln County High School-Diploma
- Garrard County Vocational School-Diploma
- BCTCS

Professional Training:

- NCCCO Crane Certification
- CDL-A
- OSHA 10
- OSHA 10 ETD
- CPR/First Aid

Recent Projects:

- Blue Lick Substation Alteration (LGE/KU)
- South Lancaster Switching Station (EKPC)
- Newfoundland Substation (EKPC)



Davis H. Elliot Construction Company, Inc.

673 Blue Sky Parkway

Lexington, KY 40509

Phone: 859-263-5148

Fax: 859-263-5486

www.dhec.com

Davis H. Elliot Construction Company, Inc.

Subcontractor and Supplier Diversity and Inclusion Policy

Mission Statement

The Davis H. Elliot Company, Inc. (Elliot) strives to create an environment that promotes meaningful business opportunities, showcase viable M/W/DBE firm capabilities, build productive partnerships and exercise effective program management, targeted towards successful integration of M/W/DBE firms within the business structure of the Markets where we work.

The vast majority of Elliot's work is self-performed. Our diversity plan includes looking at every "non-labor" component of our cost structure to employ the use of diverse suppliers which will add value without unnecessary cost burden that would increase our cost of service to the Customer. Attached is a current listing of 2nd Tier Diverse Suppliers which Elliot utilizes. Elliot actively seeks opportunities to support disadvantaged and diverse subcontractors. We advertise, recruit, and otherwise encourage participation when project scope and constraints make subcontracting possible. Elliot maintains a list of suppliers, labor and equipment subcontractors, and specialized service providers in order to maximize our diversity participation.

Disabled, Minority and Women Business Enterprises

The Davis H. Elliot Company strives to maintain an environment that values a diverse supplier base. We believe that by taking the initiative in seeking qualified suppliers, creating, and increasing alliances with and purchasing from M/W/DBEs, and including our customers and consumers in our purchasing strategy, will help build thriving local communities and generate long-term growth, as well as a competitive advantage for us. We do this by offering the greatest possible opportunities for minority and women-owned businesses to contribute as suppliers, contractors, and sub-contractors in our business.



Davis H. Elliot Construction Company, Inc.

673 Blue Sky Parkway
Lexington, KY 40509
Phone: 859-263-5148
Fax: 859-263-5486
www.dhec.com

Diverse Suppliers:

The vast majority of Elliot's work is self-performed. Our diversity plan includes looking at every "non-labor" component of our cost structure to employ the use of diverse suppliers which will add value without unnecessary cost burden that would increase our cost of service to the Customer. Attached is a current listing of 2nd Tier Diverse Suppliers which Elliot utilizes.

Elliot actively seeks opportunities to support disadvantaged and diverse subcontractors. We advertise, recruit, and otherwise encourage participation when project scope and constraints make subcontracting possible. Elliot maintains a list of suppliers, labor and equipment subcontractors, and specialized service providers in order to maximize our diversity participation.



Davis H. Elliot Construction Company, Inc.

673 Blue Sky Parkway
 Lexington, KY 40509
 Phone: 859-263-5148
 Fax: 859-263-5486
 www.dhec.com

2nd Tier Diverse Suppliers

Type of Work	Name of Subcontractor	Classification
Materials	ALH Construction	WBE
Auto Supplies	Baltimore Auto Supply	WBE
Materials	Bluegrass Contracting	VET
Catering	Blume's Catering	MBE
Materials	Captain Construction and Concrete	MBE
Auto Supplies	CBY Enterprises, Inc. (Tire & Tyre Co., LLC.)	MBE
Electrical services	Delta Utility Services, Inc.	WBE
Labor and equipment rental	Eco-Battery	MBE
Materials	Fox Engineering	MBE
Equipment rental	GDM	MBE
Safety consulting	Glenn Smith	WBE
Electrical supply	Gould Electric	MBE
Waste management	Hall Enterprises (dba Logistics Planning Services)	WBE
Traffic Control	Highway Safety Inc.	WBE
Office furniture	Hurst Office Suppliers	WBE
Lodging	Innovative Solutions	WBE
Landscaping	Kimberly Inc.	WBE
Rubber gloves & sleeves	Kinmar	WBE
Equipment rental	Lorenzo Construction Co, LLC	MBE
Materials	Lyndco Inc.	WBE
Security services	Mid-Atlantic Security Agency	MBE
Janitorial services	My Cleaning Service	MBE
Electrical supply	Old Dominion Electric Supply	MBE
Pavement marking	Payne's Parking Designs	MBE
Heating oil	Phoenix Petroleum	MBE
Electrical supply	Precision Contracting	WBE
Office supplies	Rudolph's Office & Computer	WBE
Traffic Control	Safety Caution Equipment	MBE
Materials	ShePaul Enterprises	MBE
Traffic Control	Superior Pavement Markings, Inc.	MBE
Traffic signs	TKM, Inc.	WBE
Equipment rental	TNE Global	MBE
Materials	Toni Levy & Associates (DBA Levy's Construction Building)	MBE
Electrical services	Tucker Construction Group Inc.	MBE
Electrical supply	United American Supply LLC	MBE
Delivery Svcs./Hauling/Fuel/ Equipment rental/Lodging	Xpress Management Solutions	MBE
Delivery Svcs.	Xpress Solutions	MBE



January 8th, 2026

RE: Davis H. Elliot Construction Company, Inc.

To Whom It May Concern,

The Hartford, through its operating entities, has issued surety bonds to Davis H. Elliot Construction Company, Inc. since 2005, during which time we have favorably considered projects up to \$100,000,000 Single/\$300,000,000 Aggregate. Our experience with Davis H. Elliot Construction Company, Inc. has been excellent, and we highly recommend them to you.

As surety for Davis H. Elliot Construction Company, Inc., The Hartford will favorably consider providing a 100% Performance Bond and a 100% Payment Bond for the above captioned project, provided a mutually acceptable contract is awarded to, and executed by Davis H. Elliot Construction Company, Inc.

Please understand that any arrangement for any bonds is a matter between Davis H. Elliot Construction Company, Inc. and Hartford Fire Insurance Company and we assume no liability to third parties or you if, for any reason, we do not issue requested bonds.

The Hartford expressly reserves the right to review the terms and conditions of the contract, contract amount and bond form, evaluate pertinent underwriting data, and verify the adequacy of project financing prior to the issuance of bonds for the referenced project.

The Hartford maintains a company rating of A+ from A.M. Best and Standard and Poor's.

This letter will expire one hundred and eighty (180) days from the above date.

Very Truly Yours,

Zac Eaton
Senior Bond Underwriter
The Hartford



Request for Financial Information

Regarding the request for financial information, the Davis H. Elliot Company, Inc., and its subsidiaries (including Elliot Engineering, Inc., 46Solutions, Inc., Studio46, Inc., UDP, Inc., and Davis H. Elliot Construction Company, Inc.) is a privately held Company. Due to proprietary information, we do not submit financial information. However, if requested by the Owner, within 24-hours of bid opening, we will allow a representative of the Owner to review the requested information at our office located at 673 Blue Sky Parkway, Lexington, KY 40509.



January 2, 2026

Evidence of Authority to Sign – Davis H. Elliot Construction Company, Inc.

This letter serves to certify that the individuals listed below are officers of Davis H. Elliot Construction Company, Inc. and that they have the authority to execute and enter into bids, contracts, bonds, affidavits, and any ancillary documents on behalf of the Company.

David S. Haskins, Chief Executive Officer
Brian T. Briley, President
Brian L. Sarrett, Senior Vice President
Reather Keith Simpson, Senior Vice President
Tyler S. Haskins, Senior Vice President
Scott A. Navis, Vice President - Chief Financial Officer, Secretary and Treasurer
Kenneth D. Keener Jr., Vice President - Operations Services
Robert M. Scott, Vice President – Financial Services
Donald R. Adkins, Vice President – Safety and Training
Robert W. Fronk, Jr., Vice President - Information Technology
John C. Haskins, Vice President – Region Director
Jacob W. Green, Vice President
Jeffrey R. Zellen, Vice President
Julia E. Bellendir, Vice President
James R. Kemper, Vice President

Sincerely,

A handwritten signature in black ink, appearing to read 'Scott A. Navis', is written over a horizontal line.

Scott A. Navis

Vice President - Chief Financial Officer, Secretary and Treasurer

PART IV
GENERAL CONDITIONS
TABLE OF CONTENTS

Article Number	Title	Page
1.	DEFINITIONS	GC-6
2.	PRELIMINARY MATTERS.....	GC-10
3.	CONTRACT DOCUMENTS: INTENT, CONFLICTS, AMENDING AND REUSE	GC-11
4.	AVAILABILITY OF LANDS; PHYSICAL CONDITIONS; REFERENCE POINTS.....	GC-13
5.	CONTRACTOR'S RESPONSIBILITIES	GC-16
6.	OTHER WORK	GC-27
7.	OWNER'S RESPONSIBILITIES.....	GC-28
8.	CONSULTANT'S STATUS DURING CONSTRUCTION	GC-28
9.	CHANGES IN THE WORK	GC-31
10.	CHANGE OF CONTRACT PRICE.....	GC-32
11.	CHANGE OF CONTRACT TIME	GC-39
12.	WARRANTY AND GUARANTEE; TESTS AND INSPECTIONS; CORRECTION, REMOVAL OR ACCEPTANCE OF DEFECTIVE WORK	GC-39
13.	PAYMENTS TO CONTRACTOR AND COMPLETION	GC-43
14.	SUSPENSION OF WORK AND TERMINATION.....	GC-47
15.	MISCELLANEOUS	GC-50

DETAILED TABLE OF CONTENTS OF GENERAL CONDITIONS

1. Definitions
2. Preliminary Matters
 - 2.1 Delivery of Bonds
 - 2.2 Copies of Documents
 - 2.3 Commencement of Contract Time; Notice to Proceed
 - 2.4 Starting the Project
 - 2.5 Before Starting Construction
 - 2.6 Submittal of Schedules
 - 2.7 Preconstruction Conference
 - 2.8 Finalizing Schedules
3. Contract Documents, Intent, Conflicts, Amending, and Reuse
 - 3.1 General
 - 3.2 Intent
 - 3.3 Conflicts
 - 3.4 Amending and Supplementing Contract Documents
 - 3.5 Reuse of Documents
4. Availability of Lands, Physical Conditions, Reference Points
 - 4.1 Availability of Lands
 - 4.2 Physical Conditions
 - 4.3 Physical Conditions - Underground Facilities
 - 4.4 Reference Points
5. CONTRACTOR'S Responsibilities
 - 5.1 Supervision
 - 5.2 Superintendence
 - 5.3 Labor
 - 5.4 Start-Up and Completion of Work
 - 5.5 Materials and Equipment
 - 5.6 Adjusting Progress Schedule
 - 5.7 Substitutes or "Or-Equal" Items
 - 5.8 Subcontractors, Suppliers and Others
 - 5.9 Patent Fees and Royalties
 - 5.10 Permits
 - 5.11 Laws and Regulations
 - 5.12 Taxes
 - 5.13 Use of Premises

- 5.14 Record Drawings
- 5.15 Shop Drawings and Samples
- 5.16 Continuing the Work
- 5.17 Erosion and Sediment Control

- 6. Other Work
 - 6.1 Related Work at Site
 - 6.2 Other Contractors or Utility Owners
 - 6.3 Delays Caused By Others
 - 6.4 Coordination

- 7. OWNER'S Responsibilities
 - 7.1 Communications
 - 7.2 Data and Payments
 - 7.3 Lands, Easements, and Surveys
 - 7.4 Change Orders
 - 7.5 Inspections, Tests, and Approvals
 - 7.6 Stop or Suspend Work

- 8. CONSULTANT'S Status During Construction
 - 8.1 OWNER'S Representative
 - 8.2 Visits to Site
 - 8.3 Project Representation
 - 8.4 Clarification and Interpretations
 - 8.5 Authorized Variations in Work
 - 8.6 Rejecting Defective Work
 - 8.7 Shop Drawings
 - 8.8 Change Orders
 - 8.9 Payments
 - 8.10 Determinations for Unit Prices
 - 8.11 Decisions on Disputes
 - 8.12 Limitations on CONSULTANT'S Responsibilities

- 9. Changes in the Work
 - 9.1 OWNER May Order Changes
 - 9.2 Claims
 - 9.3 Work Not in Contract Documents
 - 9.4 Change Orders
 - 9.5 Notice of Change

- 10. Change of Contract Price
 - 10.1 Total Compensation
 - 10.2 Claim for Increase or Decrease in Price
 - 10.3 Value of Work
 - 10.4 Cost of the Work
 - 10.5 Not to Be Included in Cost of the Work
 - 10.6 CONTRACTOR'S Fee
 - 10.7 Itemized Cost Breakdown
 - 10.8 Cash Allowance
 - 10.9 Unit Price Work

- 11. Change of Contract Time
 - 11.1 Change Order
 - 11.2 Justification for Time Extension
 - 11.3 Time Limits

- 12. Warranty and Guarantee; Tests and Inspections; Correction, Removal or Acceptance of Defective Work
 - 12.1 Warranty and Guarantee
 - 12.2 Access to Work
 - 12.3 Tests and Inspections
 - 12.4 OWNER May Stop Work
 - 12.5 Correction or Removal of Defective Work
 - 12.6 One Year Correction Period
 - 12.7 Acceptance of Defective work
 - 12.8 Owner May Correct Defective Work

- 13. Payments to CONTRACTOR and Completion
 - 13.1 Schedule of Values
 - 13.2 Application for Progress Payments
 - 13.3 CONTRACTOR'S Warranty of Title
 - 13.4 Review of Application for Progress Payments
 - 13.5 Partial Utilization
 - 13.6 Final Inspection
 - 13.7 Final Application for Payment
 - 13.8 Final Payment and Acceptance
 - 13.9 CONTRACTOR'S Continuing Obligation
 - 13.10 Waiver of Claims

14. Suspension of Work and Termination

- 14.1 OWNER May Suspend Work
- 14.2 OWNER May Terminate
- 14.3 CONTRACTOR'S Services Terminated
- 14.4 Payment After Termination
- 14.5 CONTRACTOR May Stop or Terminate

15. Miscellaneous

- 15.1 Claims for Injury or Damage
- 15.2 Non-Discrimination in Employment
- 15.3 Temporary Street Closing or Blockage
- 15.4 Percentage of Work Performed by Prime CONTRACTOR
- 15.5 Clean-up
- 15.6 General
- 15.7 Debris Disposal

END OF SECTION

PART IV

GENERAL CONDITIONS

1. **DEFINITIONS**

Wherever used in these General Conditions or the other Contract Documents, the following terms have the meanings indicated which are applicable to both the singular and plural thereof.

1.1 Addenda

Written or graphic instruments issued prior to the opening of Bids which clarify, correct, or change the Bid Documents or the Contract Documents.

1.2 Agreement

The written agreement between OWNER and CONTRACTOR covering the Work to be performed; other Contract Documents are attached to the Agreement and made a part thereof as provided therein.

1.3 Application for Payment

The form accepted by CONSULTANT which is to be used by CONTRACTOR in requesting progress or final payments and which is to include such supporting documentation as is required by the Contract Documents.

1.4 Bid

The offer or proposal of the Bidder submitted on the prescribed form setting forth the prices for the Work to be performed.

1.5 Bidder

An individual, partnership, or corporation, who submit a Bid for a prime contract with the OWNER, for the Work described in the proposed Contract Documents.

1.6 Bonds

Bid, performance and payment bonds and other instruments of security.

1.7 Calendar Day

A calendar day of twenty-four hours measured from midnight to the next midnight shall constitute a day.

1.8 Change Order

A document recommended by CONSULTANT, which is signed by CONTRACTOR and OWNER and authorizes an addition, deletion or revision in the Work, or an adjustment in the Contract Price or the Contract Time, issued on or after the Effective Date of the Agreement.

1.9 Contract Documents

The Advertisement for Bidders, Information for Bidders, Agreement, Addenda (which pertain to the Contract Documents), CONTRACTOR'S Bid (including documentation accompanying the Bid and any post-bid documentation submitted prior to the Notice of Award) when attached as an exhibit to the Agreement, the Bonds, these General Conditions, the Special Conditions, the Specifications and the Drawings as the same are more specifically identified in the Agreement, together with all amendments, modifications and supplements.

1.10 Contract Unit Price

The monies payable by OWNER to CONTRACTOR under the Contract Documents as stated in the Agreement. Unit Prices are to be firm for the term of this Contract.

1.11 Contract Time

The number of consecutive calendar days between the date of issuance of the Notice to Proceed and the contract completion date.

1.12 CONTRACTOR

The person, firm or corporation with whom OWNER has entered into the Agreement.

1.13 Defective

An adjective which when modifying the word Work refers to Work that is unsatisfactory, faulty or deficient, or does not conform to the Contract Documents, or does not meet the requirements of any inspection, reference standard, test or approval referred to in the Contract Documents, or has been damaged prior to CONSULTANT'S recommendation of final payment (unless responsibility for the protection thereof has been assumed by OWNER).

1.14 Drawings

The drawings which show the character and scope of the Work to be performed and which have been prepared or approved by CONSULTANT and are referred to in the Contract Documents.

1.15 Effective Date of the Agreement

The date indicated in the Agreement on which it becomes effective.

1.16 CONSULTANT

The Lexington-Fayette Urban County Government or its authorized representative.

1.17 Field Order

A documented order issued by CONSULTANT which orders minor changes in the Work, but which does not involve a change in the Contract Price or the Contract Time.

1.18 Giving Notice

Whenever any provision of the Contract Documents requires the giving of written notice, it will be deemed to have been validly given if delivered in person to the

individual or to a member of the firm or to an officer of the corporation for whom it is intended, or if delivered at or sent by registered or certified mail, postage prepaid, to the last business address known to the giver of the notice.

1.19 Laws and Regulations

Laws, rules, regulations, ordinances, codes and/or orders.

1.20 Notice of Award

The written notice by OWNER to the apparent successful bidder stating that upon compliance by the apparent successful bidder with the conditions enumerated therein, within the time specified, OWNER will sign and deliver the Agreement.

1.21 Notice to Proceed

A written notice given by OWNER to CONTRACTOR fixing the date on which the Contract Time will commence to run and on which CONTRACTOR shall start to perform CONTRACTOR'S obligations under the Contract Documents.

1.22 OWNER

The Lexington-Fayette Urban County Government.

1.23 Partial Utilization

Placing a portion of the Work in service for the purpose for which it is intended (or related purpose) before reaching Completion for all the Work.

1.24 Project

The total construction of which the Work to be provided under the Contract Documents may be the whole, or a part as indicated elsewhere in the Contract Documents.

1.25 Inspector

The authorized representative who is assigned to the site or any part thereof.

1.26 Shop Drawings

All drawings, diagrams, illustrations, schedules and other data which are specifically prepared by or for CONTRACTOR to illustrate some portion of the Work and all illustrations, brochures, standard schedules, performance charts, instructions, diagrams and other information prepared by a Supplier and submitted by CONTRACTOR to illustrate material or equipment for some portion of the Work.

1.27 Specifications

Those portions of the Contract Documents consisting of written technical descriptions of materials, equipment, construction systems, standards and workmanship as applied to the Work and certain administrative details applicable thereto.

1.28 Standard Specifications

The "Standard Specifications for Road and Bridge Construction", Transportation Cabinet, Department of Highways, Commonwealth of Kentucky, current edition. MUTCD shall refer to the "Manual of Uniform Traffic Control Devices.

1.29 Subcontractor

An individual, firm or corporation having a direct contract with CONTRACTOR or with any other Subcontractor for the performance of a part of the Work at the site.

1.30 Special Conditions

The part of the Contract Documents which amends or supplements these General Conditions.

1.31 Supplier

A manufacturer, fabricator, supplier, distributor, materialman or vendor.

1.32 Underground Facilities

All pipelines, conduits, ducts, cables, wires, manholes, vaults, tanks, tunnels or other such facilities or attachments, and any encasements containing such facilities which have been installed underground to furnish any of the following services or materials: electricity, gases, steam, liquid petroleum products, telephone or other communications, cable television, sewage and drainage removal, traffic or other control systems or water.

1.33 Unit Price Work

An amount equal to the sum of the established unit prices for each separately identified item of Unit Price Work times the estimated quantity of each item as indicated in the Agreement.

1.34 Work

The entire completed construction or the various separately identifiable parts thereof required to be furnished under the Contract Documents. Work is the result of performing services, furnishing labor and furnishing and incorporating materials and equipment into the construction, all as required by the Contract Documents.

1.35 Time Period

When any period of time is referred to in the Contract Documents by days, it will be computed to exclude the first and include the last day of such period. If the last day of any such period falls on a Saturday or Sunday or on a day made a legal holiday by the law of the applicable jurisdiction, such day will be omitted from the computation.

2. PRELIMINARY MATTERS

2.1 Delivery of Bonds

When the CONTRACTOR delivers the executed Agreements to OWNER, CONTRACTOR shall also deliver to OWNER, such Bonds, Insurance Certificate, and Power of Attorney as CONTRACTOR may be required to furnish.

2.2 Copies of Documents

Owner shall furnish to CONTRACTOR up to three copies (unless otherwise specified in the Special Conditions) of the Contract Documents as are reasonably necessary for the execution of the Work. Additional copies will be furnished, upon request, at the cost of reproduction.

2.3 Commencement of Contract Time; Notice to Proceed

The Contract Time will commence to run on the day specified in the Notice to Proceed.

2.4 Starting the Project

CONTRACTOR shall start to perform the Work on the date when the Contract Time commences to run, but no Work shall be done at the site prior to the date on which the Contract Time commences to run.

2.5 Before Starting Construction

Before undertaking each part of the Work, CONTRACTOR shall carefully study and compare the Contract Documents and check and verify pertinent figures shown thereon and all applicable field measurements. CONTRACTOR shall promptly report in writing to CONSULTANT any conflict, error or discrepancy which CONTRACTOR may discover and shall obtain a written interpretation or clarification from CONSULTANT before proceeding with any Work affected thereby; however, CONTRACTOR shall not be liable to OWNER or CONSULTANT for failure to report any conflict, error or discrepancy in the Contract Documents, unless CONTRACTOR had actual knowledge thereof or should reasonably have known thereof.

2.6 Submittal of Schedules

Within ten days after the effective date of the Agreement (unless otherwise specified) CONTRACTOR shall submit to CONSULTANT for review:

2.6.1 an estimated progress schedule indicating the starting and completion dates of the various stages of the Work;

2.6.2 a preliminary schedule of Shop Drawing submissions; and

2.6.3 a preliminary schedule of values for all of the Work which will include quantities and prices of items aggregating the Contract Price and will subdivide the Work into costs per labor and materials by specification section

to serve as the basis for progress payments during construction. Such prices will include an appropriate amount of overhead and profit applicable to each item of Work which will be confirmed in writing by CONTRACTOR at the time of submission. Schedule of values shall be submitted on AIA G702/703 forms, or approved equal.

2.7 Preconstruction Conference

Before CONTRACTOR starts the Work at the proposed site, a conference attended by CONTRACTOR, CONSULTANT, EEO-Affirmative Action Officer, and other appropriate parties will be held to discuss the following issues: (1) The scheduling of the Work to be completed; (2) The procedures for handling shop drawings and other submittals; (3) The processing of applications for payment; (4) The establishment of an understanding among the involved parties in regard to the proposed project; (5) The establishment of procedures for effectively implementing the LFUCG's 10% minimum DBE goals; and (6) Requirement for Mechanic's Lien on Partial Applications for Payment.

2.8 Finalizing Schedules

At least ten days before submission of the first Application for Payment a conference attended by CONTRACTOR, CONSULTANT and others as appropriate will be held to finalize the schedules submitted in accordance with paragraph 2.6. The finalized progress schedule will be acceptable to CONSULTANT as providing orderly progression of the Work to completion within the Contract Time, but such acceptance will neither impose on CONSULTANT responsibility for the progress or scheduling of the Work nor relieve CONTRACTOR from full responsibility thereof. The finalized schedule of Shop Drawing submissions will be acceptable to CONSULTANT as providing a workable arrangement for processing the submissions. The finalized schedule of values will be acceptable to CONSULTANT as to form and substance.

3. CONTRACT DOCUMENTS: INTENT, CONFLICTS, AMENDING AND REUSE

3.1 General

The Contract Documents comprise the entire agreement between OWNER and CONTRACTOR concerning the Work. The Contract Documents are complementary; what is called for by one is as binding as if called for by all. The Contract Documents will be construed in accordance with the law of the place of the Project.

3.2 Intent

It is the intent of the Contract Documents to describe a functionally complete Project (or part thereof) to be constructed in accordance with the Contract Documents. Any Work, materials or equipment that may reasonably be inferred from the Contract Documents as being required to produce the intended result will be supplied whether or not specifically called for. When words which have a well-known technical or trade meaning are used to

describe Work, materials or equipment such words shall be interpreted in accordance with that meaning. Reference to standard specifications, manuals or codes of any technical society, organization or association, or to the laws or regulations of any governmental authority, whether such reference be specific or by implication, shall mean the latest standard specification, manual, code or laws or regulations in effect at the time of opening of Bids (or, on the Effective Date of the Agreement if there were no Bids), except as may be otherwise specifically stated. However, no provision of any referenced standard specification, manual or code (whether or not specifically incorporated by reference in the Contract Documents) shall be effective to change the duties and responsibilities of OWNER, CONTRACTOR or CONSULTANT, or any of their consultants, agents or employees from those set forth in the Contract Documents, nor shall it be effective to assign to CONSULTANT, or any of CONSULTANT'S consultants, agents or employees, any duty or authority to supervise or direct the furnishing or performance of the Work or any duty or authority to undertake responsibility contrary to the provisions of paragraph 8.12.3 or 8.12.4. Clarifications and interpretations of the Contract Documents shall be issued by CONSULTANT as provided in paragraph 8.4.

3.3 Conflicts

If, during the performance of the Work, CONTRACTOR finds a conflict, error or discrepancy in the Contract Documents, CONTRACTOR shall so report to CONSULTANT in writing at once and before proceeding with the Work affected thereby shall obtain a written interpretation or clarification from CONSULTANT; however, CONTRACTOR shall not be liable to OWNER or CONSULTANT for failure to report any conflict, error or discrepancy in the Contract Documents unless CONTRACTOR had actual knowledge thereof or should reasonably have known thereof.

In resolving such conflicts, errors and discrepancies, the documents shall be given precedence in the following order:

1. Agreement
2. Field and Change Orders
3. Addenda
4. Special Conditions
5. Instruction to Bidders
6. General Conditions
7. Specifications and Drawings

Figure dimension on drawings shall govern over scale dimensions and detailed Drawings shall govern over general Drawings.

3.4 Amending and Supplementing Contract Documents

The Contract Documents may be amended to provide for additions, deletions and revisions in the Work or to modify the terms and conditions thereof by means of a Change Order or a Field Order. Contract Price and Contract Time may only be changed by a Change Order.

3.5 Reuse of Documents

Neither CONTRACTOR nor any Subcontractor or Supplier or other person or organization performing or furnishing any of the Work under a direct or indirect contract with OWNER shall have or acquire any title to or ownership rights in any of the Drawings, Specifications or other documents (or copies of any thereof) prepared by or bearing the seal of CONSULTANT; and they shall not reuse any of them on extensions of the Project or any other project without written consent of OWNER and CONSULTANT and specific written verification or adaptation by CONSULTANT.

4. AVAILABILITY OF LANDS; PHYSICAL CONDITIONS, REFERENCE POINTS

4.1 Availability of Lands

OWNER shall furnish, as indicated in the Contract Documents, the lands upon which the Work is to be performed, rights-of-way and easements for access thereto, and such other lands which are designated for the use of CONTRACTOR. Easements for permanent structures or permanent changes in existing facilities will be obtained and paid for by OWNER, unless otherwise provided in the Contract Documents. If CONTRACTOR believes that any delay in OWNER'S furnishing these lands, rights-of-way or easements entitles CONTRACTOR to an extension of the Contract Time, CONTRACTOR may make a claim therefor as provided in Article 11. CONSULTANT shall determine if the claim is legitimate or not. CONTRACTOR shall provide for all additional lands and access thereto that may be required for temporary construction facilities or storage of materials and equipment.

4.2 Physical Conditions

4.2.1 Explorations and Reports

Reference is made to the Special Conditions for identification of those reports of explorations and tests of subsurface conditions at the site that have been utilized by CONSULTANT in preparation of the Contract Documents. CONTRACTOR may rely upon the accuracy of the technical data contained in such reports, but not upon non-technical data, interpretations or opinions contained therein or for the completeness thereof for CONTRACTOR'S purposes. Except as indicated in the immediately preceding sentence and in paragraph 4.2.6, CONTRACTOR shall have full responsibility with respect to subsurface conditions at the site.

4.2.2 Existing Structures

Reference is made to the Special Conditions for identification of those drawings of physical conditions in or relating to existing surface and subsurface structures (except Underground Facilities referred to in paragraph

4.3 which are at or contiguous to the site that have been utilized by CONSULTANT in preparation of the Contract Documents. CONTRACTOR may rely upon the accuracy of the technical data contained in such drawings, but not for the completeness thereof for CONTRACTOR'S purposes. Except as indicated in the immediately preceding sentence and in paragraph 4.2.6, CONTRACTOR shall have full responsibility with respect to physical conditions in or relating to such structures.

4.2.3 Report of Differing Conditions

If CONTRACTOR believes that:

4.2.3.1 any technical data on which CONTRACTOR is entitled to rely as provided in paragraphs 4.2.1 and 4.2.2 is inaccurate, or

4.2.3.2 any physical conditions uncovered or revealed at the site differ materially from that indicated, reflected or referred to in the Contract Documents,

CONTRACTOR shall, promptly after becoming aware thereof and before performing and WORK in connection therewith (except in an emergency) notify OWNER and CONSULTANT in writing about the inaccuracy or difference.

4.2.4 CONSULTANT'S Review

CONSULTANT will promptly review the pertinent conditions, determine the necessity of obtaining additional explorations or tests with respect thereto and advise CONTRACTOR of CONSULTANT'S findings and conclusions.

4.2.5 Possible Document Change

If CONSULTANT concludes that there is a material error in the Contract Documents or that because of newly discovered conditions a change I the Contract Documents is required, a Change Order will be issued as provided in Article 10 to reflect and document the consequences of the inaccuracy or difference.

4.2.6 Possible Price and Time Adjustments

In each such case, an increase or decrease in the Contract Price or an extension or shortening of the Contract Time, or any combination thereof, will be allowable to the extent that they are attributable to any such inaccuracy or difference.

4.3 Physical Conditions-Underground Facilities

4.3.1 Shown or Indicated

The information and data shown or indicated in the Contract Documents with respect to existing Underground Facilities at or contiguous to the site is based on information and data furnished to OWNER or CONSULTANT by the

owners of such underground facilities or by others. Unless it is otherwise expressly provided in the Special Conditions:

4.3.1.1 OWNER and CONSULTANT shall not be responsible for the accuracy or completeness of any such information or data; and,

4.2.1.2 CONTRACTOR shall have full responsibility for reviewing and checking all such information and data; for locating all underground facilities shown or indicated in the Contract Documents; for coordination of the Work with the owners of such underground facilities during construction; and for the safety and protection thereof and repairing any damage thereto resulting from the Work, the cost of all of which will be considered as having been included in the Contract Price.

4.3.2 Not Shown or Indicated

If an underground facility is uncovered or revealed at or contiguous to the site which was not shown or indicated in the Contract Documents and which CONTRACTOR could not reasonably have been expected to be aware of, CONTRACTOR shall, promptly after becoming aware thereof and before performing any Work affected thereby (except in an emergency), identify the owner of such Underground Facility and give written notice thereof to that owner and to OWNER and CONSULTANT. CONSULTANT will promptly review the underground facility to determine the extent to which the Contract Documents should be modified to reflect and document the consequences of the existence of the Underground Facility, and the Contract Documents will be amended or supplemented to the extent necessary. During such time, CONTRACTOR shall be responsible for the safety and protection of such underground facility. CONTRACTOR shall be allowed an increase in the Contract Price or an extension of the Contract Time, or both, to the extent that they are attributable to the existence of any underground facility that was not shown or indicated in the Contract Documents and which CONTRACTOR could not reasonably have been expected to be aware of.

4.4 Reference Points

OWNER shall provide engineering surveys to establish reference points for construction which in CONSULTANT'S judgment are necessary to enable CONTRACTOR to proceed with the Work. CONTRACTOR shall be responsible for laying out the Work (unless otherwise specified), shall protect and preserve the established reference points and shall make no changes or relocations without the prior written approval of OWNER. CONTRACTOR shall report to CONSULTANT whenever any reference point is lost or destroyed or requires relocation because of necessary changes in grades or locations, and shall be responsible for the accurate replacement or relocation of such reference points by a Registered Land Surveyor.

5. CONTRACTOR'S RESPONSIBILITIES

5.1 Supervision

CONTRACTOR shall supervise and direct the Work competently and efficiently, devoting such attention thereto and applying such skills and expertise as may be necessary to perform the Work in accordance with the Contract Documents. CONTRACTOR shall assure that all CONTRACTOR personnel (including subcontractors, etc.) conduct themselves in a courteous and respectful manner toward the CONSULTANT and the general public. CONTRACTOR shall keep at the Project Site during the progress of the Work a competent project manager/superintendent and all necessary assistants, all of whom shall be satisfactory to OWNER. OWNER reserves the right to reject CONTRACTOR'S construction superintendent and project management personnel if they are unsatisfactory to OWNER and upon such rejection CONTRACTOR shall designate and provide competent successors. Failure to comply with this condition of the Contract will result in immediate suspension of the Work. Following a review by the Commissioner of Public Works, the Contract may be terminated (see GC section 14). CONTRACTOR shall be solely responsible for the means, methods, techniques, sequences and procedures of construction, but CONTRACTOR shall not be responsible for the negligence of others in the design or selection of a specific means, method, technique, sequence or procedure of construction which is indicated in and required by the Contract Documents. CONTRACTOR shall be responsible to see that the finished Work complies accurately with the Contract Documents.

5.2 Superintendence

CONTRACTOR shall keep on the Work at all times during its progress a competent resident superintendent, who shall not be replaced without written notice to OWNER and CONSULTANT except under extraordinary circumstances. The superintendent will be CONTRACTOR'S representative at the site and shall have authority to act on behalf of CONTRACTOR. All communications given to the superintendent shall be as binding as if given to CONTRACTOR.

5.3 Labor

CONTRACTOR shall provide competent, suitably qualified personnel to survey and lay out the Work and perform construction as required by the Contract Documents. CONTRACTOR shall at all times maintain good discipline and order at the site. OWNER reserves the right to require CONTRACTOR to remove from the Project any of its personnel, or subcontractor's personnel for violating LFUCG Policies, Rules or Regulations. Except in connection with the safety or protection of persons or the Work or property at the site or adjacent thereto, and except as otherwise indicated in the Contract Documents, all Work at the site shall be performed during regular working hours, and CONTRACTOR will not permit overtime work or the performance of Work on Saturday, Sunday or any legal holiday without OWNER'S written consent given after prior written notice to CONSULTANT.

5.4 Start-Up and Completion of Work

Unless otherwise specified, CONTRACTOR shall furnish and assume full responsibility for all materials, equipment, labor, transportation, construction

equipment and machinery, tools, appliances, fuel, power, light, heat, telephone, water, sanitary facilities, temporary facilities and all other facilities and incidentals necessary for the furnishing, performance, testing, start-up and completion of the Work.

5.5 Materials and Equipment

All materials and equipment shall be of good quality and new, except as otherwise provided in the Contract Documents. If required by CONSULTANT, CONTRACTOR shall furnish satisfactory evidence (including reports of required tests) as to the kind and quality of materials and equipment. All materials and equipment shall be applied, installed, connected, erected, used, cleaned and conditioned in accordance with the instructions of the applicable supplier except as otherwise provided in the Contract Documents; but no provision of any such instructions will be effective to assign to CONSULTANT, or any of CONSULTANT'S consultants, agents or employees, any duty or authority to supervise or direct the furnishing or performance of the Work or any duty or authority to undertake responsibility contrary to the provisions of paragraph 8.12.3 or 8.12.4.

5.5.1 Not Clearly Specified or Indicated

In all instances where materials specified are obtainable in different sizes, weights, trade grades, qualities or finishes, etc., whose weights, trade grades, qualities or finishes, etc., are not clearly specified or indicated on the Drawings, the CONTRACTOR shall notify the CONSULTANT of all such instances at least five (5) days in advance of receiving the proposals. The CONSULTANT will then determine which size, weight, trade grade, quality, finish, etc., is required.

5.5.2 Coordination of Work

The CONTRACTOR shall see that for his own Work and for the work of each subcontractor, proper templates and patterns necessary for the coordination of the various parts of the Work are prepared. The CONTRACTOR shall furnish or require the Subcontractor to furnish such duplicates as will enable the Subcontractors to fit together and execute fully their respective portions of the Work.

5.6 Adjusting Progress Schedule

CONTRACTOR shall submit to CONSULTANT for acceptance (to the extent indicated in paragraph 2.8) adjustments in the progress schedule to reflect the impact thereon of new developments; these will conform generally to the progress schedule then in effect and additionally will comply with any provisions of the Contract Documents applicable thereto.

5.7 Substitutes or “Or-Equal” Items

5.7.1 General

Whenever materials or equipment are specified or described in the Contract Documents by using the name of a proprietary item or the name of a particular

supplier, the naming of the item is intended to establish the type, function, and quality required. Unless the name is followed by words indicating that no substitution is permitted, materials or equipment of other Suppliers may be accepted by OWNER/CONSULTANT if sufficient information is submitted by CONTRACTOR to allow OWNER/CONSULTANT to determine that the material or equipment proposed is equivalent or equal to that named. The procedure for review by OWNER/CONSULTANT will include the following. Requests for review of substitute items of material and equipment will not be accepted by OWNER/CONSULTANT from anyone, other than CONTRACTOR. If CONTRACTOR wishes to furnish or use a substitute item of material or equipment, CONTRACTOR shall make written application to OWNER/CONSULTANT for acceptance thereof, certifying that the proposed substitute will perform adequately the functions and achieve the results called for by the general design, be similar and of equal substance to that specified and be suited to the same use as that specified. The application will state that the evaluation and acceptance of the proposed substitute will not prejudice CONTRACTOR'S achievement of completion on time, whether or not acceptance of the substitute for use in the Work will require a change in any of the Contract Documents (or in the provisions of any other direct contract with OWNER for work on the Project) to adapt the design to the proposed substitute and whether or not incorporation or use of the substitute in connection with the Work is subject to payment of any license fee or royalty. All variations of the proposed substitute from that specified will be identified in the application and available maintenance, repair and replacement service will be indicated. The application will also contain an itemized estimate of all costs that will result directly or indirectly from acceptance of such substitute, including costs of redesign and claims of other contractors affected by the resulting change, all of which shall be considered by OWNER/CONSULTANT in evaluating the proposed substitute. OWNER/CONSULTANT may require CONTRACTOR to furnish at CONTRACTOR'S expense additional data about the proposed substitute.

5.7.2 Substitutes

If a specific means, method, technique, sequence or procedure of construction is indicated in or required by the Contract Documents, CONTRACTOR may furnish or utilize a substitute means, method, sequence, technique or procedure of construction acceptable to OWNER/CONSULTANT, if CONTRACTOR submits sufficient information to allow OWNER/CONSULTANT to determine that the substitute proposed is equivalent to that indicated or required by the Contract Documents. The procedure for review by OWNER/CONSULTANT will be similar to that provided in paragraph 5.7.1 as applied by OWNER/CONSULTANT.

5.7.3 OWNER/CONSULTANT'S Approval

OWNER/CONSULTANT will be allowed a reasonable time within which to evaluate each proposed substitute. OWNER/CONSULTANT will be the

sole judge of acceptability, and no substitute will be ordered, installed or utilized without OWNER/CONSULTANT'S prior written acceptance which will be evidenced by either a Change Order or an approved Shop Drawing. OWNER may require CONTRACTOR to furnish at CONTRACTOR'S expense a special performance guarantee or other surety with respect to any substitute. OWNER/CONSULTANT will record time required by OWNER/CONSULTANT and OWNER/CONSULTANT'S consultants in evaluating substitutions proposed by CONTRACTOR and in making changes in the Contract Documents occasioned thereby. Whether or not OWNER/CONSULTANT accepts a proposed substitute, CONTRACTOR shall reimburse OWNER for the charges of OWNER/CONSULTANT and OWNER/CONSULTANT'S consultants for evaluating each proposed substitute.

5.8 Subcontractors, Suppliers, and Others

5.8.1 Acceptable to CONSULTANT

CONTRACTOR shall not employ any Subcontractor, Supplier or other person or organization (including those acceptable to OWNER and CONSULTANT as indicated in paragraph 5.8.2), whether initially or as a substitute, against whom OWNER or CONSULTANT may have reasonable objection. CONTRACTOR shall not be required to employ any Subcontractor, Supplier or other person or organization to furnish or perform any of the Work against whom CONTRACTOR has reasonable objection.

5.8.2 Objection After Due Investigation

If the Contract Documents require the identity of certain Subcontractors, Suppliers or other persons or organizations (including those who are to furnish the principal items of materials and equipment) to be submitted to OWNER in advance of the specified date prior to the Effective Date of the Agreement for acceptance by OWNER and CONSULTANT and if CONTRACTOR has submitted a list thereof, OWNER'S or CONSULTANT'S acceptance (either in writing or by failing to make written objection thereto by the date indicated for acceptance or objection in the bidding documents or the Contract Documents) of any such Subcontractor, Supplier or other person or organization so identified may be revoked on the basis of reasonable objection after due investigation, in which case CONTRACTOR shall submit an acceptable substitute. No acceptance by OWNER or CONSULTANT of any such Subcontractor, Supplier or other person or organization shall constitute a waiver of any right of OWNER or CONSULTANT to reject defective Work.

5.8.3 Contractor Responsible for Acts of Subcontractors

The CONTRACTOR shall perform on the site, and with its own organization, work equivalent to at least fifty (50) percent of the total amount of Work to be performed under the Contract. This percentage may be reduced by a

supplemental agreement to this Contract if, during performing the Work, the CONTRACTOR requests a reduction and the Urban County project manager determines that the reduction would be to the advantage of the Urban County Government.

The CONTRACTOR shall, at the time he submits his proposal for the Contract, notify the OWNER in writing of the names of Subcontractors proposed for the Work. He shall not employ any Subcontractor without the prior written approval of the OWNER.

CONTRACTOR shall be fully responsible to OWNER and CONSULTANT for all acts and omissions of the Subcontractors, Suppliers and other persons and organizations performing or furnishing any of the Work under a direct or indirect contract with CONTRACTOR just as CONTRACTOR is responsible for CONTRACTOR'S own acts and omissions. Nothing in the Contract Documents shall create any contractual relationship between OWNER or CONSULTANT and any such Subcontractor, Supplier or other person or organization, nor shall it create any obligation on the part of OWNER or CONSULTANT to pay or to see to the payment of any moneys due any such Subcontractor, Supplier or other person or organization except as may otherwise be required by Laws and Regulations.

5.8.4 Division of Specifications

The divisions and sections of the Specifications and the identifications of any Drawings shall not control CONTRACTOR in dividing the Work among Subcontractors or Suppliers or delineating the Work to be performed by any specific trade.

5.8.5 Agreement Between Contractor and Subcontractors

All Work performed for CONTRACTOR by a Subcontractor will be pursuant to an appropriate agreement between CONTRACTOR and the Subcontractor which specifically binds the Subcontractor to the applicable terms and conditions of the Contract Documents for the benefit of OWNER and CONSULTANT.

5.8.6 Statements and Comments by CONTRACTOR

Neither the CONTRACTOR, his employees, nor his subcontractors shall at any time make any statement or comment as to the project scope, nature, intention, design, or construction method to any third party or parties without the explicit written consent of the OWNER.

Any third party requesting such information shall be referred to the OWNER or his representative.

Should there be any change from the original intent of the project as a result of any statement or comment by the contractor, his employees or

subcontractors, contractor shall be held liable for any change in the scope, nature, design, or construction method and shall bear the full cost for the previously mentioned changes.

5.9 Patent Fees and Royalties

CONTRACTOR shall pay all license fees and royalties and assume all costs incident to the use in the performance of the Work or the incorporation in the Work of any invention, design, process, product or device which is the subject of patent rights or copyrights held by others.

5.10 Permits

Unless otherwise provided in the Special conditions, CONTRACTOR shall obtain and pay for all construction permits and licenses. OWNER shall assist CONTRACTOR, when necessary, in obtaining such permits and licenses. CONTRACTOR shall pay all governmental charges and inspection fees necessary for the prosecution of the Work, which are applicable at the time of opening of Bids, or if there are no Bids on the Effective Date of the Agreement. CONTRACTOR shall pay all charges of utility owners for connections to the Work, and OWNER shall pay all charges of such utility owners for capital costs related thereto such as plant investment fees.

5.11 Laws and Regulations

5.11.1 CONTRACTOR to Comply

CONTRACTOR shall give all notices and comply with all Laws and Regulations applicable to furnishing and performance of the Work. Except where otherwise expressly required by applicable Laws and Regulations, neither OWNER nor CONSULTANT shall be responsible for monitoring CONTRACTOR'S compliance with any Laws and Regulations.

5.11.2 Specifications and Drawings at Variance

If CONTRACTOR observes that the Specifications or Drawings are at variance with any Laws or Regulations, CONTRACTOR shall give CONSULTANT prompt written notice thereof, and any necessary changes will be authorized by one of the methods indicated in paragraph 3.4. If CONTRACTOR performs any Work knowing or having reason to know that it is contrary to such Laws, or Regulations, and without such notice to CONSULTANT, CONTRACTOR shall bear all costs arising therefrom; however, it shall not be CONTRACTOR'S primary responsibility to make certain that the Specifications and Drawings are in accordance with such Laws and Regulations.

Any party, firm or individual submitting a proposal pursuant to invitation must have paid all taxes owed to the Lexington-Fayette Urban County Government

at the time the proposal is submitted, and must maintain a "current" status in regard to those taxes throughout the Contract. If applicable, business must be licensed in Fayette County.

5.12 Taxes

CONTRACTOR shall pay all sales, consumer, use and other similar taxes required to be paid by CONTRACTOR in accordance with the Laws and Regulations of the place of the Project which are applicable during the performance of the Work. Any party, firm or individual submitting a proposal pursuant to invitation must have paid all taxes owed to the Lexington-Fayette Urban County Government at the time the proposal is submitted, and must maintain a "current" status in regard to those taxes throughout the Contract. If applicable, business must be licensed in Fayette County.

5.13 Use of Premises

5.13.1 Project Site

CONTRACTOR shall confine construction equipment, the storage of materials and equipment and the operations of workers to the staging areas or work site areas identified in and permitted by the Contract Documents and other land and areas permitted by Laws and Regulations, rights-of-way, permits and easements, and shall not unreasonably encumber the premises with construction equipment or other materials or equipment. CONTRACTOR shall assume full responsibility for any damage to any such land or area, or to the owner or occupant thereof or of any land or areas contiguous thereto, resulting from the performance of the Work. Should any claim be made against OWNER or CONSULTANT by any such owner or occupant because of the performance of the Work, CONTRACTOR shall promptly attempt to settle with such other party by agreement or otherwise resolve the claim by arbitration or at law. CONTRACTOR shall, to the fullest extent permitted by Laws and Regulations, indemnify and hold OWNER and CONSULTANT harmless from and against all claims, damages, losses and expenses (including, but not limited to, fees of engineers, architects, attorneys and other professionals and court and arbitration costs) arising directly, indirectly or consequentially out of any action, legal or equitable, brought by any such other party against OWNER or CONSULTANT to the extent based on a claim arising out of CONTRACTOR'S performance of the Work.

5.13.2 Clean UP

During the progress of the Work, CONTRACTOR shall keep the premises free from accumulations of waste materials, rubbish and other debris resulting from the Work. At the completion of the Work, CONTRACTOR shall remove all waste materials, rubbish and debris from and about the premises as well as all tools, appliances, construction equipment and machinery, and surplus materials, and shall leave the site clean and ready for occupancy by OWNER. CONTRACTOR shall restore to original condition all property not designated for alteration by the Contract Documents.

5.13.1 Loading of Structures

CONTRACTOR shall not load nor permit any part of any structure to be loaded in any manner that will endanger the structure, nor shall CONTRACTOR subject any part of the Work or adjacent property to stresses or pressures that will endanger it.

5.14 Record Drawings

CONTRACTOR shall maintain in a safe place at the site one record copy of all Drawings, Specifications, Addenda, Change Orders, Field Orders and written interpretations and clarifications (issued pursuant to paragraph 9.4) in good order and annotated to show all changes made during construction. These record documents together with all approved samples and a counterpart of all approved Shop Drawings will be available to CONSULTANT for reference. Upon completion of the Work, these record documents, samples and Shop Drawings will be delivered to CONSULTANT for OWNER.

5.15 Shop Drawings and Samples

5.15.1 Shop Drawing Submittals

After checking and verifying all field measurements and after complying with applicable procedures specified, CONTRACTOR shall submit to CONSULTANT for review and approval in accordance with the accepted schedule of Shop Drawing submissions (see paragraph 2.8), or for other appropriate action if so indicated in the Special Conditions, five copies (unless otherwise specified) of all Shop Drawings, which will bear a stamp or specific written indication that CONTRACTOR has satisfied CONTRACTOR'S responsibilities under the Contract Documents with respect to the review of the submission. All submissions will be identified as CONSULTANT may require. The data shown on the Shop Drawings will be complete with respect to quantities, dimensions, specified performance and design criteria, materials and similar data to enable CONSULTANT to review the information as required.

5.15.2 Sample Submittals

CONTRACTOR shall also submit to CONSULTANT for review and approval with such promptness as to cause no delay in Work, all samples required by the Contract Documents. All samples will have been checked by and accompanied by a specific written indication that CONTRACTOR has satisfied CONTRACTOR'S responsibilities under the Contract Documents with respect to the review of the submission and will be identified clearly as to material, Supplier, pertinent data such as catalog numbers and the use for which intended.

5.15.3 Review by CONTRACTOR

Before submission of each Shop Drawing or sample CONTRACTOR shall have determined and verified all quantities, dimensions, specified performance criteria, installation requirements, materials, catalog numbers and similar data with respect thereto and reviewed or coordinated each Shop Drawing or sample with other Shop Drawings and samples and with the requirements of the Work and the Contract Documents.

5.15.4 Notice of Variation

At the time of each submission, CONTRACTOR shall give CONSULTANT specific written notice of each variation that the Shop Drawings or samples may have from the requirements of the Contract Documents, and, in addition, shall cause a specific notation to be made on each Shop Drawing submitted to CONSULTANT for review and approval of each such variation.

5.15.5 CONSULTANT'S Approval

CONSULTANT will review and approve with reasonable promptness Shop Drawings and samples, but CONSULTANT'S review and approval will be only for conformance with the design concept of the Project and for compliance with the information given in the Contract Documents and shall not extend to means, methods, techniques, sequences or procedures of construction (except where a specific means, method, technique, sequence or procedure of construction is indicated in or required by the Contract Documents) or to safety precautions or programs incident thereto. The review and approval of a separate item as such will not indicate approval of the assembly in which the item functions. CONTRACTOR shall make corrections required by CONSULTANT, and shall return the required number of corrected copies of Shop Drawings and submit, as required, new samples for review and approval. CONTRACTOR shall direct specific attention in writing to revisions other than the corrections called for by CONSULTANT on previous submittals.

5.15.6 Responsibility for Errors and Omissions

CONSULTANT'S review and approval of Shop Drawings or samples shall not relieve CONTRACTOR from responsibility for any variation from the requirements of the Contract Documents unless CONTRACTOR has in writing called CONSULTANT'S attention to each such variation at the time of submission as required by paragraph 5.15.4 and CONSULTANT has given written approval of each such variation by a specific written notation thereof incorporated in or accompanying the Shop Drawing or sample approval; nor will any approval by CONSULTANT relieve CONTRACTOR from responsibility for errors or omissions in the Shop Drawings or from responsibility for having complied with the provisions of paragraph 5.15.3.

5.15.7 Cost of Related Work

Where a Shop or sample is required by the Specifications, any related Work performed prior to CONSULTANT'S review and approval of the pertinent submission will be the sole expense and responsibility of CONTRACTOR.

5.16 Continuing the Work

CONTRACTOR shall carry on the Work and adhere to the progress schedule during all disputes or disagreements with OWNER. No Work shall be delayed or postponed pending resolutions of any disputes or disagreements, except as permitted by paragraph 14.5 or as CONTRACTOR and OWNER may otherwise agree in writing.

5.17 Erosion and Sediment Control

5.17.1 General Environmental Requirements

The CONTRACTOR and Subcontractors performing work on projects on behalf of the OWNER shall comply with all applicable federal, state, and local environmental regulations and all requirements and conditions set forth in "special" permits including but not limited to Corp of Engineers 404 permits, 401 Water Quality Certifications, Stream Crossing and Floodplain Encroachment Permits.

Any fines or penalties resulting from the failure to comply with the terms of the federal, state or local permits or perform necessary corrective action are solely the obligation of the CONTRACTOR.

5.17.2 Stormwater Pollution Prevention

A. The CONTRACTOR shall exercise due care to prevent or minimize any damage to any stream or wetland from pollution by debris, sediment or other material. The operation of equipment and/or materials in a jurisdictional wetland is expressly prohibited. Water that has been used for washing or processing, or that contains oils, sediments or other pollutants shall not be discharged from the job site. Such waters shall be collected and properly disposed of by the CONTRACTOR in accordance with applicable local, state and federal law.

B. The CONTRACTOR is solely responsible for securing all required state and local permits associated with stormwater discharges from the project including, but not necessarily limited to the KY Notice of Intent to Disturb (NOI) for Coverage of Storm Water Discharges Associated with Construction Activities under the KPDES Storm Water General Permit KYR100000 and the LFUCG, Land Disturbance Permit. Permit application preparation and all required documentation are the responsibility of the CONTRACTOR. The CONTRACTOR is solely responsible for maintaining compliance with the stormwater pollution prevention plan or erosion and sediment control plan and ensuring the following:

- a. That the Stormwater Pollution Prevention Plan (SWPPP) or erosion control plan is current and available for review on site;
- b. That any and all stormwater inspection reports required by the permit are conducted by qualified personnel and are available for review onsite; and
- c. That all best management practices (BMPs) are adequately maintained and effective at controlling erosion and preventing sediment from leaving the site.

C. The CONTRACTOR shall provide the necessary equipment and personnel to perform any and all emergency measures that may be required to contain any spillage or leakage and to remove materials, soils or liquids that become contaminated. The collected spill material shall be properly disposed at the CONTRACTOR's expense.

D. Upon completion of the work and with the concurrence of the OWNER, the CONTRACTOR must file a Notice of Termination (NOT) of Coverage Under the KPDES General Permit for Storm Water Discharges Associated with Construction Activity with the appropriate local and state authorities.

E. Any fines or penalties resulting from the failure to comply with the terms of the state or local stormwater permits or perform necessary corrective action are solely the obligation of the CONTRACTOR.

6. OTHER WORK

6.1 Related Work at Site

OWNER may perform other work related to the Project at the site by OWNER'S own forces, have other work performed by utility owners or let other direct contracts therefor which shall contain General Conditions similar to these. If the fact that such other work is to be performed was not noted in the Contract Documents, written notice thereof will be given to CONTRACTOR prior to starting any such other work; and, if such performance will involve additional expense to CONTRACTOR or requires additional time, a Change Order to the Contract will be negotiated.

6.2 Other Contractors or Utility Owners

CONTRACTOR shall afford each utility owner and other contractor who is a party to such a direct contract (or OWNER, if OWNER is performing the additional work with OWNER'S employees) proper and safe access to the site and a reasonable opportunity for the introduction and storage of materials and equipment and the execution of such work, and shall properly connect and coordinate the Work with theirs. CONTRACTOR shall do all cutting, fitting and patching of the Work that may be required to make its several parts come together properly and integrate with such other work. CONTRACTOR shall not endanger any work of others by cutting, excavating or otherwise altering their work and will only cut or alter their work with the written consent of CONSULTANT and the others whose work will be affected. The duties

and responsibilities of CONTRACTOR under this paragraph are for the benefit of such utility owners and other contractors to the extent that there are comparable provisions for the benefit of CONTRACTOR in said direct contracts between OWNER and such utility owners and other contractors.

6.3 Delays Caused by Others

If any part of CONTRACTOR'S Work depends for proper execution or results upon the work of any such other contractor or utility owner (or OWNER), CONTRACTOR shall inspect and promptly report to CONSULTANT in writing any delays, defects or deficiencies in such work that render it unavailable or unsuitable for such proper execution and results. CONTRACTOR'S failure so to report will constitute an acceptance of the other work as fit and proper for integration with CONTRACTOR'S Work except for latent or non-apparent defects and deficiencies in the other work.

6.4 Coordination

If OWNER contracts with others for the performance of other work on the Project at the site, the person or organization who will have authority and responsibility for coordination of the activities among the various prime contractors will be identified in the Special Conditions, and the specific matters to be covered by such authority and responsibility will be itemized, and the extent of such authority and responsibilities will be provided, in the Special Conditions.

7. OWNER'S RESPONSIBILITIES

7.1 Communications

OWNER shall issue all communications to CONTRACTOR through CONSULTANT.

7.2 Data and Payments

OWNER shall furnish the data required of OWNER under the Contract Documents promptly after they are due.

7.3 Lands, Easements, and Surveys

OWNER'S duties in respect of providing lands and easements and providing engineering surveys to establish reference points are set forth in paragraphs 4.1 and 4.4. Paragraph 4.2 refers to OWNER'S identifying and making available to CONTRACTOR copies of reports of explorations and tests of subsurface conditions at the site and in existing structures which have been utilized by CONSULTANT in preparing the Drawings and Specifications.

7.4 Change Orders

OWNER is obligated to execute Change Orders as indicated in paragraph 9.4.

7.5 Inspections, Tests and Approvals

OWNER'S responsibility in respect to certain inspections, tests and approvals is set forth in paragraph 13.3.

7.6 Stop or Suspend Work

In connection with OWNER'S right to stop Work or suspend Work, see paragraph 12.4 and 14.1 Paragraph 14.2 deals with OWNER'S rights to terminate services of CONTRACTOR under certain circumstances.

8. CONSULTANT'S STATUS DURING CONSTRUCTION

8.1 OWNER'S Representative

CONSULTANT will be OWNER'S representative during the construction period. The duties and responsibilities and the limitations of authority of CONSULTANT as OWNER'S representative during construction are set forth in the Contract Documents and shall not be extended without written consent of OWNER and CONSULTANT.

8.2 Visits to Site

CONSULTANT will make visits to the site at intervals appropriate to the various stages of construction to observe the progress and quality of the executed Work and to determine, in general, if the Work is proceeding in accordance with the Contract Documents. CONSULTANT will not be required to make exhaustive or continuous on-site inspections to check the quality or quantity of the Work. CONSULTANT'S efforts will be directed toward providing for OWNER a greater degree of confidence that the completed Work will conform to the Contract Documents. On the basis of such visits and on-site observations, CONSULTANT will keep OWNER informed of the progress of the Work and will endeavor to guard OWNER against defects and deficiencies in the Work.

8.3 Project Representation

CONSULTANT will provide an Inspector to assist CONSULTANT in observing the performance of the Work. If OWNER designates another agent to represent OWNER at the site who is not CONSULTANT'S agent or employee, the duties, responsibilities and limitations of authority of such other person will be as provided in the Special Conditions.

8.4 Clarifications and Interpretations

CONSULTANT will issue with reasonable promptness such written clarifications or interpretations of the requirements of the Contract Documents (in the form of Drawings or otherwise) as CONSULTANT may determine necessary, which shall be consistent with or reasonably inferable from the overall intent of the Contract Documents.

8.5 Authorized Variations in Work

CONSULTANT may authorize minor variations in the Work from the requirements of the Contract Documents which do not involve an adjustment in the Contract Price or the Contract Time and are consistent with the overall intent of the Contract Documents. These may be accomplished by a Field Order.

8.6 Rejecting Defective Work

CONSULTANT will have authority to disapprove or reject Work which CONSULTANT believes to be defective, and will also have authority to require special inspection or testing of the Work as provided in paragraph 12.3, whether or not the Work is fabricated, installed or completed.

8.7 Shop Drawings

In connection with CONSULTANT'S responsibility for Shop Drawings and samples, see paragraphs 5.15.1 through 5.16 inclusive.

8.8 Change Orders

In connection with CONSULTANT'S responsibilities as to Change Orders, see Articles 10, 11 and 12.

8.9 Payments

In connection with CONSULTANT'S responsibilities with respect to Applications for Payment, etc., see Article 13.

8.10 Determinations for Unit Prices

CONSULTANT will determine the actual quantities and classifications of Unit Price Work performed by CONTRACTOR.

CONSULTANT will review with CONTRACTOR CONSULTANT'S preliminary determinations on such matters before rendering a written decision thereon (by recommendation of an Application for Payment or otherwise).

8.11 Decision on Disputes

CONSULTANT will be the initial interpreter of the requirements of the Contract Documents and judge of the acceptability of the Work thereunder. Claims, disputes and other matters relating to the acceptability of the Work or the interpretation of the requirements of the Contract Documents pertaining to the performance and furnishing of the Work and claims under Articles 10 and 11 in respect of changes in the Contract Price or Contract Time will be referred initially to CONSULTANT in writing with a request for a formal decision in accordance with this paragraph, which CONSULTANT will render in writing within a reasonable time. Written notice of each such claim, dispute and other matter will be delivered to CONSULTANT promptly (but in no event later than thirty days) after the occurrence of the event giving rise thereto, and written supporting data will be submitted to CONSULTANT within sixty days after such occurrence unless CONSULTANT allows an additional period of time to ascertain more accurate data in support of the claim.

8.12 Limitations on CONSULTANT'S Responsibilities

8.12.1 CONTRACTOR, Supplier, or Surety

Neither CONSULTANTS authority to act under this Article 8 or elsewhere in the Contract Documents nor any decision made by CONSULTANT in good faith either to exercise or not exercise such authority shall give rise to any duty or responsibility of CONSULTANT to CONTRACTOR, any Subcontractor, any Supplier, or any other person or organization performing any of the Work, or to any surety for any of them.

8.12.2 To Evaluate the Work

Whenever in the Contract Documents the terms "as ordered", "as directed", "as required", "as allowed", "as approved" or terms of like effect or import are used, or the adjectives "reasonable", "suitable", "acceptable", "proper", or "satisfactory" or adjectives or like "effect" or "import" are used to describe a requirement, direction, review or judgment of CONSULTANT as to the Work, it is intended that such requirement, direction, review or judgment will be solely to evaluate the Work for compliance with the Contract Documents (unless there is a specific statement indicating otherwise). The use of any such term or adjective shall not be effective to assign CONSULTANT any duty or authority to supervise or direct the furnishing or performance of the Work or any duty or authority to undertake responsibility contrary to the provisions of paragraph 8.12.3 or 8.12.4.

8.12.3 CONTRACTOR'S Means, Methods, Etc.

CONSULTANT will not be responsible for CONTRACTOR'S means, methods, techniques, sequences or procedures of construction, or the safety precautions and programs incident thereto, and CONSULTANT will not be responsible for CONTRACTOR'S failure to perform or furnish the Work in accordance with the Contract Documents.

8.12.4 Acts of Omissions of CONTRACTOR

CONSULTANT will not be responsible for the acts or omissions of CONTRACTOR or of any Subcontractor, any Supplier, or of any other person or organization performing or furnishing any of the Work.

9. **CHANGES IN THE WORK**

9.1 **OWNER May Order Change**

Without invalidating the Agreement and without notice to any surety, OWNER may, at any time or from time to time, order additions, deletions or revisions in the Work; these will be authorized by a Change Order. Upon receipt of such notice, CONTRACTOR shall promptly proceed with the Work involved which will be performed under the applicable conditions of the Contract Documents (except as otherwise specifically provided).

9.2 **Claims**

Claims for an increase or decrease in the Contract Price or an extension or shortening or the Contract Time that should be allowed as a result of a Change Order will be settled as provided for in Article 10 or Article 11.

9.3 Work Not in Contract Documents

CONTRACTOR shall not be entitled to an increase in the Contract Price or an extension of the Contract Time with respect to any Work performed that is not required by the Contract Documents as amended, modified and supplemented as provided in paragraph 3.4, except in the case of an emergency and except in the case of uncovering Work as provided in paragraph 12.3.4.

9.4 Change Orders

OWNER and CONTRACTOR shall execute appropriate Change Orders covering:

9.4.1 changes in the Work which are ordered by OWNER pursuant to paragraph 9.1, are required because of acceptance of defective Work under paragraph 12.7 or corrective defective Work under paragraph 12.8, or are agreed to by the parties;

9.4.2 changes in the Contract Price or Contract Time which are agreed to by the parties; and

9.4.3 changes in the Contract Price or Contract Time which embody the substance of any written decision rendered by CONSULTANT pursuant to paragraph 8.11; provided that, in lieu of executing any such Change Order, an appeal may be taken from any such decision in accordance with the provisions of the Contract Documents and applicable Laws and REGULATIONS, but during any such appeal, CONTRACTOR shall carry on the Work and adhere to the progress schedule as provided in paragraph 5.16.

9.5 Notice of Change

If notice of any change affecting the general scope of the Work or the provisions of the Contract Documents (including, but not limited to, Contract Price or Contract Time) is required by the provisions of any Bond to be given to a surety, the giving of any such notice will be CONTRACTOR'S responsibility, and the amount of each applicable Bond will be adjusted accordingly.

10. CHANGE OF CONTRACT PRICE

10.1 Total Compensation

The Contract Price constitutes the total compensation (subject to authorized adjustments) payable to CONTRACTOR for performing the Work. All duties, responsibilities and obligations assigned to or undertaken by CONTRACTOR shall be at his expense without change in the Contract Price.

10.2 Claim for Increase or Decrease in Price

The Contract Price may only be changed by a Change Order. Any claim for an increase or decrease in the Contract Price shall be based on written notice delivered by the CONTRACTOR to the CONSULTANT promptly (but in no event later than thirty days) after the occurrence of the event giving rise to the claim and stating the general nature of the claim. Notice of the amount of the claim with supporting data shall be delivered within sixty days after such occurrence (unless CONSULTANT allows an additional period of time to ascertain more accurate data in support of the claim) and shall be accompanied by CONTRACTOR'S written statement that the amount claimed covers all known amounts (direct, indirect, and consequential) to which the CONTRACTOR is entitled as a result of the occurrence of said event.

10.3 Value of Work

The value of any Work covered by a Change Order or of any claim for an increase or decrease in the Contract Price shall be determined in one of the following ways:

10.3.1 Unit Prices

Where the Work involved is covered by unit prices contained in the Contract Documents, by application of unit prices to the quantities of the items involved (subject to the provisions of paragraphs 10.9.1. through 10.9.3, inclusive).

10.3.2 Lump Sum

By mutual acceptance of a lump sum (which may include an allowance for overhead and profit not necessarily in accordance with paragraph 10.6.2.1).

10.3.3 Cost Plus Fee

On the basis of the Cost of the Work (determined as provided in paragraphs 10.4 and 10.5) plus a CONTRACTOR'S fee for overhead and profit (determined as provided in paragraphs 10.6 and 10.7).

10.4 Cost of the Work

The term Cost of the Work means the sum of all costs necessarily incurred and paid by CONTRACTOR in the proper performance of the Work. Except as otherwise may be agreed to in writing by OWNER, such costs shall be in amounts no higher than those prevailing in the locality of the Project; shall include only the following items; and shall not include any of the costs itemized in paragraph 10.5:

10.4.1 Payroll Costs

Payroll costs for employees in the direct employ of CONTRACTOR in the performance of the Work under schedules of job classifications agreed upon by OWNER and CONTRACTOR. Payroll costs for employees not employed full time on the Work shall be apportioned on the basis of their time spent on the Work. Payroll costs shall include, but not be limited to, salaries and wages plus the cost of fringe benefits which shall include social security contributions,

unemployment, excise and payroll taxes, workers' or workmen's compensation, health and retirement benefits, bonuses, sick leave, vacation and holiday pay applicable thereto. Such employees shall include superintendents and foremen at the site. The expenses of performing Work after regular working hours, on Saturday, Sunday or legal holidays, shall be included in the above to the extent authorized by OWNER.

10.4.2 Materials and Equipment Costs

Cost of all materials and equipment furnished and incorporated in the Work, including costs of transportation and storage thereof, and Suppliers' field services required in connection therewith. All cash discounts shall accrue to CONTRACTOR unless OWNER deposits funds with CONTRACTOR with which to make payments, in which case the cash discounts shall accrue to OWNER. All trade discounts, rebates and refunds and all returns from sale of surplus materials and equipment shall accrue to OWNER, and CONTRACTOR shall make provisions so that they may be obtained.

10.4.3 Subcontractor Costs

Payments made by CONTRACTOR to the Subcontractors for Work performed by Subcontractors. If required by OWNER, CONTRACTOR shall obtain competitive bids from Subcontractors acceptable to CONTRACTOR and shall deliver such bids to OWNER who will then determine, with the advice of CONSULTANT, which bids will be accepted. If a subcontract provides that the Subcontractor is to be paid on the basis of Cost of the Work Plus a Fee, the Subcontractor's Cost of the Work shall be determined in the same manner as CONTRACTOR'S Cost of the Work. All subcontracts shall be subject to the other provisions of the Contract Documents insofar as applicable.

10.4.4 Special Consultant Costs

Costs of special consultants (including but not limited to engineers, architects, testing laboratories, surveyors, attorneys and accountants) employed for services specifically related to the Work.

10.4.5 Supplemental Costs

10.4.5.1 The proportion of necessary transportation, travel and subsistence expenses of CONTRACTOR'S employees incurred in discharge of duties connected with the Work.

10.4.5.2 Cost, including transportation and maintenance, of all materials, supplies, equipment, machinery,

appliances, office and temporary facilities at the site and hand tools not owned by the workers, which are consumed in the performance of the Work, and cost less market value of such items used but not consumed which remain the property of CONTRACTOR.

10.4.5.3 Rentals of all construction equipment and machinery and the parts thereof whether rented from CONTRACTOR or others in accordance with rental agreements approved by OWNER with the advice of CONSULTANT, and the costs of transportation, loading, unloading, installation, dismantling and removal shall be in accordance with terms of said rental agreements. The rental of any such equipment, machinery or parts shall cease when the use thereof is no longer necessary for the Work.

10.4.5.4 Sales, consumer, use or similar taxes related to the Work, and for which CONTRACTOR is liable, imposed by Laws and Regulations.

10.4.5.5 Deposits lost for causes other than negligence of CONTRACTOR, any Subcontractor or anyone directly or indirectly employed by any of them or for whose acts any of them may be liable, and royalty payments and fees for permits and licenses.

10.4.5.6 Losses and damages (and related expenses), not compensated by insurance or otherwise, to the Work or otherwise sustained by CONTRACTOR in connection with the performance and furnishing of the Work (except losses and damages within the deductible amounts of property insurance established by OWNER), provided they have resulted from causes other than the negligence of CONTRACTOR, any Subcontractor, or anyone directly or indirectly employed by any of them or for whose acts any of them may be liable. Such losses shall include settlements made with the written consent and approval of OWNER. No such losses, damages and expenses shall be included in the Cost of the Work for the purpose of determining CONTRACTOR'S fee. If, however, any such loss or damage requires reconstruction and CONTRACTOR is placed in charge thereof, CONTRACTOR shall be paid a fee proportionate to that stated in paragraph 10.6.2 for services.

10.4.5.7 The cost of utilities, fuel and sanitary facilities at the site.

10.4.5.8 Minor expenses such as telegrams, long distance telephone calls, telephone service at the site, expressage and similar petty cash items in connection with the Work.

10.4.5.9 Cost of premiums for additional Bonds and insurance required because of changes in the Work and premiums for property insurance coverage within the limits of the deductible amounts established by OWNER.

10.5 Not to Be Included in Cost of the Work

The term Cost of the Work shall not include any of the following:

10.5.1 Costs of Officers and Executives

Payroll costs and other compensation of CONTRACTOR'S officers, executives, principals (of partnership and sole proprietorships), general managers, engineers, architects, estimators, attorneys, auditors, accountants, purchasing and contracting agents, expeditors, timekeepers, clerks and other personnel employed by CONTRACTOR whether at the site or in CONTRACTOR'S principal or a branch office for general administration of the Work and not specifically included in the agreed upon schedule of job classifications referred to in paragraph 10.4.1 or specifically covered by paragraph 10.4.4 - all of which are to be considered administrative costs covered by the CONTRACTOR'S fee.

10.5.2 Principal Office

Expenses of CONTRACTOR'S principal and branch offices other than CONTRACTOR'S office at the site.

10.5.3 Capital Expense

Any part of CONTRACTOR'S capital expenses, including interest on CONTRACTOR'S capital employed for the Work and charges against CONTRACTOR for delinquent payments.

10.5.4 Bonds and Insurance

Cost of premiums for all Bonds and for all insurance whether or not CONTRACTOR is required by the Contract Documents to purchase and maintain the same (except for the cost of premiums covered by subparagraph 10.4.5.9 above).

10.5.5 Costs Due to Negligence

Costs due to the negligence of CONTRACTOR, any Subcontractor, or anyone directly or indirectly employed by any of them or for whose acts any of them may be liable, including but not limited to, the correction of defective Work, disposal of materials or equipment wrongly supplied and making good any damage to property.

10.5.6 Other Costs

Other overhead or general expense costs of any kind and the costs of any item not specifically and expressly included in paragraph 10.4.

10.6 Contractor's Fee

The CONTRACTOR'S Fee allowed to CONTRACTOR for overhead and profit shall be determined as follows:

10.6.1 a mutually acceptable fixed fee; or if none can be agreed upon,

10.6.2 a fee based on the following percentages of the various portions of the Cost of the Work:

10.6.2.1 for costs incurred under paragraphs 10.4.1 and 10.4.2, the CONTRACTOR'S fee shall be fifteen percent;

10.6.2.2 for costs incurred under paragraph 10.4.3, the CONTRACTOR'S fee shall be five percent; and if a subcontract is on the basis of Cost of the Work Plus a fee, the maximum allowable to CONTRACTOR on account of overhead and profit of all Subcontractors shall be fifteen percent;

10.6.2.3 no fee shall be payable on the basis of costs itemized under paragraphs 10.4.4, 10.4.5 and 10.5;

10.6.2.4 the amount of credit to be allowed by CONTRACTOR to OWNER for any such change which results in a net decrease in cost will be the amount of the actual net decrease plus a deduction in CONTRACTOR'S Fee by an amount equal to ten percent of the net decrease; and

10.6.2.5 when both additions and credits are involved in any one change, the adjustment in CONTRACTOR'S fee shall be computed on the basis of the net change in accordance with paragraphs 10.6.2.1 through 10.6.2.4, inclusive.

10.7 Itemized Cost Breakdown

Whenever the cost of any Work is to be determined pursuant to paragraph 10.4 or 10.5, CONTRACTOR will submit in form acceptable to CONSULTANT an itemized cost breakdown together with supporting data.

10.8 Cash Allowances

It is understood that CONTRACTOR has included in the Contract Price all allowances so named in the Contract Documents and shall cause the Work so covered to be done by such Subcontractors or Suppliers and for such sums within the limit of the allowances as may be acceptable to CONSULTANT, CONTRACTOR agrees that:

10.8.1 Materials and Equipment

The allowances include the cost to CONTRACTOR (less any applicable trade discounts) of materials and equipment required by the allowances to be delivered at the site, and all applicable taxes; and

10.8.2 Other Costs

CONTRACTOR'S costs for unloading and handling on the site, labor, installation costs, overhead, profit and other expenses contemplated for the allowances have been included in the Contract Price and not in the allowances. No demand for additional payment on account of any thereof will be valid.

10.8.3 Change Order

Prior to final payment, an appropriate Change Order will be issued as recommended by CONSULTANT to reflect actual amounts due CONTRACTOR on account of Work covered by allowances, and the Contract Price shall be correspondingly adjusted.

10.9 Unit Price Work

10.9.1 General

Where the Contract Documents provide that all or part of the Work is to be Unit Price Work, initially the Contract Price will be deemed to include for all Unit Price Work an amount equal to the sum of the established unit prices for each separately identified item of Unit Price Work times the estimated quantity of each item as indicated in the Agreement. The estimated quantities of items of Unit Price Work are not guaranteed and are solely for the purpose of comparison of Bids and determining an initial Contract Price. Determinations of the actual quantities and classifications of Unit Price Work performed by CONTRACTOR will be made by CONSULTANT in accordance with Paragraph 8.10.

10.9.2 Overhead and Profit

Each unit price will be deemed to include an amount considered by CONTRACTOR to be adequate to cover CONTRACTOR'S overhead and profit for each separately identified item.

10.9.3 Claim for Increase in Unit Price

Where the quantity of any item of Unit Price Work performed by CONTRACTOR differs materially and significantly from the estimated quantity of such item indicated in the Agreement and there is no corresponding adjustment with respect to any other item of Work and if CONTRACTOR believes that CONTRACTOR has incurred additional expense as a result thereof, CONTRACTOR may make a claim for an increase in the Contract Price in accordance with Article 10.

11. CHANGE OF CONTRACT TIME

11.1 Change Order

The Contract Time may only be changed by a Change Order. Any claim for an extension or shortening of the Contract Time shall be based on written notice delivered to CONSULTANT promptly (but in no event later than thirty days) after the occurrence of the event giving rise to the claim and stating the general nature of the claim. Notice of the extent of the claim with supporting data shall be delivered within sixty days after such occurrence (unless CONSULTANT allows an additional period of time to ascertain more accurate data in support of the claim) and shall be accompanied by the claimant's written statement that the adjustment claimed is the entire adjustment to which the claimant has reason to believe it is entitled as a result of the occurrence of said event. All claims for adjustment in the Contract Time shall be determined by CONSULTANT in accordance with paragraph 8.11. No claim for an adjustment in the Contract Time will be valid if not submitted in accordance with the requirements of this paragraph 11.1.

11.2 Justification for Time Extensions

The Contract Time will be extended in an amount equal to time lost due to delays beyond the control of CONTRACTOR if a claim is made therefore as provided in paragraph 11.1. Such delays shall include, but not be limited to, acts or neglect by OWNER or others performing additional work as contemplated by Article 6, or to fires, floods, labor disputes, epidemics, abnormal weather conditions or acts of God.

11.3 Time Limits

All time limits stated in the Contract Documents are of the essence of the Agreement. The provisions of this Article 11 shall not exclude recovery for damages (including but not limited to fees and charges of engineers, architects, attorneys and other professionals and court costs) for delay by either party.

12. WARRANTY AND GUARANTEE; TESTS AND INSPECTIONS; CORRECTION, REMOVAL OR ACCEPTANCE OF DEFECTIVE WORK

12.1 Warranty and Guarantee

CONTRACTOR warrants and guarantees to OWNER and CONSULTANT that all Work will be in accordance with the Contract Documents and will not be defective. All defective Work, whether or not in place, may be rejected, corrected or accepted as provided in this Article 12.

12.2 Access to Work

CONSULTANT and CONSULTANT'S representatives, other representatives of OWNER, testing agencies and governmental agencies with jurisdictional interests will have access to the Work at reasonable times for their observation, inspecting and testing. CONTRACTOR shall provide proper and safe conditions for such access.

12.3 Tests and Inspections

12.3.1 Timely Notice

CONTRACTOR shall give CONSULTANT timely notice of readiness of the Work for all required inspections, tests or approvals.

12.3.2 Requirements and Responsibilities

The CONSULTANT may require such inspection and testing during the course of the Work as he/she deems necessary to ascertain and assure the integrity and acceptable quality of the materials incorporated and the work performed. Inspection presence may be either full-time or intermittent, and neither the presence nor absence at any time of the CONSULTANT or the INSPECTOR shall relieve the CONTRACTOR of sole responsibility for the acceptability and integrity of the Work or any part thereof.

The costs of sampling, testing, and inspection on-site to ascertain acceptability of the Work and materials will be borne by the OWNER except as otherwise provided. The OWNER will select a testing laboratory to perform such sampling and testing. Sampling and/or testing required by the CONTRACTOR or necessitated by failure of Work or materials to meet the above acceptability test shall be at the expense of the CONTRACTOR.

Inspection services may be performed by the employees of the OWNER or by others selected or designated by the OWNER or the CONSULTANT.

Sampling and/or testing required for manufacturing quality and/or process control, for certification that raw mineral materials or manufactured products are the quality specified in the contract, or to assure the acceptability for incorporation into the Work shall be borne by the CONTRACTOR or the material supplier.

Cost for inspection, sampling, testing, and approvals required by the laws or regulations of any public body having competent jurisdiction shall be borne by the CONTRACTOR or the material supplier.

Sampling and testing will be in accord with pertinent codes and regulations and with appropriate standards of the American Society of Testing Materials or other specified standards.

12.3.3 On-Site Construction Test and Other Testing

All inspections, tests or approvals other than those required by Laws or Regulations of any public body having jurisdiction shall be performed by organizations acceptable to OWNER and CONTRACTOR (or by CONSULTANT if so specified).

12.3.4 Covered Work

If any Work (including the work of others) that is to be inspected, tested or approved is covered without written concurrence of CONSULTANT, it must, if requested by CONSULTANT, be uncovered for observation. Such uncovering shall be at CONTRACTOR'S expense unless CONTRACTOR has given CONSULTANT timely notice of CONTRACTOR'S intention to cover the same and CONSULTANT has not acted with reasonable promptness in response to such notice.

12.3.5 CONTRACTOR'S Obligation

Neither observations by CONSULTANT nor inspections, tests or approvals by others shall relieve CONTRACTOR from CONTRACTOR'S obligations to perform the Work in accordance with the Contract Documents.

12.4 OWNER May Stop the Work

If the Work is defective, or CONTRACTOR fails to supply sufficient skilled workers or suitable materials or equipment, or fails to furnish or perform the Work in such a way that the completed Work will conform to the Contract Documents, OWNER may order CONTRACTOR to stop the Work, or any portion thereof, until the cause for such order has been eliminated; however, this right of OWNER to stop the Work shall not give rise to any duty on the part of OWNER to exercise this right for the benefit of CONTRACTOR or any other party.

12.5 Correction or Removal of Defective Work

If required by CONSULTANT, CONTRACTOR shall promptly, as directed, either correct all defective Work, whether or not fabricated, installed or completed, or, if the Work has been rejected by CONSULTANT, remove it from the site and replace it with non-defective Work. CONTRACTOR shall bear all direct, indirect and consequential costs of such correction or removal (including but not limited to fees and charges of engineers, architects, attorneys and other professionals) made necessary thereby.

12.6 One Year Correction Period

If within one year after the date of Completion or such longer period of time as may be prescribed by Laws or Regulations or by the terms of any applicable special guarantee required by the Contract Documents or by any specific provision of the Contract Documents, any Work is found to be defective, CONTRACTOR shall promptly, without cost to OWNER and in accordance with OWNER'S written instructions, either correct such defective Work, or, if it has been rejected by OWNER, remove it from the site and replace it with non-defective Work. If CONTRACTOR does not promptly comply with the terms of such instructions, or in an emergency where delay would cause serious risk of loss or damage, OWNER may have the defective Work corrected or the rejected Work removed and replaced, and all direct, indirect and consequential costs of such removal and replacement (including but not limited to fees and charges of engineers, architects, attorneys and other professionals)

will be paid by CONTRACTOR. In special circumstances where a particular item of equipment is placed in continuous service before Completion of all the Work, the correction period for that item may start to run from an earlier date if so provided in the Specifications or by Change Order.

12.7 Acceptance of Defective Work

If, instead of requiring correction or removal and replacement of defective Work, OWNER prefers to accept it, OWNER may do so. CONTRACTOR shall bear all direct, indirect and consequential costs attributable to OWNER'S evaluation of and determination to accept such defective Work (such costs to be approved by CONSULTANT as to reasonableness and to include but not be limited to fees and charges of engineers, architects, attorneys and other professionals).

12.8 OWNER May Correct Defective Work

If CONTRACTOR fails within a reasonable time after written notice of CONSULTANT to proceed to correct and to correct defective Work or to remove and replace rejected Work as required by CONSULTANT in accordance with paragraph 12.5, or if CONTRACTOR fails to perform the Work in accordance with the Contract Documents, or if CONTRACTOR fails to comply with any other provision of the Contract Documents, OWNER may, after seven days' written notice to CONTRACTOR, correct and remedy any such deficiency. In exercising the rights and remedies under this paragraph OWNER shall proceed expeditiously. To the extent necessary to complete corrective and remedial action, OWNER may exclude CONTRACTOR from all or part of the site, take possession of all or part of the Work, and suspend CONTRACTOR'S services related thereto, take possession of CONTRACTOR'S tools, appliances, construction equipment and machinery at the site and incorporate in the Work all materials and equipment stored at the site or for which OWNER has paid CONTRACTOR but which are stored elsewhere. CONTRACTOR shall allow OWNER, OWNER'S representatives, agents and employees such access to the site as may be necessary to enable OWNER to exercise the rights and remedies under this paragraph. All direct, indirect and consequential costs of OWNER in exercising such rights and remedies will be charged against CONTRACTOR in an amount approved as to reasonableness by CONSULTANT, and a Change Order will be issued incorporating the necessary revisions in the Contract Documents with respect to the Work; and OWNER shall be entitled to an appropriate decrease in the Contract Price. Such direct, indirect and consequential costs will include but not be limited to fees and charges of engineers, architects, attorneys and other professionals, all court costs and all costs of repair and replacement of work of others destroyed or damaged by correction, removal or replacement of CONTRACTOR'S defective Work. CONTRACTOR shall not be allowed an extension of the Contract Time because of any delay in performance of the Work attributable to the exercise by OWNER of OWNER'S rights and remedies hereunder.

13. PAYMENTS TO CONTRACTOR AND COMPLETION

13.1 Schedule of Values

The schedule of values established as provided in paragraph 2.8 will serve as the basis for progress payments and will be incorporated into a form of Application for Payment acceptable to CONSULTANT. Progress payments on account of Unit Price Work will be based on the number of units completed.

13.2 Application for Progress Payment

At least ten days before each progress payment is scheduled (but not more often than once a month), CONTRACTOR shall submit to CONSULTANT for review an Application for Payment filled out and signed by CONTRACTOR covering the Work completed as of the date of the Application and accompanied by such supporting documentation as is required by the Contract Documents. If payment is requested on the basis of materials and equipment not incorporated in the Work but delivered and suitably stored at the site or at another location agreed to in writing, the Application for Payment shall also be accompanied by a bill of sale, invoice or other documentation warranting that OWNER has received the materials and equipment free and clear of all liens, charges, security interests and encumbrances (which are hereinafter in these General Conditions referred to as "Liens") and evidence that the materials and equipment are covered by appropriate property insurance and other arrangements to protect OWNER'S interest therein, all of which will be satisfactory to OWNER. OWNER shall, within thirty (30) calendar days of presentation to him of an approved Application for Payment, pay CONTRACTOR the amount approved by CONSULTANT. Monthly progress payments shall be ninety (90) percent of the sum obtained by applying the respective bid unit prices to the approved estimated quantities of work completed by the Contractor during the preceding month. The remaining ten (10) percent will be held by the Owner, as retainage. At such time as the CONSULTANT deems appropriate - based on the quality of work performed, progress of cleanup, and other pertinent factors - the rate of retainage, or the total amount retained, may be reduced; although, any reduction in retainage, below the ten (10) percent level, is made solely at the CONSULTANT's discretion. All remaining retainage held will be included in the final payment to the Contractor.

13.2.1 Waivers of Mechanic's Lien

With each Application for Payment OWNER may require CONTRACTOR to submit waivers of mechanic's lien from entities lawfully entitled to file a mechanic's lien arising out of the Contract and related to the Work covered by the payment.

13.2.1.1 Requirement for waivers of Mechanic's Lien on Partial Applications for Payment will be determined and communicated at the Preconstruction Conference.

13.2.1.2 Submit partial waivers on each item for amount requested in previous application, after deduction for retainage, on each item.

13.2.1.3 When an application shows completion of an item, submit conditional final or full waivers.

13.2.1.4 Owner reserves the right to designate which entities involved in the Work must submit waivers.

13.2.1.5 Waiver Forms: Submit executed waivers of lien on forms acceptable to Owner.

13.3 CONTRACTOR'S Warranty of Title

CONTRACTOR warrants and guarantees that title to all Work, materials and equipment covered by any Application for Payment, whether incorporated in the Project or not, will pass to OWNER no later than the time of payment free and clear of all Liens.

13.4 Review of Applications for Progress Payment

13.4.1 Submission of Application for Payment

CONSULTANT will, after receipt of each Application for Payment, either indicate in writing a recommendation of payment and present the Application to OWNER, or return the Application to CONTRACTOR indicating in writing CONSULTANT'S reasons for refusing to recommend payment. In the latter case, CONTRACTOR may make the necessary corrections and resubmit the Application.

13.4.2 CONSULTANT'S Recommendation

CONSULTANT may refuse to recommend the whole or any part of any payment, if, in CONSULTANT'S opinion, it would be incorrect to make such representations to OWNER. CONSULTANT may also refuse to recommend any such payment, or, because of subsequently discovered evidence or the results of subsequent inspections or tests, nullify any such payment previously recommended, to such extent as may be necessary in CONSULTANT'S opinion to protect OWNER from loss because:

13.4.2.1 the Work is defective, or completed Work has been damaged requiring correction or replacement;

13.4.2.2 the Contract Price has been reduced by Written Amendment or Change Order;

13.4.2.3 OWNER has been required to correct defective Work or complete Work in accordance with paragraph 12.8; or

13.4.2.4 of CONSULTANT's actual knowledge of the occurrence of any of the events enumerated in paragraphs 14.2.1 through 14.2.9 inclusive.

13.5 Partial Utilization

OWNER at any time may request CONTRACTOR in writing to permit OWNER to use any such part of the Work which OWNER believes to be ready for its intended use and has been completed. If CONTRACTOR agrees, CONTRACTOR will certify to OWNER that said part of the Work is complete and request that a Certificate of Completion be issued for that part of the Work.

13.6 Final Inspection

Upon written notice from CONTRACTOR that the entire Work or an agreed portion thereof is complete, CONSULTANT will make a final inspection with CONTRACTOR and will notify CONTRACTOR in writing of all particulars in which this inspection reveals that the Work is incomplete or defective. CONTRACTOR shall immediately take such measures as are necessary to remedy such deficiencies.

13.7 Final Application for Payment

After CONTRACTOR has completed all such corrections to the satisfaction of CONSULTANT and delivered all maintenance and operating instructions, schedules, guarantees, Bonds, certificates of inspection, marked-up record documents (as provided in paragraph 5.14) and other documents - all as required by the Contract Documents, and after CONSULTANT has indicated that the Work is acceptable (subject to the provisions of paragraph 13.10), CONTRACTOR may make application for final payment following the procedure for progress payments. The final Application for Payment shall be accompanied by all documentation called for in the Contract Documents, together with complete and legally effective releases or waivers (satisfactory to OWNER) of all Liens arising out of or filed in connection with the Work. In lieu thereof and as approved by OWNER, CONTRACTOR may furnish receipts or releases in full; an affidavit of CONTRACTOR that the releases and receipts include all labor, services, material and equipment for which a Lien could be filed, and that all payrolls, material and equipment bills, and other indebtedness connected with the Work for which OWNER or OWNER'S property might in any way be responsible, have been paid or otherwise satisfied; and consent of the surety, if any, to final payment. If any Subcontractor or Supplier fails to furnish a release or

receipt in full, CONTRACTOR may furnish a Bond or other collateral satisfactory to OWNER to indemnify OWNER against any Lien.

13.8 Final Payment and Acceptance

13.8.1 CONSULTANT'S Approval

If, on the basis of CONSULTANT'S observation of the Work during construction and final inspection, and CONSULTANT'S review of the final Application for Payment and accompanying documentation - all as required by the Contract Documents, CONSULTANT is satisfied that the Work has been completed and CONTRACTOR'S other obligations under the Contract Documents have been fulfilled, CONSULTANT will, after receipt of the final Application for Payment, indicate in writing CONSULTANT'S recommendation of payment and present the Application to OWNER for payment. Thereupon CONSULTANT will give written notice to OWNER and CONTRACTOR that the Work is acceptable, subject to the provisions of paragraph 13.10. Otherwise, CONSULTANT will return the Application to CONTRACTOR, indicating in writing the reasons for refusing to recommend final payment, in which case CONTRACTOR shall make the necessary corrections and resubmit the Application.

13.8.2 Delay in Completion of Work

If, through no fault of CONTRACTOR, final completion of the Work is significantly delayed, OWNER shall, upon receipt of CONTRACTOR'S final Application for Payment and recommendation of CONSULTANT, and without terminating the Agreement, make payment of the balance due for that portion of the Work fully completed and accepted. If the remaining balance to be held by OWNER for Work not fully completed or corrected is less than the retainage stipulated in the Agreement, and if Bonds have been furnished as required in paragraph 10 of Part II, Information for Bidders, the written consent of the surety to the payment of the balance due for that portion of the Work fully completed and accepted shall be submitted by CONTRACTOR to CONSULTANT with the Application for such payment. Such payment shall be made under the terms and conditions governing final payment, except that it shall not constitute a waiver of claims.

13.8.3 Retainage

Retainage is not applicable to this project.

13.9 CONTRACTOR'S Continuing Obligation

CONTRACTOR'S obligation to perform and complete the Work in accordance with the Contract Documents shall be absolute. Neither recommendation of any progress or final payment by CONSULTANT, nor the issuance of a certificate of Completion, nor any payment by OWNER to CONTRACTOR under the Contract Documents, nor any use or occupancy of the Work or any part thereof by OWNER, nor any act of acceptance by OWNER nor any failure to do so, nor any review and approval of a

Shop Drawing or sample submission, nor any correction of defective Work by OWNER will constitute an acceptance of Work not in accordance with the Contract Documents or a release of CONTRACTOR'S obligation to perform the Work in accordance with the Contract Documents (except as provided in paragraph 13.10).

13.10 Waiver of Claims

The making and acceptance of final payment will constitute:

13.10.1 a waiver of all claims by OWNER against CONTRACTOR, except claims arising from unsettled Liens, from defective Work appearing after final inspection or from failure to comply with the Contract Documents or the terms of any special guarantees specified therein; however, it will not constitute a waiver by OWNER of any rights in respect of CONTRACTOR'S continuing obligations under the Contract Documents; and

13.10.2 a waiver of all claims by CONTRACTOR against OWNER other than those previously made in writing and still unsettled.

14. SUSPENSION OF WORK AND TERMINATION

14.1 OWNER May Suspend Work

OWNER may, at any time and without cause, suspend the Work or any portion thereof for a period of not more than ninety days by notice in writing to CONTRACTOR and CONSULTANT which will fix the date on which Work will be resumed. CONTRACTOR shall resume the Work on the date so fixed. CONTRACTOR shall be allowed an increase in the Contract Price or an extension of the Contract Time, or both, directly attributable to any suspension if CONTRACTOR makes an approved claim therefor as provided in Articles 10 and 11.

14.2 OWNER May Terminate

The OWNER may terminate the Work upon the occurrence of any one or more of the following events:

14.2.1 if CONTRACTOR commences a voluntary case under any chapter of the Bankruptcy Code (Title 11, United States Code), as now or hereafter in effect, or if CONTRACTOR takes any equivalent or similar action by filing a petition or otherwise under any other federal or state law in effect at such time relating to the bankruptcy or insolvency;

14.2.2 if a petition is filed against CONTRACTOR under any chapter of the Bankruptcy Code as now or hereafter in effect at the time of filing, or if a petition is filed seeking any such equivalent or similar relief against CONTRACTOR under any other federal or state law in effect at the time relating to bankruptcy or insolvency;

14.2.3 if CONTRACTOR makes a general assignment for the benefit of creditors;

14.2.4 if a trustee, receiver, custodian or agent of CONTRACTOR is appointed under applicable law or under contract, whose appointment or authority to take charge of property of CONTRACTOR is for the purpose of enforcing a Lien against such property or for the purpose of general administration of such property for the benefit of CONTRACTOR'S creditors;

14.2.5 if CONTRACTOR admits in writing an inability to pay its debts generally as they become due;

14.2.6 if CONTRACTOR persistently fails to perform the Work in accordance with the Contract Documents (including, but not limited to, failure to supply sufficient skilled workers or suitable materials or equipment or failure to adhere to the progress schedule established under paragraph 2.8 as revised from time to time);

14.2.7 if CONTRACTOR disregards Laws or Regulations of any public body having jurisdiction;

14.2.8 if CONTRACTOR disregards the authority of CONSULTANT, or

14.2.9 if CONTRACTOR otherwise violates in any substantial way any provisions of the Contract Documents;

OWNER may, after giving CONTRACTOR (and the surety) seven days' written notice and to the extent permitted by Laws and Regulations, terminate the services of CONTRACTOR, exclude CONTRACTOR from the site and take possession of the Work and of all CONTRACTOR'S tools, appliances, construction equipment and machinery at the site and use the same to the full extent they could be used by CONTRACTOR (without liability to CONTRACTOR for trespass or conversion), incorporate in the Work all materials and equipment stored at the site or for which OWNER has paid CONTRACTOR but which are stored elsewhere, and finish the Work as OWNER may deem expedient. In such case CONTRACTOR shall not be entitled to receive any further payment until the Work is finished. If the unpaid balance of the Contract Price exceeds the direct, indirect and consequential costs of completing the Work (including but not limited to fees and charges of engineers, architects, attorneys and other professionals and court and arbitration costs) such excess will be paid to CONTRACTOR. If such costs exceed such unpaid balance, CONTRACTOR shall pay the difference to OWNER. Such costs incurred by OWNER will be approved as to reasonableness by CONSULTANT and incorporated in a Change Order, but

when exercising any rights or remedies under this paragraph OWNER shall not be required to obtain the lowest price for the Work performed.

14.2.10 If safety violations are observed and brought to the Contractor's attention and Contractor fails to take immediate corrective measures any repeat of similar safety violations, Owner will order an immediate termination of contract. Note: it is the Contractor's responsibility to know proper safety measures as they pertain to construction and OSHA.

14.2.11 This contract may be canceled by either party thirty (30) days after delivery by canceling party of written notice of intent to cancel to the other contracting party.

14.2.12 This contract may be canceled by the Lexington-Fayette Urban County Government if it is determined that the Bidder has failed to perform under the terms of this agreement, such cancellation to be effective upon receipt of written notice of cancellation by the Bidder.

14.3 CONTRACTOR'S Services Terminated

Where CONTRACTOR'S services have been so terminated by OWNER, the termination will not affect any rights or remedies of OWNER against CONTRACTOR then existing or which may thereafter accrue. Any retention or payment of moneys due CONTRACTOR by OWNER will not release CONTRACTOR from liability.

14.4 Payment After Termination

Upon seven days' written notice to CONTRACTOR, OWNER may, without cause and without prejudice to any other right or remedy, elect to abandon the Work and terminate the Agreement. In such case, CONTRACTOR shall be paid for all Work executed and any expense sustained plus reasonable termination expenses, which will include, but not be limited to, direct, indirect and consequential costs (including, but not limited to, fees and charges of engineers, architects, attorneys and other professionals and court and arbitration costs).

14.5 CONTRACTOR May Stop Work or Terminate

If, through no act or fault of CONTRACTOR, the Work is suspended for a period of more than ninety days by OWNER or under an order of court or other public authority, or CONSULTANT fails to act on any Application for Payment within sixty days after it is submitted, or OWNER fails for sixty days to pay CONTRACTOR any sum finally determined to be due, then CONTRACTOR may, upon seven days' written notice to OWNER and CONSULTANT, terminate the Agreement and recover from OWNER payment for all Work executed and any expense sustained plus reasonable termination expenses. In addition and in lieu of terminating the Agreement, if CONSULTANT has failed to act on an Application for Payment or OWNER has failed to make any payment as aforesaid, CONTRACTOR may upon seven days' written notice to OWNER and CONSULTANT stop the Work until payment of all amounts then due.

The provisions of this paragraph shall not relieve CONTRACTOR of the obligations under paragraph 5.16 to carry on the Work in accordance with the progress schedule and without delay during disputes and disagreements with OWNER.

15. MISCELLANEOUS

15.1 Claims for Injury or Damage

Should OWNER or CONTRACTOR suffer injury or damage to person or property because of any error, omission or act of the other party or of any of the other party's employees or agents or others for whose acts the other party is legally liable, claim will be made in writing to the other party within a reasonable time of the first observance of such injury or damage. The provisions of this paragraph 15.1 shall not be construed as a substitute for or a waiver of the provisions of any applicable statute of limitations or repose.

15.2 Non-Discrimination in Employment

The CONTRACTOR shall comply with the following requirements prohibiting discrimination:

15.2.1 That no person (as defined in KRS 344.010) shall bid on Lexington-Fayette Urban County Government construction projects, or bid to furnish materials or supplies to the Lexington-Fayette Urban County Government, if, within six months prior to the time of opening of bids, said person shall have been found, by declaratory judgment action in Fayette Circuit Court, to be presently engaging in an unlawful practice, as hereinafter defined. Such declaratory judgment action may be brought by an aggrieved individual or upon an allegation that an effort at conciliation pursuant to KRS 344.200 has been attempted and failed, by the Lexington-Fayette County Human Rights Commission.

15.2.2 That it is an unlawful practice for an employer:

15.2.2.1 to fail or refuse to hire, or to discharge any individual or otherwise to discriminate against an individual, with respect to his compensation, terms, conditions, or privileges of employment, because of such individual's race, color, religion, sex, age, or national origin; or

15.2.2.2 to limit, segregate or classify his employees in any way which would deprive or tend to deprive an individual of employment opportunities or otherwise adversely affect his status as an employee because of such individual's sex, race, color, religion, age, or national origin.

15.2.3 That it is an unlawful practice for an employer, labor organization, or joint-labor management committee controlling apprenticeship or other

training or retraining, including on-the-job training programs to discriminate against an individual because of his race, color, religion, sex, age, or national origin in admission to, or employment in, any program established to provide apprenticeship or other training.

15.2.4 That a copy of this Ordinance shall be furnished all suppliers and made a part of all bid specifications.

15.2.5 This Ordinance shall take effect after it is signed, published and recorded, as required by law.

15.3 Temporary Street Closing or Blockage

The CONTRACTOR will notify the CONSULTANT at least 72 hours prior to making any temporary street closing or blockage. This will permit orderly notification to all concerned public agencies. Specific details and restrictions on street closure or blockage are contained in the Special Conditions.

15.4 Percentage of Work Performed by prime CONTRACTOR

The CONTRACTOR shall perform on site, and with its own organization, Work equivalent to at least fifty (50%) percent of the total amount of Work to be performed under the Contract. This percentage may be reduced by a supplemental agreement to this Contract if, during performing the Work, the CONTRACTOR requests a reduction and the CONSULTANT determines that the reduction would be to the advantage of the OWNER.

15.5 Clean-up

Cleanup shall progress, to the greatest degree practicable, throughout the course of the Work. The Work will not be considered as completed, and final payment will not be made, until the right-of-way and all ground occupied or affected by the Contractor in connection with the Work has been cleared of all rubbish, equipment, excess materials, temporary structures, and weeds. Rubbish and all waste materials of whatever nature shall be disposed of, off of the project site, in an acceptable manner. All property, both public and private, which has been damaged in the prosecution of the Work, shall be restored in an acceptable manner. All areas shall be draining, and all drainage ways shall be left unobstructed, and in such a condition that drift will not collect or scour be induced.

15.6 General

The duties and obligations imposed by these General Conditions and the rights and remedies available hereunder to the parties hereto, and, in particular but without limitation, the warranties, guarantees and obligations imposed upon CONTRACTOR by paragraphs 12.1, 12.3.5, 13.3, and 15.2 and all of the rights and remedies available to OWNER and CONSULTANT thereunder, are in addition to, and are not to be construed in any way as a limitation of, any rights and remedies available to any or all of them which are otherwise imposed or available by Laws or Regulations, by special warranty or guarantee or by other provisions of the Contract Documents, and the

provisions of this paragraph will be as effective as if repeated specifically in the Contract Documents in connection with each particular duty, obligation, right and remedy to which they apply. All representations, warranties and guarantees made in the Contract Documents will survive final payment and termination or completion of the Agreement.

15.7 Debris Disposal

For all LFUCG projects any trash, construction demolition debris, yard waste, dirt or debris of any kind that is removed from the project site must be disposed of in accordance with local, state, and federal regulations. The disposal site or facility must be approved in advance by the LFUCG and disposal documentation is required. The Contractor will be responsible for payment of any fines associated with improper disposal of material removed from the project site.

END OF SECTION

PART V
SPECIAL CONDITIONS
INDEX

- 1 BLASTING
- 2 RISK MANAGEMENT PROVISIONS –
INSURANCE AND INDEMNIFICATION
- 3 WAGE SCALE
- 4 WEATHER RELATED DELAYS

1. **BLASTING** – not applicable.

2. **RISK MANAGEMENT PROVISIONS**
INSURANCE AND INDEMNIFICATION

INDEMNIFICATION AND HOLD HARMLESS PROVISION

(1) It is understood and agreed by the parties that Contractor hereby assumes the entire responsibility and liability for any and all damages to persons or property caused by or resulting from or arising out of any act or omission on the part of Contractor or its employees, agents, servants, owners, principals, licensees, assigns or subcontractors of any tier (hereinafter "CONTRACTOR") under or in connection with this agreement and/or the provision of goods or services and the performance or failure to perform any work required thereby.

(2) CONTRACTOR shall indemnify, save, hold harmless and defend the Lexington-Fayette Urban County Government and its elected and appointed officials, employees, agents, volunteers, and successors in interest (hereinafter "LFUCG") from and against all liability, damages, and losses, including but not limited to, demands, claims, obligations, causes of action, judgments, penalties, fines, liens, costs, expenses, interest, defense costs and reasonable attorney's fees that are in any way incidental to or connected with, or that arise or are alleged to have arisen, directly or indirectly, from or by CONTRACTOR's performance or breach of the agreement and/or the provision of goods or services provided that: (a) it is attributable to personal injury, bodily injury, sickness, or death, or to injury to or destruction of property (including the loss of use resulting therefrom), or to or from the negligent acts, errors or omissions or willful misconduct of the CONTRACTOR; and (b) not caused solely by the active negligence or willful misconduct of LFUCG.

(3) In the event LFUCG is alleged to be liable based upon the above, CONTRACTOR shall defend such allegations and shall bear all costs, fees and expenses of such defense, including but not limited to, all reasonable attorneys' fees and expenses, court costs, and expert witness fees and expenses, using attorneys approved in writing by LFUCG, which approval shall not be unreasonably withheld.

(4) These provisions shall in no way be limited by any financial responsibility or insurance requirements, and shall survive the termination of this agreement.

(5) LFUCG is a political subdivision of the Commonwealth of Kentucky. CONTRACTOR acknowledges and agrees that LFUCG is unable to provide indemnity or otherwise save, hold harmless, or defend the CONTRACTOR in any manner.

FINANCIAL RESPONSIBILITY

BIDDER/CONTRACTOR understands and agrees that it shall, prior to final acceptance of its bid and the commencement of any work, demonstrate the ability to assure compliance with the above Indemnity provisions and these other risk management provisions.

INSURANCE REQUIREMENTS

YOUR ATTENTION IS DIRECTED TO THE INSURANCE REQUIREMENTS BELOW, AND YOU MAY NEED TO CONFER WITH YOUR INSURANCE AGENTS, BROKERS, OR CARRIERS TO DETERMINE IN ADVANCE OF SUBMISSION OF A RESPONSE THE AVAILABILITY OF THE INSURANCE COVERAGES AND ENDORSEMENTS REQUIRED HEREIN. IF YOU FAIL TO COMPLY WITH THE INSURANCE REQUIREMENTS BELOW, YOU MAY BE DISQUALIFIED FROM AWARD OF THE CONTRACT.

Required Insurance Coverage

BIDDER/CONTRACTOR shall procure and maintain for the duration of this contract the following or equivalent insurance policies at no less than the limits shown below and cause its subcontractors to maintain similar insurance with limits acceptable to LFUCG in order to protect LFUCG against claims for injuries to persons or damages to property which may arise from or in connection with the performance of the work hereunder by CONTRACTOR. The cost of such insurance shall be included in any bid:

<u>Coverage</u>	<u>Limits</u>
General Liability (Insurance Services Office Form CG 00 01)	\$1 million per occurrence, \$2 million aggregate or \$2 million combined single limit
Commercial Automobile Liability (Insurance Services Office Form CA 0001)	\$1 million per occurrence
Worker's Compensation	Statutory
Employer's Liability	\$100,000.00
Excess/Umbrella Liability	\$1 million per occurrence

The policies above shall contain the following conditions:

- a. All Certificates of Insurance forms used by the insurance carrier shall be properly filed and approved by the Department of Insurance for the Commonwealth of Kentucky (DOI). LFUCG shall be named as an additional insured in the General Liability Policy and Commercial Automobile Liability Policy using the Kentucky DOI approved forms.
- b. The General Liability Policy shall be primary to any insurance or self-insurance retained by LFUCG.

- c. The General Liability Policy shall include a Products and Completed Operations endorsement or Premises and Operations Liability endorsement unless it is deemed not to apply by LFUCG.
- d. LFUCG shall be provided at least 30 days advance written notice via certified mail, return receipt requested, in the event any of the required policies are canceled or non-renewed.
- e. Said coverage shall be written by insurers acceptable to LFUCG and shall be in a form acceptable to LFUCG. Insurance placed with insurers with a rating classification of no less than Excellent (A or A-) and a financial size category of no less than VIII, as defined by the most current Best's Key Rating Guide shall be deemed automatically acceptable.

Renewals

After insurance has been approved by LFUCG, evidence of renewal of an expiring policy must be submitted to LFUCG, and may be submitted on a manually signed renewal endorsement form. If the policy or carrier has changed, however, new evidence of coverage must be submitted in accordance with these Insurance Requirements.

Deductibles and Self-Insured Programs

IF YOU INTEND TO SUBMIT A SELF-INSURANCE PLAN IT MUST BE FORWARDED TO LEXINGTON-FAYETTE URBAN COUNTY GOVERNMENT, DIVISION OF RISK MANAGEMENT, 200 EAST MAIN STREET, LEXINGTON, KENTUCKY 40507 NO LATER THAN A MINIMUM OF FIVE (5) WORKING DAYS PRIOR TO THE RESPONSE DATE. Self-insurance programs, deductibles, and self-insured retentions in insurance policies are subject to separate approval by Lexington-Fayette Urban County Government's Division of Risk Management, upon review of evidence of BIDDER/CONTRACTOR's financial capacity to respond to claims. Any such programs or retentions must provide LFUCG with at least the same protection from liability and defense of suits as would be afforded by first-dollar insurance coverage. If BIDDER/CONTRACTOR satisfies any portion of the insurance requirements through deductibles, self-insurance programs, or self-insured retentions, BIDDER/CONTRACTOR agrees to provide Lexington-Fayette Urban County Government, Division of Risk Management, the following data prior to the final acceptance of bid and the commencement of any work:

- a. Latest audited financial statement, including auditor's notes.
- b. Any records of any self-insured trust fund plan or policy and related accounting statements.
- c. Actuarial funding reports or retained losses.

- d. Risk Management Manual or a description of the self-insurance and risk management program.
- e. A claim loss run summary for the previous five (5) years.
- f. Self-Insured Associations will be considered.

Safety and Loss Control

CONTRACTOR shall comply with all applicable federal, state, and local safety standards related to the performance of its works or services under this Agreement and take necessary action to protect the life, health and safety and property of all of its personnel on the job site, the public, and LFUCG.

Verification of Coverage

BIDDER/CONTRACTOR agrees to furnish LFUCG with all applicable Certificates of Insurance signed by a person authorized by the insurer to bind coverage on its behalf prior to final award, and if requested, shall provide LFUCG copies of all insurance policies, including all endorsements.

Right to Review, Audit and Inspect

CONTRACTOR understands and agrees that LFUCG may review, audit and inspect any and all of its records and operations to insure compliance with these Insurance Requirements.

DEFAULT

BIDDER/CONTRACTOR understands and agrees that the failure to comply with any of these insurance, safety, or loss control provisions shall constitute default and that LFUCG may elect at its option any single remedy or penalty or any combination of remedies and penalties, as available, including but not limited to purchasing insurance and charging BIDDER/CONTRACTOR for any such insurance premiums purchased, or suspending or terminating the work.

00357187

3. WAGE SCALES – NOT APPLICABLE.

4. WEATHER RELATED DELAYS

- A. The Project Completion date shall be established with the understanding that no extension of time will be granted for weather related delays that are within the average temperature or number of rain or snow days within a particular month. The average weather conditions shall be established by referencing the records of the National Oceanic and Atmospheric Administration (NOAA) and as defined herein.
- B. Extensions of inclement weather shall be granted only when the work affected must be on schedule at the time of delay. No time will be granted for work which is behind schedule in excess of the actual delay caused by the weather, assuming the work had been on schedule.
- C. Time granted for weather delays shall be requested on a monthly basis.
- D. The weather experienced at the project site during the contract period must be found to be unusually severe, that is more severe than the adverse weather anticipated for the project location during any given month. The unusually severe weather must actually cause a delay to the completion of the project. The delay must be beyond the control and without the fault or negligence of the contractor.
- E. The anticipated adverse weather delays shall be based on the National Oceanic and Atmospheric Administration (NOAA) climatology ten year average for the Lexington Bluegrass Airport KY US location. The Mean Number of Days of daily precipitation using ≥ 0.10 will determine the base line for monthly anticipated adverse weather evaluations. The contractor's progress schedule must reflect these anticipated adverse weather delays in all weather dependent activities. Upon acknowledgement of the Notice to Proceed (NTP) and continuing throughout the contract, the contractor will record the occurrence of actual adverse weather and resultant impact to normally scheduled work. Actual adverse weather delay days must prevent work on critical path activities for 50 percent or more of the contractor's scheduled work date. The number of actual adverse weather delay days shall be calculated chronologically from the first to the last day of each month, and be recorded as full days. The number of actual adverse weather days greater than the number of anticipated adverse weather days, listed above, shall be the number of unusually severe weather days for the purposes of any contract extensions (actual adverse weather days - anticipated adverse weather days = unusually severe weather days.)
- F. Definitions:
1. "Unusually severe weather" - weather that is more severe than the adverse weather anticipated for the season or location involved.

2. "Adverse weather" - atmospheric conditions at a definite time and place that are unfavorable to construction activities.

PART VI
CONTRACT AGREEMENT

INDEX

1.	SCOPE OF WORK.....	CA-2
2.	TIME OF COMPLETION.....	CA-2
3.	ISSUANCE OF WORK ORDERS	CA-2
4.	THE CONTRACT SUM	CA-2
5.	PROGRESS PAYMENTS	CA-3
6.	ACCEPTANCE AND FINAL PAYMENT.....	CA-3
7.	THE CONTRACT DOCUMENTS.....	CA-3
8.	EXTRA WORK.....	CA-3
9.	SPECIFICATIONS AND DRAWINGS.....	CA-4

PART VI

CONTRACT AGREEMENT

THIS AGREEMENT, made on the 16th day of April, 2026, by and between **Lexington-Fayette Urban County Government**, acting herein called "OWNER" and **Davis H. Elliott Construction Company, Inc.**, doing business as *(an individual) (a partnership) (a corporation) located in the City of Lexington, County of Fayette, and State of Kentucky, hereinafter called "CONTRACTOR."

WITNESSETH: That the CONTRACTOR and the OWNER in consideration of **One Hundred Twenty-seven Thousand Three Hundred Seventy-five** Dollars and **Zero** Cents (**\$127,375.00**) quoted in the proposal by the CONTRACTOR, dated April 7, 2026, hereby agree to commence and complete the construction described as follows:

1. SCOPE OF WORK

The CONTRACTOR shall furnish all the materials, supplies, machinery, equipment, tools, superintendence, labor, insurance, and other accessories and services necessary to complete the said project in accordance with the conditions and prices stated in the Proposal, the General Conditions, and the Special Conditions of the Contract, the Specifications and Contract Documents therefore as prepared by LFUCG for the Concrete Tee Pads and Sign Posts for Disc Golf Course.

2. TIME OF COMPLETION

The time estimated and authorized by the OWNER for the proper execution of the Work by the Contract, in full, is hereby fixed as forty-five (45) days to final completion. The time shall begin in accordance with the Notice to Proceed provided by OWNER.

3. ISSUANCE OF WORK ORDERS

Notice to begin Work will be given in whole or for part of the Work as determined by the OWNER pending the availability of funds. The order of construction will be as determined after consultation between the CONTRACTOR and the OWNER.

4. THE CONTRACT SUM

The OWNER agrees to pay the CONTRACTOR in current funds for the performance of the Contract, as quoted in the proposal, subject to any additions and deductions, as provided therein.

5. PROGRESS PAYMENTS

The OWNER shall make payments on account of the Contract, as provided in accordance with the General Conditions, less the aggregate of previous payments.

6. ACCEPTANCE AND FINAL PAYMENT

Final payment shall be due within ninety (90) days after completion of the Work, provided the Work be then fully completed and the Contract fully accepted.

Before issuance of final certificate, the CONTRACTOR shall submit evidence satisfactory to the Owner that all payrolls, material bills, and other indebtedness connected with the Work has been paid.

If, after the Work has been substantially completed, full completion thereof is materially delayed through no fault of the CONTRACTOR, the OWNER shall without terminating the Contract, make payment of the balance due for that portion of the Work fully completed and accepted. Such payment shall be made under the terms and conditions governing final payment, except that it shall not constitute a waiver of claims.

7. THE CONTRACT DOCUMENTS

The Advertisement for Bids, Information for Bidders, the General Conditions, Performance and Payment Bonds, Contract Agreement, Special Conditions, Technical Specifications, any and all Addenda, and Proposal, Ion Wave Q&A, and Plan Drawings form the Contract, and they are fully a part of the Contract as if hereto attached or herein repeated.

8. EXTRA WORK

The OWNER, without invalidating the Contract, may order extra work or make changes by altering, adding to or deducting from the Work, the Contract Sum being adjusted accordingly. All such Work shall be executed and paid for in accordance with the General Conditions, which is a part of this Contract.

9. **THE FOLLOWING IS AN ENUMERATION OF THE SPECIFICATIONS AND DRAWINGS (CONTRACT DOCUMENTS):**

SPECIFICATIONS

**SECTION
NO.**

TITLE

I	Advertisement for Bids
II	Information for Bidders
III	Form of Proposal
IV	General Conditions
V	Special Conditions
VI	Contract Agreement
VII	Performance and Payment Bonds
VIII	Addenda
IX	Technical Specifications and Drawings

IN WITNESSETH WHEREOF, the parties hereto have executed this Contract as of the date and year above written.

(Seal)

Lexington-Fayette Urban County Government.
Lexington, Kentucky

(Owner)

ATTEST:

[Signature]
Clerk of the Urban County Council

BY: [Signature: Linda Gorton]
MAYOR

[Signature: Mackenzie Jack]
(Witness)

[Signature: Mayor]
(Title)

(Contractor)



[Signature: Stephanie Allen]
Asst. (Secretary)* Stephanie Allen

BY: [Signature: Julia E. Bellendir]
Julia E. Bellendir

[Signature: Shelly Amott]
(Witness)

[Signature: Vice President]
(Title)

673 Blue Sky Parkway, Lexington, KY 40509
(Address and Zip Code)

IMPORTANT: *Strike out any non-applicable terms.

Secretary of the Owner should attest. If the CONTRACTOR is corporation, Secretary should attest. Give proper title of each person-executing Contract.

PART VII

PERFORMANCE AND PAYMENT BONDS

1. PERFORMANCE BOND
2. PAYMENT BOND

PART VII

Bond No. 14BCSJM2663

PERFORMANCE BOND

KNOW ALL MEN BY THESE PRESENTS, that

Davis H. Elliot Construction Company, Inc.

(Name of CONTRACTOR)

673 Blue Sky Parkway, Lexington, KY 40509

(Address of CONTRACTOR)

a Corporation, hereinafter

(Corporation, Partnership, or Individual)

called Principal, and Hartford Fire Insurance Company

(Name of Surety)

One Hartford Plaza, Hartford, CT 06155-0001

(Address of Surety)

hereinafter called Surety, are held and firmly bound unto

LEXINGTON-FAYETTE URBAN COUNTY GOVERNMENT

200 East Main Street, Third Floor

Lexington, Kentucky 40507

hereinafter called "OWNER" in the penal sum of: One Hundred Twenty-seven Thousand Three Hundred Seventy Five Dollars, (\$ 127,375.00), for the payment of whereof Principal and Surety bind themselves, their heirs, executors, administrators, successors, and assigns, jointly and severally, firmly by these presents.

WHEREAS, Principal by written agreement is entering into a Contract with OWNER for Concrete Tee Pads and Sign Post for Disc Golf Course in accordance with drawings and specifications prepared by: LFUCG Parks and Recreation which Contract is by reference made a part hereof, and is hereinafter referred to as the Contract.

NOW THEREFORE, THE CONDITION OF THIS OBLIGATION is such that if the Principal shall promptly and faithfully perform said Contract, then this obligation shall be null and void; otherwise it shall remain in full force and effect.

The Surety hereby waives notice of any alteration or extension of time made by the OWNER.

Whenever, Principal shall be, and declared by OWNER to be in default under the Contract, the OWNER having performed OWNER'S obligations thereunder, the Surety may promptly remedy the default, or shall promptly:

- (1) Complete the Contract in accordance with its terms and conditions or
- (2) Obtain a bid or bids for completing the Contract in accordance with its terms and conditions, and upon determination by Surety of the lowest responsible bidder, or if the OWNER elects, upon determination by the OWNER and Surety jointly of the lowest responsible bidder, arrange for a Contract between such bidder and OWNER, and make available as Work progresses (even though there may be a default or a succession of defaults under the Contract or Contracts of completion arranged under this paragraph) sufficient funds to pay the cost of completion less the balance of the Contract Price; but not exceeding, including other costs and damages for which the Surety may be liable hereunder, the amount set forth in the first paragraph hereof. The term "balance of the Contract Price", as used in this paragraph shall mean the total amount payable by OWNER to Principal under the Contract and any amendments thereto, less the amount properly paid by OWNER to Principal.

Any suit under this bond must be instituted before the expiration of two (2) years from the date on which final payment under the Contract falls due.

No right of action shall accrue on this bond to or for the use of any person or corporation other than the OWNER named herein or the heirs, executors, administrators or successors of OWNER.

IN WITNESS WHEREOF, this instrument is executed in 3 each one of which shall be
(number)
deemed an original, this the 30th day of April, 2026.

ATTEST:

Davis H. Elliot Construction Company, Inc.
Principal

Stephanie Lee Allen
(Principal) Secretary, Stephanie Lee Allen
Asst.

BY: *Julia E. Bellendir* (s)
Julia E. Bellendir, Vice President
673 Blue Sky Parkway
(Address)
Lexington, KY 40509

Shelley Amett
Witness as to Principal

673 Blue Sky Parkway
(Address)
Lexington, KY 40509

Hartford Fire Insurance Company
Surety

BY: *John*
Attorney-in-Fact
One Hartford Plaza
(Address)
Hartford, CT 06155-0001

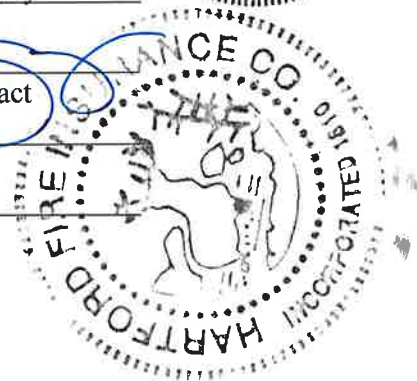

ATTEST:

Susan Finocchio
(Surety) Secretary Susan Finocchio,
Office Coordinator

(SEAL)
Beverly Jones, III
Witness as to Surety Beverly Jones, III
701 Cool Springs Blvd, Suite 200
(Address)
Franklin, TN 37067

TITLE: Attorney-in-Fact
Surety

BY: Suzanne Helena Young

TITLE: Bond Producer

NOTE: The number of executed counterparts of the bond shall coincide with the number of executed counterparts of the Contract.

PART VII

Bond No. 14BCSJM2663

PAYMENT BOND

KNOW ALL MEN BY THESE PRESENT: that

Davis H. Elliot Construction Company, Inc.

(Name of Contractor)

673 Blue Sky Parkway Lexington, KY 4050

(Address of Contractor)

a Corporation, hereinafter

(Corporation, Partnership or Individual)

called Principal, and Hartford Fire Insurance Company

(Name of Surety)

One Hartford Plaza, Hartford, CT 06155-0001

(Address of Surety)

hereinafter called Surety, are held and firmly bound unto:

LEXINGTON-FAYETTE URBAN COUNTY GOVERNMENT
200 East Main Street, Third Floor
Lexington, Kentucky 40507

Obligee, hereinafter called OWNER, for the use and benefit of claimants as hereinafter defined, in the amount of One Hundred Twenty-seven Thousand Three Hundred Seventy Five Dollars (\$ 127,375.00) the payment whereof Principal and Surety bind themselves, their heirs, executors, administrators, successors, and assigns, jointly and severally, firmly by these presents.

WHEREAS, Principal by written agreement is entering into a Contract with OWNER for Concrete Tee Pads and Sign Post for Disc Golf Course in accordance with drawings and specifications prepared by: LFUCG Parks and Recreation which Contract is by reference made a part hereof, and is hereinafter referred to as the Contract.

NOW, THEREFORE, THE CONDITION OF THIS OBLIGATION is such that, if Principal shall promptly make payment to all claimants as hereinafter defined for all labor and material used or reasonably required for use in the performance of the Contract, then this obligation shall be void; otherwise it shall remain in full force and effect, subject, however, to the following conditions.

1. A claimant is defined as one having a direct contract with the Principal or with a Subcontractor of the Principal for labor, material, or both, used or reasonably required for use in the performance of the Contract, labor and material being construed to include that part of water, gas, power, light, heat, oil, gasoline, telephone service or rental of equipment directly applicable to the Contract.

2. The above named Principal and Surety hereby jointly and severally agree with the OWNER that every claimant as herein defined, who has not been paid in full before the expiration of a period of ninety (90) days after the date on which the last of such claimant's work or labor was done or performed, or materials were furnished by such claimant, may sue on this bond for the use of such claimant, prosecute the suit to final judgment for such sum or sums as may be justly due claimant, and have execution thereon. The OWNER shall not be liable for the payment of any costs or expenses of any such suit.

3. No suit or action shall be commenced hereunder by any claimant:
 - (a) Unless claimant, other than one having a direct contract with the Principal, shall have given written notice to any two of the following: The Principal, the OWNER, or the Surety above named, within ninety (90) days after such claimant did or performed the last of the Work or labor, or furnished the last of the materials for which said claim is made, stating with substantial accuracy the amount claimed and the name of the party to whom the materials were furnished, or for whom the Work or labor was done or performed. Such notice shall be served by mailing the same by registered mail or certified mail, postage prepaid, in an envelope addressed to the Principal, OWNER, or Surety, at any place where an office is regularly maintained for the transaction of business, or served in any manner in which legal process may be served in the state in which the aforesaid project is located, save that such service need not be made by a public officer.
 - (b) After the expiration of one (1) year following the date on which Principal ceased Work on said Contract, it being understood, however, that if any limitation embodied in this bond is prohibited by any law controlling the construction hereof such limitation shall be deemed to be amended so as to be equal to the minimum period of limitation permitted by such law.
 - (c) Other than in a state court of competent jurisdiction in and for the county or other political subdivision of the state in which the project, or any part thereof, is situated, or in the United States District Court for the district in which the project, or any part thereof, is situated, and not elsewhere.

4. The amount of this bond shall be reduced by and to the extent of any payment or payments made in good faith hereunder, inclusive of the payment by Surety of mechanics' liens which may be filed of record against aid improvement, whether or not claim for the amount of such lien be presented under and against this bond.

IN WITNESS WHEREOF, this instrument is executed in 3 counterparts, each one of (number)

which shall be deemed an original, this the 30th day of April, 2026.

ATTEST:

Davis H. Elliot Construction Company, Inc.
(Principal)

Stephanie Lee Allen
(Principal) Secretary, *Stephanie Lee Allen*
ASST

(SEAL)

BY: *Julia E. Calender* (s)
Julia E. Calender, Vice President
673 Blue Sky Parkway
(Address)
Lexington, KY 40509



Shelley Arnett
(Witness to Principal)

673 Blue Sky Parkway
(Address)
Lexington, KY 40509

Hartford Fire Insurance Company
(Surety)

ATTEST:

Susan Finocchio
(Surety) ~~Secretary~~ Susan Finocchio,
Office Coordinator

BY: *Suzanne Helena Young*
Suzanne Helena Young, (Attorney-in-Fact)



(SEAL)
Beverly Jones
Witness as to Surety Beverly Jones, III
701 Cool Springs Blvd., Suite 200
(Address)
Franklin, TN 37067

One Hartford Plaza
(Address)
Hartford, CT 06155-0001

NOTE: The number of executed counterparts of the bond shall coincide with the number of executed counterparts of the Contract.

END OF SECTION

POWER OF ATTORNEY

Direct Inquiries, Bond Authenticity
and Claims to:
THE HARTFORD
BOND, T-14
One Hartford Plaza
Hartford, Connecticut 06155
Bond.Claims@thehartford.com
call: 888-266-3488 or fax: 860-757-5835

KNOW ALL PERSONS BY THESE PRESENTS THAT:

Agency Name: James A Scott & Son Inc
Agency Code: 14-730214 (MC), 14-730836, 14-731912, 22-273001

- Hartford Fire Insurance Company**, a corporation duly organized under the laws of the State of Connecticut
- Hartford Casualty Insurance Company**, a corporation duly organized under the laws of the State of Indiana
- Hartford Accident and Indemnity Company**, a corporation duly organized under the laws of the State of Connecticut
- Hartford Insurance Company of the Midwest**, a corporation duly organized under the laws of the State of Indiana

having their home office in Hartford, Connecticut, (hereinafter collectively referred to as the "Companies") do hereby make, constitute and appoint, up to the amount of Unlimited:

Clayton T Bruin, Benton Davis Lietz, Charles Auer Seinsheimer of **Charlotte NC**; Stacey W. Hall, James Jackson Roberts, III, Steven Dana Scobey of **Richmond VA**; Robert M Coon, Benjamin Kenneth Taylor of **Greensboro NC**; Windy D Lovelady, Brooke Gagne of **Raleigh NC**; Bethany Murphy, Traci J DeGroat of **Roanoke VA**; Beverly Jones, III, Suzanne Helena Young, Elba Irene McCullough, Allison Kate Burgdorf of **Franklin TN**; Stephen B. Dolin, Joanna M. Carson, Melissa V. Carver, Alaine Nanette Drane of **Lynchburg VA**

their true and lawful Attorney(s)-in-Fact, each in their separate capacity if more than one is named above, to sign its name as surety(ies) only as delineated above by , and to execute, seal and acknowledge any and all bonds, undertakings, contracts and other written instruments in the nature thereof, on behalf of the Companies in their business of guaranteeing the fidelity of persons, guaranteeing the performance of contracts and executing or guaranteeing bonds and undertakings required or permitted in any actions or proceedings allowed by law.

In Witness Whereof, and as authorized by a Resolution of the Board of Directors of the Companies on May 23, 2016 the Companies have caused these presents to be signed by its Assistant Vice President and its corporate seals to be hereto affixed, duly attested by its Assistant Secretary. Further, pursuant to Resolution of the Board of Directors of the Companies, the Companies hereby unambiguously affirm that they are and will be bound by any mechanically applied signatures applied to this Power of Attorney.



Phyllis A. Clark

Phyllis A. Clark, Assistant Secretary

Joelle L. LaPierre

Joelle L. LaPierre, Assistant Vice President

STATE OF FLORIDA

COUNTY OF SEMINOLE

ss. Lake Mary

On this 1st day of March, 2024, before me personally came Joelle L. LaPierre, to me known, who being by me duly sworn, did depose and say: that (s)he resides in Seminole County, State of Florida that (s)he is the Assistant Vice President of the Companies, the corporations described in and which executed the above instrument; that (s)he knows the seals of the said corporations; that the seals affixed to the said instrument are such corporate seals; that they were so affixed by authority of the Boards of Directors of said corporations and that (s)he signed his/her name thereto by like authority.



Mariluz Arce

Mariluz Arce
My Commission HH 287363
Expires July 13, 2026

I, the undersigned, Assistant Vice President of the Companies, DO HEREBY CERTIFY that the above and foregoing is a true and correct copy of the Power of Attorney executed by said Companies, which is still in full force effective as of April 30, 2026.

Signed and sealed in Lake Mary, Florida.



Keith D. Dozois

Keith D. Dozois, Assistant Vice President

PART VIII

ADDENDA

All addenda issued during the bidding of the Project will be reproduced in the signed Contract Documents, on the pages following this heading sheet.

<u>Addendum Number</u>	<u>Title</u>	<u>Date</u>
1.	_____	_____
2.	_____	_____
3.	_____	_____
4.	_____	_____
5.	_____	_____

IX. TECHNICAL SPECIFICATIONS

Request for Bids for Construction of Disc Golf Course Features

The Lexington-Fayette Urban County Government (LFUCG) Division of Parks and Recreation is building a new disc golf course at Coldstream Park. The course has been designed by Houck Design as an 18-hole course and will include at least one tee pad and two baskets per hole. It has already been laid out per graphic below. This bid involves purchase and/or installation of the following key elements:

1. Disc golf concrete tee pads
2. Sign posts
3. Disc golf baskets

Contractor will provide line-item pricing for each of the three elements.

Site Access and Logistics

Primary construction access to the site will be at the end of Sandersville Road, between 1808 and 1816 Arbor Station Way. The construction entrance has already been established for a different scope of work and should be capable of supporting construction vehicle traffic. Contractor will maintain a safe and clean site. Contractor can utilize the area noted below with dashed circle for on site storage of construction equipment but all equipment and vehicles must be secured if left on site. Contractor responsible for any damage to park or equipment due to improper storage.



Figure 2. Primary site construction access.

The overall site is a combination of rolling hills and low-land areas. Much of the site may be challenging for a typical concrete truck to traverse, and there will not be construction road surface through the site to facilitate concrete trucks. An intermittent stream bisects the site, but there is one potential crossing point for lighter weight construction equipment that currently has #2 stone for structural support (shown in Figure 3). Another possible access point is from Bull Lea Lane, adjacent to Eastern State Hospital, but there is a steep hill there that represents a challenge. Contractor will be responsible for formulating plan to move stone and concrete to disparate locations on site for tee pad, sign post, and basket installations. Owner expects use of buggies or other lower capacity options to complete project scope.



Figure 3. Additional site access considerations.

Specifications

Tee Pad Installation Requirements

1. The tee pads must be formed and finished broom swept concrete, set on a 3" thick base of compacted #57s. The dimensions for each tee pad will be as noted in Figure 4. Each pad will have a single control joint at each pad midpoint. Control joints to be floated and filled with polyurethane self-leveling sealant. Tee pads to have max longitudinal and cross slope of ¼ inch per foot.
2. There will be a total of 28 tee pads, per Figure 4. In general, the different sizes specified are:
 - a. (10) 6 feet wide by 13 feet length by 4.5" thick
 - b. (18) 5 feet wide by 12 feet length by 4.5" thick
3. Most of the tee pads will be located on relatively flat ground, but there will be several that may be located partially on sloped terrain and will require some localized grading extending out 5-15 feet in any direction to create a level surface. All tee pads should have a level and flush surface extending 5 ft out on all sides, unless otherwise approved by the Owner.
4. The cut and fill should be balanced on site.
5. All disturbed land shall be seeded and strawed.
6. For all concrete tee pads the concrete must be transported to each individual location using either buggies, a mini mixer on a trailer, or Contractor may propose alternative.

Hole Number	Number of Tee Pad(s)	Size of Tee Pad(s)	Location GPS (Decimal Degrees)
1	2	6'x13' 5'x12'	38.0936N 84.499907W 38.093126N 84.499898W
2	2	6'x13' 5'x12'	38.090165N 84.501341W 38.089828N 84.501085W
3	1	5'x12'	38.088017N 84.500412W
4	2	6'x13' 5'x12'	38.086877N 84.499174W 38.086697N 84.498635W
5	2	6'x13' 5'x12'	38.085295N 84.497299W 38.085406N 84.497578W
6	2	6'x13' 5'x12'	38.085939N 84.499292W 38.085505N 84.499779W
7	1	5'x12'	38.083511N 84.499837W
8	2	6'x13' 5'x12'	38.083042N 84.500812W 38.083417N 84.50057W
9	2	6'x13' 5'x12'	38.084536N 84.50086W 38.084809N 84.501013W
10	1	5'x12'	38.085236N 84.502165W
11	1	5'x12'	38.086272N 84.502943W
12	1	5'x12'	38.085659N 84.501423W
13	2	6'x13'	38.085111N 84.500626W

		5'x12'	38.08527N 84.500345W
14	1	5'x12'	38.086611N 84.499938W
15	1	5'x12'	38.086161N 84.500227W
16	2	6'x13' 5'x12'	38.085758N 84.501012W 38.085979N 84.500603W
17	2	6'x13' 5'x12'	38.087862N 84.500657W 38.088259N 84.500677W
18	1	5'x12'	38.089251N 84.502689W

Figure 4. Table of disc golf tee pads and approximate locations

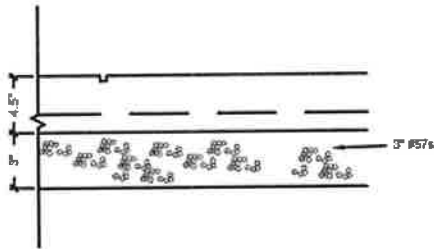

NOTES:

- * ADD 4" OF #2/#3s UNDER DGA WHERE SPECIFIED.
- * ADD 1/4" DEEP FLOATED CONTROL JOINTS AS INDICATED BY PAD DIMENSIONS DRAWING
- * BROOM FINISH, 1/4" PER FOOT SLOPE
- * 3500 PSI CONC. @28 DAYS; 6x6x1.4x1.4 WWF 1 1/2" MIN. CLEAR

Figure 5. Concrete pavement detail.

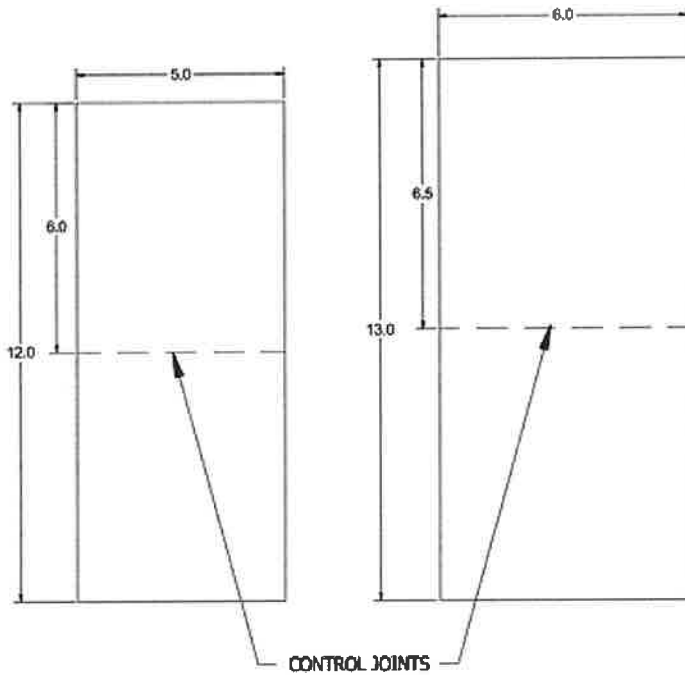

Figure 6. Tee pad dimensions detail

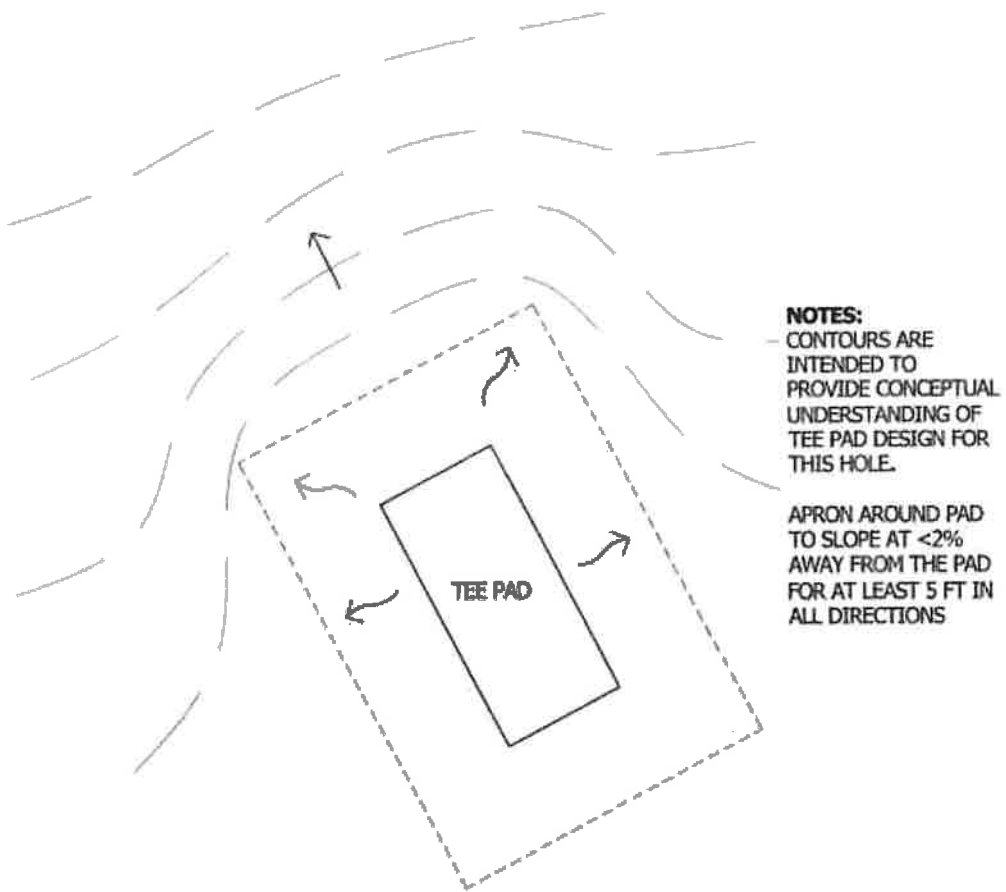

Figure 7. Tee pad grading concept for Hole 8 and 10. Pad to be 6'x13'

Tee Pad Sign Post Installation

Near/behind each tee pad, owner/designer will determine location for a timber sign post. The post should be ground contact treated 4"x4". Post to be 4 ft tall above ground, with angle cut tops. Post should be anchored to Simpson Strong Tie. Set in concrete footer with minimum depth of 18" and post hole diameter of 12". Post should be set with taller face parallel to tee pad. After post is set, wood to be stained to match 3-board fencing. There will be a total of 28 tee-pad sign posts. Sign panels to be designed, fabricated, and installed by others. All land disturbed by footer installation to be cleanly distributed and seeding and strawing.

SIGN PANEL TO BE ATTACHED CENTERED AND FLUSH WITH TOP OF POST.

POST TO BE ATTACHED TO SIMPSON STRONG-TIE MODEL #APVB44.

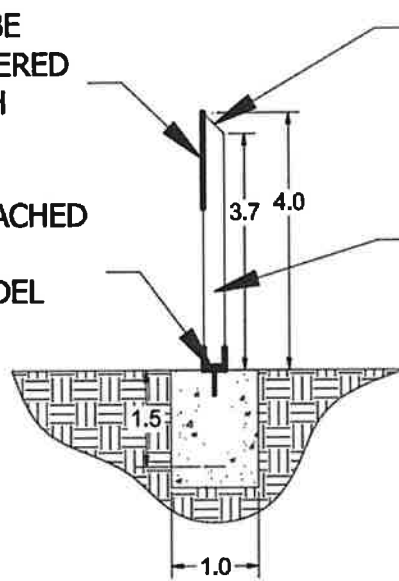

TOP OF POST TO BE ANGLE CUT TO FACILITATE DRAINAGE AND PREVENT ROT.

POST TO BE 4"X4" GROUND CONTACT TREATED. POST TO BE STAINED WITH WOOD DEFENDER (COFFEE BROWN).

Figure 8. Tee pad sign post detail

Disc Golf Basket Type and Installation

The disc golf baskets are to be MVP Disc Sports Black Hole Gravity. There will be **18 red powder-coated** baskets, **18 blue powder-coated** baskets, and then **2 black powder-coated**. Baskets will be a permanent installation and follow manufacturer's instructions below, and here:

mvpdiscsports.com/downloads/Portal_Installation_Instructions.pdf.

BLACK HOLE[®] PORTAL



Installation Instructions



MVP makes installing your basket a breeze with our permanent installation kit.

To secure your MVP Black Hole Portal basket to the ground you need to install a permanent sleeve for each basket location, then adding the baskets themselves is as easy as sliding the basket's pole into each sleeve and locking them into place.

Follow these steps and pay careful attention to detail to make sure your baskets end up perfectly level and at the correct height.

- 1** Carefully choose your location of the permanent sleeve, considering the flight lines from the tee and fairway, and the surrounding trees and bushes.
- 2** At your chosen location, use a shovel or a post hole digger to dig a hole 8-10 inches wide, and 2 feet deep.
- 3** Add a layer of river rocks or gravel to the bottom of the hole for drainage.
- 4** Put the sleeve into the hole until just the top of the sleeve locking collar is above the ground.
- 5** After testing the depth of the sleeve, fill the area surrounding the sleeve $\frac{3}{4}$ of the way full with quick drying concrete.
- 6** Using a level, test the sleeve and make adjustments to ensure that the top of the sleeve is level. This is an important step because being slightly off level at this stage will be magnified by a leaning basket later.
- 7** Hold in place once level and fill in rest of concrete. Double check level, adjust if needed.
- 8** Let the concrete dry following the concrete mix instructions, we recommend at least a few days due to the weight of the basket and depth of the concrete.
- 9** When the concrete has set and your sleeve is firmly installed, insert the basket into the sleeve and lock securely with a padlock.

CONCRETE TEE PADS AND SIGN POSTS FOR DISC GOLF COURSE

SECTION 311000 – SITE CLEARING

PART 1 - GENERAL

1.1 RELATED DOCUMENTS

- A. Drawings and general provisions of the Contract, including General and Supplementary Conditions and Division 01 Specification Sections, apply to this Section.

1.2 SUMMARY

- A. This Section includes the following:
 - 1. Protecting existing trees and grass to remain.
 - 2. Removing existing trees, shrubs, groundcovers plants and grass.
 - 3. Clearing and grubbing.
 - 4. Stripping and stockpiling topsoil.
 - 5. Removing above- and below-grade site improvements.
 - 6. Disconnecting, capping or sealing and removal of storm drainage utilities.
 - 7. Temporary erosion and sedimentation control measures.
- B. Related Sections include the following:
 - 1. Division 01 Section "Temporary Facilities and Controls" for temporary utilities, temporary construction and support facilities, temporary security and protection facilities.
 - 2. Division 01 Section "Temporary Tree and Plant Protection" for protecting trees remaining on-site that are affected by site operations.
 - 3. Division 01 Section "Execution" for verifying utility locations and for recording field measurements.
 - 4. Division 31 Section "Earth Moving" for soil materials, excavating, backfilling, and site grading.
 - 5. Division 23 Section "Turf and Grasses and Plants" for finish grading including preparing and placing planting soil mixes and testing of topsoil material.
 - 6. Division 21, Division 22, Division 23, Division 26, Division 27, and Division 28 Sections for removal of site utilities except storm sewers.

1.3 DEFINITIONS

- A. Topsoil: Natural or cultivated surface-soil layer containing organic matter and sand, silt, and clay particles; friable, pervious, and black or a darker shade of brown, gray, or red than underlying subsoil; reasonably free of subsoil, clay lumps, gravel, and other objects more than 2 inches in diameter; and free of subsoil and weeds, roots, toxic materials, or other nonsoil materials.
- B. Tree Protection Zone: Area surrounding individual trees or groups of trees to be protected during construction, and defined by the drip line of individual trees or the perimeter drip line of groups of trees, unless otherwise indicated.

CONCRETE TEE PADS AND SIGN POSTS FOR DISC GOLF COURSE

1.4 MATERIAL OWNERSHIP

- A. Except for stripped topsoil or other materials indicated to remain Owner's property, cleared materials shall become Contractor's property and shall be removed from Project site.

1.5 SUBMITTALS

- A. Photographs or videotape, sufficiently detailed, of existing conditions of trees and plantings, adjoining construction, and site improvements that might be misconstrued as damage caused by site clearing.
- B. Record drawings, according to Division 01 Section "Project Record Documents," identifying and accurately locating capped utilities and other subsurface structural, electrical, and mechanical conditions.
- C. Storm Water Pollution Prevention Plan: Submit prior to beginning construction and maintain on-site, and available for regular review by the Architect the following:
 - 1. Copy of the Notice of Intent (NOI) if applicable.
 - 2. Copy of the Site Grading Permit if applicable.
 - 3. Copy of the SWPPP along with related written documents.
 - 4. Maintenance Log Book in conformance with the requirements indicated.

1.6 QUALITY ASSURANCE

- A. Preinstallation Conference: Conduct conference at Project site to comply with requirements in Division 01 Section "Project Management and Coordination."

1.7 PROJECT CONDITIONS

- A. Traffic: Minimize interference with adjoining roads, streets, walks, and other adjacent occupied or used facilities during site-clearing operations.
 - 1. Do not close or obstruct streets, walks, or other adjacent occupied or used facilities without permission from Owner and authorities having jurisdiction.
 - 2. Provide alternate routes around closed or obstructed traffic ways if required by authorities having jurisdiction.
- B. Improvements on Adjoining Property: Authority for performing site clearing indicated on property adjoining Owner's property will be obtained by Owner before award of Contract.
 - 1. Do not proceed with work on adjoining property until directed by Architect.
- C. Salvable Improvements: Carefully remove items indicated to be salvaged and store on Owner's premises where indicated.
- D. Utility Locator Service: Notify utility locator service for area where Project is located before site clearing.
- E. Do not commence site clearing operations until temporary erosion and sedimentation control measures are in place.

CONCRETE TEE PADS AND SIGN POSTS FOR DISC GOLF COURSE

PART 2 - PRODUCTS

2.1 SOIL MATERIALS

- A. Satisfactory Soil Materials: Requirements for satisfactory soil materials are specified in Division 31 Section "Earth Moving."
 - 1. Obtain approved borrow soil materials off-site when satisfactory soil materials are not available on-site.

PART 3 - EXECUTION

3.1 PREPARATION

- A. Protect and maintain benchmarks and survey control points from disturbance during construction.
- B. Locate and clearly flag trees and vegetation to remain or to be relocated.
- C. Protect existing site improvements to remain from damage during construction.
 - 1. Restore damaged improvements to their original condition, as acceptable to Owner.

3.2 TEMPORARY EROSION AND SEDIMENTATION CONTROL

- A. Provide temporary erosion and sedimentation control measures to prevent soil erosion and discharge of soil-bearing water runoff or airborne dust to adjacent properties and walkways, according to requirements of authorities having jurisdiction and the Storm Water Pollution Prevention Drawings (SWPP).
- B. Inspect, repair, and maintain erosion and sedimentation control measures during construction until permanent vegetation has been established.
- C. Remove erosion and sedimentation controls and restore and stabilize areas disturbed during removal.

3.3 TREE PROTECTION

- A. Erect and maintain temporary fencing around tree protection zones before starting site clearing. Remove fence when construction is complete.
 - 1. Do not store construction materials, debris, or excavated material within fenced area.
 - 2. Do not permit vehicles, equipment, or foot traffic within fenced area.
 - 3. Maintain fenced area free of weeds and trash.
- B. Do not excavate within tree protection zones, unless otherwise indicated.
- C. Where excavation for new construction is required within tree protection zones, hand clear and excavate to minimize damage to root systems. Use narrow-tine spading forks, comb soil to expose roots, and cleanly cut roots as close to excavation as possible.
 - 1. Cover exposed roots with burlap and water regularly.

CONCRETE TEE PADS AND SIGN POSTS FOR DISC GOLF COURSE

2. Temporarily support and protect roots from damage until they are permanently redirected and covered with soil.
 3. Coat cut faces of roots more than 1-1/2 inches in diameter with an emulsified asphalt or other approved coating formulated for use on damaged plant tissues.
 4. Backfill with soil as soon as possible.
- D. Repair or replace trees and vegetation indicated to remain that are damaged by construction operations, in a manner approved by Architect.
1. Employ an arborist, licensed in jurisdiction where Project is located, to submit details of proposed repairs and to repair damage to trees and shrubs.
 2. Replace trees that cannot be repaired and restored to full-growth status, as determined by Architect.
- 3.4 UTILITIES
- A. Locate, identify, disconnect, and seal or cap off utilities indicated to be removed.
1. Arrange with utility companies to shut off indicated utilities.
- B. Existing Utilities: Do not interrupt utilities serving facilities occupied by Owner or others unless permitted under the following conditions and then only after arranging to provide temporary utility services according to requirements indicated:
1. Notify Architect not less than two days in advance of proposed utility interruptions.
 2. Do not proceed with utility interruptions without Architect's written permission.
- C. Removal of underground utilities is included in Division 21, Division 22, Division 23, Division 26, Division 27, and Division 28 Sections covering site utilities, if applicable.
- 3.5 CLEARING AND GRUBBING
- A. Remove obstructions, trees, shrubs, grass, and other vegetation to permit installation of new construction where required.
1. Do not remove trees, shrubs, and other vegetation indicated to remain or to be relocated.
 2. Cut minor roots and branches of trees indicated to remain in a clean and careful manner where such roots and branches obstruct installation of new construction.
 3. Grind stumps and remove roots, obstructions, and debris extending to a depth of 18 inches below exposed subgrade.
 4. Use only hand methods for grubbing within tree protection zone.
 5. Chip removed tree branches and dispose of off-site.
- B. Fill depressions caused by clearing and grubbing operations with satisfactory soil material unless further excavation or earthwork is indicated.
1. Place fill material in horizontal layers not exceeding a loose depth of 8 inches, and compact each layer to a density equal to adjacent original ground.
- 3.6 TOPSOIL STRIPPING
- A. Remove sod and grass before stripping topsoil.

CONCRETE TEE PADS AND SIGN POSTS FOR DISC GOLF COURSE

- B. Strip topsoil to whatever depths are encountered in a manner to prevent intermingling with underlying subsoil or other waste materials.
 - 1. Remove subsoil and nonsoil materials from topsoil, including trash, debris, weeds, roots, and other waste materials.
- C. Stockpile topsoil materials away from edge of excavations without intermixing with subsoil. Grade and shape stockpiles to drain surface water. Cover to prevent windblown dust.
 - 1. Limit height of topsoil stockpiles to 72 inches.
 - 2. Do not stockpile topsoil within tree protection zones.
 - 3. Dispose of excess topsoil as specified for waste material disposal.
 - 4. Stockpile surplus topsoil to allow for respreading deeper topsoil.

3.7 SITE IMPROVEMENTS

- A. Remove existing above- and below-grade improvements as indicated and as necessary to facilitate new construction. Do not excavate greater than 36" below existing finish grade under any circumstances. Soils below this elevation are hazardous and have been capped previously to protect from exposure.
- B. Remove slabs, paving, curbs, gutters, and aggregate base as indicated.
 - 1. Unless existing full-depth joints coincide with line of demolition, neatly saw-cut length of existing pavement to remain before removing existing pavement. Saw-cut faces vertically.
 - 2. Paint cut ends of steel reinforcement in concrete to remain to prevent corrosion.

3.8 DISPOSAL

- A. Disposal: Remove surplus soil material, unsuitable topsoil, obstructions, demolished materials, and waste materials including trash and debris, and legally dispose of them off Owner's property.

END OF SECTION 311000

CONCRETE TEE PADS AND SIGN POSTS FOR DISC GOLF COURSE

SECTION 321313 – CONCRETE PAVING

PART 1 - GENERAL

1.1 RELATED DOCUMENTS

- A. Drawings and general provisions of the Contract, including General and Supplementary Conditions and Division 01 Specification Sections, apply to this Section.

1.2 SUMMARY

- A. This Section includes exterior cement concrete pavement for the following:
 - 1. Walkways.
 - 2. Curbs
- B. Related Sections include the following:
 - 1. Division 03 Section "Cast-in-Place Concrete" for general building applications of concrete.
 - 2. Division 31 Section "Earth Moving" for subgrade preparation, grading, and subbase course.
 - 3. Division 32 Section "Concrete Paving Joint Sealants" for joint sealants of joints in concrete pavement and at isolation joints of concrete pavement with adjacent construction.

1.3 DEFINITIONS

- A. Cementitious Materials: Portland cement alone or in combination with one or more of blended hydraulic cement, fly ash and other pozzolans, and ground granulated blast-furnace slag.

1.4 SUBMITTALS

- A. Product Data: For each type of manufactured material and product indicated.
- B. Design Mixtures: For each concrete pavement mixture. Include alternate mixture designs when characteristics of materials, Project conditions, weather, test results, or other circumstances warrant adjustments.
- C. Qualification Data: For manufacturer and testing agency.
- D. Material Test Reports: From a qualified testing agency indicating and interpreting test results for compliance of the following with requirements indicated, based on comprehensive testing of current materials:

CONCRETE TEE PADS AND SIGN POSTS FOR DISC GOLF COURSE

- E. Material Certificates: Signed by manufacturers certifying that each of the following materials complies with requirements:
 - 1. Cementitious materials.
 - 2. Steel reinforcement and reinforcement accessories.
 - 3. Admixtures.
 - 4. Curing compounds.
 - 5. Applied finish materials.
 - 6. Bonding agent or epoxy adhesive.
 - 7. Joint fillers.
- F. Field quality-control test reports.
- G. Minutes of preinstallation conference.

1.5 QUALITY ASSURANCE

- A. Manufacturer Qualifications: Manufacturer of ready-mixed concrete products who complies with ASTM C 94/C 94M requirements for production facilities and equipment.
 - 1. Manufacturer certified according to NRMCA's "Certification of Ready Mixed Concrete Production Facilities."
- B. ACI Publications: Comply with ACI 301, "Specification for Structural Concrete," unless modified by requirements in the Contract Documents.
- C. Mockups: Cast mockups of full-size sections of concrete pavement (minimum 4' x 4') to demonstrate typical joints, surface finish, texture, color, and standard of workmanship.
 - 1. Build mockups in the location and of the size indicated or, if not indicated, as directed by Architect.
 - 2. Notify Architect seven days in advance of dates and times when mockups will be constructed.
 - 3. Obtain Architect's approval of mockups before starting construction.
 - 4. Maintain approved mockups during construction in an undisturbed condition as a standard for judging the completed pavement.
 - 5. Demolish and remove approved mockups from the site when directed by Architect.
 - 6. Approved mockups may become part of the completed Work if undisturbed at time of Substantial Completion.
- D. Preinstallation Conference: Conduct conference at Project site to comply with requirements in Division 01 Section "Project Management and Coordination."
 - 1. Before submitting design mixtures, review concrete pavement mixture design and examine procedures for ensuring quality of concrete materials and concrete pavement construction practices. Require representatives, including the following, of each entity directly concerned with concrete pavement, to attend conference:
 - a. Contractor's superintendent.

CONCRETE TEE PADS AND SIGN POSTS FOR DISC GOLF COURSE

- b. Concrete pavement subcontractor.

1.6 PROJECT CONDITIONS

- A. Traffic Control: Maintain access for vehicular and pedestrian traffic as required for other construction activities.

PART 2 - PRODUCTS

2.1 MANUFACTURERS

- A. In other Part 2 articles where titles below introduce lists, the following requirements apply to product selection:
 - 1. Available Products: Subject to compliance with requirements, products that may be incorporated into the Work include, but are not limited to, products specified.
 - 2. Available Manufacturers: Subject to compliance with requirements, manufacturers offering products that may be incorporated into the Work include, but are not limited to, manufacturers specified.

2.2 FORMS

- A. Form Materials: Plywood, metal, metal-framed plywood, or other approved panel-type materials to provide full-depth, continuous, straight, smooth exposed surfaces.
 - 1. Use flexible or curved forms for curves with a radius 100 feet or less.
- B. Form-Release Agent: Commercially formulated form-release agent that will not bond with, stain, or adversely affect concrete surfaces and will not impair subsequent treatments of concrete surfaces.

2.3 STEEL REINFORCEMENT

- A. Plain-Steel Welded Wire Reinforcement: ASTM A 185, fabricated from as-drawn steel wire into flat sheets.
- B. Reinforcing Bars: ASTM A 615/A 615M, Grade 60; deformed.
- C. Plain Steel Wire: ASTM A 82, galvanized.
- D. Joint Dowel Bars: Plain steel bars, ASTM A 615/A 615M, Grade 60. Cut bars true to length with ends square and free of burrs.
- E. Tie Bars: ASTM A 615/A 615M, Grade 60, deformed.

CONCRETE TEE PADS AND SIGN POSTS FOR DISC GOLF COURSE

- F. Hook Bolts: ASTM A 307, Grade A, internally and externally threaded. Design hook-bolt joint assembly to hold coupling against pavement form and in position during concreting operations, and to permit removal without damage to concrete or hook bolt.
- G. Bar Supports: Bolsters, chairs, spacers, and other devices for spacing, supporting, and fastening reinforcing bars, welded wire reinforcement, and dowels in place. Manufacture bar supports according to CRSI's "Manual of Standard Practice" from steel wire, plastic, or precast concrete of greater compressive strength than concrete, and as follows:
 - 1. Equip wire bar supports with sand plates or horizontal runners where base material will not support chair legs.

2.4 CONCRETE MATERIALS

- A. Cementitious Material: Use the following cementitious materials, of the same type, brand, and source throughout the Project:
 - 1. Portland Cement: ASTM C 150, Type I, gray. Supplement with the following:
 - a. Fly Ash: ASTM C 618, Class F.
- B. Normal-Weight Aggregates: ASTM C 33, Class 4S coarse aggregate, uniformly graded. Provide aggregates from a single source with documented service record data of at least 10 years' satisfactory service in similar pavement applications and service conditions using similar aggregates and cementitious materials.
 - 1. Maximum Coarse-Aggregate Size: 1-1/2 inches nominal.
 - 2. Fine Aggregate: Free of materials with deleterious reactivity to alkali in cement.
- C. Water: ASTM C 94/C 94M.
- D. Air-Entraining Admixture: ASTM C 260.
- E. Chemical Admixtures: Provide admixtures certified by manufacturer to be compatible with other admixtures and to contain not more than 0.1 percent water-soluble chloride ions by mass of cementitious material.
 - 1. Water-Reducing Admixture: ASTM C 494/C 494M, Type A.
 - 2. Retarding Admixture: ASTM C 494/C 494M, Type B.
 - 3. Water-Reducing and Retarding Admixture: ASTM C 494/C 494M, Type D.
 - 4. High-Range, Water-Reducing Admixture: ASTM C 494/C 494M, Type F.
 - 5. High-Range, Water-Reducing and Retarding Admixture: ASTM C 494/C 494M, Type G.
 - 6. Plasticizing and Retarding Admixture: ASTM C 1017/C 1017M, Type II.

CONCRETE TEE PADS AND SIGN POSTS FOR DISC GOLF COURSE

2.5 CURING MATERIALS

- A. Absorptive Cover: AASHTO M 182, Class 2, burlap cloth made from jute or kenaf, weighing approximately 9 oz./sq. yd. dry.
- B. Moisture-Retaining Cover: ASTM C 171, polyethylene film or white burlap-polyethylene sheet.
- C. Water: Potable.
- D. Evaporation Retarder: Waterborne, monomolecular film forming; manufactured for application to fresh concrete.
 - 1. Available Products:
 - a. Axim Concrete Technologies; Cimfilm.
 - b. Burke by Edeco; BurkeFilm.
 - c. ChemMasters; Spray-Film.
 - d. Conspec Marketing & Manufacturing Co., Inc.; Aquafilm.
 - e. Dayton Superior Corporation; Sure Film.
 - f. Euclid Chemical Company (The); Eucobar.
 - g. Kaufman Products, Inc.; Vapor Aid.
 - h. Lambert Corporation; Lambco Skin.
 - i. L&M Construction Chemicals, Inc.; E-Con.
 - j. MBT Protection and Repair, ChemRex Inc.; Confilm.
 - k. Meadows, W. R., Inc.; Sealtight Evapre.
 - l. Metalcrete Industries; Waterhold.
 - m. Nox-Crete Products Group, Kinsman Corporation; Monofilm.
 - n. Sika Corporation, Inc.; SikaFilm.
 - o. Symons Corporation; Finishing Aid.
 - p. Vexcon Chemicals, Inc.; Certi-Vex EnvioAssist.
- E. Clear Waterborne Membrane-Forming Curing Compound: ASTM C 309, Type 1, Class B.
 - 1. Available Products:
 - a. Anti-Hydro International, Inc.; AH Curing Compound #2 DR WB.
 - b. Burke by Edoko; Aqua Resin Cure.
 - c. ChemMasters; Safe-Cure Clear.
 - d. Conspec Marketing & Manufacturing Co., Inc.; W.B. Resin Cure.
 - e. Dayton Superior Corporation; Day Chem Rez Cure (J-11-W).
 - f. Euclid Chemical Company (The); Kurez DR VOX.
 - g. Kaufman Products, Inc.; Thinfilm 420.
 - h. Lambert Corporation; Aqua Kure-Clear.
 - i. L&M Construction Chemicals, Inc.; L&M Cure R.
 - j. Meadows, W. R., Inc.; 1100 Clear.
 - k. Nox-Crete Products Group, Kinsman Corporation; Resin Cure E.
 - l. Symons Corporation; Resi-Chem Clear.
 - m. Tamms Industries Inc.; Horncure WB 30.
 - n. Unitex; Hydro Cure 309.

CONCRETE TEE PADS AND SIGN POSTS FOR DISC GOLF COURSE

- o. Vexcon Chemicals, Inc.; Certi-Vex Enviocure 100.

2.6 RELATED MATERIALS

- A. Expansion- and Isolation-Joint-Filler Strips: ASTM D 1751, asphalt-saturated cellulosic fiber or ASTM D 1752, cork or self-expanding cork.
 - 1. If an asphaltic fiber joint filler is utilized, provide an acceptable polyethylene bond breaker tape where joint sealant is indicated.
- B. Epoxy Bonding Adhesive: ASTM C 881, two-component epoxy resin, capable of humid curing and bonding to damp surfaces, of class suitable for application temperature and of grade to requirements, and as follows:
 - 1. Types I and II, non-load bearing, for bonding hardened or freshly mixed concrete to hardened concrete.
- C. Chemical Surface Retarder: Water-soluble, liquid-set retarder with color dye, for horizontal concrete surface application, capable of temporarily delaying final hardening of concrete to a depth of 1/8 to 1/4 inch.
 - 1. Available Products:
 - a. Burke by Edeco; True Etch Surface Retarder.
 - b. ChemMasters; Exposee.
 - c. Conspec Marketing & Manufacturing Co., Inc.; Delay S.
 - d. Euclid Chemical Company (The); Surface Retarder S.
 - e. Kaufman Products, Inc.; Expose.
 - f. Metalcrete Industries; Surfard.
 - g. Nox-Crete Products Group, Kinsman Corporation; Crete-Nox TA.
 - h. Scofield, L. M. Company; Lithotex.
 - i. Sika Corporation, Inc.; Rugasol-S.
 - j. Vexcon Chemicals, Inc.; Certi-Vex Envioset.

2.7 CONCRETE MIXTURES

- A. Prepare design mixtures, proportioned according to ACI 301, for each type and strength of normal-weight concrete determined by either laboratory trial mixes or field experience.
 - 1. Use a qualified independent testing agency for preparing and reporting proposed concrete mixture designs for the trial batch method.
- B. Proportion mixtures to provide normal-weight concrete with the following properties:
 - 1. Compressive Strength (28 Days): 4000 psi.
 - 2. Maximum Water-Cementitious Materials Ratio at Point of Placement: 0.45.
 - 3. Slump Limit: 4 inches, plus or minus 1 inch.

CONCRETE TEE PADS AND SIGN POSTS FOR DISC GOLF COURSE

- C. Add air-entraining admixture at manufacturer's prescribed rate to result in normal-weight concrete at point of placement having an air content as follows:
 - 1. Air Content: 6 1/2 percent plus or minus 1.5 percent for 1-1/2-inch nominal maximum aggregate size.
- D. Limit water-soluble, chloride-ion content in hardened concrete to 0.15 percent by weight of cement.
- E. Chemical Admixtures: Use admixtures according to manufacturer's written instructions.
 - 1. Use high-range, high-range, water-reducing and retarding admixture in concrete, as required, for placement and workability.
 - 2. Use water-reducing and retarding admixture when required by high temperatures, low humidity, or other adverse placement conditions.
- F. Cementitious Materials: Limit percentage, by weight, of cementitious materials other than portland cement according to ACI 301 requirements for concrete exposed to deicing chemicals.
 - 1. Fly Ash or Pozzolan: 15 percent.

2.8 CONCRETE MIXING

- A. Ready-Mixed Concrete: Measure, batch, and mix concrete materials and concrete according to ASTM C 94/C 94M. Furnish batch certificates for each batch discharged and used in the Work.
 - 1. When air temperature is between 85 deg F and 90 deg F, reduce mixing and delivery time from 1-1/2 hours to 75 minutes; when air temperature is above 90 deg F, reduce mixing and delivery time to 60 minutes.

PART 3 - EXECUTION

3.1 EXAMINATION

- A. Examine exposed subgrades and subbase surfaces for compliance with requirements for dimensional, grading, and elevation tolerances.
- B. Proof-roll prepared subbase surface below concrete pavements with heavy pneumatic-tired equipment to identify soft pockets and areas of excess yielding.
 - 1. Completely proof-roll subbase in one direction and repeat in perpendicular direction. Limit vehicle speed to 3 mph.
 - 2. Proof-roll with a loaded 10-wheel tandem-axle dump truck weighing not less than 15 tons.
 - 3. Subbase with soft spots and areas of pumping or rutting exceeding depth of 1/2 inch require correction according to requirements in Division 31 Section "Earth Moving."

CONCRETE TEE PADS AND SIGN POSTS FOR DISC GOLF COURSE

- C. Proceed with concrete pavement operations only after nonconforming conditions have been corrected and subgrade is ready to receive pavement.

3.2 PREPARATION

- A. Remove loose material from compacted subbase surface immediately before placing concrete.

3.3 EDGE FORMS AND SCREED CONSTRUCTION

- A. Set, brace, and secure edge forms, bulkheads, and intermediate screed guides for pavement to required lines, grades, and elevations. Install forms to allow continuous progress of work and so forms can remain in place at least 24 hours after concrete placement.
- B. Clean forms after each use and coat with form-release agent to ensure separation from concrete without damage.

3.4 STEEL REINFORCEMENT

- A. General: Comply with CRSI's "Manual of Standard Practice" for fabricating, placing, and supporting reinforcement.
- B. Clean reinforcement of loose rust and mill scale, earth, ice, or other bond-reducing materials.
- C. Arrange, space, and securely tie bars and bar supports to hold reinforcement in position during concrete placement. Maintain minimum cover to reinforcement.
- D. Install welded wire reinforcement in lengths as long as practicable. Lap adjoining pieces at least one full mesh, and lace splices with wire. Offset laps of adjoining widths to prevent continuous laps in either direction.
- E. Install fabricated bar mats in lengths as long as practicable. Handle units to keep them flat and free of distortions. Straighten bends, kinks, and other irregularities, or replace units as required before placement. Set mats for a minimum 2-inch overlap of adjacent mats.

3.5 JOINTS

- A. General: Form construction, isolation, and contraction joints and tool edgings true to line with faces perpendicular to surface plane of concrete. Construct transverse joints at right angles to centerline, unless otherwise indicated.
 - 1. When joining existing pavement, place transverse joints to align with previously placed joints, unless otherwise indicated.
- B. Construction Joints: Set construction joints at side and end terminations of pavement and at locations where pavement operations are stopped for more than one-half hour unless pavement terminates at isolation joints.

CONCRETE TEE PADS AND SIGN POSTS FOR DISC GOLF COURSE

1. Continue steel reinforcement across construction joints, unless otherwise indicated. Do not continue reinforcement through sides of pavement strips, unless otherwise indicated.
 2. Provide tie bars at sides of pavement strips where indicated.
 3. Butt Joints: Use epoxy bonding adhesive at joint locations where fresh concrete is placed against hardened or partially hardened concrete surfaces.
 4. Keyed Joints: Provide preformed keyway-section forms or bulkhead forms with keys, unless otherwise indicated. Embed keys at least 1-1/2 inches into concrete.
 5. Doweled Joints: Install dowel bars and support assemblies at joints where indicated. Lubricate or asphalt-coat one-half of dowel length to prevent concrete bonding to one side of joint.
- C. Isolation Joints: Form isolation joints of preformed joint-filler strips abutting concrete curbs, catch basins, manholes, inlets, structures, walks, other fixed objects, and where indicated.
1. Locate expansion joints at intervals of 50 feet, unless otherwise indicated.
 2. Extend joint fillers full width and depth of joint.
 3. Terminate joint filler not less than 1/2 inch or more than 1 inch below finished surface if joint sealant is indicated.
 4. Place top of joint filler flush with finished concrete surface if joint sealant is not indicated.
 5. Furnish joint fillers in one-piece lengths. Where more than one length is required, lace or clip joint-filler sections together.
 6. Protect top edge of joint filler during concrete placement with metal, plastic, or other temporary preformed cap. Remove protective cap after concrete has been placed on both sides of joint.
- D. Contraction Joints: Form weakened-plane contraction joints, sectioning concrete into areas as indicated. Construct contraction joints for a depth equal to at least one-fourth of the concrete thickness, as follows to match jointing of existing adjacent concrete pavement:
1. Grooved Joints: Form contraction joints after initial floating by grooving and finishing each edge of joint with grooving tool to a 1/4-inch radius. Repeat grooving of contraction joints after applying surface finishes. Eliminate groover marks on concrete surfaces.
 2. Sawed Joints: Form contraction joints with power saws equipped with shatterproof abrasive or diamond-rimmed blades. Cut 1/8-inch- wide joints into concrete when cutting action will not tear, abrade, or otherwise damage surface and before developing random contraction cracks.
 3. Doweled Contraction Joints: Install dowel bars and support assemblies at joints where indicated. Lubricate or asphalt coat one-half of dowel length to prevent concrete bonding to one side of joint.
- E. Edging: Tool edges of pavement, gutters, curbs, and joints in concrete after initial floating with an edging tool to a 1/4-inch radius. Repeat tooling of edges after applying surface finishes. Eliminate tool marks on concrete surfaces.

CONCRETE TEE PADS AND SIGN POSTS FOR DISC GOLF COURSE

3.6 CONCRETE PLACEMENT

- A. Inspection: Before placing concrete, inspect and complete formwork installation, steel reinforcement, and items to be embedded or cast in. Notify other trades to permit installation of their work.
- B. Remove snow, ice, or frost from subbase surface and reinforcement before placing concrete. Do not place concrete on frozen surfaces.
- C. Moisten subbase to provide a uniform dampened condition at time concrete is placed. Do not place concrete around manholes or other structures until they are at required finish elevation and alignment.
- D. Comply with ACI 301 requirements for measuring, mixing, transporting, and placing concrete.
- E. Do not add water to concrete during delivery or at Project site.
- F. Do not add water to fresh concrete after testing.
- G. Deposit and spread concrete in a continuous operation between transverse joints. Do not push or drag concrete into place or use vibrators to move concrete into place.
- H. Consolidate concrete according to ACI 301 by mechanical vibrating equipment supplemented by hand spading, rodding, or tamping.
 - 1. Consolidate concrete along face of forms and adjacent to transverse joints with an internal vibrator. Keep vibrator away from joint assemblies, reinforcement, or side forms. Use only square-faced shovels for hand spreading and consolidation. Consolidate with care to prevent dislocating reinforcement, dowels, and joint devices.
- I. Place concrete in two operations; strike off initial pour for entire width of placement and to the required depth below finish surface. Lay welded wire fabric or fabricated bar mats immediately in final position. Place top layer of concrete, strike off, and screed.
 - 1. Remove and replace concrete that has been placed for more than 15 minutes without being covered by top layer, or use bonding agent if approved by Architect.
- J. Screed pavement surfaces with a straightedge and strike off.
- K. Commence initial floating using bull floats or darbies to impart an open textured and uniform surface plane before excess moisture or bleed water appears on the surface. Do not further disturb concrete surfaces before beginning finishing operations or spreading surface treatments.
- L. Cold-Weather Placement: Comply with ACI 306.1 and as follows. Protect concrete work from physical damage or reduced strength that could be caused by frost, freezing actions, or low temperatures.
 - 1. When air temperature has fallen to or is expected to fall below 40 deg F, uniformly heat water and aggregates before mixing to obtain a concrete mixture temperature of not less than 50 deg F and not more than 80 deg F at point of placement.

CONCRETE TEE PADS AND SIGN POSTS FOR DISC GOLF COURSE

2. Do not use frozen materials or materials containing ice or snow.
 3. Do not use calcium chloride, salt, or other materials containing antifreeze agents or chemical accelerators unless otherwise specified and approved in mix designs.
- M. Hot-Weather Placement: Comply with ACI 301 and as follows when hot-weather conditions exist:
1. Cool ingredients before mixing to maintain concrete temperature below 90 deg F at time of placement. Chilled mixing water or chopped ice may be used to control temperature, provided water equivalent of ice is calculated to total amount of mixing water. Using liquid nitrogen to cool concrete is Contractor's option.
 2. Cover steel reinforcement with water-soaked burlap so steel temperature will not exceed ambient air temperature immediately before embedding in concrete.
 3. Fog-spray forms, steel reinforcement, and subgrade just before placing concrete. Keep subgrade moisture uniform without standing water, soft spots, or dry areas.

3.7 FLOAT FINISHING

- A. General: Do not add water to concrete surfaces during finishing operations.
- B. Float Finish: Begin the second floating operation when bleed-water sheen has disappeared and concrete surface has stiffened sufficiently to permit operations. Float surface with power-driven floats, or by hand floating if area is small or inaccessible to power units. Finish surfaces to true planes. Cut down high spots and fill low spots. Refloat surface immediately to uniform granular texture.
1. Medium-to-Fine-Textured Broom Finish: Draw a soft bristle broom across float-finished concrete surface perpendicular to line of traffic to provide a uniform, fine-line texture.
 2. Medium-to-Coarse-Textured Broom Finish: Provide a coarse finish by striating float-finished concrete surface 1/16 to 1/8 inch deep with a stiff-bristled broom, perpendicular to line of traffic.

3.8 CONCRETE PROTECTION AND CURING

- A. General: Protect freshly placed concrete from premature drying and excessive cold or hot temperatures.
- B. Comply with ACI 306.1 for cold-weather protection.
- C. Evaporation Retarder: Apply evaporation retarder to concrete surfaces if hot, dry, or windy conditions cause moisture loss approaching 0.2 lb/sq. ft. x h before and during finishing operations. Apply according to manufacturer's written instructions after placing, screeding, and bull floating or darbying concrete, but before float finishing.
- D. Begin curing after finishing concrete but not before free water has disappeared from concrete surface.

CONCRETE TEE PADS AND SIGN POSTS FOR DISC GOLF COURSE

- E. Curing Methods: Cure concrete by moisture curing, moisture-retaining-cover curing, curing compound, or a combination of these as follows:
1. Moist Curing: Keep surfaces continuously moist for not less than seven days with the following materials:
 - a. Water.
 - b. Continuous water-fog spray.
 - c. Absorptive cover, water saturated and kept continuously wet. Cover concrete surfaces and edges with 12-inch lap over adjacent absorptive covers.
 2. Moisture-Retaining-Cover Curing: Cover concrete surfaces with moisture-retaining cover for curing concrete, placed in widest practicable width, with sides and ends lapped at least 12 inches, and sealed by waterproof tape or adhesive. Immediately repair any holes or tears during curing period using cover material and waterproof tape.
 3. Curing Compound: Apply uniformly in continuous operation by power spray or roller according to manufacturer's written instructions. Recoat areas subjected to heavy rainfall within three hours after initial application. Maintain continuity of coating and repair damage during curing period.

3.9 PAVEMENT TOLERANCES

- A. Comply with tolerances of ACI 117 and as follows:

1. Elevation: 1/4 inch.
2. Thickness: Plus 3/8 inch, minus 1/4 inch.
3. Surface: Gap below 10-foot- long, unlevelled straightedge not to exceed 1/4 inch.
4. Lateral Alignment and Spacing of Tie Bars and Dowels: 1 inch.
5. Vertical Alignment of Tie Bars and Dowels: 1/4 inch.
6. Alignment of Tie-Bar End Relative to Line Perpendicular to Pavement Edge: 1/2 inch.
7. Alignment of Dowel-Bar End Relative to Line Perpendicular to Pavement Edge: Length of dowel 1/4 inch per 12 inches.
8. Joint Spacing: 3 inches.
9. Contraction Joint Depth: Plus 1/4 inch, no minus.
10. Joint Width: Plus 1/8 inch, no minus.

3.10 REPAIRS AND PROTECTION

- A. Remove and replace concrete pavement that is broken, damaged, or defective or that does not comply with requirements in this Section.
- B. Drill test cores, where directed by Architect, when necessary to determine magnitude of cracks or defective areas. Fill drilled core holes in satisfactory pavement areas with portland cement concrete bonded to pavement with epoxy adhesive.
- C. Protect concrete from damage. Exclude traffic from pavement for at least 14 days after placement. When construction traffic is permitted, maintain pavement as clean as possible by removing surface stains and spillage of materials as they occur.

CONCRETE TEE PADS AND SIGN POSTS FOR DISC GOLF COURSE

- D. Maintain concrete pavement free of stains, discoloration, dirt, and other foreign material. Sweep concrete pavement not more than two days before date scheduled for Substantial Completion inspections.

END OF SECTION 321313

CONCRETE TEE PADS AND SIGN POSTS FOR DISC GOLF COURSE

SECTION 321373 – CONCRETE PAVING JOINT SEALANTS

PART 1 - GENERAL

1.1 RELATED DOCUMENTS

- A. Drawings and general provisions of the Contract, including General, Supplementary and Special Conditions and Division 01 Specification Sections, apply to this Section.

1.2 SUMMARY

- A. This Section includes the following:
 - 1. Expansion and contraction joints within cement concrete pavement.
- B. Related Sections include the following:
 - 1. Division 07 Section "Joint Sealants" for sealing nontraffic and traffic joints in locations not specified in this Section.
 - 2. Division 32 Section "Concrete Paving" for constructing joints in concrete pavement.

1.3 SUBMITTALS

- A. Product Data: For each joint-sealant product indicated.
- B. Samples for Verification: For each type and color of joint sealant required. Install joint-sealant samples in 1/2-inch- wide joints formed between two 6-inch- long strips of material matching the appearance of exposed surfaces adjacent to joint sealants.
- C. Product Certificates: For each type of joint sealant and accessory, signed by product manufacturer.
- D. Qualification Data: For Installer.
- E. Compatibility and Adhesion Test Reports: From sealant manufacturer, indicating the following:
 - 1. Materials forming joint substrates and joint-sealant backings have been tested for compatibility and adhesion with joint sealants.
 - 2. Interpretation of test results and written recommendations for primers and substrate preparation needed for adhesion.
- F. Product Test Reports: Based on evaluation of comprehensive tests performed by a qualified testing agency, for sealants.

CONCRETE TEE PADS AND SIGN POSTS FOR DISC GOLF COURSE

1.4 QUALITY ASSURANCE

- A. Installer Qualifications: An employer of workers trained and approved by manufacturer.
- B. Source Limitations: Obtain each type of joint sealant through one source from a single manufacturer.
- C. Product Testing: Obtain test results for "Product Test Reports" Paragraph in "Submittals" Article from a qualified testing agency based on testing of current sealant products within a 36-month period preceding the Notice to Proceed with the Work.
 - 1. Testing Agency Qualifications: An independent testing agency qualified according to ASTM C 1021 for testing indicated, as documented according to ASTM E 548.

1.5 DELIVERY, STORAGE, AND HANDLING

- A. Deliver materials to Project site in original unopened containers or bundles with labels indicating manufacturer, product name and designation, color, expiration date, pot life, curing time, and mixing instructions for multicomponent materials.
- B. Store and handle materials to comply with manufacturer's written instructions to prevent their deterioration or damage due to moisture, high or low temperatures, contaminants, or other causes.

1.6 PROJECT CONDITIONS

- A. Do not proceed with installation of joint sealants under the following conditions:
 - 1. When ambient and substrate temperature conditions are outside limits permitted by joint-sealant manufacturer.
 - 2. When ambient and substrate temperature conditions are outside limits permitted by joint-sealant manufacturer or are below 40 deg F.
 - 3. When joint substrates are wet or covered with frost.
 - 4. Where joint widths are less than those allowed by joint-sealant manufacturer for applications indicated.
 - 5. Where contaminants capable of interfering with adhesion have not yet been removed from joint substrates.

PART 2 - PRODUCTS

2.1 MANUFACTURERS

- A. Available Products: Subject to compliance with requirements, products that may be incorporated into the Work include, but are not limited to, products listed in other Part 2 articles.

CONCRETE TEE PADS AND SIGN POSTS FOR DISC GOLF COURSE

2.2 MATERIALS, GENERAL

- A. Compatibility: Provide joint sealants, backing materials, and other related materials that are compatible with one another and with joint substrates under conditions of service and application, as demonstrated by joint-sealant manufacturer based on testing and field experience.
- B. Colors of Exposed Joint Sealants: As selected by Architect from manufacturer's full range.

2.3 COLD-APPLIED JOINT SEALANTS

- A. Multicomponent Jet-Fuel-Resistant Sealant for Concrete: Pourable, chemically curing elastomeric formulation complying with the following requirements for formulation and with ASTM C 920 for type, grade, class, and uses indicated:
 - 1. Urethane Formulation: Type M; Grade P; Class 12-1/2; Uses T, M, and, as applicable to joint substrates indicated, O.
 - a. Available Products:
 - 1) Pecora Corporation; Urexpan, Dynatred.
 - 2) Sonneborn, Div. of ChemRex, Inc.; Sonolastic SL 2.
 - B. Single-Component Jet-Fuel-Resistant Urethane Sealant for Concrete: Single-component, pourable, coal-tar-modified, urethane formulation complying with ASTM C 920 for Type S; Grade P; Class 25; Uses T, M, and, as applicable to joint substrates indicated, O.
 - 1. Available Products:
 - a. Sonneborn, Div. of ChemRex, Inc.; Sonolastic SL 1.
 - b. Tremco Sealant/Waterproofing Division; Vulkem 45SSL.

2.4 JOINT-SEALANT BACKER MATERIALS

- A. General: Provide joint-sealant backer materials that are nonstaining; are compatible with joint substrates, sealants, primers, and other joint fillers; and are approved for applications indicated by joint-sealant manufacturer based on field experience and laboratory testing.
- B. Round Backer Rods for Cold- and Hot-Applied Sealants: ASTM D 5249, Type 1, of diameter and density required to control sealant depth and prevent bottom-side adhesion of sealant.
- C. Backer Strips for Cold- and Hot-Applied Sealants: ASTM D 5249; Type 2; of thickness and width required to control sealant depth, prevent bottom-side adhesion of sealant, and fill remainder of joint opening under sealant.
- D. Round Backer Rods for Cold-Applied Sealants: ASTM D 5249, Type 3, of diameter and density required to control sealant depth and prevent bottom-side adhesion of sealant.

CONCRETE TEE PADS AND SIGN POSTS FOR DISC GOLF COURSE

2.5 PRIMERS

- A. Primers: Product recommended by joint-sealant manufacturer where required for adhesion of sealant to joint substrates indicated, as determined from preconstruction joint-sealant-substrate tests and field tests.

PART 3 - EXECUTION

3.1 EXAMINATION

- A. Examine joints indicated to receive joint sealants, with Installer present, for compliance with requirements for joint configuration, installation tolerances, and other conditions affecting joint-sealant performance.
 - 1. Proceed with installation only after unsatisfactory conditions have been corrected.

3.2 PREPARATION

- A. Surface Cleaning of Joints: Clean out joints immediately before installing joint sealants to comply with joint-sealant manufacturer's written instructions.
- B. Joint Priming: Prime joint substrates where indicated or where recommended in writing by joint-sealant manufacturer, based on preconstruction joint-sealant-substrate tests or prior experience. Apply primer to comply with joint-sealant manufacturer's written instructions. Confine primers to areas of joint-sealant bond; do not allow spillage or migration onto adjoining surfaces.

3.3 INSTALLATION OF JOINT SEALANTS

- A. General: Comply with joint-sealant manufacturer's written installation instructions for products and applications indicated, unless more stringent requirements apply.
- B. Sealant Installation Standard: Comply with recommendations in ASTM C 1193 for use of joint sealants as applicable to materials, applications, and conditions indicated.
- C. Install backer materials of type indicated to support sealants during application and at position required to produce cross-sectional shapes and depths of installed sealants relative to joint widths that allow optimum sealant movement capability.
 - 1. Do not leave gaps between ends of backer materials.
 - 2. Do not stretch, twist, puncture, or tear backer materials.
 - 3. Remove absorbent backer materials that have become wet before sealant application and replace them with dry materials.
- D. Install sealants using proven techniques that comply with the following and at the same time backings are installed:
 - 1. Place sealants so they directly contact and fully wet joint substrates.

CONCRETE TEE PADS AND SIGN POSTS FOR DISC GOLF COURSE

2. Completely fill recesses provided for each joint configuration.
 3. Produce uniform, cross-sectional shapes and depths relative to joint widths that allow optimum sealant movement capability.
- E. Tooling of Nonsag Sealants: Immediately after sealant application and before skinning or curing begins, tool sealants according to requirements specified below to form smooth, uniform beads of configuration indicated; to eliminate air pockets; and to ensure contact and adhesion of sealant with sides of joint.
1. Remove excess sealants from surfaces adjacent to joint.
 2. Use tooling agents that are approved in writing by joint-sealant manufacturer and that do not discolor sealants or adjacent surfaces.
- F. Provide joint configuration to comply with joint-sealant manufacturer's written instructions, unless otherwise indicated.
- G. Provide recessed joint configuration for silicone sealants of recess depth and at locations indicated.

3.4 CLEANING

- A. Clean off excess sealants or sealant smears adjacent to joints as the Work progresses by methods and with cleaning materials approved by manufacturers of joint sealants and of products in which joints occur.

3.5 PROTECTION

- A. Protect joint sealants during and after curing period from contact with contaminating substances and from damage resulting from construction operations or other causes so sealants are without deterioration or damage at time of Substantial Completion. If, despite such protection, damage or deterioration occurs, cut out and remove damaged or deteriorated joint sealants immediately and replace with joint sealant so installations with repaired areas are indistinguishable from the original work.

3.6 WARRANTY

- A. Joint sealants shall come with a minimum five (5) year warranty for correction of deteriorated and / or failed sealants.

END OF SECTION 321373

CONCRETE TEE PADS AND SIGN POSTS FOR DISC GOLF COURSE

SECTION 32 92 00 - TURF AND GRASSES

PART 1 - GENERAL

1.1 RELATED DOCUMENTS

- A. Drawings and general provisions of the Contract, including General, Supplementary and Special Conditions and Division 01 Specification Sections, apply to this Section.

1.2 SUMMARY

- A. Section Includes:

- 1. Hydroseeding
- 2. Sodding.
- 3. Lawn renovation.
- 4. Erosion-control material(s).

- B. Related Sections:

- 1. Division 31 Section "Site Clearing" for topsoil stripping and stockpiling.
- 2. Division 31 Section "Earth Moving" for excavation, filling and backfilling, and rough grading.

1.3 DEFINITIONS

- A. Finish Grade: Elevation of finished surface of planting soil.
- B. Planting Soil: Native or imported topsoil, manufactured topsoil, or surface soil modified to become topsoil; mixed with soil amendments.
- C. Subgrade: Surface or elevation of subsoil remaining after completing excavation, or top surface of a fill or backfill immediately beneath planting soil.
- D. Subsoil: All soil beneath the topsoil layer of the soil profile, and typified by the lack of organic matter and soil organisms.

1.4 SUBMITTALS

- A. Product Data: For each type of product indicated.
- B. Certification of Grass Seed: From seed vendor for each grass-seed monostand or mixture stating the botanical and common name and percentage by weight of each species and variety, and percentage of purity, germination, and weed seed. Include the year of production and date of packaging.

CONCRETE TEE PADS AND SIGN POSTS FOR DISC GOLF COURSE

1. Certification of each seed mixture for turfgrass sod, identifying source, including name and telephone number of supplier.
- C. Qualification Data: For qualified landscape Installer.
- D. Product Certificates: For soil amendments and fertilizers, from manufacturer.
- E. Material Test Reports: For existing surface soil.
- F. Samples for Verification: For each of the following:
 1. Erosion Control Blanket: 12 by 12 inches.
- G. Planting Schedule: Indicating anticipated planting dates for each type of planting.

1.5 QUALITY ASSURANCE

- A. Installer Qualifications: A qualified landscape installer whose work has resulted in successful lawn and meadow establishment.
 1. Installer's Field Supervision: Require Installer to maintain an experienced full-time supervisor on Project site when planting is in progress.
 2. Maintenance Proximity: Not more than two hours' normal travel time from Installer's place of business to Project site.
- B. Soil-Testing Laboratory Qualifications: An independent laboratory, recognized by the State Department of Agriculture, with the experience and capability to conduct the testing indicated and that specializes in types of tests to be performed.
- C. Topsoil Analysis: Furnish soil analysis by a qualified soil-testing laboratory stating percentages of organic matter; gradation of sand, silt, and clay content; cation exchange capacity; deleterious material; pH; and mineral and plant-nutrient content of topsoil.
 1. Report suitability of topsoil for lawn growth. State-recommended quantities of nitrogen, phosphorus, and potash nutrients and soil amendments to be added to produce satisfactory topsoil.
- D. Preinstallation Conference: Conduct conference at Project site.

1.6 DELIVERY, STORAGE, AND HANDLING

- A. Seed: Deliver seed in original sealed, labeled, and undamaged containers.
- B. Sod: Harvest, deliver, store, and handle sod according to requirements in TPI's "Specifications for Turfgrass Sod Materials" and "Specifications for Turfgrass Sod Transplanting and Installation" in its "Guideline Specifications to Turfgrass Sodding." Deliver sod in time for planting within 24 hours of harvesting. Protect sod from breakage and drying.

CONCRETE TEE PADS AND SIGN POSTS FOR DISC GOLF COURSE

1.7 PROJECT CONDITIONS

- A. Planting Restrictions: Plant during one of the following periods. Coordinate planting periods with initial maintenance periods to provide required maintenance from date of Substantial Completion.
 - 1. Summer Planting: July 1st – September 1st
- B. Weather Limitations: Proceed with planting only when existing and forecasted weather conditions permit.

1.8 MAINTENANCE SERVICE

- A. Initial Lawn Maintenance Service: Provide full maintenance by skilled employees of landscape Installer. Maintain as required in Part 3. Begin maintenance immediately after each area is planted and continue until acceptable lawn is established, but for not less than the following periods:
 - 1. Seeded Lawns: 60 days from date of Project Substantial Completion.
 - a. When initial maintenance period has not elapsed before end of planting season, or if lawn is not fully established, continue maintenance during next planting season.
 - 2. Sodded Lawns: 60 days from date of Project Substantial Completion.

PART 2 - PRODUCTS

2.1 SEED FOR HYDROSEEDING

- A. Grass Seed: Fresh, clean, dry, new-crop seed complying with AOSA's "Journal of Seed Technology; Rules for Testing Seeds" for purity and germination tolerances.
- B. Seed Species: Seed of grass species as follows, with not less than 95 percent germination, not less than 85 percent pure seed, and not more than 0.5 percent weed seed:
 - 1. Sun to Partial Shade: Proportioned by weight as follows:
 - a. 85 percent blend three species of Turf Type Tall Fescues. Cultivars shall be specifically tolerant for summer season seeding.
 - b. 15 percent perennial ryegrass.
 - 2. Seed Grade: Certified Turf Quality.
 - 3. Application Rate: 2.5 lbs/1000 sf
 - 4. Seed shall be weed free, fresh, re-cleaned, Grade A, new crop.
- C. Hydro-Mulch:
 - 1. Cellulose wood fiber with no growth or germination inhibiting factors, dyed green. Material shall have equilibrium air-dry moisture content of twelve (12) percent, plus or minus two (2) percent, at time of manufacture.

CONCRETE TEE PADS AND SIGN POSTS FOR DISC GOLF COURSE

2. Fiber shall disperse rapidly in water forming homogeneous slurry and remaining in such state when agitated in hydro-mulching equipment.
- D. Binders:
 1. Tackifier to bind soil and mulch together to prevent erosion.
- E. Fungicide for use with Hydroseeding application.
- F. Fertilizer: 16-20-0.

2.2 MIXES FOR HYDROSEEDING

- A. General:
 1. Amount of hydro-mulch shall be 1800 lbs per acre.
 2. Add water as necessary to provide suitable slurry mixture.
 3. Add fungicide at rates recommended by Manufacturer on installations made between 1st of June and 30 September.

2.3 TURFGRASS SOD

- A. Turfgrass Sod: Certified, complying with TPI's "Specifications for Turfgrass Sod Materials" in its "Guideline Specifications to Turfgrass Sodding." Furnish viable sod of uniform density, color, and texture, strongly rooted, and capable of vigorous growth and development when planted. Do not use sod with netting.
- B. Turfgrass Species: Sod of grass species as follows, with not less than 95 percent germination, not less than 85 percent pure seed, and not more than 0.5 percent weed seed:
 1. Full Sun: Blend of three "fine blade turf type" Tall Fescue cultivars acceptable to the Architect.

2.4 TOPSOIL

- A. Topsoil: ASTM D 5268, pH range of 5.5 to 7, a minimum of 2 percent organic material content; free of stones 1 inch or larger in any dimension and other extraneous materials harmful to plant growth.
 1. Topsoil Source: Reuse surface soil stockpiled on-site. Verify suitability of stockpiled surface soil to produce topsoil. Clean surface soil of roots, plants, sod, stones, clay lumps, and other extraneous materials harmful to plant growth.
 - a. Supplement with imported or manufactured topsoil from off-site sources when quantities are insufficient. Obtain topsoil displaced from naturally well-drained construction or mining sites where topsoil occurs at least 4 inches deep; do not obtain from bogs or marshes.

CONCRETE TEE PADS AND SIGN POSTS FOR DISC GOLF COURSE

2.5 INORGANIC SOIL AMENDMENTS

- A. Lime: ASTM C 602, agricultural limestone containing a minimum of 80 percent calcium carbonate equivalent and as follows:
 - 1. Class: T, with a minimum of 99 percent passing through No. 8 sieve and a minimum of 75 percent passing through No. 60 sieve.

2.6 PLANTING ACCESSORIES

- A. Selective Herbicides: EPA registered and approved, of type recommended by manufacturer for application.

2.7 FERTILIZER

- A. Commercial Fertilizer: Commercial-grade complete fertilizer of neutral character, consisting of fast- and slow-release nitrogen, 50 percent derived from natural organic sources of urea formaldehyde, phosphorous, and potassium in the following composition:
 - 1. Composition: Nitrogen, phosphorous, and potassium in amounts recommended in soil reports from a qualified soil-testing agency.

2.8 MULCHES

- A. Straw Mulch: Provide air-dry, clean, mildew- and seed-free, salt hay or threshed straw of wheat, rye, oats, or barley.
- B. Asphalt Emulsion: ASTM D 977, Grade SS-1; nontoxic and free of plant-growth or germination inhibitors.

2.9 EROSION-CONTROL MATERIALS

- A. Erosion Control Blankets: For slopes exceeding 6:1 and not indicated to be sodded. Short term, 100% biodegradable double net straw fiber erosion control blanket designed for use on moderate slopes for up to 1 year. Blanket shall be sewn together on 1.5" centers, FHWA FP-03, Type 2D erosion control blanket for slopes up to 2:1. 100% agricultural straw fiber matrix, straw applied at a rate of .5lbs/SY, top and bottom leno woven biodegradable nets with a mesh size of .5x1 inches, 100% biodegradable leno woven net, thread and matrix. Erosion Control Blanket S32BD or an equivalent product.

2.10 PLANTING SOIL MIX

- A. Planting Soil Mix: Topsoil mixed with the following soil amendments and fertilizers in the following quantities:
 - 1. Weight of Lime per 1000 Sq. Ft.: As determined by Soil Test.
 - 2. Weight of Sulfur per 1000 Sq. Ft.: As determined by Soil Test..

CONCRETE TEE PADS AND SIGN POSTS FOR DISC GOLF COURSE

3. Weight of Commercial Fertilizer per 1000 Sq. Ft.: As determined by Soil Test.

PART 3 - EXECUTION

3.1 EXAMINATION

- A. Examine areas to receive lawns and grass for compliance with requirements and other conditions affecting performance.
- B. Proceed with installation only after unsatisfactory conditions have been corrected.

3.2 PREPARATION

- A. Protect structures, utilities, sidewalks, pavements, and other facilities, trees, shrubs, and plantings from damage caused by planting operations.
 1. Protect adjacent and adjoining areas from hydroseeding and hydromulching overspray.
 2. Protect grade stakes set by others until directed to remove them.
- B. Provide erosion-control measures to prevent erosion or displacement of soils and discharge of soil-bearing water runoff or airborne dust to adjacent properties and walkways.

3.3 FIELD QUALITY CONTROL

- A. Field Inspections:
 1. Seeded areas will be accepted at final inspection if:
 - a. Seeded areas are properly established.
 - b. Lawn is free of bare and dead spots and is without weeds.
 - c. No surface soil is visible when grass has been cut to height of 2 inches.
 - d. Seeded areas have been mowed a minimum of twice.

3.4 LAWN PREPARATION

- A. Limit lawn subgrade preparation to areas to be planted.
- B. Newly Graded Subgrades: Loosen subgrade to a minimum depth of 6 inches. Remove stones larger than 1 inch in any dimension and sticks, roots, rubbish, and other extraneous matter and legally dispose of them off Owner's property.
 1. Spread topsoil, apply soil amendments and fertilizer on surface, and thoroughly blend planting soil mix.
 - a. Delay mixing fertilizer with planting soil if planting will not proceed within a few days.
 - b. Mix lime with dry soil before mixing fertilizer.

CONCRETE TEE PADS AND SIGN POSTS FOR DISC GOLF COURSE

2. Spread planting soil mix to a depth of 6 inches but not less than required to meet finish grades after light rolling and natural settlement. Do not spread if planting soil or subgrade is frozen, muddy, or excessively wet.
 - a. Spread approximately 1/2 the thickness of planting soil mix over loosened subgrade. Mix thoroughly into top 2 inches of subgrade. Spread remainder of planting soil mix.
 - b. Reduce elevation of planting soil to allow for soil thickness of sod.
- C. Unchanged Subgrades: If lawns are to be planted in areas unaltered or undisturbed by excavating, grading, or surface-soil stripping operations, prepare surface soil as follows:
 1. Remove existing grass, vegetation, and turf. Do not mix into surface soil.
 2. Loosen surface soil to a depth of at least 6 inches. Apply soil amendments and fertilizers according to planting soil mix proportions and mix thoroughly into top 4 inches of soil. Till soil to a homogeneous mixture of fine texture.
 - a. Apply fertilizer directly to surface soil before loosening.
 3. Remove stones larger than 1 inch in any dimension and sticks, roots, trash, and other extraneous matter.
 4. Legally dispose of waste material, including grass, vegetation, and turf, off Owner's property.
- D. Finish Grading: Grade planting areas to a smooth, uniform surface plane with loose, uniformly fine texture. Grade to within plus or minus 1/2 inch of finish elevation. Roll and rake, remove ridges, and fill depressions to meet finish grades. Limit finish grading to areas that can be planted in the immediate future.
- E. Moisten prepared lawn areas before planting if soil is dry. Water thoroughly and allow surface to dry before planting. Do not create muddy soil.
- F. Before planting, restore areas if eroded or otherwise disturbed after finish grading.

3.5 PREPARATION FOR EROSION-CONTROL MATERIALS

- A. Prepare area as specified in "Lawn Preparation" Article.
- B. For erosion-control blanket and turf reinforcement mat, install from top of slope, working downward, and as recommended by material manufacturer for site conditions. Fasten as recommended by material manufacturer.
- C. Moisten prepared area before planting if surface is dry. Water thoroughly and allow surface to dry before planting. Do not create muddy soil.

3.6 HYDROSEEDING

- A. Interface With Other Work:
 1. Do not commence work of this Section until work of section 312000 Earth Moving has been completed and approved.

CONCRETE TEE PADS AND SIGN POSTS FOR DISC GOLF COURSE

- B. Tolerances:
 - 1. Final grade of soil after seeding of lawn areas is complete shall be one inch below top of adjacent pavement of any kind.
- C. After lawn areas are graded, apply specified slurry mix with machine capable of continuously mixing slurry and providing an application meeting Contract Document requirements. Hydro-mulch shall form an absorptive mat, but not a plant inhibiting membrane, which will allow water to percolate into underlying soil.
- D. Post Application Watering:
 - 1. Allow slurry mixture to 'set.'
 - 2. Water hydro-seeded areas sufficiently to insure proper seed germination, but not cause erosion or slope failure. Repeat watering at regular intervals to keep seed germinating and growing until plantings are established. Note hydroseeding will take place in summer months and Contractor shall water accordingly to provide establishment in hot, dry conditions.
 - 3. After plantings are established, decrease frequency and increase amount of water per application as necessary to meet plant water requirements.
- E. If fungicide has been applied with slurry mix, make a second application of fungicide fourteen (14) days after initial application.

3.7 SODDING

- A. Lay sod within 24 hours of harvesting. Do not lay sod if dormant or if ground is frozen or muddy.
- B. Lay sod to form a solid mass with tightly fitted joints. Butt ends and sides of sod; do not stretch or overlap. Stagger sod strips or pads to offset joints in adjacent courses. Avoid damage to subgrade or sod during installation. Tamp and roll lightly to ensure contact with subgrade, eliminate air pockets, and form a smooth surface. Work sifted soil or fine sand into minor cracks between pieces of sod; remove excess to avoid smothering sod and adjacent grass.
 - 1. Lay sod across angle of slopes exceeding 1:3.
 - 2. Anchor sod on slopes exceeding 1:6 with wood pegs spaced as recommended by sod manufacturer but not less than 2 anchors per sod strip to prevent slippage.
- C. Saturate sod with fine water spray within two hours of planting. During first week after planting, water daily or more frequently as necessary to maintain moist soil to a minimum depth of 1-1/2 inches below sod.

3.8 LAWN RENOVATION

- A. Renovate existing lawn damaged by Contractor's operations, such as storage of materials or equipment and movement of vehicles.
 - 1. Reestablish lawn where settlement or washouts occur or where minor regrading is required.
 - 2. Provide new topsoil as required.

CONCRETE TEE PADS AND SIGN POSTS FOR DISC GOLF COURSE

3. Lawn renovation shall be done by hydroseeding.
 - B. Remove sod and vegetation from diseased or unsatisfactory lawn areas; do not bury in soil.
 - C. Remove topsoil containing foreign materials resulting from Contractor's operations, including oil drippings, fuel spills, stone, gravel, and other construction materials, and replace with new topsoil.
 - D. Mow, dethatch, core aerate, and rake existing lawn.
 - E. Remove weeds before hydroseeding. Where weeds are extensive, apply selective herbicides as required. Do not use pre-emergence herbicides.
 - F. Remove waste and foreign materials, including weeds, soil cores, grass, vegetation, and turf, and legally dispose of them off Owner's property.
 - G. Till stripped, bare, and compacted areas thoroughly to a soil depth of 6 inches.
 - H. Apply soil amendments and initial fertilizers required for establishing new lawns and mix thoroughly into top 4 inches of existing soil. Provide new planting soil to fill low spots and meet finish grades.
 - I. Apply seed and protect with straw mulch as required for new lawns.
 - J. Water newly planted areas and keep moist until new lawn is established.

3.9 LAWN MAINTENANCE

- A. Maintain and establish lawn by watering, fertilizing, weeding, mowing, trimming, replanting, and other operations. Roll, regrade, and replant bare or eroded areas and remulch to produce a uniformly smooth lawn. Provide materials and installation the same as those used in the original installation.
 1. In areas where mulch has been disturbed by wind or maintenance operations, add new mulch and anchor as required to prevent displacement.
- B. Watering: Provide and maintain temporary piping, hoses, and lawn-watering equipment to convey water from sources and to keep lawn uniformly moist to a depth of 4 inches.
 1. Schedule watering to prevent wilting, puddling, erosion, and displacement of seed or mulch. Lay out temporary watering system to avoid walking over muddy or newly planted areas.
 2. Water lawn with fine spray at a minimum rate of 1 inch per week unless rainfall precipitation is adequate.
- C. Mow lawn as soon as top growth is tall enough to cut. Repeat mowing to maintain specified height without cutting more than 1/3 of grass height. Remove no more than 1/3 of grass-leaf growth in initial or subsequent mowings. Do not delay mowing until grass blades bend over and become matted. Do not mow when grass is wet. Schedule initial and subsequent mowings to maintain the following grass height:

CONCRETE TEE PADS AND SIGN POSTS FOR DISC GOLF COURSE

1. Mow grass to a height of 2 to 3 inches.
- D. Lawn Postfertilization: Apply fertilizer after initial mowing and when grass is dry.
1. Use fertilizer that will provide actual nitrogen of at least 1 lb/1000 sq. ft. to lawn area.

3.10 SATISFACTORY LAWNS

- A. Lawn installations shall meet the following criteria as determined by Architect:
1. Satisfactory Seeded Lawn: At end of maintenance period, a healthy, uniform, close stand of grass has been established, free of weeds and surface irregularities, with coverage exceeding 90 percent over any 10 sq. ft. and bare spots not exceeding 5 by 5 inches.
 2. Satisfactory Sodded Lawn: At end of maintenance period, a healthy, well-rooted, even-colored, viable lawn has been established, free of weeds, open joints, bare areas, and surface irregularities.
- B. Use specified materials to reestablish lawns that do not comply with requirements and continue maintenance until lawns are satisfactory.

3.11 LAWN WARRANTY

- A. Warranty for all seeded and sodded lawns shall be for one (1) year past the date of project Final Completion.

3.12 CLEANUP AND PROTECTION

- A. Promptly remove soil and debris, created by lawn work, from paved areas. Clean wheels of vehicles before leaving site to avoid tracking soil onto roads, walks, or other paved areas.
- B. Erect temporary fencing or barricades and warning signs as required to protect newly planted areas from traffic. Maintain fencing and barricades throughout initial maintenance period and remove after lawn is established.
- C. Remove nondegradable erosion-control measures after grass establishment period.

END OF SECTION 32 92 00