

Article 1 Revision

DWELLING, TWO-FAMILY - A building occupied exclusively for residential purposes by two families or two housekeeping units, commonly known as a duplex. Townhouses are not included in this definition.

This definition also includes a building occupied by five (5) or more unrelated individuals in a unit at any time within five years prior to January 1, 2010, subject to the following:

- (a) the occupancy of each unit is restricted to six (6) or less unrelated individuals;
- (b) the use of the building as rental dwellings has not been abandoned;
- (c) the building shall not be enlarged or expanded beyond the existing square footage as of January 1, 2010:
 - 1. by more than 25% unless the building has been expanded by 25% or more under a building permit issued on or after January 1, 2005, in which case, then by no more than 5%; or
 - 2. unless approved by the Board of Adjustment as a conditional use after January 1, 2010.
- (d) the limitation on enlargement of the building set forth in (c) above shall not apply in the case of the addition of a second unit in a Two-Family (R-2) zone, provided that both units thereafter conform to the limitation of four unrelated persons per dwelling unit.

DWELLING UNIT - One room or rooms connected together, constituting a separate, independent housekeeping establishment for occupancy by a family as owner, by rental or lease on a weekly, monthly or longer basis; physically separated from any other rooms or dwelling units which may be in the same building, and containing independent kitchen and sleeping facilities.

DWELLING UNIT, ACCESSORY (ADU) – A smaller, secondary independent housekeeping establishment located on the same lot as a principal dwelling. ADUs are independently habitable and provide the basic requirements of shelter, heating, cooking, and sanitation. There are two types of ADUs:

- (a) Detached structures. Examples include converted garages or new construction.
- (b) Attached units are connected to or part of the principal dwelling. Examples include converted living space, attached garages, basements or attics; additions; or a combination thereof.

ECOTOURISM – Activities conducted in natural, greenspace, or environmentally sensitive areas that are offered to the public for the purpose of enjoyment, education, and active involvement in the activities of the site. These activities shall safeguard the integrity of a natural feature, habitat or ecosystem.

ELDERLY HOUSING - Multiple family structures containing at least twenty-four (24) units and solely devoted to housing families consisting of two (2) or more persons, of which the head (or his spouse) is sixty-two (62) years of age or over, or is handicapped; and single persons who are sixty-two (62) years of age or over, or are handicapped.

ENGINEER, PROJECT - A person currently licensed to practice engineering in the State of Kentucky and in good standing with the Kentucky Board of Registration for Professional Engineers and Land Surveyors; or a firm in good standing as an Engineering company in Kentucky, if the work is to be accomplished other than as a sole practitioner. Work performed under the supervision or at the direction of the project engineer, including, but not limited to: preparation of plans, inspections, reports, testing, and directives or orders regarding work pursuant to these Subdivision Regulations, shall be considered to be the work of the project engineer. Whenever qualifications are questioned, the Commission will consult with the Bluegrass Chapter of the Kentucky Society of Professional Engineers or the Consulting Engineers Council of Kentucky.

ENGINEER, URBAN COUNTY - The Director of the Lexington-Fayette Urban County Government Division of Engineering.

ENTERTAINMENT, LIVE - Any performance at a restaurant, cocktail lounge, or night club by any person; including, but not limited to, a patron of such establishment if such performance is part of a regularly occurring event. Live entertainment includes, but is not limited to: singing, dancing, musical performance, comedy acts, magic acts, variety acts, or performance contests engaged in by patrons.

ENTRANCE, PRIMARY - Entrance used as the main pedestrian access point of a structure and along the front lot line.

EQUINE HOSPITAL - A veterinary hospital used primarily for the treatment and care of horses, which may include office facilities and the storage

ARTICLE 3

GENERAL ZONE REGULATIONS

3-1 APPLICATION OF ZONE REGULATIONS - The regulations set by this Zoning Ordinance within each zone shall be minimum or maximum limitations, as appropriate to the case, and shall apply uniformly to each class or kind of structure or land, except as hereinafter provided:

- (a) No building, structure, or land shall hereafter be used or occupied; and no building or structure or part thereof shall hereafter be erected, constructed, reconstructed, moved or structurally altered except in conformity with all of the regulations herein specified for the zone in which it is located unless otherwise specifically permitted in this Zoning Ordinance.
- (b) No building or other structure shall hereafter be erected or altered:
 - (1) to exceed the height, bulk or floor area ratio;
 - (2) to accommodate or house a greater number of families;
 - (3) to occupy a greater percentage of lot area;
 - (4) to have narrower or smaller rear yards, front yards, side yards, or other open spaces; or
 - (5) to have less perimeter and interior lot landscaping for vehicular use area and non-compatible land uses than herein required, or in any other manner be contrary to the provisions of this Zoning Ordinance.
- (c) No part of a yard, open space, off-street parking, loading space or other special use area required about or in connection with any building or land, for the purpose of complying with this Zoning Ordinance, shall be included as part of a yard, open space, off-street parking, loading space or other special use area similarly required for any other building or land unless otherwise specifically permitted in this Zoning Ordinance.
- (d) No yard or lot existing at the time of adoption of this Zoning Ordinance shall be reduced in dimension or area below the minimum requirements set forth herein. Yards or lots created after the adoption of this Zoning Ordinance shall meet at least the minimum requirements established by this Zoning Ordinance.
- (e) There shall be no more than one principal structure and its accessory structures on any lot or parcel of land in an agricultural zone or in any residential zone, unless otherwise specifically permitted as a Group Residential Project or a Planned Unit Development in this Zoning Ordinance. In all other zones, more than one principal building shall be permitted only if a development plan is approved by the Commission, as provided by Article 21.
- (f) Only those uses specifically named as principal,

accessory, or conditional uses or substantially similar to principal, accessory or conditional uses are permitted in each zone. All uses not specifically permitted or substantially similar to permitted uses are prohibited. Prohibited uses shall include, but not be limited to, those specifically named as prohibited.

3-2 CONVERSION OF STRUCTURES - The conversion of any structure or structures, either residential or non-residential, so as to accommodate an increased number of dwelling units or families, or another permitted use, shall be permitted only within a zone in which a new building for similar occupancy would be permitted under this Zoning Ordinance. The resulting occupancy shall comply with all requirements governing new construction in such zone, including, but not limited to, floor area; floor area ratios; dimension of yards; open spaces; and off-street parking. The aforesaid requirements with respect to yards shall not apply if the conversion involves no exterior structural changes to a principal building, but shall apply if an accessory building is converted to a principal building.

3-3 SIGHT TRIANGLES FOR TRAFFIC VISIBILITY - Except as permitted herein, in any zone, at any street intersection, railroad crossing, or any driveway intersection, no fence, structure or planting, other than ground cover, shall be erected or installed within the sight distance triangle as shown in the table and the illustrations below.

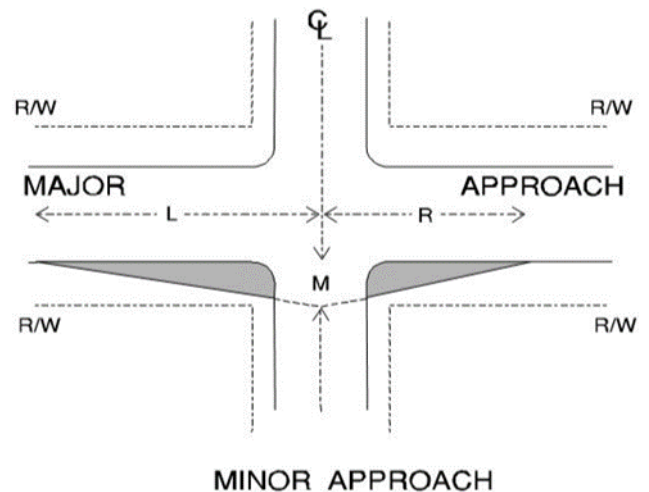

SIGHT TRIANGLES AT INTERSECTIONS *1*2*3

MINOR APPROACH

M
A
J
O
R

A
P
P
R
O
A
C
H

	PUBLIC OR PRIVATE STREET	DRIVEWAY
Major Arterial	L = 325' R = 150' M = 15'	L = 325' R = 150' M = 15'
Minor Arterial	L = 325' R = 150' M = 15'	L = 275' R = 150' M = 15'
Collector	L = 200' R = 150' M = 15'	Non-Residential L = 200' R = 150' M = 15' Residential L = 150' R = 120' M = 15'
Local Street	L = 175' R = 130' M = 15'	L = 75' R = 55' M = 10'

SIGHT TRIANGLES AT RAILROAD CROSSINGS *1*2*3

APPROACH

	PRIVATE OR PUBLIC STREET OR HIGHWAY	ANY TYPE OF PRIVATE DRIVEWAY
Railroad Approach	D = 725' M = 35' L = 8'	D = 325' M = 25' L = 6'
Where D' =	Distance along rail	Distance along rail
Where M' =	Distance from rail	Distance from rail
Where L' =	Distance from edge of pavement	Distance from edge of pavement

- *1 The table assumes right angle intersections and straight major approach movements within the sight distance. Situations involving skewed intersections, curvilinear streets and other mitigating factors shall have sight distances, as determined by the Urban County Traffic Engineer.
- *2 In the B-2, B-2A, and B-2B zones, the sight triangle may be modified at signalized intersections, as determined by the Urban County Traffic Engineer.
- *3 Wire or chain link fences may be located within the sight triangle when approved by the Division of Traffic Engineering and the Division of Building Inspection upon a finding that visibility would not be impaired.

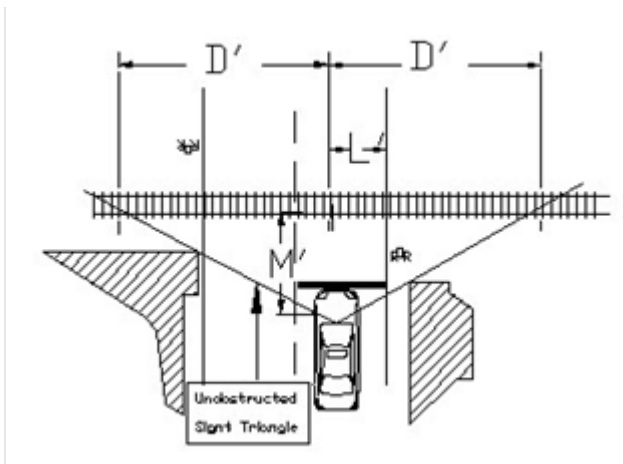

3-4 AGRICULTURAL LAND USE EXEMPTIONS -

Notwithstanding any other provision of this Zoning Ordinance, land which is used solely for agricultural use, as defined herein, shall have no regulations imposed as to building permits, certificates of occupancy, height, yard, or location requirements for agricultural buildings, except that a setback line of thirty feet shall be required for agricultural buildings for the protection of existing and proposed streets and highways; and that all buildings or structures in a designated floodway or floodplain, or which tend to increase flood heights or obstruct the flow of flood waters, may be fully regulated. Any parcel of land used for an urban agricultural use with the Urban Service Area, as defined herein, shall also be exempt from use restrictions listed in each zone, but buildings proposed for such uses shall be subject to building permit, zoning setback, floodplain setback and certificate of occupancy requirements contained herein.

3-5 FALLOUT SHELTERS -

Fallout shelters, as defined by this Ordinance, shall be permitted as principal or accessory uses in all zones subject to applicable yard, height, area, and other regulations for principal or accessory structures for the zone in which such shelter is located.

3-6 MIXED-INCOME HOUSING BONUSES -

Units that are designated as Mixed-Income Housing Units in order to

receive either additional density, parking reductions or additional floor area shall be restricted by the developer exclusively to mixed-income housing for a minimum period of 5 years. Further, such units shall be identified separately in the Certificate of Land Use Restriction filed for the development where the units are located; and such units shall be subject to a deed restriction in favor of the Lexington-Fayette Urban County Government, which shall restrict the use of the property and shall establish monitoring procedures to ensure that the units remain affordable during the period. Affordable housing units within the defined Expansion Area shall be subject to Article 23A(2)(w).

3-7 GENERAL REGULATIONS FOR CEMETERY PROTECTION - Existing private family cemeteries shall be permitted to remain in all zones. Upon the filing of a development plan or subdivision plan, a private family cemetery shall be preserved and protected in its existing location or relocated within Fayette County unless specifically requested by family or other heirs, and shall be regulated as follows:

- (a) Disinterment and relocation of graves shall be accomplished in accordance with all applicable local and state requirements and with the knowledge and approval of the Kentucky Office of Vital Statistics.
- (b) Preservation and protection of a cemetery, either left in place or once relocated, shall be subject to the following requirements:
 - (1) No construction or disturbance of any kind shall occur within fifty (50) feet of a cemetery boundary, regardless of property lines or ownership, except as provided herein (fence, wall, access easement or landscaping).
 - (2) Screening and landscaping shall be provided as stated in Article 18-3(a)(1). If a cemetery is located on a larger tract of property, then screening shall be located adjacent to the cemetery fence inside the 50-foot buffer area.
 - (3) When a cemetery is identified on land proposed for development, the cemetery boundary shall be established based on historic records, fence lines, gravesite locations or other criteria, as determined by a certified archeologist, prior to any construction or disturbance.
 - (4) A cemetery boundary study performed by a certified archeologist shall be submitted with any development plan, preliminary subdivision plan, and minor or major subdivision plat for land with identified cemeteries or burial grounds. Such study shall include a map that portrays the location and orientation of graves within the cemetery and the associated geographic coordinates, and a written description of field and archival methods used to document the cemetery.
 - (5) Any existing cemetery fence, wall and/or gate on the subject property shall be maintained and repaired

prior to any site work or disturbance on any surrounding property. Where none exists, a new permanent fence shall be erected prior to any site work or disturbance on the subject property. Such fence shall be constructed of durable and weather-resistant materials (i.e., brick, stone, iron and/or steel).

- (6) A statement of maintenance and permanent ownership shall be made on any development plan.
- (7) Access shall be provided to the cemetery with a minimum 10-foot-wide access easement.

3-8 GENERAL REGULATIONS FOR VEHICLE REPAIRS ACCESSORY TO A RESIDENTIAL USE - Shall be regulated as follows:

- (a) Vehicles being repaired shall be parked/stored on a paved surface or on a permitted or legally non-conforming gravel surface if a paved surface is not available.
- (b) Major repairs shall be confined to the interior of a garage or other enclosed building, and shall not include any finish painting or clear coating operations.
- (c) At outdoor locations, including any unenclosed structure such as a carport, only minor repairs are allowed. Only one vehicle per dwelling at an outdoor location can be under repair at any given time, and repairs must be completed within three days.
- (d) Repairs are only allowed on vehicles that are registered to an occupant of the dwelling on the subject property.
- (e) Repairs may not be conducted as a business or as part of a commercial operation of any kind.
- (f) All waste oil and fluids shall be recycled or disposed of at an approved off-site location in compliance with local, state and federal environmental regulations. Auto parts and tires shall be recycled or disposed of in accordance with current LFUCG Division of Waste Management guidelines and in compliance with local, state and federal environmental regulations.

3-9 PARKING AND STORAGE OF BUSINESS VEHICLES, TRAILERS, EQUIPMENT AND MATERIALS IN RESIDENTIAL ZONES - Shall be regulated as follows:

- (a) One business vehicle per dwelling is permitted, provided it has no more than two (2) axles and a GVWR (gross vehicle weight rating) of no greater than 14,000 lbs. and is used for daily transportation to and from work. Such a vehicle must be parked on a permitted paved surface or on a legal non-conforming (existed prior to December 5, 2002) gravel surface. Dump trucks, box trucks, cube vans, high-roof cargo vans (greater than 8' height, as measured from ground to top of roof), earth-moving machinery, tow trucks, transport wreckers, semi-trucks and tractor-trailers, concession trucks and vans, and flat-bed trucks are specifically prohibited, even if they technically comply with the above limits.

ZOTA 2019-5 ACCESSORY DWELLING UNITS

- (b) One business trailer per dwelling (open or closed), used
- (c) in conjunction with an allowed business vehicle, may be parked or stored on a permitted paved surface or legal non-conforming gravel surface. Any such trailer is limited to a length of no greater than twelve (12) feet. Concession trailers are specifically excluded from this category of allowable trailers, even if they technically comply with axle and length limitations.
- (d) Trailers, equipment or materials shall not be parked or stored on any public or private street.
- (e) Construction materials (such as siding or brick) and salvaged items (such as used appliances or scrap metal) may not be stored.
- (f) Business activities (e.g., selling of merchandise or customer visits) shall not take place on the premises, except as allowed by home office provisions or as authorized by a conditional use approved by the Board of Adjustment. Corollary business activities, such as the storage of merchandise or having employees report to the property, are also prohibited.

3-10 GENERAL REGULATIONS FOR OPERATION OF A HOME OFFICE OR HOME OCCUPATION - Shall be as follows:

- (a) The use shall be clearly incidental and secondary to use for dwelling purposes, with no more than three hundred (300) square feet of the dwelling devoted to each use;
- (b) The use shall be operated by and shall employ only residents of the dwelling;
- (c) No commodities or merchandise shall be stored on the property other than those produced and/or repaired by the residents on the premises;
- (d) The residence shall maintain its residential character and shall not be altered or remodeled so as to change the residential appearance of the building;
- (e) No outside signage related to the use shall be permitted on the premises;
- (f) The use shall be located in the dwelling unit and not in any accessory building;
- (g) On-site sales or visits to the home by customers, clients, patrons and the general public are not allowed;
- (h) The use does not involve firearms or potentially disturbing equipment, materials or chemicals.

These provisions are not intended to restrict offices accessory to principal permitted agricultural uses located in homes on the same agricultural property.

Home office shall not include offices for escort services.

3-11 GENERAL REGULATIONS FOR OPERATION OF A HOME-BASED BUSINESS - Shall be as follows:

- (a) All activities shall comply with the provisions outlined in 3-10(a) through (f) above;
- (b) Any conditions regarding the use of firearms or potentially disturbing equipment, materials or chemicals (e.g., soundproofing or other safety measures) shall be as

- determined to be appropriate by the Board of Adjustment;
- (c) Limitations on hours of operation and frequency of customer/client visits shall be as determined to be appropriate by the Board of Adjustment;
- (d) No additional paving for parking shall be permitted;
- (e) The use does not adversely affect surrounding properties by excessive traffic generation, noise or odors that might be associated with equipment, materials or chemicals used in the operation of the home-based business.

3-12 GENERAL REGULATIONS FOR ACCESSORY DWELLING UNITS (ADUs) – Shall be as follows:

- (a) Pre-Application Conference – Prior to filing an application for a building permit for an ADU, the applicant shall meet with appropriate staff members of the Division of Planning to discuss the proposed permit. The purpose of this conference is to discuss, at the earliest stages, the requirements, procedures and issues related to the proposed ADU, and to provide guidance for the property owner relative to the Homeowner’s Guide to Accessory Dwelling Units (ADU Manual).

It is intended that this conference will help to alleviate possible conflicts by early recognition of existing conditions, necessary facilities, and the recommendations of the ADU Manual pertaining to design, layout, and other considerations. The applicant shall arrange the conference, which shall be held not less than five (5) working days nor more than three (3) months prior to submitting the application.

The staff shall keep a record of the conference date and include the information in the records of the building permit file. The Division of Planning shall not accept an application for a zoning compliance permit for an ADU for which a pre-application conference has not been held.

- (b) Construction:
An ADU may be created through new construction, alteration of an existing structure, addition to an existing structure, or conversion of an existing structure to an ADU while simultaneously constructing a new primary dwelling unit on the site.

- (c) Number of Units:
One (1) ADU is permitted per single family dwelling per lot.

- (d) Minimum Lot Size:
None.

- (e) Maximum ADU Size:
800 square feet.

For a detached ADU, Article 15-6(c) also applies.

- (f) Maximum Floor Area (FAR) and Lot Coverage:

ZOTA 2019-5 ACCESSORY DWELLING UNITS

For an attached ADU, the maximum FAR and lot coverage shall be that of the underlying zone.

For a detached ADU, Article 15-6(c) shall apply.

(g) Yard requirements:

For an attached ADU, the yard requirements shall be those required for a principal structure in the underlying zone.

For a detached ADU, the ADU shall be located behind the rear wall of the principal residence. Article 15-6 shall also apply.

(h) Maximum Height:

For an attached ADU, the maximum height shall be that of the underlying zone.

For a detached ADU, Article 15-6 shall apply.

(i) Off-Street Parking:

For ADUs located in a zone with a maximum parking requirement, one (1) additional space may be permitted.

(j) Short-Term Rentals (as defined in the Code of Ordinances)

(1) The use of an ADU as a short-term rental shall only be allowed as a conditional use.

(2) If either dwelling unit is used as a short-term rental, as defined in the Code of Ordinances, the property owner is required to occupy one of the dwelling units.

(k) Design Standards

Entrances: Only one (1) pedestrian entrance to the structure may be located on the primary wall plane of the dwelling unit.

Exterior Stairs: Any exterior stairs to serve as the primary entrance to an ADU within the principal structure shall be located on the side or rear of such the primary dwelling.

(l) Alterations of existing structures: If a detached ADU is created from an existing detached accessory structure that does not meet one or more of the standards within Article 3-12, the structure is exempt from the standard(s) it does not meet as per Article 3-2.

However, as per Article 4-4, any alterations that would result in the structure becoming less conforming with those standards it does not meet is not allowed.

(m) Maximum Occupancy Limit – A maximum of two (2) persons and any children related to either of them or under their care through a duly authorized custodial relationship may reside in the ADU.

(n) Owner Occupancy:

The owner of the property must occupy either the principal dwelling unit or the ADU as the owner's permanent residence.

(o) Deed Restriction:

A deed restriction shall be submitted prior to the issuance of a zoning compliance permit which states that the owner(s) agree to restrict use of the principal and ADU in compliance with the requirements of Article 3-12.

At the request of the property owner and after an inspection verifying that the ADU has been removed from the owner's property, LFUCG shall record a release of any previously recorded deed restriction for that ADU.

LFUCG Capacity Assurance Program, documenting that adequate sanitary sewer service is available.

5-2(i) OTHER PERMITS - Additional permits may be required by the responsible Divisions to enforce the provisions of this Ordinance.

5-3 COMPLIANCE WITH OTHER CODES, STATUTES AND REGULATIONS - Nothing in this section or other sections of the Zoning Ordinance shall be construed to exempt any applicant for a permit from compliance with all local, state and federal codes, statutes and regulations.

5-4 PERMIT APPLICATION REQUIREMENTS AND PROCEDURES - All applications for permits shall be accompanied by such plans and information as the responsible Division deems to be necessary to determine compliance and provide for enforcement of this Zoning Ordinance. After reviewing the application materials, the Director of the responsible Division shall mark the application either as "Approved" or "Disapproved" and attest to the same by signature on such copy. The original, similarly marked, shall be retained by the responsible Division.

5-4(a) BUILDING PERMITS FOR SINGLE FAMILY AND TWO-FAMILY DWELLINGS - All applications for permits for detached single family and two-family dwellings and their accessory buildings shall be accompanied by plans showing the location and dimension of any existing or proposed principal or accessory buildings on the lot; the location and dimension of all required yards; height of the building; and the location and dimension of the required parking, as well as any other information deemed necessary by the Division of Building Inspection to determine compliance with this Zoning Ordinance.

5-4(a)(1) DIVISION OF ENGINEERING APPROVAL REQUIRED - The building permit shall not be issued unless and until the Division of Engineering has approved an erosion control plan.

5-4(a)(2) ACCESSORY DWELLING UNITS – The building permit for an accessory dwelling unit shall not be issued unless and until a the Division of Planning has issued a Zoning Compliance Permit.

5-4(b) BUILDING PERMITS FOR ALL OTHER BUILDINGS - All applications for building permits, including associated paving permits, other than those for single family or two-family dwellings and their accessory buildings, shall be accompanied by a site plan, drawn to scale, showing information with regard to the lot and neighboring lots as may be necessary to determine compliance with the Zoning Ordinance and the Code of Ordinances. No building permit application shall be accepted by the Division of Building Inspection until the Division of Planning has approved the site plan, upon finding that the

development proposed thereon complies with all applicable requirements of the Subdivision Regulations and the Zoning Ordinance. The following additional requirements shall be applicable to site plans required under this section:

5-4(b)(1) DIVISION OF ENGINEERING - The building permit shall not be issued unless and until all required information has been submitted to the Division of Engineering as it relates to storm drainage, erosion and sediment control, and sanitary sewers. Off-site improvements may be required if an adequate drainage outfall is not available to the site. The site plan shall include sufficient existing and proposed site elevations to demonstrate that damage to adjacent properties shall not occur, or that an existing off-site problem will not be aggravated. Storm drainage detention on the lot in conformance with the Stormwater Manual will be required, if not provided as a part of the subdivision development.

5-4(b)(2) DIVISION OF TRAFFIC ENGINEERING APPROVAL REQUIRED - The building permit shall not be issued unless and until the Division of Traffic Engineering has approved the site plan as it relates to access point design details and parking lot circulation layout.

5-4(b)(3) OTHER APPROVALS - If this Zoning Ordinance or the Code of Ordinances requires approval by another agency of certain site plan features, such approval shall be obtained prior to issuance of a building permit.

5-4(b)(4) DEVELOPMENT PLAN AS SITE PLAN - In any case, where the Planning Commission has approved a detailed final development plan showing essentially the same information as required above for the property seeking a building permit, no separate site plan shall be required to be prepared. The applicant shall be required to supply such supplementary information as necessary to comply with all requirements of this Section 5-4(b).

5-4(c) MOBILE HOME LOCATION PERMITS - All applications for mobile home location permits shall be accompanied by plans showing the location of the mobile home, as well as any permanent structure on the lot, the location and dimension of all required yards, and the location and dimension of the required parking.

5-4(d) WRECKING PERMITS - Requirements for wrecking permits in Historic Districts shall be as provided in Article 13. Requirements for wrecking permits in all other zones shall be as provided in the Code of Ordinances.

8-5 SINGLE FAMILY RESIDENTIAL (R-1A) ZONE

8-5(a) Intent - These zones are established to provide for single family detached residences and supporting uses. The zones should be located in areas of the community where services and facilities will be adequate to serve the anticipated population. The Comprehensive Plan should be used to determine the location and density (units/acre) of each single family zone.

8-5(b) Principal Uses (Other uses substantially similar to those listed herein shall also be deemed permitted.)

1. Single family detached residences.
2. Parks and playgrounds operated by government.
3. Temporary real estate sales offices for the sale of lots, located only within the subdivision in which said lots are located; to be removed at the end of two years or when all the lots are sold, whichever comes first.

8-5(c) Accessory Uses (Uses and structures which are customarily accessory, clearly incidental and subordinate to permitted uses.)

1. Private garages, storage sheds, and parking areas.
2. Living quarters, without cooking facilities and not rented, for guests and employees of the premises.
3. Swimming pools and tennis courts, including accessory structures and temporary structures associated with those uses.
4. Agricultural uses, excluding commercial stock raising.
5. Private, non-commercial parks and open space.
6. Home offices and home occupations.
7. A ground, roof or pole-mounted satellite dish antenna, as regulated by Article 15-8.
8. Family child care for up to six (6) children, provided that the total number of children living or being cared for on the premises shall not exceed six (6).
9. Hiking and bicycling trails.

10. Accessory Dwelling Units, as regulated in Article 3-12 of the Zoning Ordinance

8-5(d) Conditional Uses (Permitted only with Board of Adjustment approval.)

1. Kindergartens and nursery schools for four (4) and not more than twelve (12) children, when accessory to and located in the same structure with the single family residence occupied by the owner or operator. All kindergartens and

- nursery schools shall provide a fenced and screened play area, which shall contain not less than twenty-five (25) square feet per child.
2. Kindergartens, nursery schools and child care centers for four (4) or more children, when accessory to a place of religious assembly, school or private club as permitted herein. A fenced and screened play area shall be provided, which shall contain not less than twenty-five (25) square feet per child.
3. Home-based businesses.
4. Cemeteries, columbariums, and mausoleums.
5. Outdoor commercial and non-commercial recreational facilities, such as golf courses; sportsmen's farms; riding stables and equine trails; fishing lakes and non-commercial swimming pool; tennis courts; campgrounds; and private clubs.
6. Places of religious assembly.
7. Schools for academic instruction.
8. Mining of non-metallic minerals, but only when the proposal complies with the requirements of the Mining/Quarrying Ordinance (Code of Ordinances #252-91) and the conditions and requirements as set forth therein. The Board of Adjustment shall specifically consider and be able to find:
 - a. That the proposed use will not constitute a public nuisance by creating excessive noise, odor, traffic, dust, or damage to the environment or surrounding properties;
 - b. That a reasonable degree of reclamation and proper drainage control is feasible; and
 - c. That the owner and/or applicant has not had a permit revoked or bond or other security forfeited for failure to comply with any Federal, State or local laws, regulations or conditions, including land reclamation, pertaining to the proposed use.
9. Family child care for seven (7) and not more than twelve (12) children, provided that the total number of children living or being cared for on the premises shall not exceed twelve (12). A fenced outdoor play area shall be provided, which shall contain not less than twenty-five (25) square feet per child.
10. Bed and breakfast facilities, limited to the rental of not more than one (1) room. The Board of Adjustment, in considering approval of such conditional use, shall consider and make a finding that the number of rooms granted shall not have an adverse effect on surrounding properties. In addition, in considering such a conditional use, the Board of Adjustment shall take into consideration the number of bed and breakfast facilities, if any, within the general neighborhood of the property being considered for such use.
11. Historic house museums.
12. Seasonal activities.
13. Market gardens.
14. [The short-term rental \(defined in the Code of Ordinances\) of Accessory Dwelling Units, as regulated in Article 3-12 of the Zoning Ordinance. The Board of Adjustment, in considering approval of such conditional use, shall consider and make a](#)

ZOTA 2019-5 ACCESSORY DWELLING UNITS

finding that the number of rooms granted shall not have an adverse effect on surrounding properties. In addition, in considering such a conditional use, the Board of Adjustment shall take into consideration the number of short-term rental facilities, if any, within the general neighborhood of the property being considered for such use.

8-5(e) Prohibited Uses (All uses, other than those listed as principal, accessory, or conditional uses or substantially similar to principal, accessory, or conditional uses, shall be prohibited. The uses below are provided for illustration purposes and for the purpose of limiting permitted uses, and are not intended to be a total listing of all the uses that are prohibited.)

1. Those uses prohibited in the A-U zone, except as permitted herein.
2. Commercial kennels, equine hospitals, and offices of veterinarians.
3. Any use dependent upon septic tanks or pit privies.
4. The above- or below- ground storage of any flammable material in gaseous form, including compressed natural gas, and the above- or below- ground storage of more than five (5) gallons of gasoline.
5. Ecotourism activities, except as permitted herein.
6. Zoological gardens.

Lot, Yard, and Height Requirements (See Articles 3 and 15 for additional regulations.)

8-5(f) Minimum Lot Size - One acre; or 25,000 square feet for property rezoned to R-1A after July 14, 1994.

8-5(g) Minimum Lot Frontage - 150'; or 125' for property rezoned to R-1A after July 14, 1994.

8-5(h) Minimum Front Yard - 50'; or 40' for property rezoned to R-1A after July 14, 1994.

8-5(i) Minimum Each Side Yard - 25'; or 10' for property rezoned to R-1A after July 14, 1994.

8-5(j) Minimum Rear Yard - 25'.

8-5(k) Minimum Useable Open Space - No limitation.

8-5(l) Maximum Lot Coverage - No limitation.

8-5(m) Maximum Height of Building - 35'.

8-5(n) Off-Street Parking (See Article 16 for additional parking regulations.)

Places of Religious Assembly - One (1) space for each five (5) seats in the main auditorium, with a minimum of five (5) spaces.

Dwelling Units - One (1) space per dwelling unit.

Elementary and Junior High Schools - One (1) space for every fifteen (15) seats in the main auditorium; or one (1) space for every classroom, plus one (1) space for each employee, whichever is greater.

All Other Schools for Academic Instruction - One (1) space for every five (5) seats in the main auditorium; or one (1) space for every five (5) classroom seats, whichever is greater.

Golf Courses - Three (3) spaces for every hole on the main course.

Keeping of Roomers or Boarders - One (1) space for every two (2) roomers or boarders.

Kindergartens, Nursery Schools, Day Nurseries and Child Care Centers - Three (3) spaces for the first twelve (12) children, plus one (1) space for every ten (10) (or fraction thereof) additional children.

Family Child Care for between seven (7) and twelve (12) children - One (1) space in addition to that required for the dwelling.

Private Clubs - One (1) space for every four (4) members.

Non-Commercial Outdoor Recreational Facilities, including Playgrounds; Sportsmen's Farms; and Riding Stables - One (1) space for every four (4) members, with a minimum of five spaces.

Temporary Real Estate Sales Offices - One (1) space for every four hundred (400) square feet of floor area to be used as the sales office.

Conditional Uses - Parking requirements stated herein for conditional uses are minimum requirements; the Board of Adjustment may establish additional requirements, as needed. Where no requirement is stated herein, the Board shall determine the required parking for the conditional use.

Combinations - Combined uses shall provide parking equal to the sum of individual requirements.

8-9 SINGLE FAMILY RESIDENTIAL (R-1E) ZONE

8-9(a) Intent - This zone is intended to provide for single family detached residences on small lots, and at a higher density than would be possible in other detached single family zones. It may be used for zero-lot-line houses and for patio houses. This zone should be at locations and at the density (units/acre) recommended by the Comprehensive Plan and in areas of the community where necessary services and facilities will be adequate to serve the anticipated population.

8-9(b) Principal Uses (Other uses substantially similar to those listed herein shall also be deemed permitted.)

1. Single family detached residences.
2. Parks and playgrounds operated by government.
3. Temporary real estate sales offices for the sale of lots, located only within the subdivision in which said lots are located; to be removed at the end of two years or when all the lots are sold, whichever comes first.

8-9(c) Accessory Uses (Uses and structures which are customarily accessory, clearly incidental and subordinate to permitted uses.)

1. Private garages, storage sheds and parking areas.
2. Swimming pools and tennis courts.
3. Agricultural uses, excluding commercial stock raising.
4. Private, non-commercial parks and open space.
5. Home offices and home occupations.
6. A ground, roof or pole-mounted satellite dish antenna, as regulated by Article 15-8.
7. Family child care for up to six (6) children, provided that the total number of children living or being cared for on the premises shall not exceed six (6).
8. Hiking and bicycling trails.
9. Accessory Dwelling Units, as regulated in Article 3-12 of the Zoning Ordinance

8-9(d) Conditional Uses (Permitted only with Board of Adjustment approval.)

1. As for R-1A.

8-9(e) Prohibited Uses (All uses other than those listed as principal, accessory, or conditional uses or substantially similar to principal, accessory, or conditional uses shall be prohibited. The uses below are provided for illustration purposes and for the purpose of limiting permitted uses, and are not

intended to be a total listing of all the uses that are prohibited.)

1. As for R-1A.

Lot, Yard, and Height Requirements (See Articles 3, 8-9(o) below, and 15 for additional regulations.)

8-9(f) Lot Size - 4,000 square feet minimum, with a maximum of 7,500 square feet for single family detached uses on lots not fronting upon a cul-de-sac or more than one public street; for all other uses and lots, there shall be no maximum lot size.

8-9(g) Minimum Lot Frontage - 40'.

8-9(h) Minimum Front Yard - 20'.

8-9(i) Minimum Each Side Yard - 3'. No wall, air-conditioning unit, structure or other obstruction shall be located within the required side yard. Any fence located in a required side yard must be entirely to the rear of the principal structure on the lot. (See Article 8-9(o)1 below.)

8-9(j) Minimum Rear Yard - 10'.

8-9(k) Minimum Useable Open Space - No limitation.

8-9(l) Maximum Lot Coverage - No limitation.

8-9(m) Maximum Height of Building - 35'.

8-9(n) Off-Street Parking (See Article 16 for additional parking regulations.)

One space per dwelling unit.

8-9(o) Special Provisions

1. There shall be not less than six (6) feet at any point between the walls of each single family residence.
2. Lot, yard and height requirements for single family detached dwellings in defined Infill and Redevelopment areas are for existing lots as of December 5, 2002, and shall be as follows:
 - a. Where existing lot frontage is 24 feet but less than 40 feet, the provisions of Article 15-7 and the following shall apply:
 1. Minimum lot frontage - 24 feet.
 2. Minimum front yard - As per Article 8-9(h), unless the average depth of the existing front yards on each of the adjacent lots on either side of the lot are less; then the minimum shall be no less than this average, or eight (8) feet, whichever is greater.
 3. Maximum front yard - 40 feet, unless the average depth of the existing front yards on each of the adjacent lots on either side of the lot are greater; then the maximum shall be no

8-10 TOWNHOUSE RESIDENTIAL (R-1T) ZONE

8-10(a) Intent - This zone is intended to provide for attached single family dwellings and supporting uses. This zone should be at locations and at the density (units/acre) recommended by the Comprehensive Plan and in areas of the community where necessary services and facilities will be adequate to serve the anticipated population.

8-10(b) Principal Uses (Other uses substantially similar to those listed herein shall also be deemed permitted.)

1. Single family attached residences, except that not more than twelve (12) units shall be attached.
2. Group Residential Projects, as provided in Article 9.
3. Existing single family detached residences and single family detached residences for which a building permit was issued or a plan approved prior to the adoption of this Zoning Ordinance.
4. Parks and playgrounds operated by government.
5. Temporary real estate sales offices for the sale of lots, located only within the subdivision in which said lots are located; to be removed at the end of two years or when all the lots are sold, whichever comes first.

8-10(c) Accessory Uses (Uses and structures which are customarily accessory, clearly incidental and subordinate to permitted uses.)

1. Private garages, storage sheds and parking areas.
2. Swimming pools and tennis courts.
3. Agricultural uses, excluding commercial stock raising.
4. Private, non-commercial parks and open space.
5. Home offices and home occupations.
6. A ground, roof or pole-mounted satellite dish antenna, as regulated in Article 15-8.
7. Family child care for up to six (6) children, provided that the total number of children living or being cared for on the premises shall not exceed six (6).
8. Hiking and bicycling trails.

9. Accessory Dwelling Units, as regulated in Article 3-12 of the Zoning Ordinance

8-10(d) Conditional Uses (Permitted only with Board of Adjustment approval.)

1. As for R-1A.

8-10(e) Prohibited Uses (All uses other than those

listed as principal, accessory, or conditional uses or substantially similar to principal, accessory, or conditional uses shall be prohibited. The uses below are provided for illustration purposes and for the purpose of limiting permitted uses, and are not intended to be a total listing of all the uses that are prohibited.)

1. As for R-1A, except for townhouses.

Lot, Yard, and Height Requirements (See Articles 3, 8-10(o) below, and 15 for additional regulations.)

8-10(f) Minimum Lot Size - 1,500 square feet.

8-10(g) Minimum Lot Frontage - 15'.

8-10(h) Minimum Front Yard - 10' (See 8-10(o) below).

8-10(i) Minimum Each Side Yard (See 8-10(o) below).

8-10(j) Minimum Rear Yard - 10'.

8-10(k) Minimum Useable Open Space (See 8-10(o) below).

8-10(l) Maximum Lot Coverage - No limitation.

8-10(m) Maximum Height of Building - 35'.

8-10(n) Off-Street Parking (See Article 16 for additional parking regulations.)

As for R-1A.

8-10(o) Special Provisions

1. No more than three (3) contiguous townhouse units may be established at the same setback. A variation of at least three (3) feet shall be required where a break in setback occurs. Buildings may penetrate up to eighteen (18) inches over the building line into the required front yard, but the average setback of the contiguous units shall be at least as great as the required front yard.
2. Required side yard shall be six (6) feet for each side yard of townhouses when no units or only one unit fronts on a side yard; and a side yard of twenty (20) feet when more than one unit fronts on that side yard.
3. Not less than ten percent (10%) of the total lot area for any townhouse shall be devoted to private usable open space either on each lot or on land adjacent and directly accessible to each lot. Such open space shall be for the private use of the residents of each individual townhouse and shall be physically separated from other private open space or common open space by plantings, fences, or walls. The least dimension of the private open space shall be eight (8) feet.
4. In addition to the special provisions listed above, the lot, yard and height requirements for attached single

8-12 PLANNED NEIGHBORHOOD RESIDENTIAL (R-3) ZONE

8-12(a) Intent - This zone is primarily for multi-family dwellings and other residential uses. This zone should be at locations and at the density (units/acre) recommended by the Comprehensive Plan, and in areas of the community where necessary services and facilities will be adequate to serve the anticipated population.

8-12(b) Principal Uses (Other uses substantially similar to those listed herein shall also be deemed permitted.)

1. The principal permitted uses in the R-2 zone.
2. Multi-family dwellings.
3. Dormitories.
4. Boarding or lodging houses, assisted living facilities, and hospitality houses for up to eight (8) persons.
5. Community residences.
6. Group Residential Projects, as provided by Article 9.
7. Townhouses, except that no less than three (3) and no more than twelve (12) units shall be attached.

8-12(c) Accessory Uses (Uses and structures which are customarily accessory, clearly incidental and subordinate to permitted uses.)

1. Items 1 through 3 and 6 through ~~9~~¹⁰ of the permitted accessory uses in the R-1A zone.
2. The keeping of not more than four (4) roomers or boarders per dwelling unit by a resident family for single family or two-family dwellings, except where a bed and breakfast facility is provided; then no roomers or boarders shall be permitted.
3. Non-commercial athletic club facilities, when accessory to another permitted or conditional use.

8-12(d) Conditional Uses (Permitted only with Board of Adjustment approval.)

1. The permitted conditional uses in the R-1A zone.
2. Hospitals, nursing homes, personal care facilities, and orphanages.
3. Community centers (such as YMCA, YWCA, etc.)
4. Community garages.
5. Kindergartens, nursery schools, and child care centers for four (4) or more children. A fenced and screened play area shall be provided, which shall contain not less than twenty-five (25) square feet per child.
6. Parking, as permitted in Article 16-3.

7. Sorority and fraternity houses.
8. Boarding or lodging houses, assisted living facilities, and hospitality houses for more than eight (8) persons and rehabilitation homes, provided that no use permitted under this section shall be located less than five hundred (500) feet, as measured from the nearest property line, from another use permitted under this section. However, the Board may reduce the 500-foot spacing requirement if it can determine that a reduction will not have an adverse influence on existing or future development of the subject property or its surrounding neighborhood.
9. Bed and breakfast facilities, limited to the rental of not more than five (5) rooms. The Board of Adjustment, in considering approval of such conditional use, shall consider and make a finding that the number of rooms granted shall not have an adverse effect on surrounding properties. In addition, in considering such a conditional use, the Board of Adjustment shall take into consideration the number of bed and breakfast facilities, if any, within the general neighborhood of the property being considered for such use.
10. Day Shelters.

8-12(e) Prohibited Uses (All uses other than those listed as principal, accessory, or conditional uses or substantially similar to principal, accessory, or conditional uses shall be prohibited. The uses below are provided for illustration purposes and for the purpose of limiting permitted uses, and are not intended to be a total listing of all the uses that are prohibited.)

1. The prohibited uses in the R-1A zone, except for multi-family, two-family and townhouse dwellings; boarding or lodging houses; dormitories; and sorority and fraternity houses.

Lot, Yard, and Height Requirements (See Articles 3, 8-12(o) below, and 15 for additional regulations.)

8-12(f) Minimum Lot Size - 6,000 square feet.

8-12(g) Minimum Lot Frontage - 50'.

8-12(h) Minimum Front Yard - 20'.

8-12(i) Minimum Each Side Yard - 5', unless required to be a minimum of 30 feet by Article 15-2(b)(3).

8-12(j) Minimum Rear Yard - 10'.

8-12(k) Minimum Usable Open Space - 20%.

8-12(l) Maximum Lot Coverage - 25% and a floor area ratio of 0.5.

8-12(m) Maximum Height of Building - 35'.

8-12(n) Off-Street Parking (See Article 16 for additional

APPENDIX 22B

LUIGART PLANNED UNIT DEVELOPMENT (PUD-2) ZONE

22B-1 INTENT - The intent of the Luigart Planned Unit Development (PUD-2) is to:

1. Implement the recommendations of the 2009 Central Sector Small Area Plan and the 2011 North Limestone Sustainability Plan.
2. Promote the innovative reuse and redevelopment of an older, mixed-use neighborhood in the urban core of Lexington-Fayette County, which is consistent with the Goals and Objectives of the Comprehensive Plan.

This Planned Unit Development zone is established to support infill and redevelopment that maintains neighborhood character, preserves housing affordability and strengthens opportunities for new applied arts and skilled crafts businesses and jobs, which are vital to the 21st century economy of Lexington-Fayette County. Live/Work districts such as this Planned Unit Development zone provide a desirable housing option to creative professionals and a benefit to the surrounding community when located so as to be compatible with existing uses. The Planned Unit Development-2 (PUD-2) is hereby created to accompany lands located between North Limestone Street (to the west), Maple Street (to the east), the R.J. Corman Rail Line (to the north) and West Seventh Street (to the south); and the regulations hereunder shall be established in addition to the applicable regulations contained in this Zoning Ordinance. Where there are conflicts between the regulations hereunder, and those contained elsewhere in the Zoning Ordinance, the use, dimensions and other requirements hereunder shall apply.

22B-2 RELATIONSHIP TO THE COMPREHENSIVE PLAN - This PUD-2 zone is based upon furthering the goals, objectives and land use policies of the 2013 Comprehensive Plan for the Lexington-Fayette Urban County Government (including the 2009 Central Sector Small Area Plan) and the 2011 North Limestone Sustainability Plan.

22B-3 DEFINITIONS - As used in this Article, the following terms shall have the meaning given herein; otherwise, definitions of Article 1 shall apply:

1. Live/Work Space - A dwelling unit that is also used for non-residential uses permitted herein such as, but not limited to: the production, showing and sale of art; both visual and performing arts; office uses and related uses.
2. Artist Studio - A studio working in all art forms, including, but not limited to: painters; sculptors; authors; screenwriters; playwrights; filmmakers; dancers; potters; weavers; jewelers; exhibitors; printers; costumers; musicians and photographers.
3. Artisan Food and Beverage Production - On-site production of food and beverage products, involving

small batch processing. Typical uses include, but are not limited to: coffee roasting; ice cream; baker, candy and other foodstuffs; and alcoholic beverage manufacturing. This may include on-site sales and consumption.

4. Artisan Manufacturing - On-site production of goods by hand manufacturing, involving the use of hand tools and small-scale, light mechanical equipment. Typical uses include, but are not limited to: wood working; ceramic studios; jewelry manufacturing; and uses that have no negative external impacts on surrounding properties. Welding is also permitted.
5. Digital Makerspace - A facility for digital design and fabrication utilizing hardware and software tools.
6. Urban Agriculture - The production and distribution, including on-site sales, in an urban neighborhood of agricultural or horticultural crops, including, but not limited to: poultry; poultry products; grain; hay; pastures; soybeans; timber; orchard fruits; vegetables; flowers or ornamental plants. This use does not include livestock or livestock products.
7. Visiting Artist Housing - A dwelling unit or living quarters made available for visiting artists that may be rented or occupied for less than one week at a time. A maximum of one such housing unit shall be permitted per lot.

~~8. Accessory Dwelling Unit (ADU) - A separate and complete dwelling unit that is contained on the same lot as the structure of a single family dwelling or business. Such a dwelling unit shall be clearly incidental and subordinate to the principal use of the lot.~~

22B-4 MINIMUM SITE LOCATION - Application for a map amendment request to a PUD-2 zone shall be made only on property that meets the following criteria:

22B-4(a) LOCATION - The property must be entirely or substantially located within an area between North Limestone Street (to the west), Maple Street (to the east), the R.J. Corman Rail Line (to the north) and West Seventh Street (to the south).

22B-5 PERMITTED USES - The following uses shall be permitted in the PUD-2 zone. All uses other than those specifically listed as permitted uses or substantially similar to the permitted uses shall be prohibited.

22B-5(a) PRINCIPAL PERMITTED USES

1. Live/Work space.
2. Dwelling units.
3. Artist studios.
4. Artisan food and beverage production.
5. Artisan manufacturing.
6. Digital makerspace.

Article 23 Revision

(d) All terms used herein shall have the same meaning as in the Lexington-Fayette Urban County Comprehensive Plan, the other provisions of the Lexington-Fayette Urban County Zoning Ordinance, and the Lexington-Fayette Urban County Land Subdivision Regulations unless otherwise indicated. The following words and phrases are defined for the purposes of this Article (and when used in the Article shall have the defined meaning regardless of whether the term is capitalized in the text):

~~ACCESSORY DWELLING UNIT - A residential dwelling unit of no more than 700 square feet which is incidental and subordinate to a principal single family attached or detached residential unit of at least 1,600 square feet on the property. Accessory dwelling units shall be permitted to be located within an otherwise permitted accessory structure (subject to any size limitations for such accessory structure) or contained within the principal structure.~~

ACREAGE, GROSS - The total number of acres within a parcel including land to the centerline of any adjoining right-of way.

ACREAGE, NET DEVELOPABLE - The total number of acres within a parcel proposed for development less the area that is designated as a greenway, or is a public right-of-way, steep slope over 30%, water body, floodplain, sinkhole or sinkhole cluster area or woodlands.

AFFIDAVIT OF DENSITY TRANSFER RIGHTS (DTR) - An affidavit of Density Transfer Rights (DTR) is a sworn, written statement by a property owner which attests that: 1) the property owner owns or has an option to purchase DTR, and 2) that the DTR have not previously been used on the parcel of land from which the Rights have been transferred or on any other parcel of land. For the purposes of this Section, an option to acquire a DTR which is specifically enforceable shall constitute ownership. An Affidavit of DTR shall be in conformance with a form provided by the Division of Planning.

AFFORDABLE HOUSING UNIT - A dwelling unit which is provided for sale to an owner-occupant household with an income which does not exceed 80% of median income (adjusted for family size) for Lexington-Fayette County, or for rent to a household with an income which does not exceed 60% of the median income (adjusted for family size) for Lexington-Fayette County. For the purposes of this Article, a unit shall be deemed affordable to an owner-occupant if the total principal,

interest, taxes and insurance does not exceed 36% of the household's income; and a unit shall be deemed affordable to a renter household if the total rent, including any tenant-paid utilities, does not exceed 30% of the household's income.

CERTIFICATE OF DENSITY TRANSFER RIGHTS (DTR) - A Certificate of DTR is a document which is issued by the Lexington-Fayette Urban County Government which attests to the existence of DTR which may be transferred to a particular Receiver Site. The certificate constitutes an official determination by Lexington-Fayette Urban County Government that particular DTR are eligible for transfer to a specific Receiver Site, subject to approval of a development plan. The Certificate is not an opinion of title by the Lexington-Fayette Urban County Government in regard to the DTR which are proposed to be transferred.

DENSITY TRANSFER RIGHT (DTR) - A residential density development right which is severable from the real property to which it is appurtenant and which is transferable to another parcel within a specific expansion area.

DIRECT VEHICULAR ACCESS - A driveway which allows a motorized vehicle to move from a residential lot on to a public or private way.

EXPANSION AREAS - The land area of Lexington-Fayette County added to the Urban Service Area under the provisions of the adopted Expansion Area Master Plan and more specifically designated as EA-1, EA-2A, EA-2B, EA-2C and EA-3; as applied to density transfers and exactions as set forth herein, each of the five designated Expansion Areas shall be considered distinct and separate.

EXPANSION AREA MASTER PLAN (EAMP) - An element of the Lexington-Fayette Urban County Government's Comprehensive Plan adopted by the Planning Commission on July 18, 1996, including any duly approved subsequent amendment. As used in this Article, the term shall also be construed to extend to any other Comprehensive Plan element expressly and directly applicable to the Expansion Areas.

FENCE, STONE - A fence either built of quarried or dressed rocks; or from rocks which have been gathered from fields or creek bottoms; or of undressed ledge or quarried rock.

23A-5 EXPANSION AREA RESIDENTIAL 1 (EAR-1) ZONE

23A-5(a) INTENT - This zone is intended to provide a mixture of low density residential uses which will serve as a transition between the more intensely developed suburban neighborhoods and the Rural Service Area.

23A-5(b) PRINCIPAL USES

1. Single family, two-family, multi-family, and town-house dwellings.
2. Community Residences.
3. Golf Courses and common open spaces.
4. Places of religious assembly when located adjacent to a street that has the functional classification of collector/boulevard or arterial.

23A-5(c) ACCESSORY USES

1. Private garages and parking areas.
2. ~~Accessory dwellings, as defined herein.~~ Accessory Dwelling Units, as regulated in Article 3-12.
3. Swimming pools and tennis courts, which may include a clubhouse, as approved by the Planning Commission on a final development plan, for the use and enjoyment of the surrounding neighborhood, which may also include weight training and exercise rooms, restrooms, meeting rooms, or similar facilities.
4. Home offices and home occupations.
5. Family child care for up to six children.
6. The keeping of not more than two roomers or boarders by a resident family.
7. Child care facilities and schools for academic instruction when accessory to a place of religious assembly on the same property.
8. Non-commercial hiking and bicycling trails.

23A-5(d) CONDITIONAL USES

1. Home-based businesses.
2. Family Child care for seven and not more than 12 children, provided the total number of children living or being cared for on the premises shall not exceed twelve.
3. Temporary Real Estate Sales Offices for the sale of lots located only within the subdivision in which the sales office is located, to be removed at the end of two years or when all the lots are sold, whichever comes first.
4. Clubhouse, with sale of food and merchandise, when accessory to a golf course.

5. Historic house museums.
6. Schools for academic instruction, except as permitted herein, but only when located on a lot adjacent to a street that has the functional classification of collector/boulevard or arterial.
7. Equine trails.
8. Seasonal activities.
9. Market gardens.
10. The short-term rental (defined in the Code of Ordinances) of Accessory Dwelling Units, as regulated in Article 3-12 of the Zoning Ordinance. The Board of Adjustment, in considering approval of such conditional use, shall consider and make a finding that the number of rooms granted shall not have an adverse effect on surrounding properties. In addition, in considering such a conditional use, the Board of Adjustment shall take into consideration the number of short-term rental facilities, if any, within the general neighborhood of the property being considered for such use.

23A-5(e) PROHIBITED USES - All uses not specifically listed as permitted shall be prohibited.

LOT, YARD, HEIGHT AND DENSITY REQUIREMENTS

23A-5(f) DWELLING UNIT DENSITY - The dwelling unit density within the EAR-1 zone shall not exceed three (3) units per gross acre. (See Special Provisions below)

23A-5(g) MAXIMUM HEIGHT OF BUILDING - 35 feet.

23A-5(h) FLOOR AREA RATIO - None; except where more than one principal residential structure is placed on a lot, the FAR shall not exceed 0.5.

23A-5(i) OFF-STREET PARKING REQUIREMENTS

1. There shall be a minimum of one space per dwelling unit for single family detached, duplex and townhouse residential units. Multi-family units shall have a minimum of 1.5 spaces per unit; except for elderly housing, which shall provide three (3) spaces for every four (4) units. One additional space shall be provided for any accessory dwelling unit.
2. Golf Courses - As per CD.