



April 24, 2019

SUBMITTAL

PROJECT NAME

**INVITATION TO BID #43-2019 PLUG VALVE 20 INCH AND KNIFE GATE VALVE
20 INCH FOR WEST HICKMAN WWTP**

PURCHASE ORDER

VALVE TYPE

DeZURIK 100% Area Rectangular Port Eccentric Plug Valve (AWWA C517) (PEF)
Cast Knife Gate Valve (KGC)

CONTRACTOR:

USA

LOCAL SUPPLIER:

RAWDON MYERS, INC.

MANUFACTURER:

DeZURIK
250 RIVERSIDE AVE NORTH
SARTELL, MN 56377
(320) 259-2000

Quote Number:

133046



TABLE OF CONTENTS

A Data Sheet is included for each line item on the purchase order.
Document numbers are listed at the bottom of the Data Sheet.
Any one drawing may apply to more than one item number.
All documents are assembled in alpha/numeric order within each section

- DATA SHEETS
- INSTALLATION DRAWINGS
- CROSS SECTION DRAWINGS
- RECOMMENDED SPARE PARTS
- MATERIALS OF CONSTRUCTION
- LONG & SHORT TERM STORAGE FORM



Submittal Data Sheet

Date: 01/22/2019

USA

QUOTE NUMBER 133046
REV

PROJ. West Hickman WWTP DeZurik Valve
Replacement

Fact. ITEM	Cust. ITEM	QTY	DESCRIPTION
1	1	1	PEF,20,F1,CI,NBR,CR*GS-12A-HD24
Style		PEF	DeZURIK 100% Area Rectangular Port Eccentric Plug Valve (AWWA C517)
Size		20	20 Inch (500mm), Type 316 Stainless Steel Bearings - ASTM A743 Grade CF8M, Welded-In Nickel Seat
End Connection		F1	Flanged, Drilled to ASME B16.1 Class 125/150
Body Material		CI	Cast Iron, ASTM A126, Class B
Packing		NBR	Acrylonitrile-Butadiene Reinforced, Multiple V-Ring with External Adjustment, -20 to 180 Degree F. (-29 to 83 Degree C.)
Plug Facing		CR	Ductile Iron - ASTM A536 with Chloroprene Face; -20 to 180 °F (-29 to 83 °C)
Coating or Paint		4G0	3 mils minimum (non-stainless steel parts) of Blue DeZURIK Enamel on Exterior and Standard (SP10) surface prep
Actuator Type		GS-12A-HD24	G-Series Worm Gear with Handwheel Operator

RELATED DOCUMENTS

A055446	DWG INST PEF F GS-12A-HD 10-20"
A055403	DWG VALVE ASSY PEF F1 3-20"
A055615	DWG ACT GS/GB-6A/12A-HD/CW/N
A055418	DWG CONN PARTS GS/GB-6A/12A PEF
D010453	IM VALVE PEF 3-36"
D010456	IM ACT G-SERIES MANUAL FULL PORT ECCENTRIC

FEATURES

Tag: 1



Submittal Data Sheet

Date: 01/22/2019

USA

QUOTE NUMBER 133046
REV

PROJ. West Hickman WWTP DeZurik Valve
Replacement

Fact. ITEM	Cust. ITEM	QTY	DESCRIPTION
2	2	1	KGC,20,ES,F1,S1,SMP,S1-M*MN-HD20-CS
Style		KGC	Cast Knife Gate Valve
Size		20	20 Inch (500mm)
Body Style		ES	Extended Service Valve
End Connection		F1	Flanged Drilling; ASME Class 150
Body Material		S1	304 Stainless Steel Cast
Packing		SMP	PTFE Braided Packing to 500° F. (260° C.); (pH Range 0-14)
Gate Material		S1	304 Stainless Steel
Seat Material		M	Metal
Coating or Paint		4G0	3 mils minimum (non-stainless steel parts) of Blue DeZURIK Enamel on Exterior and Standard (SP10) surface prep
Actuator Type		MN-HD20-CS	Handwheel; 20 In Dia; Carbon Steel Yoke

RELATED DOCUMENTS

A059095	DWG INST KGC ES MN-HD20 14-24"
A046357	DWG VALVE ASSY 2-24" 150 FL KGV
A047224	DWG ACT HDWHL/CHWHL KGC 14-36"
D010411	IM VALVE KGC ES/HD 2-24
D010079	IM ACT MANUAL C&L GV

FEATURES

Tag: 2

VALVE SIZE		DIMENSIONS <small>INCHES MILLIMETERS</small>										
INCH	MM	A	B	C	D	E	F	G	H	J	K	L
8	200	1.23 31	11.50 292	7.65 194	11.75 296	3/4-10 UNC	4	.75 19	.88 22	4	13.47 342	16.22 412
10	250	1.30 33	13.00 330	9.19 233	14.25 362	7/8 - 9 UNC	8	.86 17	1.00 25	4	14.88 378	16.88 429
12	300	1.36 35	14.00 356	11.53 293	17.00 432	7/8 - 9 UNC	8	.75 19	1.00 25	4	16.94 430	18.94 481
14	350	1.50 38	17.00 432	12.06 306	18.75 476	1 - 8 UNC	8	.88 22	1.13 29	4	18.25 464	20.25 514
16	400	1.55 39	17.75 451	14.13 359	21.25 540	1 - 8 UNC	8	.88 22	1.13 29	8	19.69 500	21.69 551
18	450	1.68 43	21.50 546	15.44 392	22.75 578	1 1/8-7 UNC	12	1.13 29	1.25 32	4	20.94 532	22.94 583
20	500	1.76 45	23.50 597	16.81 427	25.00 635	1 1/8-7 UNC	16	1.13 29	1.25 32	4	22.75 578	24.75 629

VALVE SIZE	ACTUATOR NUMBER	DIMENSIONS <small>IN MM</small>	
		R	S
8-12	GS-12A-HD12	12.00 305	15.12 384
	GS-12A-HD18	18.00 406	15.48 393
10&12	GS-12A-HD12	12.00 305	15.12 384
	GS-12A-HD20	20.00 508	15.48 393
14-20	GS-12A-HD12	12.00 305	18.12 460
	GS-12A-HD18	18.00 406	18.50 470
	GS-12A-HD20	20.00 508	18.50 470
	GS-12A-HD24	24.00 610	22.19 564
	GS-12A-HD30	30.00 762	23.69 602

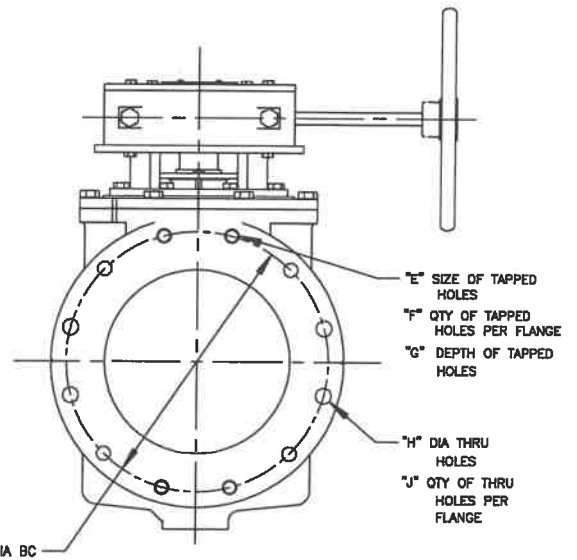
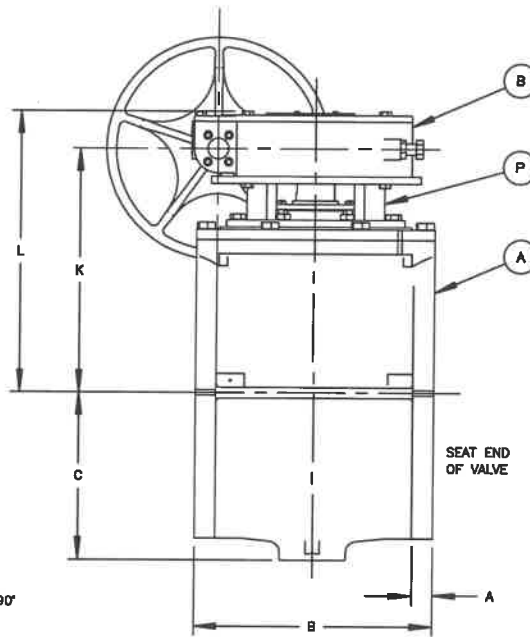
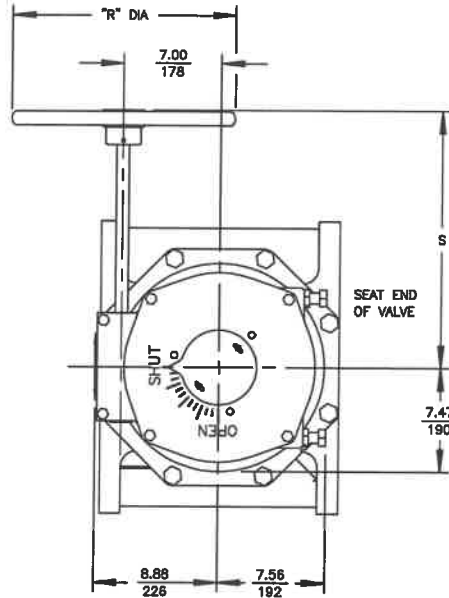

A	VALVE
B	ACTUATOR
P	CONNECTING PARTS

NOTE:

- FLANGES ARE FLAT FACED WITH THICKNESS, DIAMETER AND DRILLING TO CLASS 125 ASME STANDARD B16.1, EXCEPT FOR TAPPED HOLES AS INDICATED. SEE A55487 FOR NON-ASME FLANGE DATA.
- 19 TURNS OF HANDWHEEL ARE REQUIRED TO OPEN VALVE.
- INSTALLATION NOTE:
 - FOR LIQUIDS & GASES: INSTALL VALVE WITH HIGHER PRESSURE AGAINST END OPPOSITE SEAT.
 - FOR SUSPENDED SOLIDS, SLURRIES, ETC: INSTALL VALVE WITH HIGHER PRESSURE AGAINST SEAT END. IN HORIZONTAL PIPELINES, VALVE SHOULD BE INSTALLED ON IT'S SIDE SO PLUG ROTATES TO THE TOP OF THE PIPELINE WHEN OPEN. (SEE DIAGRAM BELOW).
- HD24 AND HD30 HANDWHEELS ARE NOT AVAILABLE IN 90° AND 270° MOUNTING POSITIONS.

NOTICE
THIS DRAWING DOES NOT SHOW ACTUATOR ACCESSORIES. IF ACCESSORIES ARE REQUIRED, REFER TO THE APPROPRIATE ACCESSORY INSTALLATION DRAWING FOR DIMENSIONS AND OTHER RELATED INFORMATION.

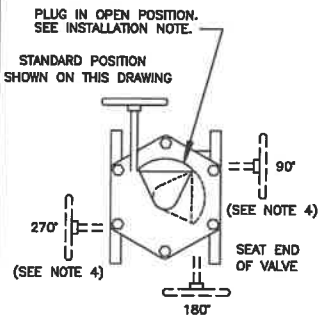

ACTUATOR MOUNTING POSITIONS AS VIEWED FROM TOP OF VALVE. DOTTED LINES SHOW OPTIONAL MOUNTING POSITIONS.

Q	L	E	D	C	B	A
					88272	56/04/17
					81463	01/14/07

DeZURIK
AFCO | HILTON
www.dezurik.com

PEF 100% PORT ECCENTRIC VALVES SIZE 8 - 20 FLANGED
GS-12A-HD_ HANDWHEEL ACTUATED

DOCT. CODE	DRAWN	SN	APPROVED	SN
C1	CHECKED	SN	DATE	10/27/05

A55446

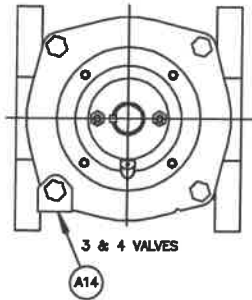

3 & 4 VALVES

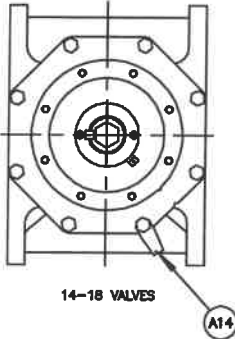

14-18 VALVES

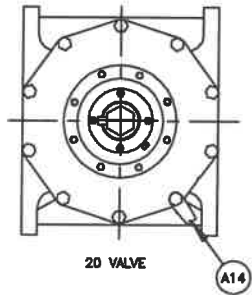

20 VALVE

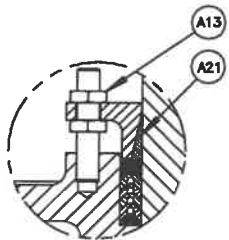

DETAIL "A"
3-8" VALVES
W/NT NUT ACTUATOR

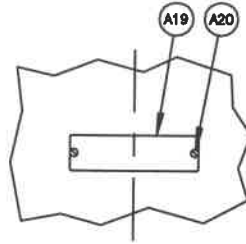

VIEW B - B

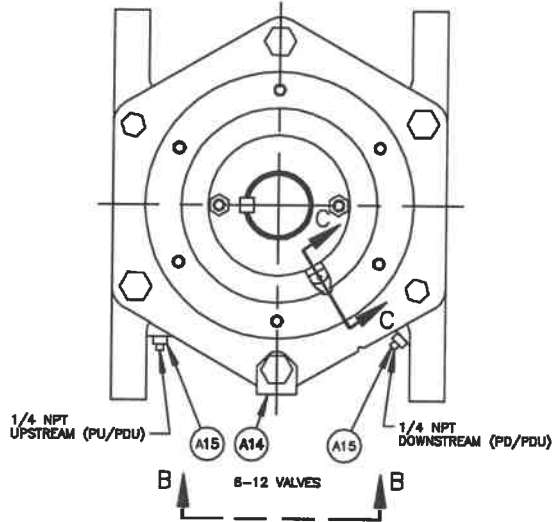

1/4 NPT
UPSTREAM (PU/PDU)

1/4 NPT
DOWNSTREAM (PD/PDU)

6-12 VALVES

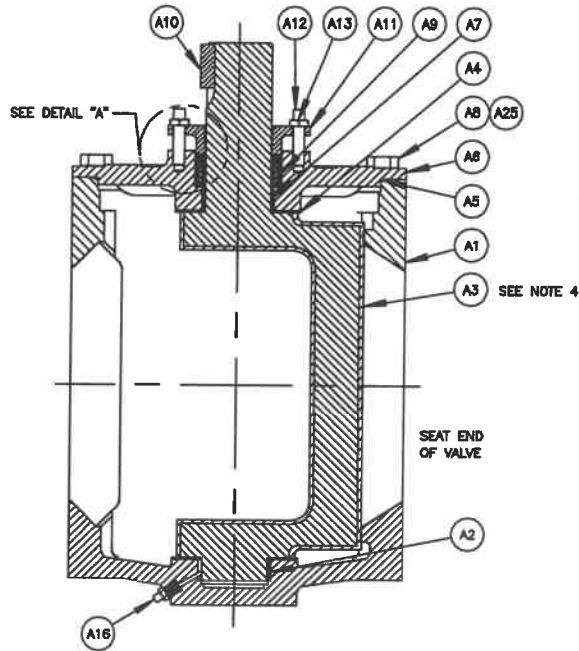

SEE NOTE 4

SEAT END
OF VALVE

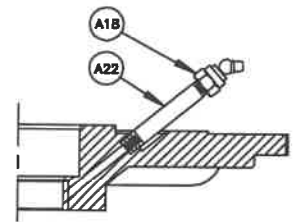

SECTION C-C
GR OPTION-GREASE FITTING IN BONNET,
ALL ACTUATORS

NO	PART NAME	QTY
A1	BODY	1
A2	BEARING (BODY)	1
A3	PLUG	1
A4	GRIT EXCLUDER	2
A5	O-RING	1
A6	BONNET	1
A7	BEARING (BONNET)	1
AB	SCREW (3 & 4 VALVES)	4
AB	SCREW (5 - 12 VALVES)	6
AB	SCREW (14 & 18 VALVES)	8
AB	SCREW (20 VALVE)	10
A9	PACKING	-
A10	KEY (EXCEPT NT)	1
A11	GLAND	1
A12	STUD	2
A13	NUT (EXCEPT NT)	2
A13	NUT (NT)	4
A14	WARNING TAG	1
A15	PIPE PLUG (PU, PD OR PDU)	-
A16	GREASE FITTING (GR)	1
A17		
A18	GREASE FITTING (GR - WHEN REQUIRED)	1
A19	DATA PLATE	1
A20	DRIVE SCREW	2
A21	FRICITION CONE (NT)	1
A22	NIPPLE (GR - WHEN REQUIRED)	1
A25	WASHER (FUSION COATING) (3 & 4 VALVES)	4
A25	WASHER (FUSION COATING) (5-12 VALVES)	6
A25	WASHER (FUSION COATING) (14-18 VALVES)	8
A25	WASHER (FUSION COATING) (20 VALVES)	10

NOTE:

1. RECOMMENDED SPARE PARTS ARE ITEMS NUMBER A3, PLUG (IF RUBBER FACED), A4, A5 AND A9.
2. WHEN ORDERING PARTS, INCLUDE VALVE SIZE AND PART NUMBER FROM DATA PLATE. ALSO INCLUDE THIS DRAWING NUMBER WITH PART NAME, NUMBER AND QUANTITY.
3. CLOCKWISE ROTATION OF PLUG STEM CLOSES VALVE.
4. 3" - 8" ARE THE ONLY SIZES FULLY RUBBER LINED.

Q	06/27/11
P	07/24/17
E	08/09/18
D	08/28/18
C	09/11/18
B	09/27/18
A	09/27/18

DeZURIK
AFCO | HILTON
www.dezurik.com

PEF 100% PORT ECCENTRIC VALVE ASSEMBLY
3-20, FLANGED

DOCT - CODE	DRANN	SN	APPROVED	SN
C1	CHECKED	SN	DATE	12/05/05

A55403

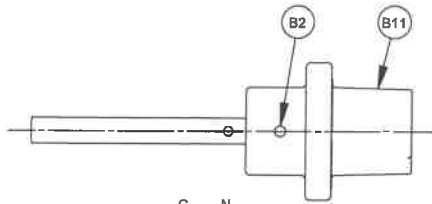

G_-N
WRENCHING SQUARE ACTUATOR

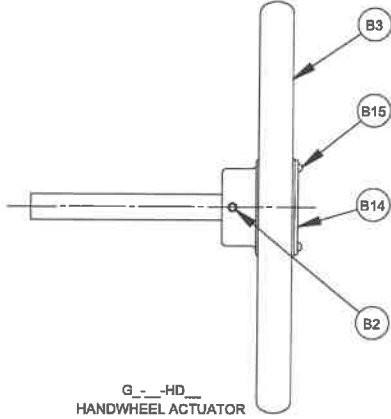

G_-HD
HANDWHEEL ACTUATOR

NOTE:

1. WHEN ORDERING PARTS, INCLUDE VALVE SIZE AND PART NUMBER FROM DATA PLATE. ALSO INCLUDE THIS DRAWING NUMBER WITH PART NAME, NUMBER AND QUANTITY.

2. TO CONVERT GS-(WEATHER PROOF) ACTUATOR TO GB-(BURIED SERVICE) ACTUATOR:

A. REMOVE POINTER.

B. APPLY A BEAD OF SILICONE SEALANT DOW RTV-732 (1055515) TO ACTUATOR MATING SURFACE OF COVER (B12), ASSEMBLE TO ACTUATOR AND ATTACH WITH SCREWS (B13).

C. BEFORE ADJUSTING ACTUATOR STOPS (B1P), LOOSEN JAM NUTS (B10) AND APPLY 2 WRAPS OF STRING PACKING (1013701) TO THE ACTUATOR STOP THREADS BETWEEN JAM NUTS AND ACTUATOR (B1).

NO	DESCRIPTION	QTY
B1	ACTUATOR ASSEMBLY	1
B1A	HOUSING	1
B1B	COVER	1
B1C	GEAR	1
B1D	WORM GEAR	1
B1E	BEARING	2
B1F	DRIVE SHAFT	1
B1G	BEARING RACE	4
B1H	THRUST BEARING	2
B1I	PIPE PLUG	2
B1J	SEAL	1
B1K	PIN	2
B1L	BEARING	2
B1M	SCREW	6
B1N	O-RING	2
B1O	NUT	2
B1P	SCREW	2
B1Q	POINTER	1
B1R	SCREW	2
B1S	PLUG	11
B1T	PLUG	1
B2	PIN (HANDWHEEL & WRENCHING SQUARE)	1
B2	PIN (CHAINWHEEL)	1
B3	HANDWHEEL	1
B4	CHAINWHEEL	1
B5	CHAIN GUIDE	1
B6	BEARING	1
B7	COLLAR	1
B8	SET SCREW	1
B9	CHAIN	-
B10	CLOSING LINK	1
B11	WRENCHING SQUARE	1
B12	COVER (BURIED SERVICE ONLY)	1
B13	SCREW (BURIED SERVICE ONLY)	3
B14	OPEN TAG (24", 30" & 36" HANDWHEEL ONLY)	1
B15	DRIVE SCREW (24", 30" & 36" HANDWHEEL ONLY)	2
B16	ADAPTOR	1
B17	SCREW	4
B18	LOCKWASHER	4
B19	BEARING	1
B20	PIN (CHAINWHEEL)	1

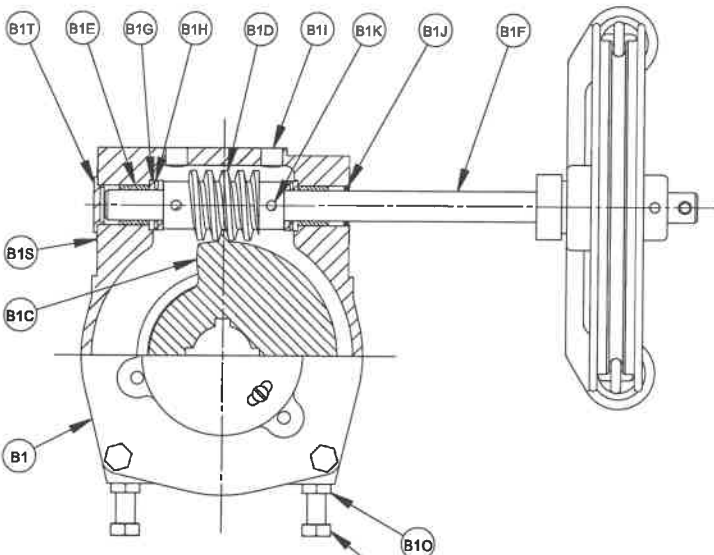

GB-_-
BURIED SERVICE ACTUATOR

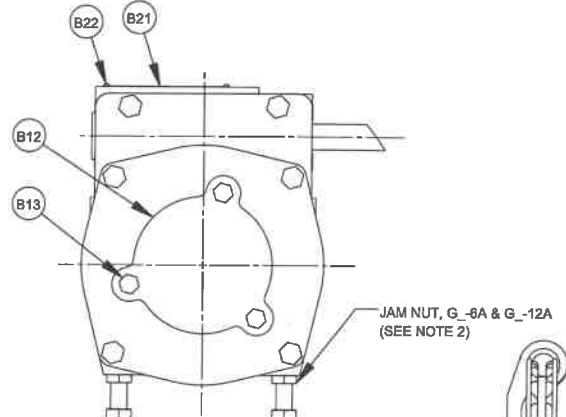

JAM NUT, G_-8A & G_-12A
(SEE NOTE 2)

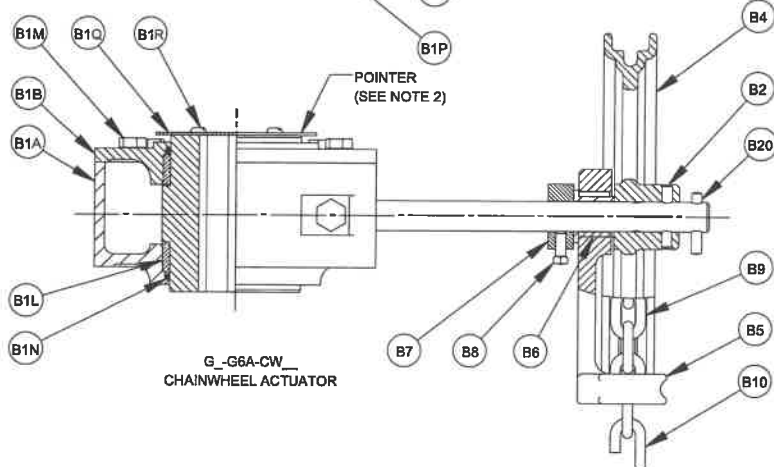

G_-G6A-CW
CHAINWHEEL ACTUATOR

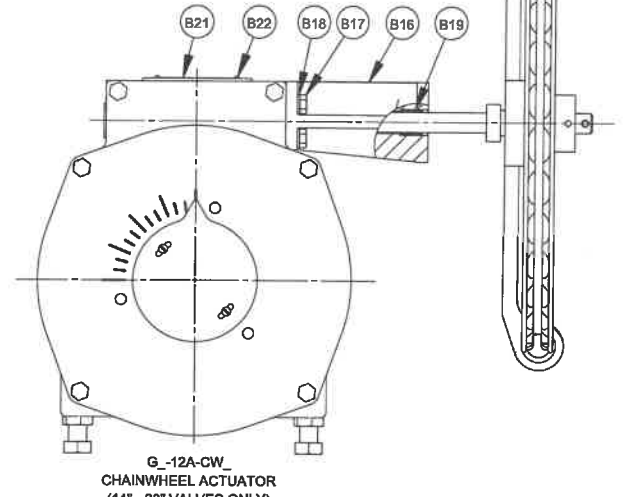

G_-12A-CW
CHAINWHEEL ACTUATOR
(14" - 20" VALVES ONLY)

REV	DATE	BY	CHKD
1	01/04/11	LE	
2	06/28/13	13	
3	07/15/09	09	
4	01/05/06	06	
5	05/20/06	06	

DeZURIK
Sartell, MN USA 56377
www.dezurik.com

GS-6A, GB-6A, GS-12A & GB-12A MANUAL ACTUATORS WITH CHAINWHEEL, HANDWHEEL AND WRENCHING SQUARE (NUT)

DOCT CODE	DRAWN	TC	APPROVED	SN
C1	CHECKED	SN	DATE	12/16/05

A55615

NO	PART NAME	QTY
P1	ADAPTOR	1
P2	SCREW (3 & 4 VALVES)	4
P2	SCREW (5 - 12 VALVES)	6
P2	SCREW (14 - 20 VALVES)	8
P3	SCREW	4

NOTE:

1. WHEN ORDERING PARTS, INCLUDE VALVE SIZE AND PART NUMBER FROM DATA PLATE. ALSO INCLUDE THIS DRAWING NUMBER WITH PART NAME, NUMBER AND QUANTITY.

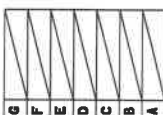
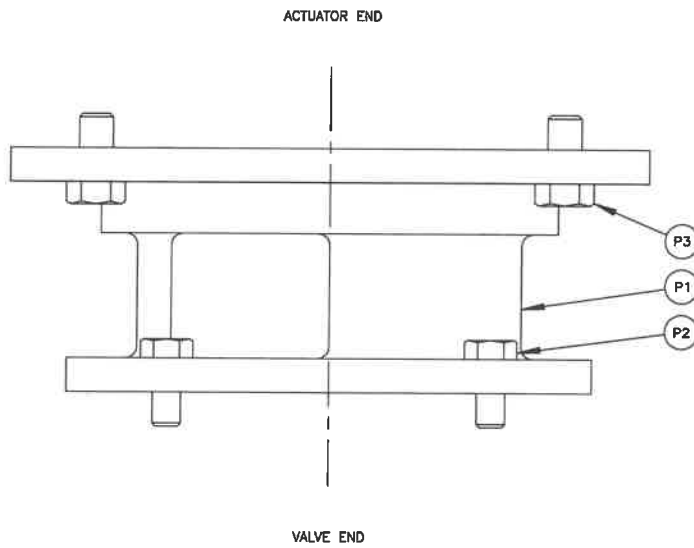

DeZURIK
 Sartell, MN USA 56377
 www.dezurik.com

CONNECTING PARTS FOR G...A MANUAL ACTUATORS
 FOR USE WITH PEF ECCENTRIC PLUG VALVES

DOCT. CODE	DRAWN	TC	APPROVED	SN
C1	CHECKED	SN	DATE	11/02/05

A55418

VALVE SIZE		DIMENSIONS												
INCH	MM	A	B	C	D	E	F	G	H	J	K	L	M	N
14	350	18.75 476	1-8 UNC	8	4	.38 10	10.50 267	.81 21	3.00 76	8.25 210	21.00 533	54.75 1391	40.82 1037	20.00 508
16	400	21.25 540	1-8 UNC	10	6	.38 10	11.75 298	.88 22	3.50 89	8.62 221	24.50 622	58.44 1484	42.38 1076	20.00 508
18	450	22.75 578	1-1/8-7 UNC	10	6	.43 11	12.50 318	.94 24	3.50 89	9.06 230	25.50 648	67.75 1721	49.69 1262	20.00 508
20	500	25.00 635	1-1/8-7 UNC	12	8	.43 11	13.75 349	1.00 25	4.50 114	9.19 233	28.50 724	71.31 1811	51.25 1302	20.00 508
22	550	27.25 692	1-1/4-7 UNC	12	8	.43 11	15.5 394	1.00 25	4.50 114	9.19 233	31.00 787	77.22 1961	55.36 1406	20.00 508
24	600	29.50 749	1-1/4-7 UNC	12	8	.43 11	16.00 406	1.00 25	4.50 114	9.19 233	33.50 851	83.29 2116	59.22 1504	20.00 508

A	VALVE
B	ACTUATOR

- NOTE:
1. VALVE IS SHOWN IN CLOSED POSITION.
 2. VALVE ORDERED WITH THRU BOLTING HAVE ALL HOLES, EXCEPT THOSE THAT ARE BLIND TAPPED, DRILLED TO ANSI STANDARDS CLASS 125 & 150.
 3. DRAWING SHOWS FLANGES TAPPED FOR THE USE WITH ANSI FLANGES, FOR USE WITH OTHER THAN ANSI FLANGES SEE A-82587.
 4. VEE ORIFICE OPTION IS SHOWN ON DRAWING WITH PHANTOM LINES.
 5. INSTALL THE VALVE WITH THE HIGHER PRESSURE AGAINST THE SIDE OPPOSITE THE SEAT WHEN THE VALVE IS CLOSED; EXCEPT AT THE BOTTOM OF DRY MATERIAL STORAGE VESSELS WHERE THE VALVE SHOULD BE INSTALLED WITH THE SEAT UPWARD.

NOTICE
THIS DRAWING DOES NOT SHOW ACTUATOR ACCESSORIES, IF ACCESSORIES ARE REQUIRED, REFER TO THE APPROPRIATE ACCESSORY INSTALLATION DRAWING FOR DIMENSIONS AND OTHER RELATED INFORMATION.

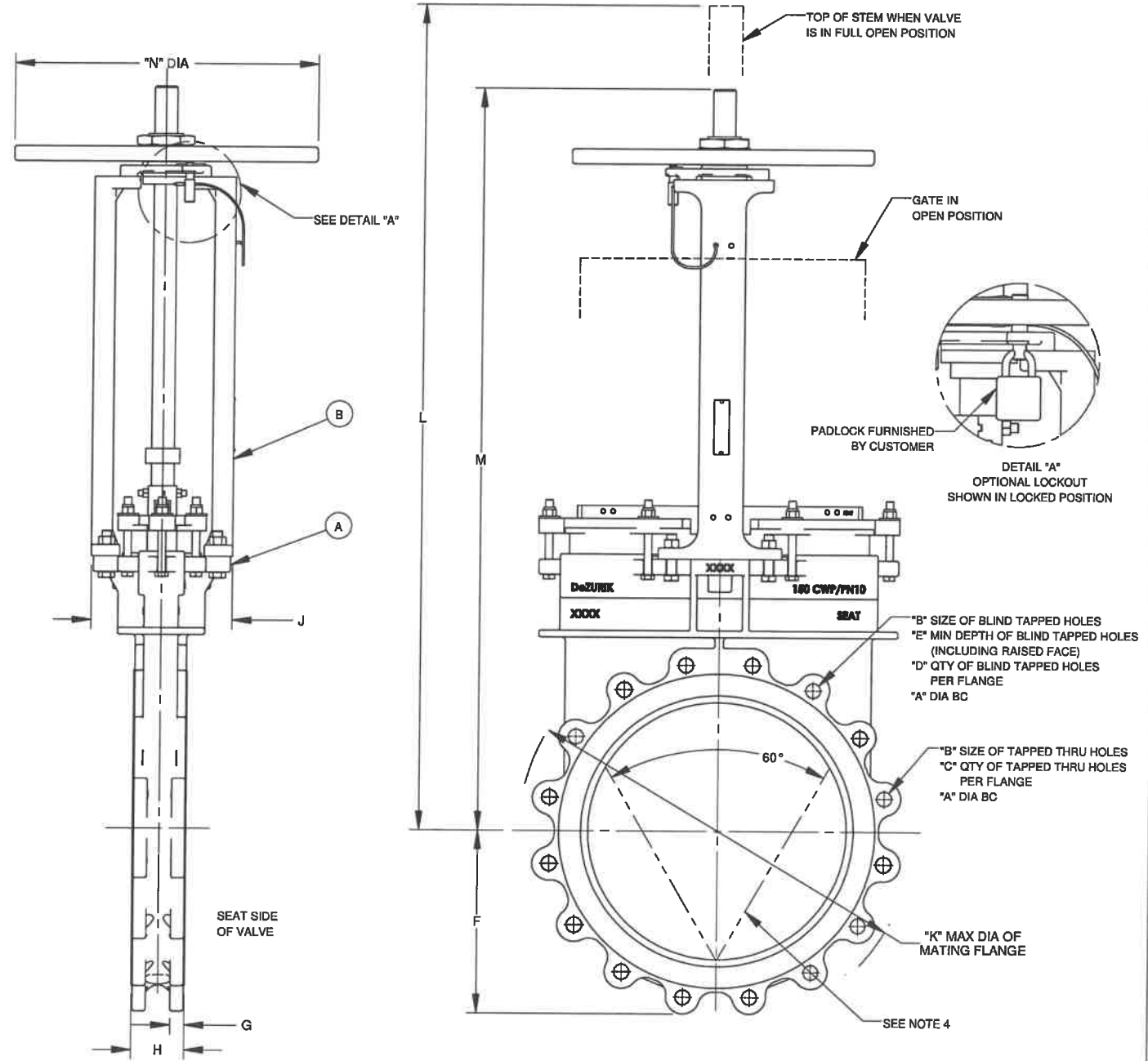

C	PCN# 62561	8/5/2015	SW	AB
B	PCN 62474	03/22/13	SW	DN
A	P.C.N. 62428	1/17/2013	SW	WL
REV.	DESCRIPTION	DATE	APPROVED	DRAWN
REVISIONS				

DeZURIK
Sartell, MN USA 56377
www.dezurik.com

KGC ES KNIFE GATE VALVES SIZE 14 - 24
MN-HD20 HANDWHEEL ACTUATED

DOCT. CODE	DRAWN	APPROVED	RT
C1	RT	RT	RT
CHECKED	DATE	DATE	DATE
		4/20/12	

A59095

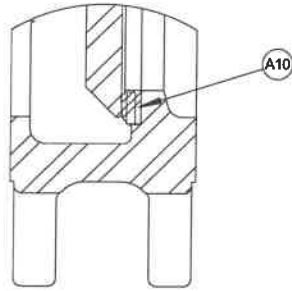

RUBBER SEATED OPTION

NO.	PART NAME	QTY.
A1	BODY	1
A2	PACKING	-
A3	GATE	1
A4	GLAND	1
A5	SCREW (2" - 6" VALVE)	2
A5	SCREW (8" - 12" VALVE)	4
A5	SCREW (14" - 24" VALVE)	6
A6	WASHER (2" - 6" VALVE)	2
A6	WASHER (8" - 12" VALVE)	4
A6	WASHER (14" - 24" VALVE)	6
A7	NUT (2" - 6" VALVE)	2
A7	NUT (8" - 12" VALVE)	4
A7	NUT (14" - 24" VALVE)	6
A8	PACKING CORD	-
A9	ANTI-EXTRUSION RING	1
A10	REMOVABLE SEAT	1

NOTE:

1. WHEN ORDERING PARTS, SPECIFY VALVE SIZE AND MODEL NUMBER FROM DATA PLATE, ALSO GIVE DRAWING NUMBER WITH PART NAME, ITEM NUMBER AND QUANTITY.
2. RECOMMENDED SPARE PARTS ARE ITEMS NO. A2, A8, A9 AND A10.

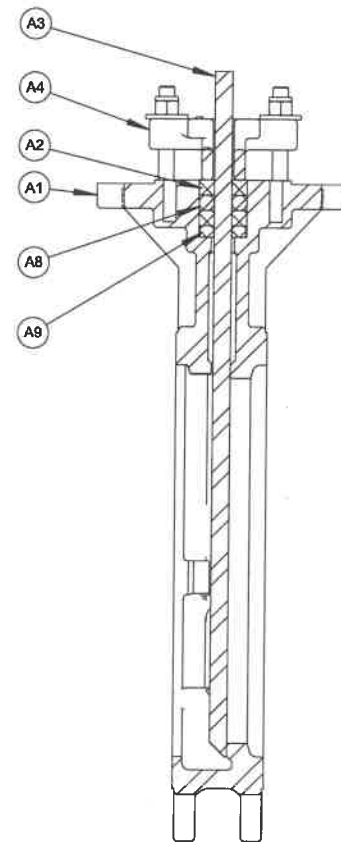
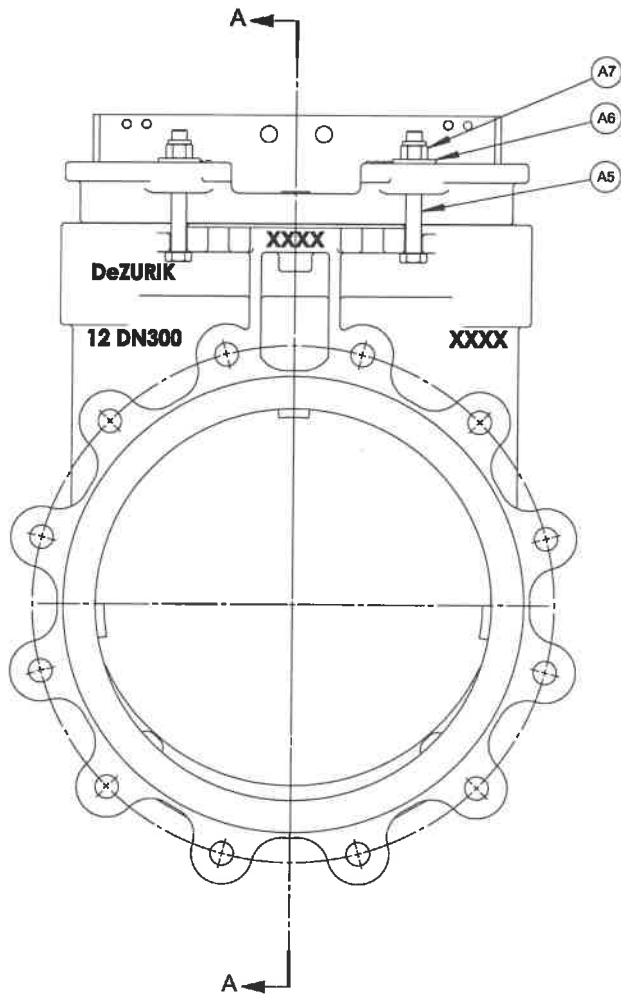

SECTION A-A

C	L	E	D	C	B	A
				62550	9/24/13	6/15/10
				151935		



KGC ES VALVE ASSEMBLY 2" - 24" FLANGED KNIFE GATE VALVE			
DOC. CODE	DRAWN	CHECKED	APPROVED
C1	CMW	CS	DLT
			DATE
			6/18/02

A46357

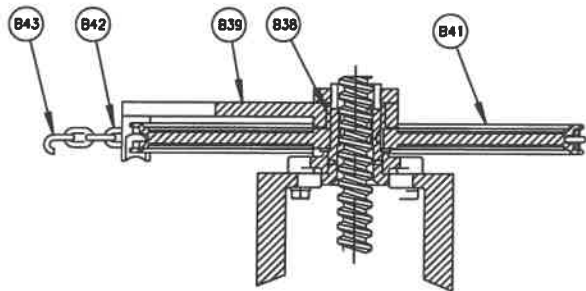

MN-CW_ CHAINWHEEL ACTUATOR
14" THRU 20" VALVES ONLY

NO.	PART NAME	QTY.
B1	SCREW	2
B2	LOCK NUT	2
B3	STEM	1
B4	LEG	2
B5	SCREW	4
B7	NUT	4
B8	CLIP	2
B9	POP RIVET	2
B10	DATA PLATE	1
B11	MANUAL ADAPTOR	1
B12	SCREW	4
B13	LOCKWASHER	4
B14	STOP COLLAR	1
B15	SET SCREW	1
B17	GREASE FITTING	1
B18	YOKE SLEEVE	1
B21	THRUST WASHER	1
B22	NUT	1
B23	KEY	1
B32	HANDWHEEL	1
B33	SET SCREW	1
B38	BEARING	1
B39	CHAIN GUIDE	1
B41	CHAINWHEEL	1
B42	CHAIN	-
B43	CLOSING LINK	1
B45	LOCKOUT PIN (MN-HD_ ONLY)	1
B46	PIN (MN-HD_ ONLY)	1
B47	CABLE (MN-HD_ ONLY)	-
B48	CABLE CLAMP (MN-HD_ ONLY)	2

NOTE:

1. WHEN ORDERING PARTS, SPECIFY VALVE SIZE AND MODEL NUMBER FROM DATA PLATE, ALSO GIVE DRAWING NUMBER WITH PART NAME, ITEM NUMBER AND QUANTITY.
2. RECOMMENDED SPARE PARTS ARE ITEMS NO. B21.
3. OPTIONAL LOCKOUT PARTS B45, B46, B47 & B48 ARE FURNISHED WHEN LK(LOCKOUT) ACCESSORIES ORDERED.

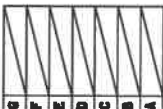
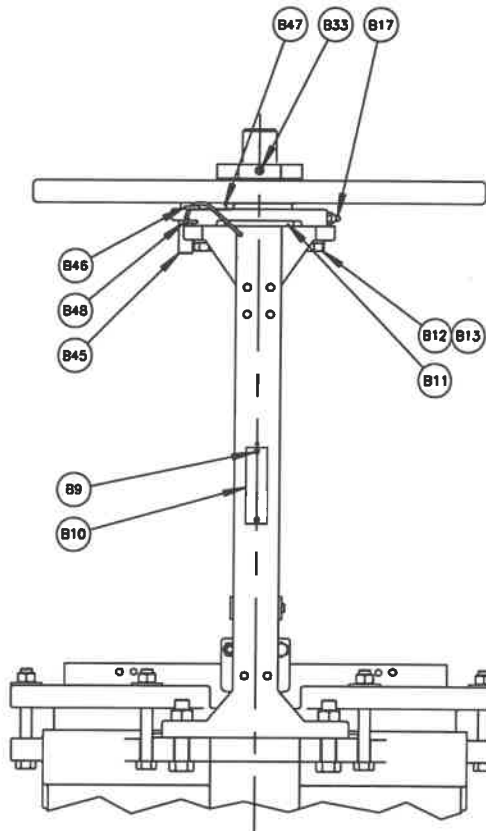
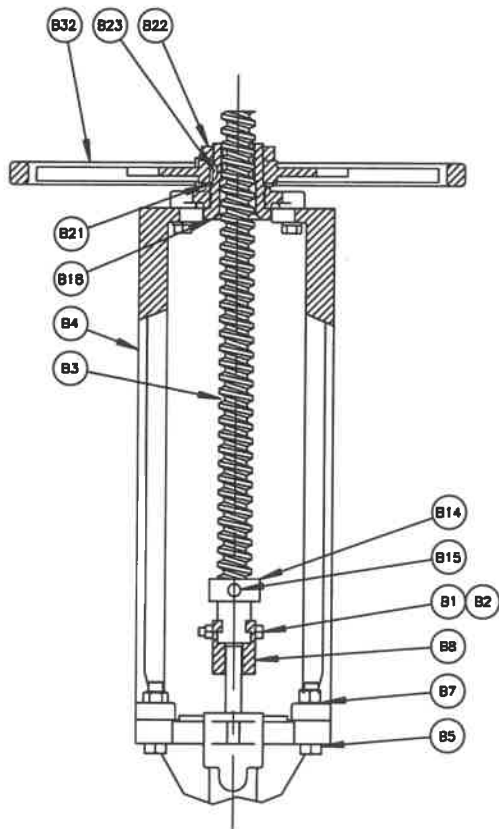

DeZURIK
Sartell, MN USA 56377
www.dezurik.com

MN-HD_ HANDWHEEL ACT'R & MN-CW_ CHAINWHEEL ACT'R
AND OPTIONAL LOCKOUT FUW 14 - 24 KGC KNIFE GATE VALVES

DECT. CODE	DRWN	JJD	APPROVED	DLT
C1	CHECKED	CS	DATE	08/18/02

A-47224

PDF



DeZURIK 3-36" PEF 100% PORT ECCENTRIC PLUG VALVES

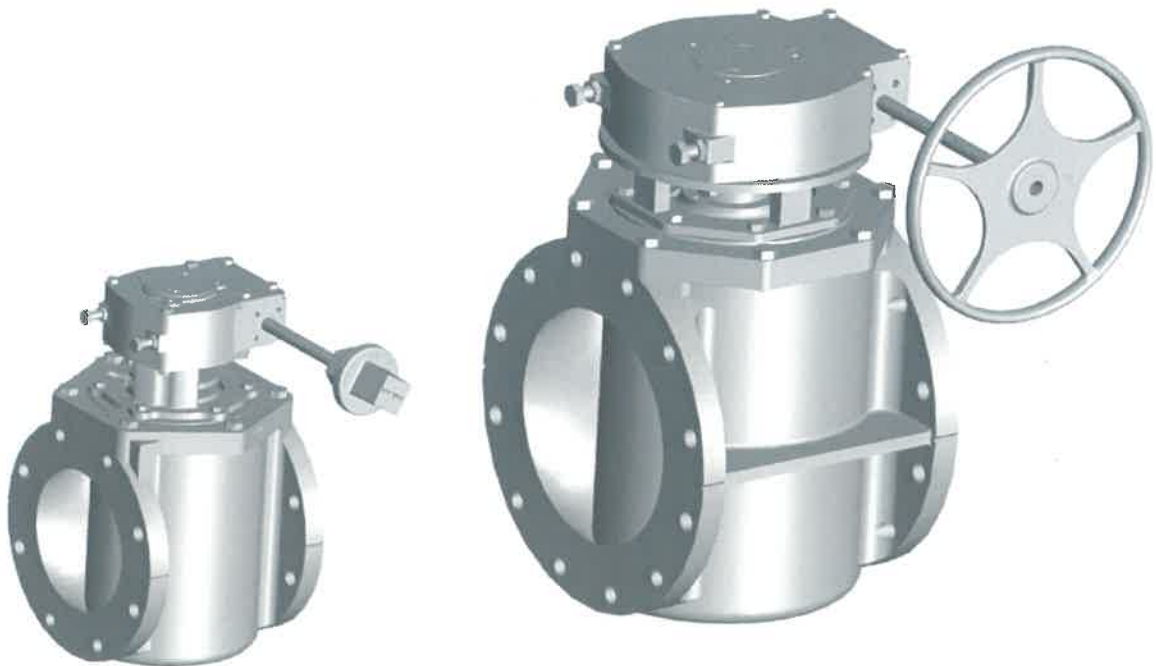

Instruction 
February 2019

DeZURIK

3-36" PEF 100% Port Eccentric Plug Valves*

Instructions

These instructions provide information about PEF 100% Port Eccentric Plug Valves. They are for use by personnel who are responsible for installation, operation and maintenance of PEF 100% Port Eccentric Plug Valves.

Safety Messages

All safety messages in the instructions are flagged with an exclamation symbol and the word Caution, Warning or Danger. These messages indicate procedures that must be followed exactly to avoid equipment damage, personal injury or death.

Safety label(s) on the product indicate hazards that can cause equipment damage, personal injury or death. If a safety label becomes difficult to see or read, or if a label has been removed, please contact DeZURIK for replacement label(s).



WARNING!

Personnel involved in the installation or maintenance of valves should be constantly alert to potential emission of pipeline material and take appropriate safety precautions. Always wear suitable protection when dealing with hazardous pipeline materials. Handle valves, which have been removed from service with suitable protection for any potential pipeline material in the valve.

Inspection

Your PEF 100% Port Eccentric Plug Valve has been packaged to provide protection during shipment, however, it can be damaged in transport. Carefully inspect the unit for damage upon arrival and file a claim with the carrier if damage is apparent.

Parts

Recommended spare parts are listed on the assembly drawing. These parts should be stocked to minimize downtime.

Order parts from your local DeZURIK sales representative, or directly from DeZURIK. When ordering parts, please include the 7-digit part number and 4-digit revision number (example: **9999999R000**) located on the data plate attached to the valve assembly. Also include the part name, the assembly drawing number, the balloon number and the quantity stated on the assembly drawing.

DeZURIK Service

DeZURIK service personnel are available to install, maintain and repair all DeZURIK products. DeZURIK also offers customized training programs and consultation services.

For more information, contact your local DeZURIK sales representative or visit our website at www.dezurik.com.

* Patent Applied For

Table of Contents

Description -----	4
Handling -----	4
Required Tools -----	4
Fusion/Powder Coated Valves -----	4
Installation -----	5
Liquids without Suspended Solids and Clean Gases -----	5
Liquids with Suspended Solids and Dirty Gases -----	7
Actuator Stop Adjustments	
Closed Position -----	9
Lubrication -----	9
Packing -----	9
Plug Journals -----	10
Thrust Washers and O-rings -----	10
Packing Adjustment -----	10
3 – 8" Lever and Nut Operated Valves -----	10
All Other Actuators -----	10
Parts Identification -----	11
Packing Replacement	
Replace packing with Actuator Removed -----	12
Replace Packing without Removing Actuator -----	14
Disassembly -----	15
Reassembly -----	17
Removing Valve from Pipeline -----	18
Field Test -----	19
Valve Exercising -----	19
Emergency Operation -----	19
Predict Wear of Parts -----	19
Troubleshooting -----	19

DeZURIK

3–36" PEF 100% Port Eccentric Plug Valves

Description

The 3– 36" PEF 100% Port Eccentric Plug Valves have welded nickel seats that provide excellent resistance to corrosion and damage, and prolong the life of the resilient plug facing. The valve rotates 90 degrees from full open to full closed. Clockwise rotation of the valve stem closes the valve.

If an actuator other than a DeZURIK is to be mounted, the actuator must be capable of seating and unseating the plug and maintaining the valve plug position with flow in the pipeline.



WARNING!



This valve is a pressure vessel. Failure to release pipeline pressure may result in personal injury and/or flow system damage. Completely release pipeline pressure before removing the actuator from the valve or removing the valve from the pipeline.

Handling

Lifting the valve improperly may damage it. Do not fasten lifting devices to the actuator, plug or through the seat opening in the body. Lift the valve with slings, chains or cables fastened around the valve body, or fastened to bolts or rods through bolt holes in the flanges.

Required Tools

This valve is assembled using only metric fasteners. To service this valve, you should have a full set of combination wrenches, Allen wrenches, a large flat tipped screwdriver, a flat pry bar, a pin punch and a dead blow hammer.

-  You may want to machine a shaft to aid you in removing the lower bearing from the body. See
-   section.

Fusion/Powder Coated Valves



CAUTION!

Valves with fusion/powder coated exterior paint require flat washers to be installed under the flange nuts when installing the valve to the pipeline flange to prevent the paint from cracking or chipping.

Installation

The type of materials carried in the pipeline and the location of the valve determine the correct installation procedure.

Rust Veto may be removed with the use of Houghton Kleensol #4 or petroleum solvent.

Liquids without Suspended Solids and Clean Gases

1. Before installation, remove foreign material such as weld spatter, oil, grease, and dirt from the pipeline.
2. Prepare pipe ends and install valves in accordance with the pipe manufacture's instructions for the joint used.

Note: See Figure 1 for proper valve orientation.



CAUTION!

Do not deflect the pipe-valve joint. Minimize bending stresses in the valve end connection with pipe loading.

3. Ensure the valve and flanges are concentric to ensure proper flange sealing.
4. Tighten the flange bolts or studs in a crisscross pattern.

Installation *(Continued)*

Liquids with Suspended Solids and Dirty Gases

If the pipeline carries suspended solids such as paper stock of 2 percent or higher consistency, mining slurry, or raw sewage:

1. Before installation, remove foreign material such as weld spatter, oil, grease, and dirt from the pipeline.
2. Prepare pipe ends and install valves in accordance with the pipe manufacture's instructions for the joint used.

Note: See Figure 2 for proper valve orientation.

- a. In HORIZONTAL pipelines, install the valve so that the plug is horizontal and rotates upward as the valve opens.
- b. For VERTICAL pipelines, install the valve with the end marked "SEAT" at top of valve.



CAUTION!

Do not deflect the pipe-valve joint. Minimize bending stresses in the valve end connection with pipe loading.

3. Ensure the valve and flanges are concentric to ensure proper flange sealing.
4. Tighten the flange bolts or studs in a crisscross pattern.

Installation (Continued)

INSTALLATION - Liquids with Suspended Solids and Dirty Gases

The proper installation of a DeZURIK PEF 100% Eccentric Plug Valve in suspended solids applications such as mining slurries, raw sewage or paper stock of 2% or more consistency is critical to prevent solids from packing into the valve body, restricting the plug movement. This can be accomplished by

installing the valve with the flow against the face of the plug in the closed position and the valve on its side with the plug rotating to the top of the pipeline in the open position. For pump isolation service, install the valve with the seat side opposite the pump and with the plug rotating to the top of the pipeline in the open position. On the suction side, install the valve with the seat toward the pump.

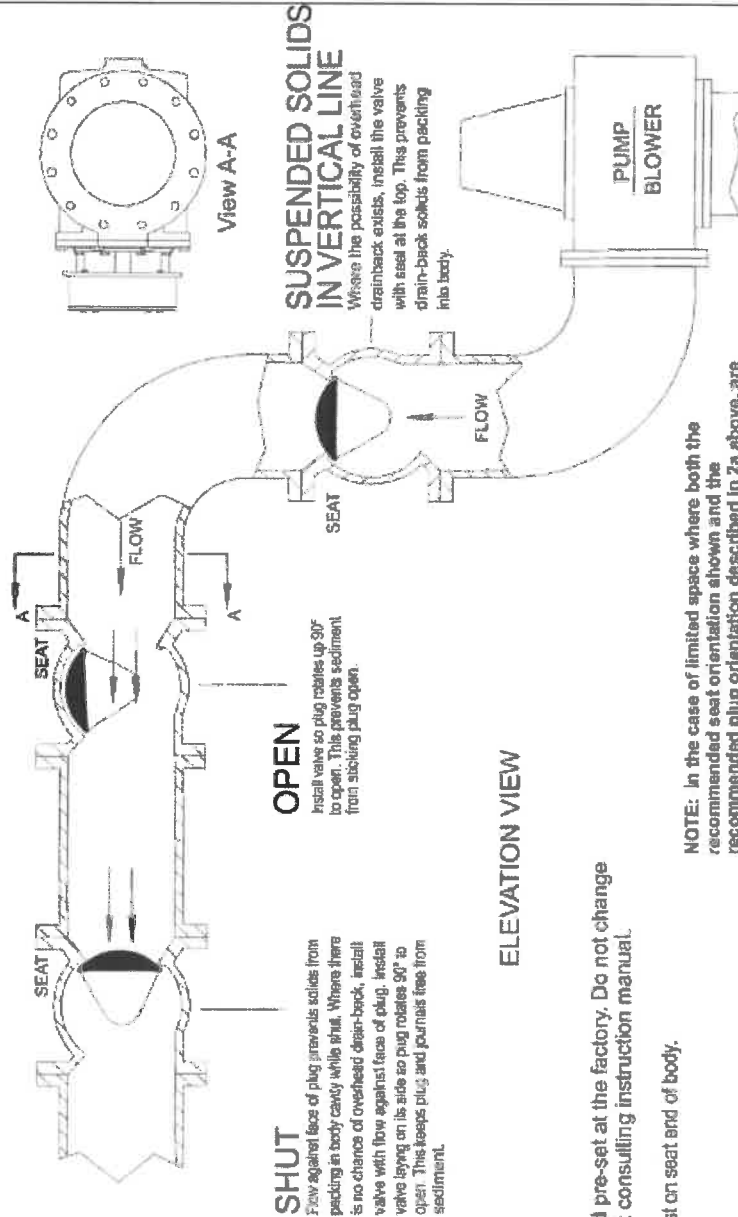

NOTE - 1. Units are tested and pre-set at the factory. Do not change adjustments without consulting instruction manual.

2. The word "SEAT" is cast on seat end of body.

Figure 2—Liquids with Suspended Solids and Dirty Gases

Actuator Stop Adjustments

Closed Position

Because of the eccentric action of this valve, the closed position of the valve is dependent upon the pressure drop expected when the valve is closed. To adjust the valve closed position, follow these steps:



WARNING!

This valve is a pressure vessel. The bonnet will blow off the valve if the bonnet bolts are removed with pressure in the valve and pipeline media can be hazardous. Completely release pressure before disassembling the valve.

1. Relieve pipeline pressure.



WARNING!

Moving parts from accidental operation of power actuator can cause personal injury or equipment damage.

Disconnect and lock out power to actuator before servicing.

2. If the actuator is powered, disconnect and lock out the pneumatic, hydraulic, or electrical power to prevent accidental operation of the actuator.
3. Back off the actuator closed position stop as described in the Actuator Instructions.
4. Close the valve with the torque specified in the Actuator Instructions.
Note: This torque is the amount required to seat the plug for a given pressure drop across the valve. To avoid excessive plug and seat wear caused by over torquing, use the actual pressure drop across the valve when determining correct closing torque.
5. After the valve has been closed using the correct amount of torque, set the actuator closed position stop to limit actuator travel at this position.

Lubrication

This valve does not require routine maintenance lubrication, except for special application. If the valve is disassembled, lubricate the packing and the plug journals as follows:

Packing

Packing lubrication requirements are dependent upon the packing material.

- PTFE PACKING: Requires no lubrication.
- ALL PACKING OTHER THAN PTFE:
Apply a light coat to the inside and outside diameters of the packing rings using one of these lubricants.
 - Lubriplate Clearplex-2 (**recommended**)
 - Amoco FG (alternate)
 - Mobilgrease FM 101 (alternate)
 - Petro-Canada Purity FG 2 (alternate)
 - Phillips Philube PF (alternate)

Note: Ensure lubricant is compatible with flow media.

DeZURIK

3-36" PEF 100% Port Eccentric Plug Valves

Lubrication *(Continued)*

Plug Journals

Plug journal lubrication is dependent upon the materials used in construction of the valve.

- **CAST IRON VALVES:** Lubricate the journals on the plug using one of these lubricants.
 - Lubriplate Clearplex-2 (**recommended**)
 - Amoco FG (alternate)
 - Mobilgrease FM 101 (alternate)
 - Petro-Canada Purity FG 2 (alternate)
 - Phillips Philube PF (alternate)

Note: Ensure lubricant is compatible with flow media.

Thrust Washers and O-rings

Apply a light coat to all surfaces of thrust washers and O-rings using one of these lubricants.

- Lubriplate Clearplex-2 (**recommended**)
- Phillips Philube PF (alternate)
- Mobilgrease FM 101 (alternate)
- Amoco FG (alternate)

Note: Ensure lubricant is compatible with flow media.

Packing Adjustment

The stem seal tightening procedure is dependent upon the type of actuator on the valve. If a packing leak should occur, tighten the packing as follows:

3" – 8" Lever and Nut Operated Valves

Table A: Actuating Torque

Valve Size		Actuating Torque	
		Standard Packing	
in	mm	ft lbs	Nm
3 & 4	100	28	37
5 & 6	125-150	60	81
8	200	104	141

All Other Actuators

Tighten the gland nuts evenly only until the leak stops.

Note: Do not continue tightening after leak stops. If packing leak cannot be stopped by tightening the gland nuts, the packing must be replaced.

DeZURIK

3-36" PEF 100% Port Eccentric Plug Valves

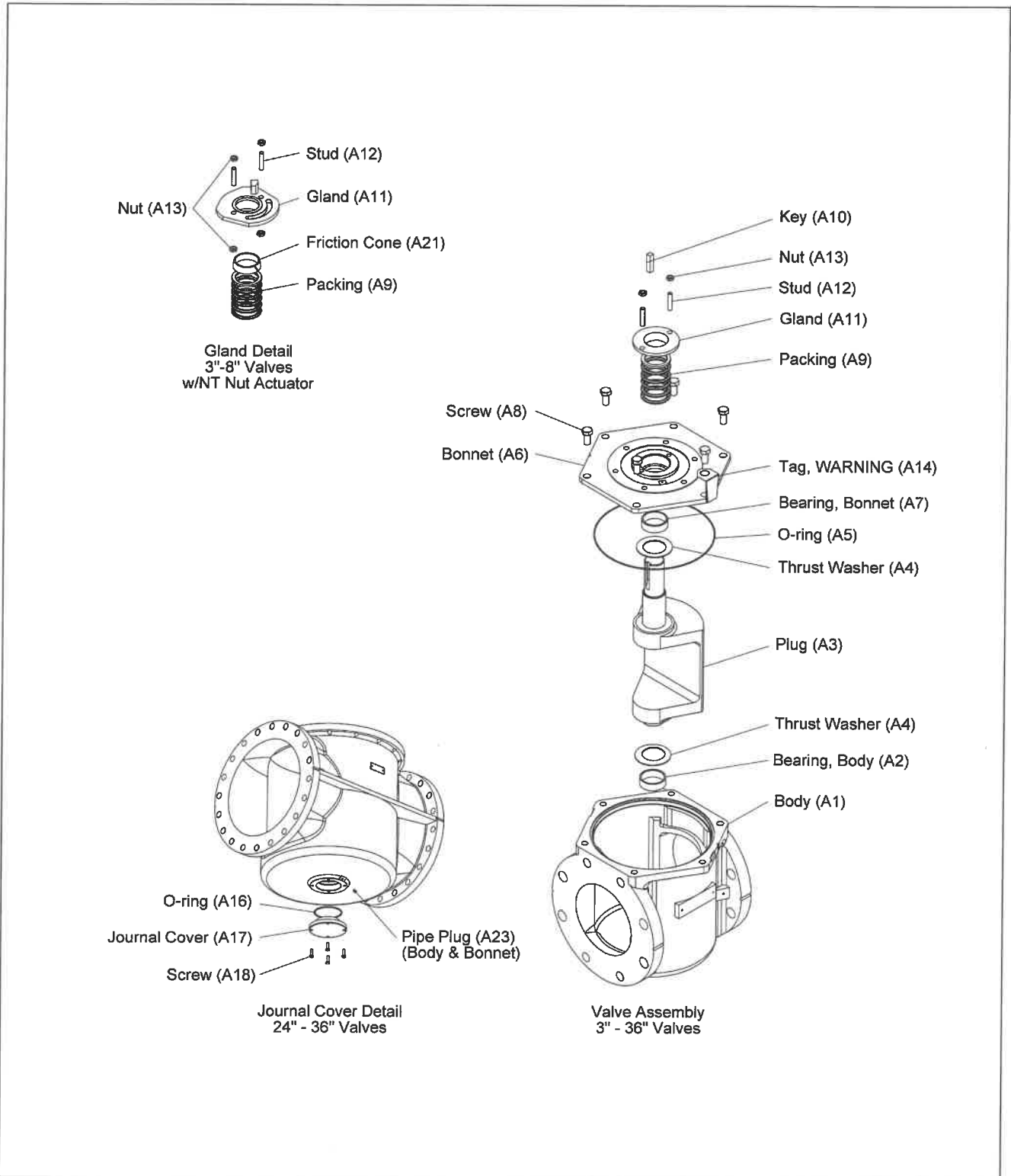

Figure 3—Parts Identification

DeZURIK

3-36" PEF 100% Port Eccentric Plug Valves

Packing Replacement

Replacing Packing with Actuator Removed

To replace the packing without removing actuator, see the "Replacing Packing Without Removing Actuator" section.

See Figure 3 for parts identification.

1. Discontinue pipeline flow and relieve pipeline pressure.
2. Scribe the actuator and valve bonnet for alignment when reassembling.



WARNING!

Moving parts from accidental operation of power actuator can cause personal injury or equipment damage. Disconnect and lock out power to actuator before servicing.

3. If the actuator is powered, disconnect and lock out the pneumatic, hydraulic, or electrical power to prevent accidental operation of the actuator.



WARNING!

When an eccentric valve is mounted in a vertical pipeline—or mounted in a horizontal pipeline with the plug stem horizontal—gravity can cause the plug to swing to a lower position in the valve body when the actuator is removed. Place the plug in the lowest position before removing the actuator.

4. Remove the actuator from the valve. See Actuator Instructions.
5. Remove the actuator adaptor from the valve.
6. Remove the gland nuts (A13), then slide the gland (A11) off the plug shaft (A3).
7. Pull the packing (A9) out of the bonnet (A6).
8. For valves with gear actuators, lubricate the new packing (A9), then install it one ring at a time in the sequence shown in Figure 4.

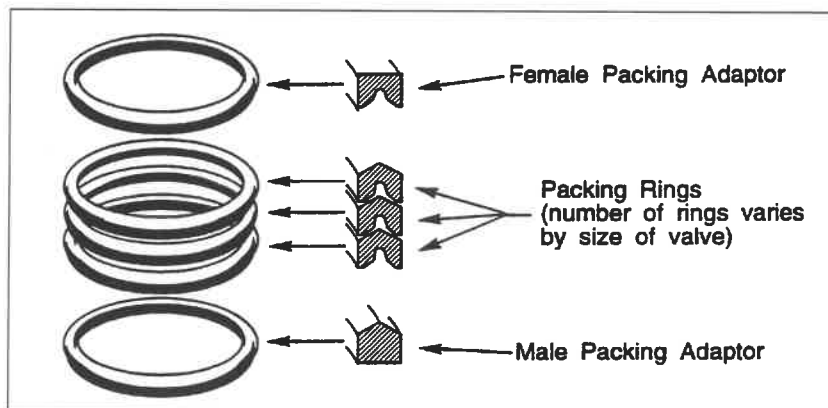

Figure 4 - Correct Packing Installation Sequence

DeZURIK

3-36" PEF 100% Port Eccentric Plug Valves

Packing Replacement (Continued)

Note: 3 - 8" lever and nut operated valves have a friction cone (A21) and standard packing (A9). Before installing the gland (A11), set the friction cone on top of the packing. Do not lubricate the outside of the friction cone or the inside of the gland. See Figure 5.

9. Slide the gland (A11) down the plug shaft (A3) and over the studs (A12). If the valve has a friction cone (A21), bring the gland nuts (A13) under the gland up finger tight.

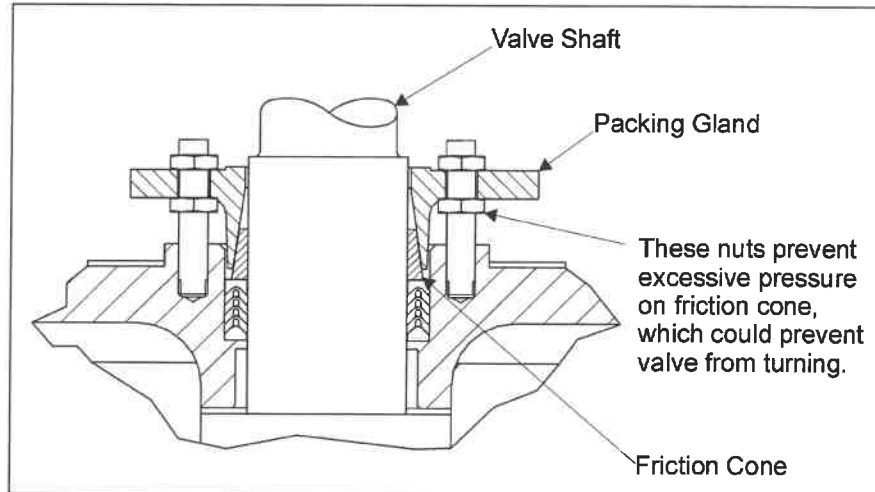

Figure 5—Friction Cone Adjustment

10. Adjust gland nuts (A13).

3 - 8" LEVER AND NUT OPERATED VALVES ONLY:

Turn gland nuts (A13) onto the studs (A12) until they touch the gland (A11).

Note: This is a preliminary adjustment, it will be necessary to adjust the gland nuts (A13) after the valve is pressurized. See "Packing Adjustment" section.

11. Fasten the adaptor (when used) to the valve, lining up the scribe marks made during disassembly.
12. Install the actuator as described in the Actuator Instructions.
13. If the actuator is a powered actuator, reconnect power to the actuator.

DeZURIK

3-36" PEF 100% Port Eccentric Plug Valves

Packing Replacement *(Continued)*

Replacing Packing Without Removing Actuator

Note: Lever and nut operated valves require that the actuator be removed before packing can be replaced. See "Replacing Packing with Actuator Removed" section to replace the packing in these valves.

1. This process can be done with or without pressure in the pipeline.



WARNING!

Caustic, toxic, or hot material in the pipeline can cause personal injury or death if leakage occurs. Confirm that the material is not harmful.

2. Ensure that the material in the pipeline will not cause injury if leakage occurs.
3. Remove the gland nuts (A13) from the studs (A12), and slide the gland (A11) up the stem of the plug (A3).
4. Remove the studs (A12) from the bonnet (A6).
5. Cut and completely remove all of the old packing (A9) from the packing chamber in the bonnet (A6).
6. Cut each new packing ring (A9) radially in one place with a razor-sharp knife.
7. Place each new packing ring (A9)—one at a time with the joints staggered—around the plug stem (A3) and into position in the packing chamber.
8. Replace the studs (A12) in the bonnet (A6).
9. Push the packing rings (A9) down into position with the gland (A11), and replace the gland nuts (A13) on the studs (A12).
10. Turn the gland nuts (A13) onto the studs (A12) until they touch the gland (A11), then one more turn.
11. Restore the pipeline pressure if it was relieved, and check for packing leakage. If leakage occurs, tighten each packing nut just enough to stop the leakage. Excessive tightening will cause reduced packing life and higher valve operating torque.

Disassembly

See Figure 3 for parts identification.



WARNING!

This valve is a pressure vessel. The bonnet will blow off the valve if the bonnet bolts are removed with pressure in the valve and pipeline media can be hazardous. Completely release pressure before disassembling the valve.

Follow these steps to disassemble valve:

1. Relieve pipeline pressure and close the valve.



WARNING!

Moving parts from accidental operation of power actuator can cause personal injury or equipment damage.

Disconnect and lock out power to actuator before servicing.

2. If the actuator is powered, disconnect and lock out the pneumatic, hydraulic, or electrical power to prevent accidental operation of the actuator.
3. Close the valve.
4. Remove the valve from the pipeline (if desired).

Note: The valve can be disassembled while still in the pipeline. To remove valve from pipeline, see "Removing Valve from Pipeline" section.



WARNING!

When an eccentric valve is mounted in a vertical pipeline—or mounted in a horizontal pipeline with the plug stem horizontal—gravity can cause the plug to swing to a lower position in the valve body when the actuator is removed.

Place the plug in the lowest position before removing the actuator.

5. Remove actuator from valve—see Actuator Instructions.
6. Scribe a line on the body (A1), bonnet (A6) and plug stem (A3) to help align these parts during reassembly.
7. Remove the screws (A8) that hold the bonnet (A6) in place, then pry the bonnet loose from the body (A1).
Note: Note the location of **WARNING TAG** (A14) on bonnet (A6) and do not misplace tag. This tag must be attached to the valve at reassembly.
8. Remove the plug (A3) from the body (A1).
9. Remove the gland nuts (A13) and gland (A11) from the bonnet (A6).
10. Remove the packing (A9) from the bonnet (A6).

DeZURIK

3-36" PEF 100% Port Eccentric Plug Valves

Disassembly (Continued)

11. Reaching through the packing chamber in the bonnet (A6), drive the bearing (A7) out of the bonnet using a hammer and pin punch.

12. Remove the bearing (A2) from the body (A1).

For 3" - 20" valves, the bearing (A2) can be chiseled out; or, it can be hydraulically forced out. See Figure 6.

For 24" - 36" valves, the bearing (A2) can be driven out of the body (A1) using a hammer and pin punch. First remove the screws (A18) and journal cover (A17) from the body. Remove the old o-ring (16) from the journal cover.

To hydraulically force the bearing (A2) out of 3" - 20" valve body:

1. Fill the interior diameter of the bearing (A2) with water.
2. Pound a shaft with the same outside diameter as the lower journal of the valve plug into the bearing (A2).

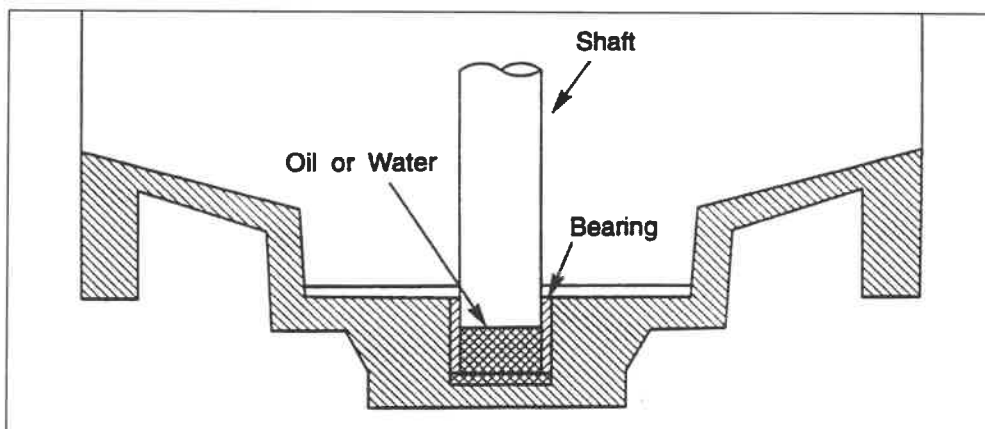

Figure 6—Hydraulically Removing the Lower Bearing in the Valve Body

Reassembly

See Figure 3 for parts identification.

1. Push a new bearing (A2) into the body (A1), then lubricate the bearing as described in the "Lubrication" section.
2. For **24" - 36" valves**, place a new o-ring (A16) in the groove of the journal cover (A17). Fasten the journal cover to the body (A1) with screws (A18).
3. Place a Teflon thrust washer (A4) on the top and bottom shoulder of the plug shaft (A3).
4. Place the plug (A3) into the body (A1) so the lower journal slides into the bearing (A2). Turn the plug so it is almost closed.
5. If necessary, push a new bearing (A7) into the bonnet (A6), then lubricate the bearing. See "Lubrication" section.
6. For **3" - 20" valves**, place an o-ring (A5) in the bonnet (A6).

For **24" - 36" valves**, place an o-ring (A5) into the o-ring groove of the body (A1).

7. Place bonnet (A6) on body (A1), align witness marks, then fasten bonnet in place with screws (A8).



WARNING!

This valve is a pressure vessel and has been supplied with a WARNING TAG from the factory.

Secure WARNING TAG (A14) to bonnet (A6) with one of the bonnet screws (A8) at the location noted during disassembly.

8. Turn the plug (A3) to the closed position. See "Actuator Stop Adjustments" section.
9. For valves with low friction packing, lubricate the new packing (A9), then install it one ring at a time. See Figure 4.
Note: 3 - 8" valves use a friction cone (A21) with a wrenching nut or hand lever actuator, and standard packing. Before installing the gland (A11), set the friction cone on top of the packing (A9). Do not lubricate the outside of the friction cone or the inside of the gland. (See Figure 5.)
10. Slide the gland (A11) down the plug shaft (A3) and over the studs (A12). If the valve has a friction cone (A21), bring the gland nuts (A13) under the gland up finger tight.
11. Adjust gland nuts (A13).

3 - 8" LEVER AND NUT OPERATED VALVES ONLY:

Turn packing gland nuts (A13) onto the studs (A12) until they contact the gland (A11). It will be necessary to adjust the gland nuts after the valve is pressurized; see the "Packing Adjustment" section.

Note: This is a preliminary adjustment, it will be necessary to adjust the gland nuts (A13) after the valve is pressurized. See "Packing Adjustment" section.

DeZURIK

3-36" PEF 100% Port Eccentric Plug Valves

Reassembly (Continued)

12. Install the actuator—see Actuator Instructions.
13. After actuator is mounted, and shaft key is assembled in keyseat, secure shaft key by staking with a center-punch on the end of the shaft. Stake on both sides of the shaft as shown in Figure 7.

Note: Do not deform the outside diameter of the shaft.

14. After pipeline flow is restored, check the packing for leakage.

Note: If packing leaks, tighten the gland nuts (A13) only enough to stop the leak. Over tightening the packing will cause premature packing failure and higher valve operating torque.

15. If the actuator is a powered actuator, reconnect power to the actuator.

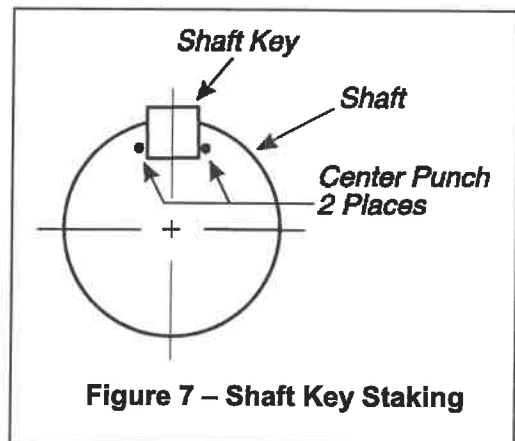

Figure 7 – Shaft Key Staking

Removing Valve from Pipeline

To remove the entire valve assembly from the pipeline, follow these steps.



WARNING!

This valve is a pressure vessel. The bonnet will blow off the valve if the bonnet bolts are removed with pressure in the valve and pipeline media can be hazardous.

Completely release pressure before disassembling the valve.

1. Relieve pipeline pressure and drain portion of system where valve is located.
2. Close the valve.



WARNING!

Moving parts from accidental operation of power actuator can cause personal injury or equipment damage. Disconnect and lock out power to actuator before servicing.

3. If the actuator is powered, disconnect and lock out the pneumatic, hydraulic, or electrical power to prevent accidental operation of the actuator.
4. Support the valve assembly, then remove the flange bolts.
5. Remove the valve from the pipeline.

Field Test

Stroke the valve between the fully open and fully closed positions to verify that the valve and actuator are functioning properly. Prior to any field pressure test above the valve design pressure, contact DeZURIK.



WARNING!

Test pressures above valve design pressure can cause leakage, permanent or structural failure to the valve and personal injury.

Valve Exercising

Each valve should be operated through a full cycle and returned to its normal operating position on a time schedule that is designed to prevent a buildup of media deposits that could render the valve inoperable or prevent a tight shutoff.

The interval of time between exercising valves in critical applications or valves subjected to severe operating conditions, should be shorter than valves in less critical installations. The time period for valve exercising should be based on local experience.

Emergency Operation

Operate the valve as under normal conditions, taking care to bring the plug to the position required by the particular emergency condition.

Predicted Wear of Parts

Length of service for parts subject to wear is dependent on service conditions.

Troubleshooting

Symptom	Possible Cause	Corrective Action
Packing Leaks.	Packing is loose.	Adjust Packing. (See "Packing Adjustment" section.)
	Packing is worn.	Replace Packing. (See "Packing Replacement" section.)
Valve does not close.	Object is wedged between plug and seat.	Open the valve completely to flush object. If this doesn't work, remove valve from the pipeline or drop one section of adjacent pipe. (See "Removing Valve from Pipeline" section.)
	Actuator closed position is out of adjustment.	Adjust the closed position stop as described in the Actuator instructions.
Valve leaks when closed	Plug is worn or damaged.	Replace plug. (See "Disassembly" section.)
	Rubber on plug is torn.	



DeZURIK MANUAL
G-SERIES ACTUATOR
USED ON PEF 100% PORT PLUG VALVES

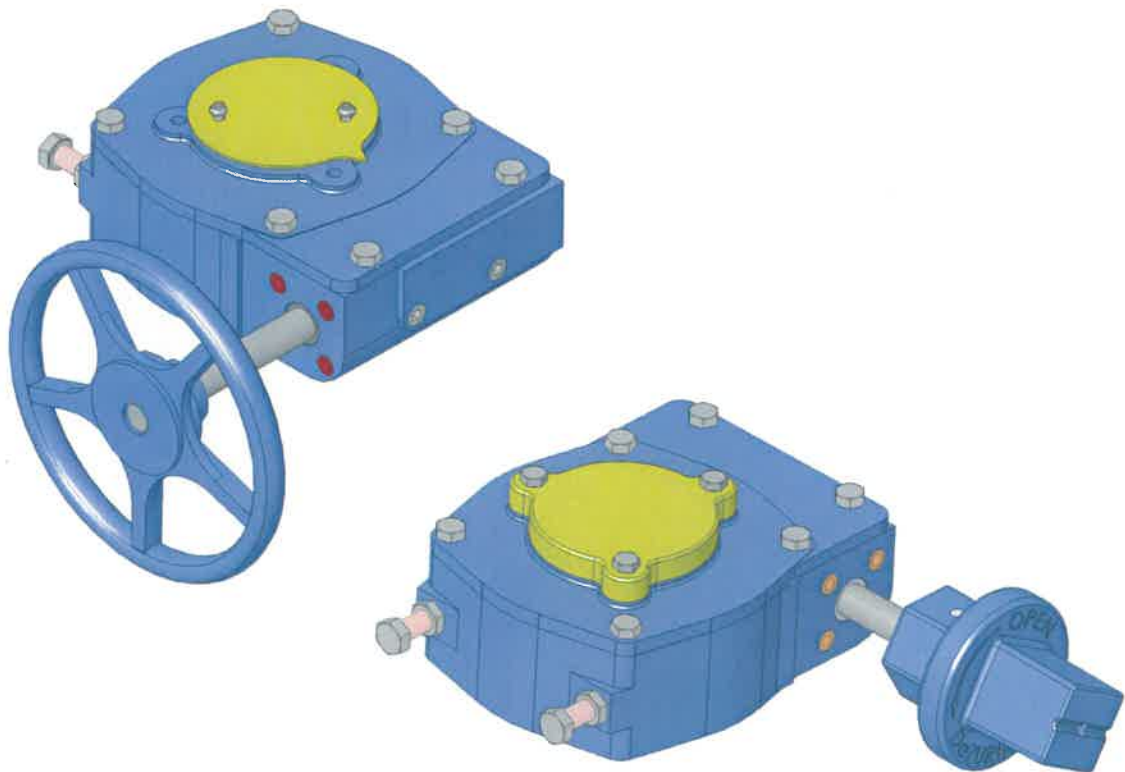

Instruction **D10456**
August 2012

DeZURIK

Manual G-Series Actuator used on PEF 100% Port Plug Valves

Instructions

These instructions provide information about Manual G-Series Actuators on PEF 100% Port Eccentric Plug Valves. They are for use by personnel who are responsible for installation, operation and maintenance of Manual G-Series Actuators.

Safety Messages

All safety messages in the instructions are flagged with an exclamation symbol and the word Caution, Warning or Danger. These messages indicate procedures that must be followed exactly to avoid equipment damage, personal injury or death.

Safety label(s) on the product indicate hazards that can cause equipment damage, personal injury or death. If a safety label becomes difficult to see or read, or if a label has been removed, please contact DeZURIK for replacement label(s).



WARNING!

Personnel involved in the installation or maintenance of valves should be constantly alert to potential emission of pipeline material and take appropriate safety precautions. Always wear suitable protection when dealing with hazardous pipeline materials. Handle valves, which have been removed from service with suitable protection for any potential pipeline material in the valve.

Inspection

Your Manual G-Series Actuator has been packaged to provide protection during shipment; however, it can be damaged in transport. Carefully inspect the unit for damage upon arrival and file a claim with the carrier if damage is apparent.

Parts

Recommended spare parts are listed on the assembly drawing. These parts should be stocked to minimize downtime.

Order parts from your local DeZURIK sales representative, or directly from DeZURIK. When ordering parts, please include the 7-digit part number and 4-digit revision number (example: **9999999R000**) located on the data plate attached to the valve assembly. Also include the part name, the assembly drawing number, the balloon number and the quantity stated on the assembly drawing.

DeZURIK Service

DeZURIK service personnel are available to install, maintain and repair all DeZURIK products. DeZURIK also offers customized training programs and consultation services.

For more information, contact your local DeZURIK sales representative or visit our website at www.dezurik.com.

Table of Contents

Description	4
Operation	4
Tools Required	4
Lubrication	4
Parts Identification	5
Stop Adjustments	6
To Adjust the Closed Position Stop	6
To Adjust the Open Position Stop	7
Removing Actuator from Valve	9
Replacing Actuator on Valve	10
Changing Actuator Mounting Position	10
Actuator Disassembly and Assembly	11
Actuator Disassembly	11
Actuator Assembly	12
Operator Component Identification	13
Replacing Handwheel or Wrenching Square with Chainwheel	14
G_-6A and G_-12A (3" - 12" valves)	14
G_-12A (14" - 20" valves)	14
Replacing Chainwheel with Handwheel or Wrenching Square	15
Troubleshooting	16

DeZURIK

Manual G-Series Actuators used on PEF 100% Port Plug Valves

Description

The manual operated G-Series actuator is designed to operate a PEF 100% Port Eccentric plug valve. External adjustable stops limit actuator stroke for both the open and closed valve positions. This actuator is available in two sizes: Size 6 and Size 12. See Figure 1 to identify which unit you have.

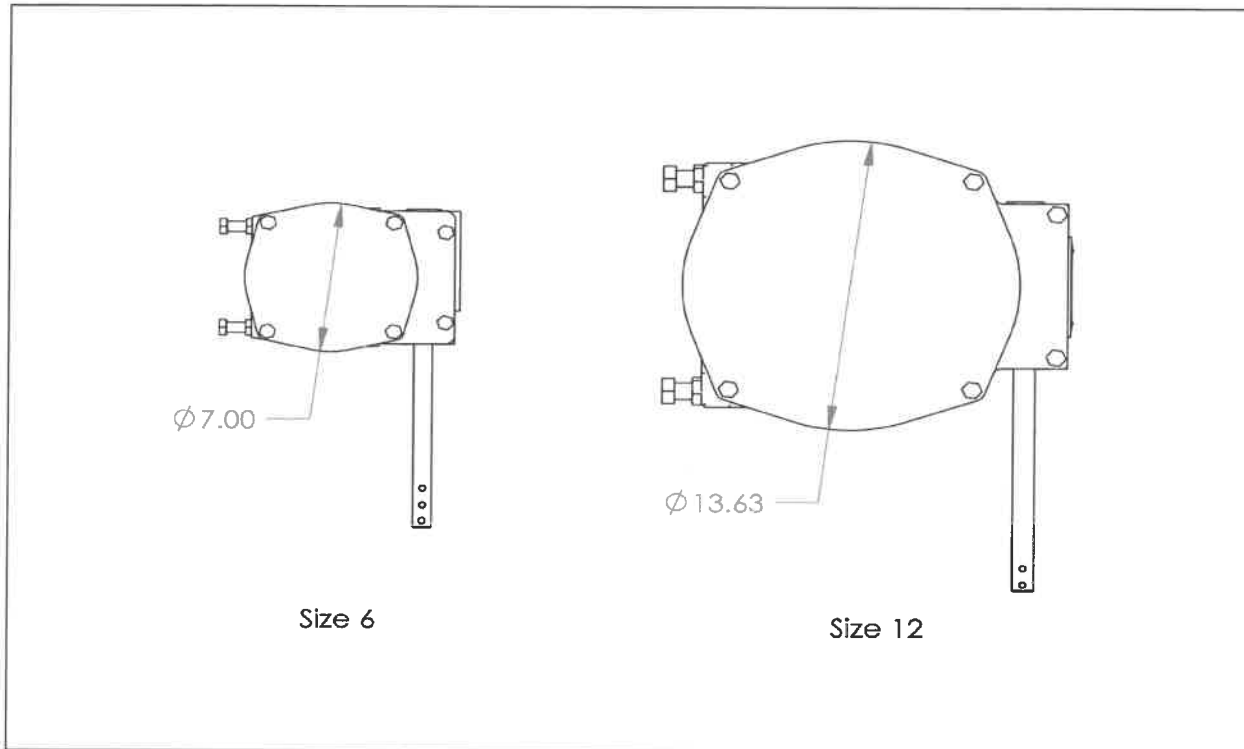

Figure 1— G-Series Actuator Identification

Operation

Rotating the operator (handwheel, chainwheel or 2" nut) clockwise closes the valve. Counterclockwise rotation of the operator opens the valve. To actuate the valve from full open to full closed (or vice-versa), the Size 6 requires 13 revolutions and the Size 12 requires 19 revolutions of the operator.

Tools Required

This actuator is assembled using metric fasteners. To service this unit, you should have a full set of combination or ratchet wrenches, Allen wrenches, flat tipped screwdrivers, a 1/4" pin punch and a dead blow hammer.

Lubrication

The G-Series actuator has been lubricated at the factory and requires no routine maintenance lubrication. If the actuator requires disassembly, see the ACTUATOR DISASSEMBLY AND ASSEMBLY section in this instruction for disassembly, lubrication and assembly procedures.

Parts Identification

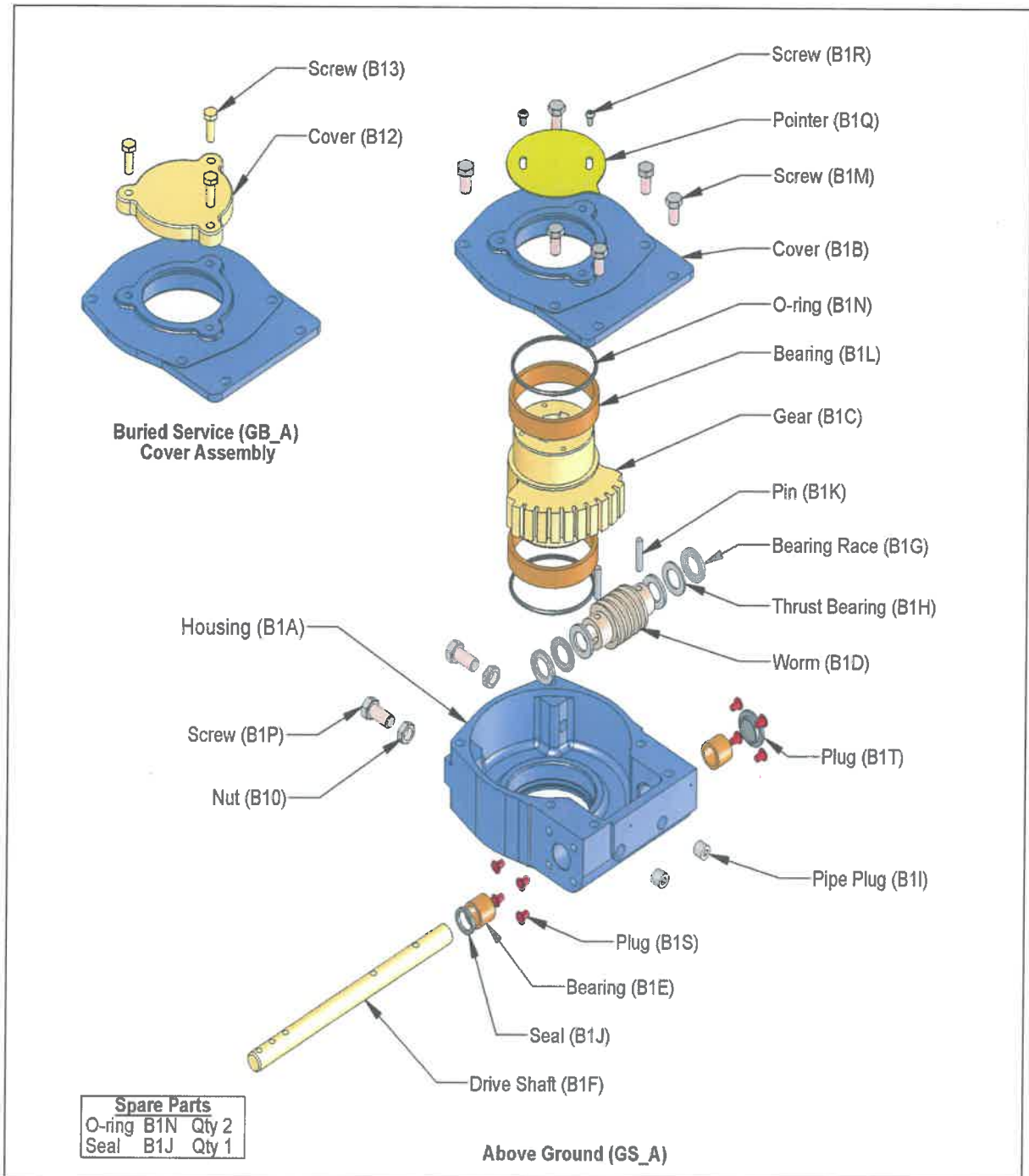

Figure 2— Actuator Parts Identification

DeZURIK

Manual G-Series Actuators used on PEF 100% Port Plug Valves

Stop Adjustments

The open and closed position stops prevent the valve plug from rotating beyond the optimum open and shutoff positions.

If the actuator is factory-mounted on the valve, the stops are preset, and do not require further adjustment. If the actuator is not factory mounted on the valve, or if the actuator has been removed, the stops will require adjustment as described below; also refer to the Valve Instructions for specific closed position requirements for the valve.

Valves can be mounted with Direct or Reverse pressure.

Direct Pressure - When the higher pressure is at the end opposite the seat. See Figure 3.

Reverse Pressure - When the higher pressure is at the seat end of the valve. See Figure 3.

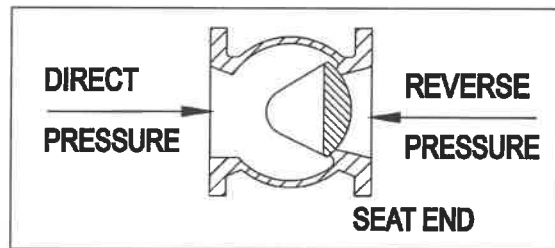

Figure 3— Pressure Direction

To Adjust the Closed Position Stop

See Figure 5 for stop Identification.



WARNING!

To adjust the closed position stop: (see Figure 5 for stop identification) Adjusting stops with flow in the pipeline can allow the valve to close causing personal injury and damaging the flow system.

Shut down the flow and relieve pipeline pressure before making stop adjustments

1. Discontinue flow and relieve pipeline pressure.
2. Close the valve.
3. Loosen the nut on the closed position screw, and back out the screw about two turns.
4. Turn the handwheel, chainwheel or 2" wrenching square operator until the specified Actuator Input Torque from Table A is reached.
5. While maintaining the Actuator Input Torque from Table A, turn the closed position screw clockwise until resistance is felt from the screw contacting the gear (B1C).
6. Prevent the screw from turning and tighten the nut against housing (B1A).
7. Pipeline flow may now be restored.

Stop Adjustments *(Continued)*

To Adjust the Open Position Stop

See Figure 5 for stop identification.



WARNING!

Adjusting stops with flow in the pipeline can allow the valve to close causing personal injury and damaging the flow system.

Shut down the flow and relieve pipeline pressure before making stop adjustments.

1. Discontinue flow and relieve pipeline pressure.
2. To visually determine when the valve is in the open position:
Above Ground Service (GS_A) actuator - Remove the screws (B1R) and pointer (B1Q).
Buried Service (GB_A) actuator - Remove the screws (B13) and cover (B12).
3. Loosen the nut on the open position screw, and back out the screw about two turns.
4. Turn the handwheel, chainwheel or 2" wrenching square operator so the drive key/plug alignment is parallel to the valve flanges. See Figure 4 for valve open position.

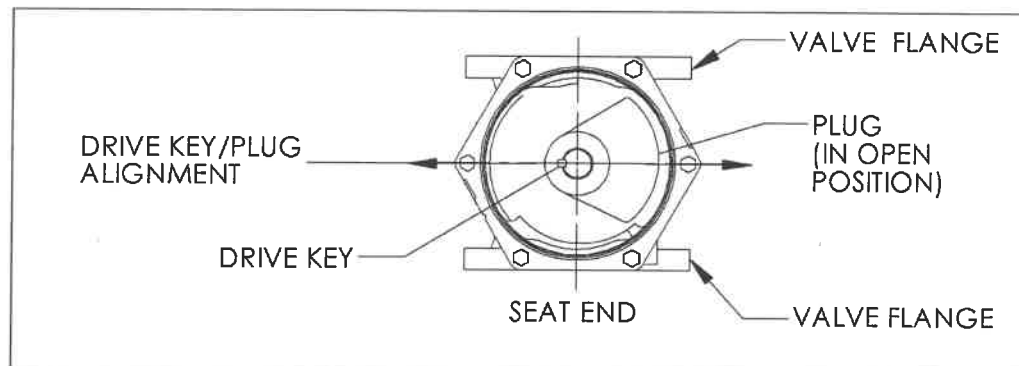

Figure 4— Valve Open Position

5. Turn the open position screw clockwise until resistance is felt from the screw contacting the gear (B1C).
6. Prevent the screw from turning, and tighten the nut against housing (B1A).
7. **Above Ground Service (GS_A) actuator** - Replace the pointer (B1Q) so it is pointing at the OPEN mark on the cover (B1B) and tighten screws (B1R).
Buried Service (GB_A) actuator - Remove old sealant from cover (B12) and cover (B1B) mating mounting surfaces. Apply a bead of silicone sealant DOW RTV-732 (1055515) or similar to the cover (B12) and cover (B1B) mating surfaces. Fasten the cover (B12) to cover (B1B) with screws (B13).
8. Pipeline flow may now be restored.

DeZURIK

Manual G-Series Actuators used on PEF 100% Port Plug Valves

Stop Adjustments *(Continued)*

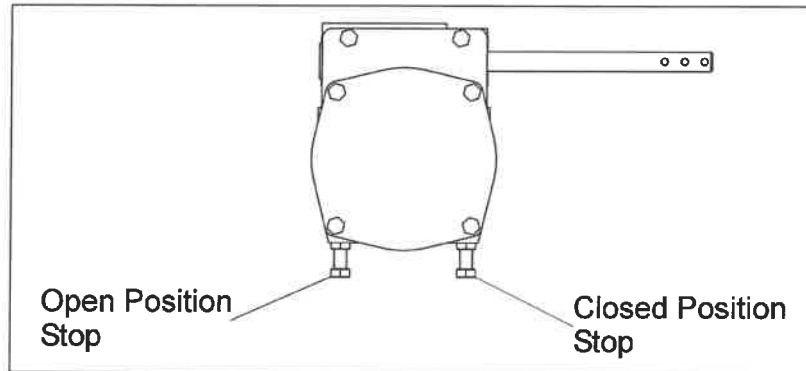

Figure 5— Open and Closed Position Stop Identification

Valve Size	Actuator Size	Actuator Input Torque (ft-lbs)							
		Direct Pressure Drop (psi)	Reverse Pressure Drop (psi)						
			25	50	75	100	125	150	175
3 & 4	G6	4	4	4	5	5	5	5	5
5	G6	8	8	9	10	11	11	11	11
6	G6	8	8	9	10	11	11	11	11
8	G6	15	15	17	19	20	21	21	21
10	G6	22	22	25	29	33	36	N/A	N/A
10	G12	11	11	18	18	18	18	18	18
12	G6	29	29	29	29	N/A	N/A	N/A	N/A
12	G12	15	15	15	15	15	15	15	15
14	G12	18	18	24	29	34	34	34	N/A
16	G12	22	22	29	37	45	45	45	N/A
18	G12	26	26	35	45	55	55	N/A	N/A
20	G12	29	29	44	55	55	N/A	N/A	N/A

Note: The "N/A" designation in Table A indicates that the Valve/Actuator combination cannot be used for that particular reverse pressure.

Removing Actuator from Valve

Refer to Figure 6 for connecting parts identification.

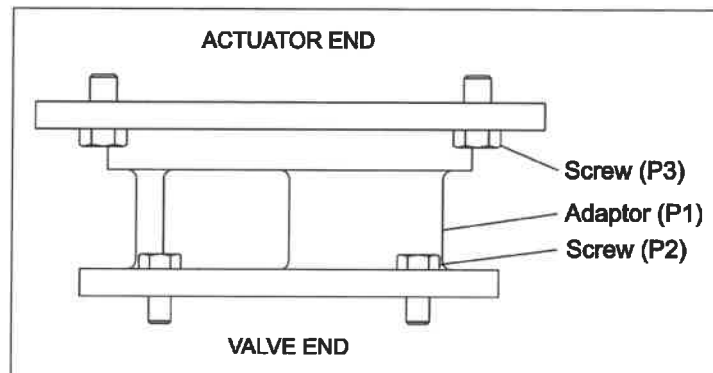

Figure 6— Connecting Parts Identification



WARNING!

Flow in the pipeline with the actuator removed can slam the valve closed causing personal injury and damaging the flow system. Shut down the flow in the pipeline before removing the actuator from the valve.

1. Discontinue flow and relieve pipeline pressure.



WARNING!

When Eccentric Plug valves are mounted in a vertical pipeline, or mounted in a horizontal pipeline with the plug stem horizontal, there is a chance that gravity will cause the plug to swing to a lower position in the valve body when the actuator is removed.

To avoid this hazard, rotate the plug to the lowest position before removing the actuator.

2. Close the valve or rotate the plug to the lowest position in the valve body.
3. Remove the four adaptor mounting screws (P3).
4. Remove the actuator from the adaptor (P1).
5. Do not loose the drive key used in the valve plug and actuator gear.

DeZURIK

Manual G-Series Actuators used on PEF 100% Port Plug Valves

Replacing Actuator on Valve

Refer to Figure 2 and Figure 6 for parts identification.

1. Place the valve in the position it was in when the actuator was removed. Normally this will be so the plug is in the lowest position in the valve body.
2. **For Buried Service (GB_A) actuators only** - Before reassembly, remove old sealant from all mating mounting surfaces. Apply a thin bead of silicone sealant DOW RTV-732 (1055515) or similar to the adaptor (P1) and the actuator housing (B1A) mounting surfaces.
3. **Above Ground Service (GS_A) actuator only** - Remove the screws (B1R) and pointer (B1Q).
Buried Service (GB_A) actuator only - Remove the screws (B13) and cover (B12).
4. Mount the actuator to the adaptor with the four mounting screws (P3). Tighten screws.
5. Insert the drive key into the valve plug/gear (B1C) keyway.
6. **Above Ground Service (GS_A) actuator only** - Fasten the pointer (B1Q) to the gear (B1C) with the two screws (B1R).
Buried Service (GB_A) actuator only - Remove old sealant from cover (B12) and cover (B1B) mating mounting surfaces. Apply a bead of silicone sealant DOW RTV-732 (1055515) or similar to the cover (B12) and cover (B1B) mating surfaces. Fasten the cover (B12) to cover (B1B) with screws (B13).
7. Check the closed position stop setting and readjust if necessary as described in the "STOP ADJUSTMENT" Section of this Instruction.
8. Pipeline flow may now be restored.

Changing Actuator Mounting Position

The actuator can be mounted in 90° increments around the valve shaft.

To move the actuator mounting position in 90° increments from its present position, follow these steps.

1. Remove the actuator from the valve as described in the REMOVING ACTUATOR FROM VALVE Section of this Instruction.
2. Rotate the actuator to the desired position.
3. Install the actuator on the valve as described in the REPLACING ACTUATOR ON VALVE Section of this Instruction.

Actuator Disassembly and Assembly

Under normal operating conditions the G-Series actuator does not require routine maintenance. If the actuator has excessive wear or has been damaged, it is recommended that the actuator be replaced, not repaired.

Use the following procedure for replacing leaking seals and o-rings. Refer to Figure 2 for component identification.

Actuator Disassembly



WARNING!

Flow in the pipeline with the actuator removed can slam the valve closed causing personal injury and damaging the flow system. Shut down the flow in the pipeline before removing the actuator from the valve.

1. Discontinue flow and relieve pipeline pressure.
-



WARNING!

When Eccentric Plug valves are mounted in a vertical pipeline, or mounted in a horizontal pipeline with the plug stem horizontal, there is a chance that gravity will cause the plug to swing to a lower position in the valve body when the actuator is removed.

To avoid this hazard, rotate the plug to the lowest position before removing the actuator.

2. Close the valve or rotate the plug to the lowest position in the valve body.
3. Remove the actuator from the valve as described in the REMOVING ACTUATOR FROM VALVE Section of this Instruction.
4. **Above Ground Service (GS_A) actuator only** - Note the position of the pointer (B1Q), then remove the screws (B1R) and pointer.
Buried Service (GB_A) actuator only - Remove screws (B13) and cover (B12).
5. Remove the screws (B1M) and cover (B1B).
6. Remove the o-ring (B1N) thru the top of the cover (B1B).
7. Note the position of the gear (B1C) in the housing (B1A), then slide the gear (B1C) out of the housing.
8. Remove the two pipe plugs (B1I) from the housing (B1A).
9. Rotate the drive shaft (B1F) until the pins (B1K) line up with the pipe plug holes in the housing (B1A).

DeZURIK

Manual G-Series Actuators used on PEF 100% Port Plug Valves

Actuator Disassembly and Assembly *(Continued)*

10. Drive both pins (B1K) thru the worm (B1D) and drive shaft (B1F).
11. Slide the drive shaft (B1F) out of the housing (B1A).
12. Remove the seal (B1J) from the housing (B1A).
13. Remove the o-ring (B1N) thru the bottom of the housing (B1A).
14. Remove old gasket sealant from the top of the housing (B1A) and bottom of the cover (B1B).

Buried Service (GB_A) actuator only - Remove old gasket sealant from the bottom of the housing (B1A), valve adaptor (P1), top of cover (B1B) and bottom of cover (B12) mating surfaces.

Actuator Assembly

1. Install a new seal (B1J) into the housing (B1A).
2. Slide the drive shaft (B1F) into the housing (B1A) and thru bearing race (B1G), thrust bearing (B1H), bearing race (B1G), worm (B1D), bearing race (B1G), thrust bearing (B1H) and bearing race (B1G).
3. Rotate the drive shaft (B1F) until the pin holes in the drive shaft and the worm (B1D) line up.
4. Drive the two pins (B1K) thru the worm (B1D) and drive shaft (B1F).
5. Apply removable thread sealant to the threads of pipe plugs (B1I) and install the pipe plugs flush or below the surface of the housing (B1A).
6. Apply a light film of grease to a new o-ring (B1N) and insert it into the groove in the bottom of the housing (B1A).
7. Grease the bearing (B1L) in the housing (B1A) and slide the gear (B1C) into the bearing in the position noted in Step 7 of the ACTUATOR DISASSEMBLY section.
8. **Above Ground Service (GS_A) actuator only** - Apply a liberal amount of Lithium based grease such as Shell Alvania EP2 or Mobilux EP2 to the gear (B1C), bearings (B1L) and worm (B1D).
Buried Service (GB_A) actuator only - Pack the housing (B1) full of Lithium based grease such as Shell Alvania EP2 or Mobilux EP2.
9. Apply a light film of grease to a new o-ring (B1N) and insert into groove in the cover (B1B).
10. Apply a bead of silicone sealant DOW RTV-732 (1055515) or similar to the housing (B1A) or cover (B1B) mating surface. Grease the bearing (B1L) in the cover, slide the cover onto the gear (B1C) and fasten with screws (B1M) to the housing.
11. Insert the drive key into the valve plug/gear (B1C) keyway.
12. **Above Ground Service (GS_A) actuator only** - Fasten the pointer (B1Q) to the gear (B1C) with the two screws (B1R) in the position noted in Step 4. of the ACTUATOR DISASSEMBLY section.
Buried Service (GB_A) actuator only - Apply a bead of silicone sealant DOW RTV-732 (1055515) or similar to the cover (B12) or cover (B1B) mating surface. Fasten the cover (B12) to cover (B1B) with screws (B13).
13. Install the actuator on the valve as described in the "REPLACING ACTUATOR ON VALVE" section of this Instruction.

DeZURIK
Manual G-Series Actuators used on
PEF 100% Port Plug Valves

Operator Component Identification

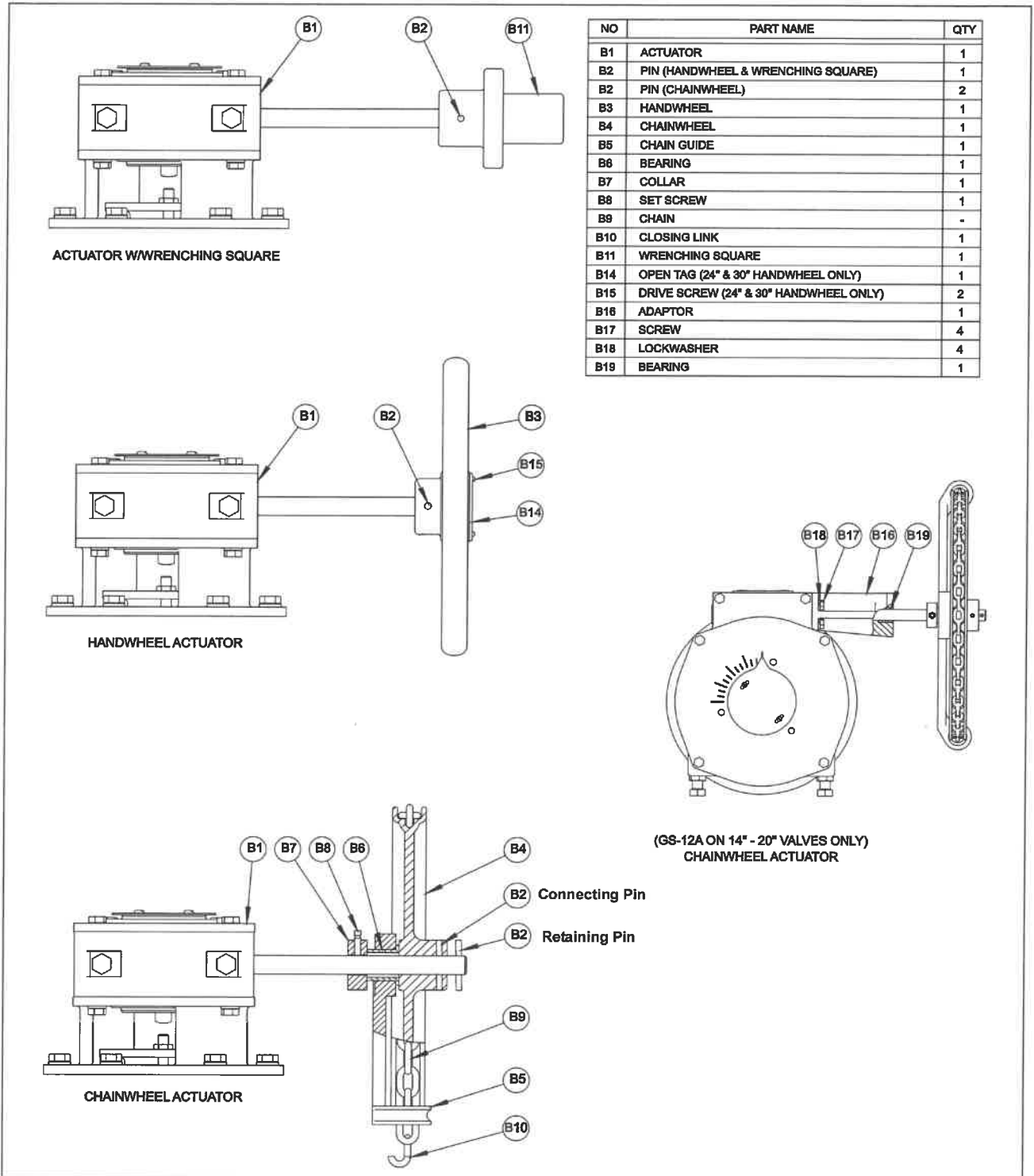

Figure 7— Operator Component Identification

DeZURIK

Manual G-Series Actuators used on PEF 100% Port Plug Valves

Replacing Handwheel or Wrenching Square with Chainwheel

Refer to Figure 7 for component identification.

G_-6A and G_-12A (3" - 12" valves)

1. Support the actuator shaft with a solid surface, drive out the pin (B2), and remove the handwheel (B3) or wrenching square (B11) from the actuator shaft.
2. Slide the collar (B7) onto the actuator shaft
3. Assemble the bearing (B6), chain guide (B5) and the chainwheel (B4) onto the actuator shaft.
4. Align the second pin hole in the actuator shaft and the pin hole in the chainwheel hub. Support the hub of the chainwheel with a solid surface and drive the connecting pin (B2) into position. See Figure 7 for location of connecting pin.



WARNING!

The connecting pin securing the chainwheel hub to the actuator shaft could potentially shear allowing the chainwheel to disengage from the actuator shaft and cause personal injury or equipment damage.

A retaining pin at the end of the actuator shaft must be in-place to insure the chainwheel can not disengage from the actuator shaft.

5. Support the hub of the chainwheel with a solid surface and drive the retaining pin (B2) into the remaining pin hole at the end of the actuator shaft. See Figure 7 for location of retaining pin.
6. Slide the collar (B7) up to the bearing (B6) and tighten with set screw (B8).
7. Feed the chain (B9) over the chainwheel (B4) and through both openings in the chain guide (B5).
8. Connect the ends of the chain (B9) with closing link (B10).

G_-12A (14" - 20" valves)

1. Support the actuator shaft with a solid surface, drive out the pin (B2), and remove the handwheel (B3) or wrenching square (B11) from the actuator shaft.
2. Remove the plastic plugs from the mounting holes on the shaft side of the actuator housing.
3. Slide the adaptor (B16) onto the actuator shaft. Tighten with screws (B17) and lockwashers (B18).
4. Slide the collar (B7) onto the actuator shaft
5. Assemble the bearing (B6), chain guide (B5) and the chainwheel (B4) onto the actuator shaft.

Replacing Handwheel or Wrenching Square with Chainwheel *(Continued)*

6. Align the second pin hole in the actuator shaft and the pin hole in the chainwheel hub. Support the hub of the chainwheel with a solid surface and drive the connecting pin (B2) into position. See Figure 7 for location of connecting pin.



WARNING!

The connecting pin securing the chainwheel hub to the actuator shaft could potentially shear allowing the chainwheel to disengage from the actuator shaft and cause personal injury or equipment damage.

A retaining pin at the end of the actuator shaft must be in-place to insure the chainwheel can not disengage from the actuator shaft.

7. Support the hub of the chainwheel with a solid surface and drive the retaining pin (B2) into the remaining pin hole at the end of the actuator shaft.
8. Slide the collar (B7) up to the bearing (B6) and tighten with set screw (B8).
9. Feed the chain (B9) over the chainwheel (B4) and through both openings in the chain guide (B5).
10. Connect the ends of the chain (B9) with closing link (B10).

Replacing Chainwheel with Handwheel or Wrenching Square

Refer to Figure 7 for component identification.

1. Support the chainwheel hub with a solid surface and drive out the two pins (B2).
2. Remove the chainwheel (B4) and chain guide (B5) assembly from the actuator shaft.
3. Loosen the set screw (B8) and slide the collar (B7) off the actuator shaft.
4. **GS-12A on 14" - 20" valves only** - Remove screws (B17), lockwashers (B18) and slide adaptor (B16) off the actuator shaft.
5. Slide the handwheel (B3) or wrenching square (B11) onto the actuator shaft. Align the pin hole in the handwheel or wrenching square with the second pin hole in the actuator shaft. Support the actuator shaft with a solid surface and drive the pin (B2) into position.

DeZURIK

Manual G-Series Actuators used on PEF 100% Port Plug Valves

Troubleshooting

Condition	Possible Cause	Corrective Action
Actuator closes to wrong position.	Closed position stop is set incorrectly.	Adjust closed position stop. See STOP ADJUSTMENTS section.
	Pointer is installed incorrectly.	Rotate pointer to correct position.
Actuator opens to wrong position.	Open position stop is set incorrectly.	Adjust closed position stop. See STOP ADJUSTMENTS section.
	Pointer is installed incorrectly.	Rotate pointer to correct position.
Actuator will not fully operate valve.	Pipeline obstruction in valve is preventing closure.	Remove obstruction.
High operating torque.	Misalignment of adaptor.	Check valve-adaptor actuator alignment and adjust.
	Misalignment of ENK extension.	Check valve-extension-actuator alignment and adjust.
	Bent actuator input shaft.	Replace actuator.



DeZURIK
2-24" (50-600mm)
KGC ES or HD
KNIFE GATE VALVES

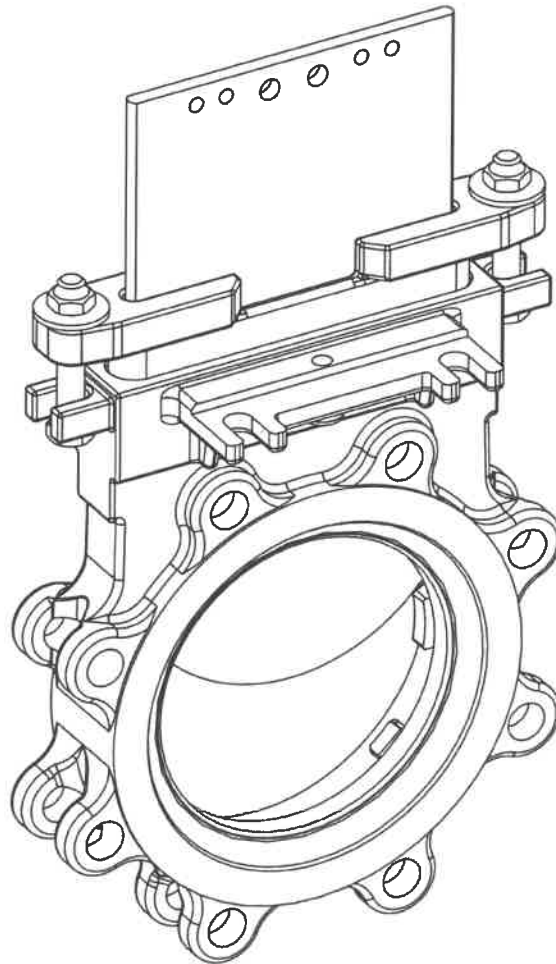

Instruction **D10411**
July 2018

DeZURIK

2-24" KGC ES or HD KNIFE GATE VALVES

Instructions

These instructions are intended for personnel who are responsible for the installation, operation and maintenance of your KGC knife gate valve, including models KGC-ES, KGC-HD, KGC-GV, KGC-MV and KGC-SV in sizes 2-24".

Safety Messages

All safety messages in the instructions are flagged with the word Caution, Warning or Danger. These messages must be followed exactly to avoid equipment damage, personal injury or death.

Safety label(s) on the product indicate hazards that can cause equipment damage, personal injury or death. If a safety label becomes difficult to see, or if a label has been removed, please contact DeZURIK for replacement.



WARNING

Personnel involved in the installation or maintenance of valves should be constantly alert to potential emission of process material and take appropriate safety precautions. Always wear suitable protection when dealing with hazardous process materials. Handle valves which have been removed from service with the assumption of process material within the valve.

Inspection

Your KGC knife gate valve has been packaged to provide protection during shipment. Carefully inspect the unit for damage upon arrival and file a claim with the carrier if damage is apparent.

Parts

Recommended spare parts are listed on the assembly drawing. These parts should be stocked to minimize downtime.

Order parts from your DeZURIK sales representative, or directly from DeZURIK. When ordering parts, please include the 7-digit part number and 4-digit revision number (example: **9999999R000**) located on the data plate attached to the valve assembly. Also include the part name, the assembly drawing number, the balloon number and the quantity stated on the assembly drawing.

DeZURIK Service

DeZURIK Service personnel are available to install, maintain and repair all DeZURIK products. DeZURIK also offers customized training programs and consultation services. For more information, contact your local DeZURIK representative or visit our website at www.dezurik.com.

DeZURIK

2-24" KGC ES or HD KNIFE GATE VALVES

Table of Contents

Description	4
Handling	4
Installation	6
Operation	7
Lubrication	7
Packing	7
Adjustment	7
Drawings	8
Packing Replacement	9
<i>Removing the Old Packing</i>	9
<hr/>	
<i>Installing the New Packing</i>	10
<i>Reassembling the Valve</i>	11
Seat Replacement	11
<i>Reassembling the Valve</i>	12
Replacing the Gate	12
Purge Port Option	13
Troubleshooting	15

DeZURIK

2-24" KGC ES or HD KNIFE GATE VALVES

Description

KGC knife gate valves have a stainless steel body and gate, and an all-metal or resilient-faced seat. The KGC knife gate valve is available in 2-48" (50-1200mm) sizes. This manual covers the 2-24" (50-600mm) sizes. A choice of several actuators and accessories is available.

Handling



WARNING!

A potential hazard exists with handling valves. Failure to handle valves properly may cause a valve to shift, slip or fall causing serious injury or death and/or equipment damage.

The points below are for reference purposes only, use safe and proper lifting and support techniques. DO NOT lift valves with any adjoining pipe or other equipment attached. Lift with properly rated lifting equipment. Follow jurisdictional safety requirements.

Suggested lifting points are as shown below to lift valve assemblies that are in a horizontal orientation. Eye bolts in flange through holes can be used to lift the valve body or, for 2" through 12" valves, a sling can be strapped around the top of the valve body.

For valves with bevel gear actuators, a sling or chain can be wrapped around the bevel gear actuator body, between the mounting plate and the input shaft housing. This would be in conjunction with lifting from the valve body as well. See Figure 1.

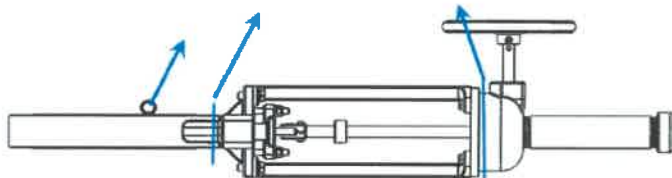

Figure 1— Knife Gate Valve with Bevel Gear Actuator, Horizontal Lifting

For valves with pneumatic cylinder actuators, a sling can be wrapped around the cylinder, near the cylinder head (piston rod end). This would be in conjunction with lifting from the valve body. Utilize caution to not bump, dent or damage the cylinder tube. DO NOT utilize the cylinder tie-rod ends to lift. See Figure 2.

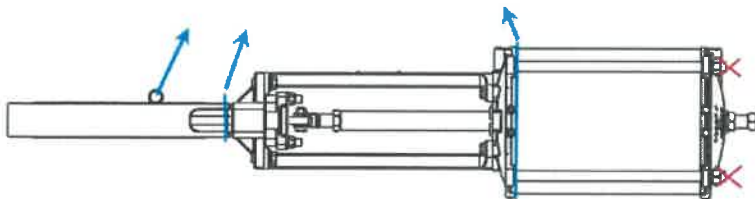

Figure 2, Knife Gate Valve with Pneumatic Cylinder Actuator, Horizontal Lifting

Handling *continued*

For valves with handwheel actuators, a sling or chain can be wrapped through the rim of the handwheel. For chainwheel actuators, a sling can be wrapped in the area between the yoke/legs and the chainwheel/guide assembly. This would be in conjunction with lifting from the valve body as well. See Figure 3.

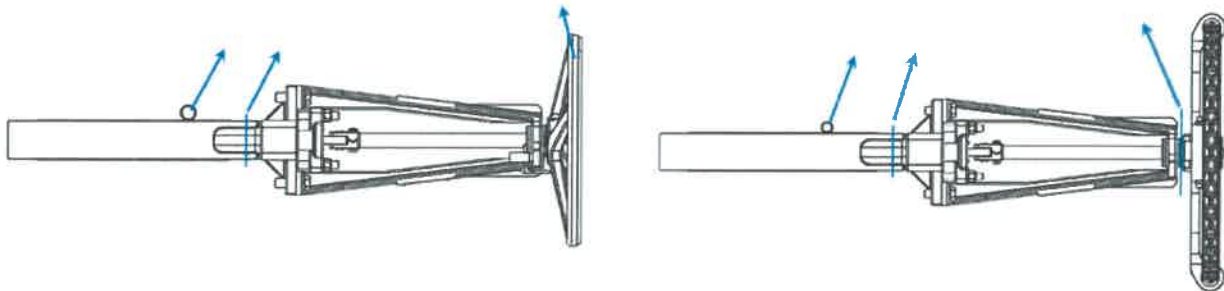

Figure 3, Knife Gate Valve with Handwheel or Chainwheel Actuator, Horizontal Lifting

Suggested lifting options are as shown below to lift valve assemblies that are in a vertical orientation. For valves with bevel gear actuators, wrap slings or chains around the top of each leg. Use caution not to put any side load on the bevel gear input shaft or on the valve's threaded stem. See Figure 4.

For valves with pneumatic cylinder actuators, wrap slings around the top of each leg. Use caution to not bump, dent or damage the cylinder tube and avoid any side load on the cylinder piston rod. DO NOT utilize the cylinder tie-rod ends to lift. See Figure 5.

For valves with handwheel or chainwheel actuators, wrap slings or chains around the top of the each leg or yoke side. Use caution to not put any side load on the valve's threaded stem. See Figure 6.

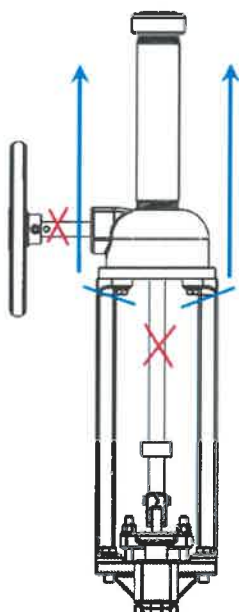

Figure 4- Knife Gate Valve with Bevel Gear Actuator, Vertical Lifting

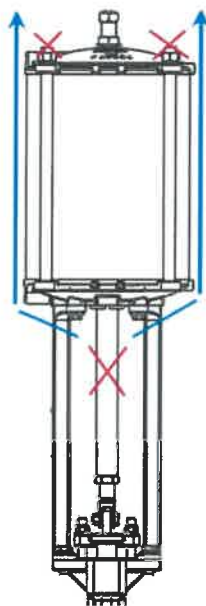

Figure 5- Knife Gate Valve with Pneumatic Cylinder Actuator, Vertical Lifting

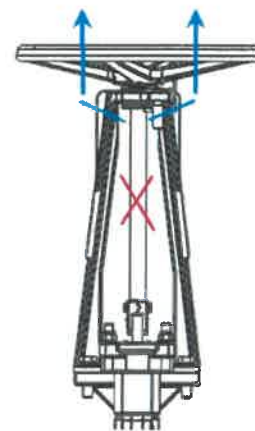

Figure 6- Knife Gate Valve with Handwheel or Chainwheel Actuator, Vertical Lifting

Installation

Install the valve between ASME Class 125 or Class 150 pipeline flanges, or other flanges that match valve end connection. Flange gaskets are required. Before installation, remove foreign material such as weld spatter, oil, grease, and dirt from the valve and pipeline.

Normal Installations

Install the valve so that the side marked "SEAT" is on the lower pressure side of the valve when the valve is closed; the pipeline pressure will then help seal the valve in the closed position.

Gravity (Dry) Service Installations

When installing the valve in a vertical pipeline (such as a hopper bottom, gravity flow, or other dry service application), install the SEAT side of the valve facing upstream as shown in Figure 1. Installing the valves with the seat side upstream prevents process media buildup in the seat and chest area of the valve. This orientation also allows the seat to act as an integral deflection cone, protecting the seat from wear.

General Guidelines

Observe the following points to prevent distortion of the valve body and gate when the flange bolts are tightened:

- Align the mating pipeline flanges.
- Select the length of the flange bolts so that the bolts used in the blind holes near the chest area of the valve do not bottom out when tightened. We recommend using studs with nuts in the blind holes.
- Tighten the flange bolts evenly, in a crisscross pattern. Refer to Table A for recommended flange bolt/stud torques.

Note: Torque ranges are based on ASME Pressure Vessel Code Calculations and lab test data. These torques are only for the listed gasket types. For other gasket types listed in ASME, consult DeZURIK.

After installing the valve, pressurize pipeline and ensure the packing is not leaking. If the packing leaks, adjust the packing as described on the next page.

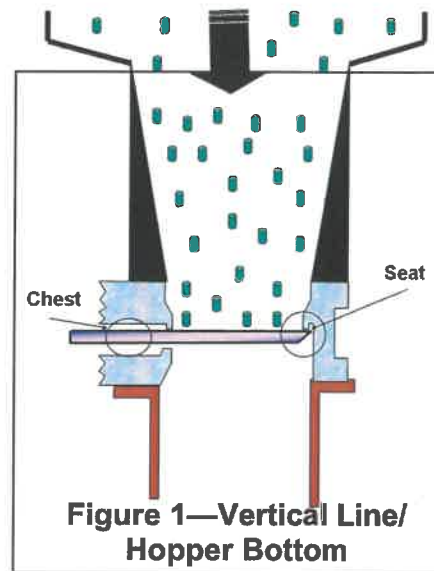

Figure 1—Vertical Line/
Hopper Bottom

Table A: Recommended Flange Bolt/Stud Torque Range in ft-lbs (non-lubricated)

Valve Size	ASME Gasket Types	
	Rubber with Soft Fabric Filler, & 1/8" Thick Hard	Soft Elastomer Gasket Shore Durometer < 75A
2" (50mm)	26 - 29	8 - 9
3" (80mm)	37 - 41	14 - 16
4" (100mm)	26 - 29	11 - 12
6" (150mm)	41 - 45	22 - 24
8" (200mm)	55 - 61	35 - 39
10" (250mm)	56 - 62	40 - 44
12" (300mm)	80 - 88	59 - 65
14" (350mm)	107 - 118	81 - 89
16" (400mm)	103 - 114	79 - 87
18" (450mm)	128 - 141	102 - 112
20" (500mm)	123 - 136	99 - 109
22" (550mm)	177-197	159-177
24" (600mm)	188 - 207	155 - 171

Operation

The gate in the valve is positioned by the valve actuator. The actuator moves the gate over the valve port in the closed position, and withdraws the gate from the seat in the open position. Refer to the Actuator Instructions for adjustment and maintenance requirements for the actuator.

Lubrication

The valve does not require lubrication. If applicable, ensure that valve threaded stems are maintained with proper lubrication. Refer to the Actuator Instructions for lubrication requirements for the actuator.

Packing

The gate packing is contained and compressed by the packing gland. See Figure 2 for component identification.

Note: The packing gland is slightly loosened prior to shipping. This is done to increase the life of the packing during extended storage.

Adjustment

If packing leaks, tighten the adjustment nuts on top of the packing gland. Tighten the nuts evenly and gently just enough to stop the leak. Over tightening will cause excessive operating forces, and will decrease the life of the packing.

DeZURIK
2-24" KGC ES or HD KNIFE GATE VALVES

Drawings

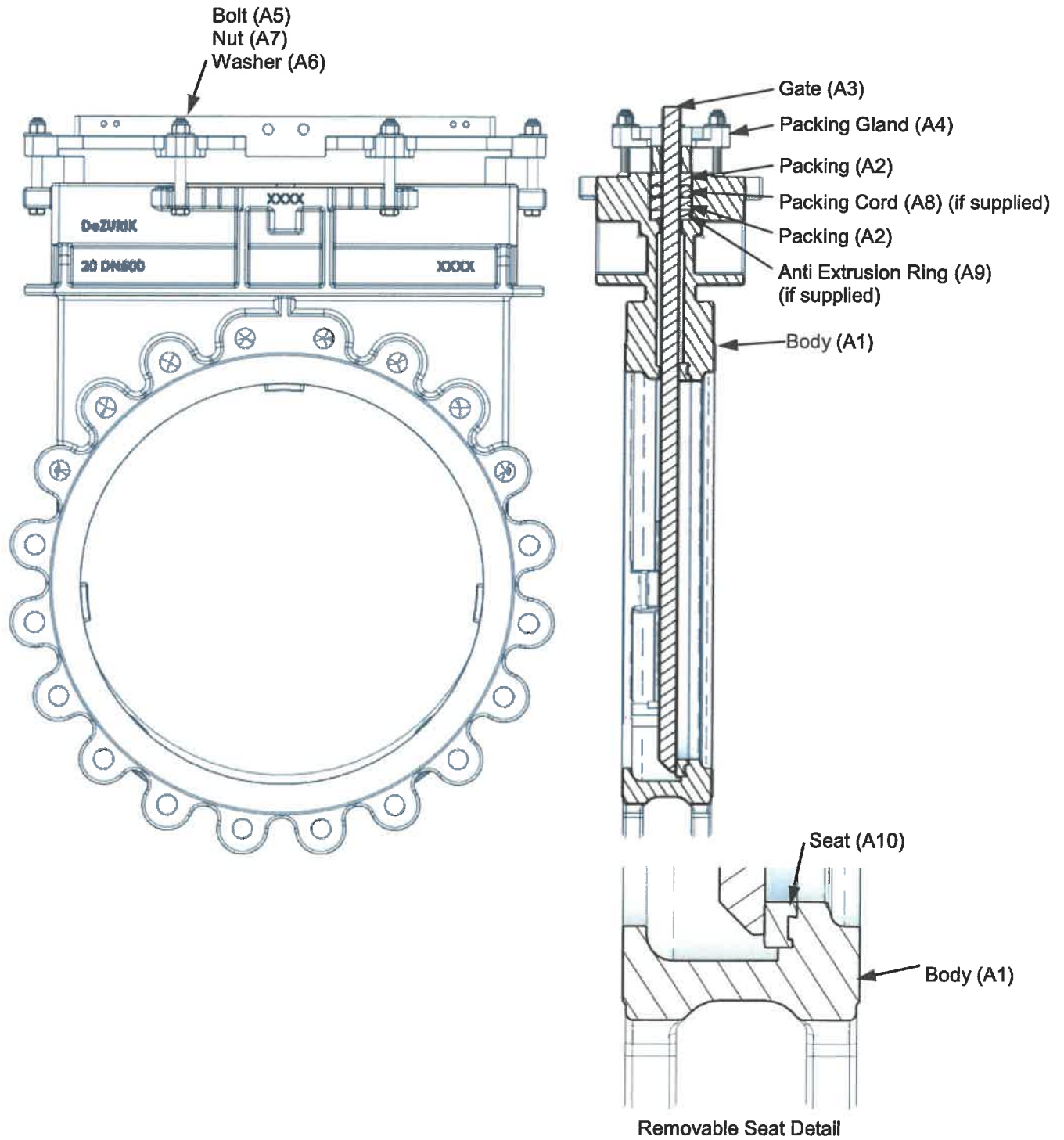

Figure 2—Component Identification

Packing Replacement

Removing the Old Packing



WARNING!

Pipeline pressure can cause personal injury or equipment damage. Relieve pipeline pressure before removing gate stem and packing gland nuts.

1. Relieve the pressure in the pipeline and close the valve.



WARNING!

Accidental operation of power actuator can cause personal injury or equipment damage. Disconnect and lock out power to actuator before servicing.

2. If the actuator is powered, disconnect and lock out power to prevent accidental operation of the actuator.
3. Remove the two screws and nuts near the top of the gate and disengage the stem from the gate by stroking the actuator (not the valve) to the open position.
4. Remove the gland nuts (A7), bolts (A5) and packing gland (A4).
5. Remove the used packing (A2), anti-extrusion ring (A9) if supplied and packing cord (A8) if supplied, from the packing chamber.

DeZURIK

2-24" KGC ES or HD KNIFE GATE VALVES

Installing the New Packing

Packing (A2) strip length and quantity are shown in Table B. Ensure the inside and outside edges of each ring are packed against the gate and packing chamber, so that each strip is compressed flat and evenly. DeZURIK provides extra packing in their packing kits, but do not try to put more packing into a layer than shown in Table B. If packing is for low pressure applications (40psi [2.7 bar]) contact DeZURIK.

Do not compress the packing any more than needed to stop leaks.

1. Ensure the gate (A3) is fully closed and centered in the body before packing.
2. If used, place the anti-extrusion ring (A9) or scraper ring in the bottom of the packing chamber.

Note: Ensure that the anti-extrusion ring fits tightly around the gate and that there is approximately 1/32-1/16" clearance around the packing chamber.

3. Assemble and pack the rings one at a time, with the ends together, but not overlapped

Note: Stagger the joints, on the long side of the packing chamber. For packing rings, we recommend using a square-ended wood or plastic tool, driven by a hammer or mallet. Do not use a sharp tool to pack the rings.

4. For packing systems with the packing cord (A8), assemble and pack one row of packing (A2) and then insert the packing cord (A8). Assemble and pack the last row of packing. See detail below:

Table B: Packing Ring and Packing Cord Length & Quantity

Valve Size	Square Size	Length, inches	Quantity	Qty Cord
2" (50mm)	3/8"	7.50	4 w/o anti-ext ring or cord	1
3" (80mm)		9.50		
4" (100mm)		11.50		
5" (125mm)		13.50		
6" (150mm)		15.50		
8" (200mm)	20.00	3 w/o cord		
10" (250mm)	1/2"		25.00	
12" (300mm)			29.00	
14" (350mm)			32.00	
16" (400mm)		36.75		
18" (450mm)	5/8"	41.25	2 with cord	
20" (500mm)		45.25		
22" (550mm)		49.11		
24" (600mm)		53.50		

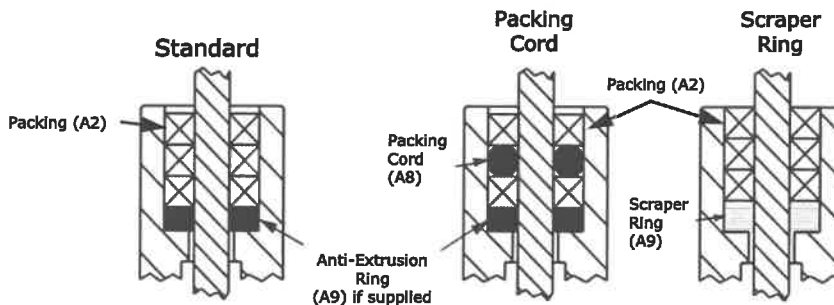

Figure 3—Packing Ring Detail

Reassembling Valve

1. Replace the packing gland (A4), bolts (A5), washer (A6) and nuts (A7). Tighten the nuts evenly and finger tight, plus 1/2 turn.
2. Reconnect the stem to the gate with the two screws and nuts.
3. If the actuator is a powered actuator, reconnect power to the actuator.
4. Pressurize the pipeline and inspect packing for leakage.
5. If packing leaks, tighten the adjustment nuts on top of the packing gland. Tighten the nuts evenly and gently - just enough to stop the leak. Over tightening will cause excessive operating forces, and will decrease the life of the packing.

Replacing the Seat

See Figure 2 for component identification.



WARNING!

Pipeline pressure can cause personal injury or equipment damage. Relieve pipeline pressure before removing gate stem and packing gland nuts.

1. Relieve the pressure in the pipeline and close the valve.



WARNING!

Accidental operation of power actuator can cause personal injury or equipment damage. Disconnect and lock out power to actuator before servicing.

2. If the actuator is powered, disconnect and lock out power to prevent accidental operation of the actuator.
3. Remove the two screws and nuts near the top of the gate and disengage the stem from the gate.
4. Remove the pipeline flange bolts and flange from the side of the valve body opposite the word "SEAT". As an alternative, remove both flanges, and remove the valve from the pipeline.
5. Remove the actuator yoke and actuator from the valve.
6. Remove the gland nuts (A7), washers (A6), and packing gland (A4).
7. Remove the gate (A3) from the body.
8. Remove the packing (A2) from the packing chamber.
9. Remove the seat. Push the top of the removable seat (A10) toward the center of the valve, and remove the seat through the packing chamber.
10. Install the new replaceable seat:
 - a. Note the gate side and body side of the seat as shown in Figure 4.
 - b. Insert the new seat (A10) through the packing chamber.
 - c. Place the seat behind the lug at the 5 and 7 o'clock positions in the body. Then push the top of the seat into position.

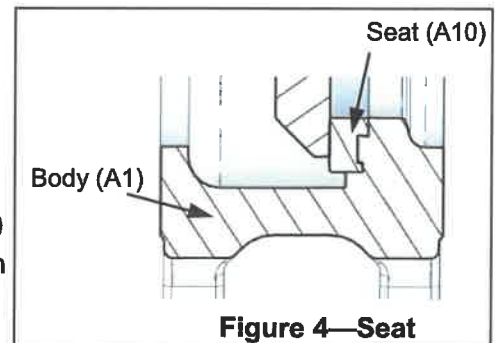

Seat Replacement *Continued*

Reassembling the Valve

1. Reassemble the gate (A3) in the body, with the beveled edge facing away from the resilient seat. See Figure 4.
2. Place the gate in the fully closed position.
3. Reassemble the packing, as described in "Installing New Packing".
4. Reassemble the packing gland (A4), washers (A6), nuts (A7) and bolts (A5). Tighten the nuts evenly to finger tight, plus 1/2 turn.
5. Reassemble the yoke and actuator on the valve.
6. Reconnect the stem to the gate with the two screws and locknuts.
7. Reassemble the pipeline flange and flange bolts, or reassemble the valve in the pipeline if the valve was removed. Refer to the requirements in the "Installation" section.
8. If the actuator is a powered actuator, reconnect power to the actuator.
9. Pressurize the pipeline and inspect the valve for leaks.
10. If the packing leaks, tighten the adjustment nuts (A7) on top of the packing gland. Tighten the nuts evenly and slowly, just enough to stop the leakage. Over tightening will cause excessive operating forces, and will decrease the life of the packing.

Replacing the Gate

See Figure 2 for component identification.



WARNING!

Pipeline pressure can cause personal injury or equipment damage. Relieve pipeline pressure before removing gate stem and packing gland nuts.

1. Relieve the pressure in the pipeline and close the valve.



WARNING!

Accidental operation of power actuator can cause personal injury or equipment damage. Disconnect and lock out power to actuator before servicing.

2. If the actuator is powered, disconnect and lock out power to prevent accidental operation of the actuator.
3. Remove the pipeline flange bolts, and remove the valve from the pipeline.
4. Remove the actuator, actuator yoke, packing gland (A4), and packing (A2) from the valve.
5. Remove and inspect the gate (A3). If the gate appears to be scratched or galled due to too-long flange bolts in the chest area of the body, check for body damage in the tapped flange holes and within the chest cavity. Carefully check the seat for damage. Repair or replace the body, as appropriate.

Gate Replacement *Continued*

6. Remove and inspect the seat components.
7. Replace or reinstall the seat components as described in step 10 in the "Seat Replacement " section.
8. Place the new gate (A3) in the body, in the fully closed position.
9. Replace or reinstall the packing (A2) as described in "Installing New Packing".
10. Replace the yoke and actuator on the valve.
11. Adjust the actuator, yoke, and packing gland so that the valve actuates smoothly full stroke in both directions, and so that there is no evidence of binding or scratching on the gate when the gate is visible in the fully open position.
12. Reinstall the valve in the pipe line —see "Installation" section.
13. If the actuator is a powered actuator, reconnect power to the actuator.
14. Pressurize the pipeline and inspect the valve for leaks.
15. If the packing leaks, tighten the adjustment nuts (A7) on top of the packing gland.

Note: Tighten the nuts evenly and slowly, just enough to stop the leakage. Over tightening will cause excessive operating forces, and will decrease the life of the packing.

Purge Port Option

When purge port options are ordered as illustrated, the intent is that the installer will connect purge lines.



WARNING!

If pipeline is under pressure with purge port plugs in place, release line pressure before removing plugs. Serious or fatal injury may occur if not complied with.

Installation:

1. Remove all purge plugs after valve has been installed in line and before line is pressurized.
2. Connect proper purge line to the ports.
3. Pressurize purge lines and check for leaks.
4. Pressurize pipe line.

See Figure 5 for Purge Port sizes and locations.

DeZURIK
2-24" KGC ES or HD KNIFE GATE VALVES

Purge Port Options

VALVE SIZE		A
INCH	MM	
2	50	1/4 "
3	80	
4	100	
5	125	3/8 "
6	150	
8	200	
10	250	1/2 "
12	300	
14	350	3/4 "
16	400	
18	450	
20	500	3/4 "
22	550	
24	600	

NOTE:

1. VALVE TO HAVE PURGE CONNECTIONS IN THIS AREA WHEN ORDERED BY CATALOG CHARACTERISTIC PCA OR PSC
2. VALVE TO HAVE PURGE CONNECTIONS IN THIS AREA WHEN ORDERED BY CATALOG CHARACTERISTIC PSA OR PSC

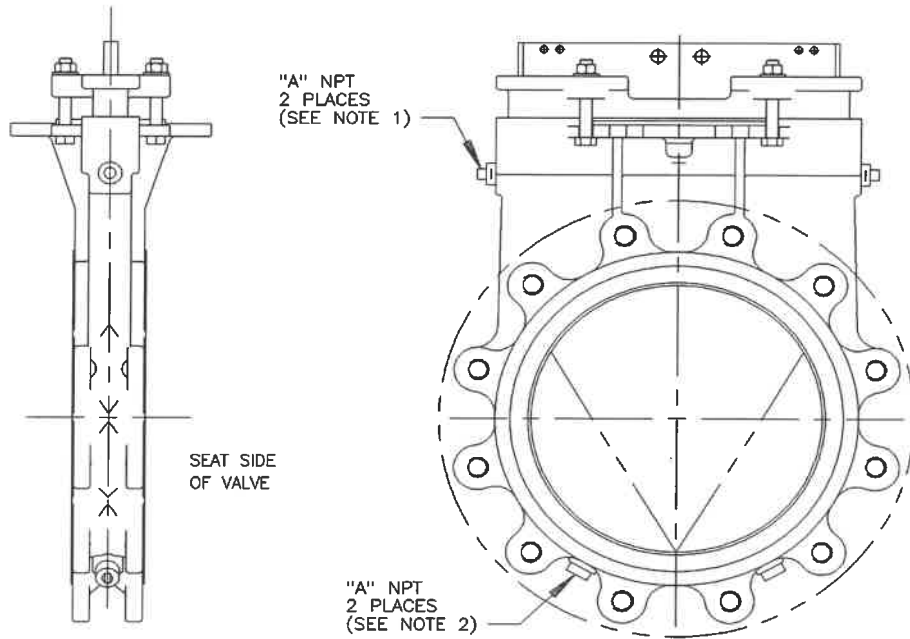

Figure 5—Purge Port Sizes and Locations

Troubleshooting

Condition	Possible Causes	Corrective Action
Packing leaks, with no evidence of galling on gate	Packing is loose	Adjust packing gland
	Packing is worn or torn	Replace packing
Packing leaks and gate is galled	Packing is worn or torn	Replace packing and gate, check seat for damage
Valve leaks when fully closed, with no evidence of galling on gate	Seat is worn or torn	Replace seat
Valve leaks when fully closed and gate is galled	Seat is worn or torn	Replace gate and seat

Guarantee

Products, auxiliaries and parts thereof of DeZURIK, Inc. manufacture are warranted to the original purchaser for a period of twenty-four (24) months from date of shipment from factory, against defective workmanship and material, but only if properly installed, operated and serviced in accordance with DeZURIK, Inc. recommendations. Repair or replacement, at our option, for items of DeZURIK, Inc. manufacture will be made free of charge, (FOB) our facility with removal, transportation and installation at your cost, if proved to be defective within such time, and this is your sole remedy with respect to such products. Equipment or parts manufactured by others but furnished by DeZURIK, Inc. will be repaired or replaced, but only to the extent provided in and honored by the original manufacturers warranty to DeZURIK, Inc., in each case subject to the limitations contained therein. No claim for transportation, labor or special or consequential damages or any other loss, cost or damage shall be allowed. You shall be solely responsible for determining suitability for use and in no event shall DeZURIK, Inc. be liable in this respect. DeZURIK, Inc. does not guarantee resistance to corrosion, erosion, abrasion or other sources of failure, nor does DeZURIK, Inc. guarantee a minimum length of service. Your failure to give written notice to us of any alleged defect under this warranty within twenty (20) days of its discovery, or attempts by someone other than DeZURIK, Inc. or its authorized representatives to remedy the alleged defects therein, or failure to return product or parts for repair or replacement as herein provided, or failure to install and operate said products and parts according to instructions furnished by DeZURIK, Inc., or misuse, modification, abuse or alteration of such product, accident, fire, flood or other Act of God, or failure to pay entire contract price when due shall be a waiver by you of all rights under this warranty.

The foregoing guarantee shall be null and void if, after shipment from our factory, the item is modified in any way or a component of another manufacturer, such as but not limited to, an actuator is attached to the item by anyone other than DeZURIK, Inc. Factory Service personnel. All orders accepted shall be deemed accepted subject to this limited warranty, which shall be exclusive of any other or previous Warranty, and this shall be the only effective guarantee or warranty binding on DeZURIK, Inc., despite anything to the contrary contained in the purchase order or represented by any agent or employee of DeZURIK, Inc., in writing or otherwise, notwithstanding, including but not limited to implied warranties.

THE FOREGOING REPAIR AND REPLACEMENT OBLIGATIONS ARE IN LIEU OF ALL OTHER WARRANTIES, OBLIGATIONS AND LIABILITIES, INCLUDING ALL WARRANTIES OF FITNESS FOR A PARTICULAR PURPOSE OR OF MERCHANTABILITY OR OTHERWISE, EXPRESSED OR IMPLIED IN FACT OR BY LAW, AND STATE DEZURIK, INC.'S ENTIRE AND EXCLUSIVE LIABILITY AND YOUR EXCLUSIVE REMEDY FOR ANY CLAIM IN CONNECTION WITH THE SALE AND FURNISHING OF SERVICES, GOODS OR PARTS, THEIR DESIGN, SUITABILITY FOR USE, INSTALLATION OR OPERATIONS.

Limitation of liability

LIMITATION OF LIABILITY: IN NO EVENT SHALL DEZURIK, INC. BE LIABLE FOR ANY DIRECT, INDIRECT, SPECIAL OR CONSEQUENTIAL DAMAGES WHATSOEVER, AND DEZURIK, INC.'S LIABILITY, UNDER NO CIRCUMSTANCES, WILL EXCEED THE CONTRACT PRICE FOR THE GOODS AND/OR SERVICES FOR WHICH LIABILITY IS CLAIMED. ANY ACTION BY YOU FOR BREACH OF CONTRACT MUST BE COMMENCED WITHIN 12 MONTHS AFTER THE DATE OF SALE.

Sales and Service

For information about our worldwide locations, approvals, certifications and local representative:

Web site: www.dezurik.com E-Mail: info@dezurik.com



250 Riverside Ave. N. Sartell, Minnesota 56377 • Phone: 320-259-2000 • Fax: 320-259-2227

DeZURIK, Inc. reserves the right to incorporate our latest design and material changes without notice or obligation. Design features, materials of construction and dimensional data, as described in this manual, are provided for your information only and should not be relied upon unless confirmed in writing by DeZURIK, Inc. Certified drawings are available upon request.



MANUAL ACTUATOR FOR KNIFE GATE VALVES



Instruction **D10079**
November 2013

DeZURIK

Manual Actuator for Knife Gate Valves

Instructions

These instructions are intended for personnel who are responsible for the installation, operation and maintenance of your manual actuator.

Safety Messages

All safety messages in the instructions are flagged with the word Caution, Warning or Danger. These messages must be followed exactly to avoid equipment damage, personal injury or death.

Safety label(s) on the product indicate hazards that can cause equipment damage, personal injury or death. If a safety label becomes difficult to see, or if a label has been removed, please DeZURIK for replacement.



WARNING!

Personnel involved in the installation or maintenance of valves should be constantly alert to potential emission of process material and take appropriate safety precautions. Always wear suitable protection when dealing with hazardous process materials. Handle valves which have been removed from service with the assumption of process material within the valve.

Inspection

Your manual actuator has been packaged to provide protection during shipment. Carefully inspect the unit for damage upon arrival and file a claim with the carrier if damage is apparent.

Parts

Recommended spare parts are listed on the assembly drawing. These parts should be stocked to minimize downtime.

Order parts from your DeZURIK sales representative, or directly from DeZURIK. When ordering parts, please include the 7-digit part number and 4-digit revision number (example: **9999999R000**) located on the data plate attached to the valve assembly. Also include the part name, the assembly drawing number, the balloon number and the quantity stated on the assembly drawing.

DeZURIK Service

DeZURIK service personnel are available to install, maintain and repair all DeZURIK products. DeZURIK also offers customized training programs and consultation services. For more information, contact your local DeZURIK sales representative or visit our website at www.dezurik.com.

Lubrication

Lubricate the fitting near the top of the yoke monthly with a lithium-based grease.

DeZURIK

Manual Actuator for Knife Gate Valves

Operation

Lever Actuator

1. Loosen the lock screw near the top of the yoke.
2. Move the lever to open or close the valve.
3. Tighten the lock screw to hold the valve in the desired position.

Handwheel, Chainwheel and Bevel-Gear Actuators

Rotate the handwheel or chainwheel clockwise to close the valve.

Note: There is an arrow cast on the wheel to indicate direction of rotation.

Removing Actuator

1. Close the valve.
2. Disconnect the stem from the gate by removing the two screws and nuts.
3. Remove the screws securing the actuator yoke to the valve, then separate the actuator from the valve.

Actuator Installation

1. Close the valve.
2. Set the actuator on the valve and secure it in place with the screws.
3. Connect the stem to the gate with two screws and nuts.

Mounting Handwheel

2–12" C-Series, KBD, KGC, KGL, KGU, KGS, KSV and KUL Valves

Two Spirol® pins are used to connect the handwheel to the yoke sleeve. The use of any other type of pin will result in actuator failure.

1. Rotate the yoke sleeve until the flange on the yoke sleeve touches the yoke.
2. Place the thrust washer and the wave washer over the yoke sleeve.
3. Set the handwheel in place. Turn the wheel so the holes in the wheel line up with the pin ways in the yoke sleeve.
4. Insert a 5/16"-diameter bolt in one of the holes.

Note: This will prevent misalignment. If the holes are not aligned the pin ways in the yoke sleeve could be damaged by the Spirol® pins.



WARNING!

This actuator has been designed to use only heavy-duty Spirol® brand pins. The use of any other type of pin will result in actuator failure. See Figure 1.

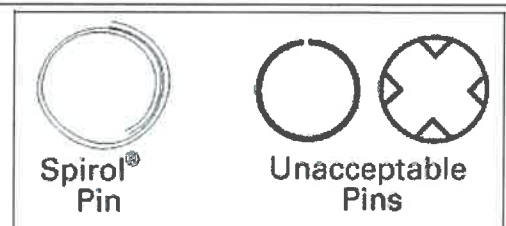

FIGURE 1– Pin Designs

5. Drive a Spirol® pin into the remaining hole in the wheel until the end of the pin is flush with the outer surface of the wheel.
6. Remove the 5/16" bolt installed in Step 4, and drive a Spirol® pin into the hole.
7. Lubricate the actuator as described in the LUBRICATION section of these instructions.

DeZURIK

Manual Actuator for Knife Gate Valves

Mounting Chainwheel

2–12" C-Series, KBD, KGC, KGL, KGU, KGS, KSV and KUL Valves

Two Spirol® pins are used to connect the chainwheel to the yoke sleeve. The use of any other type of pin will result in actuator failure.

1. Rotate the yoke sleeve until the flange on the yoke sleeve touches the yoke.
2. Place the thrust washer and the wave washer over the yoke sleeve.
3. Set the chainwheel in place. Turn the wheel so the holes in the wheel line up with the pin ways in the yoke sleeve.
4. Insert a 5/16"-diameter bolt in one of the holes.

Note: This will prevent misalignment. If the holes are not aligned the pin ways in the yoke sleeve could be damaged by the Spirol® pins.



WARNING!

This actuator has been designed to use only heavy-duty Spirol® brand pins. The use of any other type of pin will result in actuator failure. See Figure 2.

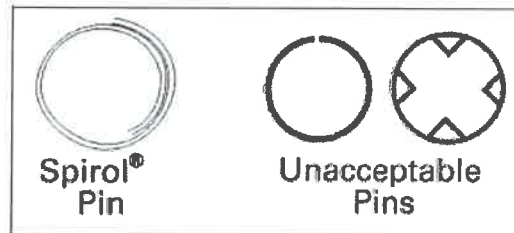

FIGURE 2—Pin Designs

5. Drive a Spirol® pin into the remaining hole in the wheel until the end of the pin is flush with the outer surface of the wheel.
6. Remove the 5/16" bolt installed in Step 4, and drive a Spirol® pin into the hole.

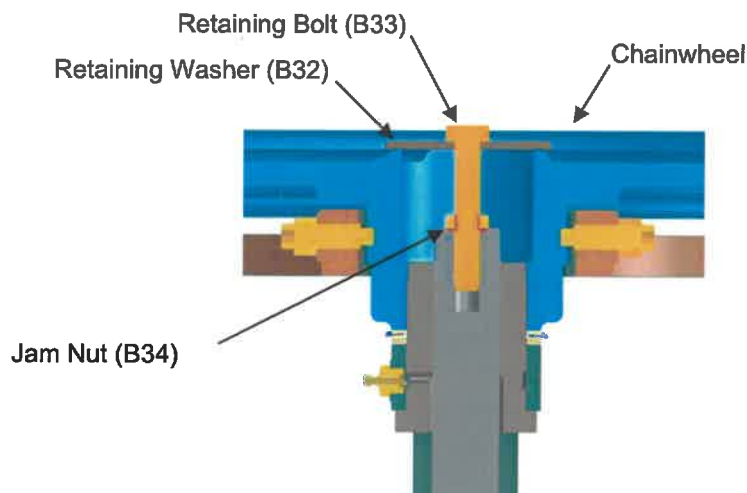

FIGURE 3—Detailed View of Chainwheel Retaining Components on 2-12" Valves

*Spirol® is a registered trademark of CEM Corporation

DeZURIK

Manual Actuator for Knife Gate Valves

Mounting Chainwheel continued

7. As shown in Figure 3, insert the large hex-head retaining bolt (B33) through the 2.5-inch retaining washer (B32) and stake the washer to the head of the bolt. This keeps the washer from sliding down the shaft of the bolt when the valve is open (when the stem is extended upward).
8. Turn the 3/8-16 jam nut (B34) onto the retaining bolt/washer assembly. Turn the nut on far enough to allow the bolt to be fully inserted into the valve stem (detailed in the next step).
9. Turn the retaining bolt assembly into the tapped hole on the valve stem until it bottoms out.
10. Tighten the jam nut firmly against the valve stem. This prevents the retaining bolt assembly (and the chainwheel) from being dislodged if the two Spirol® pins are damaged or fatigued.
11. Lubricate the actuator as described in the LUBRICATION section of these instructions.

Mounting Handwheel or Chainwheel on Large Valves

14-24" KGC, KGL, KGU, KGS and KUL Valves only

1. Rotate the yoke sleeve until the flange on the yoke sleeve touches the yoke.
2. Place the thrust washer over the yoke sleeve.
3. Install the woodruff key in the yoke sleeve keyseat.
4. Align the keyway in the wheel with the key in the yoke sleeve, then slide the wheel into the yoke sleeve until the wheel contacts the shoulder on the yoke sleeve.
5. On valves with a chainwheel actuator, slide the chain guide over the yoke sleeve so the guide loops are directly under the chainwheel.
6. Screw the nut onto the yoke sleeve to retain the wheel.
7. Pin the nut to the yoke sleeve.

EQUIPMENT DATA FORM (MAINTENANCE SUMMARY FORM)

PROJECT: West Hickman WWTP DeZurik Valve Replacement
PURCHASE ORDER:
EQUIPMENT ITEM:
EQUIPMENT / TAG NUMBERS: /
MANUFACTURER: DeZURIK
DESCRIPTION: PEF,20,F1,CI,NBR,CR*GS-12A-HD24
MANUFACTURER'S LOCAL REPRESENTATIVE:
USA

MAINTENANCE REQUIREMENTS

- DeZURIK recommends exercising your valve every 30 days.
- Valve lubrication required upon disassembly only.
- For valve maintenance and lubrication refer to instruction manual(s): D010453
- For actuator maintenance and lubrication refer to instruction manual(s): D010456

RECOMMENDED SPARE PARTS

See Drawing(s) A055446, A055403, A055615, A055418

PART NO.	DESCRIPTION:	QTY	LINE
1361677	20" PLUG FACED CR(REDF)PEF DI	1	A03
1361302	20" GRIT EXCLUDER PEF	2	A04
1361333	20" O-RING NBR -389 PEF	1	A05
1361662	PKG SET 4.5X5.5X1.56 BUNA N	1	A09
1201833	PIN SPIROL 1/4X2-1/4 HD302	1	B02
1014044	SEAL ROD TRANSCOM 08111VB 1.125ODX.875IDX.125THK	1	B1J
1219149	O-RING -159 103 C/S NBR	2	B1N

For current spare parts pricing, contact local manufacturer's representative listed above.

EQUIPMENT DATA FORM (MAINTENANCE SUMMARY FORM)

PROJECT: West Hickman WWTP DeZurik Valve Replacement
PURCHASE ORDER:
EQUIPMENT ITEM:
EQUIPMENT / TAG NUMBERS: /
MANUFACTURER: DeZURIK
DESCRIPTION: KGC,20,ES,F1,S1,SMP,S1-M*MN-HD20-CS
MANUFACTURER'S LOCAL REPRESENTATIVE:
USA

MAINTENANCE REQUIREMENTS

- DeZURIK recommends exercising your valve every 30 days.
- Valve lubrication required upon disassembly only.
- For valve maintenance and lubrication refer to instruction manual(s): D010411
- For actuator maintenance and lubrication refer to instruction manual(s): D010079

RECOMMENDED SPARE PARTS

See Drawing(s) A059095, A046357, A047224

PART NO.	DESCRIPTION:	QTY	LINE
1251550	PACKING SQ 5/8 IN TFE	135	A02
1304396	20" RING ANTI-EXTRUSION	1	A09
1002928	WASHER THRUST	1	B21

For current spare parts pricing, contact local manufacturer's representative listed above.



MATERIALS OF CONSTRUCTION

DRAWING(S): A55403

DESCRIPTION: PEF,20,F1,CI,NBR,CR*GS-12A-HD24

Item	Material
A01	IRON, ASTM A126, CLASS B, HARDNESS TEST
A02	STAINLESS STEEL, TYPE 316L, SINTERED
A03	CHLOROPRENE (CR)
A03	DUCTILE IRON, ASTM A536, GRADE 65-45-12
A04	VIRGIN PTFE
A05	ACRYLONITRILE-BUTADIENE (NBR)
A06	IRON, ASTM A126, CLASS B, HARDNESS TEST
A07	STAINLESS STEEL, TYPE 316L, SINTERED
A08	CARBON STEEL, ZINC PLATED
A09	ACRYLONITRILE-BUTADIENE (NBR)
A10	STEEL, COLD DRAWN, AISI 1018
A11	IRON, ASTM A126, CLASS B
A12	CARBON STEEL, ZINC PLATED
A13	CARBON STEEL, ZINC PLATED
A14	STAINLESS STEEL, SERIES 300
A19	STAINLESS STEEL, TYPE 316
A20	STAINLESS STEEL, TYPE 18-8



MATERIALS OF CONSTRUCTION

DRAWING(S): A46357

DESCRIPTION: KGC,20,ES,F1,S1,SMP,S1-M*MN-HD20-CS

Item	Material
A01	STAINLESS STEEL, TYPE CF-8, ASTM A351, CERTIFIED
A02	PACKING, SQUARE BRAID, TFE YARN, DEZURIK TYPE T
A03	STAINLESS STEEL, TYPE 304, ASTM A240, CERTIFIED
A04	STAINLESS STEEL, ASTM A351, TYPE CF-8M, CERTIFIED
A05	STAINLESS STEEL, TYPE 304
A06	STAINLESS STEEL, TYPE 18-8
A07	STAINLESS STEEL, TYPE 18-8
A09	TEFLON, GLASS FILLED



RECOMMENDED LONG AND SHORT TERM STORAGE PROCEDURES

LONG-TERM STORAGE

1. All resilient seated valves shall be stored in the open (unseated) position.
2. All valves with adjustable packing glands should have the packing gland loosened prior to storage.
3. Valves shall be separately packaged in a sealed polyethylene plastic enclosure with a minimum of one package of desiccant inside, dependent upon valve size.
4. Prepared valves shall be warehoused in a clean, dry, indoor facility on concrete or raised racks, with temperature ranging from 35F to 95F (2°C to 35°C).
5. Valves shall not be near electric motors or other equipment which may emit Ozone which can cause deterioration of elastomers used for valve and actuator components.
6. The valves shall be inspected periodically to replace the desiccant if required, and to repair any damage to the polyethylene plastic enclosures.
7. Valves with cylinder operators and control valves which are stored for extended periods may be subject to cylinder blow-by caused by permanent distortion of any of the seals. Valves should be operated prior to installation and damaged seals replaced.
8. Valves with electric motor operators shall be stored in accordance with the individual motor manufacturer's recommended long-term storage procedures in addition to Paragraphs 1, 2 and 3 above.
9. All electrical components, if applicable, should be inspected and all electrical contacts cleaned before operation.
10. Valves shall be enclosed in fully sheathed wooden crates or boxes.

SHORT-TERM STORAGE

1. Valve should be protected from the weather, avoid exposure to excessive moisture or dirt. Store at temperatures ranging from 35F to 95F (2°C to 35°C).

MANUFACTURER'S CONDITIONS

These conditions apply to all quotations, orders and contracts for DeZURIK, Inc. ("we," "us" or "our")

1. CONSTRUCTION AND LEGAL EFFECT: Our sale to you, as the purchaser of goods from us, is limited to and expressly made conditional on your assent to these typed and printed terms and conditions of sale, the face and reverse side hereof ("These Terms"), all of which form a part of the agreement to sell and which supersede and reject all prior writings (including your order), representations, negotiations with respect hereto and any conflicting terms and conditions of yours, any statement therein to the contrary notwithstanding. The sending of the purchase order for the goods referred to herein, whether or not signed by you, or your acceptance of the goods or payment operates as acceptance by you of These Terms. In case of conflict between These Terms and the terms of your purchase order or acceptance, These Terms govern; any different or conflicting terms submitted by you in any purchase order or acceptance shall be deemed objected to by us and shall be of no effect unless specifically agreed to by us in writing. We will furnish only the quantities and goods specifically listed on the face hereof or the pages attached hereto. We assume no responsibility for other terms or conditions or for furnishing other equipment or material shown in any plans and/or specifications for a project to which the goods quoted or ordered herein pertain or refer. Our published or quoted terms and conditions are subject to change without notice prior to acceptance of order.

2. PRICES: Unless otherwise noted on the face hereof, quotations are valid for 30 days, prices are net, FCA carrier, our factory. Stenographic, clerical, and mathematical errors are subject to correction. Until acceptance of order on These Terms, quoted prices and delivery are subject to change. Thereafter, unless otherwise noted, prices are firm for shipment of goods within 12 months from the relevant quotation date. Our prices are based on current prices for material. We will endeavor to obtain the lowest pricing on materials from our suppliers, but if a significant material price increase occurs between order acceptance and shipment date, goods scheduled to ship beyond 12 months of the quotation date are subject to a price adjustment by the amount necessary to cover such increase.

3. DELIVERY: Dates for the furnishing of services and/or delivery or shipment of goods are approximate only and are subject to change. Quoted lead times are figured from the later of date of acceptance of order on These Terms or from the date of receipt of complete technical data and approved drawings as such may be necessary. We shall not be liable, directly or indirectly, for any delay in or failure to perform caused by carriers or suppliers or delays from labor difficulties, shortages, strikes or stoppages of any sort, failure or delay in obtaining materials, customer requested order changes, fires, floods, storms, accidents, causes designated acts of God or force majeure by any statute or court of law or other causes beyond our reasonable control.

4. SHORTAGE, DAMAGE, ERRORS IN SHIPMENT: Our responsibility ceases upon delivery to carrier. Risk of loss, injury or destruction of property, shall be borne by you from and after our delivery to carrier, and such loss, injury or destruction shall not release you from the obligation to pay the purchase price. You shall note receipt for goods that are not in accordance with bill of lading or express receipt and you shall make claim against such carrier for any shortage, damage or discrepancy in the shipment per the ICC Code for Freight Claims promptly. You shall inspect and examine all items and goods covered by the order when unpacking crated or boxed goods, and if damage is discovered, leave as is until the carrier's agent makes examination and notation on freight or express bill of concealed damage. We will render reasonable assistance to help trace and recover lost goods and collect just claims as a business courtesy, but without obligation. We do not guarantee safe delivery.

5. TAXES: Our prices do not include sales, use, excise, occupation, processing, transportation or other similar taxes which we may be required to pay or collect with respect to any of the materials covered hereby under existing or future law. Consequently, in addition to the price specified herein, such taxes shall be paid by you, or you shall provide us with a tax exemption certificate acceptable to the appropriate taxing authorities. You shall also assume and pay any import or export duties and taxes, with respect to the materials covered by the order, and shall hold harmless and reimburse us therefrom.

6. CREDIT AND PAYMENT: Unless otherwise noted on the face hereof, payment of goods shall be (30) days net in US dollars. Prorated payments shall become due with partial shipments. We reserve the right at any time to suspend credit or to change credit terms provided herein, when, in our sole opinion, your willingness or ability to pay your obligations to us is in doubt. Failure to pay invoices at maturity date, at our election, makes all subsequent invoices immediately due and payable irrespective of terms, and we may withhold all subsequent deliveries until the full account is settled and we shall not, in such event, be liable for non-performance of contract in whole or in part. You agree to pay, without formal notice, 1.5% per month of the amount not paid when due, provided that, if such rate is in excess of applicable governing law, you agree to pay the maximum permitted rate.

7. CANCELLATIONS AND CHANGES: Orders which have been accepted by us are not subject to your cancellation or changes in specifications, except upon our written consent, and we may require, as a condition of such consent, appropriate adjustments in price, delivery schedule and other relevant terms, and in the case of cancellation, cancellation charges. In the event we accept your cancellation, you shall be liable for a cancellation charge equal to the higher of (i) 25% of the purchase price of the item(s), or (ii) any loss or cost incurred by us, including cost of materials, labor, engineering, reconditioning and our profit margin.

8. DEFERRED SHIPMENT: If shipment is deferred at your request, payment of the contract price shall become due when you are notified that the equipment is ready for shipment. If you fail to make payment and/or furnish shipping instructions we may either extend time for so doing or cancel contract. In case of deferred shipment at your request, storage and other reasonable expenses attributable to such delay shall be payable by you.

9. LIMITED WARRANTY: Products, auxiliaries and parts thereof that we manufacture are warranted to the original purchaser for a period of twenty-four (24) months from date of shipment from factory, against defective workmanship and material, but only if properly stored, installed, operated, and serviced in accordance with our recommendations. Repair or replacement, at our option, for items we manufacture will be made free of charge, (FOB) our facility with removal, transportation and installation at your cost, if proved to be defective within such time, and this is your sole remedy with respect to such products. Equipment or parts manufactured by others but furnished by us will be repaired or replaced, but only to the extent provided in and honored by the original manufacturers' warranty, in each case subject to the limitations contained therein. No claim for transportation, labor or special or consequential damages or any other loss, cost or damage shall be allowed. You shall be solely responsible for determining suitability for use and in no event shall we be liable in this respect. We do not guarantee resistance to corrosion, erosion, abrasion or other sources of failure, nor do we guarantee a minimum length of service. Your failure to give written notice to us of any alleged defect under this warranty within twenty (20) days of its discovery, or attempts by someone other than us or our authorized representatives to remedy the alleged defects therein, or failure to return product or parts for repair or replacement as herein provided, or failure to install and operate said products and parts according to instructions we furnished, or misuse, modification, abuse or alteration of such product, accident, fire, flood or other Act of God, or failure to pay entire contract price when due shall be a waiver by you of all rights under this warranty. The foregoing guarantee shall be null and void if, after shipment from our factory, the item is modified in any way or a component of another manufacturer, such as but not limited to; an actuator is attached to the item by anyone other than our Factory Service personnel. All orders accepted shall be deemed accepted subject to this limited warranty, which shall be exclusive of any other or previous Warranty, and this shall be the only effective guarantee or warranty binding on us, despite anything to the contrary contained in the purchase order or represented by any of our agents or employees, in writing or otherwise, notwithstanding, including but not limited to implied warranties.

THE FOREGOING REPAIR AND REPLACEMENT OBLIGATIONS ARE IN LIEU OF ALL OTHER WARRANTIES, OBLIGATIONS AND LIABILITIES, INCLUDING ALL WARRANTIES OF FITNESS FOR A PARTICULAR PURPOSE OR OF MERCHANTABILITY OR OTHERWISE, EXPRESSED OR IMPLIED IN FACT OR BY LAW, AND STATE OUR ENTIRE AND EXCLUSIVE LIABILITY AND YOUR EXCLUSIVE REMEDY FOR ANY CLAIM IN CONNECTION WITH THE SALE AND FURNISHING OF SERVICES, GOODS OR PARTS, THEIR DESIGN, SUITABILITY FOR USE, INSTALLATION OR OPERATIONS.

10. INTELLECTUAL PROPERTY: We shall indemnify and hold you harmless from any amount that you are required to pay to a third-party pursuant to final, non-appealable court order as a result of such third-party's claim that a product sold hereunder infringes any United States patent or copyright of such third party; provided that our obligation of indemnification is contingent upon (a) your notifying us of any such claim within 20 days of receipt thereof, (b) your providing us with exclusive control of the defense and/or settlement thereof, and (c) your cooperating with us in such defense and/or settlement. In the event of such a successful infringement claim by the third party, at our option, we shall either (i) modify the product sold hereunder so that it performs comparable functions without infringement, (ii) obtain a royalty-free license for you to continue using the infringing product or (iii) refund to you the then-depreciated fair market value of the infringing component. We shall have no obligation under this Section to the extent a claim is based upon (a) the combination, operation or use of the product with equipment, products, hardware, software, systems or data that was not provided by us, if such infringement would have been avoided in the absence of such combination, operation or use, or (b) your use of the product in any manner inconsistent with our written materials regarding the use of such product. This Section states our entire liability and your exclusive remedy with respect to any alleged infringement arising from the use of the products sold hereunder or any part thereof and is subject to the other limitations contained in These Terms.

11. LIMITATION OF LIABILITY: IN NO EVENT SHALL WE BE LIABLE FOR ANY DIRECT, INDIRECT, SPECIAL, PUNITIVE, OR CONSEQUENTIAL DAMAGES WHATSOEVER, AND OUR LIABILITY, UNDER NO CIRCUMSTANCES, WILL EXCEED THE CONTRACT PRICE FOR THE GOODS AND/OR SERVICES FOR WHICH LIABILITY IS CLAIMED, ANY ACTION FOR BREACH OF CONTRACT BY YOU, OTHER THAN RIGHTS RESPECTING OUR LIMITED WARRANTY DESCRIBED IN SECTION 9 ABOVE, MUST BE COMMENCED WITHIN THE EARLIER OF 12 MONTHS AFTER THE DATE OF SALE.

12. EXPORT CONTROL COMPLIANCE: You agree and acknowledge that the products are sold in accordance with U.S. export control and sanctions laws, regulations and orders, as they may be amended from time to time. You agree to ascertain and comply with all applicable export and re-export obligations and restrictions, including without limitation, U.S. export and re-export controls under the Export Administration Regulations ("EAR"), International Traffic in Arms Regulations ("ITAR"), and all regulations and orders administered by the U.S. Department of Treasury, Office of Foreign Assets Control (collectively, "U.S. Export Control Laws"). If you are conducting the export from the United States or the re-export from a country outside the United States, you shall comply with such U.S. Export Control Laws and obtain any license or other authorization required to export or re-export the products and related technology. We shall reasonably cooperate and exercise reasonable efforts, at your expense, to support you in obtaining any necessary licenses or authorizations. You shall not export or re-export the products and/or related technology to any country or entity to which such export or re-export is prohibited, including any country or entity under sanction or embargoes administered by the United States. Any diversion contrary to the law of the United States is prohibited. You will not take, and will not solicit us to take, any action that would violate any anti-boycott or any export or import statutes or regulations of the United States or other governmental authorities, and shall defend and indemnify us for any loss or damage arising out of or related to such actions.

13. GENERAL COMPLIANCE WITH LAWS. In addition to your obligations under Section 12 above, you represent and warrant that, in performing your duties under this Agreement, you will comply with, at your sole expense, all applicable laws and regulations of any governmental authority, including your duties involving any required registrations, requirements as to product contents, packaging and labeling, restraint of trade, consumer laws, data privacy and environmental laws. You have had an opportunity to obtain legal advice regarding, and currently comply with, all applicable legal requirements that prohibit unfair, fraudulent or corrupt business practices, including the U.S. Foreign Corrupt Practices Act (FCPA) as well as U.S. and other legal requirements that are designed to combat terrorism and terrorist activities. In addition, neither you nor any of your equity interest owners, officers or directors are named as a "specially designated national" or "blocked person" as designated by the United States Department of the Treasury's Office of Foreign Assets Control under the U.S. PATRIOT Act.

14. INDEMNIFICATION BY YOU. You will indemnify, defend and hold us and our corporate parents and other affiliates and their respective officers, directors, stockholders, members, insurers, attorneys, employees, agents, successors, predecessors, assigns, heirs and personal representatives harmless against any and all liability, claims, suits, actions, losses, liabilities, damages, costs and legal fees arising out of or related to: (i) any conduct of you or any related party as described in Sections 12 or 13 above; or (ii) your breach of any other provision herein.

15. PROPRIETARY INFORMATION: We retain title to all engineering and production prints, drawings, technical data, and other intellectual property, information and documents that relate to the goods and services sold to you. Unless advised by us in writing to the contrary, all such information and documents disclosed or delivered by us to you are to be deemed proprietary to us and shall be used by you solely for the purpose of inspection, installation, and maintenance and not used by you for any other purpose.

16. ARBITRATION: Any controversy or claim arising out of or relating to this Agreement or the breach thereof shall be settled by arbitration administered by the American Arbitration Association in accordance with its Commercial Arbitration Rules, and judgment on the award rendered by the arbitrator(s) may be entered in any court having jurisdiction thereof. The venue for such proceedings shall be St. Cloud, MN.

17. TEXAS WAIVER OF CONSUMER RIGHTS: If you are entitled to its protection, you hereby agree to waive your rights under the Deceptive Trade Practices-Consumer Protection Act, Section 17.41 et seq., Business & Commerce Code, a law that gives consumers special rights and protections. You warrant that, after consultation with an attorney of your own selection, you voluntarily consent to this waiver.

18. APPLICABLE LAW: The rights and duties of the parties shall be governed by the laws of the State of Minnesota.

19. NO OTHER CONTRACT PROVISIONS; OTHER: This is the entire agreement with respect to the products. Terms and conditions of your order shall be without force and effect, except to the extent identical herewith. No dealer, broker, branch manager, agent, employee or representative of ours has any power of authority except to take orders for our products and to submit the same to us, at our factory, for our approval and acceptance on the terms herein or rejection. There are no representations, agreements, obligations, or conditions, expressed or implied, statutory or otherwise, relating to the subject matter hereof, other than herein contained. DeZURIK, Inc. and related terms (we, us and our) shall refer to DeZURIK, Inc. and its affiliates. If any provision hereof is invalid or not enforceable under applicable law, the remaining provisions shall remain in full force and effect. Any assignment of your rights hereunder without our consent (which shall not be unreasonably withheld) shall be void. These Terms shall be binding on your successors and assigns. Our failure to require your performance of any of These Terms shall not serve as a waiver or diminish our rights to require strict performance of such provision or These Terms.