

LEXINGTON-FAYETTE URBAN COUNTY GOVERNMENT CONTRACT CHANGE ORDER Page 1 of 2	Date	January 5, 2017	
	Project	Senior Citizen Center Constructio	
	Location	Lexington	
To (Contractor): Marrillia Design & Construction 259 West Short Street Suite 325 Lexington, KY 40507	Contract No	227-2014	
	Original Contract Amt	\$8,882,900.00	
	Cumulative Amount of Previous Change Orders	\$1,643,894.37	
	Percent Change - Previous Change Orders		18.51%
	Total Contract Amount Prior to this Change Order	\$10,526,794.37	
	Change Order No	66	

You are hereby requested to comply with the following changes from the contract plans and specification.

Current Change Order

Item No	Description of changes-quantities, unit prices, change in completion date, etc	Decrease in contract price	Increase in contract price	
1	Replace lavatory in companion RR 231 per PR 109 as required by the ADA		\$3,195.00	
	Total decrease	\$0.00		
	Total increase		\$3,195.00	
	Net Amount of this Change Order	\$3,195.00		
	New Contract Amount Including this Change Order	\$10,529,989.37		
	Percent Change - This Change Order			0.04%
	Percent Change - All Change Orders			18.54%

The time provided for the completion in the contract and all provisions of the contract will apply hereto.

Recommended by <i>Gayce Tramm</i> for <i>Janet Lind Boudon</i> (Project Manager)	Date	1/5/17
Accepted by <i>Josh Marcella</i> (Contractor)	Date	1/5/17
Approved by <i>[Signature]</i> (Director)	Date	1-5-17
Approved by <i>[Signature]</i> (Commissioner)	Date	1/10/17
Approved by <i>[Signature]</i> (Mayor or CAO)	Date	1/10/17

JUSTIFICATION FOR CHANGE

PROJECT Senior Citizen Center Construction

CONTRACT NO 227-2014

CHANGE ORDER # 66

1. Necessity for change This change will make the companion restroom 231 ADA compliant.

2. Is proposed change an alternate bid? ___ Yes X No
3. Will proposed change alter the physical size of the project? ___ Yes X No
If "Yes", explain.

4. Effect of this change on other prime contractors: N/A

5. Has consent of surety been obtained? ___ Yes X Not Necessary
6. Will this change affect expiration or extent of insurance coverage? ___ Yes X No
If "Yes", will the policies be extended? ___ Yes ___ No
7. Effect on operation and maintenance costs:

8. Effect on contract completion date: 0 working days

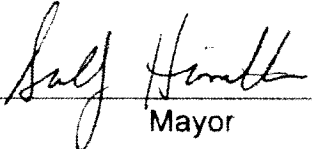

Mayor

1-10-17

Date



Proposal Request Transmittal

2016-08-31 10:00 AM

9400 W. Alameda, Suite 100, Littleton, CO 80120

Project	LFUCG Senior Citizens' Center 201333	Request	8/31/2016
Task	Sink Replacement at 231 Companion Restroom	Request ID	PR-109
	Proposal Request	Request No.	01026
	For Review and Response	Request Status	Info Exchange

Contact

Client	Owner	Phone	Cell
Harding Dowell	EOP Architects	hdowell@eopa.com	(859) 231-7538
Jim Martin	Marrillia Design and Construction	martin@marrillia.com	(859) 685-0414
Travis Harris	Marrillia Design and Construction	tharris@marrillia.com	

Created by: Harding Dowell

Description

Please replace and relocate the wall mounted lavatory sink in Companion Restroom 231, as required by the building inspector. Install sink per manufacturer's recommendations, and reconnect new sink to an existing plumbing. Make the necessary adjustments to plumbing routing within the wall to achieve a neat and finished appearance and full functionality. Replace drywall where selective demolition is required, and repair to match. Avoid damage to, and as possible, re-approach to, chairs, accessibility, and finishes. All repairs to comply with current code requirements and standards.

Proposal Request Transmittal

8/31/2016

01026

and soap dispenser in accordance with the attached sketch.

The sink model referenced in the attached cut sheet is available at Ferguson Enterprises; if ordered today, it can be ready by noon tomorrow. Brock McVey has been contacted as well regarding the sink model, but no response has been received at this time.

Work shall be performed as soon as possible so that final inspections can be made prior to September 6.

Thanks,

Harding

Transmittal Summary

Quantity	Date	Description	File Name
1	8/31/2016	K-1729 .spec.pdf	K-1729 .spec.pdf
1	8/31/2016	160831_PR-109_SKA-142.pdf	160831_PR-109_SKA-142.pdf

Notes

Brian Gravitt	(Marrillia Design and Construction)
Josh Marrillia	(Marrillia Design and Construction)
Joyce Thomas	(LFUCG)
Martin Woodford	(LFUCG)
Greg Brumagen	(CMTA)
Sam Claxton	(CMTA)

KOHLER

Chesapeake™ Wall-Mount Bathroom Sink K-1729

Features

- Ledge-back
- With hanger.
- With overflow.
- Drilled for concealed arm carrier.
- 4 " (102 mm) centers.
- 20 " (508 mm) x 18-1/4 " (464 mm)

Material

- Vitreous china.

Installation

- Wall-mount installation.

Recommended Accessories

K-8998 P-Trap

Components

Additional included component/s Hanger (2 Required).



ADA

Codes/Standards

ASME A112.19.2/CSA B45.1

ADA

ICC/ANSI A117.1

See website for detailed warranty information

Available Color/Finishes

Color tiles intended for reference only.

Color	Code	Description
-------	------	-------------

- | | | |
|---|----|---------|
| ✓ | 0 | White |
| ✓ | 96 | Biscuit |
| ✓ | 47 | Almond |

USA/Canada 1-800-4KOHLER 1-800-456-4537

Kohler Co. reserves the right to make revisions without notice to its products and specifications. For the most current specifications, visit www.kohler.com.

©2011 Kohler Co.

THE BOLD LOOK
OF
KOHLER

KOHLER

Chesapeake™ Wall-Mount Bathroom Sink K-1729

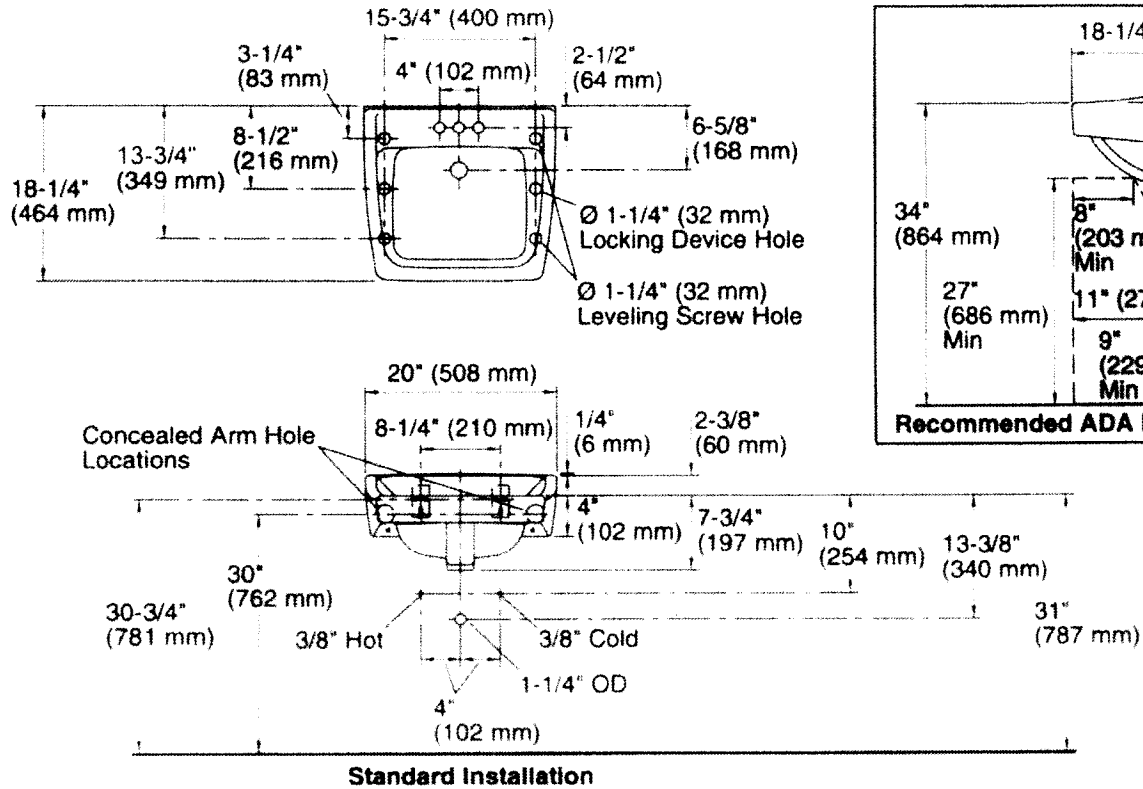

Technical Information

All product dimensions are nominal.

Bowl configuration	Single
Installation	Wall-mount
Bowl area (Only)	Length 14" (356 mm) Width 12" (305 mm) With overflow Yes Water depth 4-7/8" (124 mm)
Bowl area	With overflow Yes
Number of deck holes	3
Faucet hole(s)	1-1/4" (32 mm)
Drain hole	1-3/4" (44 mm)

Notes

Install this product according to the installation instructions.

ADA compliant when installed to the specific requirements of these regulations.

USA/Canada 1-800-4KOHLER 1-800-456-4565

Kohler Inc. reserves the right to make revisions without notice to its specifications for the most current Specification sheet.

©2011 Kohler

THE BOLD LOOK
OF
KOHLER

INSTALL KOHLER
 CHESAPEAKE K-1729-0
 (WHITE, CONFIRM FAUCET
 HOLE LOCATIONS ARE
 APPROPRIATE FOR EXISTING
 FAUCET) AND RECONNECT
 ALL PLUMBING AND
 FIXTURES. PATCH AND
 REPAINT DRYWALL AS
 REQUIRED

PATCH WALL
 WHERE SOAP
 DISPENSER
 REMOVED

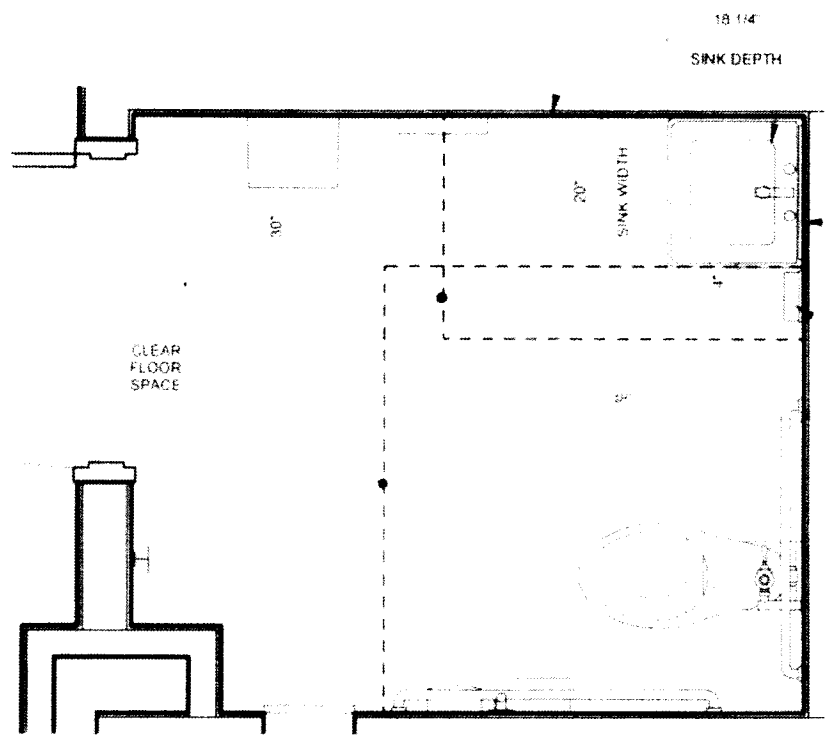

INSTALL 18"X36"
 MIRROR, CENTER
 ON NEW SINK

RELOCATE SOAP
 DISPENSER

1 REVISIONS TO 231 COMPANION TOILET

SKA-142 SCALE 1/2" = 1'-0"



LEXINGTON SENIOR
 CENTER

195 LIFE LANE
 LEXINGTON, KY 40502

PR-109

SKA-142



Alternates
 (FUGG Replacement Senior Citizen Center
 Lexington, KY

11/11/11

Approved Pending Assigned Change Order #

PR-125 Replace the Lavatory in Companion Restroom 231 per Proposal Request No. 109

Replace the Lavatory in Companion Restroom 231 per Proposal Request No. 109

Replace the Lavatory in Companion Restroom 231 - TECO Mechanical

Replace/Patch Drywall at Lavatory "Wet" Wall - Bennett's Carpets

Repaint Walls as Required Upon Completion of the Lavatory Relocation - Simpson & Co

Clean-up of Restroom Upon Completion of the Work - Marrillia General Trades

Quantity	Units	Hr	Rate	Labor	Materials	Sub	Equipment	Other
				(\$)	(\$)	(\$)	(\$)	(\$)
	1	Is		1,974.00				1,974.00
	1	Is		174.00				174.00
	1	Is		160.00				160.00
	2	Hr		48.12				96.24
				0	0	0	0	2,244.24

Cost of In-Place Construction (Labor, Materials and Equipment)

Marrillia Design and Construction Overhead Percentage

Overhead - Marrillia Design and Construction

Marrillia Design and Construction Profit Percentage

Profit - Marrillia Design and Construction

General Liability Insurance - Construction

Bolton's Tax - Bond 10%

Performance and Payment Bond (Rate of \$9.40 per \$1000 of Cost for \$0 - \$2,500,000)

Performance and Payment Bond (Rate of \$8.15 per \$1000 of Cost for \$2,500,000 - \$5,000,000)

Performance and Payment Bond (Rate of \$7.20 per \$1000 of Cost for \$5,000,000 and up)

KY Surcharge on Project Bonds (1% of Bond Cost)

Local Municipality Tax on Project Bonds (5% of Bond Cost)

Total Construction Cost

2,244.24

TECO

MECHANICAL CONTRACTOR, INC.

837 FLOYD DRIVE
LEXINGTON, KY 40505
PHONE (859) 255-6893

P.O. BOX 5043
LEXINGTON, KY 40505
FAX (859) 233-3430

August 31, 2016

Marrillia Design & Construction
259 West Short Street, Suite 325
Lexington, Kentucky 40507
Attn: Josh Marrillia

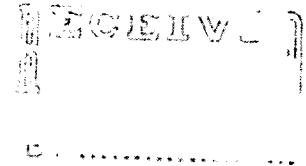

Re: Lexington Senior Center - PR-109 Cost to Replace Lavatory in Companion RR 231.

Josh,

The following represents the cost to replace the companion lavatory in Restroom 231

LABOR: 20 HOURS	\$ 1,700.00
Kohler K-1729 Lavatory & Misc Fittings	\$ 117.00
6% Sales tax	\$ 7.00
TOTAL	\$ 1,824.00

If you have any questions, please call.

Sincerely

Scott Hedger
Project Manager

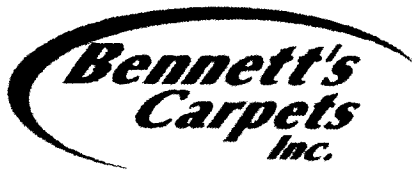

Bennett's Carpets, Inc.
 149 Steve Drive
 Russell Springs, KY 42642
 (270) 866-6930
 Fax (270) 866-6200

QUOTATION • PROPOSAL

TO:	Marrilla Construction	DATE:	09/07/13
ATT:	Travis		
RE:	Lexington Senior Citizens PR 109		

Description of Work: We hereby submit this estimate for furnishing and installing the following in accordance with plans and specifications including insurance:

TO replace drywall at hand dryer

Material \$75.00
 Labor \$600.00

 TOTAL \$675.00

Total Quotation \$

Note: This quotation will become void if not accepted within 30 days.
 We include no demolition unless stipulated

Reggie Roy

Acceptance: _____ Date: _____

Company Title: _____

This Quotation/Proposal is provided only as a guide. It is not intended to be a contract. The actual contract shall be the contract documents prepared by the contractor. The contractor shall be responsible for providing the contract documents to the client. The client shall be responsible for reviewing the contract documents and accepting or rejecting the proposal.