

AREA NOTIFICATION MAP
1"=200'

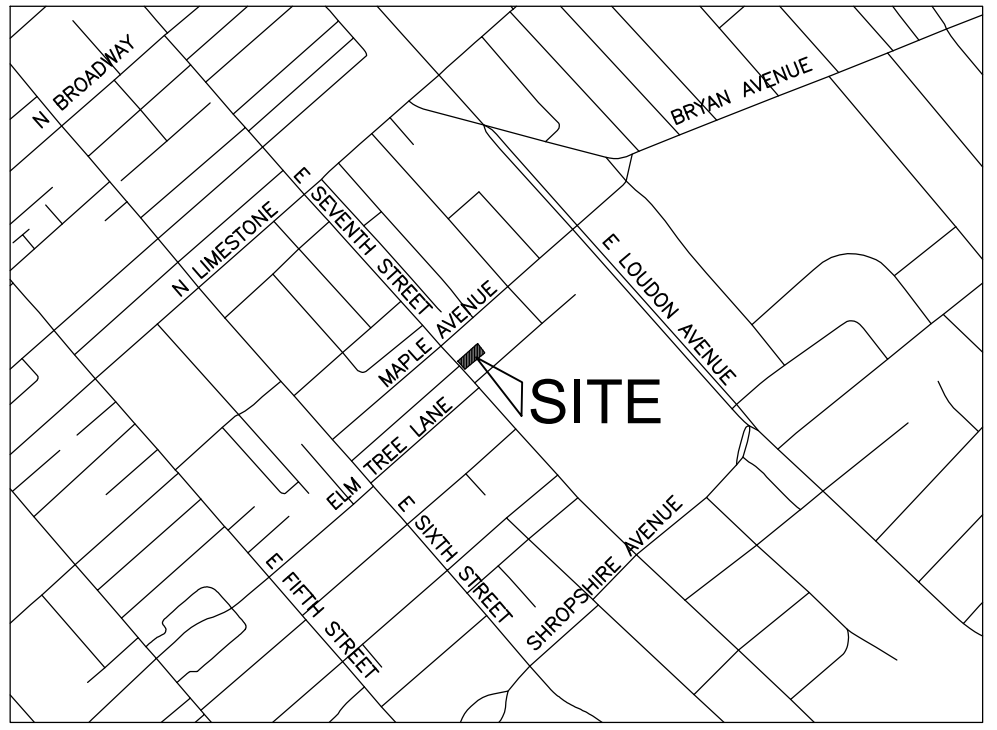

VICINITY MAP

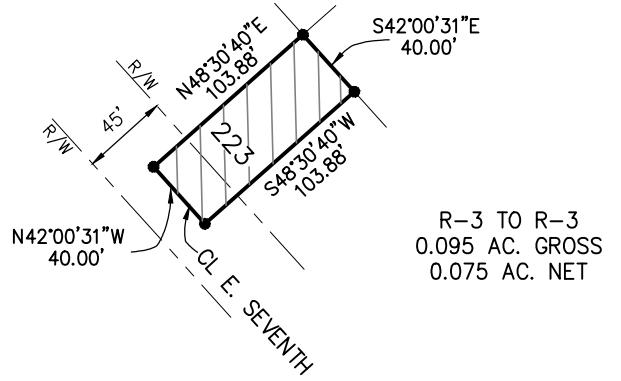

PROPERTY MAP
1"=100'

ZOMAR					
TITLE: PLN-MAR-24-00016		FROM	TO	GROSS	NET
PROPERTY ADDRESS: 223 E SEVENTH STREET		B-1	R-3	0.095 AC.	0.075 AC.
OWNER:	L.O.P.1, LTD. 1904 DEAUVILLE DRIVE LEXINGTON, KY 40504	<div style="border: 1px solid black; padding: 5px; text-align: center;"> <p>STATE OF KENTUCKY</p> <p>WESLEY B. WITT 2187</p> <p>LICENSED PROFESSIONAL LAND SURVEYOR</p> </div>			
APPLICANT:	L.O.P.1, LTD. 1904 DEAUVILLE DRIVE LEXINGTON, KY 40504				
PREPARED BY:	WESLEY B WITT, INC.				
DATE PREPARED:	SEPTEMBER 3, 2024				