

RESOLUTION NO. 259 -2013

A RESOLUTION ACCEPTING THE BID OF WORLDWIDE EQUIPMENT, ESTABLISHING A PRICE CONTRACT FOR CNG CAB & CHASSIS FOR REFUSE VEHICLES, FOR THE DIVISION OF FACILITIES AND FLEET MANAGEMENT.

---

BE IT RESOLVED BY THE COUNCIL OF THE LEXINGTON-FAYETTE URBAN COUNTY GOVERNMENT:

Section 1 - That the bid of Worldwide Equipment, establishing a price contract for CNG Cab & Chassis for Refuse Vehicles, for the Division of Facilities and Fleet Management, be and hereby is accepted and approved as to the specifications and amounts set forth in the terms of the bid, which is attached hereto and incorporated herein by reference.

Section 2 - That this Resolution shall become effective on the date of its passage.

PASSED URBAN COUNTY COUNCIL: June 6, 2013

\_\_\_\_\_  
MAYOR

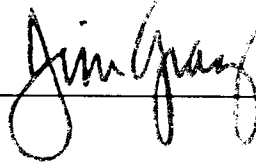

ATTEST:

Susan Lembs  
CLERK OF URBAN COUNTY COUNCIL

RESOLUTION NO. 259 -2013

A RESOLUTION ACCEPTING THE BID OF WORLDWIDE EQUIPMENT, ESTABLISHING A PRICE CONTRACT FOR CNG CAB & CHASSIS FOR REFUSE VEHICLES, FOR THE DIVISION OF FACILITIES AND FLEET MANAGEMENT.

---

BE IT RESOLVED BY THE COUNCIL OF THE LEXINGTON-FAYETTE URBAN COUNTY GOVERNMENT:

Section 1 - That the bid of Worldwide Equipment, establishing a price contract for CNG Cab & Chassis for Refuse Vehicles, for the Division of Facilities and Fleet Management, be and hereby is accepted and approved as to the specifications and amounts set forth in the terms of the bid, which is attached hereto and incorporated herein by reference.

Section 2 - That this Resolution shall become effective on the date of its passage.

PASSED URBAN COUNTY COUNCIL: June 6, 2013

/s/ Jim Gray  
MAYOR

ATTEST:

/s/ Susan Lamb  
CLERK OF URBAN COUNTY COUNCIL

RESOLUTION NO. 259 -2013

A RESOLUTION ACCEPTING THE BID OF WORLDWIDE EQUIPMENT, ESTABLISHING A PRICE CONTRACT FOR CNG CAB & CHASSIS FOR REFUSE VEHICLES, FOR THE DIVISION OF FACILITIES AND FLEET MANAGEMENT.

---

BE IT RESOLVED BY THE COUNCIL OF THE LEXINGTON-FAYETTE URBAN COUNTY GOVERNMENT:

Section 1 - That the bid of Worldwide Equipment, establishing a price contract for CNG Cab & Chassis for Refuse Vehicles, for the Division of Facilities and Fleet Management, be and hereby is accepted and approved as to the specifications and amounts set forth in the terms of the bid, which is attached hereto and incorporated herein by reference.

Section 2 - That this Resolution shall become effective on the date of its passage.

PASSED URBAN COUNTY COUNCIL: June 6, 2013

/s/ Jim Gray  
MAYOR

ATTEST:

/s/ Susan Lamb  
CLERK OF URBAN COUNTY COUNCIL



# Lexington-Fayette Urban County Government

200 E. Main St  
Lexington, KY 40507

## Master

File Number: 0558-13

<b>File ID:</b> 0558-13	<b>Type:</b> Resolution	<b>Status:</b> Approved
<b>Version:</b> 1	<b>Contract #:</b>	<b>In Control:</b> Urban County Council
<b>Division:</b> Central Purchasing	<b>Cost:</b>	<b>File Created:</b> 05/17/2013
<b>File Name:</b> Bid #62-2013 CNG Cab & Chassis For Refuse Vehicles Recommendation		<b>Final Action:</b> 06/06/2013

**Title:** A Resolution accepting the bid of Worldwide Equipment, establishing a price contract for CNG Cab and Chassis for Refuse Vehicles, for the Div. of Facilities and Fleet Management. (2 Bids, Low) [Baradaran]

### Notes:

**Code Sections:** **Agenda Date:** 06/06/2013

**Indexes:** **Agenda Number:** 4.

**Sponsors:** **Enactment Date:** 06/06/2013

**Attachments:** Worldwide Equipment Bid #62-2013.pdf, Mack Warranty Info.pdf, 00392586.DOC **Enactment Number:** R-259-2013

**Deed #:** **Hearing Date:**

**Drafter:** Todd Slatin **Effective Date:**

### Approval History

Version	Date	Approver	Action
1	05/17/2013	Todd Slatin	Approve
1	05/20/2013	Sally Hamilton	Approve
1	05/20/2013	Dave Barberie	Approve

### History of Legislative File

Ver- sion:	Acting Body:	Date:	Action:	Sent To:	Due Date:	Return Date:	Result:
1	Urban County Council	05/23/2013					
1	Urban County Council	05/23/2013	Received First Reading	Urban County Council	06/06/2013		
	<b>Action Text:</b> Received First Reading to the Urban County Council due back on 6/6/2013						
1	Urban County Council	06/06/2013					

is in reverse gear or view may be manually selected. Cameras **shall** be protected by a stainless steel cage. System components **shall** be provided with a two (2) year extended warranty.

## PRICE SHEET for CHASSIS

### Pricing-----

- 1) CNG 2013 Mack LEU 633, or equal, dual drive, tandem axle, cab, and chassis truck, with a GVW of 64,000 pounds minimum or equal.

Quantity to be Purchased

Price each

6

\$ 134,387.<sup>00</sup> (Each)

- 2) Please provide warranty repair location for making repairs

945 Nandino Blvd Lexington Ky 40511

- 3) Describe the bidder's ability to provide maintenance service in a timely manner as well as its availability of the chassis parts. If more space is needed, please attach additional pages.

Worldwide Equipment is the ONLY certified Cummins ISC-6 warranty facility in Fayette County. WUE will provide the LFUGG with fast and prompt service for parts & service and whatever is needed LFUGG will #1 priority when it shows up at the shop.

**INVITATION TO BID**

Bid Invitation Number: #62-2013

Date of Issue: 05/02/2013

Sealed bids will be received in the office of the Division of Central Purchasing, 200 East Main Street, Lexington, Kentucky, until **2:00 PM**, prevailing local time on **05/16/2013**. Bids must be received by the above-mentioned date and time. Mailed bids should be sent to:

**Division of Central Purchasing  
200 East Main Street, Rm 338  
Lexington, KY 40507, (859) 258-3320**

**The Lexington-Fayette Urban County Government assumes no responsibility for bids that are not addressed and delivered as indicated above. Bids that are not delivered to the Division of Central Purchasing by the stated time and date will be rejected.**

All bids must have the company name and address, bid invitation number, and the commodity/service on the outside of the envelope.

Bids are to include all shipping costs to the point of delivery located at: 200 E. Main Street, Lexington, KY 40507

Bid Security Required:  Yes  No      Performance Bond Required:  Yes  No  
*Cashier Check, Certified Check, Bid Bond (Personal checks and company checks will not be acceptable).*

Quantity	Commodity/Service
<b>Price Contract</b>	<b>CNG Cab &amp; Chassis for Refuse Vehicles</b>

<b><u>Check One:</u></b>	<b><u>Proposed Delivery:</u></b>
<input type="checkbox"/> Bid Specifications Met <input checked="" type="checkbox"/> Exceptions to Bid Specifications. <i>Exceptions shall be itemized and attached to bid proposal submitted.</i>	<u>120-150</u> days after acceptance of bid.

<b><u>Procurement Card Usage</u></b>	
<input type="checkbox"/> Yes	The Lexington-Fayette Urban County Government will be using Procurement Cards to purchase goods and services and also to make payments. Will you accept Procurement Cards?
<input checked="" type="checkbox"/> No	

Submitted by: Worldwide Equipment  
 Firm 445 Nandine Blvd  
 Address Lexington Ky 40511  
 City, State & Zip

**Bid must be signed:  
(original signature)**

[Signature]  
 Signature of Authorized Company Representative – Title  
 Representative's Name (Typed or printed) Jim Dotson  
 Area Code - Phone - Extension 859-281-5152 70516 Fax # 859-253-4639  
 E-Mail Address jimdotson@thetruckpeople.com

**The Affidavit in this bid must be completed before your firm can be considered for award of this contract.**

# **I. GREEN PROCUREMENT**

## **A. ENERGY**

The Lexington-Fayette Urban County Government is committed to protecting our environment and being fiscally responsible to our citizens.

The Lexington-Fayette Urban County Government mandates the use of Energy Star compliant products if they are available in the marketplace (go to [www.Energystar.gov](http://www.Energystar.gov)). If these products are available, but not submitted in your pricing, your bid will be rejected as non-compliant.

ENERGY STAR is a government program that offers businesses and consumers energy-efficient solutions, making it easy to save money while protecting the environment for future generations.

### Key Benefits

- These products use 25 to 50% less energy
- Reduced energy costs without compromising quality or performance
- Reduced air pollution because fewer fossil fuels are burned
- Significant return on investment
- Extended product life and decreased maintenance

## **B. GREEN SEAL CERTIFIED PRODUCTS**

The Lexington-Fayette Urban County Government is also committed to using other environmentally friendly products that do not negatively impact our environment. Green Seal is a non-profit organization devoted to environmental standard setting, product certification, and public education.

Go to [www.Greenseal.org](http://www.Greenseal.org) to find available certified products. These products will have a reduced impact on the environment and on human health. The products to be used must be pre-approved by the LFUCG prior to commencement of any work in any LFUCG facility. If a Green Seal product is not available, the LFUCG must provide a signed waiver to use an alternate product. Please provide information on the Green Seal products being used with your bid response.

## **C. GREEN COMMUNITY**

**The Lexington-Fayette Urban County Government (LFUCG) serves as a principal, along with the University of Kentucky and Fayette County Public Schools, in the Bluegrass Partnership for a Green Community. The Purchasing Team component of the Partnership collaborates on economy of scale purchasing that promotes and enhances environmental initiatives. Specifically, when applicable, each principal is interested in obtaining best value products and/or services which promote environment initiatives via solicitations and awards from the other principals.**

**If your company is the successful bidder on this Invitation For Bid, do you agree to extend the same product/service pricing to the other principals of the Bluegrass Partnership for a Green Community (i.e. University of Kentucky and Fayette County Schools) if requested?**

Yes  No

**AFFIDAVIT**

Comes the Affiant, Jim Dotson, and after being first duly sworn under penalty of perjury as follows:

1. His/her name is Jim Dotson and he/she is the individual submitting the bid or is the authorized representative of

Worldwide Equipment

the entity submitting the bid (hereinafter referred to as "Bidder").

2. Bidder will pay all taxes and fees, which are owed to the Lexington-Fayette Urban County Government at the time the bid is submitted, prior to award of the contract and will maintain a "current" status in regard to those taxes and fees during the life of the contract.

3. Bidder will obtain a Lexington-Fayette Urban County Government business license, if applicable, prior to award of the contract.

4. Bidder has authorized the Division of Central Purchasing to verify the above-mentioned information with the Division of Revenue and to disclose to the Urban County Council that taxes and/or fees are delinquent or that a business license has not been obtained.

5. Bidder has not knowingly violated any provision of the campaign finance laws of the Commonwealth of Kentucky within the past five (5) years and the award of a contract to the Bidder will not violate any provision of the campaign finance laws of the Commonwealth.

6. Bidder has not knowingly violated any provision of Chapter 25 of the Lexington-Fayette Urban County Government Code of Ordinances, known as "Ethics Act."

7. Bidder acknowledges that "knowingly" for purposes of this Affidavit means, with respect to conduct or to circumstances described by a statute or ordinance defining an offense, that a person is aware or should have been aware that his conduct is of that nature or that the circumstance exists.

Further, Affiant sayeth naught.

Jim Dotson

STATE OF Kentucky

COUNTY OF Fayette

The foregoing instrument was subscribed, sworn to and acknowledged before me

by Jim Dotson on this the 14 day of May, 2013.

My Commission expires: 4/26/17 ID 488195

Stephen Cantley  
NOTARY PUBLIC, STATE AT LARGE

***Please refer to Section II. Bid Conditions, Item "U" prior to completing this form.***



EQUAL OPPORTUNITY AGREEMENT

The Law

Title VII of the Civil Rights Act of 1964 (amended 1972) states that it is unlawful for an employer to discriminate in employment because of race, color, religion, sex, age (40-70 years) or national origin.

Executive Order No. 11246 on Nondiscrimination under Federal contract prohibits employment discrimination by contractor and sub-contractor doing business with the Federal Government or recipients of Federal funds. This order was later amended by Executive Order No. 11375 to prohibit discrimination on the basis of sex.

Section 503 of the Rehabilitation Act of 1973 states:

*The Contractor will not discriminate against any employee or applicant for employment because of physical or mental handicap.*

Section 2012 of the Vietnam Era Veterans Readjustment Act of 1973 requires Affirmative Action on behalf of disabled veterans and veterans of the Vietnam Era by contractors having Federal contracts.

Section 206(A) of Executive Order 12086, Consolidation of Contract Compliance Functions for Equal Employment Opportunity, states:

*The Secretary of Labor may investigate the employment practices of any Government contractor or sub-contractor to determine whether or not the contractual provisions specified in Section 202 of this order have been violated.*

\*\*\*\*\*

The Lexington-Fayette Urban County Government practices Equal Opportunity in recruiting, hiring and promoting. It is the Government's intent to affirmatively provide employment opportunities for those individuals who have previously not been allowed to enter into the mainstream of society. Because of its importance to the local Government, this policy carries the full endorsement of the Mayor, Commissioners, Directors and all supervisory personnel. In following this commitment to Equal Employment Opportunity and because the Government is the benefactor of the Federal funds, it is both against the Urban County Government policy and illegal for the Government to let contracts to companies which knowingly or unknowingly practice discrimination in their employment practices. Violation of the above mentioned ordinances may cause a contract to be canceled and the contractors may be declared ineligible for future consideration.

Please sign this statement in the appropriate space acknowledging that you have read and understand the provisions contained herein. Return this document as part of your application packet.

Bidders

*I/We agree to comply with the Civil Rights Laws listed above that govern employment rights of minorities, women, Vietnam veterans, handicapped and aged persons.*

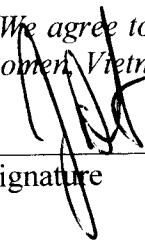
  
Signature

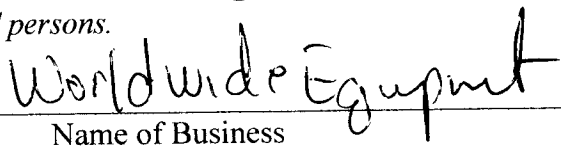
  
Name of Business

against the bidder before or by any court, governmental body or agency or other tribunal or authority which would, if adversely determined, have a materially adverse effect on the authority or ability of bidder to perform its obligations under this bid response or bid contract, or which question the legality, validity or enforceability hereof or thereof.

18. Bidder understands and agrees that its employees, agents, or subcontractors are not employees of LFUCG for any purpose whatsoever. Bidder is an independent contractor at all times related to the bid response or bid contract.
19. If any term or provision of this bid contract shall be found to be illegal or unenforceable, the remainder of the contract shall remain in full force and such term or provision shall be deemed stricken.

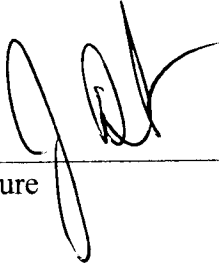
A handwritten signature in black ink, consisting of a large, stylized 'J' followed by a series of loops and a final flourish.

Signature

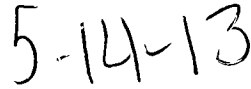
A handwritten date in black ink, written as '5-14-13'.

Date

EXCEPTION PAGE

2.1. 1-6 for Cummins 120v/1000 watt  
Block Heater only Available

2.2. 8. AD-IP is not avail. per  
Mack Sales Eng. Mentor/walco 1800  
is standard w/Mack TerraPro Meet or exceeds, specs  
of Bendix AD-IP. Not Avail on Mack Chassis  
because of the application and purging. (JA 5-15-13)  
Bendix is not recommended for this  
application due to not enough air stored  
in the dryer as required for purge.

# **FOR INFORMATIONAL PURPOSES ONLY---HEIL PYTHON MULTIPACK SPECIFICATIONS**

## **1.0 SCOPE---HEIL PYTHON MULTIPACK**

1.1 This section describes the minimum requirements for an automated side loading high compaction refuse body with a rear loading tailgate. **Heil Python MultiPack**. The intent for establishing this price contract is to purchase six (6) Heil Python MultiPack bodies to be installed on CNG 2014 Mack LEU 633, dual drive, tandem axle, cab, and chassis truck, with a GVW of 64,000 pounds minimum **or equal**. Specifications associated with a CNG 2014 Mack LEU 633, dual drive, tandem axle, cab, and chassis truck, with a GVW of 64,000 pounds minimum **or equal** are enclosed for informational purposes only.

## **2.0 REQUIREMENTS ---Heil Python MultiPack**

### **2.1 Body Construction**

2.1.1 All steel used in construction of body **shall** have a 50,000 psi minimum yield strength unless otherwise noted. All body welds **shall** be continuous seam.

2.1.2 Payload Capacity: Body **shall** have a net usable capacity of not less than 24 cubic yards (less hoppers). **Minimum 3 yd rear hopper** capacity and a **minimum 4 yd front hopper** capacity.

### **2.2 Tailgate/Hopper**

2.2.1 The rear opening **shall** be covered by a top hinged tailgate which **shall** be constructed to house the rear packing mechanism and form a **minimum 3 cubic yard hopper**.

2.2.2 Tailgate: Tailgate **shall** be one piece, hinged at top of body. Raising, lowering, and latching of tailgate **shall** be done hydraulically. Tailgate opening **shall** include a rubber seal to prevent liquid seepage.

2.2.3 A rider platform with safety handrails **shall** be provided on each side of the tailgate. The platform **shall** be constructed of self-cleaning, non skid steel grate. Measurements **shall** be 20 inches maximum from ground level, 10 inches wide, and 41 inches long.

2.2.4 The operator **shall** activate the packing mechanism into an automatic cycle or have complete manual control to stop and resume cycle or when a short cycle is desired.

### **2.3 Automated Lifting Arm**

- 2.3.1 Body **shall** be equipped with an automated container lifting mechanism capable of handling 30-110 gallon universal style roll carts as well as square, 90-110 gallon curb side containers. Lifting mechanism **shall** be mounted to service containers on the right (curb) side of truck by a single operator in the right side driver's station.
- 2.3.2 Lifting mechanism **shall** extend, clamp, raise, dump, and return container to original position. Minimum reach (horizontal extension) of 108 inches. **All arm functions shall operate at advertised speed with the truck in gear, engine idling.**
- 2.3.3 Lifting mechanism **shall** be hydraulically operated, with a lifting capacity of not less than 625 lbs. at maximum reach, and **shall** incorporate a self leveling feature to keep the container in a level position when in operation.

## 2.4 Hydraulic System

- 2.4.1 Controls: Automated arm mechanism **shall** be controlled via an electric stick type control operable from inside the right side of truck cab. **No push-pull cable controls will be accepted.** Push button controls for packing mechanism function **shall** be provided inside the truck cab. Controls **shall** be clearly marked as to their function. A warning light **shall** be provided to indicate when the tailgate is not down and latched.
- 2.4.2 Power Take Off: Cab and chassis **shall** be equipped for front mounted, engine driven PTO operation.
- 2.4.3 Overspeed Protection: Each unit **shall** be protected through the transmission. **Electronic overspeed devices will not be accepted.** If hydraulic pump is certified for operation up to the governed RPM of engine an overspeed device is not required provided that a letter of certification from pump manufacturer is included in bid.
- 2.4.4 Hydraulic Pump: **Dixon** brand hydraulic pump **shall** have sufficient capacity to provide full automated arm functions at engine idle speed as well as the ability to provide a pack-on-the-run feature. Hydraulic pump **shall** be warranted by its manufacturer for a period of **not less than three (3) years. No clutches shall be used in PTO/pump system.** Pump **shall** be mounted to allow for ease of maintenance and removal. **Removal of entire front bumper to gain access to pump is not acceptable.**
- 2.4.5 Oil reservoir: Hydraulic oil reservoir **shall** be of sufficient capacity to prevent overheating of oil during normal operation. Reservoir **shall** be mounted behind the cab. Oil reservoir **shall** have appropriate baffling, drain plug, fill port, and sight gauge. A ball valve **shall** be installed to allow removal of plumbing without draining reservoir. Oil reservoir **shall** be equipped with a Pall Reservoir Air Breather part number HC7400SKN4H. No unfiltered venting of the hydraulic system will be permitted. Exterior surface of reservoir **shall** have a black powder coated finish. **Paint finishes will not be accepted.**

2.4.6 Filters: Unit **shall** be equipped with a Pall return line filter assembly using cartridge part number HC8800FKN16H. A pressure differential monitor with “change filter” light **shall** be installed in cab.

2.4.7 Valve Bank: Hydraulic system **shall** have adjustable main relief valve. A pressure gauge measuring main system pressure **shall** be permanently installed in close proximity to main relief adjustment. There also **shall** be manual controls on valves in case of electrical failure.

2.4.8 Hydraulic Plumbing: **Stainless steel tubing shall** be used wherever possible secured by cushioned clamps. All hydraulic hose **shall** meet or exceed SAE 100R2 Type AT requirements. All hose end fittings **shall** be attached by crimped ferrule type. With exception to the main suction hose, no hose clamp connections will be accepted.

2.4.9 Controls: Controls for rear packing mechanism **shall** be located curbside near hopper opening. Controls for ejector system and tailgate lift **shall** be located street side at front of body. A weatherproof pushbutton **shall** be located near packing mechanism controls which activates a buzzer in truck cab.

## **2.5 Roll Cart Dump Units**

2.5.1 Each unit **shall** have two (2) **Bayne Machine Works Inc. Thinline model TL 1116** roll cart lifter units mounted. The units **shall** operate semi-automatically and be mounted so that the entire contents of the roll cart can be dumped into the rear hopper.

2.5.2 Each dump unit **shall** be painted bright yellow.

2.5.3 Dump units **shall** be totally hydraulic, utilizing the refuse body hydraulic system as a power source. The amount of hydraulic flow to the dump units **shall** be mechanically limited to only that which is required to achieve the proper cycle time. ***It shall not be necessary to speed up truck engine to achieve the desired cycle time.*** No electrically actuated diverter valves will be accepted.

2.5.4 Each dump unit **shall** have its own manual control valve mounted adjacent to the hopper. Bayne hand valve assembly number **6083-1025 shall** be used for each flipper. Dump units **shall** be able to operate individually or simultaneously while maintaining proper cycle times.

2.5.5 Complete cycle time of 8-10 seconds. **It must be possible to stop the cycle at any point and reverse direction.**

## **2.6 Miscellaneous**

2.6.1 The frame rails of the truck **shall** not be drilled, cut, or altered in any way other than that approved by the chassis manufacturer.

2.6.2 Anti-sail mud flaps **shall** be installed behind rear wheels. A fixed mud guard **shall** be installed in front of the rear wheels.

2.6.3 Lighting: All lighting required by the Federal Motor Vehicle Safety Standard #108, **shall** be installed. All rear facing stop, turn, or tail lamps **shall** be flush mounted, sealed LED units (such as Grote 53252, or Truck Lite 44982R). All clearance lamps **shall** be 2 ½ inches, grommet mounted, sealed LED units (such as Grote 47122 or Truck Lite 10250R). License plate lamp **shall** be a sealed LED unit (such as Grote 60381 or Truck Lite 15226). Backup lamps **shall** be sealed LED units (such as Truck-Lite 44806C). One (1) Truck Lite 81360 **shall** be used to illuminate the hopper area(s), and one (1) Truck Lite 81360 **shall** be mounted to illuminate the area in front of the ejector panel. Both lights **shall** be controlled by separate switches in truck cab.

2.6.4 Strobe Lights: Two (2) rear facing 4 inches round, grommet mounted, amber strobe lights **shall** be mounted on the tailgate in a manner consistent with other rear facing lights. Strobe lights **shall** be self contained **LED** units (such as Truck Lite 44212Y or Grote 77353). **Strobe box supplied systems will not be accepted.**

2.6.5 Wiring: Any circuit added to the truck **shall** be wired through the truck's fuse panel and protected by fuse or circuit breaker. All connections to a component **shall** be made with a molded plug or otherwise environmentally sealed connector. Individual wires **shall** be terminated with a terminal which is **crimped, soldered, and covered with heat shrink tubing**. Splices should be avoided. If a spliced wire cannot be avoided, the splice **shall** be soldered and covered with heat shrink tubing. ***Under no circumstances will the use of the following items or methods be accepted: crimp-type butt connectors, Scotch-Lok's, solderless terminals, electrical tape, wire nuts, or in-line fuses.***

2.6.6 Painting: Entire body **shall** be thoroughly cleaned of dirt, oil, grease, and welding slag. Cleaned bare metal **shall** be prepped and coated prior to paint finish. Other painting processes may be employed only if expressly approved by the Division of Fleet Services. **No electrical wire, hydraulic hose, or fitting shall be painted.** Body to be metallic gray (DuPont 44400U) with eight inch blue (DuPont 44426U) stripe. Paint diagram will be provided by LFUCG.

2.6.7 Safety Equipment: A 10 lb. fully rechargeable, A-B-C fire extinguisher **shall** be mounted on the outside of the driver's side of packer body in a convenient location. A set of reflecting safety triangles **shall** be provided.

2.6.8 **All switches and controls shall be clearly marked as to their function.**

2.6.9 Back-Up Vision System: **"Safety Vision Brand"** closed circuit rear/side vision system number **SV-CLCD70B** utilizing four (4) color cameras **shall** be installed with a multi-input seven inch (7") color LCD monitor positioned for convenient viewing by driver. Cameras **shall** provide a view of the area immediately behind the vehicle to aid in backing, a view of the automated arm action, inside hopper, and a view of traffic on the left side of the vehicle. System **shall** automatically switch to the rear view when truck

## II. Bid Conditions

- A. No bid may be withdrawn for a period of sixty (60) days after the date and time set for opening.
- B. No bid may be altered after the date and time set for opening. In the case of obvious errors, the Division of Central Purchasing may permit the withdrawal of a bid. The decision as to whether a bid may be withdrawn shall be that of the Division of Central Purchasing.
- C. Acceptance of this proposal shall be enactment of an Ordinance by the Urban County Council.
- D. The bidder agrees that the Urban County Government reserves the right to reject any and all bids for either fiscal or technical reasons, and to award each part of the bid separately or all parts to one vendor.
- E. Minor exceptions may not eliminate the bidder. The decision as to whether any exception is minor shall be entirely that of the head of the requisitioning Department or Division and the Director of the Division of Central Purchasing. The Urban County Government may waive technicalities and informalities where such waiver would best serve the interests of the Urban County Government.
- F. Manufacturer's catalogue numbers, trade names, etc., where shown herein are for descriptive purposes and are to guide the bidder in interpreting the standard of quality, design, and performance desired, and shall not be construed to exclude proposals based on furnishing other types of materials and/or services. However, any substitution or departure proposed by the bidder must be clearly noted and described; otherwise, it will be assumed that the bidder intends to supply items specifically mentioned in this Invitation for Bids.
- G. The Urban County Government may require demonstrations of the materials proposed herein prior to acceptance of this proposal.
- H. Bids must be submitted on this form and must be signed by the bidder or his authorized representative. Unsigned bids will not be considered.
- I. Bids must be submitted prior to the date and time indicated for opening. Bids submitted after this time will not be considered.
- J. All bids mailed must be marked on the face of the envelope:

**“Bid on #62-2013 CNG Cab & Chassis for Refuse Vehicles”**

and addressed to:      Division of Central Purchasing  
   200 East Main Street, Room 338  
   Lexington, Kentucky 40507

**The Lexington-Fayette Urban County Government assumes no responsibility for bids that are not addressed and delivered as indicated above. Bids that are not delivered to the Division of Central Purchasing by the stated time and date will be rejected.**

- K. Bidder is requested to show both unit prices and lot prices. In the event of error, the unit price shall prevail.
- L. A certified check or Bid Bond in the amount of XX percent of the bid price must be attached hereto. This check must be made payable to the Lexington-Fayette Urban County Government, and will be returned when the material and/or services specified herein have been delivered in accordance with specifications. In the event of failure to perform within the time period set forth



in this bid, it is agreed the certified check may be cashed and the funds retained by the Lexington-Fayette Urban County Government as liquidated damages. Checks of unsuccessful bidders will be returned when the bid has been awarded.

- M. The delivery dates specified by bidder may be a factor in the determination of the successful bidder.
- N. Tabulations of bids received may be mailed to bidders. Bidders requesting tabulations must enclose a stamped, self-addressed envelope with the bid.
- O. The Lexington-Fayette Urban County Government is exempt from Kentucky Sales Tax and Federal Excise Tax on materials purchased from this bid invitation. Materials purchased by the bidder for construction projects are not tax exempt and are the sole responsibility of the bidder.
- P. All material furnished hereunder must be in full compliance with OSHA regulations.
- Q. If more than one bid is offered by one party, or by any person or persons representing a party, all such bids shall be rejected.
- R. Signature on the face of this bid by the Bidder or his authorized representative shall be construed as acceptance of and compliance with all terms and conditions contained herein.
- S. The Entity (regardless of whether construction contractor, non-construction contractor or supplier) agrees to provide equal opportunity in employment for all qualified persons, to prohibit discrimination in employment because of race, color, creed, national origin, sex or age, and to promote equal employment through a positive, continuing program from itself and each of its sub-contracting agents. This program of equal employment opportunity shall apply to every aspect of its employment policies and practices.
- T. The Kentucky Equal Employment Opportunity Act of 1978 (KRS 45.560-45.640) requires that any county, city, town, school district, water district, hospital district, or other political subdivision of the state shall include in directly or indirectly publicly funded contracts for supplies, materials, services, or equipment hereinafter entered into the following provisions:

During the performance of this contract, the contractor agrees as follows:

- (1) The contractor will not discriminate against any employee or applicant for employment because of race, color, religion, sex, age or national origin;*
- (2) The contractor will state in all solicitations or advertisements for employees placed by or on behalf of the contractors that all qualified applicants will receive consideration for employment without regard to race, color, religion, sex, age or national origin;*
- (3) The contractor will post notices in conspicuous places, available to employees and applicants for employment, setting forth the provisions of the non-discrimination clauses required by this section; and*
- (4) The contractor will send a notice to each labor union or representative of workers with which he has a collective bargaining agreement or other contract or understanding advising the labor union or workers' representative of the contractor's commitments under the nondiscrimination clauses.*

The Act further provides:

KRS 45.610. Hiring minorities - Information required

- (1) For the length of the contract, each contractor shall hire minorities from other sources*

*within the drawing area, should the union with which he has collective bargaining agreements be unwilling to supply sufficient minorities to satisfy the agreed upon goals and timetable.*

- (2) *Each contractor shall, for the length of the contract, furnish such information as required by KRS 45.560 to KRS 45.640 and by such rules, regulations and orders issued pursuant thereto and will permit access to all books and records pertaining to his employment practices and work sites by the contracting agency and the department for purposes of investigation to ascertain compliance with KRS 45.560 to 45.640 and such rules, regulations and orders issued pursuant thereto.*

KRS 45.620. Action against contractor - Hiring of minority contractor or subcontractor

- (1) *If any contractor is found by the department to have engaged in an unlawful practice under this chapter during the course of performing under a contract or subcontract covered under KRS 45.560 to 45.640, the department shall so certify to the contracting agency and such certification shall be binding upon the contracting agency unless it is reversed in the course of judicial review.*
- (2) *If the contractor is found to have committed an unlawful practice under KRS 45.560 to 45.640, the contracting agency may cancel or terminate the contract, conditioned upon a program for future compliance approved by the contracting agency and the department. The contracting agency may declare such a contractor ineligible to bid on further contracts with that agency until such time as the contractor complies in full with the requirements of KRS 45.560 to 45.640.*
- (3) *The equal employment provisions of KRS 45.560 to 45.640 may be met in part by a contractor by subcontracting to a minority contractor or subcontractor. For the provisions of KRS 45.560 to 45.640, a minority contractor or subcontractor shall mean a business that is owned and controlled by one or more persons disadvantaged by racial or ethnic circumstances.*

KRS 45.630 Termination of existing employee not required, when

*Any provision of KRS 45.560 to 45.640 notwithstanding, no contractor shall be required to terminate an existing employee upon proof that that employee was employed prior to the date of the contract.*

KRS 45.640 Minimum skills

*Nothing in KRS 45.560 to 45.640 shall require a contractor to hire anyone who fails to demonstrate the minimum skills required to perform a particular job.*

It is recommended that all of the provisions above quoted to be included as special conditions in each contract. In the case of a contract exceeding \$250,000, the contractor is required to furnish evidence that his work-force in Kentucky is representative of the available work-force in the area from which he draws employees, or to supply an Affirmative Action plan which will achieve such representation during the life of the contract.

- U. Any party, firm or individual submitting a proposal pursuant to this invitation must be in compliance with the requirements of the Lexington-Fayette Urban County Government regarding taxes and fees before they can be considered for award of this invitation and must maintain a "current" status with regard to those taxes and fees throughout the term of the contract. The contractor must be in compliance with Chapter 13 from the Code of Ordinances

of the Lexington-Fayette Urban County Government. The contractor must be in compliance with Ordinance 35-2000 pursuant to contractor registration with the Division of Building Inspection. If applicable, said business must have a Fayette County business license.

Pursuant to KRS 45A.343 and KRS 45A.345, the contractor shall

- (1) *Reveal any final determination of a violation by the contractor within the previous five year period pursuant to KRS Chapters 136 (corporation and utility taxes), 139 (sales and use taxes), 141 (income taxes), 337 (wages and hours), 338 (occupational safety and health of employees), 341 (unemployment and compensation) and 342 (labor and human rights) that apply to the contractor; and*
- (2) *Be in continuous compliance with the above-mentioned KRS provisions that apply to the contractor for the duration of the contract.*

A contractor's failure to reveal the above or to comply with such provisions for the duration of the contract shall be grounds for cancellation of the contract and disqualification of the contractor from eligibility for future contracts for a period of two (2) years.

- V. Vendors who respond to this invitation have the right to file a notice of contention associated with the bid process or to file a notice of appeal of the recommendation made by the Director of Central Purchasing resulting from this invitation.

Notice of contention with the bid process must be filed within 3 business days of the bid/proposal opening by (1) sending a written notice, including sufficient documentation to support contention, to the Director of the Division of Central Purchasing or (2) submitting a written request for a meeting with the Director of Central Purchasing to explain his/her contention with the bid process. After consulting with the Commissioner of Finance the Chief Administrative Officer and reviewing the documentation and/or hearing the vendor, the Director of Central Purchasing shall promptly respond in writing findings as to the compliance with bid processes. If, based on this review, a bid process irregularity is deemed to have occurred the Director of Central Purchasing will consult with the Commissioner of Finance, the Chief Administrative Officer and the Department of Law as to the appropriate remedy.

Notice of appeal of a bid recommendation must be filed within 3 business days of the bid recommendation by (1) sending a written notice, including sufficient documentation to support appeal, to the Director, Division of Central Purchasing or (2) submitting a written request for a meeting with the Director of Central Purchasing to explain his appeal. After reviewing the documentation and/or hearing the vendor and consulting with the Commissioner of Finance and the Chief Administrative Officer, the Director of Central Purchasing shall in writing, affirm or withdraw the recommendation.

### III. Procurement Contract Bid Conditions

- A. The terms of this agreement shall be for 1 year from the date of acceptance of this contract by the Lexington-Fayette Urban County Government. This agreement may be extended for an additional 1 year renewal upon the written agreement of the bidder and the Lexington-Fayette Urban County Government. Said agreement must be in writing and must be executed prior to the expiration of the current agreement.
  
- B. Price Changes (**Space Checked Applies**)
  - (XXX) 1. Prices quoted in response to the Invitation shall be firm prices for the first 180 days of the Procurement Contract. After 180 days, prices may be subject to revision and such changes shall be based on general industry changes. Revision may be either increases or decreases and may be requested by either party. There will be no more than one (1) price adjustment per six month period. Requests for price changes shall be received in writing at least twenty (20) days prior to the effective date and are subject to written acceptance before becoming effective. Proof of the validity of a request for revision shall be responsibility of the requesting party. The Lexington-Fayette Urban County Government shall receive the benefit of any decline that the seller shall offer his other accounts.
  
  - () 2. No provision for price change is made herein. Prices are to be firm for the term of this contract.
  
  - () 3. Procurement Level Contract
  
- C. If any contract item is not available from the vendor, the Lexington-Fayette Urban County Government, at its option, may permit the item to be back-ordered or may procure the item on the open market.
  
- D. All invoices must bear reference to the Lexington-Fayette Urban County Government Purchasing document numbers which are being billed.
  
- E. This contract may be canceled by either party thirty (30) days after delivery by canceling party of written notice of intent to cancel to the other contracting party.
  
- F. This contract may be canceled by the Lexington-Fayette Urban County Government if it is determined that the Bidder has failed to perform under the terms of this agreement, such cancellation to be effective upon receipt of written notice of cancellation by the Bidder.
  
- G. No substitutions for articles specified herein may be made without prior approval of the Division of Central Purchasing.

## GENERAL PROVISIONS OF BID CONTRACT

By signing the below, bidder acknowledges that it understands and agrees with the following provisions related to its bid response and the provision of any goods or services to LFUCG upon selection by LFUCG pursuant to the bid request:

1. Bidder shall comply with all Federal, State & Local regulations concerning this type of service or good.
2. Failure to submit ALL forms and information required by LFUCG may be grounds for disqualification.
3. Addenda: All addenda, if any, must be considered by the bidder in making its response, and such addenda shall be made a part of the requirements of the bid contract. Before submitting a bid response, it is incumbent upon bidder to be informed as to whether any addenda have been issued, and the failure of the bidder to cover any such addenda may result in disqualification of that response.
4. Bid Reservations: LFUCG reserves the right to reject any or all bid responses, to award in whole or part, and to waive minor immaterial defects in proposals. LFUCG may consider any alternative proposal that meets its basic needs.
5. Liability: LFUCG is not responsible for any cost incurred by bidder in the preparation of its response.
6. Changes/Alterations: Bidder may change or withdraw a proposal at any time prior to the opening; however, no oral modifications will be allowed. Only letters, or other formal written requests for modifications or corrections of a previously submitted proposal which is addressed in the same manner as the bid response, and received by LFUCG prior to the scheduled closing time for receipt of bids, will be accepted. The bid response when opened, will then be corrected in accordance with such written request(s), provided that the written request is contained in a sealed envelope which is plainly marked "modifications of bid response".
7. Clarification of Submittal: LFUCG reserves the right to obtain clarification of any point in a bid or to obtain additional information from any bidder.
8. Bribery Clause: By his/her signature on its response, bidder certifies that no employee of his/hers, any affiliate or subcontractor, has bribed or attempted to bribe an officer or employee of the LFUCG.
9. Additional Information: While not necessary, the bidder may include any product brochures, software documentation, sample reports, or other documentation that may assist LFUCG in better understanding and evaluating the bid response. Additional documentation shall not serve as a substitute for other documentation which is required by the LFUCG to be submitted with the bid response.
10. Ambiguity, Conflict or other Errors: If a bidder discovers any ambiguity, conflict, discrepancy, omission or other error in the bid request of LFUCG, it shall immediately notify LFUCG of such error in writing and request modification or clarification of the document if allowable by the LFUCG.

11. Agreement to Bid Terms: In submitting its bid response, the bidder agrees that it has carefully examined the specifications and all provisions relating to LFUCG's bid request, including but not limited to the bid contract. By submission of its bid response, bidder states that it understands the meaning, intent and requirements of LFUCG's bid request and agrees to the same. The successful bidder shall warrant that it is familiar with and understands all provisions herein and shall warrant that it can comply with them. No additional compensation to bidder shall be authorized for services, expenses, or goods reasonably covered under these provisions that the bidder omits from its bid response.
12. Cancellation: LFUCG may unilaterally terminate the bid contract with the selected bidder(s) at any time, with or without cause, by providing at least thirty (30) days advance written notice unless a different advance written notice period is negotiated prior to contract approval. Payment for services or goods received prior to termination shall be made by the LFUCG provided these goods or services were provided in a manner acceptable to the LFUCG. Payment for those goods and services shall not be unreasonably withheld.
13. Assignment of Contract: The selected bidder(s) shall not assign or subcontract any portion of the bid contract with LFUCG without the express written consent of LFUCG. Any purported assignment or subcontract in violation hereof shall be void. It is expressly acknowledged that LFUCG shall never be required or obligated to consent to any request for assignment or subcontract; and further that such refusal to consent can be for any or no reason, fully within the sole discretion of LFUCG.
14. No Waiver: No failure or delay by LFUCG in exercising any right, remedy, power or privilege hereunder, nor any single or partial exercise thereof, nor the exercise of any other right, remedy, power or privilege shall operate as a waiver hereof or thereof. No failure or delay by LFUCG in exercising any right, remedy, power or privilege under or in respect of this bid proposal or bid contract shall affect the rights, remedies, powers or privileges of LFUCG hereunder or shall operate as a waiver thereof.
15. Authority to do Business: Each bidder must be authorized to do business under the laws of the Commonwealth of Kentucky and must be in good standing and have full legal capacity to provide the goods or services specified in the bid proposal. Each bidder must have all necessary right and lawful authority to submit the bid response and enter into the bid contract for the full term hereof including any necessary corporate or other action authorizing the bidder to submit the bid response and enter into this bid contract. If requested, the bidder will provide LFUCG with a copy of a corporate resolution authorizing this action and/or a letter from an attorney confirming that the proposer is authorized to do business in the Commonwealth of Kentucky. All bid responses must be signed by a duly authorized officer, agent or employee of the bidder.
16. Governing Law: This bid request and bid contract shall be governed by and construed in accordance with the laws of the Commonwealth of Kentucky. In the event of any proceedings regarding this matter, the bidder agrees that the venue shall be the Fayette County Circuit Court or the U.S. District Court for the Eastern District of Kentucky, Lexington Division and that the bidder expressly consents to personal jurisdiction and venue in such Court for the limited and sole purpose of proceedings relating to these matters or any rights or obligations arising thereunder.
17. Ability to Meet Obligations: Bidder affirmatively states that there are no actions, suits or proceedings of any kind pending against bidder or, to the knowledge of the bidder, threatened



# CHASSIS SPECIFICATIONS SUMMARY

May 16, 2013

## 2014 MACK LEU633

REFUSE SEMI-AUTO SIDE LOADER On/Off Hwy  
STRAIGHT TRUCK WITHOUT TRAILER

<b>Engine</b>	CUMMINS ISL-G 320HP	<b>Transmission</b>	4500-RDS-6
		<b>Clutch</b>	
<b>Front Axle</b>	20,000# FXL20	<b>Rear Axle</b>	46,000# S462 Ratio 5.66
<b>Suspension</b>	20,000#	<b>Suspension</b>	46,000# SS462
<b>Tires</b>	Front: 315/80R22.5 Rear: 12R22.5	<b>Wheels</b>	22.5x9.0 STEEL DISC (10-HOLE) 22.5x8.25 STEEL DISC (10 HOLE)
<b>Ratings</b>	GVW: 66,000#	<b>Fuel Tanks</b>	
<b>Fifth Wheel</b>		<b>Sleeper</b>	

---

**Total Quantity:** 11      **Estimated Total Weight:** 18,061#      **Reference#:** AGBX004714A

---

X \_\_\_\_\_  
**Customer Signature**      **Date**  
 Prepared For:  
 City of Lexington  
  
 Phone: --  
 Fax: --

X \_\_\_\_\_  
**Dealer Signature**      **Date**  
 Presented By:  
 Jim Dotson  
 Worldwide Equipment  
  
 Lexington, Kentucky 40511  
 859-797-1434  
 jim.dotson@thetruckpeople.com



**Prepared For:**  
City of Lexington

**Presented By:**  
Worldwide Equipment  
945 Nandino Blvd  
Lexington, Kentucky 40511  
859-797-1434  
jim.dotson@thetruckpeople.com

Page 1

May 16, 2013  
2014 LEU633  
Ref#: AGBX004714A

Description		Front Wt	Rear Wt.
<b>ORDER/CUSTOMER/VEHICLE INFORMATION</b>			
INITIAL REGISTRATION LOCATION, UNITED STATES, KENTUCKY	Opt		
IDLE EMISSION CERTIFICATION, IDLE EMISSION CERTIFICATION - BASIC	Std		
TYPE OF SERVICE, MUNICIPAL	Opt		
VEHICLE APPLICATION CLASS, HEAVY VOCATIONAL - Unlimited operation on concrete, asphalt, or maintained gravel/packed dirt with a maximum 3% grade; limited operation on unmaintained surfaces with maximum 5% grade; limited operation on concrete, asphalt, or maintained gravel/packed dirt with maximum 10% grade. (3 AXLES) 78,000 lbs (35,281 kg) MAX GVW. (4 AXLES) 80,000 lbs (36,288 kg) MAX GVW.	Opt		
CARRIER APPLICATION, WITH CRD150-151. Unlimited miles on 3% grade maintained gravel/packed dirt or paved, Max 15% miles on 10% grade maintained gravel/packed dirt or paved, Max 10% miles on 5% unmaintained, maintained gravel, packed dirt, or paved. 90000# (41000 kg) MAX GCW. (Carrier Code USA-V1)	Std		
VEHICLE TYPE, STRAIGHT TRUCK WITHOUT TRAILER	Std		
VEHICLE USE AND BODY/TRAILER TYPE, REFUSE SEMI-AUTO SIDE LOADER On/Off Hwy			
COMMODITIES, REFUSE			
FILE STATUS, QUOTE			
PRICE BOOK LEVEL, 2014A PRICE BOOK LEVEL	Std		
PRODUCT TYPE, PRODUCT TYPE - OL64R TRUCK	Opt		
PRODUCT CLASS, PRODUCT CLASS 29	Opt		
BACK OFFICE PROCESS, BACK OFFICE PROCESS	Std		
<b>BVS/WHEELBASE/PLATFORM</b>			
CHASSIS (BASE MODEL), LEU633 6-WHEEL TRUCK	Std	10533	6997
SPECIAL SALES PACKAGE, DUAL SIT DOWN DRIVE PACKAGE W/BOSTROM SEATS	Opt	300	
FRAME RAILS, 13.375" x 3.25" x .375" (340 x 83 x 10mm ) STEEL Section Modulus 23.49 cu in/RBM 2,818,800 in lbs per rail.	Std		
WHEELBASE, 210" (5334 mm) WB 219" CA (5563 mm)	Inc		
PLATFORM, 286" LP (7264 mm) 67" AF (1694 mm) USED WITH 210" WB	Opt		
FRAME REINFORCEMENT - INSIDE, 1/4" STEEL INSIDE CHANNEL REINFORCEMENT	Opt		
<b>ENGINE/TRANSMISSION/CLUTCH</b>			
ENGINE, CUMMINS ISL-G 320 HP @2000 RPM (PEAK) 1000 LB FT. MAX TORQUE @ 1300 RPM	Std		
TRANSMISSION, 6 SPEED AUTOMATIC, ALLISON 4500-RDS-6 (4.70/0.67) RUGGED DUTY SERIES GEN 4 INCLUDES DIRECT MOUNT OIL COOLER, EXTERNAL OIL COOLER, INTERNAL FILTER, AND OIL LEVEL SENSOR	Std		
<b>EXHAUST/EMISSIONS</b>			
EXHAUST, NO MUFFLER, SINGLE (R/S) VERTICAL STRAIGHT EXHAUST STACK PLAIN END, SIDE OUTLET DIFFUSER, OUTBOARD	Std		
<b>ENGINE EQUIPMENT</b>			
AIR COMPRESSOR, CUMMINS TWIN 30.4 CFM	Std		
PRE-CLEANER (DRY TYPE CLEANER)	Std		
ALTERNATOR, DELCO 12V 160A (24SI)	Std		
<b>BATTERIES, (3) MACK 12V 1000/3000 CCA THREADED STUD</b>	Opt	17	4
TEXACO EXTENDED LIFE COOLANT #7998 W/NITRITES (50/50 MIX) TO -34 DEG	Std		



Description		Front Wt	Rear Wt
COOLING PERFORMANCE, AUX COOLER	USR	0	0
ENGINE BLOCK HEATER, CUMMINS 120V/1000W	Std		
ENGINE HOSES AND TUBING, SILICONE (DOES NOT INCLUDE HEATER & RADIATOR HOSES)	Std		
FAN DRIVE, HORTON DM 2 SPEED FAN	Std		
FLYWHEEL HOUSING, ALUMINUM	Std		
FUEL-WATER SEPARATOR, CUMMINS CNG COALESCING FUEL FILTER, STANCHION MTD ON FRAME	Std		
HOSES - RADIATOR/HEATER, SILICONE	Std		
STARTER, 12 VOLT DELCO 39MT-MXT	Std		
ELECTRONIC STARTER INTERLOCK	Std		
TETHER DEVICE, PLASTIC COATED CABLE, MOUNTED FRONT OF EACH BATTERY BOX LENGTH TO ALLOW COVER TO SET ON GROUND	Std		
<b>CLUTCH/TRANS EQUIPMENT/DRIVELINES</b>			
REMOTE MTD OIL COLLER FURNISH FOR ALLISON TRANSMISSION	Std		
SYNTHETIC LUBRICANT - TRANSMISSION, TRANSYND SYNTHETIC LUBE FOR ALLISON TRANS	Std		
VOCATIONAL PACKAGE - ALLISON, ALLISON VOCATIONAL PKG. #105183 RUGGED DUTY SERIES (RDS) - (AG) - DUAL SELECTOR W/O GEAR SP LIMITS BOTH SIDES	Inc		
W/O DRIVESHAFT GUARD	Std		
DRIVELINE - MAIN, MERITOR 17 MXL "XTENDED LUBE"	Std		
DRIVELINE - INTERAXLE, MERITOR 17 MXL "XTENDED LUBE"	Std		
<b>CAB (A thru G)</b>			
AIR CONDITIONING, ROOF MOUNTED A/C AND INTEGRAL CAB HEATER DEFROSTER WITH SANDEN ROTARY COMPRESSOR	Opt	93	
AIR CONDITIONING COMPRESSOR, SANDEN ROTARY	Inc		
AIR RESTRICTION MONITOR (INTAKE), GRADUATED LOCK UP (AIR CLEANER INTAKE MOUNTED)	Std		
ASH TRAY, (1) W/HINGED COVER (LOCATED ON TOP OF CONSOLE)	Std		
CAB, RH & LH SIT DOWN, DRIVING POSITION	Inc		
CAB MOUNTING, FOUR POINT FIXED TYPE REAR MOUNTED	Std		
CAB LIFT/TILT, LOCATED IN STD LOCATION	Std		
CERTIFIED WEIGHT	Opt		
COAT HOOK (1)	Std		
ENGINE RUNNING ACTIVATED	Std		
DOMELIGHTS, (2) W/SELF-CONTAINED SWITCH (ONE EACH SIDE)	Std		
"LE" LH & RH ROLL-UP WINDOWS; FRT HINGE DOORS	Inc		
ENGINE SHUTOFF, KEY TYPE	Std		
GAUGE, DUAL AIR PRESSURE	Std		
GAUGE, VOLTMETER	Std		
GAUGE, ENGINE COOLANT TEMPERATURE	Std		
GAUGE, ENGINE OIL PRESSURE	Std		
OMIT FUEL GAUGE	Std		
GAUGES, ENGLISH DISPLAY	Std		
GAUGE, ELECTRONIC SPEEDOMETER/ODOMETER PROXIMITY PICK-UP, AND MAGNETIC SENSOR	Std		

Description		Front Wt	Rear Wt
GAUGE, TACHOMETER	Std		
TRANSMISSION GAUGE AND TRANS. OIL HIGH TEMPERATURE LIGHT	Std		
GEAR SHIFT, WITH NEUTRAL-TO-RANGE INHIBIT	Std		
GLASS - CAB WINDOW, SAFETY TINTED WINDSHIELD SIDE AND REAR WINDOWS	Std		
EXTERIOR GRAB HANDLES, ALUMINUM, RH & LH, BEHIND DOOR AND INTERIOR RH AND LH ON WINDSHIELD POST AND RH ON INSTRUMENT PANEL	Std		
GRILLE, STANDARD FINISH	Std		
<b>CAB (H thru R)</b>			
HEATER WITH INTEGRAL DEFROSTER	Std		
HORN - AIR, (1) TWIN-UNDER CAB TRUMPET W/DUAL LANYARD CONTROL	Std		
HORN - ELECTRIC, DUAL TONE (TWO HORNS)	Opt	1	
IDENTIFICATION/CLEARANCE LIGHTS, (7) MARKER AND CLEARANCE	Std		
INTERIOR TRIM - (SILVER GRAY VINYL)	Std		
CHASSIS KEYED AT RANDOM - 2 KEYS	Std		
LOW AIR PRESSURE INDICATOR LIGHT AND BUZZER	Std		
MIRRORS - EXTERIOR, MOTO MIRROR, RH/LH MOTORIZED AND HTD (S.S) RETRACTABLE ARMS AND BRACKETS RH/LH DOOR MTD	Inc		
MIRRORS - CONVEX TYPE, BRIGHT FINISH, LH & RH 8.0" DIA. MOUNTED BELOW LOWER ARM OF WEST COAST MIRROR	Opt	2	
MUD FLAPS, 12" FRONT FENDER MOUNTED	Std		
PARKING BRAKE CONTROL W/WARNING LIGHT	Std		
AM/FM STEREO CD W/WEATHERBAND	Std		
RADIO ANTENNA, CH STYLE COWL MOUNTED ON LH SIDE	Std		
5-WAY BINDING POSTS FOR CB	Std		
REAR WINDOW (FIXED TYPE)	Std		
<b>CAB (S thru Z)</b>			
SEAT - DRIVER, (2) BOSTROM TALLADEGA 910 (MID-BACK) AIR SUSPENSION	Inc		
SEAT - RIDER, OMIT RIDER SEAT	Inc		
SEAT COVERING, ALL CLOTH, BLACK, DRIVER SEATS	Inc		
LAP & SHOULDER BELTS FOR (2) DRIVER SEATS, TO BE ORANGE IN COLOR	Inc		
DRIVER'S SEAT ONLY	Inc		
SIDE MARKERS, LAMPS AND REFLECTORS TO MEET OR EXCEED FEDERAL REGULATIONS	Std		
STARTER SWITCH, KEY TYPE	Std		
STEERING COLUMN, FIXED	Std		
SUN VISOR - INTERIOR, BOTH SIDES	Std		
TURN SIGNALS, FRONT	Std		
TURN SIGNAL SWITCH, MANUAL CANCELLING TURN SIGNALS	Std		
VENTILATION - CAB, FURNISH LH & RH DOOR VENTS	Inc		
WINDSHIELD PROTECTOR, FURNISH	Opt	15	
WINDSHIELD WASHERS, ELECTRIC, WIPER MOUNTED W/7 QT (6.6 L) RESERVOIR	Std		
WINDSHIELD WIPERS, SPRAGUE-2 SPD ELECTRIC MOTOR W/INTERMITTENT FEATURE	Std		
<b>FRAME EQUIPMENT/FUEL TANKS</b>			
BUMPER - FRONT, PAINTED STEEL FLUSH MTD 59"/1488 mm BBC (CORP 94" x 15.5")	Std		
CROSSMEMBERS, STEEL 1/2" PL BOLTED BOC & INTERMDT 1/8" BELOW RAIL, 1ST XMBR BOC RR 38.17" FROM AL LINE	Std		

Description		Front Wt	Rear Wt
CROSSMEMBER (BEHIND REAR AXLE), W/O OPTIONAL CROSSMEMBERS BEHIND REAR AXLE/BOGIE	Opt	19	-77
FRAME RAIL CLEARANCE, RIGHT-HAND	Inc		
TOWING DEVICE - FRONT, TOW PIN	Std		
TOWING DEVICE - REAR, W/O REAR TOWING DEVICE	Std		
FUEL TANK - LH, DELETE LH FUEL DIESEL TANK - FOR LOCAL COMPLETION & CERTIFICATION OF CNG SYSTEM	Std		
FUEL TANK - RH, DELETE RH DIESEL TANK - FOR LOCAL COMPLETION & CERTIFICATION OF CNG SYSTEM	Std		
FUEL DRAW/RETURN SYSTEM, FLEXIBLE HOSE FOR NATURAL GAS	Std		
RELOCATE FUEL TANK, W/O RELOCATED FUEL TANK(S)	Std		
<b>FRONT AXLE/EQUIPMENT/TIRES</b>			
<b>FRONT AXLES, 20000# (9072kg) MACK FXL20 WIDE PIVOT CENTER</b>	Std		
TIRES BRAND/TYPE - FRONT, MICHELIN - TUBELESS RADIAL PLY, (2) 315/80R22.5 20 L XZUS2 (ALL POSITION)	Opt	6	
WHEELS - FRONT, STEEL DISC (10-HOLE)	Std		
(2) 22.5x9.0 (228 mm) HAYES LEMMERZ 10-HOLE HUB PILOTED (11 1/4"/286mm BC)(FIVE HAND HOLE)(6.42" INSET)	Std		
BRAKES - FRONT, MERITOR "S" CAM TYPE 16.5" x 6" Q+	Opt	1	
BRAKE DRUMS - FRONT, CAST OUTBOARD MOUNTED	Std		
DUST SHIELDS - FRONT BRAKE, OMIT	Std		
HUBS - FRONT, FERROUS	Std		
WITHOUT SHOCK ABSORBERS	Opt		
SLACK ADJUSTERS - FRONT, HALDEX - AUTOMATIC	Opt		
<b>SPRINGS - FRONT, 23,000 FRONT MACK SUSPENSION</b>	USR	0	0
STATIC LOAD CUSHIONS	Std		
STEERING, M100P PLUS RIGHT SIDE ASSIST CYLINDER	Std		
<b>REAR AXLE/EQUIPMENT/TIRES/RATIOS</b>			
<b>REAR AXLE/SUSPENSION, 46000# (20866kg) MACK S462 (268 1020) CAST DUCTILE IRON HOUSING, SS462 MACK MULTILEAF (CAMELBACK) 46000#</b>	Std		
4S/4M SYSTEM REAR WHEEL END SENSORS	Std		
TIRES BRAND/TYPE - REAR, GOODYEAR - TUBELESS RADIAL PLY, (8) 12R22.5 16 H G287MSA (ALL POS)	Opt		168
CARRIER/RATIO - REAR AXLE, CRDP150/151, 5.66 RATIO	Opt		
WHEELS - REAR, STEEL DISC (10 HOLE)	Std		
(8) 22.5x8.25 (210 mm) HAYES LEMMERZ 10-HOLE HUB PILOTED (11 1/4"/286 mm BC) (TWO HAND HOLE)	Std		
BRAKES - REAR, MERITOR "S" CAM 16.5"x7" Q+	Opt		-18
BRAKE DIAPHRAGMS, W/O BRAKE DIAPHRAGM OPTION	Std		
BRAKE DRUMS - REAR, CAST OUTBOARD MOUNTED	Std		
DUST SHIELDS - REAR BRAKE, OMIT	Std		
HUBS - REAR, FERROUS	Inc		
OIL SEALS, STEMCO (VOYAGER)	Std		
HIGH MOUNT REAR BRAKE CHAMBERS (REAR REAR AXLE ONLY)	Std		
SHOCK INSULATORS, HEAVY DUTY URETHANE	Std		
SLACK ADJUSTERS - REAR, HALDEX - AUTOMATIC	Opt		

Description	Front Wt	Rear Wt
SUSPENSION - AXLE SPACING, 50" AXLE SPACING (BOGIE WHEELBASE)		Std
W/O ANTI-SPRINGS		Std
SPRING BRAKE CHAMBERS - QUANTITY, (4) CHAMBERS		Std
SPRING BRAKE CHAMBERS - VENDOR, MGM MODEL TR-T (TAMPER RESISTANT)		Std
SPRING BRAKE CHAMBERS, TYPE 30/30 REAR		Std
TRANSVERSE TORQUE ROD (REAR AXLE ONLY)		Std
BRONZE TRUNNION BUSHING		Inc
<b>AIR/BRAKE</b>		
AIR LINES (CHASSIS), EXTRUDED NYLON TUBING (1/8" & 1/4" LINES ARE SINGLE EXTRUSION; 3/8" AND LARGER HAVE POLYESTER REINFORCED CENTER)		Std
AIR BRAKE SYSTEM, DUAL		Std
AIR DRYER, MERITOR/WABCO AIR DRYER, 1800 HEATED W/COALESCING OIL FILTER		Std
AIR RESERVOIRS, STEEL		Std
ANTI-LOCK BRAKE SYSTEM, BENDIX ABS		Std
AIR CONTROL VALVES - VENDOR, BENDIX SWITCHES AND VALVES WHERE POSSIBLE		Inc
DRAIN VALVES, AUTOMATIC DRAIN VALVE, HEATED ON SUPPLY TANK, MANUAL (PETCOCK) ON ALL OTHER TANKS		Std
<b>ELECTRICAL</b>		
BACK-UP ALARM, PRECO, MODEL 1059		Std
BATTERY BOX(ES), STEEL BASE		Std
BATTERY BOX COVERS, MOLDED PLASTIC		Std
BATTERY BOX - MOUNTING, SINGLE BOX 3 BATTERY MAX. PERP TO FRAME 11" FROM NTOF		Std
FLAMING RIVER BIG SWITCH WIRED ON POSITIVE SIDE		Std
BATTERY SWITCH WARNING LIGHT, FURNISH ON OR NEAR BATTERY BOX (LIGHT ON IN RUN POSITION)		Std
COMPUTER AND 2-WAY RADIO DEDICATED CIRCUIT		Std
ELECTRIC CIRCUIT PROTECTION PACKAGE, 12 VOLT W/CIRCUIT BREAKERS (HEADLAMP CIRCUIT: SAE TYPE I; ALL OTHER CIRCUITS SAE TYPE II) NEGATIVE GROUND SYSTEM		Std
WATERPROOF ELECTRICAL CONNECTIONS SPRAYED W/PROTECTIVE COATING		Std
CONTROL LINK II REFUSE BODYBUILDER ELECTRICAL CONNECTION SYSTEM		Std
HEADLIGHTS, (2) SINGLE ROUND HALOGEN LAMPS		Std
REAR LIGHTING, BRAKE LIGHTS CIRCUIT ACTIVATED WHEN SPRING BRAKES ARE APPLIED AND KEY IN RUN POSITION-NO TAIL LIGHTS		Std
SIGNAL FLASHER TYPE, KYSOR #1039-07732-10 W/PACKARD 3 PIN SEALED CONNECTOR MOUNTED ON STEERING COLUMN NEAR BOTTOM OF DASH		Std
W/O PWR TERMINAL-STROBE LIGHT OPTION		Std
<b>PAINT</b>		
PAINT - CAB EXTERIOR, SINGLE COLOR, BRIGHT BLUE METALLIC [PPG: P3182]		
PAINT - CAB, URETHANE CLEAR COAT		Inc
PAINT CHARGE FOR METALLIC TYPE PAINT		Opt
<b>PAINT - CHASSIS RUNNING GEAR, MACK BLACK (URETHANE)</b>		Std
PAINT - BUMPER, SAME AS CHASSIS RUNNING GEAR		Inc
PAINT - FRONT SPOKE WHEELS, WITHOUT OPTIONAL SPOKE WHEEL PAINT		Std
WITHOUT OPTIONAL SPOKE WHEEL PAINT		Inc
FRONT WHEELS PRE-FINISHED WHITE		Std

Description		Front Wt	Rear Wt
REAR WHEELS PRE-FINISHED WHITE	Std		
<b>PAINT PROCESS CODES</b>			
SAME COLOR AS CHASSIS RUNNING GEAR (5ZB-A1X)	Inc		
<b>CHASSIS RUNNING GEAR - STD COLOR (MACK BLACK) (6AB-Z1X)</b>	Inc		
W/O PAINT FOR FUEL TANK (7HB-Z1X)	Inc		
W/O CUSTOM PAINT FOR HUB&DRUM/SPOKES (5YB-Z1X)	Inc		
W/O CUSTOM PAINTED FRONT/REAR RIM/WHEEL (6BB-Z1X)	Inc		
<b>PTO/SPECIALTY/ADDITIONAL EQUIPMENT</b>			
PTO - CRANKSHAFT ADAPTER, CRANKSHAFT ADAPTER	USR	0	0
FURNISH TC521 FOR USE W/ALLISON (HD, RDS) TRANSMISSION	Std		
W/O WORK BRAKE	Inc		
PUMP MOUNTING BRACKES		0	0
<b>V-MAC IV PROGRAMMABLE PARAMETERS</b>			
CUSTOMER VEHICLE LIMITING SPEED (MPH) 65 mph			
PEDAL ROAD SPEED LIMITER (MPH) 65 mph			
LGVLS FEATURE ACTIVATION Omit			
LOWER GEAR VEHICLE LIMITING SPEED (MPH) 00 mph			
SOFT RSL Omit			
PDLO ENGAGED VLS FEATURE Furnish			
PDLO ENGAGED VEHICLE LIMITING SPEED 00 rpm			
CRUISE CONTROL SETTINGS WITH ALLISON TRANS	Std		
CRUISE CONTROL MAX SET SPEED (MPH) 65 mph			
CRUISE CONTROL MIN SET SPEED (MPH) 20 mph			
CRUISE CONTROL AUTORESUME W/CLUTCH Omit			
CRUISE'N BRAKE ENGAGEMENT DELAY (MPH) 0 mph			
ENGINE OVERSPEED COMPANY LIMIT (RPM) 2200 rpm			
FUELED ENGINE OVERSPEED COMPANY LIMIT (RPM) 2100 rpm			
VEHICLE OVERSPEED COMPANY LIMIT (MPH) 75 mph			
FUELED VEHICLE OVERSPEED COMPANY LIMIT (MPH) 70 mph			
IDLE LOGGING DELAY (MIN) 2			
Monthly Trip Summary			
PERIODIC TRIP HOUR OF DAY 0 (disable)			
PERIODIC TRIP DAY OF WEEK 0 (disable)			
PERIODIC TRIP DAY OF MONTH 1			
EHT MAX ENGINE SET SPEED (RPM)			
2100 rpm			
EHT MIN ENGINE SET SPEED (RPM) 700 rpm			
EHT VEHICLE SPEED RANGE LIMIT (MPH) 10 mph			
EHT RAMP RATE (RPM/Sec)			
EHT SINGLE SPEED CONTROL ACTIVATION Omit			
EHT SINGLE SPEED CONTROL SET SPEED (RPM) 0000 rpm			
EHT JUMP-TO-MIN SET SPEED Omit			
EHT HOLD TO NEAREST RPM 00 rpm			
EHT ACCEL-DECEL BUMP-UP RPM 00 rpm			
EHT ACCEL-DECEL BUMP-DOWN RPM 00 rpm			
ENGINE PROTECTION - OIL PRESSURE SHUTDOWN Furnish			

Description	Front Wt	Rear Wt
ENGINE PROTECTION - COOLANT LEVEL SHUTDOWN	Omit	
ENGINE PROTECTION - COOLANT TEMP SHUTDOWN	Furnish	
ENGINE PROTECTION - ENGINE OIL TEMP SHUTDOWN	Furnish	
ENGINE PROTECTION TRANS OIL TEMP SHUTDOWN	Furnish	
GOVERNOR TYPE	Min-Max Governor	
ENGINE RPM LIMIT IN UPPER GEARS	0000	
ENGINE HIGH IDLE SPEED IF STOPPED	0000	
ENGINE LOW IDLE SET SPEED (RPM)	700 rpm	
DRIVER LOW IDLE ADJUST FEATURE ACTIVATION	Omit	
SMART IDLE FEATURE ACTIVATION	Omit	
SMART IDLE ELEVATED IDLE RPM TIME (MINS)	10	
IDLE S/D ABS TAMPER CHECK	Omit	
IDLE COOLDOWN FEATURE ACTIVATION	Omit	
IDLE SHUTDOWN FEATURE ACTIVATION	Omit	
IDLE SHUTDOWN TIME (MINS)	10	
IDLE SHUTDOWN WARNING TIME (SECS)	30	
IDLE SHUTDOWN WARM-UP TEMPERATURE (DEG F)	100	
IDLE SHUTDOWN WARM-UP TIMER (MINS)	5	
IDLE S/D OVERRIDE W/EHT	Omit	
IDLE S/D OVERRIDE W/PTO	Furnish	
IDLE S/D OVERRIDE W/ENGINE LOAD	Furnish	
IDLE S/D OVERRIDE % ENGINE LOAD THRESHOLD	00	
IDLE S/D CONTROL W/O Idle Shutdown		
IDLE S/D OVERRIDE LOWER TEMP. THRESHOLD (DEG F)	00	
IDLE S/D OVERRIDE UPPER TEMP. THRESHOLD (DEG F)	00	
MAINTENANCE MONITOR FEATURE ACTIVATION	Furnish	
MAINTENANCE MONITOR OEM DEFAULT INTERVALS MP	Vocational	
MAINTENANCE DUE WARNING PERCENT	90	
PTO 1 MAX ENGINE SET SPEED (RPM)	2100 rpm	
PTO 1 MIN ENGINE SET SPEED (RPM)	600 rpm	
PTO 1 VEHICLE SPEED RANGE LIMIT (MPH)	10 mph	
PTO 1 RAMP RATE (RPM/Sec)	100	
PTO 1 SINGLE SPEED CONTROL ACTIVATION	Omit	
PTO 1 SINGLE SPEED CONTROL SET SPEED (RPM)	1000 rpm	
PTO 1 SINGLE SPEED CONTROL AUTOSET	Omit	
PTO 1 JUMP-TO-MIN SET SPEED	Omit	
PTO 1 VEHICLE LIMITING SPEED (MPH)	60 mph	
PTO 1 HOLD TO NEAREST RPM	00 rpm	
PTO 1 ACCEL-DECEL BUMP-UP RPM	00 rpm	
PTO 1 ACCEL-DECEL BUMP-DOWN RPM	00 rpm	
PTO 2 MAX ENGINE SET SPEED (RPM)	2100 rpm	
PTO 2 MIN ENGINE SET SPEED (RPM)	600 rpm	
PTO 2 VEHICLE SPEED RANGE LIMIT (MPH)	10 mph	
PTO 2 RAMP RATE (RPM/Sec)	100	
PTO 2 SINGLE SPEED CONTROL ACTIVATION	Omit	
PTO 2 SINGLE SPEED CONTROL SET SPEED (RPM)	1000 rpm	

Description	Front Wt	Rear Wt
PTO 2 SINGLE SPEED CONTROL AUTOSET Omit		
PTO 2 JUMP-TO-MIN SET SPEED Omit		
PTO 2 VEHICLE LIMITING SPEED (MPH) 60 mph		
PTO 2 HOLD TO NEAREST RPM 00 rpm		
PTO 2 ACCEL-DECEL BUMP-UP RPM		
PTO 2 ACCEL-DECEL BUMP-DOWN RPM 00 rpm		
SPEED SENSOR TAMPER DETECTION SYSTEM ACTIVATION Furnish		
SPEED SENSOR TAMPER DETECTION TORQUE LIMIT (%) 50		
<b>DEALER INFORMATION</b>		
MANUALS, PEDIGREED PROTECTION PLAN TECH. SERVICE MANUAL PROVIDED	Std	
PILOT INSPECTION, REQUESTED	Opt	
ALLISON EXTENDED WARRANTY		
FACTORY		
MANUALS		
ENGINE EXT WARRANTY		
REAR BRAKE CHAMBERS		
MODIFICATIONS		
STANDARD SHIPPING INSTRUCTIONS	Std	
<b>PERFORMANCE/GRAPHICS/TECH DATA</b>		
AMBIENT TEMPERATURE, 77F (25.0C)	Std	
BACK OF CAB INTERFERENCES, VERTICAL EXHAUST, 34" (762mm) FROM BACK OF CAB	Std	
<b>SOFT PRODUCTS/BULLDOG PROTECTION</b>		

# WARRANTY CERTIFICATE



For detailed **WARRANTY CERTIFICATE** coverage refer to the Trucks Dealer Portal or contact the Warranty Department.

<http://www.trucksdealerportal.com/tdp/master/mastr/warranty/mack/Pages/mackwarranty.aspx>







**Prepared For:**  
City of Lexington

**Presented By:**  
Worldwide Equipment

Lexington, Kentucky 40511  
859-797-1434  
jim.dotson@thetruckpeople.com

May 16, 2013  
14A 1.0  
Ref #: AGBX004714A

## **GVW RATING - 66,000#**

Max Front GAWR	<b>20,000#</b>	Max Rear GAWR	<b>46,000#</b>
Front Axle	<b>20,000#</b>	Rear Axle	<b>46,000#</b>
Front Springs	<b>23,000#</b>	Rear Suspension	<b>46,000#</b>
Front Tires	<b>20,000#</b>	Rear Tires	<b>59,120#</b>
Front Wheels/Rims	<b>20,000#</b>	Rear Wheels/Rims	<b>62,400#</b>

**EVERY  
SKILL.**



**DAVID BROCK**

*Has demonstrated skill & knowledge  
competencies for :*

**ISLG CM2180 / 2007-28Q**

*May 2, 2013*

A handwritten signature in cursive script, appearing to read 'Steve Bonney', written over a horizontal line.

Steve Bonney, Trainer, Cummins Crosspoint

**EVERY  
SKILL.**



**DAVID BROCK**

*Has demonstrated skill & knowledge  
competencies for :*

**ISX12G CM2180 EJ  
2012-35Q**

*May 2, 2013*

A handwritten signature in cursive script that reads 'Steve Bonney'.

*Steve Bonney, Trainer, Cummins Crosspoint*

# MAEK<sup>®</sup>

vocational

## TerraPro

LOW ENTRY  
LEU 633

6x4

- CNG Gas Powered Refuse Vehicle

**ENGINE: CUMMINS WESTPORT ISL G 320**

Horsepower - 320 HP [234 kW] @ 2000 RPM  
Max. Torque - 1000 lb/ft @ 1300RPM  
Engine Type - 4 Cycle, Spark Ignited, Inline 6 Cylinder,  
Turbocharged, Charge Air Cooler (CAC)  
Displacement - 540 cu. in. [8.9 L]  
Air Compressor - CUMMINS Twin 30.4 CFM  
Air Cleaner - 15" Single Element w/Snorkel Intak  
Alternator, Delco 12V 130A (24SI)  
Batteries, (3) Mack 12V 650/1950 CCA Threaded Stud Type  
Coolant Protection, -34°F (-37°C)  
Remote Mounted Oil Cooler  
Engine Block Heater - CUMMINS 120V 1500W  
Silicone Engine Hoses and Tubing  
Fan Drive, Electronically Modulated Type - Horton DM  
2-Speed Fan  
Flywheel Housing, Aluminum  
Silicone Radiator & Heater Hoses  
Starter, 12V Delco 39 MT MXT  
Electronic Starter Interlock  
Battery Box Lid



**TRANSMISSION: ALLISON 4500-RDS-6**

6-Speed Automatic, Ratios: 4.70 Low – 0.67 High  
Includes: Direct Mount Oil Cooler, External Oil Cooler,  
Internal Filter and Oil Level Sensor  
Main Driveline: Meritor 17 MXL "Xtended Lube"  
Interaxle Driveline: Meritor 17 MXL "Xtended Lube"  
TC521 Torque Converter

**REAR AXLE: MACK S462**

46,000 lb Capacity  
Tires – 11R22.5 Duals  
Carrier – CRDP150/151  
Wheels – Steel Disc (8) 22.5 x 8.25 10-Hole Hub Piloted  
Brakes: Meritor "S" Cam 16.5" x 7" Q-Plus w/o Dust  
Shields  
Brake Drums Cast Outboard Mounted  
Rear Wheel Seals  
Raised Rear Brake Chambers

**CAB: LOW ENTRY LH DRIVE w/RH Operating  
Position**

Air Restriction Monitor, Graduated Lock Up Type (Air Cleaner  
Intake Mounted)  
Ash Tray w/Hinged Cover  
Cab Mounting, Four Point Fixed Type  
Cab Tilt, Mounted on RH Fender Bracket  
Cigar Lighter  
Coat Hook  
Dome Lights – 2 w/Self-contained Switch  
Doors – RH Rear Opening Fold Up Door and LH Door w/Roll-  
up Window  
Engine Shutoff – Key Type Control  
Gauges – Dual Air Pressure, Voltmeter, Engine Coolant  
Temperature, Engine Oil Pressure, Fuel Level,  
Speedometer, Tachometer, Transmission Oil Temperature  
Gear Shift w/Neutral-to-Range Inhibit  
Grab Handles, Aluminum RH & LH Behind Door  
Heater w/Integral Defroster  
Horn – (1) Twin Trumpet Mounted Under Cab Single Tone  
w/Snow Shield  
Identification and Clearance Lights (7)  
Interior Trim – Silver Gray Vinyl  
Keys, 2 – Keyed at Random  
Low Pressure Indicator Light and Buzzer  
Exterior Mirrors – LH and RH Motorized w/Heated Retractable  
Arms and Brackets

**AIR/BRAKE**

Air Lines Chassis – Extruded Nylon Tubing  
Dual Air Brake System  
Air Dryer - Heated 1800 w/Coalescing Filter  
Air Reservoirs – Steel  
Bendix Anti-Lock Brake System  
Automatic Drain Valve, Heated

**SPECIALITY EQUIPMENT**

Work Brake

Shock Insulators  
Slack Adjusters – Automatic  
Suspension – SS462 Mack Multileaf 46,000 lb Capacity  
Spring Brake Chambers – (4) 30/30 Double Diaphragm Type  
Mechanical Spring Release  
Transverse Torque Rod (Rear Axle Only)  
Trunnion Bushing

**FRONT AXLE: MACK FXL20**

20,000 lb. Capacity  
Tires – 315/80R22.5  
Wheels – Steel Disc (2) 22.5" x 9.0" 10-Hole Hub Piloted  
Brakes: Meritor "S" Cam 16.5" x 6" Q-Plus w/o Dust Shields  
Brake Drums Cast Outboard Mounted  
Slack Adjusters – Automatic  
Suspension – Mack Taperleaf 20,000 lb. Ground Load Rating  
Static Load Cushions  
Steering – M100P Plus Right Side Assist Cylinder

Front Fender Mounted Mud Flaps  
Parking Brake Control w/Warning Light  
AM/FM Stereo CD w/Weather Band  
CB – 5 way Binding Post  
Rear Window, Fixed  
Driver Seat – Sears Seating C-2 with Fabriform Cushions  
(Mid-Back with Air Suspension) with Black Cloth  
Rider Seat – Mack Fold Up w/ Black Dupont Covering  
Seat Belts – Orange, Lap and  
Shoulder for Driver/Lap for  
Fold Up Rider Seat  
Side Markers – Lamps and  
Reflectors  
Key Type Starter Switch  
Steering Column, Fixed  
Sun Visor, Interior Both Sides  
Turn Signal Switch, Manual  
Cancelling  
Ventilation – LH Door Vent  
Windshield Protector  
Windshield Washers – Wiper Mounted with 7qt Reservoir  
Windshield Wipers – 2 Speed Electric Motor w/Intermittent Feature  
Safety Tinted Windshield w/Non-Tinted Side and Rear Windows  
Paint – Mack White (Cab), Mack Black (Chassis Running Gear)

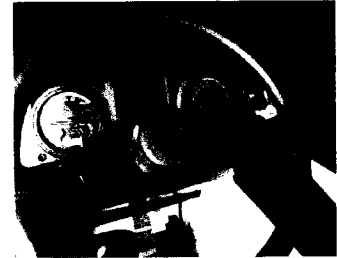
**ELECTRICAL**

12 Volt Electrical System  
Backup Alarm – Preco Model 1059  
Battery Box – Painted Steel w/Locking Tab  
Battery Disconnect Switch, Mtd. RH Side of Battery Box  
Battery Switch Warning Light  
Daytime Running Lights  
Electric Circuit Protection Package  
Waterproof Electrical Connections  
Control Link II  
Headlights – (2) Single Round Halogen Lamps  
Rear Lighting  
Single Flasher, Kysor

(All measurements are in inches)

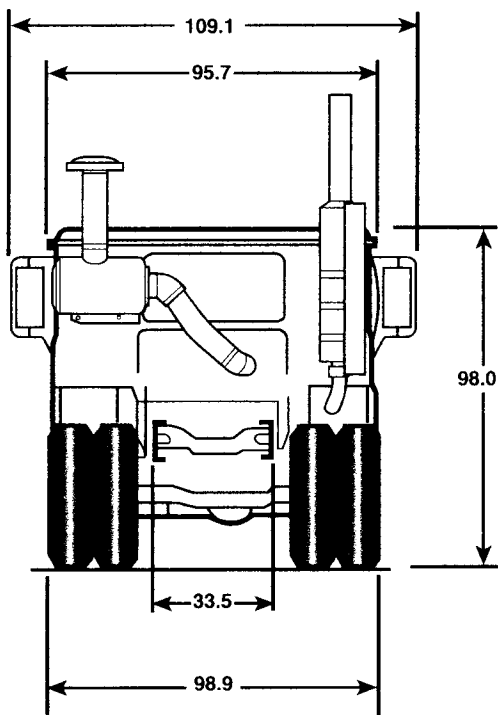
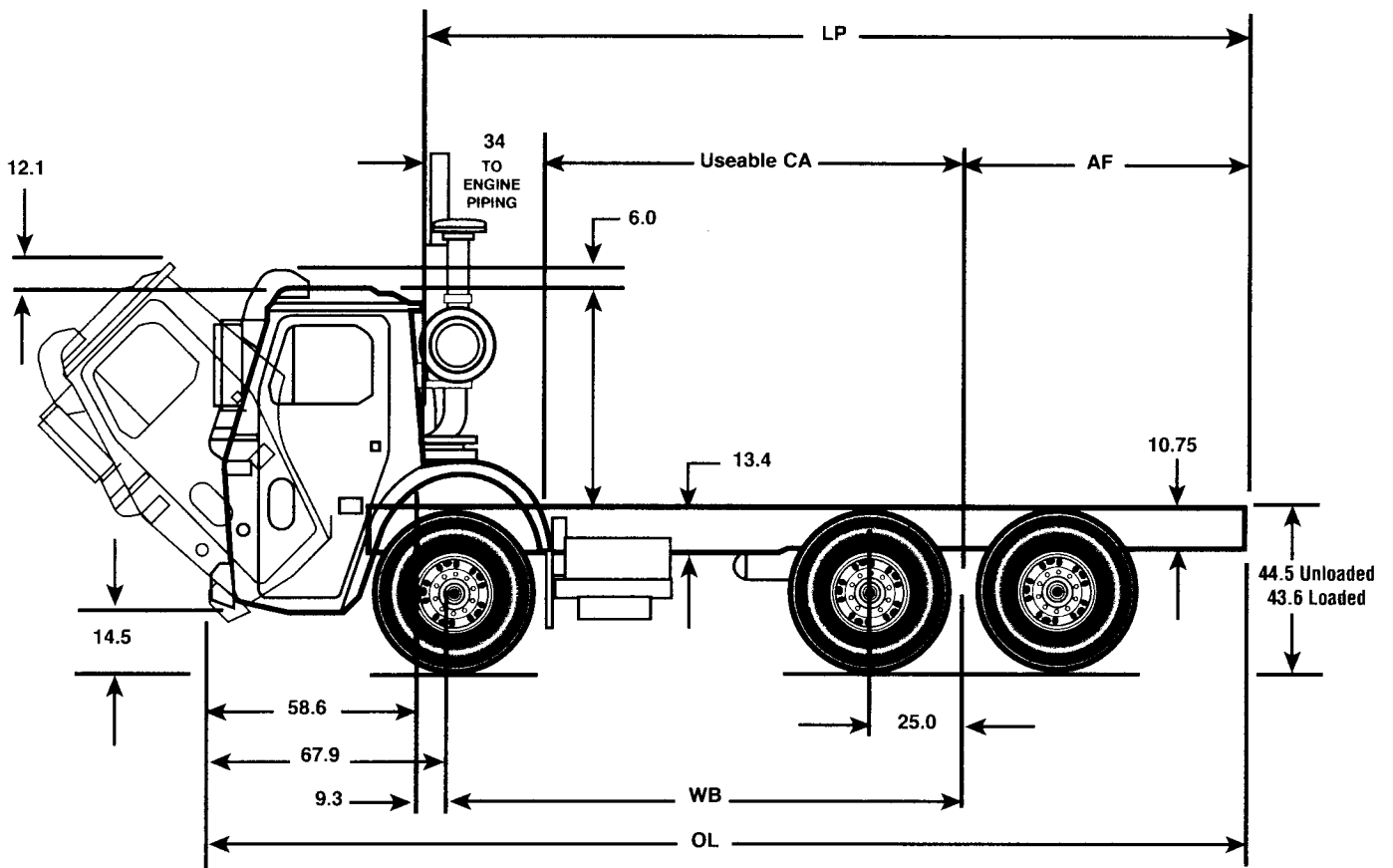

**FRAME**

Frame Rails - 13.38" x 3.25" x .38" Steel  
 Section Modulus, 23.49 in.<sup>3</sup>  
 RBM (per rail) - 2,818,800 lb. in.  
 Bumper - Painted Steel Flush Mounted  
 Bumper to Back of Cab (BBC) - 59"  
 Crossmembers - 1/2" Plate Type Bolted Back of Cab Intermediate 1/8"  
 Below Rail  
 Front Tow Pin

**STANDARD WHEELBASE/LOAD PLATFORM**

For standard wheelbase and load platform information refer to your current version of MACKTRAQ®

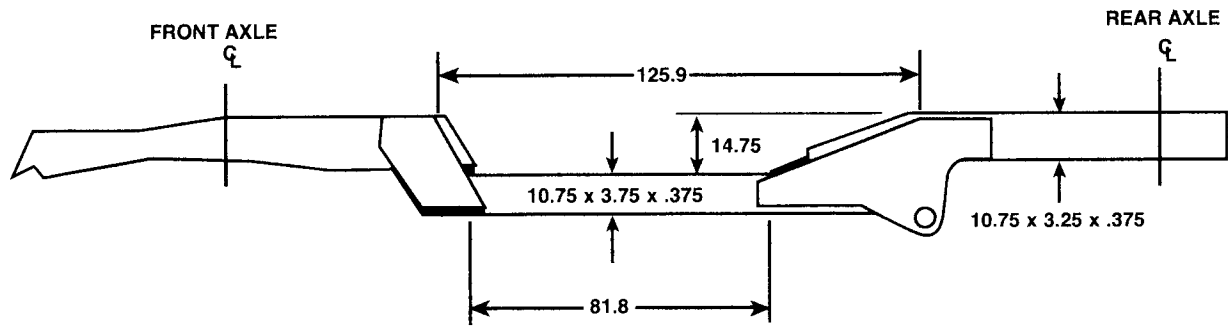

250	320	"Drop Frame"	61
173	286	152.3	104
186	286	165.3	91
197	286	176.3	80
210	286		67
246	322		67

MODEL	SPEEDS	RATIOS (LOW/HIGH)
<b>ALLISON</b>		
4500 RDS	5	4.70/0.76
4500 RDS	6	4.70/0.67

MODEL	HORSEPOWER
<b>CUMMINS</b>	
ISL G 320	320 HP [239 kW] @ 2000

**CAPACITY MAKE MODEL**

**FRONT AXLES**

20,000 lb.  
[9 072 kg] MACK FXL20

**REAR AXLES**

38,000 lb.  
[17 237 kg] MACK S38R

46,000 lb.  
[20 866kg] MACK S462  
MERITOR RT46-160

52,000 lb.  
[23 600kg] MACK S522







# Engine Performance Curve

Cummins Inc

Columbus, Indiana 47202-3005  
http://www.cummins.com

## ISL G 320

**320 BHP (239 kW) @ 2000 RPM**  
**1000 Lb-Ft. (1356 N-m) @ 1300 RPM**

Automotive  
Pg. No.

Curve Number: **FR93276**      CPL Code: **3297**      Date: **20-Mar-2009**

Compression Ratio: **12:1**  
Fuel System:  
Cylinders: **6**  
Bore: **4.49 in (114 mm)**  
Stroke: **5.69 in (145 mm)**

Engine Configuration: **D883002BX03**  
Emission Certification: **CARB 2010**  
Aspiration: **Turbocharged and Charge Air Cooled**  
Displacement: **543 in3 (8.9 L)**

### Automotive Applications

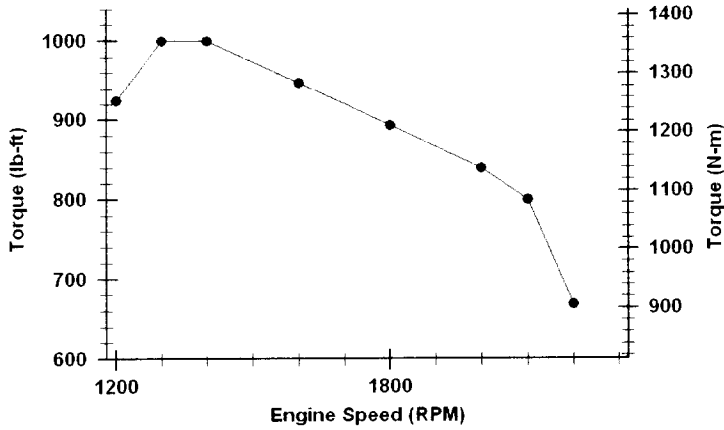

Torque Output		
RPM	lb-ft	N-m
1,200	925	1,254
1,300	1,000	1,356
1,400	1,000	1,356
1,600	947	1,284
1,800	893	1,211
2,000	840	1,139
2,100	800	1,085
2,200	668	906

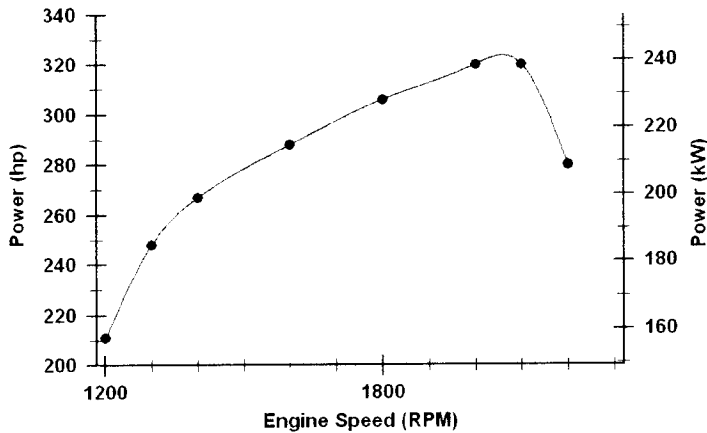

Power Output		
RPM	hp	kW
1,200	211	157
1,300	248	185
1,400	267	199
1,600	288	215
1,800	306	228
2,000	320	239
2,100	320	239
2,200	280	209

Curves shown above represent mature gross engine performance capabilities obtained and corrected in accordance with SAE J1995 conditions and 100 kPa (29.61 in Hg) barometric pressure [90 m (300ft) altitude], 25 deg C (77 deg F) inlet air temperature, and 1kPa (0.30 in Hg) water vapor pressure with Natural Gas meeting Cummins Engineering Standard 14608.

**Rick D Mason, Steven J Beem**  
Customer Engineering

Certified within 5%

Final-(Estimated data)

Bold entries revised after 1-Dec-2008

**Cummins Confidential**



# Engine Performance Curve

Cummins Inc

Columbus, Indiana 47202-3005  
http://www.cummins.com

## ISL G 320

**320 BHP (239 kW) @ 2000 RPM**  
**1000 Lb-Ft. (1356 N-m) @ 1300 RPM**

Automotive  
Pg. No.

Curve Number: **FR93276**      CPL Code: **3297**      Date: **20-Mar-2009**      **2**

Compression Ratio: **12:1**  
Fuel System:  
Cylinders: **6**  
Bore: **4.49 in (114 mm)**  
Stroke: **5.69 in (145 mm)**

Engine Configuration: **D883002BX03**  
Emission Certification: **CARB 2010**  
Aspiration: **Turbocharged and Charge Air Cooled**  
Displacement: **543 in3 (8.9 L)**

### General Performance Data

Maximum low idle speed: **900 RPM**  
Minimum low idle speed: **700 RPM**  
Nominal no load governed speed: **2,400 RPM**  
Maximum overspeed capability: **3,150 RPM**  
Torque available at clutch engagement: **550 lb-ft**      **746 N-m**

### Air Induction System

Maximum temperature rise between ambient air and engine air inlet: **20 delta deg F**      **11.1 delta deg C**

### Exhaust System

Maximum back pressure imposed by complete exhaust system: **67.9 in H2O**      **17 kPa**  
Minimum exhaust back pressure: **0 in H2O**      **0 mm H2O**

### Cooling System

Maximum coolant temperature - engine out: **212 deg F**      **100 deg C**  
Maximum coolant pressure (exclusive of pressure cap; closed thermostat at maximum no load speed): **41 psi**      **283 kPa**  
Minimum cooling capability @ nominal fuel rate [Level II] with 20 mile/hr (32 km/hr) ram air speed and 50/50 E.G. coolant:  
Engine out coolant to ambient @ 2,000 RPM: **106 delta deg F**      **58.9 delta deg C**  
Engine out coolant to ambient @ 1,300 RPM: **115 delta deg F**      **63.9 delta deg C**  
Charge air cooler to ambient @ 2,000 RPM: **38 delta deg F**      **21.1 delta deg C**  
Maximum allowable pressure drop across charge air cooler and OEM CAC piping (CACDP): **4 in-Hg**      **13.5 kPa**  
Maximum coolant temperature for engine protection controls: **220 deg F**      **104 deg C**

### Maximum Rating Performance Data

	Governed Speed		Maximum Power		Peak Torque	
	2,200 RPM	209 kW	2,000 RPM	239 kW	1,300 RPM	185 kW
Engine Speed	2,200 RPM	209 kW	2,000 RPM	239 kW	1,300 RPM	185 kW
Output Power	280 hp	209 kW	320 hp	239 kW	248 hp	185 kW
Torque	668 lb-ft	906 N-m	840 lb-ft	1,139 N-m	1,000 lb-ft	1,356 N-m
Inlet Air Flow	388 ft3/min	183 L/s	455 ft3/min	215 L/s	316 ft3/min	149 L/s
Charge Air Flow	28.3 lb/min	12.8 kg/min	32 lb/min	14 kg/min	22 lb/min	10 kg/min
Exhaust Gas Flow	1,158 ft3/min	547 L/s	1,314 ft3/min	620 L/s	956 ft3/min	451 L/s
Exhaust Gas Temperature	1,169 deg F	632 deg C	1,176 deg F	636 deg C	1,126 deg F	608 deg C
Heat Rejection to Coolant	10,160 BTU/min	179 kW	10,450 BTU/min	184 kW	6,800 BTU/min	120 kW
Radiator Coolant Flow *	97 gpm	6.1 L/s	88 gpm	5.6 L/s	57 gpm	3.6 L/s
Turbo Comp. Outlet Pressure	38 in-Hg	128 kPa	55 in-Hg	186 kPa	49 in-Hg	165 kPa
Turbo Comp. Outlet Temperature	280 deg F	138 deg C	357 deg F	181 deg C	355 deg F	179 deg C
Fuel Consumption	106 lb/hr	48.1 kg/hr	116 lb/hr	52.6 kg/hr	82 lb/hr	37.2 kg/hr
Brake Mean Effective Pressure	187 psi	1,289 kPa	235 psi	1,620 kPa	279 psi	1,924 kPa

\* - Radiator Coolant Flow is approximately 5% less with a continuously deaerating system.  
Coolant: 50/50 - Ethylene Glycol/Water by volume. Values are within +/- 5%.

### Change Log

Date	Author	Change Description
7/25/2008	Jim A Cole	CREATED RATING FROM FR92424 FOR 2008HH.

End of Report

Bold entries revised after 1-Dec-2008

**Cummins Confidential**

# CWI ISL G Protection Plan I

## Extended Coverage: CWI Protection Plan I

**New prices effective January 1, 2013-December 31, 2013**

Available on Cummins Westport ISL G engines in the United States and Canada.

Use Protection Plan I to ensure against major repair costs, no matter where your business takes you. Protection Plan I includes:

- Registered parts and labor:
- Covers Internal components and major engine systems:
- Covers all these components, including listed parts below and their mounting hardware and gaskets:
  - Cylinder head assembly
  - Rocker lever assembly
  - ECM
  - Piston, rings, and liners
  - Lube oil cooler assembly
  - Front gear cover
  - Oil pan
  - Connecting rod assembly
  - Lube Pump assembly
  - Camshaft and bushings
  - Cam follower assemblies
  - Crank shaft assemblies
  - EGR cooler, valve and mixer
  - Fuel Injectors (excluding aftertreatment injector)
  - Turbo
  - Water pump
  - Fuel pump
  - Air Compressor
  - Select engine sensors
  - Low fuel pressure regulator

**THIS WARRANTY IS EXPRESSLY IN LIEU OF ALL OTHER WARRANTIES AND REPRESENTATIONS OR CONDITIONS, STATUTORY OR OTHERWISE, EXPRESSED OR IMPLIED INCLUDING, BUT NOT LIMITED TO, IMPLIED WARRANTY OF MERCHANTABILITY OR FITNESS FOR A PARTICULAR PURPOSE.**

**THESE LIMITATIONS AND EXCLUSIONS ARE IMPORTANT  
AND MUST BE READ AND UNDERSTOOD.**

**LIMITATIONS** – Mack Trucks, Inc.'s obligation is limited to, at its sole option, repair or replacement of parts which are acknowledged by it to be defective. In the case of acknowledged defective assemblies, exchange with factory rebuilt units may occur. The defective parts or assemblies replaced shall become the property of Mack Trucks, Inc.. Warranty repairs performed by the dealer's shop in accordance with the terms of the warranty set forth herein are free of charge. Warranty repairs do not constitute an extension of the original warranty period for the vehicle or any part thereof. Warranty consideration can only be given if the deficiency is brought to the attention of an authorized Mack Truck dealer upon discovery and the vehicle must be made available, in a timely fashion during the coverage period, for repair.

**NO PAYMENT OR OTHER COMPENSATION WILL BE MADE FOR CONSEQUENTIAL,  
INDIRECT OR INCIDENTAL EXPENSES OR DAMAGES OF ANY KIND.**

**EXCLUSIONS:**

1. **REPAIR:** Warranty consideration can only be given if the deficiency is brought to the attention of an authorized Mack Truck dealer upon discovery and the truck must be made available, in a timely fashion during the warranty period, for repair. Failures resulting from the user's unreasonable delay in making the truck available, after being notified of a potential product problem, are not covered.
2. **REPEAT REPAIRS:** The term "repeat repair" only refers to the repair or replacement of the exact same part or component more than once. Repair or replacements of different components within the same system does not constitute a repeated repair.
3. **DAMAGES:** Damages due to accidents, misuse, negligence, improper operations, alterations, storage or transport, operation at excessive speeds, loading beyond the factory rated load capacity, and improper or insufficient maintenance services are not covered. Damages due to failure to follow Mack Trucks, Inc. service procedures are considered damages due to improper maintenance services.
4. **APPLICATION:** The responsibility of determining the correct application and/or specification for a vehicle sold to a customer belongs at the selling location. Vehicle application problems, including but not limited to, replacement of incorrect axle or transmission gear ratios, failures of component parts of vehicles being operated in excess of factory rated load capacities, or the use of a vehicle for a purpose of which it was not intended are not covered.
5. **ENVIRONMENTAL DAMAGE:** Parts made out of cloth, leather, wood, rubber, synthetics, paint or chrome which have been effected by exposure to the elements or chemical influence including, but not limited to road salts/chemicals, industrial fall-out or the use of improper cleaners, polishes, and/or waxes are not covered.
6. **GLASS:** Glass breakage and scratches are not covered unless positive physical proof of manufacturing responsibility is established.
7. **SUSPENSION PARTS:** Suspension parts, including but not limited to rubber bushings, torque rod bushings, spring pins and bushings, and all greased lubrication points that fail due to improper maintenance, abnormality severe service or abuse are not covered.
8. **ALTERATIONS:** Any vehicle repaired and/or altered in any way, so as to adversely effect, in Mack Trucks, Inc.'s sole judgment, its stability or reliability, is not covered.
9. **OPTIONAL EQUIPMENT:** Any part of the truck that fails, malfunctions or does not perform as a result of improper conversion or installation of special bodies or equipment by other manufacturers or suppliers is not covered.
10. **MAINTENANCE AND PARTS CONSUMED ("Consumables"):** Normal maintenance services including, but not limited to, replacement of oil filters, adjustments of the engine injection pump / transmission / brakes / linkages, as well as diagnosis, test time and all other adjustments, are not covered. Parts which are normally consumed or worn out during the vehicle's usual service life and customarily replaced during usual maintenance service are not covered or have limited coverage. These parts include, but are not limited to, the following:  
*NOT COVERED* - Brake linings, clutch brake, clutch linings, mud flaps and brackets.  
*COVERED FOR 30 DAYS* - Fluorescent lights or ballast, light bulbs, fuses, wiper blades and all filters (oil, fuel, air, etc.)  
*COVERED FOR 90 DAYS* - Loose fasteners, leaking fittings or hose clamps.  
*COVERED FOR 12 MONTHS, OR 100,000 MILES (161,000 KM) OR 3,250 OPERATING HOURS, WHICHEVER OCCURS FIRST* - Cab suspension on models used in heavy duty applications, battens, frame paint, sealed light assemblies, exhaust flex pipe, hose clamps, all rubber/nylon bushings or mounts, flexible hoses, all belts, shock absorbers (leakage only), wheel seats, and all grease lubricated points (tie rods ends, king-pins, u-joints, spring pins, etc.)
11. **ALIGNMENT:** Alignment of axle(s) and balancing of tires, including changing of axle camber, caster, toe and thrust angle settings are not covered.
12. **NON-GENUINE PARTS:** Any vehicle which has been repaired by use of parts and accessories, as well as major assemblies and exchange units, which are substandard and which cause a vehicle component or system to fail are not covered.
13. **TIRES:** Tires are covered by separate warranties given by their respective manufacturers.
14. **CAB STRUCTURE AND CORROSION:** Cab structural defects or cab corrosion that occurs in areas of the cab that have been previously damaged, repaired, altered or modified are not covered. Cab corrosion where metal is perforated from the outside to the inside is not covered.
15. **ENGINES AND AUTOMATIC TRANSMISSIONS:** The engines and Allison automatic transmissions used in Mack trucks are warranted by their respective manufacturers. Refer to the engine and transmission manufacturers' warranty statements.
16. **ODOMETER READING:** Any vehicle in which the odometer has been disconnected or the mileage reading has been altered and the actual mileage cannot be readily determined is not covered.
17. **ACCESS TO INFORMATION:** The user must allow Mack Trucks, Inc. full access to all data stored in all Electronic Control Modules; failure to do so may result in the loss of warranty coverage.
18. **PREMIUM LABOR:** Labor for overtime and/or shift differential is not covered.
19. **EXCESSIVE LABOR:** Excessive labor for a warrantable repair due to installation of equipment or body by the customer is not covered.
20. **MISC. EXPENSE:** Road service, towing, meals, lodging, telephone calls, travel time, loss of cargo, downtime, loss of revenue, rental vehicles, or driver's wages and other miscellaneous expenses are not covered. Shop supplies, lube oil, lubricants, sealers, anti-freeze, filter elements and labor performed by a non-approved location are not covered.
21. **ADDITIONAL COMPONENTS:** Components or parts that are not installed by Mack Trucks, Inc. are not covered. Mack Trucks, Inc. factory manufacturing records will determine Mack Trucks, Inc. installations.
22. **APPLICATION CHANGE OR CHANGE OF OWNERSHIP:** If at any time during the term of the original warranty there is a change in the application of the vehicle or a change in ownership, the owner must notify Mack Trucks, Inc., Post Office Box 26115, Greensboro, NC 27402-8115 in writing and within 30 days of date of the change. Failure to provide such timely notice may result in the warranty becoming null and void. If the change in ownership is accepted by Mack Trucks, Inc., and/or the change in application does not affect coverage, Mack Trucks, Inc. will transfer any remaining applicable portion of the warranty to the new owner or, for the new application.

Mack Trucks, Inc.  
Post Office Box 26115  
Greensboro, North Carolina 27402-8115

(December 2009)

# HEAVY DUTY WARRANTY CERTIFICATE



Mack Trucks, Inc. warrants certain individual components of the new Mack truck to be free from defects in material and workmanship under normal use and service up to the periods as specified provided all Mack Trucks, Inc. maintenance and inspection requirements found in the Operator's Manuals and service manual/instructions are followed. All warranty periods are calculated from date in service. All coverage is 100% for parts and labor except as noted.

**LIMITATIONS AND EXCLUSIONS TO THIS WARRANTY APPEAR ON THE REVERSE SIDE OF THIS CERTIFICATE. THESE LIMITATIONS AND EXCLUSIONS ARE IMPORTANT AND MUST BE READ AND UNDERSTOOD.**

This warranty applies to Model Year 2013 and newer models manufactured by Mack Trucks, Inc. with EPA '10 Engine Emissions operated in the United States and Canada. Specific coverage is based on the application and weight class as described in the following chart.

CHASSIS BUILT WITH EPA '10 EMISSION ENGINES VEHICLE APPLICATION: HEAVY DUTY	Hours	Months	Miles	Kilometers
<b>SCHEDULE 1. BASIC VEHICLE*</b> **Roadside Assistance and Towing on warrantable failures are covered for 3 Months/5,000 Miles/8,050 Kilometers *Brake Drums are covered for 12 months or 25,000 miles/40,000 kilometers only.	---	12	100,000	161,000
<b>SCHEDULE 2. MACK DIESEL ENGINE</b> Standard Warranty **Standard Warranty Includes: Roadside Assistance and Towing on warrantable engine failures	6,250	24	250,000	402,500
Major Components: Block, Stiffener (Ladder Frame); Camshaft Forging; Camshaft Caps & Bolts; Connecting Rod & Cap Forging; Coolant Pump Housing; Crankshaft Forging; Cylinder Block Casting; Cylinder Head Casting & Bolts; Engine Gears (Rear Mounted); Exhaust Manifold Casting; Flywheel Housing; Intake Manifold Casting; Main Bearing Bolts & Caps; Oil Pump: Drive & Driven Gears; Thermostat Housing; Timing Gear Cover & Mounting Plate	12,500	60	500,000	805,000
Coverage also applies to consumables such as lubricant, antifreeze, filter elements, belts, hoses and similar maintenance items not reusable and replaced directly as a result of a warrantable engine, carrier or transmission failure. Components not manufactured by Mack Trucks, Inc. but used on MACK diesel engine assemblies are excluded from the coverage in Schedule 2. These components are covered by the component manufacturer's warranty in effect at the time of delivery. Consult your local MACK service facility for details.				
<b>SCHEDULE 3. MACK TRANSMISSIONS</b>				
T300 and TM300 Transmissions Towing on warrantable failures for Mack T300 and TM300 Transmissions	---	36 24	400,000 250,000	644,000 402,500
Mack mDrive Transmissions m-Drive Clutch Towing on warrantable failures for Mack mDrive Transmissions	6,250 6,250 ---	36 36 24	250,000 250,000 250,000	402,500 402,500 402,500
<b>SCHEDULE 4. DPF SYSTEM COMPONENTS (OEM WARRANTY) DPF/SCR SYSTEM COMPONENTS (EMISSION WARRANTY)</b> *Roadside Assistance and Towing on warrantable DPF/SCR failures	6,250 3,250 6,250	24 12 24	250,000 100,000 250,000	402,500 161,000 402,500
<b>SCHEDULE 5. MACK CARRIER / AXLE HOUSING / FRONT AXLE</b>				
Rear Carriers and Housing Front I-Beam, Steering Knuckle, Tie Rod Rear Carrier Seals, Gaskets SBE Bogie and Carrier: Regardless of Carrier Model	---	36 36 12 12	300,000 300,000 100,000 100,000	483,000 483,000 161,000 161,000
<b>SCHEDULE 6. TRUNNION BRACKET &amp; SPINDLE, SUSPENSION TRUNNION (except bushings)</b>	---	36	300,000	483,000
<b>SCHEDULE 7. FRAMES: SIDE RAILS AND CROSSMEMBERS</b> Extended Warranty for GU Model Chassis	---	36 60	300,000 500,000	483,000 805,000
<b>SCHEDULE 8. CAB STRUCTURE</b>	---	24	200,000	322,000
<b>SCHEDULE 9. CAB CORROSION</b> Coverage applies to perforation (an actual hole in the cab panel) due to corrosion. Coverage does not apply to corrosion caused by damage to paint finish.	---	60	500,000	805,000
<b>SCHEDULE 10. Components not manufactured by Mack Trucks, Inc. may have warranty coverage different from the above as they are covered by the manufacturer's warranty. Consult your local MACK dealership for details.</b>				

\*\*Roadside Assistance and Towing coverage does not apply to vendor engines, transmissions and axles.

*Allison Transmission Coverage  
For 5yrs quoted in Bid*

**SUPPLY BOND**

**Travelers Casualty and Surety Company of America  
Hartford, CT 06183**

Bond No.: 105749977

KNOW ALL MEN BY THESE PRESENTS: That Worldwide Equipment Inc, called the Principal, and Travelers Casualty and Surety Company of America, a Connecticut corporation, with its home office located in Connecticut, called the Surety, are held and firmly bound unto Lexington-Fayette Urban County Government, called the Obligee, in the amount of Two hundred fifty thousand and 00/100 ----- Dollars (250,000.00), for the payment whereof Principal and Surety bind themselves, their heirs, executors, administrators, successors and assigns, jointly and severally, as provided herein.

WHEREAS, Principal entered into that certain material contract with the Obligee dated May 17, 2013 for Six (6) 2014 Mack LEU 613 CNG Trucks, a copy of which is by referenced made a part hereof ("Material Contract").

NOW, THEREFORE, if Principal shall faithfully comply with all terms and conditions of said Material Contract, or if the Principal shall pay, indemnify, and hold harmless the Obligee from all direct damages sustained by the Obligee as a result of any default by the Principal under the Material Contract, then this obligation shall be void; otherwise to remain in full force and effect.

PROVIDED, however, that it is a condition precedent to recovery under this bond that written notice of any default claimed under the Material Contract be provided to Surety at the following address: Travelers Bond, One Tower Square, Hartford CT 06183 within 60 days from the date of default; and

PROVIDED, further, that any suit by the Obligee under this bond must be instituted before the earlier of: (a) the expiration of one year from the date the Principal was obligated under the Material Contract to deliver the materials to the Obligee, or (b) the expiration of one year from the date any other default by the Principal under the Material Contract. If the limitation set forth in this bond is void, prohibited by law or unenforceable for any reason, the minimum period of limitation available to sureties as a defense in the jurisdiction of the suit shall be applicable, and said period of limitation shall be deemed to have accrued and shall commence to run no later than the earlier of (y) the date the Principal was obligated under the Material Contract to deliver the materials to the Obligee or (z) the date of any other default by the Principal under the Material Contract; and

PROVIDED, further that no right of action shall accrue on this bond to or for the use of any person or corporation other than the Obligee named herein or its successor.

Signed this 21st day of May, 2013.

**Worldwide Equipment Inc.**  
(Principal)

By: Timothy D. Brown V.P.

**Travelers Casualty and Surety Company of America**  
By: Harry P. Bielecki  
Harry P. Bielecki, Attorney-in-Fact



POWER OF ATTORNEY

Farmington Casualty Company
Fidelity and Guaranty Insurance Company
Fidelity and Guaranty Insurance Underwriters, Inc.
St. Paul Fire and Marine Insurance Company
St. Paul Guardian Insurance Company

St. Paul Mercury Insurance Company
Travelers Casualty and Surety Company
Travelers Casualty and Surety Company of America
United States Fidelity and Guaranty Company

Attorney-In Fact No. 220783

Certificate No. 005213958

KNOW ALL MEN BY THESE PRESENTS: That Farmington Casualty Company, St. Paul Fire and Marine Insurance Company, St. Paul Guardian Insurance Company, St. Paul Mercury Insurance Company, Travelers Casualty and Surety Company, Travelers Casualty and Surety Company of America, and United States Fidelity and Guaranty Company are corporations duly organized under the laws of the State of Connecticut, that Fidelity and Guaranty Insurance Company is a corporation duly organized under the laws of the State of Iowa, and that Fidelity and Guaranty Insurance Underwriters, Inc., is a corporation duly organized under the laws of the State of Wisconsin (therein collectively called the "Companies"), and that the Companies do hereby make, constitute and appoint

James J. Dooley Jr., James J. Dooley III, Peter J. Emigh, Harry P. Bielecki, and Megan B. Dooley

of the City of Allentown, State of Pennsylvania, their true and lawful Attorney(s)-in-Fact, each in their separate capacity if more than one is named above, to sign, execute, seal and acknowledge any and all bonds, recognizances, conditional undertakings and other writings obligatory in the nature thereof on behalf of the Companies in their business of guaranteeing the fidelity of persons, guaranteeing the performance of contracts and executing or guaranteeing bonds and undertakings required or permitted in any actions or proceedings allowed by law.

IN WITNESS WHEREOF, the Companies have caused this instrument to be signed and their corporate seals to be hereto affixed, this 2nd day of October, 2012.

Farmington Casualty Company
Fidelity and Guaranty Insurance Company
Fidelity and Guaranty Insurance Underwriters, Inc.
St. Paul Fire and Marine Insurance Company
St. Paul Guardian Insurance Company

St. Paul Mercury Insurance Company
Travelers Casualty and Surety Company
Travelers Casualty and Surety Company of America
United States Fidelity and Guaranty Company



State of Connecticut
City of Hartford ss.

By: [Signature]
Robert L. Raney, Senior Vice President

On this the 2nd day of October, 2012, before me personally appeared Robert L. Raney, who acknowledged himself to be the Senior Vice President of Farmington Casualty Company, Fidelity and Guaranty Insurance Company, Fidelity and Guaranty Insurance Underwriters, Inc., St. Paul Fire and Marine Insurance Company, St. Paul Guardian Insurance Company, St. Paul Mercury Insurance Company, Travelers Casualty and Surety Company, Travelers Casualty and Surety Company of America, and United States Fidelity and Guaranty Company, and that he, as such, being authorized so to do, executed the foregoing instrument for the purposes therein contained by signing on behalf of the corporations by himself as a duly authorized officer.

In Witness Whereof, I hereunto set my hand and official seal.
My Commission expires the 30th day of June, 2016.



[Signature]
Marie C. Tetreault, Notary Public

This Power of Attorney is granted under and by the authority of the following resolutions adopted by the Boards of Directors of Farmington Casualty Company, Fidelity and Guaranty Insurance Company, Fidelity and Guaranty Insurance Underwriters, Inc., St. Paul Fire and Marine Insurance Company, St. Paul Guardian Insurance Company, St. Paul Mercury Insurance Company, Travelers Casualty and Surety Company, Travelers Casualty and Surety Company of America, and United States Fidelity and Guaranty Company, which resolutions are now in full force and effect, reading as follows:

**RESOLVED**, that the Chairman, the President, any Vice Chairman, any Executive Vice President, any Senior Vice President, any Vice President, any Second Vice President, the Treasurer, any Assistant Treasurer, the Corporate Secretary or any Assistant Secretary may appoint Attorneys-in-Fact and Agents to act for and on behalf of the Company and may give such appointee such authority as his or her certificate of authority may prescribe to sign with the Company's name and seal with the Company's seal bonds, recognizances, contracts of indemnity, and other writings obligatory in the nature of a bond, recognizance, or conditional undertaking, and any of said officers or the Board of Directors at any time may remove any such appointee and revoke the power given him or her; and it is

**FURTHER RESOLVED**, that the Chairman, the President, any Vice Chairman, any Executive Vice President, any Senior Vice President or any Vice President may delegate all or any part of the foregoing authority to one or more officers or employees of this Company, provided that each such delegation is in writing and a copy thereof is filed in the office of the Secretary; and it is

**FURTHER RESOLVED**, that any bond, recognizance, contract of indemnity, or writing obligatory in the nature of a bond, recognizance, or conditional undertaking shall be valid and binding upon the Company when (a) signed by the President, any Vice Chairman, any Executive Vice President, any Senior Vice President or any Vice President, any Second Vice President, the Treasurer, any Assistant Treasurer, the Corporate Secretary or any Assistant Secretary and duly attested and sealed with the Company's seal by a Secretary or Assistant Secretary; or (b) duly executed (under seal, if required) by one or more Attorneys-in-Fact and Agents pursuant to the power prescribed in his or her certificate or their certificates of authority or by one or more Company officers pursuant to a written delegation of authority; and it is

**FURTHER RESOLVED**, that the signature of each of the following officers: President, any Executive Vice President, any Senior Vice President, any Vice President, any Assistant Vice President, any Secretary, any Assistant Secretary, and the seal of the Company may be affixed by facsimile to any Power of Attorney or to any certificate relating thereto appointing Resident Vice Presidents, Resident Assistant Secretaries or Attorneys-in-Fact for purposes only of executing and attesting bonds and undertakings and other writings obligatory in the nature thereof, and any such Power of Attorney or certificate bearing such facsimile signature or facsimile seal shall be valid and binding upon the Company and any such power so executed and certified by such facsimile signature and facsimile seal shall be valid and binding on the Company in the future with respect to any bond or understanding to which it is attached.

I, Kevin E. Hughes, the undersigned, Assistant Secretary, of Farmington Casualty Company, Fidelity and Guaranty Insurance Company, Fidelity and Guaranty Insurance Underwriters, Inc., St. Paul Fire and Marine Insurance Company, St. Paul Guardian Insurance Company, St. Paul Mercury Insurance Company, Travelers Casualty and Surety Company, Travelers Casualty and Surety Company of America, and United States Fidelity and Guaranty Company do hereby certify that the above and foregoing is a true and correct copy of the Power of Attorney executed by said Companies, which is in full force and effect and has not been revoked.

IN TESTIMONY WHEREOF, I have hereunto set my hand and affixed the seals of said Companies this 1st day of May, 2013

*Kevin E. Hughes*  
Kevin E. Hughes, Assistant Secretary



To verify the authenticity of this Power of Attorney, call 1-800-421-3880 or contact us at [www.travelersbond.com](http://www.travelersbond.com). Please refer to the Attorney-In-Fact number, the above-named individuals and the details of the bond to which the power is attached.