



LEXINGTON

Bid 11-2024 Addendum 2

Gudenkauf LLC.

Gudenkauf LLC.

Supplier Response

Event Information

Number: Bid 11-2024 Addendum 2
Title: Fiber Optic Cable Install and Repair
Type: Competitive Bid
Issue Date: 1/18/2024
Deadline: 2/8/2024 02:00 PM (ET)
Notes: ONLY ONLINE BIDS WILL BE ACCEPTED FOR THIS SOLICITATION. PRICING SHOULD BE SUBMITTED ON THE LINE ITEMS TAB ONLY. PRICING WITHIN SUBMITTALS WILL NOT BE ACCEPTED AND MAY MAKE YOUR BID NON-RESPONSIVE.

PLEASE UPLOAD ATTACHMENTS AS ONE FILE.

Contact Information

Contact: Jessica Allinder
Address: Procurement
Government Center Building
200 East Main Street
Lexington 40507
Email: jallinder@lexingtonky.gov

Gudenkauf LLC. Information

Contact: Sean Leist
Address: 2679 Mckinley Avenue
Columbus, OH 43204
Phone: (614) 679-6747
Email: sleist@gudenkauf.com

ONLY ONLINE BIDS WILL BE ACCEPTED! By submitting your response, you certify that you are authorized to represent and bind your company and that you agree to all bid terms and conditions as stated in the attached bid/RFP/RFQ/Quote/Auction documents.

Sean Leist
Signature

sleist@gudenkauf.com
Email

Submitted at 2/8/2024 07:10:03 AM (ET)

Response Attachments

Bid Response Form Gudenkauf.pdf

Bid Package Response Gudenkauf LLC.

Addendum 1 (1).pdf

Addendum 1

Addendum 2 (1).pdf

Addendum 2

Bid Attributes

1 Bid package

Have you completed and attached your bid package? This is a contractual agreement and required for all bids.

YES

Bid Lines

1 Wood Pole, 35-foot, Class 4

Quantity: 4 UOM: Each Unit Price: Total:

2 Wood Pole, 45-foot, Class 4

Quantity: 4 UOM: Each Unit Price: Total:

3 Down Guy (Standard)

Quantity: 6 UOM: Each Unit Price: Total:

4 Down Guy (Sidewalk)

Quantity: 3 UOM: Each Unit Price: Total:

5 Span Wire (Messenger Cable)

Quantity: 12500 UOM: Linear Feet Price: Total:

6	Conduit, Above Ground, Rigid Steel, 2-inch	Quantity: <u>400</u> UOM: <u>Linear Feet</u>	Price: <input type="text" value="\$11.50"/>	Total: <input type="text" value="\$4,600.00"/>
7	Conduit, Underground, Non-Traffic Bearing Surface, 2-inch	Quantity: <u>12000</u> UOM: <u>Linear Feet</u>	Price: <input type="text" value="\$11.50"/>	Total: <input type="text" value="\$138,000.00"/>
8	Conduit, Under Roadway or Commercial Driveway, 2-inch	Quantity: <u>400</u> UOM: <u>Linear Feet</u>	Price: <input type="text" value="\$17.75"/>	Total: <input type="text" value="\$7,100.00"/>
9	Traffic Bearing Junction Box w/Lid	Quantity: <u>20</u> UOM: <u>Each</u>	Unit Price: <input type="text" value="\$2,805.00"/>	Total: <input type="text" value="\$56,100.00"/>
10	Install Fiber-Optic Cable	Quantity: <u>13000</u> UOM: <u>Linear Feet</u>	Price: <input type="text" value="\$1.30"/>	Total: <input type="text" value="\$16,900.00"/>
11	Fiber Optic Cable	Quantity: <u>13000</u> UOM: <u>Linear Feet</u>	Price: <input type="text" value="\$0.98"/>	Total: <input type="text" value="\$12,740.00"/>
12	Fusion splicing of fiber-optic cable (aerial or underground installation), (per 12 splices)	Quantity: <u>6</u> UOM: <u>Each</u>	Unit Price: <input type="text" value="\$425.00"/>	Total: <input type="text" value="\$2,550.00"/>
13	Pole Attachment	Quantity: <u>20</u> UOM: <u>Each</u>	Unit Price: <input type="text" value="\$96.00"/>	Total: <input type="text" value="\$1,920.00"/>
14	Drop to Cabinet (Pathway)	Quantity: <u>16</u> UOM: <u>Each</u>	Unit Price: <input type="text" value="\$388.00"/>	Total: <input type="text" value="\$6,208.00"/>
15	Demolish Existing Cable (per 500 feet)	Quantity: <u>4</u> UOM: <u>Each</u>	Unit Price: <input type="text" value="\$1,000.00"/>	Total: <input type="text" value="\$4,000.00"/>
16	Rock Removal (trench)	Quantity: <u>10</u> UOM: <u>Cubic Yard</u>	Price: <input type="text" value="\$55.00"/>	Total: <input type="text" value="\$550.00"/>
17	Solid Rock Bore	Quantity: <u>40</u> UOM: <u>Linear Feet</u>	Price: <input type="text" value="\$100.00"/>	Total: <input type="text" value="\$4,000.00"/>
18	One Extra Conduit Underground/Under Roadway	Quantity: <u>8000</u> UOM: <u>Linear Feet</u>	Price: <input type="text" value="\$7.75"/>	Total: <input type="text" value="\$62,000.00"/>
19	Two Extra Conduits Underground/Under Roadway	Quantity: <u>2000</u> UOM: <u>Linear Feet</u>	Price: <input type="text" value="\$13.50"/>	Total: <input type="text" value="\$27,000.00"/>
20	Pole Transfer – Steel Pole	Quantity: <u>10</u> UOM: <u>Each</u>	Unit Price: <input type="text" value="\$130.00"/>	Total: <input type="text" value="\$1,300.00"/>

2 1	Pole Transfer - Wooden Pole	Quantity: <u>10</u> UOM: <u>Each</u>	Unit Price: <input type="text" value="\$90.00"/>	Total: <input type="text" value="\$900.00"/>
2 2	Install Traffic Observation Camera	Quantity: <u>15</u> UOM: <u>Each</u>	Unit Price: <input type="text" value="\$255.00"/>	Total: <input type="text" value="\$3,825.00"/>
2 3	Install Wireless Units	Quantity: <u>10</u> UOM: <u>Each</u>	Unit Price: <input type="text" value="\$255.00"/>	Total: <input type="text" value="\$2,550.00"/>

Response Total: \$385,523.00



ADDENDUM #2

Bid Number: #11-2024

Date: February 1, 2024

Subject: Fiber Optic Cable Installation & Repair

Address Inquiries to:
Jessica Allinder
jallinder@lexingtonky.gov

TO ALL PROSPECTIVE SUBMITTERS:

Please be advised of the following clarifications to the above referenced bid:

1. Adding risk management provisions.
2. The bid opening has been moved to February 8, 2024.

Todd Slatin, Director
Division of Procurement

All other terms and conditions of the bid and specifications are unchanged. This letter should be signed, attached to and become a part of your submittal.

COMPANY NAME: Gudenkauf LLC.

ADDRESS: 2679 Mckinley Ave. Columbus OH 43204

SIGNATURE OF BIDDER: Sean Leist



**RISK MANAGEMENT PROVISIONS
INSURANCE AND INDEMNIFICATION**

INDEMNIFICATION AND HOLD HARMLESS PROVISION

- (1) It is understood and agreed by the parties that Contractor hereby assumes the entire responsibility and liability for any and all damages to persons or property caused by or resulting from or arising out of any act or omission on the part of Contractor or its employees, agents, servants, owners, principals, licensees, assigns or subcontractors of any tier (hereinafter "CONTRACTOR") under or in connection with this agreement and/or the provision of goods or services and the performance or failure to perform any work required thereby.
- (2) CONTRACTOR shall indemnify, save, hold harmless and defend the Lexington-Fayette Urban County Government and its elected and appointed officials, employees, agents, volunteers, and successors in interest (hereinafter "LFUCG") from and against all liability, damages, and losses, including but not limited to, demands, claims, obligations, causes of action, judgments, penalties, fines, liens, costs, expenses, interest, defense costs and reasonable attorney's fees that are in any way incidental to or connected with, or that arise or are alleged to have arisen, directly or indirectly, from or by CONTRACTOR's performance or breach of the agreement and/or the provision of goods or services provided that: (a) it is attributable to personal injury, bodily injury, sickness, or death, or to injury to or destruction of property (including the loss of use resulting therefrom), or to or from the negligent acts, errors or omissions or willful misconduct of the CONTRACTOR; and (b) not caused solely by the active negligence or willful misconduct of LFUCG.
- (3) In the event LFUCG is alleged to be liable based upon the above, CONTRACTOR shall defend such allegations and shall bear all costs, fees and expenses of such defense, including but not limited to, all reasonable attorneys' fees and expenses, court costs, and expert witness fees and expenses, using attorneys approved in writing by LFUCG, which approval shall not be unreasonably withheld.
- (4) These provisions shall in no way be limited by any financial responsibility or insurance requirements, and shall survive the termination of this agreement.
- (5) LFUCG is a political subdivision of the Commonwealth of Kentucky. CONTRACTOR acknowledges and agrees that LFUCG is unable to provide indemnity or otherwise save, hold harmless, or defend the CONTRACTOR in any manner.

FINANCIAL RESPONSIBILITY

BIDDER/CONTRACTOR understands and agrees that it shall, prior to final acceptance of its bid and the commencement of any work, demonstrate the ability to assure compliance with the above Indemnity provisions and these other risk management provisions.

INSURANCE REQUIREMENTS

YOUR ATTENTION IS DIRECTED TO THE INSURANCE REQUIREMENTS BELOW, AND YOU MAY NEED TO CONFER WITH YOUR INSURANCE AGENTS, BROKERS, OR CARRIERS TO DETERMINE IN ADVANCE OF SUBMISSION OF A RESPONSE THE AVAILABILITY OF THE INSURANCE COVERAGES AND ENDORSEMENTS REQUIRED HEREIN. IF YOU FAIL TO COMPLY WITH THE INSURANCE REQUIREMENTS BELOW, YOU MAY BE DISQUALIFIED FROM AWARD OF THE CONTRACT.

Required Insurance Coverage

BIDDER/CONTRACTOR shall procure and maintain for the duration of this contract the following or equivalent insurance policies at no less than the limits shown below and cause its subcontractors to maintain similar insurance with limits acceptable to LFUCG in order to protect LFUCG against claims for injuries to persons or damages to property which may arise from or in connection with the performance of the work hereunder by CONTRACTOR. The cost of such insurance shall be included in any bid:

<u>Coverage</u>	<u>Limits</u>
General Liability (Insurance Services Office Form CG 00 01)	\$1 million per occurrence, \$2 million aggregate or \$2 million combined single limit
Commercial Automobile Liability (Insurance Services Office Form CA 0001)	combined single, \$1 million per occurrence
Worker's Compensation	Statutory
Employer's Liability	\$500,000.00

The policies above shall contain the following conditions:

- a. All Certificates of Insurance forms used by the insurance carrier shall be properly filed and approved by the Department of Insurance for the Commonwealth of Kentucky (DOI). LFUCG shall be named as an additional insured in the General Liability Policy and Commercial Automobile Liability Policy using the Kentucky DOI approved forms.
- b. The General Liability Policy shall be primary to any insurance or self-insurance retained by LFUCG.
- c. The General Liability Policy shall include a Products and Completed Operations endorsement or Premises and Operations Liability endorsement unless deemed not to apply by LFUCG.
- d. The General Liability Policy shall include an Explosion-Collapse Underground (XCU) endorsement.
- e. LFUCG shall be provided at least 30 days advance written notice via certified mail, return receipt requested, in the event any of the required policies are canceled or non-renewed.
- f. Said coverage shall be written by insurers acceptable to LFUCG and shall be in a form acceptable to LFUCG. Insurance placed with insurers with a rating classification of no less than Excellent (A or A-) and a financial size category of no less than VIII, as defined by the most current Best's Key Rating Guide shall be deemed automatically acceptable.

Renewals

After insurance has been approved by LFUCG, evidence of renewal of an expiring policy must be submitted to LFUCG, and may be submitted on a manually signed renewal endorsement form. If the policy or carrier has changed, however, new evidence of coverage must be submitted in accordance with these Insurance Requirements.

Deductibles and Self-Insured Programs

IF YOU INTEND TO SUBMIT A SELF-INSURANCE PLAN IT MUST BE FORWARDED TO LEXINGTON-FAYETTE URBAN COUNTY GOVERNMENT, DIVISION OF RISK MANAGEMENT, 200 EAST MAIN STREET, LEXINGTON, KENTUCKY 40507 NO LATER THAN A MINIMUM OF FIVE (5) WORKING DAYS PRIOR TO THE RESPONSE DATE. Self-insurance programs, deductibles, and self-insured retentions in insurance policies are subject to separate approval by Lexington-Fayette Urban County Government's Division of Risk Management, upon review of evidence of BIDDER/CONTRACTOR's financial capacity to respond to claims. Any such programs or retentions must provide LFUCG with at least the same protection from liability and defense of suits as would be afforded by first-dollar insurance coverage. If BIDDER/CONTRACTOR satisfies any portion of the insurance requirements through deductibles, self-insurance programs, or self-insured retentions, BIDDER/CONTRACTOR agrees to provide Lexington-Fayette Urban County Government, Division of Risk Management, the following data prior to the final acceptance of bid and the commencement of any work:

- a. Latest audited financial statement, including auditor's notes.
- b. Any records of any self-insured trust fund plan or policy and related accounting statements.
- c. Actuarial funding reports or retained losses.
- d. Risk Management Manual or a description of the self-insurance and risk management program.
- e. A claim loss run summary for the previous five (5) years.
- f. Self-Insured Associations will be considered.

Safety and Loss Control

CONTRACTOR shall comply with all applicable federal, state, and local safety standards related to the performance of its works or services under this Agreement and take necessary action to protect the life, health and safety and property of all of its personnel on the job site, the public, and LFUCG.

Verification of Coverage

BIDDER/CONTRACTOR agrees to furnish LFUCG with all applicable Certificates of Insurance signed by a person authorized by the insurer to bind coverage on its behalf prior to final award, and if requested, shall provide LFUCG copies of all insurance policies, including all endorsements.

Right to Review, Audit and Inspect

CONTRACTOR understands and agrees that LFUCG may review, audit and inspect any and all of its records and operations to insure compliance with these Insurance Requirements.

DEFAULT

BIDDER/CONTRACTOR understands and agrees that the failure to comply with any of these insurance, safety, or loss control provisions shall constitute default and that LFUCG may elect at its option any single remedy or penalty or any combination of remedies and penalties, as available, including but not limited to purchasing insurance and charging BIDDER/CONTRACTOR for any such insurance premiums purchased, or suspending or terminating the work.

00470806



ADDENDUM #1

Bid Number: #11-2024

Date: January 19, 2024

Subject: Fiber Optic Cable Installation & Repair

Address Inquiries to:
Jessica Allinder
jallinder@lexingtonky.gov

TO ALL PROSPECTIVE SUBMITTERS:

Please be advised of the following clarifications to the above referenced bid:

1. See attached drawings.

Todd Slatin, Director
Division of Procurement

All other terms and conditions of the bid and specifications are unchanged. This letter should be signed, attached to and become a part of your submittal.

COMPANY NAME: Gudenkauf LLC.

ADDRESS: 2679 Mckinley Avenue, Columbus OH 43204

SIGNATURE OF BIDDER: Sean Leist



PREPARED BY _____ DATE _____
 CHECKED BY _____ DATE _____
 APPROVED BY _____ DATE _____

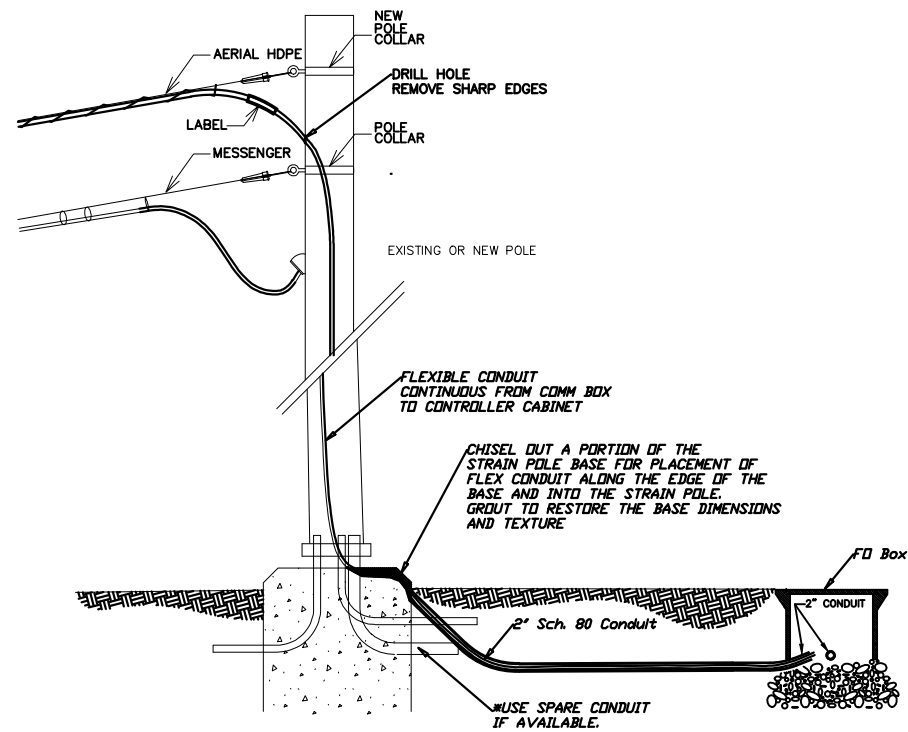

FIBER TO EXISTING STRAIN POLE

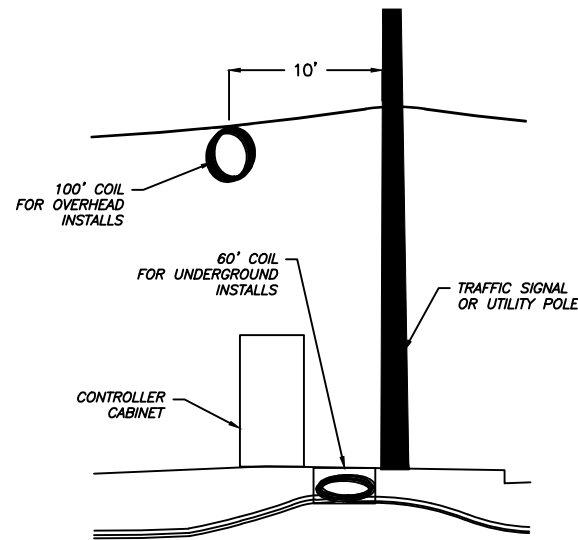
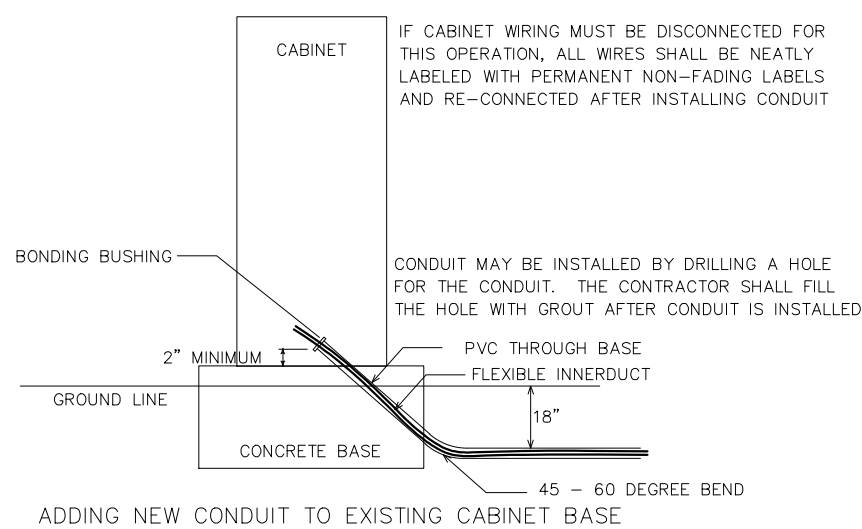

TYPICAL SLACK LOOP ARRANGMENT AT EACH TRAFFIC SIGNAL

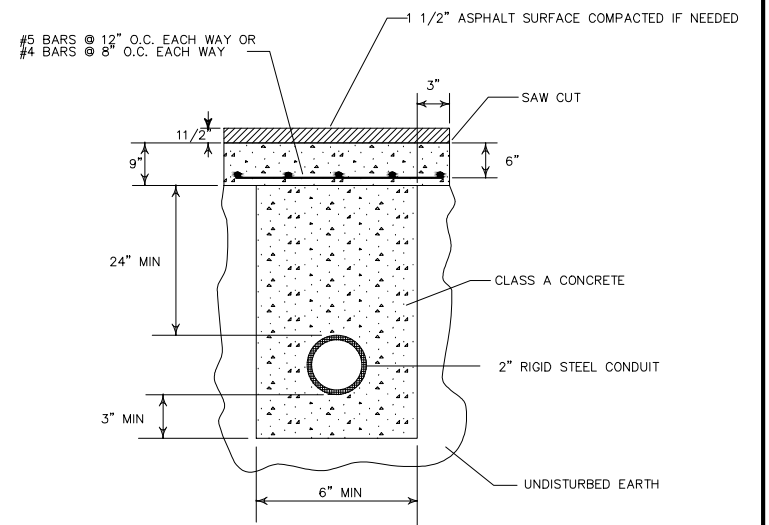

METHOD FOR REPAIRING OPEN CUT PAVEMENT

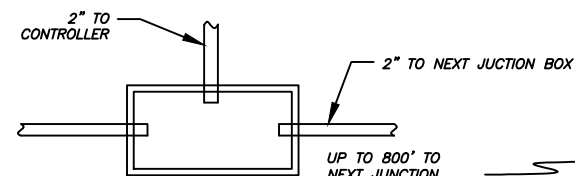

STANDARD INSTALLATION - PLAN VIEW

CONDUIT SPECIFICATIONS
 CONDUIT SHALL BE SMOOTHWALL or RIBBED, HIGH DENSITY POLYETHYLENE (HDPE), SCHEDULE 80, ORANGE.

STANDARD, POLY. PULL STRING SHALL BE PLACED INSIDE THE CONDUIT AS PART OF THE CONDUIT INSTALLATION.

Detectable Fiber-Optic Cable Pulling Tape shall be installed along with fiber optic cable when it is pulled. Pulling tape shall be Tensile Strength of 1,800-pounds, Width of 5/8-inch, Woven Construction, Pre-Lubricated, with Foot-Markings. Detectable Fiber-Optic Cable Pulling Tape shall be MGT Diversified Solutions, LLC part #P1800T (or approved equal)

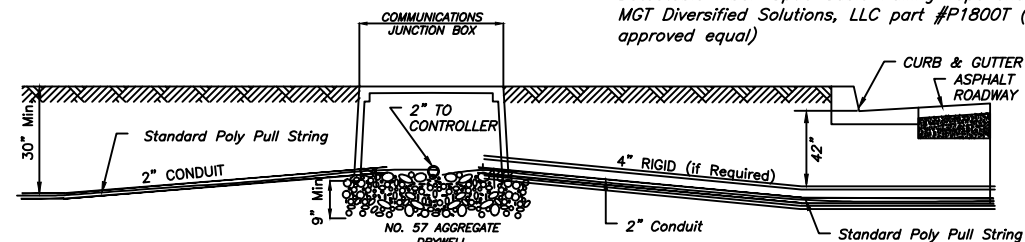

COMMUNICATIONS CONDUIT - STANDARD INSTALLATION - PROFILE

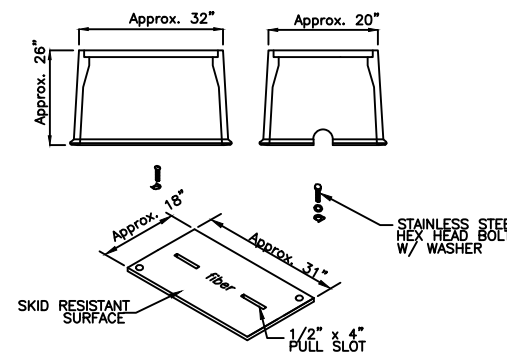

COMMUNICATIONS JUNCTION BOX SPECIFICATIONS
 TIER 22 - 17"x30" PD STYLE ASSEMBLY
 OPEN BOTTOM w/MOUSEHOLES
 *QUAZITE PD 1730-BB26 BOX & PG 1730-HH00 LID (or approved equal).

COMMUNICATIONS JUNCTION BOX - TRAFFIC BEARING, FIBER-OPTIC

NOT TO SCALE

PATHWAY DETAILS

USER: \$\$\$USER\$\$\$
 DATE: \$\$\$DATE\$\$\$
 FILE NAME: \$\$\$design\$file\$specification\$\$\$
 E-SHEET NAME:

PREPARED BY _____ DATE _____
 CHECKED BY _____ DATE _____
 APPROVED BY _____ DATE _____

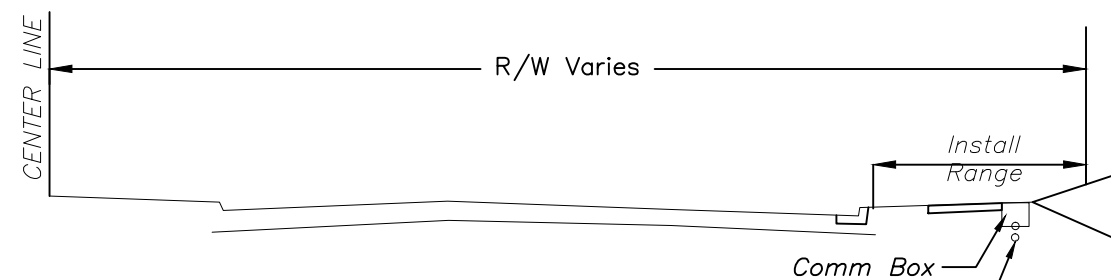

TYPICAL CROSS SECTION - CURB, GUTTER & SIDEWALK

SHOWS PREFERRED CONDUIT/COMM BOX LOCATION RELATIVE TO ROADWAY.

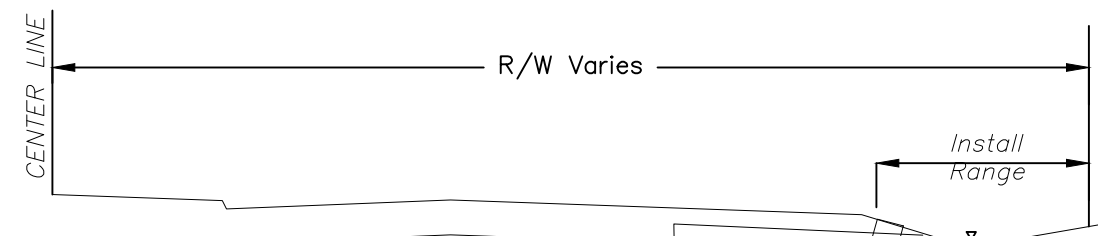

TYPICAL CROSS SECTION - SHOULDER

SHOWS PREFERRED CONDUIT/COMM BOX LOCATION RELATIVE TO ROADWAY.

Comm Box
 2" Conduit away from Comm Box
 No Comm Box Installation in Ditch Line.

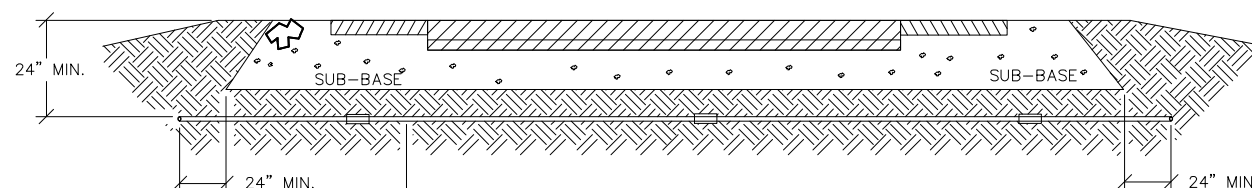

2" CONDUIT MINIMUM OR AS REQUIRED BY CODE. UNLESS 'OPEN CUT ROADWAY' IS INCLUDED AS A BID ITEM, CONDUIT MUST BE INSTALLED WITHOUT DISTURBING PAVEMENT. CONDUIT SHALL EXTEND A MINIMUM OF 24" PAST THE EDGE OF SUB-BASE UNLESS OTHERWISE DIRECTED BY THE ENGINEER.

CONDUIT INSTALLATION UNDER EXISTING PAVEMENT DETAIL

*SEE COMMUNICATIONS CONDUIT - STANDARD INSTALLATION - PROFILE FOR PROJECT DEPTHS

CONTRACTOR SHALL INSTALL UNDERGROUND UTILITY WARNING TAPE ABOVE CONDUIT AND/OR DUCTED CABLE AS SHOWN. THE TAPE SHALL BE 6" WIDE BY 7.0 MILS (NOMINAL) THICK, HAVE A MINIMUM TENSILE STRENGTH OF 600 POUNDS PER 6" WIDTH, AND BE COLOR CODE IMPREGNATED WITH ALKALI AND ACID STABLE, LEAD-FREE, ORGANIC PIGMENTS SUITABLE FOR DIRECT BURIAL. THE TAPE SHALL ALSO BE ULTRAVIOLET COLORFAST AND NON-DISTORTING WITH NO ELONGATION. THE TAPE SHALL INCLUDE BLACK LETTERING/SYMBOLS ON A RED BACKGROUND THAT CONFORMS TO THE APWA-ULCC NATIONAL COLOR CODE. THE TAPE SHALL CONTINUOUSLY READ, "CAUTION: ELECTRIC LINE BURIED BELOW" ALTERNATING WITH A 'NO DIGGING' SYMBOL.

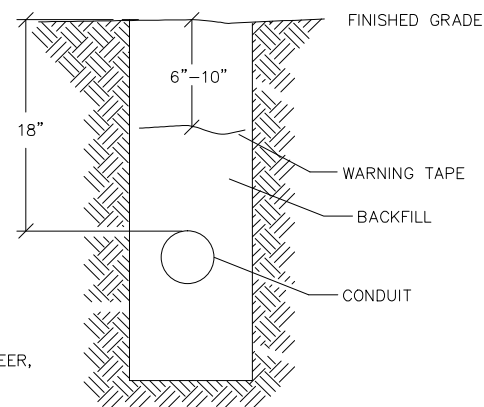

DEPTHS SHOWN FOR CONDUIT AND DUCTED CABLE ARE MINIMUMS. CONTRACTOR SHALL PLACE AND COMPACT BACKFILL IN 9" MAXIMUM LIFTS AND RETORE DISTURBED AREA TO THE SATISFACTION OF THE ENGINEER.

CONDUIT AND WARNING TAPE TRENCH ONLY

*SEE COMMUNICATIONS CONDUIT - STANDARD INSTALLATION - PROFILE FOR PROJECT DEPTHS

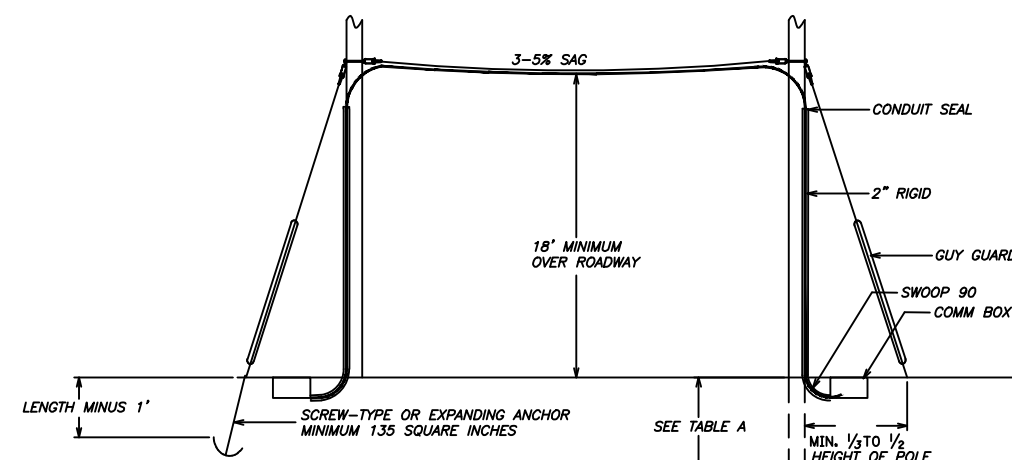

TRANSITION / SPAN DETAIL

TABLE A

POLE LENGTH - GROUND TO BUTT	
50'	7'
45'	6 1/2'
40'	6'
35'	6'
30'	5 1/2'

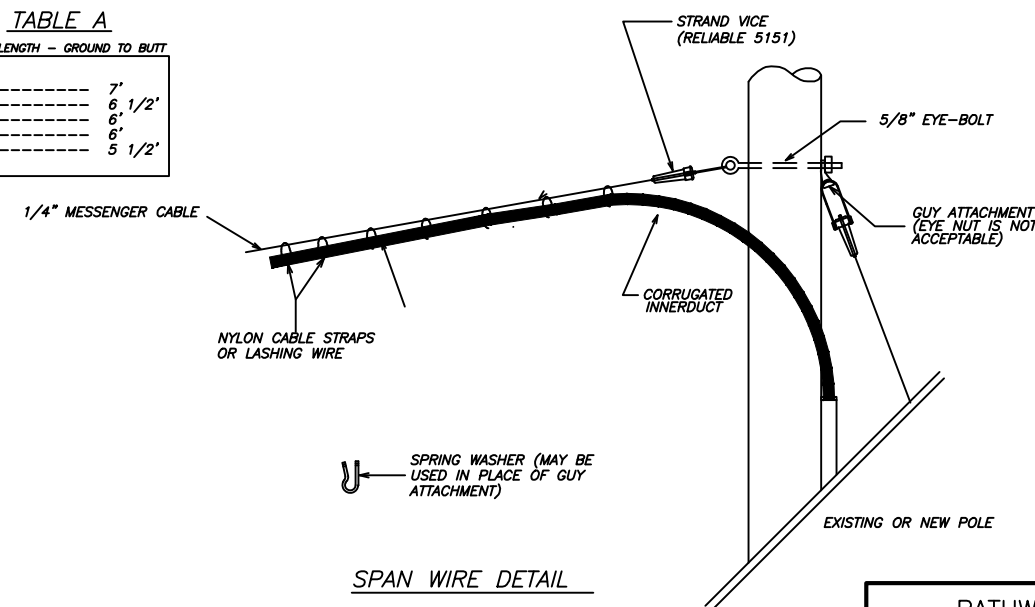

SPAN WIRE DETAIL

PATHWAY TYPICAL SECTIONS AND DETAILS

USER: \$\$\$USER\$\$\$
 DATE: \$\$\$DATE\$\$\$
 FILE NAME: \$\$\$design\$file\$specification\$\$\$
 E-SHEET NAME: _____



LEXINGTON

Lexington-Fayette Urban County Government

Lexington, Kentucky
Horse Capital of the World

Division of Procurement

Date of Issue: January 18, 2024

INVITATION TO BID # 11-2024 Fiber Optic Cable Installation & Repair

Bid Opening Date: February 1, 2024 **Bid Opening Time:** 2:00 PM
Address: All bids must be submitted on line at <https://lexingtonky.ionwave.net/>
Type of Bid: Price Contract

Pre Bid Meeting: N/A **Pre Bid Time:** N/A
Address: N/A

Sealed bids will ONLY be received online at <https://lexingtonky.ionwave.net/> until **2:00 PM**, prevailing local time on **2/01/2024**. Bids must be submitted/uploaded by the above-mentioned date and time.

Bids are to include all shipping, handling and associated fees to the point of delivery (unless otherwise specified in the bid documents below) located at: Lexington, KY

Check One:	Proposed Delivery:
<input type="checkbox"/> Yes Bid Specifications Met _____ Exceptions to Bid Specifications. <i>Exceptions shall be itemized and attached to bid proposal submitted.</i>	<input type="text" value="30"/> days after acceptance of bid.
Procurement Card Usage —The Lexington-Fayette Urban County Government may be using Procurement Cards to purchase goods and services and also to make payments. Will you accept Procurement Cards? _____ Yes <input checked="" type="checkbox"/> No	

To expedite award, the forms in this document should be completed and uploaded with your bid.

Submitted by: Gudenkauf LLC.
Firm Name

2679 Mckinley Avenue
Address

Columbus OH 43204
City, State & Zip

Bid must be signed:  General Manager
Signature of Authorized Company Representative – Title

Mark Ansboury
Representative's Name (Typed or printed)

614-488-1776
Area Code - Phone – Extension Fax #

mansboury@congruex.com
E-Mail Address

The Affidavit in this bid must be completed before your firm can be considered for award of this contract.

AFFIDAVIT

Comes the Affiant, Mark Ansboury, and after being first duly sworn under penalty of perjury as follows:

1. His/her name is Mark Ansboury and he/she is the individual submitting the bid or is the authorized representative of Gudenkauf LLC. the entity submitting the bid (hereinafter referred to as "Bidder")
2. Bidder will pay all taxes and fees, which are owed to the Lexington-Fayette Urban County Government at the time the bid is submitted, prior to award of the contract and will maintain a "current" status in regard to those taxes and fees during the life of the contract.
3. Bidder will obtain a Lexington-Fayette Urban County Government business license, if applicable, prior to award of the contract.
4. Bidder has authorized the Division of Procurement to verify the above-mentioned information with the Division of Revenue and to disclose to the Urban County Council that taxes and/or fees are delinquent or that a business license has not been obtained.
5. Bidder has not knowingly violated any provision of the campaign finance laws of the Commonwealth of Kentucky within the past five (5) years and the award of a contract to the Bidder will not violate any provision of the campaign finance laws of the Commonwealth.
6. Bidder has not knowingly violated any provision of Chapter 25 of the Lexington-Fayette Urban County Government Code of Ordinances, known as "Ethics Act."
7. Bidder acknowledges that "knowingly" for purposes of this Affidavit means, with respect to conduct or to circumstances described by a statute or ordinance defining an offense, that a person is aware or should have been aware that his conduct is of that nature or that the circumstance exists.

Further, Affiant sayeth naught. 

STATE OF Ohio

COUNTY OF Franklin

The foregoing instrument was subscribed, sworn to and acknowledged before me

by Mark Ansboury on this the 31 day of January, 2024.

My Commission expires: April 3, 2026



CHRISTY DILLARD
Notary Public
State of Ohio
My Comm. Expires
10/26

NOTARY PUBLIC, STATE AT LARGE

Please refer to Section 102B Bid Conditions, Item "U" prior to completing this form.

I. GREEN PROCUREMENT

A. ENERGY

The Lexington-Fayette Urban County Government is committed to protecting our environment and being fiscally responsible to our citizens.

The Lexington-Fayette Urban County Government mandates the use of Energy Star compliant products if they are available in the marketplace (go to www.Energystar.gov). If these products are available, but not submitted in your pricing, your bid will be rejected as non-compliant.

ENERGY STAR is a government program that offers businesses and consumers energy-efficient solutions, making it easy to save money while protecting the environment for future generations.

Key Benefits

These products use 25 to 50% less energy
Reduced energy costs without compromising quality or performance
Reduced air pollution because fewer fossil fuels are burned
Significant return on investment
Extended product life and decreased maintenance

B. GREEN SEAL CERTIFIED PRODUCTS

The Lexington-Fayette Urban County Government is also committed to using other environmentally friendly products that do not negatively impact our environment. Green Seal is a non-profit organization devoted to environmental standard setting, product certification, and public education.

Go to www.Greenseal.org to find available certified products. These products will have a reduced impact on the environment and on human health. The products to be used must be pre-approved by the LFUCG prior to commencement of any work in any LFUCG facility. If a Green Seal product is not available, the LFUCG must provide a signed waiver to use an alternate product. Please provide information on the Green Seal products being used with your bid response.

C. GREEN COMMUNITY

The Lexington-Fayette Urban County Government (LFUCG) serves as a principal, along with the University of Kentucky and Fayette County Public Schools, in the Bluegrass Partnership for a Green Community. The Purchasing Team component of the Partnership collaborates on economy of scale purchasing that promotes and enhances environmental initiatives. Specifically, when applicable, each principal is interested in obtaining best value products and/or services which promote environment initiatives via solicitations and awards from the other principals.

If your company is the successful bidder on this Invitation For Bid, do you agree to extend the same product/service pricing to the other principals of the Bluegrass Partnership for a Green Community (i.e. University of Kentucky and Fayette County Schools) if requested?

Yes No

II. Bid Conditions

- A. No bid may be withdrawn for a period of sixty (60) days after the date and time set for opening.
- B. No bid may be altered after the date and time set for opening. In the case of obvious errors, the Division of Procurement may permit the withdrawal of a bid. The decision as to whether a bid may be withdrawn shall be that of the Division of Procurement.
- C. Acceptance of this proposal shall be enactment of an Ordinance by the Urban County Council.
- D. The bidder agrees that the Urban County Government reserves the right to reject any and all bids for either fiscal

or technical reasons, and to award each part of the bid separately, all parts to one vendor or all parts to multiple vendors.

- E. Minor exceptions may not eliminate the bidder. The decision as to whether any exception is minor shall be entirely that of the head of the requisitioning Department or Division and the Director of the Division of Procurement. The Urban County Government may waive technicalities and informalities where such waiver would best serve the interests of the Urban County Government.
- F. Manufacturer's catalogue numbers, trade names, etc., where shown herein are for descriptive purposes and are to guide the bidder in interpreting the standard of quality, design, and performance desired, and shall not be construed to exclude proposals based on furnishing other types of materials and/or services. However, any substitution or departure proposed by the bidder must be clearly noted and described; otherwise, it will be assumed that the bidder intends to supply items specifically mentioned in this Invitation for Bids.
- G. The Urban County Government may require demonstrations of the materials proposed herein prior to acceptance of this proposal.
- H. Bids must be submitted on this form and must be signed by the bidder or his authorized representative. Unsigned bids will not be considered.
- I. Bids must be submitted prior to the date and time indicated for opening. Bids submitted after this time will not be considered.
- J. All bids mailed must be submitted in the Ion Wave online portal at <https://lexingtonky.ionwave.net/>
- K. Bidder is requested to show both unit prices and lot prices. In the event of error, the unit price shall prevail.
- L. A certified check or Bid Bond in the amount of XX percent of the bid price must be attached hereto. This check must be made payable to the Lexington-Fayette Urban County Government, and will be returned when the material and/or services specified herein have been delivered in accordance with specifications. In the event of failure to perform within the time period set forth in this bid, it is agreed the certified check may be cashed and the funds retained by the Lexington-Fayette Urban County Government as liquidated damages. Checks of unsuccessful bidders will be returned when the bid has been awarded.
- M. The delivery dates specified by bidder may be a factor in the determination of the successful bidder.
- N. Tabulations of bids received may be mailed to bidders. Bidders requesting tabulations must enclose a stamped, self-addressed envelope with the bid.
- O. The Lexington-Fayette Urban County Government is exempt from Kentucky Sales Tax and Federal Excise Tax on materials purchased from this bid invitation. Materials purchased by the bidder for construction projects are not tax exempt and are the sole responsibility of the bidder.
- P. All material furnished hereunder must be in full compliance with OSHA regulations.
- Q. If more than one bid is offered by one party, or by any person or persons representing a party, all such bids shall be rejected.
- R. Signature on the face of this bid by the Bidder or his authorized representative shall be construed as acceptance of and compliance with all terms and conditions contained herein.
- S. The Entity (regardless of whether construction contractor, non-construction contractor or supplier) agrees to provide equal opportunity in employment for all qualified persons, to prohibit discrimination in employment because of race, color, religion, sex (including pregnancy, sexual orientation or gender identity), national origin, disability, age, genetic information, political affiliation, or veteran status, and to promote equal employment through a positive, continuing program from itself and each of its sub-contracting agents. This program of equal employment opportunity shall apply to every aspect of its employment policies and practices.
- T. The Kentucky Equal Employment Opportunity Act of 1978 (KRS 45.560-45.640) requires that any county, city, town, school district, water district, hospital district, or other political subdivision of the state shall include in directly

or indirectly publicly funded contracts for supplies, materials, services, or equipment hereinafter entered into the following provisions:

During the performance of this contract, the contractor agrees as follows:

- (1) *The contractor will not discriminate against any employee or applicant for employment because of race, color, religion, sex, age or national origin;*
- (2) *The contractor will state in all solicitations or advertisements for employees placed by or on behalf of the contractors that all qualified applicants will receive consideration for employment without regard to race, color, religion, sex, age or national origin;*
- (3) *The contractor will post notices in conspicuous places, available to employees and applicants for employment, setting forth the provisions of the non-discrimination clauses required by this section; and*
- (4) *The contractor will send a notice to each labor union or representative of workers with which he has a collective bargaining agreement or other contract or understanding advising the labor union or workers' representative of the contractor's commitments under the nondiscrimination clauses.*

The Act further provides:

KRS 45.610. Hiring minorities - Information required

- (1) *For the length of the contract, each contractor shall hire minorities from other sources within the drawing area, should the union with which he has collective bargaining agreements be unwilling to supply sufficient minorities to satisfy the agreed upon goals and timetable.*
- (2) *Each contractor shall, for the length of the contract, furnish such information as required by KRS 45.560 to KRS 45.640 and by such rules, regulations and orders issued pursuant thereto and will permit access to all books and records pertaining to his employment practices and work sites by the contracting agency and the department for purposes of investigation to ascertain compliance with KRS 45.560 to 45.640 and such rules, regulations and orders issued pursuant thereto.*

KRS 45.620. Action against contractor - Hiring of minority contractor or subcontractor

- (1) *If any contractor is found by the department to have engaged in an unlawful practice under this chapter during the course of performing under a contract or subcontract covered under KRS 45.560 to 45.640, the department shall so certify to the contracting agency and such certification shall be binding upon the contracting agency unless it is reversed in the course of judicial review.*
- (2) *If the contractor is found to have committed an unlawful practice under KRS 45.560 to 45.640, the contracting agency may cancel or terminate the contract, conditioned upon a program for future compliance approved by the contracting agency and the department. The contracting agency may declare such a contractor ineligible to bid on further contracts with that agency until such time as the contractor complies in full with the requirements of KRS 45.560 to 45.640.*
- (3) *The equal employment provisions of KRS 45.560 to 45.640 may be met in part by a contractor by subcontracting to a minority contractor or subcontractor. For the provisions of KRS 45.560 to 45.640, a minority contractor or subcontractor shall mean a business that is owned and controlled by one or more persons disadvantaged by racial or ethnic circumstances.*

KRS 45.630 Termination of existing employee not required, when

Any provision of KRS 45.560 to 45.640 notwithstanding, no contractor shall be required to terminate an existing employee upon proof that that employee was employed prior to the date of the contract.

KRS 45.640 Minimum skills

Nothing in KRS 45.560 to 45.640 shall require a contractor to hire anyone who fails to demonstrate the minimum skills required to perform a particular job.

It is recommended that all of the provisions above quoted to be included as special conditions in each contract.

In the case of a contract exceeding \$250,000, the contractor is required to furnish evidence that his work-force in Kentucky is representative of the available work-force in the area from which he draws employees, or to supply an Affirmative Action plan which will achieve such representation during the life of the contract.

- U. Any party, firm or individual submitting a proposal pursuant to this invitation must be in compliance with the requirements of the Lexington-Fayette Urban County Government regarding taxes and fees before they can be considered for award of this invitation and must maintain a "current" status with regard to those taxes and fees throughout the term of the contract. The contractor must be in compliance with Chapter 13 from the Code of Ordinances of the Lexington-Fayette Urban County Government. The contractor must be in compliance with Ordinance 35-2000 pursuant to contractor registration with the Division of Building Inspection. If applicable, said business must have a Fayette County business license.

Pursuant to KRS 45A.343 and KRS 45A.345, the contractor shall

- (1) *Reveal any final determination of a violation by the contractor within the previous five year period pursuant to KRS Chapters 136 (corporation and utility taxes), 139 (sales and use taxes), 141 (income taxes), 337 (wages and hours), 338 (occupational safety and health of employees), 341 (unemployment and compensation) and 342 (labor and human rights) that apply to the contractor; and*
- (2) *Be in continuous compliance with the above-mentioned KRS provisions that apply to the contractor for the duration of the contract.*

A contractor's failure to reveal the above or to comply with such provisions for the duration of the contract shall be grounds for cancellation of the contract and disqualification of the contractor from eligibility for future contracts for a period of two (2) years.

- V. Vendors who respond to this invitation have the right to file a notice of contention associated with the bid process or to file a notice of appeal of the recommendation made by the Director of Procurement resulting from this invitation.

Notice of contention with the bid process must be filed within 3 business days of the bid/proposal opening by (1) sending a written notice, including sufficient documentation to support contention, to the Director of the Division of Procurement or (2) submitting a written request for a meeting with the Director of Procurement to explain his/her contention with the bid process. After consulting with the Commissioner of Finance the Chief Administrative Officer and reviewing the documentation and/or hearing the vendor, the Director of Procurement shall promptly respond in writing findings as to the compliance with bid processes. If, based on this review, a bid process irregularity is deemed to have occurred the Director of Procurement will consult with the Commissioner of Finance, the Chief Administrative Officer and the Department of Law as to the appropriate remedy.

Notice of appeal of a bid recommendation must be filed within 3 business days of the bid recommendation by (1) sending a written notice, including sufficient documentation to support appeal, to the Director, Division of Procurement or (2) submitting a written request for a meeting with the Director of Procurement to explain his appeal. After reviewing the documentation and/or hearing the vendor and consulting with the Commissioner of Finance and the Chief Administrative Officer, the Director of Procurement shall in writing, affirm or withdraw the recommendation.

III. Procurement Contract Bid Conditions

- A. The terms of this agreement shall be for 1 year(s) from the date of acceptance of this contract by the Lexington-Fayette Urban County Government. This agreement may be automatically extended for an additional 1 year(s) renewal. This contract may be canceled by either party thirty (30) days after delivery by canceling party of written notice of intent to cancel to the other contracting party.

- B. Price Changes **(Space Checked Applies)**
 - (XXX)1. Prices quoted in response to the Invitation shall be firm prices for the first 90 days of the Procurement Contract. After 90 days, prices may be subject to revision and such changes shall be based on general industry changes. Revision may be either increases or decreases and may be requested by either party. There will be no more than one (1) price adjustment per quarter. Requests for price changes shall be received in writing at least twenty (20) days prior to the effective date and are subject to written acceptance before becoming effective. Proof of the validity of a request for revision shall be responsibility of the requesting party. The Lexington-Fayette Urban County Government shall receive the benefit of any decline that the seller shall offer his other accounts.

 - () 2. No provision for price change is made herein. Prices are to be firm for the term of this contract.

 - () 3. See bid specifications.

- C. If any contract item is not available from the vendor, the Lexington-Fayette Urban County Government, at its option, may permit the item to be back-ordered or may procure the item on the open market.

- D. All invoices must bear reference to the Lexington-Fayette Urban County Government Purchasing document numbers which are being billed.

- E. This contract may be canceled by the Lexington-Fayette Urban County Government if it is determined that the Bidder has failed to perform under the terms of this agreement, such cancellation to be effective upon receipt of written notice of cancellation by the Bidder.

- F. No substitutions for articles specified herein may be made without prior approval of the Division of Procurement.

EQUAL OPPORTUNITY AGREEMENT

Standard Title VI Assurance

The Lexington Fayette-Urban County Government, (hereinafter referred to as the "Recipient") hereby agrees that as a condition to receiving any Federal financial assistance from the U.S. Department of Transportation, it will comply with Title VI of the Civil Rights Act of 1964, 78Stat.252, 42 U.S.C. 2000d-4 (hereinafter referred to as the "Act"), and all requirements imposed by or pursuant to Title 49, Code of Federal Regulations, U.S. Department of Transportation, Subtitle A, Office of the Secretary, (49 CFR, Part 21) Nondiscrimination in Federally Assisted Program of the Department of Transportation – Effectuation of Title VI of the Civil Rights Act of 1964 (hereinafter referred to as the "Regulations") and other pertinent directives, no person in the United States shall, on the grounds of race, color, national origin, sex, age (over 40), religion, sexual orientation, gender identity, veteran status, or disability be excluded from participation in, be denied the benefits of, or be otherwise subjected to discrimination under any program or activity for which the Recipient receives Federal financial assistance from the U.S. Department of Transportation, including the Federal Highway Administration, and hereby gives assurance that will promptly take any necessary measures to effectuate this agreement. This assurance is required by subsection 21.7(a) (1) of the Regulations.

The Law

- Title VII of the Civil Rights Act of 1964 (amended 1972) states that it is unlawful for an employer to discriminate in employment because of race, color, religion, sex, age (40-70 years) or national origin.
- Executive Order No. 11246 on Nondiscrimination under Federal contract prohibits employment discrimination by contractor and sub-contractor doing business with the Federal Government or recipients of Federal funds. This order was later amended by Executive Order No. 11375 to prohibit discrimination on the basis of sex.
- Section 503 of the Rehabilitation Act of 1973 states: *The Contractor will not discriminate against any employee or applicant for employment because of physical or mental disability.*
- Section 2012 of the Vietnam Era Veterans Readjustment Act of 1973 requires Affirmative Action on behalf of disabled veterans and veterans of the Vietnam Era by contractors having Federal contracts.
- Section 206(A) of Executive Order 12086, Consolidation of Contract Compliance Functions for Equal Employment Opportunity, states: *The Secretary of Labor may investigate the employment practices of any Government contractor or sub-contractor to determine whether or not the contractual provisions specified in Section 202 of this order have been violated.*

The Lexington-Fayette Urban County Government practices Equal Opportunity in recruiting, hiring and promoting. It is the Government's intent to affirmatively provide employment opportunities for those individuals who have previously not been allowed to enter into the mainstream of society. Because of its importance to the local Government, this policy carries the full endorsement of the Mayor, Commissioners, Directors and all supervisory personnel. In following this commitment to Equal Employment Opportunity and because the Government is the benefactor of the Federal funds, it is both against the Urban County Government policy and illegal for the Government to let contracts to companies which knowingly or unknowingly practice discrimination in their employment practices. Violation of the above mentioned ordinances may cause a contract to be canceled and the contractors may be declared ineligible for future consideration.

Please sign this statement in the appropriate space acknowledging that you have read and understand the provisions contained herein. Return this document as part of your application packet.

Bidders

I/We agree to comply with the Civil Rights Laws listed above that govern employment rights of minorities, women, veteran status, disability and age.

Signature

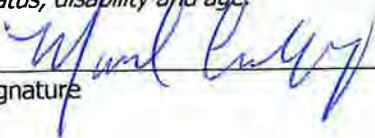

Gudenkauf LLC
Name of Business

GENERAL PROVISIONS OF BID CONTRACT

By signing the below, bidder acknowledges that it understands and agrees with the following provisions related to its bid response and the provision of any goods or services to LFUCG upon selection by LFUCG pursuant to the bid request:

1. Bidder shall comply with all Federal, State & Local regulations concerning this type of service or good. All applicable state laws, ordinances and resolutions (including but not limited to Section 2-33 (Discrimination due to sexual orientation or gender identity) and Chapter 13 (Licenses and Regulations) of the Lexington-Fayette Urban County Government Code of Ordinances, and Resolution No. 484-17 (Minority, Women, and Veteran-Owned Businesses)) and the regulations of all authorities having jurisdiction over the project shall apply to the contract, and shall be deemed to be incorporated herein by reference.
2. Failure to submit ALL forms and information required by LFUCG may be grounds for disqualification.
3. Addenda: All addenda and IonWave Q&A, if any, must be considered by the bidder in making its response, and such addenda shall be made a part of the requirements of the bid contract. Before submitting a bid response, it is incumbent upon bidder to be informed as to whether any addenda have been issued, and the failure of the bidder to cover any such addenda may result in disqualification of that response.
4. Bid Reservations: LFUCG reserves the right to reject any or all bid responses, to award in whole or part, and to waive minor immaterial defects in proposals. LFUCG may consider any alternative proposal that meets its basic needs.
5. Liability: LFUCG is not responsible for any cost incurred by bidder in the preparation of its response.
6. Changes/Alterations: Bidder may change or withdraw a proposal at any time prior to the opening; however, no oral modifications will be allowed. Only letters, or other formal written requests for modifications or corrections of a previously submitted proposal which is addressed in the same manner as the bid response, and received by LFUCG prior to the scheduled closing time for receipt of bids, will be accepted. The bid response when opened, will then be corrected in accordance with such written request(s), provided that the written request is contained in a sealed envelope which is plainly marked "modifications of bid response".
7. Clarification of Submittal: LFUCG reserves the right to obtain clarification of any point in a bid or to obtain additional information from any bidder.
8. Bribery Clause: By his/her signature on its response, bidder certifies that no employee of his/hers, any affiliate or subcontractor, has bribed or attempted to bribe an officer or employee of the LFUCG.
9. Additional Information: While not necessary, the bidder may include any product brochures, software documentation, sample reports, or other documentation that may assist LFUCG in better understanding and evaluating the bid response. Additional documentation shall not serve as a substitute for other documentation which is required by the LFUCG to be submitted with the bid response.
10. Ambiguity, Conflict or other Errors: If a bidder discovers any ambiguity, conflict, discrepancy, omission or other error in the bid request of LFUCG, it shall immediately notify LFUCG of such error in writing and request modification or clarification of the document if allowable by the LFUCG.
11. Agreement to Bid Terms: In submitting its bid response, the bidder agrees that it has carefully examined the specifications and all provisions relating to LFUCG's bid request, including but not limited to the bid contract. By submission of its bid response, bidder states that it understands the meaning, intent and requirements of LFUCG's bid request and agrees to the same. The successful bidder shall warrant that it is familiar with and understands all provisions herein and shall warrant that it can comply with them. No additional compensation to bidder shall be authorized for services, expenses, or goods reasonably covered under these provisions that the bidder omits from its bid response.
12. Cancellation: LFUCG may unilaterally terminate the bid contract with the selected bidder(s) at any time, with or without cause, by providing at least thirty (30) days advance written notice unless a different advance written notice

period is negotiated prior to contract approval. Payment for services or goods received prior to termination shall be made by the LFUCG provided these goods or services were provided in a manner acceptable to the LFUCG. Payment for those goods and services shall not be unreasonably withheld.

13. Assignment of Contract: The selected bidder(s) shall not assign or subcontract any portion of the bid contract with LFUCG without the express written consent of LFUCG. Any purported assignment or subcontract in violation hereof shall be void. It is expressly acknowledged that LFUCG shall never be required or obligated to consent to any request for assignment or subcontract; and further that such refusal to consent can be for any or no reason, fully within the sole discretion of LFUCG.
14. No Waiver: No failure or delay by LFUCG in exercising any right, remedy, power or privilege hereunder, nor any single or partial exercise thereof, nor the exercise of any other right, remedy, power or privilege shall operate as a waiver hereof or thereof. No failure or delay by LFUCG in exercising any right, remedy, power or privilege under or in respect of this bid proposal or bid contract shall affect the rights, remedies, powers or privileges of LFUCG hereunder or shall operate as a waiver thereof.
15. Authority to do Business: Each bidder must be authorized to do business under the laws of the Commonwealth of Kentucky and must be in good standing and have full legal capacity to provide the goods or services specified in the bid proposal. Each bidder must have all necessary right and lawful authority to submit the bid response and enter into the bid contract for the full term hereof including any necessary corporate or other action authorizing the bidder to submit the bid response and enter into this bid contract. If requested, the bidder will provide LFUCG with a copy of a corporate resolution authorizing this action and/or a letter from an attorney confirming that the proposer is authorized to do business in the Commonwealth of Kentucky. All bid responses must be signed by a duly authorized officer, agent or employee of the bidder.
16. Governing Law: This bid request and bid contract shall be governed by and construed in accordance with the laws of the Commonwealth of Kentucky. In the event of any proceedings regarding this matter, the bidder agrees that the venue shall be the Fayette County Circuit Court or the U.S. District Court for the Eastern District of Kentucky, Lexington Division and that the bidder expressly consents to personal jurisdiction and venue in such Court for the limited and sole purpose of proceedings relating to these matters or any rights or obligations arising thereunder.
17. Ability to Meet Obligations: Bidder affirmatively states that there are no actions, suits or proceedings of any kind pending against bidder or, to the knowledge of the bidder, threatened against the bidder before or by any court, governmental body or agency or other tribunal or authority which would, if adversely determined, have a materially adverse effect on the authority or ability of bidder to perform its obligations under this bid response or bid contract, or which question the legality, validity or enforceability hereof or thereof.
18. Price Discrepancy: When applicable, in case of price discrepancy, unit bid price written in words will prevail followed by unit price written in numbers then total amount bid per line item.
19. Bidder understands and agrees that its employees, agents, or subcontractors are not employees of LFUCG for any purpose whatsoever. Bidder is an independent contractor at all times related to the bid response or bid contract.
20. Contractor [or Vendor or Vendor's Employees] will not appropriate or make use of the Lexington-Fayette Urban County Government (LFUCG) name or any of its trade or service marks or property (including but not limited to any logo or seal), in any promotion, endorsement, advertisement, testimonial or similar use without the prior written consent of the government. If such consent is granted LFUCG reserves the unilateral right, in its sole discretion, to immediately terminate and revoke such use for any reason whatsoever. Contractor agrees that it shall cease and desist from any unauthorized use immediately upon being notified by LFUCG.
21. If any term or provision of this bid contract shall be found to be illegal or unenforceable, the remainder of the contract shall remain in full force and such term or provision shall be deemed stricken.

Signature

Date

WORKFORCE ANALYSIS FORM

Name of Organization: Gudenkauf LLC.

Categories	Total	White (Not Hispanic or Latino)		Hispanic or Latino		Black or African-American (Not Hispanic or Latino)		Native Hawaiian and Other Pacific Islander (Not Hispanic or Latino)		Asian (Not Hispanic or Latino)		American Indian or Alaskan Native (not Hispanic or Latino)		Two or more races (Not Hispanic or Latino)		Total	
		M	F	M	F	M	F	M	F	M	F	M	F	M	F	M	F
Administrators			9														
Professionals		20	4														
Superintendents																	
Supervisors		12				1											
Foremen		53															
Technicians		9	1														
Protective Service																	
Para-Professionals																	
Office/Clerical																	
Skilled Craft		175	10			5											
Service/Maintenance																	
Total:		274	24														

Prepared by: Sean Leist Estimator Date: 1 / 31 / 2024
 (Name and Title) Revised 2015-Dec-15

**DIRECTOR, DIVISION OF PROCUREMENT
LEXINGTON-FAYETTE URBAN COUNTY GOVERNMENT
200 EAST MAIN STREET
LEXINGTON, KENTUCKY 40507**

**NOTICE OF REQUIREMENT FOR AFFIRMATIVE ACTION TO ENSURE
EQUAL EMPLOYMENT OPPORTUNITIES AND DBE CONTRACT PARTICIPATION**

The Lexington-Fayette Urban County Government has set a goal that not less than ten percent (10%) of the total value of this contract be subcontracted to MBE/WBE's, and set a goal that not less than three percent (3%) of the total value of this contract be subcontracted to Veteran-Owned Small Businesses. The goal for the utilization of Certified MBE/WBE's and Veteran-Owned Small Businesses as subcontractors are recommended goals. Contractors who fail to meet such goals will be expected to provide written explanations to the Director of the Division of Procurement of efforts they have made to accomplish the recommended goals and the extent to which they are successful in accomplishing the recommended goals will be a consideration in the procurement process.

For assistance in locating MBE/WBE Subcontractors contact Sherita Miller at 859/258-3320 or by writing the address listed below:

Sherita Miller, Division of Procurement
Lexington-Fayette Urban County Government
200 East Main Street
Lexington, Kentucky 40507
smiller@lexingtonky.gov

Lexington-Fayette Urban County Government
MWDBE PARTICIPATION GOALS

A. GENERAL

- 1) The LFUCG request all potential contractors to make a concerted effort to include Minority-Owned (MBE), Woman-Owned (WBE), Disadvantaged (DBE) Business Enterprises and Veteran-Owned Small Businesses (VOSB) as subcontractors or suppliers in their bids.
- 2) Toward that end, the LFUCG has established 10% of total procurement costs as a Goal for participation of Minority-Owned, Woman-Owned and Disadvantaged Businesses on this contract.
- 3) **It is therefore a request of each Bidder to include in its bid, the same goal (10%) for MWDBE participation and other requirements as outlined in this section.**
- 4) The LFUCG has also established a 3% of total procurement costs as a Goal for participation for of Veteran-Owned Businesses.
- 5) **It is therefore a request of each Bidder to include in its bid, the same goal (3%) for Veteran-Owned participation and other requirements as outlined in this section.**

B. PROCEDURES

- 1) The successful bidder will be required to report to the LFUCG, the dollar amounts of all payments submitted to Minority-Owned, Woman-Owned or Veteran-Owned subcontractors and suppliers for work done or materials purchased for this contract. (See Subcontractor Monthly Payment Report)
- 2) Replacement of a Minority-Owned, Woman-Owned or Veteran-Owned subcontractor or supplier listed in the original submittal must be requested in writing and must be accompanied by documentation of Good Faith Efforts to replace the subcontractor / supplier with another MWDBE Firm; this is subject to approval by the LFUCG. (See LFUCG MWDBE Substitution Form)
- 3) For assistance in identifying qualified, certified businesses to solicit for potential contracting opportunities, bidders may contact:
 - a) The Lexington-Fayette Urban County Government, Division of Procurement (859-258-3320)
- 4) The LFUCG will make every effort to notify interested MWDBE and Veteran-Owned subcontractors and suppliers of each Bid Package, including information on the scope of work, the pre-bid meeting time and location, the bid date, and all other pertinent information regarding the project.

C. DEFINITIONS

- 1) A Minority-Owned Business Enterprise (MBE) is defined as a business which is certified as being at least 51% owned, managed and controlled by persons of African American, Hispanic, Asian, Pacific Islander, American Indian or Alaskan Native Heritage.
- 2) A Woman-Owned Business Enterprise (WBE) is defined as a business which is certified as being at least 51% owned, managed and controlled by one or more women.
- 3) A Disadvantaged Business (DBE) is defined as a business which is certified as being at least 51% owned, managed and controlled by a person(s) that are economically and socially disadvantaged.

- 4) A Veteran-Owned Small Business (VOSB) is defined as a business which is certified as being at least 51% owned, managed and controlled by a veteran and/or a service disabled veteran.
- 5) Good Faith Efforts are efforts that, given all relevant circumstances, a bidder or proposer actively and aggressively seeking to meet the goals, can reasonably be expected to make. In evaluating good faith efforts made toward achieving the goals, whether the bidder or proposer has performed the efforts outlined in the Obligations of Bidder for Good Faith Efforts outlined in this document will be considered, along with any other relevant factors.

D. OBLIGATION OF BIDDER FOR GOOD FAITH EFFORTS

- 1) **The bidder shall make a Good Faith Effort to achieve the Participation Goal for MWDBE and Veteran-Owned subcontractors/suppliers. The failure to meet the goal shall not necessarily be cause for disqualification of the bidder; however, bidders not meeting the goal are required to furnish with their bids written documentation of their Good Faith Efforts to do so.**
- 2) Award of Contract shall be conditioned upon satisfaction of the requirements set forth herein.
- 3) The Form of Proposal includes a section entitled "MWDBE Participation Form". The applicable information must be completed and submitted as outlined below.
- 4) **Failure to submit this information as requested may be cause for rejection of bid or delay in contract award.**

E. DOCUMENTATION REQUIRED FOR GOOD FAITH EFFORTS

- 1) Bidders reaching the Goal are required to submit only the MWDBE Participation Form." The form must be fully completed including names and telephone number of participating MWDBE firm(s); type of work to be performed; estimated value of the contract and value expressed as a percentage of the total Lump Sum Bid Price. The form must be signed and dated, and is to be submitted with the bid.
- 2) Bidders not reaching the Goal must submit the "MWDBE Participation Form", the "Quote Summary Form" and a written statement documenting their Good Faith Effort to do so. If bid includes no MWDBE and/or Veteran participation, bidder shall enter "None" on the subcontractor / supplier form). In addition, the bidder must submit written proof of their Good Faith Efforts to meet the Participation Goal:
 - a. Advertised opportunities to participate in the contract in at least two (2) publications of general circulation media; trade and professional association publications; small and minority business or trade publications; and publications or trades targeting minority, women and disadvantaged businesses not less than fifteen (15) days prior to the deadline for submission of bids to allow MWDBE firms and Veteran-Owned businesses to participate.
 - b. Included documentation of advertising in the above publications with the bidders good faith efforts package
 - c. Attended LFUCG Procurement Economic Inclusion Outreach event
 - d. Attended pre-bid meetings that were scheduled by LFUCG to inform MWDBEs and/or Veteran-Owned businesses of subcontracting opportunities

- e. Sponsored Economic Inclusion event to provide networking opportunities for prime contractors and MWDBE firms and Veteran-Owned businesses.
- f. Requested a list of MWDBE and/or Veteran subcontractors or suppliers from LFUCG and showed evidence of contacting the companies on the list(s).
- g. Contacted organizations that work with MWDBE companies for assistance in finding certified MWDBE firms and Veteran-Owned businesses to work on this project. Those contacted and their responses should be a part of the bidder's good faith efforts documentation.
- h. Sent written notices, by certified mail, email or facsimile, to qualified, certified MWDBEs and/or Veteran-Owned businesses soliciting their participation in the contract not less than seven (7) days prior to the deadline for submission of bids to allow them to participate effectively.
- i. Followed up initial solicitations by contacting MWDBEs and Veteran-Owned Businesses to determine their level of interest.
- j. Provided the interested MWDBE firm and/or Veteran-Owned business with adequate and timely information about the plans, specifications, and requirements of the contract.
- k. Selected portions of the work to be performed by MWDBE firms and/or Veteran-Owned businesses in order to increase the likelihood of meeting the contract goals. This includes, where appropriate, breaking out contract work items into economically feasible units to facilitate MWDBE and Veteran participation, even when the prime contractor may otherwise perform these work items with its own workforce
- l. Negotiated in good faith with interested MWDBE firms and Veteran-Owned businesses not rejecting them as unqualified without sound reasons based on a thorough investigation of their capabilities. Any rejection should be so noted in writing with a description as to why an agreement could not be reached.
- m. Included documentation of quotations received from interested MWDBE firms and Veteran-Owned businesses which were not used due to uncompetitive pricing or were rejected as unacceptable and/or copies of responses from firms indicating that they would not be submitting a bid.
- n. Bidder has to submit sound reasons why the quotations were considered unacceptable. The fact that the bidder has the ability and/or desire to perform the contract work with its own forces will not be considered a sound reason for rejecting a MWDBE and/or Veteran-Owned business's quote. Nothing in this provision shall be construed to require the bidder to accept unreasonable quotes in order to satisfy MWDBE and Veteran goals.
- o. Made an effort to offer assistance to or refer interested MWDBE firms and Veteran-Owned businesses to obtain the necessary equipment, supplies, materials, insurance and/or bonding to satisfy the work requirements of the bid proposal
- p. Made efforts to expand the search for MWBE firms and Veteran-Owned businesses beyond the usual geographic boundaries.

q. Other--any other evidence that the bidder submits which may show that the bidder has made reasonable good faith efforts to include MWDBE and Veteran participation.

Note: Failure to submit any of the documentation requested in this section may be cause for rejection of bid. Bidders may include any other documentation deemed relevant to this requirement which is subject to review by the MBE Liaison. Documentation of Good Faith Efforts must be submitted with the Bid, if the participation Goal is not met.



LEXINGTON

MINORITY BUSINESS ENTERPRISE PROGRAM

Sherita Miller, MPA
Minority Business Enterprise Liaison
Division of Procurement
Lexington-Fayette Urban County Government
200 East Main Street
Lexington, KY 40507
smiller@lexingtonky.gov
859-258-3323

OUR MISSION: The mission of the Minority Business Enterprise Program is to facilitate the full participation of minority and women owned businesses in the procurement process and to promote economic inclusion as a business imperative essential to the long term economic viability of Lexington-Fayette Urban County Government.

To that end the city council adopted and implemented Resolution 484-2017 – A Certified Minority, Women and Disadvantaged Business Enterprise ten percent (10%) minimum goal and a three (3%) minimum goal for Certified Veteran-Owned Small Businesses and Certified Service Disabled Veteran – Owned Businesses for government contracts.

The resolution states the following definitions shall be used for the purposes of reaching these goals (a full copy is available in Procurement):

Certified Disadvantaged Business Enterprise (DBE) – a business in which at least fifty-one percent (51%) is owned, managed and controlled by a person(s) who is socially and economically disadvantaged as defined by 49 CFR subpart 26.

Certified Minority Business Enterprise (MBE) – a business in which at least fifty-one percent (51%) is owned, managed and controlled by an ethnic minority (i.e. African American, Asian American/Pacific Islander, Hispanic Islander, Native American/Native Alaskan Indian) as defined in federal law or regulation as it may be amended from time-to-time.

Certified Women Business Enterprise (WBE) – a business in which at least fifty-one percent (51%) is owned, managed and controlled by a woman.

Certified Veteran-Owned Small Business (VOSB) – a business in which at least fifty-one percent (51%) is owned, managed and controlled by a veteran who served on active duty with the U.S. Army, Air Force, Navy, Marines or Coast Guard.

Certified Service Disabled Veteran Owned Small Business (SDVOSB) – a business in which at least fifty-one percent (51%) is owned, managed and controlled by a disabled veteran who served on active duty with the U.S. Army, Air Force, Navy, Marines or Coast Guard.

The term “Certified” shall mean the business is appropriately certified, licensed, verified, or validated by an organization or entity recognized by the Division of Purchasing as having the appropriate credentials to make a determination as to the status of the business.

To comply with Resolution 484-2017, prime contractors and minority, women and veteran owned businesses must enroll in the new Diverse Business Management Compliance system, <https://lexingtonky.diversitycompliance.com/>

We have compiled the list below to help you locate certified MBE, WBE and DBE certified businesses. Below is a listing of contacts for LFUCG Certified MWDBEs and Veteran-Owned Small Businesses in (<https://lexingtonky.ionwave.net>)

Business	Contact	Email Address	Phone
LFUCG	Sherita Miller	smiller@lexingtonky.gov	859-258-3323
Commerce Lexington – Minority Business Development	Tyrone Tyra	ttyra@commercelexington.com	859-226-1625
Tri-State Minority Supplier Diversity Council	Susan Marston	smarston@tsmsdc.com	502-365-9762
Small Business Development Council	Shawn Rogers UK SBDC	shawn.rogers@uky.edu	859-257-7666
Community Ventures Corporation	Phyllis Alcorn	palcorn@cvky.org	859-231-0054
KY Transportation Cabinet (KYTC)	Melvin Bynes	Melvin.bynes2@ky.gov	502-564-3601
KYTC Pre-Qualification	Sheila Eagle	Sheila.Eagle@ky.gov	502-782-4815
Ohio River Valley Women’s Business Council (WBENC)	Sheila Mixon	smixon@orvwbc.org	513-487-6537
Kentucky MWBE Certification Program	Yvette Smith, Kentucky Finance Cabinet	Yvette.Smith@ky.gov	502-564-8099
National Women Business Owner’s Council (NWBOC)	Janet Harris-Lange	janet@nwvoc.org	800-675-5066
Small Business Administration	Robert Coffey	robertcoffey@sba.gov	502-582-5971
LaVoz de Kentucky	Andres Cruz	lavozdeky@yahoo.com	859-621-2106
The Key News Journal	Patrice Muhammad	production@keynewsjournal.com	859-685-8488



LFUCG MWDBE PARTICIPATION FORM

Bid/RFP/Quote Reference # _____

The MWDBE and/or veteran subcontractors listed have agreed to participate on this Bid/RFP/Quote. If any substitution is made or the total value of the work is changed prior to or after the job is in progress, it is understood that those substitutions must be submitted to Procurement for approval immediately. **Failure to submit a completed form may cause rejection of the bid.**

MWDBE Company, Name, Address, Phone, Email	MBE WBE or DBE	Work to be Performed	Total Dollar Value of the Work	% Value of Total Contract
1.				
2.				
3.				
4.				

The undersigned company representative submits the above list of MWDBE firms to be used in accomplishing the work contained in this Bid/RFP/Quote. Any misrepresentation may result in the termination of the contract and/or be subject to applicable Federal and State laws concerning false statements and false claims.

N/A
Company

Company Representative

Date

Title



LFUCG MWDBE PARTICIPATION FORM

Bid/RFP/Quote Reference # _____

The MWDBE and/or veteran subcontractors listed have agreed to participate on this Bid/RFP/Quote. If any substitution is made or the total value of the work is changed prior to or after the job is in progress, it is understood that those substitutions must be submitted to Procurement for approval immediately. **Failure to submit a completed form may cause rejection of the bid.**

MWDBE Company, Name, Address, Phone, Email	MBE WBE or DBE	Work to be Performed	Total Dollar Value of the Work	% Value of Total Contract
1.				
2.				
3.				
4.				

The undersigned company representative submits the above list of MWDBE firms to be used in accomplishing the work contained in this Bid/RFP/Quote. Any misrepresentation may result in the termination of the contract and/or be subject to applicable Federal and State laws concerning false statements and false claims.

N/A

Company

Company Representative

Date

Title



LEXINGTON

LFUCG MWDBE SUBSTITUTION FORM

Bid/RFP/Quote Reference # _____

The substituted MWDBE and/or veteran subcontractors listed below have agreed to participate on this Bid/RFP/Quote. These substitutions were made prior to or after the job was in progress. These substitutions were made for reasons stated below and are now being submitted to Procurement for approval. By the authorized signature of a representative of our company, we understand that this information will be entered into our file for this project. **Failure to submit this form may cause rejection of the bid.**

SUBSTITUTED MWDBE Company Name, Address, Phone, Email	MWDBE Formally Contracted/ Name, Address, Phone, Email	Work to Be Performed	Reason for the Substitution	Total Dollar Value of the Work	% Value of Total Contract
1.					
2.					
3.					
4.					

The undersigned acknowledges that any misrepresentation may result in termination of the contract and/or be subject to applicable Federal and State laws concerning false statements and false claims.

N/A
Company

Company Representative

Date

Title



LEXINGTON

MWDBE QUOTE SUMMARY FORM

Bid/RFP/Quote Reference # _____

The undersigned acknowledges that the minority and/or veteran subcontractors listed on this form did submit a quote to participate on this project. Failure to submit this form may cause rejection of the bid.

Company Name	Contact Person
Address/Phone/Email	Bid Package / Bid Date

MWDBE Company Address	Contact Person	Contact Information (work phone, Email, cell)	Date Contacted	Services to be performed	Method of Communication (email, phone meeting, ad, event etc)	Total dollars \$\$ Do Not Leave Blank (Attach Documentation)	MBE * AA HA AS NA Female	Veteran

(MBE designation / AA=African American / HA= Hispanic American/AS = Asian American/Pacific Islander/ NA= Native American)

The undersigned acknowledges that all information is accurate. Any misrepresentation may result in termination of the contract and/or be subject to applicable Federal and State laws concerning false statements and claims.

N/A
Company

Company Representative

Date

Title



LEXINGTON

LFUCG SUBCONTRACTOR MONTHLY PAYMENT REPORT

The LFUCG has a 10% goal plan adopted by city council to increase the participation of minority and women owned businesses in the procurement process. The LFUCG also has a 3% goal plan adopted by cited council to increase the participation of veteran owned businesses in the procurement process. In order to measure that goal LFUCG will track spending with MWDBE and Veteran contractors on a monthly basis. By the signature below of an authorized company representative, you certify that the information is correct, and that each of the representations set forth below is true. Any misrepresentation may result in termination of the contract and/or prosecution under applicable Federal and State laws concerning false statements and false claims. Please submit this form monthly to the Division of Procurement/ 200 East Main Street/ Lexington, KY 40507.

Bid/RFP/Quote # _____
 Total Contract Amount Awarded to Prime Contractor for this Project _____

Project Name/ Contract #	Work Period/ From: _____ To: _____
Company Name:	Address: _____
Federal Tax ID:	Contact Person: _____

Subcontractor Vendor ID (name, address, phone, email)	Description of Work	Total Subcontract Amount	% of Total Contract Awarded to Prime for this Project	Total Amount Paid for this Period	Purchase Order number for subcontractor work (please attach PO)	Scheduled Project Start Date	Scheduled Project End Date

By the signature below of an authorized company representative, you certify that the information is correct, and that each of the representations set forth below is true. Any misrepresentations may result in the termination of the contract and/or prosecution under applicable Federal and State laws concerning false statements and false claims.

N/A

 Company

 Company Representative

 Date

 Title

LFUCG STATEMENT OF GOOD FAITH EFFORTS

Bid/RFP/Quote # _____

By the signature below of an authorized company representative, we certify that we have utilized the following Good Faith Efforts to obtain the maximum participation by MWDBE and Veteran-Owned business enterprises on the project and can supply the appropriate documentation.

_____ Advertised opportunities to participate in the contract in at least two (2) publications of general circulation media; trade and professional association publications; small and minority business or trade publications; and publications or trades targeting minority, women and disadvantaged businesses not less than fifteen (15) days prior to the deadline for submission of bids to allow MWDBE firms and Veteran-Owned businesses to participate.

_____ Included documentation of advertising in the above publications with the bidders good faith efforts package

_____ Attended LFUCG Procurement Economic Inclusion Outreach event

_____ Attended pre-bid meetings that were scheduled by LFUCG to inform MWDBEs and/or Veteran-Owned Businesses of subcontracting opportunities

_____ Sponsored Economic Inclusion event to provide networking opportunities for prime contractors and MWDBE firms and Veteran-Owned businesses

_____ Requested a list of MWDBE and/or Veteran subcontractors or suppliers from LFUCG and showed evidence of contacting the companies on the list(s).

_____ Contacted organizations that work with MWDBE companies for assistance in finding certified MWDBE firms and Veteran-Owned businesses to work on this project. Those contacted and their responses should be a part of the bidder's good faith efforts documentation.

_____ Sent written notices, by certified mail, email or facsimile, to qualified, certified MWDBEs soliciting their participation in the contract not less than seven (7) days prior to the deadline for submission of bids to allow them to participate effectively.

_____ Followed up initial solicitations by contacting MWDBEs and Veteran-Owned businesses to determine their level of interest.

_____ Provided the interested MWDBE firm and/or Veteran-Owned business with adequate and timely information about the plans, specifications, and requirements of the contract.

_____ Selected portions of the work to be performed by MWDBE firms and/or Veteran-Owned businesses in order to increase the likelihood of meeting the contract goals. This includes, where appropriate, breaking out contract work items into economically feasible units to facilitate MWDBE and Veteran participation, even when the prime contractor may otherwise perform these work items with its own workforce

_____ Negotiated in good faith with interested MWDBE firms and Veteran-Owned businesses not rejecting them as unqualified without sound reasons based on a thorough investigation of their capabilities. Any rejection should be so noted in writing with a description as to why an agreement could not be reached.

_____ Included documentation of quotations received from interested MWDBE firms and

Veteran-Owned businesses which were not used due to uncompetitive pricing or were rejected as unacceptable and/or copies of responses from firms indicating that they would not be submitting a bid.

_____ Bidder has to submit sound reasons why the quotations were considered unacceptable. The fact that the bidder has the ability and/or desire to perform the contract work with its own forces will not be considered a sound reason for rejecting a MWDBE and/or Veteran-Owned business's quote. Nothing in this provision shall be construed to require the bidder to accept unreasonable quotes in order to satisfy MWDBE and Veteran goals.

_____ Made an effort to offer assistance to or refer interested MWDBE firms and Veteran-Owned businesses to obtain the necessary equipment, supplies, materials, insurance and/or bonding to satisfy the work requirements of the bid proposal

_____ Made efforts to expand the search for MWBE firms and Veteran-Owned businesses beyond the usual geographic boundaries.

_____ Other--any other evidence that the bidder submits which may show that the bidder has made reasonable good faith efforts to include MWDBE and Veteran participation.

NOTE: Failure to submit any of the documentation requested in this section may be cause for rejection of bid. Bidders may include any other documentation deemed relevant to this requirement which is subject to approval by the MBE Liaison. Documentation of Good Faith Efforts must be submitted with the Bid, if the participation Goal is not met.

The undersigned acknowledges that all information is accurate. Any misrepresentations may result in termination of the contract and/or be subject to applicable Federal and State laws concerning false statements and claims.

N/A

Company

Date

Company Representative

Title

**AMENDMENT 1 —
CERTIFICATION OF COMPLIANCE FOR EXPENDITURES USING FEDERAL FUNDS,
INCLUDING THE AMERICAN RESCUE PLAN ACT**

The Lexington-Fayette Urban County Government (“LFUCG”) may use Federal funding to pay for the goods and/or services that are the subject matter of this bid. That Federal funding may include funds received by LFUCG under the American Rescue Plan Act of 2021. Expenditures using Federal funds require evidence of the contractor’s compliance with Federal law. Therefore, by the signature below of an authorized company representative, you certify that the information below is understood, agreed, and correct. Any misrepresentations may result in the termination of the contract and/or prosecution under applicable Federal and State laws concerning false statements and false claims.

The bidder (hereafter “bidder,” or “contractor”) agrees and understands that in addition to all conditions stated within the attached bid documents, the following conditions will also apply to any Agreement entered between bidder and LFUCG, if LFUCG uses Federal funds, including but not limited to funding received by LFUCG under the American Rescue Plan Act (“ARPA”), toward payment of goods and/or services referenced in this bid. The bidder also agrees and understands that if there is a conflict between the terms included elsewhere in this Request for Proposal and the terms of this Amendment 1, then the terms of Amendment 1 shall control. The bidder further certifies that it can and will comply with these conditions, if this bid is accepted and an Agreement is executed:

1. Any Agreement executed as a result of acceptance of this bid may be governed in accordance with 2 CFR Part 200 and all other applicable Federal law and regulations and guidance issued by the U.S. Department of the Treasury.
2. Pursuant to 24 CFR § 85.43, any Agreement executed as a result of acceptance of this bid can be terminated if the contractor fails to comply with any term of the award. This Agreement may be terminated for convenience in accordance with 24 CFR § 85.44 upon written notice by LFUCG. Either party may terminate this Agreement with thirty (30) days written notice to the other party, in which case the Agreement shall terminate on the thirtieth day. In the event of termination, the contractor shall be entitled to that portion of total compensation due under this Agreement as the services rendered bears to the services required. However, if LFUCG suspects a breach of the terms of the Agreement and/or that the contractor is violating the terms of any applicable law governing the use of Federal funds, LFUCG may suspend the contractor’s ability to receive payment by giving thirty (30) days’ advance written notice. Further, either party may terminate this Agreement for cause shown with thirty (30) days written notice, which shall explain the party’s cause for the termination. If the parties do not reach a settlement before the end of the 30 days, then the Agreement shall terminate on the thirtieth day. In the event of a breach, LFUCG reserves the right to pursue any and all applicable legal, equitable, and/or administrative remedies against the contractor.
3. The contractor will not discriminate against any employee or applicant for employment because of race, color, religion, sex, sexual orientation, gender identity, or national origin. The contractor will take affirmative action to ensure that applicants are employed and that employees are treated during employment without regard to their race, color, religion, sex, sexual orientation, gender identity, or national origin. Such action shall include, but not be limited to the following:
 - (1) Employment, upgrading, demotion, or transfer; recruitment or recruitment advertising; layoff or termination; rates of pay or other forms of compensation; and selection for training, including apprenticeship. The contractor agrees to post in conspicuous places, available to employees and applicants for employment, notices to be provided setting forth the provisions of this nondiscrimination clause.

- (2) The contractor will, in all solicitations or advertisements for employees placed by or on behalf of the contractor, state that all qualified applicants will receive consideration for employment without regard to race, color, religion, sex, sexual orientation, gender identity, or national origin.
- (3) The contractor will not discharge or in any other manner discriminate against any employee or applicant for employment because such employee or applicant has inquired about, discussed, or disclosed the compensation of the employee or applicant or another employee or applicant. This provision shall not apply to instances in which an employee who has access to the compensation information of other employees or applicants as a part of such employee's essential job functions discloses the compensation of such other employees or applicants to individuals who do not otherwise have access to such information, unless such disclosure is in response to a formal complaint or charge, in furtherance of an investigation, proceeding, hearing, or action, including an investigation conducted by the employer, or is consistent with the contractor's legal duty to furnish information.
- (4) The contractor will send to each labor union or representative of workers with which he has a collective bargaining agreement or other contract or understanding a notice to be provided advising the said labor union or workers' representatives of the contractor's commitments under this section and shall post copies of the notice in conspicuous places available to employees and applicants for employment.
- (5) The contractor will comply with all provisions of Executive Order 11246 of September 24, 1965, and of the rules, regulations, and relevant orders of the Secretary of Labor.
- (6) The contractor will furnish all information and reports required by Executive Order 11246 of September 24, 1965, and by rules, regulations, and orders of the Secretary of Labor, or pursuant thereto, and will permit access to his books, records, and accounts by the administering agency and the Secretary of Labor for purposes of investigation to ascertain compliance with such rules, regulations, and orders.
- (7) In the event of the contractor's noncompliance with the nondiscrimination clauses of this contract or with any of the said rules, regulations, or orders, this contract may be canceled, terminated, or suspended in whole or in part, and the contractor may be declared ineligible for further government contracts or federally assisted construction contracts in accordance with procedures authorized in Executive Order 11246 of September 24, 1965, and such other sanctions may be imposed and remedies invoked as provided in Executive Order 11246 of September 24, 1965, or by rule, regulation, or order of the Secretary of Labor, or as otherwise provided by law.
- (8) The contractor will include the portion of the sentence immediately preceding paragraph (1) and the provisions of paragraphs (1) through (8) in every subcontract or purchase order unless exempted by rules, regulations, or orders of the Secretary of Labor issued pursuant to section 204 of Executive Order 11246 of September 24, 1965, so that such provisions will be binding upon each subcontractor or vendor. The contractor will take such action with respect to any subcontract or purchase order as the administering agency may direct as a means of enforcing such provisions, including sanctions for noncompliance.

Provided, however, that in the event a contractor becomes involved in or is threatened with litigation with a subcontractor or vendor as a result of such direction by the administering agency, the contractor may request the United States to enter into such litigation to protect the interests of the United States.

4. If fulfillment of the contract requires the contractor to employ mechanic's or laborers, the contractor further agrees that it can and will comply with the following:

- (1) Overtime requirements: No contractor or subcontractor contracting for any part of the contract work which may require or involve the employment of laborers or mechanics shall require or permit any such laborer or mechanic in any workweek in which he or she is employed on such work to work in excess of forty hours in such a workweek unless such laborer or mechanic receives compensation at a rate not less than one and one-half times the basic rate of pay for all hours worked in excess of forty hours in such a workweek.
- (2) Violation: liability for unpaid wages; liquidated damages. In the event of any violation of the clause set forth in paragraph (1) of this section, the contractor and any subcontractor responsible therefor shall be liable for

the unpaid wages. In addition, such contractor and subcontractor shall be liable to the United States (in the case of work done under contract for the District of Columbia or a territory, to such District or to such territory) for liquidated damages. Such liquidated damages shall be computed with respect to each individual laborer or mechanic, including watchmen and guards, employed in violation of the clause set forth in paragraph (1) of this section, in the sum of \$10 for each calendar day on which such individual was required or permitted to work in excess of the standard workweek of forty hours without payment of the overtime wages required by the clause set forth in paragraph (1) of this section.

(3) Withholding for unpaid wages and liquidated damages. LFUCG shall upon its own action or upon written request of an authorized representative of the Department of Labor withhold or cause to be withheld, from any moneys payable on account of work performed by the contractor or subcontractor under any such contract or any other federal contract with the same prime contractor, or any other federally-assisted contract subject to the Contract Work Hours and Safety Standards Act, which is held by the same prime contractor, such sums as may be determined to be necessary to satisfy any liabilities of such contractor or subcontractor for unpaid wages and liquidated damages as provided in the clause set forth in paragraph (2) of this section.

(4) Subcontracts. The contractor or subcontractor shall insert in any subcontracts the clauses set forth in paragraph (1) through (4) of this section and also a clause requiring the subcontractors to include these clauses in any lower-tier subcontracts. The prime contractor shall be responsible for compliance by any subcontractor or lower-tier subcontractor with the clauses set forth in paragraphs (1) through (4) of this section.

5. The contractor shall comply with all applicable standards, orders, or regulations issued pursuant to the Clean Air Act, as amended, 42 U.S.C. § 7401 et seq.

6. The contractor shall report each violation to LFUCG and understands and agrees that LFUCG will, in turn, report each violation as required to assure notification to the Treasury Department and the appropriate Environmental Protection Agency Regional Office.

7. The contractor shall include these requirements in numerical paragraphs 5 and 6 in each subcontract exceeding \$100,000 financed in whole or in part with Federal funding.

8. The contractor shall comply with all applicable standards, orders, or regulations issued pursuant to the Federal Water Pollution Control Act, as amended, 33 U.S.C. § 1251 et seq.

9. The contractor shall report each violation to LFUCG and understands and agrees that LFUCG will, in turn, report each violation as required to assure notification to the Treasury Department and the appropriate Environmental Protection Agency Regional Office.

10. The contractor shall include these requirements in numerical paragraphs 8 and 9 in each subcontract exceeding \$100,000 financed in whole or in part with Federal funds.

11. The contractor shall comply with all applicable standards, orders, or regulations issued pursuant to the Federal Water Pollution Control Act, as amended, 33 U.S.C. § 1251 et seq.

12. The contractor shall report each violation to LFUCG and understands and agrees that LFUCG will, in turn, report each violation as required to assure notification to the Treasury Department and the appropriate Environmental Protection Agency regional office.

13. The contractor shall include these requirements in numerical paragraphs 11 and 12 in each subcontract exceeding \$100,000 financed in whole or in part with American Rescue Plan Act funds.

14. The contractor shall include this language in any subcontract it executes to fulfill the terms of this bid: "the subgrantee, contractor, subcontractor, successor, transferee, and assignee shall comply with Title VI of the Civil Rights

Act of 1964, which prohibits recipients of federal financial assistance from excluding from a program or activity, denying benefits of, or otherwise discriminating against a person on the basis of race, color, or national origin (42 U.S.C. § 2000d et seq.), as implemented by the Department of the Treasury's Title VI regulations, 31 CFR Part 22, which are herein incorporated by reference and made a part of this contract (or agreement). Title VI also includes protection to persons with 'Limited English Proficiency' in any program or activity receiving federal financial assistance, 42 U.S.C. § 2000d et seq., as implemented by the Department of the Treasury's Title VI regulations, 31 CFR Part 22, and herein incorporated by reference and made a part of this contract or agreement."

15. Contractors who apply or bid for an award of \$100,000 or more shall file the required certification that it will not and has not used federal appropriated funds to pay any person or organization for influencing or attempting to influence an officer or employee of any agency. Each tier certifies to the tier above that it will not and has not used federal appropriated funds to pay any person or organization for influencing or attempting to influence an officer or employee of any agency, a member of Congress, officer or employee of Congress, or an employee of a member of Congress in connection with obtaining any federal contract, grant, or any other award covered by 31 U.S.C. § 1352. Each tier shall also disclose any lobbying with non-federal funds that takes place in connection with obtaining any federal award. Such disclosures are forwarded from tier to tier, up to the recipient. The required certification is included here:

a. The undersigned certifies, to the best of his or her knowledge and belief, that:

- (1) No Federal appropriated funds have been paid or will be paid, by or on behalf of the undersigned, to any person for influencing or attempting to influence an officer or employee of an agency, a Member of Congress, an officer or employee of Congress, or an employee of a Member of Congress in connection with the awarding of any Federal contract, the making of any Federal grant, the making of any Federal loan, the entering into of any cooperative agreement, and the extension, continuation, renewal, amendment, or modification of any Federal contract, grant, loan, or cooperative agreement.
- (2) If any funds other than Federal appropriated funds have been paid or will be paid to any person for influencing or attempting to influence an officer or employee of any agency, a Member of Congress, an officer or employee of Congress, or an employee of a Member of Congress in connection with this Federal contract, grant, loan, or cooperative agreement, the undersigned shall complete and submit Standard Form-LLL, "Disclosure Form to Report Lobbying," in accordance with its instructions.
- (3) The undersigned shall require that the language of this certification be included in the award documents for all subawards at all tiers (including subcontracts, subgrants, and contracts under grants, loans, and cooperative agreements) and that all subrecipients shall certify and disclose accordingly.

b. This certification is a material representation of fact upon which reliance was placed when this transaction was made or entered into. Submission of this certification is a prerequisite for making or entering into this transaction imposed by section 1352, title 31, U.S. Code. Any person who fails to file the required certification shall be subject to a civil penalty of not less than \$10,000 and not more than \$100,000 for each such failure.

16. The contractor acknowledges and certifies that it has not been debarred or suspended and further acknowledges and agrees that it must comply with regulations regarding debarred or suspended entities in accordance with 24 CFR § 570.489(1). Funds may not be provided to excluded or disqualified persons.

17. The contractor agrees and certifies that to the greatest extent practicable, it will prefer the purchase, acquisition, and use of all applicable goods, products or materials produced in the United States, in conformity with 2 CFR 200.322 and/or section 70914 of Public Law No. 117-58, §§ 70901-52, also known as the Infrastructure Investment and Jobs Act, whichever is applicable.

18. The contractor agrees and certifies that all activities performed pursuant to any Agreement entered as a result of the contractor's bid, and all goods and services procured under that Agreement, shall comply with 2 C.F.R. § 200.216 (Prohibition on certain telecommunications and video surveillance services and equipment) and 2 C.F.R. 200 § 200.323 (Procurement of recovered materials), to the extent either section is applicable.

19. If this bid involves construction work for a project totaling \$10 million or more, then the contractor further agrees that all laborers and mechanics, etc., employed in the construction of the public facility project assisted with funds provided under this Agreement, whether employed by contractor, or contractor's contractors, or subcontractors, shall be paid wages complying with the Davis-Bacon Act (40 U.S.C. 3141-3144). Contractor agrees that all of contractor's contractors and subcontractors will pay laborers and mechanics the prevailing wage as determined by the Secretary of Labor and that said laborers and mechanics will be paid not less than once a week. The contractor agrees to comply with the Copeland Anti- Kick Back Act (18 U.S.C. § 874) and its implementing regulations of the U.S. Department of Labor at 29 CFR part 3 and part 5. The contractor further agrees to comply with the applicable provisions of the Contract Work Hours and Safety Standards Act (40 U.S.C. Section 327-333), and the applicable provisions of the Fair Labor Standards Act of 1938, as amended (29 U.S.C. et seq.). Contractor further agrees that it will report all suspected or reported violations of any of the laws identified in this paragraph to LFUCG.

Signature

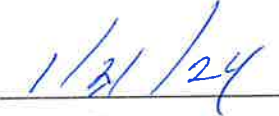
Date



LEXINGTON

Lexington-Fayette Urban County Government
Division of Traffic Engineering
Bid #11-2024 Fiber Optic Cable Install & Repair

The Lexington Fayette Urban County Government, Department of Environmental Quality & Public Works, Division of Traffic Engineering, requests proposals of a price contract to consist of all items and activities involved in Fiber-Optic Cable and Pathway Installation and Repair.

Bidder Requirements:

The successful bidder shall:

- Submit copies of all required licenses and certifications with the bid.
- Be a licensed contractor in Fayette County.
- Cannot subcontract any work without prior approval from LFUCG Traffic Engineering.
- Have a certified fiber-optic cable installer on site at all times overseeing/performing fiber-optic cable installation work.
- Have a certified Fusion Splicer perform all fusion splicing work (when such work is needed).
- Have an IMSA Certified Level II - Traffic Signal Technician on site, overseeing work performed around traffic signal equipment. *LFUCG shall perform this function if requested, at the Technician Rate specified below.
- Install fiber-optic cable equipment/materials meeting LFUCG Division of Traffic Engineering specifications.
- Complete any/all work within thirty (30) days from notice to proceed. *Special consideration will be given for larger projects such as underground installs greater than 5,000 feet.
- Post a performance bond equal to any single fiber project costs exceeding \$50,000.
- Comply with Division of Engineering requirements for roadway cuts, trenching, sidewalk work and restoration.
- Obtain Lane Closure Permits from Traffic Engineering as needed for work within the public right-of-way.

Enforcement Codes and Standards:

All work shall conform to the:

- National Electrical Code
- National Safety Code
- International Municipal Signal Association
- Manual on Uniform Traffic Control Devices
- Work Zone Traffic Control Codes
- Lexington Fayette Urban County Government or State Highway Department codes relevant to work being done.
- Reduction of Soil Erosion (LFUCG Code of Ordinances) Chapter 16, Article X, Division 5, Section 16-103
- BICSI G1: OSP

Payment:

- Payment for work performed shall be, after all work has been completed, inspected, and has met all specifications listed on plans and enforcement codes. Partial payments will be made on larger projects lasting more than one month.
- Payment for conduit installed shall be on a per foot basis and shall include all the necessary components needed to complete the installation (Example: Condulets, conduit

hangers, couplings, stand-offs, etc.)

Conduits:

- All conduits installed shall be Sch 80/SDR 11.
- All trunk-line conduits shall be 2" Inner-Duct, HDPE, Orange.
- All PVC conduits installed shall have a threaded PVC bushing installed on the end.
- All conduits installed under roadway surfaces shall be encased in concrete or directionally bored per KYTC/LFUCG specifications.
- All conduits entering into junction boxes and/or traffic signal equipment shall be non-metallic, except where conduit extends above surface grade level.
- All rigid steel conduits installed by the contractor per this contract shall be bonded to ground and have threaded bushings on the ends.
- All conduits installed above grade shall be rigid steel (including preformed 90's that attach to underground conduit) unless specified otherwise by the Division of Traffic Engineering.
- All conduits installed shall be connected to existing conduits, junction boxes and/or traffic signal equipment, if present.
- Installation of Conduits, on wood poles shall be mounted using standoffs (number of conduits shall be determined by the LFUCG).

The following items shall be considered a part of each bid item and the LFUCG shall not be billed separately for these items:

- Any/All Equipment and manpower needed, to perform work outlined in bid item.
- Any/All Electrical and misc. materials used/needed to complete the work to meet applicable codes and specifications.
- Material acquisition and transport.
- Cleaning up of dirt, debris, materials, etc.
- Discarding of materials.
- Locating of utilities.
- Repair costs for damages to private property or utilities caused by the contractor (whether items are listed on the plans or not).
- Restoring of the work site back to its original condition, in most cases using typical Best Practices for restoring work sites.
- All local permits as necessary (R/W Permit, Land Disturbance Permit and Lane Blockage Permit). Permit fees (Permit fees (if any) will be covered by the Division. Fines associated with the permits will not be covered by the Division.
- Traffic control needed. Note: Most work associated with this contract will be in and around busy roadways in Fayette County.
- Any repairs due to malfunctions or adjustments caused by contractor carelessness or negligence for thirty (30) days after final approval.

Technical Assistance:

If requested by the contractor/developer or required due to unsafe conditions or need for IMSA Level II oversight, the LFUCG shall provide technical assistance for \$100 per call-out plus \$40 per hour after two hours.

The scope of work shall be as follows:

- The division may request the contractor, perform such work as (but not limited to), installing wood poles, anchors, replacing fiber-optic cable support spans, underground conduit, junction boxes, installing fiber-optic cable, fusion splicing fiber-optic cable and making fiber-optic cable wiring connections.
- The Division of Traffic Engineering may elect to have the vendor do all of the work or do only part of the work with the Division of Traffic Engineering completing the work.
- The contractor will be required to provide and/or obtain materials (Electrical, anchoring, and line hardware) to install fiber-optic cable and equipment with the exception of traffic signal equipment (See bid item specifications).

The following equipment and/or labor shall be required:

- Laborer
- Foreman
- Electrician
- Certified fiber-optic cable installer/splicer
- Fiber-Optic Cable installation and Fusion Splicing equipment
- Pickup Truck
- One 1&1/2 Ton Bucket Truck
- 1&1/2 Ton Platform Truck
- 1&1/2 Ton Line Truck and Auger
- Concrete Saw (Min 35 HP) with Blades
- Air Compressor (Min 125 CFM) with Tools
- Trenching Machine (up to 42")
- Flashing Arrow Board
- Backhoe
- Pipe Pusher
- Boring Machine (2" hole)
- Mobile environmentally controlled splicing enclosure (Example: Splice Trailer)

The LFUCG may inspect facilities and equipment before award of bid.

The following list, gives the contractor an idea of some of the materials he/she shall be required to provide and/or obtain (but not limited to). Other materials that the contractor may be required to provide and/or obtain shall be as outlined within the contract relative to specific bid item numbers:

- Materials to install Down Guys and Side Walk Guys including Expansion Anchors, Guy Guards, Line Hardware etc. (2-inch Hardware and 2-inch rigid steel conduit shall be used for sidewalk guys.
- 1/4-inch Messenger Cable (Span Wire).
- Reliable (1/4-inch) Strand Vises.
- Materials to install conduits into a controller cabinet (strain pole or wood pole mount).
- Concrete, wood and materials needed to install concrete platforms or make concrete repairs.
- Other needed materials not listed (Electrical, Anchoring, and Line Hardware) needed to install Fiber-Optic Cable (except Fiber-Optic Cable).

Bid item specifications:

The phrase Fiber-Optic Cable Equipment in the following bid activities may consist of all or part of the following:

- Fiber-Optic Cable Mounting Hardware.
- Fiber-Optic Cable Support Cable.
- 1/4-inch messenger cable.
- 1/4-inch strand vises
- In ground junction box
- Fiber-Optic Cable & Components.
- Inner-duct
- Detectable Pull String

Bid Activities

Contractor should give price quotes for the following items.

01. Wood Pole, 35-foot, Class 4:

- Provide and install wood pole

02. Wood Pole, 45-foot, Class 4:

- Provide and install wood pole

03. Down Guy (Standard):

- Contractor shall provide all material and equipment (including guy guard) in concrete or soil.
- Contractor shall use expansion type anchor with an 8-foot anchor rod.
- 8M Galvanized messenger cable and 5/16-inch strand vises shall be used.

04. Down Guy (Sidewalk):

- Contractor shall provide all material and equipment (including guy guard) in concrete or soil.
- Contractor shall use 2-inch pole plate and end cap.
- Contractor shall use expansion type anchor with an 8-foot anchor rod.
- 8M Galvanized messenger cable and 5/16-inch strand vises shall be used.

05. Span Wire (Messenger Cable):

- Contractor shall provide and install all materials
- 1/4-inch messenger cable

06. Conduit, Above Ground, Rigid Steel 2 inch

- Contractor shall supply all material and equipment
- Contractor shall connect to existing conduits, junction boxes, poles, etc.

07. Conduit, Underground, Non Traffic Surface, 2-Inch

- Contractor shall provide all materials and equipment.
- Contractor shall connect to existing conduits, junction boxes, poles, etc.
- Installation method shall be determined by contractor preference, permit requirements and/or as specific site conditions require.
- Contractor shall supply and install detectable pull tape in every underground conduit and have continuity end to end. The contractor shall provide and install weatherproof UR connectors to splice detectable wire as needed and splice pull tapes to allow no strain on

wire splice while retaining tape pulling strength. Stack must be left at access points so locators can attach to detectable wire.

08. Conduit, Under Roadway or commercial Driveway, 2-Inch:

- Contractor shall provide all material and equipment.
- Contractor shall connect to existing conduits, junction boxes, poles, etc.
- Installation method will typically be done by boring or as allowed by permit
- This item will be measured from junction box to junction box or ten (10) feet behind the curb whichever distance is shorter.

09. Traffic Bearing Junction Box w/Lid:

- Contractor shall provide all material and equipment.
- Installations shall be in soil or concrete
- Junction boxes installed shall have a 9-inch dry well of #57 aggregate, installed under the junction box to prevent standing water.
- Box/Lid shall be Tier 22-17 inch x 30 inch PD stackable, Open bottom w/mouse-holes. Equivalent to Quazite PD 1730-BB26 Box & PG 1730-HH00 Lid.

10. Install Fiber Optic Cable:

- LFUCG shall provide Fiber Optic Cable, Markers, and Sno-Shoes for aerial runs.
- Installations shall include vertical, Horizontal, in conduit, etc.
- Contractor shall witness testing of fiber before taking possession and replace fiber (at his/her cost) if damaged while in his possession.
- Billing shall be on a single cable (regardless of number of strands), per foot basis.
- Slack loops as determined by FLUCG shall be incidental, accounted for in the total footage.
- Lashing of aerial runs and detectible pull-string for underground runs shall be incidental to installation
- LFUCG shall terminate/splice fiber-optic cable installed.
- Corning Standard Recommended Procedure Guides shall be followed, particularly SRP 005-010 & 011.

11. Fiber Optic Cable:

- Contractor shall provide and install, 72-count, Loose Tube Type, Single Mode, Fiber Optic Cable. Mfg. Corning Altos #72-EU4-T4701D20 (No Substitutes)
- Installations shall include vertical, Horizontal, in conduit, etc.
- Contractor shall witness testing of fiber before taking possession and replace fiber (at his/her cost) if damaged while in his possession.
- Billing shall be on a single cable (regardless of number of strands), per foot basis.
- Slack loops as determined by FLUCG shall be incidental, accounted for in the total footage.
- Lashing of aerial runs and detectible pull-string for underground runs shall be incidental to installation
- LFUCG shall terminate/splice fiber-optic cable installed.
- Corning Standard Recommended Procedure Guides shall be followed, particularly SRP 005-010 & 011.
- All cable jacket footage numbers in and out of slack locations and at splice points shall be recorded and sent to LFUCG

12. Fusion Splicing of fiber-optic cable (Aerial or Underground installation):

- Contractor shall provide all materials and equipment needed to perform task to industry

standard and LFUCG specifications.

- LFUCG shall provide color codes, splice charts and splice cases, as needed
- Contractor shall provide documentation showing each splice meets industry standard.
- Each splice shall maintain maximum operable level for 30-days after being put in use.
- Bid quote shall be on a per twelve (12) splice basis.
- Contractor will be required to test fiber from points of termination to verify connections, when possible. Record and submit results to LFUCG Traffic Engineering OSP Network Supervisor for review.

13. Pole Attachment:

- Contractor shall provide and install all pole line hardware
- ¼-inch Strand Vines
- "D" Lashing Clamps
- Jumper Clamp, N/S Electric M EM 0800, - A grounding jumper clamp shall be installed at each wood pole attachment with an available ground wire
- Fiber Spacers – Fiber spacers shall be used at each location where fiber support messenger is attached to wood/steel poles.
- 1/2" galvanized Bolts, Square Washers and Nuts
- 3 bolt straight or curved suspension clamps, depending on location needs. Equivalent to Joslyn MSI H-J25088.1 and MSI H-J7901

14. Drop to Cabinet (Pathway):

- Contractor shall provide all material and equipment needed to perform task to industry standard and LFUCG specifications
- Includes providing and installing up to 200 feet of corrugated, inner-duct from designated splice point or junction box into the controller cabinet.
- Corrugated inner-duct is to be continuous, 1" ID, HDPE, Black w/UV protection and a 500 lb pulling tape pre-installed inside the duct. Equivalent to Dura Line P/N:2001005710.
- Incidental to this item will be lashing the inner-duct to the messenger cable and tapping up to two (2) steel strain poles

15. Demolish Existing Cable:

- Contractor shall provide all material and equipment needed to perform task
- The item id for overhead or underground demolition of the fiber-optic cable, and misc. components.
- Span wire and attachment hardware demolition shall be incidental to this item
- Bid quote shall be per five-hundred (500) feet.

16. Rock Removal (trench):

- Contractor must notify inspector when substantial rock is encountered within the designated path.
- Written approval will be given to the contractor to proceed through the rock once other options are ruled out.
- Quantity of material must be verified by the engineer or inspector before payment can be made.
- This unit shall also be used for roadway crossings requiring an open trench through asphalt and concrete.
- Pay unit for this item is cubic yard (CY).

17. Solid Rock Bore:

- Contractor must notify the inspector when solid rock is encountered within the designated path.
 - Solid rock is defined as any rock/surface that significantly slows the boring progress. Small, random obstructions will be considered incidental and not covered by this bid item.
 - The inspector must be present while the contractor is boring through rock in order to document the pay units.
 - Pay unit for this item is per linear foot (FT)
18. One Extra Conduit Underground/Under Roadway
- Contractor shall provide all materials and equipment.
 - Parallel conduit meeting all conduit specifications except for Color.
 - Intent is for this to be a spare conduit laid in the same trench or pulled through the same bore hole.
 - Installation method shall be determined by contractor preference, permit requirements and/or as specific site conditions require.
 - Pay unit for this item is per linear foot (FT)
19. Two Extra Conduits Underground/Under Roadway
- Contractor shall provide all materials and equipment.
 - Parallel conduits meeting all conduit specifications except for Color.
 - Intent is for this to be spare conduits laid in the same trench or pulled through the same bore hole.
 - Installation method shall be determined by contractor preference, permit requirements and/or as specific site conditions require.
 - Pay unit for this item is per linear foot (FT)
20. Pole Transfer on a Steel Pole
- Contractor shall provide all materials and equipment.
 - Installation method shall be determined by contractor preference, permit requirements and/or as specific site conditions require.
 - LFUCG will supply the parts to complete if new hardware is needed to complete transfer
 - Pay unit for each transfer (EA)
21. Pole Transfer on a Wooden Pole
- Contractor shall provide all materials and equipment.
 - Installation method shall be determined by contractor preference, permit requirements and/or as specific site conditions require.
 - LFUCG will supply the parts to complete if new hardware is needed to complete transfer
 - Pay unit for each transfer (EA)
22. Install Traffic Observation Camera
- Contractor shall provide all equipment and tools to install and route Ethernet cable to connection point within 100 Meters.
 - LFUCG will provide assemble and configure camera.
 - LFUCG will provide mount, pre-connectorized Ethernet cable and POE.
 - Cameras to be installed, positioned and connected per LFUCG's instructions.

23. Install wireless units and remote antennas for Cellular modems

- Contractor shall provide all equipment and tools to install and route cable to connection points within 100 Meters.
- LFUCG shall provide and configure units as required.
- LFUCG shall provide mount, pre-connectorized cables, POE's or power supplies.
- Units to be installed, positioned and connected per LFUCG's instructions.

Price Quotes:

Due to heavy volumes of traffic at certain intersections during regular working hours some scheduled work will take place after 6:00 pm.

The following bid quotes are for work done that is NON-EMERGENCY. Non-Emergency is scheduled work conducted by the contractor and/or project agreements between the contractor and the LFUCG.

YOU CAN USE THE BELOW TABLE FOR INFORMATIONAL PURPOSES, BUT PLEASE ENTER YOUR PRICING INFORMATION UNDER THE LINE ITEMS TAB IN IONWAVE.

Bid # 11-2024 Fiber-Optic Cable Installation & Repair					
Item #	Item Description	Unit	Bid per Unit	Estimated Work	Total
	Standard Installation and Repairs		A	B	= A X B
1	Wood Pole, 35-foot, Class 4	EA		4	
2	Wood Pole, 45-foot, Class 4	EA		4	
3	Down Guy (Standard)	EA		6	
4	Down Guy (Sidewalk)	EA		3	
5	Span Wire (Messenger Cable)	FT		12,500	
6	Conduit, Above Ground, Rigid Steel, 2-inch	FT		400	
7	Conduit, Underground, Non-Traffic Bearing Surface, 2-inch	FT		12,000	
8	Conduit, Under Roadway or Commercial Driveway, 2-inch	FT		400	
9	Traffic Bearing Junction Box w/Lid	EA		20	
10	Install Fiber-Optic Cable	FT		13,000	
11	Fiber Optic Cable	FT		13,000	
12	Fusion Splicing of fiber-optic cable (Aerial or Underground installation), (per 12 Splices)	EA		6	
13	Pole Attachment	EA		20	
14	Drop to Cabinet (Pathway)	EA		16	
15	Demolish Existing Cable (per 500 feet)	EA		4	

16	Rock Removal (trench)	CY		10	
17	Solid Rock Bore	FT		40	
18	One Extra Conduit Underground/Under Roadway	FT		8,000	
19	Two Extra Conduits Underground/Under Roadway	FT		2,000	
20	Pole Transfer – Steel Pole	EA		10	
21	Pole Transfer – Wooden Pole	EA		10	
22	Install Traffic Observation Camera	EA		15	
23	Install Wireless Units	EA		10	
	TOTAL				

There is no guarantee of amount of work to be awarded over the course of the contract.