



<b>LEXINGTON-FAYETTE URBAN COUNTY GOVERNMENT</b> <b>CONTRACT CHANGE ORDER</b> Page 1 of 2	Date:	December 7, 2015
	Project:	Masterson Station Park Restroom Building
	Location:	200 Ruffian Way
To (Contractor): Schaefer Contracting, LLC 1068 Macland Rd Lawrenceburg, KY 40342	Contract No.	151-2015
	Original Contract Amt.	\$169,999.00
	Cumulative Amount of Previous Change Orders	\$18,852.00
	Percent Change - Previous Change Orders	11.09%
	Total Contract Amount Prior to this Change Order	\$188,851.00
	Change Order No.	4

You are hereby requested to comply with the following changes from the contract plans and specification;

**Current Change Order**

Item No.	Description of changes-quantities, unit prices, change in completion date, etc.	Decrease in contract price	Increase in contract price
1	Electrical panel and transformer pad	\$0.00	\$24,550.00
2	Extend construction schedule - 28 calendar days	\$0.00	\$0.00
3	Plumbing fix	\$0.00	\$2,170.00
	Total decrease	\$0.00	
	Total increase		\$26,720.00
	Net Amount of this Change Order	\$26,720.00	
	New Contract Amount Including this Change Order	\$215,571.00	
	Percent Change - This Change Order		15.72%
	Percent Change - All Change Orders		26.81%

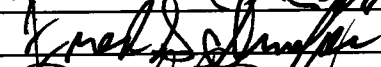
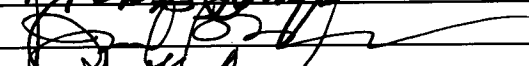
The time provided for the completion in the contract and all provisions of the contract will apply hereto.

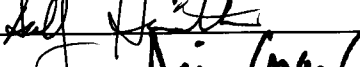
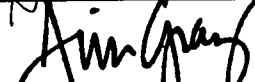
Recommended by - Jessica Walker		(Proj. Mgr.)	Date	12/9/15
Accepted by		(Contractor)	Date	12/8/15
Approved by		(Director)	Date	12-8-15
Approved by		(Commissioner)	Date	
Approved by		(Mayor or CAO)	Date	12/8/15
		Mayor		16-Dec-15

**JUSTIFICATION FOR CHANGE**

PROJECT: Masterson Station Park Restroom Building

CONTRACT NO. 151-2015

CHANGE ORDER: 4

1. Necessity for change: Add precast transformer pad and a 400Amp self-contained meter base and cabinet inside a free standing enclosure with lock, conduit and wire as described for \$24,550.00. Extend the construction schedule by 28 calendar days. Plumbing fix to accommodate wall hung toilet for \$2,170.00.
  
2. Is proposed change an alternate bid? \_\_\_ Yes  X  No
3. Will proposed change alter the physical size of the project? \_\_\_ Yes  X  No  
If "Yes", explain.
  
4. Effect of this change on other prime contractors: N/A
  
5. Has consent of surety been obtained? \_\_\_ Yes  X  Not Necessary
6. Will this change affect expiration or extent of insurance coverage? \_\_\_ Yes  X  No  
If "Yes", will the policies be extended? \_\_\_ Yes \_\_\_ No
7. Effect on operation and maintenance costs: N/A
  
8. Effect on contract completion date: additional 28 calendar days to schedule

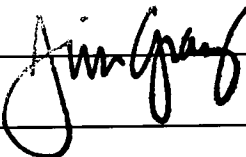
  
 \_\_\_\_\_ Mayor

16-Dec-15  
 \_\_\_\_\_ Date



- Owner
- Architect
- Contractor
- Field
- Other

# CHANGE ORDER

**Project:** Masterson Station Park Restroom Building

**Change Order Number:** 4

**To:** Schaefer Contracting, LLC  
1068 Macland  
Lawrenceburg, KY 40342

**Initiation Date:** 12/08/2015  
**File Number:** 201505  
**Contract For:**  
**Contract Date:** 07/06/2015

**You are directed to make the following changes in the contract:**

- 52x40 precast concrete pad for a single phase pad mounted transformer.
- 400A self-contained meter base and cabinet. Meter base to be mounted to the back side of the C&I free standing enclosure. Conduit to the meter base shall be GRC where subject to damage.
- 60"Wx72"Hx24"D C&I free standing enclosure with lock. The C&I enclosure will contain a 400A NEMA breaker enclosure. A 400A two-pole breaker. A 400A 120/240volt single phase 42 CKT Panelboard (NEMA1.) Panel includes the following breakers: (1) 150A two-pole, (5) 100A two-pole, (6) 60A two-pole. Also, (5) spare 1-1/2" PVC conduits that are to be turned out five feet. Price includes pouring one 8'x8'x6" concrete pad for the enclosure. Transformer, primary cable and conduit by others. Contractor to provide and install conduit and wire on the load side only. All conduit to be PVC, all conductors copper, no rock removal. All materials can be delivered in seven business days, with labor completed three weeks following. \$24,550...Twenty four thousand, five hundred fifty dollars.
- Proposed plumbing change requested by Tim Wilson. Cost to jackhammer floor, re-plumb women's side, exchange floor mounted toilet for wall hung. \$2,170...Two thousand, one hundred seventy dollars.  
Labor and materials for this item=

The work covered by this change order shall be performed under the same terms and conditions as that included in the original contract.

Not valid until signed by both the Owner and The Architect.

Signature of the Contractor indicates hid agreement herewith, including any adjustments in the Contract or contract Time.

The original (Contract Sum) (Guaranteed Maximum Cost) was.....	\$ 169,999.00
Net change by previous authorized Change Orders.....	\$ 18,852.00
The original (Contract Sum) (Guaranteed Maximum Cost) prior to this Change Order was.....	\$188,851.00
The original (Contract Sum) (Guaranteed Maximum Cost) will by (increased) (decreased) (unchanged) by this change order.....	\$ 26,720.00
The New (Contract Sum) (Guaranteed Maximum Cost) including this Change Order will be.....	\$215,571.00

The Contract time will be (increased) (decrease) (unchanged) by Twenty-eight (28) days

The Date of Substantial completion as of the date of this Change Order therefore is 12/29/2015

**Authorized:**

**Architect:**  
Kesler Simpson Architects, LLC  
3728 Willow Ridge Road  
Lexington, Kentucky 40514  
Date: 12-8-15

**Contractor:**

Date: 12/8/15

**Owner:**

Date: 12/8/15

# CONTRACT CHANGE ORDER

NO. 4
----------

FROM: Schaefer Contracting, LLC 1068 Macland Lawrenceburg, KY 40342
--

TO: JT Hulan KSA Architects
--------------------------------

DATE: 12-7-2015
JOB: MSPR
CONTRACT JOB NO.: REVISED Electrical change order
PREPARED BY:
WORK TO BEGIN BY:
WORK TO BE COMPLETED BY:

As requested during progress meeting on 12/3/15 Revised electrical change order proposal.

(1) 52x40 precast concrete pad for a single phase pad mounted transformer.

(1) 400a self contained meter base and cabinet. Meter base to be mounted to the back side of the C&I free standing enclosure. Conduit to the meter base shall be GRC where subject to damage.

(1) 60"x72" x24" C&I free standing enclosure with lock. The C&I enclosure will contain a 400a NEMA breaker enclosure. (1) 400a two pole breaker. (1) 400a 120/240volt single phase 42 CKT Panelboard (NEMA1). Panel includes the following breakers; (1) 150a 2pole,(5)100a 2pole,(6) 60a 2pole. Also, (5) spare 1 1/2" PVC conduits that are to be turned out five feet. Price includes pouring one 8'x8'x6" concrete pad for the enclosure. Transformer , primary cable and conduit by others. Contractor to provide and install conduit and wire on the load side only. All conduit to be PVC,all conductors copper, no rock removal. All materials can be delivered in seven business days. with labor completed three weeks following. \$24,550 .....Twentyfour thousand five hundred fifty dollars.

Schaefer Contracting, LLC is requesting an additional four weeks be added to the completion schedule to accommodate this work. ~~We are requesting an additional one months worth of General Conditions be added to the schedule of values for extra work, generator expense, time delays during the permit process, and late finance charges incurred. Requesting the amount of (\$2,350) Two thousand three hundred fifty dollars be added to the contract.~~

Proposed plumbing change requested by Tom Wilson. Cost to jackhammer floor re plumb womens side exchange floor mounted toilet for wall hung . Labor and material this item \$2,170.

~~Previously proposed change order to make sewer connection and install water line for \$5,568.~~

The work covered by this order shall be performed under the same terms and conditions as that included in the original Contract.

**CHANGES APPROVED**

BY
BY

PREVIOUS CONTRACT AMOUNT	\$
AMOUNT OF THIS ORDER	\$
TOTAL CONTRACT AND EXTRAS	\$0.00

BY: \_\_\_\_\_

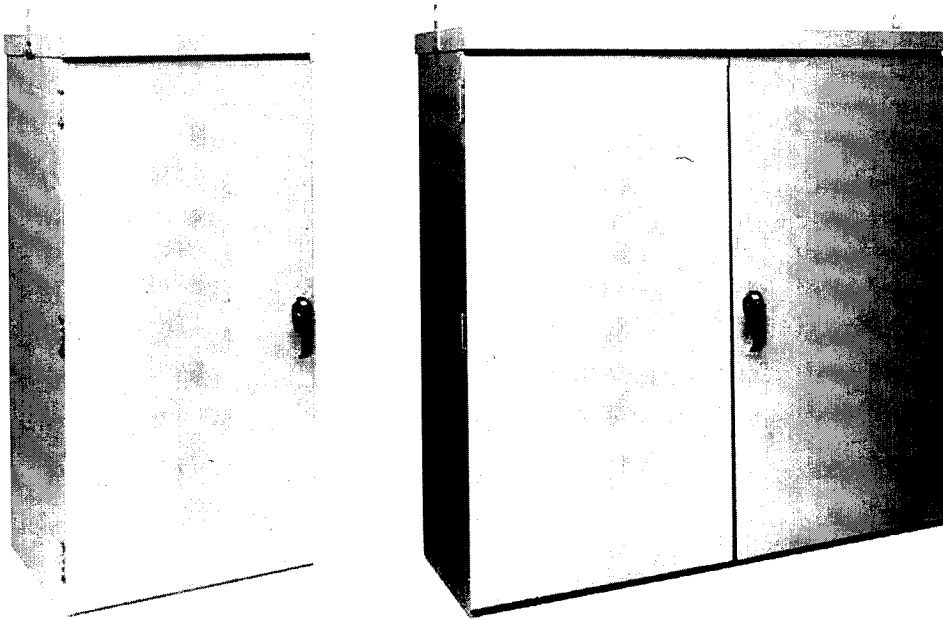

**INDUSTRY STANDARDS**

UL 508A Listed; Type 3R; File No. E61997  
 cUL/CSA C22.2 No. 94 Listed; Type 3R; File No. E61997

NEMA/EEMAC Type 3R  
 IEC 60529, IP32

**APPLICATION**

WEATHERPRO™ Outdoor Pad Mount Enclosures protect controls, drives, power distribution components or contactors in outdoor commercial or industrial power distribution and control applications. The overlapping two-door models with no center post allow full-width access to enclosure interior.

**FEATURES**

- 3-point latching system with heavy duty handle
- Padlock provision in handle
- Open bottom with pre-punched mounting hole flange
- Drip edge overhang on top
- Louvered overhang with a closure plate
- Studs included for mounting optional panels on threaded bolts
- Welded body construction
- Sturdy 7 gauge lifting tabs
- Overlapping doors with no center post on two-door models
- Bonding provision on each door
- Bolted hinges on doors

**SPECIFICATIONS**

- 14 gauge galvanized steel

**FINISH**

RAL 7035 light-gray polyester powder paint inside and outside. Optional panels are white.

**ACCESSORIES**

- See also Accessories.*
- Fan Shroud Kits
  - 19-in. Fixed Wall-Mount Rack
  - 19-in. Hinged Wall-Mount Panel
  - Insect Screens

**MODIFICATION AND CUSTOMIZATION**

Hoffman excels at modifying and customizing products to your specifications. Contact your local Hoffman sales office or distributor for complete information.

**BULLETIN: A3PM**

Standard Product WEATHERPRO Outdoor Pad-Mount Type 3R Two-Door Enclosures

A60R5218FSLP	60.00 x 52.00 x 18.00 1524 x 1321 x 457	A49P48N	49.16 x 48.00 1249 x 1219	4.90 x 20.90 124 x 531
A60R5224FSLP	60.00 x 52.00 x 24.00 1524 x 1321 x 610	A49P48N	49.16 x 48.00 1249 x 1219	7.90 x 20.90 201 x 531
A60R7224FSLP	60.00 x 72.00 x 24.00 1524 x 1829 x 610	A49P68N	49.16 x 68.00 1249 x 1727	7.90 x 30.90 201 x 785
A72R7218FSLP	72.00 x 72.00 x 18.00 1829 x 1829 x 457	A61P68N	61.16 x 68.00 1553 x 1727	4.90 x 30.90 124 x 785
A72R7224FSLP	72.00 x 72.00 x 24.00 1829 x 1829 x 610	A61P68N	61.16 x 68.00 1553 x 1727	7.90 x 30.90 201 x 785

Purchase panels separately.

Two-Door Enclosures

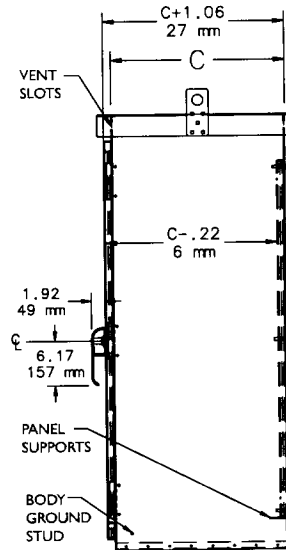
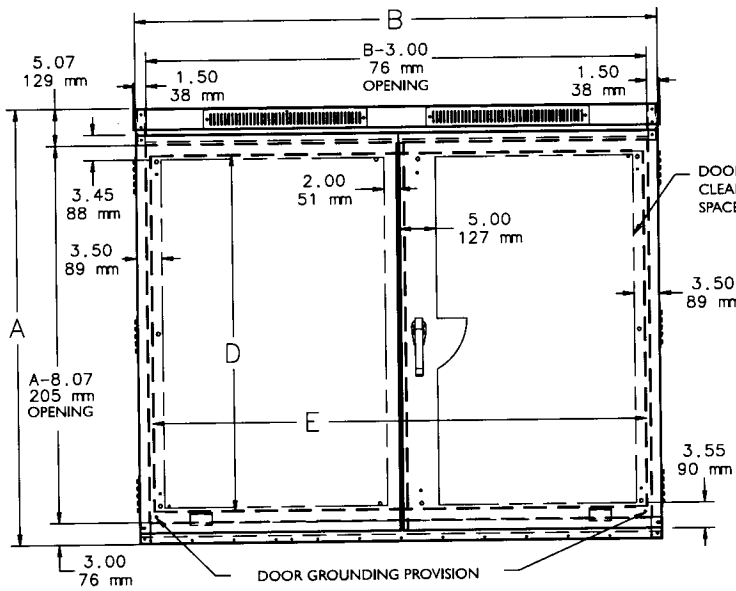
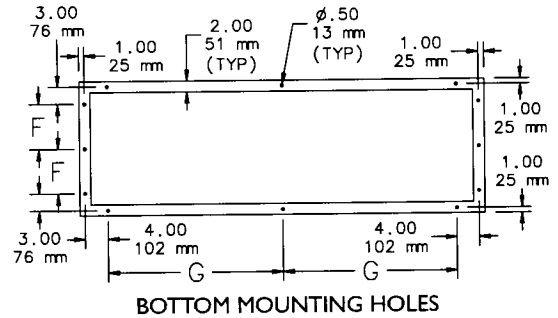
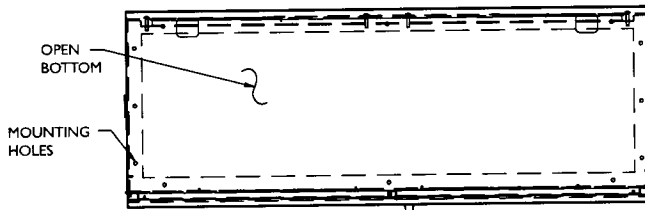

87789871

# CONCRETE PAD DETAIL

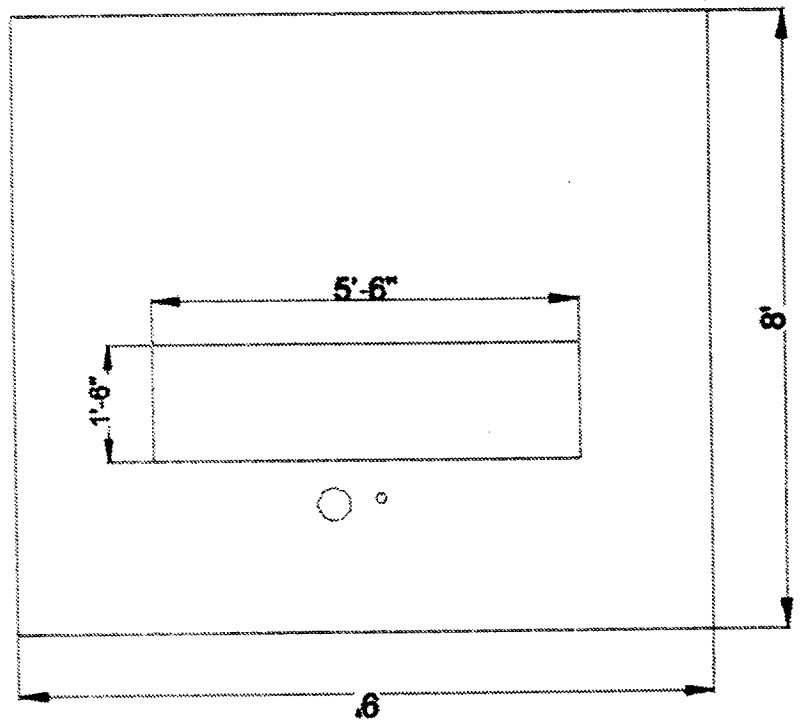

2 3/4" RIGID CONDUIT

1'-6"

4'-3"

2'-3"

4 INCHES OF PAD TO BE ABOVE GRADE





Lexington-Fayette Urban County Government  
DEPARTMENT OF GENERAL SERVICES

Jim Gray  
Mayor

Geoff Reed  
Commissioner

TO: Mayor Jim Gray  
Urban County Council

FROM:   
Geoff Reed, Commissioner, General Services

CC: Jamshid Baradaran, Director, Facilities and Fleet Management  
Jessica Walker, Administrative Officer, General Services  
Sandra Lopez, Administrative Officer, General Services

DATE: December 8, 2015

SUBJECT: Request a Resolution authorizing the Mayor, on behalf of the Urban County Government, to execute Change Order No. Four (4) to the Contract with Schaefer Contracting, LLC, for the Masterson Station Park Restroom Building Project, increasing the contract price by the sum of \$26,720.00 from \$188,851.00 to \$215,571.00 and twenty-eight (28) calendar days to the schedule.

---

**Request**

Authorization to Execute Change Order #4 with Schaefer Contracting, LLC in the amount of \$26,720.00 and an additional twenty-eight (28) calendar days to the schedule for the Masterson Station Park Restroom Building Contract #151-2015. The new contract amount including this change order is \$215,571.00.

**Why are you requesting?**

Add precast transformer pad and a 400Amp self-contained meter base and cabinet inside a free standing enclosure with lock, conduit and wire as described for \$24,550.00. Extend the construction schedule by 28 calendar days. Plumbing fix to accommodate wall hung toilet for \$2,170.00.

**What is the cost in this budget year and future budget years?**

The cost for this FY is: \$26,720.00

The cost for future FY is: N/A

The funds are budgeted in:

Account number:	FUND	DEPT ID	SECTION	ACCOUNT	SITE	BUDGET REF	AMOUNT
	1105	707602	7221	90319	764	2014	\$26,720.00

**File Number:** Schaefer Contracting, LLC Contract #151-2015

**Commissioner/Director:** Geoff Reed, Commissioner, General Services  
Jamshid Baradaran, Director, Facilities and Fleet Management