

Lexington-Fayette Urban County Government  
DEPARTMENT OF FINANCE & ADMINISTRATION

Jim Gray  
Mayor

William O'Mara  
Commissioner

**ADDENDUM #1**

Bid Number: **#161-2014**

Date: October 7, 2014

Address inquiries to:  
Kristie Thomas  
(859) 258-3320

Subject: Installation of Water Fountains at Shillito Park Sports Field

**TO ALL PROSPECTIVE SUBMITTERS:**

Please be advised of the following clarifications to the above referenced bid:

The pre-bid meeting is being rescheduled to 1:00 PM. Date and location remain the same.

Todd Slatin, Director  
Division of Central Purchasing

All other terms and conditions of the Bid and specifications are unchanged.  
This letter should be signed, attached to and become a part of your Bid.

COMPANY NAME: Angel Contracting LLC

ADDRESS: 1065 Highway 1383 Russell Springs, Ky. 42642

SIGNATURE OF BIDDER: Gina Martin-Johnson



Lexington-Fayette Urban County Government  
DEPARTMENT OF FINANCE & ADMINISTRATION

Jim Gray  
Mayor

William O'Mara  
Commissioner

**ADDENDUM #2**

Bid Number: 161-2014

Date: October 14, 2014

Subject: Installation of Water Fountains at Shillito Park Sports Field

Please address inquiries to:  
Kristie Thomas, Buyer  
(859) 258-3329

**TO ALL PROSPECTIVE BIDDERS:**

Please be advised of the following clarifications to the above referenced bid:

1. Pre-bid sign-in sheet attached.

\_\_\_\_\_  
Todd Slatin, Director  
Division of Central Purchasing

All other terms and conditions of the Bid and specifications are unchanged.  
This letter should be signed, attached to and become a part of your Bid.

COMPANY NAME: Angel Contracting, LLC  
ADDRESS: 1065 Highway 1383, Russell Springs, KY 42642  
SIGNATURE OF BIDDER: Risa Martin-James





# Lexington-Fayette Urban County Government

Lexington, Kentucky  
Horse Capital of the World

October 6 <sup>2014</sup>

Division of Central Purchasing

Date of Issue: September 11, 2014

## Request for Quotations, #Q25-2014 Installation of Water Fountains at Shillito Park Sports Field

<sup>BID</sup>  
Quotation Opening Date:  
Address:

<sup>161</sup>  
October 20, 2014  
September 25, 2014  
200 East Main Street, 3<sup>rd</sup> Floor, Room 338, Lexington, Kentucky 40507

<sup>BID</sup>  
Quotation Opening Time: **2:00 PM**  
(859) 258-3325

Pre Quote Meeting: N/A  
Address: N/A

Pre Quote Time: N/A

Sealed quotations will be received in the office of the Division of Central Purchasing, 200 East Main Street, Lexington, Kentucky, until **2:00 PM**, prevailing local time on **09/25/2014**. Quotations must be received by the above-mentioned date and time. All quotations must show the company name and address, Quotation Number and commodity/service on the outside of the envelope. Quotations may be mailed to:

<sup>10/20/2014</sup>  
Director, Division of Central Purchasing  
200 East Main Street, Room 338  
Lexington, KY 40507

<sup>161</sup>  
#Q25-2014, Installation of Water Fountains at Shillito Park Sports Field

Quotes are to include all shipping costs to the point of delivery located at: 300 West Reynolds Road, Lexington, KY 40503

See attached specifications pricing for item description(s).

<input checked="" type="checkbox"/> Bid Specifications Met	<b>Check One:</b> <input type="checkbox"/> Exceptions to Bid Specifications. <i>Exceptions shall be itemized and attached to bid proposal submitted.</i>	<b>Proposed Delivery:</b> _____ days after acceptance of bid.
<b>Procurement Card Usage</b> —The Lexington-Fayette Urban County Government may be using Procurement Cards to purchase goods and services and also to make payments. Will you accept Procurement Cards? _____ Yes _____ No		

Submitted by: Angel Contracting, LLC  
Firm Name

1065 Highway 1383  
Address

Russell Springs, KY 42642  
City, State & Zip

Heina Martin-Jones  
Representative's Name (Typed or printed)

859-368-0380      859-368-0382  
Area Code - Phone - Extension      Fax #

Scott.adams@angelcontracting.com  
E-Mail Address

**AFFIDAVIT**

Comes the Affiant, Lisa Martin Johnson, and after being first duly sworn under penalty of perjury as follows:

1. His/her name is Lisa Martin Johnson and he/she is the individual submitting the bid or is the authorized representative of Angel Contracting, LLC the entity submitting the bid (hereinafter referred to as "Bidder")
2. Bidder will pay all taxes and fees, which are owed to the Lexington-Fayette Urban County Government at the time the bid is submitted, prior to award of the contract and will maintain a "current" status in regard to those taxes and fees during the life of the contract.
3. Bidder will obtain a Lexington-Fayette Urban County Government business license, if applicable, prior to award of the contract.
4. Bidder has authorized the Division of Central Purchasing to verify the above-mentioned information with the Division of Revenue and to disclose to the Urban County Council that taxes and/or fees are delinquent or that a business license has not been obtained.
5. Bidder has not knowingly violated any provision of the campaign finance laws of the Commonwealth of Kentucky within the past five (5) years and the award of a contract to the Bidder will not violate any provision of the campaign finance laws of the Commonwealth.
6. Bidder has not knowingly violated any provision of Chapter 25 of the Lexington-Fayette Urban County Government Code of Ordinances, known as "Ethics Act."
7. Bidder acknowledges that "knowingly" for purposes of this Affidavit means, with respect to conduct or to circumstances described by a statute or ordinance defining an offense, that a person is aware or should have been aware that his conduct is of that nature or that the circumstance exists.

Further, Affiant sayeth naught. Lisa Martin Johnson

STATE OF Kentucky

COUNTY OF Fayette

The foregoing instrument was subscribed, sworn to and acknowledged before me by Lisa Martin Johnson on this the 20 day of October, 2014.

My Commission expires: Nov, 29<sup>th</sup> 2015  
[Signature]  
NOTARY PUBLIC, STATE AT LARGE

*Please refer to Section II. Bid Conditions, Item "U" prior to completing this form.*

## **I. GREEN PROCUREMENT**

### **A. ENERGY**

The Lexington-Fayette Urban County Government is committed to protecting our environment and being fiscally responsible to our citizens.

The Lexington-Fayette Urban County Government mandates the use of Energy Star compliant products if they are available in the marketplace (go to [www.Energystar.gov](http://www.Energystar.gov)). If these products are available, but not submitted in your pricing, your bid will be rejected as non-compliant.

ENERGY STAR is a government program that offers businesses and consumers energy-efficient solutions, making it easy to save money while protecting the environment for future generations.

#### Key Benefits

These products use 25 to 50% less energy  
Reduced energy costs without compromising quality or performance  
Reduced air pollution because fewer fossil fuels are burned  
Significant return on investment  
Extended product life and decreased maintenance

### **B. GREEN SEAL CERTIFIED PRODUCTS**

The Lexington-Fayette Urban County Government is also committed to using other environmentally friendly products that do not negatively impact our environment. Green Seal is a non-profit organization devoted to environmental standard setting, product certification, and public education.

Go to [www.Greenseal.org](http://www.Greenseal.org) to find available certified products. These products will have a reduced impact on the environment and on human health. The products to be used must be pre-approved by the LFUCG prior to commencement of any work in any LFUCG facility. If a Green Seal product is not available, the LFUCG must provide a signed waiver to use an alternate product. Please provide information on the Green Seal products being used with your bid response.

### **C. GREEN COMMUNITY**

**The Lexington-Fayette Urban County Government (LFUCG) serves as a principal, along with the University of Kentucky and Fayette County Public Schools, in the Bluegrass Partnership for a Green Community. The Purchasing Team component of the Partnership collaborates on economy of scale purchasing that promotes and enhances environmental initiatives. Specifically, when applicable, each principal is interested in obtaining best value products and/or services which promote environment initiatives via solicitations and awards from the other principals.**

**If your company is the successful bidder on this Invitation For Bid, do you agree to extend the same product/service pricing to the other principals of the Bluegrass Partnership for a Green Community (i.e. University of Kentucky and Fayette County Schools) if requested?**

Yes  No

## II. Bid Conditions

- A. No bid may be withdrawn for a period of sixty (60) days after the date and time set for opening.
- B. No bid may be altered after the date and time set for opening. In the case of obvious errors, the Division of Central Purchasing may permit the withdrawal of a bid. The decision as to whether a bid may be withdrawn shall be that of the Division of Central Purchasing.
- C. Acceptance of this proposal shall be enactment of an Ordinance by the Urban County Council.
- D. The bidder agrees that the Urban County Government reserves the right to reject any and all bids for either fiscal or technical reasons, and to award each part of the bid separately or all parts to one vendor.
- E. Minor exceptions may not eliminate the bidder. The decision as to whether any exception is minor shall be entirely that of the head of the requisitioning Department or Division and the Director of the Division of Central Purchasing. The Urban County Government may waive technicalities and informalities where such waiver would best serve the interests of the Urban County Government.
- F. Manufacturer's catalogue numbers, trade names, etc., where shown herein are for descriptive purposes and are to guide the bidder in interpreting the standard of quality, design, and performance desired, and shall not be construed to exclude proposals based on furnishing other types of materials and/or services. However, any substitution or departure proposed by the bidder must be clearly noted and described; otherwise, it will be assumed that the bidder intends to supply items specifically mentioned in this Invitation for Bids.
- G. The Urban County Government may require demonstrations of the materials proposed herein prior to acceptance of this proposal.
- H. Bids must be submitted on this form and must be signed by the bidder or his authorized representative. Unsigned bids will not be considered.
- I. Bids must be submitted prior to the date and time indicated for opening. Bids submitted after this time will not be considered.
- J. All bids mailed must be marked on the face of the envelope:

**"Bid on #161-2014 Installation of Water Fountains at Shillito Park Sports Field"**

and addressed to:            Division of Central Purchasing  
   200 East Main Street, Room 338  
   Lexington, Kentucky 40507

**The Lexington-Fayette Urban County Government assumes no responsibility for bids that are not addressed and delivered as indicated above. Bids that are not delivered to the Division of Central Purchasing by the stated time and date will be rejected.**

- K. Bidder is requested to show both unit prices and lot prices. In the event of error, the unit price shall prevail.
- L. A certified check or Bid Bond in the amount of XX percent of the bid price must be attached hereto. This check must be made payable to the Lexington-Fayette Urban County Government, and will be returned when the material and/or services specified herein have been delivered in accordance with specifications. In the event of failure to perform within the time period set forth in this bid, it is agreed the certified check may be cashed and the funds retained by the Lexington-Fayette Urban County Government as liquidated damages. Checks of unsuccessful bidders will be returned when the bid has been awarded.
- M. The delivery dates specified by bidder may be a factor in the determination of the successful bidder.
- N. Tabulations of bids received may be mailed to bidders. Bidders requesting tabulations must enclose a stamped, self-addressed envelope with the bid.
- O. The Lexington-Fayette Urban County Government is exempt from Kentucky Sales Tax and Federal Excise Tax on materials purchased from this bid invitation. Materials purchased by the bidder for construction projects are not tax exempt and are the sole responsibility of the bidder.
- P. All material furnished hereunder must be in full compliance with OSHA regulations.

- Q. If more than one bid is offered by one party, or by any person or persons representing a party, all such bids shall be rejected.
- R. Signature on the face of this bid by the Bidder or his authorized representative shall be construed as acceptance of and compliance with all terms and conditions contained herein.
- S. The Entity (regardless of whether construction contractor, non-construction contractor or supplier) agrees to provide equal opportunity in employment for all qualified persons, to prohibit discrimination in employment because of race, color, creed, national origin, sex or age, and to promote equal employment through a positive, continuing program from itself and each of its sub-contracting agents. This program of equal employment opportunity shall apply to every aspect of its employment policies and practices.
- T. The Kentucky Equal Employment Opportunity Act of 1978 (KRS 45.560-45.640) requires that any county, city, town, school district, water district, hospital district, or other political subdivision of the state shall include in directly or indirectly publicly funded contracts for supplies, materials, services, or equipment hereinafter entered into the following provisions:

During the performance of this contract, the contractor agrees as follows:

- (1) The contractor will not discriminate against any employee or applicant for employment because of race, color, religion, sex, age or national origin;*
- (2) The contractor will state in all solicitations or advertisements for employees placed by or on behalf of the contractors that all qualified applicants will receive consideration for employment without regard to race, color, religion, sex, age or national origin;*
- (3) The contractor will post notices in conspicuous places, available to employees and applicants for employment, setting forth the provisions of the non-discrimination clauses required by this section; and*
- (4) The contractor will send a notice to each labor union or representative of workers with which he has a collective bargaining agreement or other contract or understanding advising the labor union or workers' representative of the contractor's commitments under the nondiscrimination clauses.*

The Act further provides:

KRS 45.610. Hiring minorities - Information required

- (1) For the length of the contract, each contractor shall hire minorities from other sources within the drawing area, should the union with which he has collective bargaining agreements be unwilling to supply sufficient minorities to satisfy the agreed upon goals and timetable.*
- (2) Each contractor shall, for the length of the contract, furnish such information as required by KRS 45.560 to KRS 45.640 and by such rules, regulations and orders issued pursuant thereto and will permit access to all books and records pertaining to his employment practices and work sites by the contracting agency and the department for purposes of investigation to ascertain compliance with KRS 45.560 to 45.640 and such rules, regulations and orders issued pursuant thereto.*

KRS 45.620. Action against contractor - Hiring of minority contractor or subcontractor

- (1) If any contractor is found by the department to have engaged in an unlawful practice under this chapter during the course of performing under a contract or subcontract covered under KRS 45.560 to 45.640, the department shall so certify to the contracting agency and such certification shall be binding upon the contracting agency unless it is reversed in the course of judicial review.*
- (2) If the contractor is found to have committed an unlawful practice under KRS 45.560 to 45.640, the contracting agency may cancel or terminate the contract, conditioned upon a program for future compliance approved by the contracting agency and the department. The contracting agency may declare such a contractor ineligible to bid on further contracts with that agency until such time as the contractor complies in full with the requirements of KRS 45.560 to 45.640.*



- (3) *The equal employment provisions of KRS 45.560 to 45.640 may be met in part by a contractor by subcontracting to a minority contractor or subcontractor. For the provisions of KRS 45.560 to 45.640, a minority contractor or subcontractor shall mean a business that is owned and controlled by one or more persons disadvantaged by racial or ethnic circumstances.*

KRS 45.630 Termination of existing employee not required, when

*Any provision of KRS 45.560 to 45.640 notwithstanding, no contractor shall be required to terminate an existing employee upon proof that that employee was employed prior to the date of the contract.*

KRS 45.640 Minimum skills

*Nothing in KRS 45.560 to 45.640 shall require a contractor to hire anyone who fails to demonstrate the minimum skills required to perform a particular job.*

It is recommended that all of the provisions above quoted to be included as special conditions in each contract. In the case of a contract exceeding \$250,000, the contractor is required to furnish evidence that his work-force in Kentucky is representative of the available work-force in the area from which he draws employees, or to supply an Affirmative Action plan which will achieve such representation during the life of the contract.

- U. Any party, firm or individual submitting a proposal pursuant to this invitation must be in compliance with the requirements of the Lexington-Fayette Urban County Government regarding taxes and fees before they can be considered for award of this invitation and must maintain a "current" status with regard to those taxes and fees throughout the term of the contract. The contractor must be in compliance with Chapter 13 from the Code of Ordinances of the Lexington-Fayette Urban County Government. The contractor must be in compliance with Ordinance 35-2000 pursuant to contractor registration with the Division of Building Inspection. If applicable, said business must have a Fayette County business license.

Pursuant to KRS 45A.343 and KRS 45A.345, the contractor shall

- (1) *Reveal any final determination of a violation by the contractor within the previous five year period pursuant to KRS Chapters 136 (corporation and utility taxes), 139 (sales and use taxes), 141 (income taxes), 337 (wages and hours), 338 (occupational safety and health of employees), 341 (unemployment and compensation) and 342 (labor and human rights) that apply to the contractor; and*
- (2) *Be in continuous compliance with the above-mentioned KRS provisions that apply to the contractor for the duration of the contract.*

A contractor's failure to reveal the above or to comply with such provisions for the duration of the contract shall be grounds for cancellation of the contract and disqualification of the contractor from eligibility for future contracts for a period of two (2) years.

- V. Vendors who respond to this invitation have the right to file a notice of contention associated with the bid process or to file a notice of appeal of the recommendation made by the Director of Central Purchasing resulting from this invitation.

Notice of contention with the bid process must be filed within 3 business days of the bid/proposal opening by (1) sending a written notice, including sufficient documentation to support contention, to the Director of the Division of Central Purchasing or (2) submitting a written request for a meeting with the Director of Central Purchasing to explain his/her contention with the bid process. After consulting with the Commissioner of Finance the Chief Administrative Officer and reviewing the documentation and/or hearing the vendor, the Director of Central Purchasing shall promptly respond in writing findings as to the compliance with bid processes. If, based on this review, a bid process irregularity is deemed to have occurred the Director of Central Purchasing will consult with the Commissioner of Finance, the Chief Administrative Officer and the Department of Law as to the appropriate remedy.

Notice of appeal of a bid recommendation must be filed within 3 business days of the bid recommendation by (1) sending a written notice, including sufficient documentation to support appeal, to the Director, Division of Central Purchasing or (2) submitting a written request for a meeting with the Director of Central

Purchasing to explain his appeal. After reviewing the documentation and/or hearing the vendor and consulting with the Commissioner of Finance and the Chief Administrative Officer, the Director of Central Purchasing shall in writing, affirm or withdraw the recommendation.

## **LFUCG Non-Appropriation Clause**

Contractor acknowledges that the LFUCG is a governmental entity, and the contract validity is based upon the availability of public funding under the authority of its statutory mandate.

In the event that public funds are unavailable and not appropriated for the performance of the LFUCG's obligations under this contract, then this contract shall automatically expire without penalty to the LFUCG thirty (30) days after written notice to Contractor of the unavailability and non-appropriation of public funds. It is expressly agreed that the LFUCG shall not activate this non-appropriation provision for its convenience or to circumvent the requirements of this contract, but only as an emergency fiscal measure during a substantial fiscal crisis, which affects generally its governmental operations.

In the event of a change in the LFUCG's statutory authority, mandate and mandated functions, by state and federal legislative or regulatory action, which adversely affects the LFUCG's authority to continue its obligations under this contract, then this contract shall automatically terminate without penalty to the LFUCG upon written notice to Contractor of such limitation or change in the LFUCG's legal authority.

## **SPECIAL INSTRUCTIONS TO THE BIDDER**

### **(DO NOT SUBMIT PERFORMANCE SECURITY WITH BID)**

Performance Security: The APPARENT LOW BIDDER shall furnish, before recommendation by the Division of Central Purchasing to the Urban County Council that the BIDDER'S bid be accepted, a Performance Bond, Certified Check or Cashier's Check, payable to the Lexington-Fayette Urban County Government, in the penal sum of 100% of the price of the materials and/or services proposed in the bid.

The performance bond will not be returned to the bidder after delivery of the materials/services specified herein unless the bidder requests that the performance bond be returned.

The certified / cashier's check will be returned when the materials and/or services specified herein have been delivered.

In the event of bidder's failure to perform as specified herein, it is agreed that the monies represented by the performance bond or certified / cashier's check shall be retained by the Lexington-Fayette Urban County Government as liquidated damages.

Contracts that are less than \$50,000 will not require a 5% bid security or a performance and payment bond.

---

## **EQUAL OPPORTUNITY AGREEMENT**

The Law

- Title VII of the Civil Rights Act of 1964 (amended 1972) states that it is unlawful for an employer to discriminate in employment because of race, color, religion, sex, age (40-70 years) or national origin.
- Executive Order No. 11246 on Nondiscrimination under Federal contract prohibits employment discrimination by contractor and sub-contractor doing business with the Federal Government or recipients of Federal funds. This order was later amended by Executive Order No. 11375 to prohibit discrimination on the basis of sex.
- Section 503 of the Rehabilitation Act of 1973 states:

*The Contractor will not discriminate against any employee or applicant for employment because of physical or mental handicap.*

- Section 2012 of the Vietnam Era Veterans Readjustment Act of 1973 requires Affirmative Action on behalf of disabled veterans and veterans of the Vietnam Era by contractors having Federal contracts.
- Section 206(A) of Executive Order 12086, Consolidation of Contract Compliance Functions for Equal Employment Opportunity, states:

*The Secretary of Labor may investigate the employment practices of any Government contractor or sub-contractor to determine whether or not the contractual provisions specified in Section 202 of this order have been violated.*

The Lexington-Fayette Urban County Government practices Equal Opportunity in recruiting, hiring and promoting. It is the Government's intent to affirmatively provide employment opportunities for those individuals who have previously not been allowed to enter into the mainstream of society. Because of its importance to the local Government, this policy carries the full endorsement of the Mayor, Commissioners, Directors and all supervisory personnel. In following this commitment to Equal Employment Opportunity and because the Government is the benefactor of the Federal funds, it is both against the Urban County Government policy and illegal for the Government to let contracts to companies which knowingly or unknowingly practice discrimination in their employment practices. Violation of the above mentioned ordinances may cause a contract to be canceled and the contractors may be declared ineligible for future consideration.

Please sign this statement in the appropriate space acknowledging that you have read and understand the provisions contained herein. Return this document as part of your application packet.

Bidders

*I/We agree to comply with the Civil Rights Laws listed above that govern employment rights of minorities, women, Vietnam veterans, handicapped and aged persons.*

  
 \_\_\_\_\_  
 Signature

  
 \_\_\_\_\_  
 Name of Business

**GENERAL PROVISIONS OF BID CONTRACT**

By signing the below, bidder acknowledges that it understands and agrees with the following provisions related to its bid response and the provision of any goods or services to LFUCG upon selection by LFUCG pursuant to the bid request:

1. Bidder shall comply with all Federal, State & Local regulations concerning this type of service or good.
2. Failure to submit ALL forms and information required by LFUCG may be grounds for disqualification.
3. Addenda: All addenda, if any, must be considered by the bidder in making its response, and such addenda shall be made a part of the requirements of the bid contract. Before submitting a bid response, it is incumbent upon bidder to be informed as to whether any addenda have been issued, and the failure of the bidder to cover any such addenda may result in disqualification of that response.
4. Bid Reservations: LFUCG reserves the right to reject any or all bid responses, to award in whole or part, and to waive minor immaterial defects in proposals. LFUCG may consider any alternative proposal that meets its basic needs.
5. Liability: LFUCG is not responsible for any cost incurred by bidder in the preparation of its response.
6. Changes/Alterations: Bidder may change or withdraw a proposal at any time prior to the opening; however, no oral modifications will be allowed. Only letters, or other formal written requests for modifications or corrections of a previously submitted proposal which is addressed in the same manner as the bid response, and received by LFUCG prior to the scheduled closing time for receipt of bids, will be accepted. The bid response when opened, will then be corrected in accordance with such written request(s), provided that the written request is contained in a sealed envelope which is plainly marked "modifications of bid response".
7. Clarification of Submittal: LFUCG reserves the right to obtain clarification of any point in a bid or to obtain additional information from any bidder.
8. Bribery Clause: By his/her signature on its response, bidder certifies that no employee of his/hers, any affiliate or subcontractor, has bribed or attempted to bribe an officer or employee of the LFUCG.
9. Additional Information: While not necessary, the bidder may include any product brochures, software documentation, sample reports, or other documentation that may assist LFUCG in better understanding and evaluating the bid response. Additional documentation shall not serve as a substitute for other documentation which is required by the LFUCG to be submitted with the bid response.
10. Ambiguity, Conflict or other Errors: If a bidder discovers any ambiguity, conflict, discrepancy, omission or other error in the bid request of LFUCG, it shall immediately notify LFUCG of such error in writing and request modification or clarification of the document if allowable by the LFUCG.
11. Agreement to Bid Terms: In submitting its bid response, the bidder agrees that it has carefully examined the specifications and all provisions relating to LFUCG's bid request, including but not limited to the bid contract. By submission of its bid response, bidder states that it understands the meaning, intent and requirements of LFUCG's bid request and agrees to the same. The successful bidder shall warrant that it is familiar with and understands all provisions herein and shall warrant that it can comply with them. No additional compensation to bidder shall be authorized for services, expenses, or goods reasonably covered under these provisions that the bidder omits from its bid response.
12. Cancellation: LFUCG may unilaterally terminate the bid contract with the selected bidder(s) at any time, with or without cause, by providing at least thirty (30) days advance written notice unless a different advance written notice period is negotiated prior to contract approval. Payment for services or goods received prior to termination shall be made by the LFUCG provided these goods or services were provided in a manner acceptable to the LFUCG. Payment for those goods and services shall not be unreasonably withheld.
13. Assignment of Contract: The selected bidder(s) shall not assign or subcontract any portion of the bid contract with LFUCG without the express written consent of LFUCG. Any purported assignment or subcontract in violation hereof shall be void. It is expressly acknowledged that LFUCG shall never be required or obligated to consent to any request for assignment or subcontract; and further that such refusal to consent can be for any or no reason, fully within the sole discretion of LFUCG.

14. No Waiver: No failure or delay by LFUCG in exercising any right, remedy, power or privilege hereunder, nor any single or partial exercise thereof, nor the exercise of any other right, remedy, power or privilege shall operate as a waiver hereof or thereof. No failure or delay by LFUCG in exercising any right, remedy, power or privilege under or in respect of this bid proposal or bid contract shall affect the rights, remedies, powers or privileges of LFUCG hereunder or shall operate as a waiver thereof.
15. Authority to do Business: Each bidder must be authorized to do business under the laws of the Commonwealth of Kentucky and must be in good standing and have full legal capacity to provide the goods or services specified in the bid proposal. Each bidder must have all necessary right and lawful authority to submit the bid response and enter into the bid contract for the full term hereof including any necessary corporate or other action authorizing the bidder to submit the bid response and enter into this bid contract. If requested, the bidder will provide LFUCG with a copy of a corporate resolution authorizing this action and/or a letter from an attorney confirming that the proposer is authorized to do business in the Commonwealth of Kentucky. All bid responses must be signed by a duly authorized officer, agent or employee of the bidder.
16. Governing Law: This bid request and bid contract shall be governed by and construed in accordance with the laws of the Commonwealth of Kentucky. In the event of any proceedings regarding this matter, the bidder agrees that the venue shall be the Fayette County Circuit Court or the U.S. District Court for the Eastern District of Kentucky, Lexington Division and that the bidder expressly consents to personal jurisdiction and venue in such Court for the limited and sole purpose of proceedings relating to these matters or any rights or obligations arising thereunder.
17. Ability to Meet Obligations: Bidder affirmatively states that there are no actions, suits or proceedings of any kind pending against bidder or, to the knowledge of the bidder, threatened against the bidder before or by any court, governmental body or agency or other tribunal or authority which would, if adversely determined, have a materially adverse effect on the authority or ability of bidder to perform its obligations under this bid response or bid contract, or which question the legality, validity or enforceability hereof or thereof.
18. Bidder understands and agrees that its employees, agents, or subcontractors are not employees of LFUCG for any purpose whatsoever. Bidder is an independent contractor at all times related to the bid response or bid contract.
19. If any term or provision of this bid contract shall be found to be illegal or unenforceable, the remainder of the contract shall remain in full force and such term or provision shall be deemed stricken.

  
Signature

10-20-14  
Date

---

**WORKFORCE ANALYSIS FORM**

Name of Organization: Angel Contracting

Date: 10 / 20 / 14

Categories	Total	White		Latino		Black		Other		Total	
		M	F	M	F	M	F	M	F	M	F
Administrators	1		1								1
Professionals	1	1								1	
Superintendents	1	1								1	
Supervisors											
Foremen											
Technicians											
Protective Service											
Para-Professionals											
Office/Clerical											
Skilled Craft	2	2								2	
Service/Maintenance											
<b>Total:</b>	<b>5</b>	<b>4</b>	<b>1</b>							<b>4</b>	<b>1</b>

Prepared by: Risa Martin-Jones Owner  
Name & Title

**DIRECTOR, DIVISION OF CENTRAL PURCHASING  
 LEXINGTON-FAYETTE URBAN COUNTY GOVERNMENT  
 200 EAST MAIN STREET  
 LEXINGTON, KENTUCKY 40507**

**NOTICE OF REQUIREMENT FOR AFFIRMATIVE ACTION TO ENSURE  
EQUAL EMPLOYMENT OPPORTUNITIES AND DBE CONTRACT PARTICIPATION**

The Lexington-Fayette Urban County Government has set a goal that not less than ten percent (10%) of the total value of this contract be subcontracted to MBE/WBE's. The goal for the utilization of certified MBE/WBE's as subcontractors are recommended goals. Contractors who fail to meet such goals will be expected to provide written explanations to the Director of the Division of Central Purchasing of efforts they have made to accomplish the recommended goals and the extent to which they are successful in accomplishing the recommended goals will be a consideration in the procurement process.

For assistance in locating MBE/WBE Subcontractors contact Marilyn Clark at 859/258-3320 or by writing the address listed below:

Marilyn Clark, Division of Central Purchasing  
Lexington-Fayette Urban County Government  
200 East Main Street – Room 338  
Lexington, Kentucky 40507

**Lexington-Fayette Urban County Government**  
**MWDBE PARTICIPATION GOALS**

A. GENERAL

- 1) The LFUCG request all potential contractors to make a concerted effort to include Minority-Owned (MBE), Woman-Owned (WBE) and Disadvantaged (DBE) Business Enterprises as subcontractors or suppliers in their bids.
- 2) Toward that end, the LFUCG has established 10% of total procurement costs as a Goal for participation of Minority-Owned, Woman-Owned and Disadvantaged Businesses on this contract.
- 3) **It is therefore a request of each Bidder to include in its bid, the same goal (10%) for MWDBE participation and other requirements as outlined in this section.**

B. PROCEDURES

- 1) The successful bidder will be required to report to the LFUCG, the dollar amounts of all payments submitted to Minority-Owned or Woman-Owned subcontractors and suppliers for work done or materials purchased for this contract. (See Subcontractor Monthly Payment Report)
- 2) Replacement of a Minority-Owned or Woman-Owned subcontractor or supplier listed in the original submittal must be requested in writing and must be accompanied by documentation of Good Faith Efforts to replace the subcontractor / supplier with another MWDBE Firm; this is subject to approval by the LFUCG. (See LFUCG MWDBE Substitution Form)
- 3) For assistance in identifying qualified, certified businesses to solicit for potential contracting opportunities, bidders may contact:
  - a) The Lexington-Fayette Urban County Government, Division of Central Purchasing (859-258-3320)
- 4) The LFUCG will make every effort to notify interested MWDBE subcontractors and suppliers of each Bid Package, including information on the scope of work, the pre-bid meeting time and location, the bid date, and all other pertinent information regarding the project.

C. DEFINITIONS

- 1) A Minority-Owned Business Enterprise (MBE) is defined as a business which is certified as being at least 51% owned and operated by persons of African American, Hispanic, Asian, Pacific Islander, American Indian or Alaskan Native Heritage.
- 2) A Woman-Owned Business Enterprise (WBE) is defined as a business which is certified as being at least 51% owned and operated by one or more Non-Minority Females.
- 3) A Disadvantaged Business (DBE) is defined as a business which is certified as being at least 51% owned and operated by a person(s) that are economically and socially disadvantaged.
- 4) Good Faith Efforts are efforts that, given all relevant circumstances, a bidder or proposer actively and aggressively seeking to meet the goals, can reasonably be expected to make. In evaluating good faith efforts made toward achieving the goals, whether the bidder or proposer has performed the efforts outlined in the Obligations of Bidder for Good Faith Efforts outlined in this document will be considered, along with any other relevant factors.

D. OBLIGATION OF BIDDER FOR GOOD FAITH EFFORTS



- 1) **The bidder shall make a Good Faith Effort to achieve the Participation Goal for MWDBE subcontractors/suppliers. The failure to meet the goal shall not necessarily be cause for disqualification of the bidder; however, bidders not meeting the goal are required to furnish with their bids written documentation of their Good Faith Efforts to do so.**
- 2) Award of Contract shall be conditioned upon satisfaction of the requirements set forth herein.
- 3) The Form of Proposal includes a section entitled “MWDBE Participation Form”. The applicable information must be completed and submitted as outlined below.
- 4) **Failure to submit this information as requested may be cause for rejection of bid.**

E. DOCUMENTATION REQUIRED FOR GOOD FAITH EFFORTS

- 1) Bidders reaching the Goal are required to submit only the MWDBE Participation Form.” The form must be fully completed including names and telephone number of participating MWDBE firm(s); type of work to be performed; estimated value of the contract and value expressed as a percentage of the total Lump Sum Bid Price. The form must be signed and dated, and is to be submitted with the bid.
- 2) Bidders not reaching the Goal must submit the “MWDBE Participation Form”, the “Quote Summary Form” and a written statement documenting their Good Faith Effort to do so. If bid includes no MWDBE participation, bidder shall enter “None” on the subcontractor / supplier form). In addition, the bidder must submit written proof of their Good Faith Efforts to meet the Participation Goal:
  - a. Advertised opportunities to participate in the contract in at least two (2) publications of general circulation media; trade and professional association publications; small and minority business or trade publications; and publications or trades targeting minority, women and disadvantaged businesses not less than fifteen (15) days prior to the deadline for submission of bids to allow MWDBE firms to participate.
  - b. Included documentation of advertising in the above publications with the bidders good faith efforts package
  - c. Attended LFUCG Central Purchasing Economic Inclusion Outreach event
  - d. Attended pre-bid meetings that were scheduled by LFUCG to inform MWDBEs of subcontracting opportunities
  - e. Sponsored Economic Inclusion event to provide networking opportunities for prime contractors and MWDBE firms
  - f. Requested a list of MWDBE subcontractors or suppliers from LFUCG Economic Engine and showed evidence of contacting the companies on the list(s).
  - g. Contacted organizations that work with MWDBE companies for assistance in finding certified MWBDE firms to work on this project. Those contacted and their responses should be a part of the bidder’s good faith efforts documentation.

- h. Sent written notices, by certified mail, email or facsimile, to qualified, certified MWDBEs soliciting their participation in the contract not less than seven (7) days prior to the deadline for submission of bids to allow them to participate effectively.
- i. Followed up initial solicitations by contacting MWDBEs to determine their level of interest.
- j. Provided the interested MWDBE firm with adequate and timely information about the plans, specifications, and requirements of the contract.
- k. Selected portions of the work to be performed by MWDBE firms in order to increase the likelihood of meeting the contract goals. This includes, where appropriate, breaking out contract work items into economically feasible units to facilitate MWDBE participation, even when the prime contractor may otherwise perform these work items with its own workforce
- l. Negotiated in good faith with interested MWDBE firms not rejecting them as unqualified without sound reasons based on a thorough investigation of their capabilities. Any rejection should be so noted in writing with a description as to why an agreement could not be reached.
- m. Included documentation of quotations received from interested MWDBE firms which were not used due to uncompetitive pricing or were rejected as unacceptable and/or copies of responses from firms indicating that they would not be submitting a bid.
- n. Bidder has to submit sound reasons why the quotations were considered unacceptable. The fact that the bidder has the ability and/or desire to perform the contract work with its own forces will not be considered a sound reason for rejecting a MWDBE quote. Nothing in this provision shall be construed to require the bidder to accept unreasonable quotes in order to satisfy MWDBE goals.
- o. Made an effort to offer assistance to or refer interested MWDBE firms to obtain the necessary equipment, supplies, materials, insurance and/or bonding to satisfy the work requirements of the bid proposal
- p. Made efforts to expand the search for MWBE firms beyond the usual geographic boundaries.
- q. Other--any other evidence that the bidder submits which may show that the bidder has made reasonable good faith efforts to include MWDBE participation.

Failure to submit any of the documentation requested in this section may be cause for rejection of bid. Bidders may include any other documentation deemed relevant to this requirement. Documentation of Good Faith Efforts are to be submitted with the Bid, if the participation Goal is not met.



## MINORITY BUSINESS ENTERPRISE PROGRAM

Marilyn Clark  
Minority Business Enterprise Liaison  
Division of Central Purchasing  
Lexington-Fayette Urban County Government  
200 East Main Street  
Lexington, KY 40507  
[mclark@lexingtonky.gov](mailto:mclark@lexingtonky.gov)  
859-258-3323

OUR MISSION: The mission of the Minority Business Enterprise Program is to facilitate the full participation of minority and women owned businesses in the procurement process and to promote economic inclusion as a business imperative essential to the long term economic viability of Lexington-Fayette Urban County Government.

To that end the city council adopted and implemented resolution 167-91—Disadvantaged Business Enterprise (DBE) 10% Goal Plan in July of 1991. The resolution states in part (a full copy is available in Central Purchasing):

*“A Resolution supporting adoption of the administrative plan for a ten percent (10%) Minimum goal for disadvantaged business enterprise participation in Lexington-Fayette Urban County Government construction and professional services contracts; Providing that as part of their bids on LFUCG construction contracts, general Contractors shall make a good faith effort to award at least ten percent (10%) of All subcontracts to disadvantaged business enterprises; providing that divisions of LFUCG shall make a good faith effort to award at least ten percent of their Professional services and other contracts to disadvantaged business enterprises...”*

A Disadvantaged Business Enterprise is defined as a business that has been certified as being at least 51% owned, operated and managed by a U.S. Citizen of the following groups:

- African-American
- Hispanic-American
- Asian/Pacific Islander
- Native American/Native Alaskan
- Non-Minority Female
- Economically and Socially Disadvantaged

We have compiled the list below to help you locate certified MBE, WBE and DBE certified businesses. Below is a listing of contacts for LFUCG Certified MWDBEs in Economic Engine (<https://lfucg.economicengine.com>)

<b>Business</b>	<b>Contact</b>	<b>Email Address</b>	<b>Phone</b>
LFUCG	Marilyn Clark	<a href="mailto:mclark@lexingtonky.gov">mclark@lexingtonky.gov</a>	859-258-3323
Commerce Lexington – Minority Business Development	Tyrone Tyra	<a href="mailto:ttyra@commercelexington.com">ttyra@commercelexington.com</a>	859-226-1625
Tri-State Minority Supplier Diversity Council	Sonya Brown	<a href="mailto:sbrown@tsmsdc.com">sbrown@tsmsdc.com</a>	502-625-0137
Small Business Development Council	Dee Dee Harbut UK SBDC	<a href="mailto:ddharbut@uky.edu">ddharbut@uky.edu</a>	
	Shiree Mack	<a href="mailto:smack@uky.edu">smack@uky.edu</a>	
Community Ventures Corporation	James Coles	<a href="mailto:jcoles@cycky.org">jcoles@cycky.org</a>	859-231-0054
KY Department of Transportation	Melvin Bynes	<a href="mailto:Melvin.bynes@ky.gov">Melvin.bynes@ky.gov</a>	502-564-3601
	Shella Eagle	<a href="mailto:Shella.Eagle@ky.gov">Shella.Eagle@ky.gov</a>	502-564-3601
Ohio River Valley Women's Business Council (WBENC)	Rea Waldon	<a href="mailto:rwaldon@gcul.org">rwaldon@gcul.org</a>	513-487-6534
Kentucky MWBE Certification Program	Yvette Smith, Ken Finance Cabin	<a href="mailto:Yvette.Smith@ky.gov">Yvette.Smith@ky.gov</a>	502-564-8099
National Women Business Owner's Council (NWBOC)	Janet Harris-Lange	<a href="mailto:janet@nwbo.org">janet@nwbo.org</a>	800-675-5066
Small Business Administration	Robert Coffey	<a href="mailto:robertcoffey@sba.gov">robertcoffey@sba.gov</a>	502-582-5971
LaVoz de Kentucky	Andres Cruz	<a href="mailto:lavozdcky@yahoo.com">lavozdcky@yahoo.com</a>	859-621-2106
The Key News Journal	Patrice Muhammad	<a href="mailto:paatricem@keynewsjournal.com">paatricem@keynewsjournal.com</a>	859-373-9428



**LFUCG MWDBE PARTICIPATION FORM**  
**Bid/RFP/Quote Reference #161-2014**

The MWDBE subcontractors listed have agreed to participate on this Bid/RFP/Quote. If any substitution is made or the total value of the work is changed prior to or after the job is in progress, it is understood that those substitutions must be submitted to Central Purchasing for approval immediately.

MWDBE Company, Name, Address, Phone, Email	MBE WBE or DBE	Work to be Performed	Total Dollar Value of the Work	% Value of Total Contract
1. Walter Martin Exc. 501 Darby Creek Rd Suite 18 Lexington, KY 40509	WBE	Pave Fountain Pools	\$3,000. <sup>00</sup>	10.5%
2.				
3.				
4.				

The undersigned company representative submits the above list of MWDBE firms to be used in accomplishing the work contained in this Bid/RFP/Quote. Any misrepresentation may result in the termination of the contract and/or be subject to applicable Federal and State laws concerning false statements and false claims.

Angel Contracting, LLC.  
 Company

Heisa Martin-Jones  
 Company Representative

10-20-14  
 Date

Owner  
 Title



**LFUCG MWDBE SUBSTITUTION FORM**  
**Bid/RFP/Quote Reference #161-2014**

The substituted MWDBE subcontractors listed below have agreed to participate on this Bid/RFP/Quote. These substitutions were made prior to or after the job was in progress. These substitutions were made for reasons stated below and are now being submitted to Central Purchasing for approval. By the authorized signature of a representative of our company, we understand that this information will be entered into our file for this project.

SUBSTITUTED MWDBE Company Name, Address, Phone, Email	MWDBE Formally Contracted/ Name, Address, Phone, Email	Work to Be Performed	Reason for the Substitution	Total Dollar Value of the Work	% Value of Total Contract
1.					
2.					
3.					
4.					

The undersigned acknowledges that any misrepresentation may result in termination of the contract and/or be subject to applicable Federal and State laws concerning false statements and false claims.

\_\_\_\_\_  
**Company**

\_\_\_\_\_  
**Company Representative**

\_\_\_\_\_  
**Date**

\_\_\_\_\_  
**Title**



**MWDBE QUOTE SUMMARY FORM**

Bid/RFP/Quote Reference #161-2014

The undersigned acknowledges that the minority subcontractors listed on this form did submit a quote to participate on this project.

Company Name <i>Angel Contracting, LLC</i>	Contact Person <i>Christopher Scott Adams</i>
Address/Phone/Email <i>1065 Hwy 1383, Russell Springs, KY 42642 859-368-0380 Scott.adams@angelcontracting.com</i>	Bid Package / Bid Date <i>161-2014</i>

MWDBE Company Address	Contact Person	Contact Information (work phone, Email, cell)	Date Contacted	Services to be performed	Method of Communication (email, phone meeting, ad, event etc)	Total dollars \$\$ Do Not Leave Blank (Attach Documentation)	MBE * AA HA AS NA Female
<i>Walter Martin Ex. Sci. Dir. Fayette Urban County Government Lexington, KY 40509</i>	<i>Lisa Martin-Johnson</i>	<i>859-368-0380</i>	<i>10-7-14</i>	<i>Power Foundation Plant</i>	<i>Phone</i>	<i>3,000.00</i>	<i>WBE</i>

(MBE designation / AA=African American / HA= Hispanic American/AS = Asian American/Pacific Islander/ NA= Native American)

The undersigned acknowledges that all information is accurate. Any misrepresentation may result in termination of the contract and/or be subject to applicable Federal and State laws concerning false statements and claims.

*Angel Contracting, LLC*  
Company

*Lisa Martin-Johnson*  
Company Representative

*10-20-14*  
Date

*Owner*  
Title

**LFUCG STATEMENT OF GOOD FAITH EFFORTS**

**Bid/RFP/Quote #161-2014**

N/A

By the signature below of an authorized company representative, we certify that we have utilized the following Good Faith Efforts to obtain the maximum participation by MWDBE business enterprises on the project and can supply the appropriate documentation.

- Advertised opportunities to participate in the contract in at least two (2) publications of general circulation media; trade and professional association publications; small and minority business or trade publications; and publications or trades targeting minority, women and disadvantaged businesses not less than fifteen (15) days prior to the deadline for submission of bids to allow MWDBE firms to participate.
- Included documentation of advertising in the above publications with the bidders good faith efforts package
- Attended LFUCG Central Purchasing Economic Inclusion Outreach event
- Attended pre-bid meetings that were scheduled by LFUCG to inform MWDBEs of subcontracting opportunities
- Sponsored Economic Inclusion event to provide networking opportunities for prime contractors and MWDBE firms
- Requested a list of MWDBE subcontractors or suppliers from LFUCG Economic Engine and showed evidence of contacting the companies on the list(s).
- Contacted organizations that work with MWDBE companies for assistance in finding certified MWBDE firms to work on this project. Those contacted and their responses should be a part of the bidder's good faith efforts documentation.
- Sent written notices, by certified mail, email or facsimile, to qualified, certified MWDBEs soliciting their participation in the contract not less that seven (7) days prior to the deadline for submission of bids to allow them to participate effectively.
- Followed up initial solicitations by contacting MWDBEs to determine their level of interest.
- Provided the interested MWBDE firm with adequate and timely information about the plans, specifications, and requirements of the contract.
- Selected portions of the work to be performed by MWDBE firms in order to increase the likelihood of meeting the contract goals. This includes, where appropriate, breaking out contract work items into economically feasible units to facilitate MWDBE participation, even when the prime contractor may otherwise perform these work items with its own workforce
- Negotiated in good faith with interested MWDBE firms not rejecting them as unqualified without sound reasons based on a thorough investigation of their capabilities. Any rejection should be so noted in writing with a description as to why an agreement could not be reached.



N/A

- Included documentation of quotations received from interested MWDBE firms which were not used due to uncompetitive pricing or were rejected as unacceptable and/or copies of responses from firms indicating that they would not be submitting a bid.
- Bidder has to submit sound reasons why the quotations were considered unacceptable. The fact that the bidder has the ability and/or desire to perform the contract work with its own forces will not be considered a sound reason for rejecting a MWDBE quote. Nothing in this provision shall be construed to require the bidder to accept unreasonable quotes in order to satisfy MWDBE goals.
- Made an effort to offer assistance to or refer interested MWDBE firms to obtain the necessary equipment, supplies, materials, insurance and/or bonding to satisfy the work requirements of the bid proposal
- Made efforts to expand the search for MWDBE firms beyond the usual geographic boundaries.
- Other - any other evidence that the bidder submits which may show that the bidder has made reasonable good faith efforts to include MWDBE participation.

Failure to submit any of the documentation requested in this section may be cause for rejection of bid. Bidders may include any other documentation deemed relevant to this requirement. Documentation of Good Faith Efforts are to be submitted with the Bid, if the participation Goal is not met.

The undersigned acknowledges that all information is accurate. Any misrepresentations may result in termination of the contract and/or be subject to applicable Federal and State laws concerning false statements and claims.

Angel Contracting, LLC  
Company

Risa Martin-Johnson  
Company Representative

10-20-14  
Date

Owner  
Title

## **RISK MANAGEMENT PROVISIONS**

### **INSURANCE AND INDEMNIFICATION**

---

#### **INDEMNIFICATION AND HOLD HARMLESS PROVISION**

- (1) It is understood and agreed by the parties that Contractor hereby assumes the entire responsibility and liability for any and all damages to persons or property caused by or resulting from or arising out of any act or omission on the part of Contractor or its employees, agents, servants, owners, principals, licensees, assigns or subcontractors of any tier (hereinafter "CONTRACTOR") under or in connection with this agreement and/or the provision of goods or services and the performance or failure to perform any work required thereby.
- (2) CONTRACTOR shall indemnify, save, hold harmless and defend the Lexington-Fayette Urban County Government and its elected and appointed officials, employees, agents, volunteers, and successors in interest (hereinafter "LFUCG") from and against all liability, damages, and losses, including but not limited to, demands, claims, obligations, causes of action, judgments, penalties, fines, liens, costs, expenses, interest, defense costs and reasonable attorney's fees that are in any way incidental to or connected with, or that arise or are alleged to have arisen, directly or indirectly, from or by CONTRACTOR's performance or breach of the agreement and/or the provision of goods or services provided that: (a) it is attributable to personal injury, bodily injury, sickness, or death, or to injury to or destruction of property (including the loss of use resulting therefrom), or to or from the negligent acts, errors or omissions or willful misconduct of the CONTRACTOR; and (b) not caused solely by the active negligence or willful misconduct of LFUCG.
- (3) In the event LFUCG is alleged to be liable based upon the above, CONTRACTOR shall defend such allegations and shall bear all costs, fees and expenses of such defense, including but not limited to, all reasonable attorneys' fees and expenses, court costs, and expert witness fees and expenses, using attorneys approved in writing by LFUCG, which approval shall not be unreasonably withheld.
- (4) These provisions shall in no way be limited by any financial responsibility or insurance requirements, and shall survive the termination of this agreement.
- (5) LFUCG is a political subdivision of the Commonwealth of Kentucky. CONTRACTOR acknowledges and agrees that LFUCG is unable to provide indemnity or otherwise save, hold harmless, or defend the CONTRACTOR in any manner.

#### **FINANCIAL RESPONSIBILITY**

BIDDER/CONTRACTOR understands and agrees that it shall, prior to final acceptance of its bid and the commencement of any work, demonstrate the ability to assure compliance with the above Indemnity provisions and these other risk management provisions.

#### **INSURANCE REQUIREMENTS**

YOUR ATTENTION IS DIRECTED TO THE INSURANCE REQUIREMENTS BELOW, AND YOU MAY NEED TO CONFER WITH YOUR INSURANCE AGENTS, BROKERS, OR CARRIERS TO DETERMINE IN ADVANCE OF SUBMISSION OF A RESPONSE THE AVAILABILITY OF THE INSURANCE COVERAGES AND ENDORSEMENTS REQUIRED HEREIN. IF YOU FAIL TO COMPLY WITH THE INSURANCE REQUIREMENTS BELOW, YOU MAY BE DISQUALIFIED FROM AWARD OF THE CONTRACT.

## Required Insurance Coverage

BIDDER/CONTRACTOR shall procure and maintain for the duration of this contract the following or equivalent insurance policies at no less than the limits shown below and cause its subcontractors to maintain similar insurance with limits acceptable to LFUCG in order to protect LFUCG against claims for injuries to persons or damages to property which may arise from or in connection with the performance of the work hereunder by CONTRACTOR. The cost of such insurance shall be included in any bid:

<u>Coverage</u>	<u>Limits</u>
General Liability (Insurance Services Office Form CG 00 01)	\$1 million per occurrence, \$2 million aggregate or \$2 million combined single limit
Commercial Automobile Liability (Insurance Services Office Form CA 0001)	combined single, \$1 million per occurrence
Worker's Compensation	Statutory
Employer's Liability	\$500,000.00

The policies above shall contain the following conditions:

- a. All Certificates of Insurance forms used by the insurance carrier shall be properly filed and approved by the Department of Insurance for the Commonwealth of Kentucky (DOI). LFUCG shall be named as an additional insured in the General Liability Policy and Commercial Automobile Liability Policy using the Kentucky DOI approved forms.
- b. The General Liability Policy shall be primary to any insurance or self-insurance retained by LFUCG.
- c. The General Liability Policy shall include a Products and Completed Operations endorsement or Premises and Operations Liability and a Products Liability endorsement unless it is deemed not to apply by LFUCG.
- d. LFUCG shall be provided at least 30 days advance written notice via certified mail, return receipt requested, in the event any of the required policies are canceled or non-renewed.
- e. Said coverage shall be written by insurers acceptable to LFUCG and shall be in a form acceptable to LFUCG. Insurance placed with insurers with a rating classification of no less than Excellent (A or A-) and a financial size category of no less than VIII, as defined by the most current Best's Key Rating Guide shall be deemed automatically acceptable.

## Renewals

After insurance has been approved by LFUCG, evidence of renewal of an expiring policy must be submitted to LFUCG, and may be submitted on a manually signed renewal endorsement form. If the policy or carrier has changed, however, new evidence of coverage must be submitted in accordance with these Insurance Requirements.

## Deductibles and Self-Insured Programs

### **IF YOU INTEND TO SUBMIT A SELF-INSURANCE PLAN IT MUST BE FORWARDED TO LEXINGTON-FAYETTE URBAN COUNTY GOVERNMENT, DIVISION OF RISK MANAGEMENT, 200 EAST MAIN STREET, LEXINGTON, KENTUCKY 40507 NO LATER THAN A MINIMUM OF FIVE (5) WORKING DAYS PRIOR TO THE RESPONSE DATE.**

Self-insurance programs, deductibles, and self-insured retentions in insurance policies are subject to separate approval by Lexington-Fayette Urban County Government's Division of Risk Management, upon review of evidence of BIDDER/CONTRACTOR's financial capacity to respond to claims. Any such programs or retentions must provide LFUCG with at least the same protection from liability and defense of suits as would be afforded by first-dollar insurance coverage. If BIDDER/CONTRACTOR satisfies any portion of the insurance requirements through deductibles, self-insurance programs, or self-insured retentions, BIDDER/CONTRACTOR agrees to provide Lexington-Fayette Urban County Government, Division of Risk Management, the following data prior to the final acceptance of bid and the commencement of any work:

- a. Latest audited financial statement, including auditor's notes.
- b. Any records of any self-insured trust fund plan or policy and related accounting statements.
- c. Actuarial funding reports or retained losses.
- d. Risk Management Manual or a description of the self-insurance and risk management program.
- e. A claim loss run summary for the previous five (5) years.
- f. Self-Insured Associations will be considered.

## Safety and Loss Control

CONTRACTOR shall comply with all applicable federal, state, and local safety standards related to the performance of its works or services under this Agreement and take necessary action to protect the life, health and safety and property of all of its personnel on the job site, the public, and LFUCG.

## Verification of Coverage

BIDDER/CONTRACTOR agrees to furnish LFUCG with all applicable Certificates of Insurance signed by a person authorized by the insurer to bind coverage on its behalf prior to final award, and if requested, shall provide LFUCG copies of all insurance policies, including all endorsements.

## Right to Review, Audit and Inspect

CONTRACTOR understands and agrees that LFUCG may review, audit and inspect any and all of its records and operations to insure compliance with these Insurance Requirements.

## **DEFAULT**

BIDDER/CONTRACTOR understands and agrees that the failure to comply with any of these insurance, safety, or loss control provisions shall constitute default and that LFUCG may elect at its option any single remedy or penalty or any combination of remedies and penalties, as available, including but not limited to purchasing insurance and charging BIDDER/CONTRACTOR for any such insurance premiums purchased, or suspending or terminating the work.

Lexington-Fayette Urban County Government  
Division of Parks and Recreation  
#161-2014 Installation of Water Fountains at Shillito Park Sports Field

**Scope of Work:**

- Installation of two (2) Murdock GYM54 (pedestal mounted drinking fountain with bottle filler, freeze resistant). **Fixtures to be provided by Owner.** All supply lines, valves, fittings miscellaneous parts/supplies needed for the installation, hardware, shut off valves, back-flow preventer, pressure regulator, drain lines, valve boxes, gravel, concrete pad and site restoration are to be provided by the Contractor . See diagram and Murdock installation instructions.

All valve boxes must be installed outside of and adjacent to the edge of the concrete supporting pad for the drinking fountain.

- Each fountain to have 3 cubic feet of #2 gravel beneath the concrete pad with a 50' X 4" perforated drain pipe embedded in gravel.

The ditch for the drain pipe shall measure two feet (2'-0") wide and a minimum of thirty six inches (36") deep. Place the four inch perforated drain pipe with sock on top of eighteen inches (18") of number two rock. Cover the drain pipe with an additional twelve inches (12") of number two rock. This amounts to a total combined depth of the twenty-eight inches (28") of rock in the two foot wide ditch.

- Install approximately 875' ft. of 2" schedule 40 PVC water line 30" deep (must be a dug line...trenching not permitted on this project) to the KAWC main located on Reynolds Rd. A new water meter will be installed by KAWC. Also provide two (2) tees and ¾" water line for each drinking fountain per site plan provided.

The main water line should be a minimum of two inches in diameter. The branch water lines for the drinking fountains should be a minimum of one inch diameter.

- Tracer wire to be installed with all new water lines back to the new water meter.

Tracer wire should be a minimum of twelve gauge wire. The wire should be taped to the water line at four foot intervals prior to the water line being placed into the ditch.

- Rock clause to be included as a unit price per cubic yard for mechanical removal and disposal.
- Backfill trenches for waterlines with clean soil backfill, sand or crushed stone. If large rocks are encountered when trenching do not place them back in water line trench as backfill.
- All backfill and damaged turf area to receive seed (fine lawn type fescue), fertilizer, and straw cover. Soil to be tilled/loosened prior to seeding.

- Fountain is to be mounted on 8' X 10' poured in place ready mix concrete pad. See diagram for detail. The concrete pad shall have 1%-2% slope down to the outer edges so water will not stand on the concrete surface.
- Parks and Recreation will locate any known underground utilities prior to construction. The contractor must provide our Project Manager at least 48 hours prior to digging.
- If rock is encountered the contractor should cease work immediately and contact Parks and Recreation Project Manager for an on-site consultation on whether to proceed with rock removal or consider relocation. Any work done without authorization shall not be considered for payment.

**Pricing:**

Lump sum for all materials, labor, and equipment to install water line and the drinking fountains (fixtures provided by Owner) per the specifications and diagram.

\$ 28,600.<sup>00</sup>

Provide unit price for cubic yard of rock removal and disposal. Rock is considered if it requires mechanical removal, i.e. hoe ram, jack hammer, etc. Loose rock that can be removed with a back hoe will not be considered on the unit price and shall be included in the lump sum.

\$ 750.<sup>00</sup> / cu.yd.

# Shillito Park

## New Fountains and water Lines

300 West Reynolds Rd.

September 2, 2014

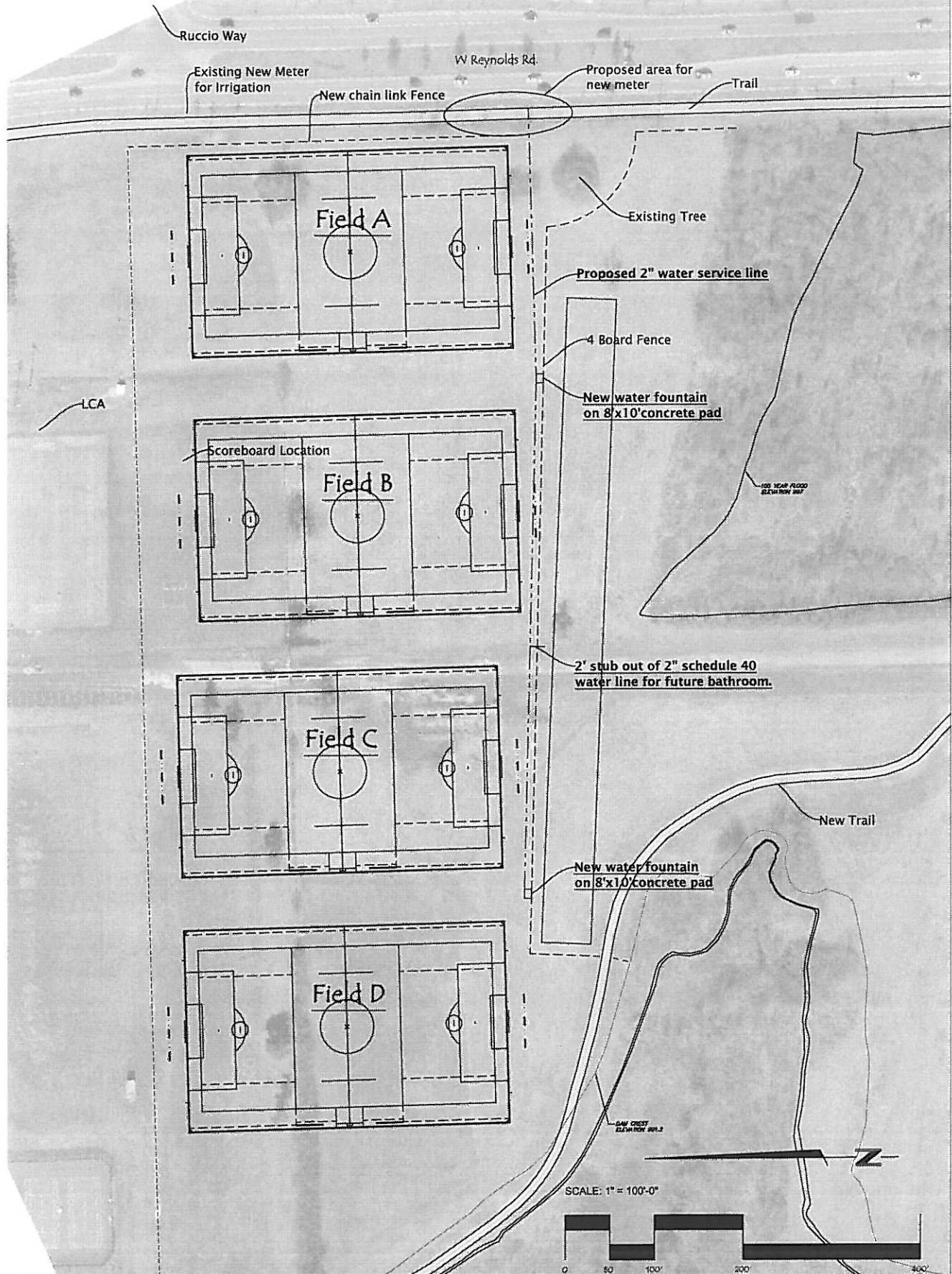

# Water Hydrant Valve Box

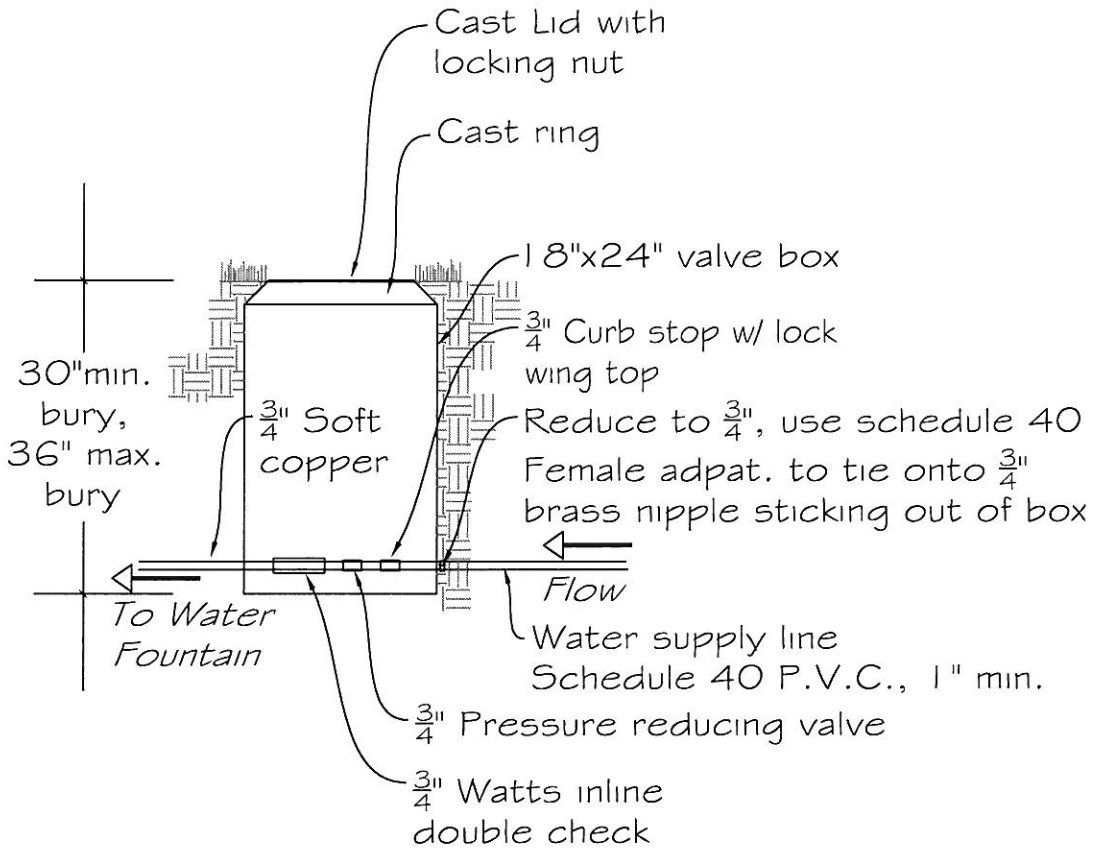

~ All valves and fittings to be brass unless otherwise noted.





# CONTEMPORARY DRINKING FOUNTAINS

## GY Series

**MODEL GYM54**  
PEDESTAL MOUNTED DRINKING  
FOUNTAIN WITH BOTTLE FILLER

### STANDARD FEATURES

- Adult ADA compliant for wheelchair users
- Pushbutton and hands free sensor operated Bottle filler
- Battery pack 6AA
- Laminar flow water supply to bottle filler
- Resistant to sunlight, heat, moisture and wear
- 18 Gage, 304 stainless steel drinking Fountain bowls
- 12 Gage, heavy duty stainless steel construction with corrosion and scratch resistant finish
- Stainless steel, anti-rotation non-squirt bubbler
- 100 mesh inlet strainer
- Access cover, heavy duty stainless steel, vandal resistant

### SUGGESTED SPECIFICATIONS

Barrier free drinking fountain with bottle filler shall be Murdock model GYM54. Construction shall be 12 gage, all stainless steel with 18 gage stainless steel fountain bowl. Pedestal base shall have four mounting holes. Access covers shall be secured with vandal-resistant stainless steel screws. Bottle filler shall be activated by a 9 volt sensor or a pushbutton as standard. Unit shall contain a 100 mesh inlet strainer, lead and cyst filter, 6-AA battery pack and laminar flow spout. Self-closing push-button, needing less than 5 pounds force, shall activate internally mounted valve with adjustable stream regulator. Bubbler shall be stainless steel with non-squirt feature and operate on water pressure range of 20-105 psig. Unit shall conform to ANSI A117.1, 2010 ADA Standards for Accessible Design, ANSI/NSF 61-9, CHSC 116875 and US Public Law 111-380.



Model GYM55 Shown

### MODELS:

- GYM54 Satin Stainless Finish
- GYM55 Green Powder-Coated
- GYM56 Red Powder-Coated
- GYM57 Blue Powder-Coated

### OPTIONAL ACCESSORIES

*(additional costs may be incurred)*

- FRU2 Underground freeze-resistant for two valves (Pushbutton operation only, Less filter) <sup>1</sup>
- FRU3 Underground freeze-resistant for three valves (Pushbutton operation only, Less filter) <sup>1</sup>
- HB1 Hose bibb with vacuum breaker <sup>1 2</sup>
- HB3 Vandal resistant hose bibb with vacuum breaker <sup>1 2</sup>
- IAP In-ground anchor plate <sup>1</sup>
- LOGO Customer specified logo <sup>1</sup>
- MO Bottle filler operated by pushbutton only (required for freeze-resistant valve)
- PF pet fountain with push-button valve <sup>1</sup>

#### Option Notes:

<sup>1</sup> See separate option sheet

<sup>2</sup> This option is not available freeze-resistant

Please visit [www.murdockmfg.com](http://www.murdockmfg.com) for most current specifications.



Member of  
U.S. Green  
Building  
Council



Recyclable  
Product



Water  
Conserving  
Product

Complies  
with the  
following  
standards:



Federal  
Public Law  
111-380  
11/18/05

**MURDOCK MFG.** • 15125 Proctor Avenue • City of Industry, CA 91746 USA  
Phone 800-453-7465 or 626-333-2543 • Fax 626-855-4860 • [www.murdockmfg.com](http://www.murdockmfg.com)

Member of  
MORRIS GROUP



# CONTEMPORARY DRINKING FOUNTAINS

All dimensions are subject to manufactures tolerance of plus or minus 1/2" nominal and subject to change without notice. Murdock Mfg. assumes no responsibility for use of void or superseded data. Dimensions may change with the addition of optional accessories. Murdock Mfg.™, Member of Morris Group International™. Please visit [www.Murdockmfg.com](http://www.Murdockmfg.com) for most current specifications.

## GY Series

### MODEL GYM54 PEDESTAL MOUNTED DRINKING FOUNTAIN WITH BOTTLE FILLER

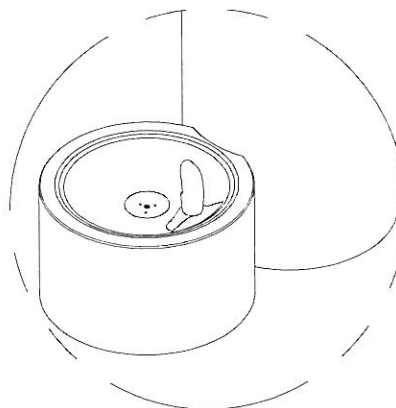
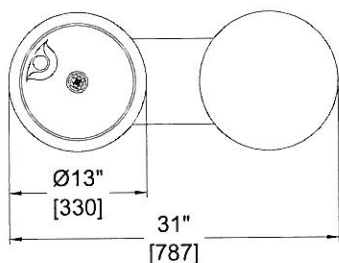

**OPTIONAL -PF  
PET FOUNTAIN  
DETAIL**

**GENERAL NOTES:**

1. ALL DIMENSIONS ARE IN INCHES [MM].
2. STOP VALVE NOT PROVIDED.

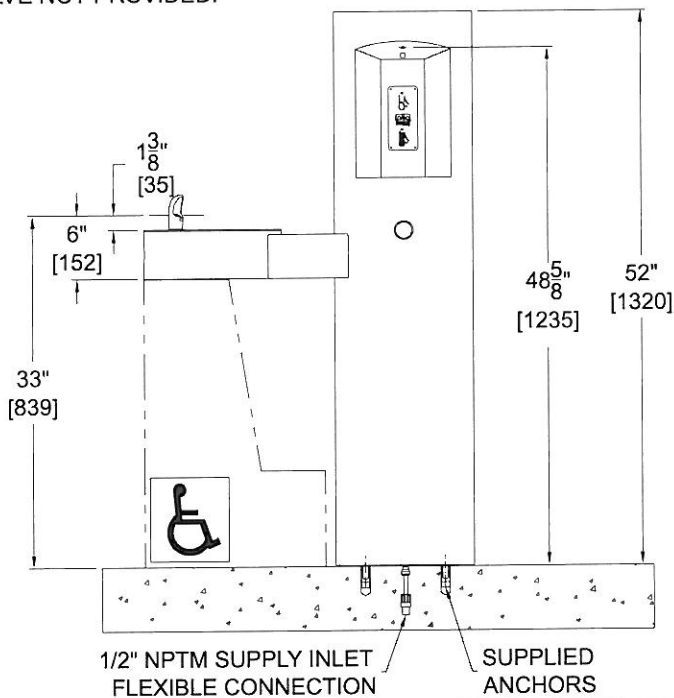

**ONE YEAR LIMITED WARRANTY** - Parts are warranted for one (1) year from date of shipment.

<b>SELECTION SUMMARY &amp; APPROVAL FOR MANUFACTURING</b>	Model Number & Options _____	Quantity _____	<p>All dimensions are nominal and subject to change without notice. Murdock assumes no responsibility for use of void or suspended data. © Copyright Murdock Mfg., Morris Group International Please visit <a href="http://www.murdockmfg.com">www.murdockmfg.com</a> for most current specifications.</p>
	Company _____		
	Contact _____	Title _____	
	Signature (Approval for Manufacturing) _____	Date _____	

**MURDOCK MFG.** • 15125 Proctor Avenue • City of Industry, CA 91746 USA  
 Phone 800-453-7465 or 626-333-2543 • Fax 626-855-4860 • [www.murdockmfg.com](http://www.murdockmfg.com)

Member of MORRIS GROUP