

**OFFICIAL  
CONTRACT DOCUMENTS  
AND  
SPECIFICATIONS**

**FOR**

**Expansion Area 3 Pump Station  
(Contract No. 1) and Force Main  
(Contract No. 2) Improvements**

**Wastewater System Improvements  
Division of Water Quality  
Lexington Fayette Urban County Government**

**Remedial Measures Plan ID No. CR 2 and 3**

**LFUCG Bid No. 106 - 2017**

**Date: November 2017**

**PREPARED BY:**

**HDR Engineering, Inc.**

**Volume 1**



## TABLE OF CONTENTS

<u>Division</u>	<u>Section</u>	<u>Title</u>	<u>Pages</u>
0		<b><u>PROCUREMENT AND CONTRACTING REQUIREMENTS</u></b>	
	00100	Advertisement for Bids	1-4
	00300	Information Available to Bidders	1-12
	00320	Geotechnical Data	1-61
	00410A	EA3 Pump Station (Contract No. 1) Bid Form	1-31
	00410B	EA3 Force Main (Contract No. 2) Bid Form	1-30
	00510A	EA3 Pump Station (Contract No. 1) Notice of Award	1-1
	00510B	EA3 Force Main (Contract No. 2) Notice of Award	1-1
	00520A	EA3 Pump Station (Contract No. 1) Agreement	1-4
	00520B	EA3 Force Main (Contract No. 2) Agreement	1-4
	00550A	EA3 Pump Station (Contract No. 1) Notice to Proceed	1-1
	00550B	EA3 Force Main (Contract No. 2) Notice to Proceed	1-1
	00600	Bonds and Certificates	1-19
	00700	General Conditions	1-69
	00800	Supplementary Conditions	1-15
	00810	Supplementary General Conditions	1-54
	00815	Guidance for the Implementation American Iron and Steel Provisions	1-21
	00820	Wage Determination Schedule	1-7
	00890	Permits	1-28
	00910	Addenda	1-1
1		<b><u>GENERAL REQUIREMENTS</u></b>	
	01010	Summary of Work	1-7
	01025	Measurement and Payment	1-5
	01040	Coordination	1-1
	01200	Project Meetings	1-1
	01210	Allowances	1-3
	01300	Submittals	1-5
	01320	Progress Schedules	1-2
	01400	Quality Control	1-2
	01510	Temporary Utilities	1-3
	01515	Field Offices	1-2
	01520	Maintenance of Utilities	1-2
	01530	Protection of Existing Utilities	1-2

01550	Site Access and Storage	1-2
01560	Temporary Environmental Controls	1-4
01580	Project Identification Signs	1-3
01631	Products and Substitutions	1-4
01731	Cutting and Patching	1-2
01740	Cleaning	1-2
01770	Project Closeout	1-3
01780	Operations and Maintenance Manuals	1-5
01782	Warranties and Bonds	1-2
01785	Project Record Documents	1-2

**2**

**SITE CONSTRUCTION**

02223	Embankments	1-4
02225	Excavating, Backfilling, and Compacting For Sewers	1-3
02240	Dewatering	1-1
02260	Excavation Support and Protection	1-3
02371	SWPPP	1-12
02372	Erosion and Sediment Control	1-58
02374	ESC Permitting, Inspection, and Permitting Procedures	1-6
02400	Boring and Jacking	1-4
02505	Water Piping	1-5
02515	Valves	1-2
02517	Hydrants	1-2
02531	Sewage Force Mains	1-13
02532	Sewage Collection Lines	1-12
02608	Manholes	1-7
02700	Asphaltic Concrete Paving	1-2
02775	Sidewalks	1-2

**3**

**CONCRETE**

03100	Concrete Formwork	1-6
03200	Reinforcing Steel	1-5
03250	Concrete Accessories	1-9
03290	Joints in Concrete	1-3
03300	Cast-In-Place Concrete	1-21
03350	Concrete Finishes	1-5
03370	Concrete Curing	1-4
03400	Precast Concrete	1-4
03600	Grout	1-4

4		<b><u>MASONRY</u></b>	
	04200	Unit Masonry	1-11
5		<b><u>METALS</u></b>	
	05010	Metal Materials	1-4
	05120	Structural Steel	1-4
	05511	Aluminum Ladders	1-3
	05520	Handrails and Railings	1-6
	05530	Grating and Floor Hatches	1-3
6		<b><u>WOOD &amp; PLASTIC</u></b>	
	06100	Rough Carpentry	1-4
	06176	Metal-Plate-Connected Wood Trusses	1-4
	06600	Fiberglass Reinforced Plastic Products and Fabrications	1-9
7		<b><u>THERMAL &amp; MOISTURE PROTECTION</u></b>	
	07175	Water Repellents	1-2
	07200	Insulation	1-3
	07415	Standing Seam Metal Roofing	1-4
	07600	Flashing and Sheet Metal	1-2
	07700	Roof Specialties and Accessories	1-2
	07900	Joint Sealers	1-5
8		<b><u>WINDOWS &amp; DOORS</u></b>	
	08330	Overhead Coiling Doors	1-3
	08342	Fiberglass Doors and Door Frames	1-6
	08710	Finish Hardware	1-4
9		<b><u>FINISHES</u></b>	
	09250	Gypsum Board (AD #6)	1-5
	09961	High Performance Paints and Coatings-Wastewater	1-12
	09660	Vinyl Composition Tile Flooring and Resilient Base (AD #6)	1-4
10		<b><u>SPECIALTIES</u></b>	
	10210	Metal Wall Louvers	1-3
	10441	Fire Extinguishers	1-2
	10800	Toilet and Bath Accessories	1-4

**11****EQUIPMENT**

11133	Submersible Sump Pumps	1-4
11285	Slide Gates	1-3
11290	Interior Process Piping	1-7
11295	Interior Process Valves	1-3
11310	Solids Handling Submersible Sewage Pumps	1-13
11420	Mechanical Screens and Screenings Compactors	1-21
11421	Mechanical Screens and Screenings Compactors Duperon (AD #4)	1-19

**Division 12 – Not Used****13****SPECIAL CONSTRUCTION**

13209	Chemical Feed System	1-10
13252	Activated Carbon Adsorber Odor Control System	1-20

**Division 14 – Not Used****15****MECHANICAL**

15010	General Mechanical Provisions	1-19
15015	Sleeves and Penetrations	1-2
15022	Lubrication and Packing	1-1
15060	Pipe and Pipe Fittings – General	1-10
15080	Piping Specialties	1-3
15090	Hangers, Supports, and Anchors	1-6
15095	Expansion Compensation and Vibration Elimination	1-4
15100	Valves	1-5
15180	Thermal Insulation	1-9
15410	Plumbing Piping	1-3
15430	Plumbing Specialties	1-6
15440	Plumbing Fixtures	1-3
15450	Plumbing Equipment	1-4
15535	Refrigeration Piping and Specialties	1-4
15620	Direct Heaters	1-3
15782	Unitary Air Conditioners and Heat Pumps	1-7

15810	Ductwork	1-4
15815	Ductwork Accessories	1-3
15830	Air Outlets and Inlets	1-3
15882	Fans	1-4
15892	Fiberglass Reinforced Plastic Duct (AD #6)	1-9
15910	HVAC Controls and Instrumentation	1-4
15961	Testing, Adjusting and Balancing - Air Systems	1-6

**16**

**ELECTRICAL**

16050	Basic Electrical Materials and Methods	1-15
16060	Secondary Grounding	1-2
16070	Supporting Devices	1-1
16075	Electrical Identification	1-1
16120	Conductors and Cables	1-6
16130	Raceways	1-7
16131	Boxes	1-3
16140	Wiring Devices	1-2
16150	Wire Connections and Connecting Devices	1-3
16170	Safety Switches	1-2
16220	Motors	1-5
16225	Electric Valve and Gate Actuators	1-3
16280	Surge Protection Devices	1-6
16440	Motor Control	1-5
16441	Switchboards	1-2
16442	Panelboards	1-3
16446	Variable Frequency Drives	1-7
16460	Small Power and Miscellaneous Transformers	1-2
16495	Switchboard Matting	1-1
16496	Automatic Transfer Switch	1-8
16500	Lighting	1-3
16620	Packaged Engine Generator Systems	1-11
16670	Lightning Protection Systems (Air Terminals)	1-2
16710	Communication Systems	1-2
16900	Controls	1-2

**17**

**INSTRUMENTATION**

17311	PLC Hardware and Software	1-16
17312	Radio Telemetry Equipment	1-4

17410	Basic Measurement and Control Instrumentation Materials and Methods	1-7
17420	Instruments	1-9
17430	Boxes, Panels and Control Centers	1-4
17480	Instrument Lists and Reports	1-4
17490	Measurement and Control Commissioning	1-4
17491	Permanent Flow Monitoring Equipment	1-5

### **APPENDICES**

A	LFUCG Standard Drawings 2008	
B	LFUCG Sanitary Sewer & Pumping Station Standard Drawings 2009	
C	RMP Standard Details	



## SECTION 00100 - ADVERTISEMENT FOR BIDS

### 1.01 INVITATION

Sealed proposals for the following work will be received by the Lexington-Fayette Urban County Government (LFUCG) **until 2:00, local time, September 7, 2017** for furnishing all labor and/or materials and performing all work as set forth in the Contract Documents prepared by and for Lexington-Fayette Urban County Government, Division of Water Quality (OWNER). Immediately following the scheduled closing time for reception of Bids, all proposals which have been submitted in accordance with the above will be publicly opened and read aloud.

### 1.02 DESCRIPTION OF WORK

The project includes providing all construction supervision, labor, materials, tools, test equipment necessary for the construction of the EA3 Pumping Station and Force Main. The project includes but is not limited to Contract No 1 a LFUCG Class A pumping station with mechanical screening, screenings compactor, four (4) submersible sewage pumps, two (2) sump pumps, building with screening room, dumpster room, odor control room, electrical room and emergency generator room. The Force Main project Contract No. 2 includes approximately 5,550 LF of 24" PVC force main. The project will be bid as two separate bids, EA3 Pump Station and the EA3 Force Main utilizing separate bid forms. Contractors may bid on one or both tasks.

### 1.03 OBTAINING PLANS, SPECIFICATIONS, AND BID DOCUMENTS

Plans, Specifications, and Contract Documents may be obtained from Lynn Imaging, 328 Old Vine Street, Lexington, KY 40507, (859) 255-1021 or ([www.lynnimaging.com](http://www.lynnimaging.com)) and click on plan room for a non-refundable price of reproduction for each full set of plans and documents. Contract Documents may be examined at the following places:

LFUCG  
Division of Central Purchasing  
200 East Main Street  
Third Floor, Room 338  
Lexington, KY 40507  
(859) 258-3320

McGraw-Hill Co./F.W. Dodge  
2321 Fortune Drive  
Suite 112-A  
Lexington, KY 40509

LFUCG  
Division of Water Quality  
125 Lisle Industrial Avenue  
Lexington, KY 40511  
(859) 425-2400

Builders Exchange  
1035 Strader Drive  
Suite 100  
Lexington, KY 40505  
(859) 288-0011

### 1.04 METHOD OF RECEIVING BIDS

Bids will be received from Prime contracting firms on a line item unit price basis. Bids shall be submitted in the manner and subject to the conditions as set forth and described in the Information Available to Bidders and Bid Form. Sealed Bids shall be clearly marked on the outside of the envelope as follows: Company Name and Address, Bid Invitation Number, and the Project Name. Bids are to remain sealed until official Bid closure time.

## 1.05 METHOD OF AWARD

Determination of the successful Bid will be based on the lowest responsive and responsible Bidder whose qualifications indicate the award will be in the best interest of the OWNER and whose Bid/proposal complies with all the prescribed requirements. No Notice of Award will be given until the OWNER has concluded such investigation as deemed necessary to establish the responsibility, qualifications and financial ability of Bidders to do the work in accordance with the Contract Documents to the satisfaction of the OWNER within the time prescribed. The OWNER reserves the right to reject the Bid of any Bidder who does not pass such investigation to the OWNER's satisfaction. In analyzing Bids, the OWNER may take into consideration alternate and unit prices, if requested by the Bid forms.

## 1.06 BID WITHDRAWAL

No Bidder may withdraw his Bid for a period of ninety (90) calendar days after the closing date for receipt of Bids. Errors and omissions will not be cause for withdrawal of Bid without forfeit of Bid Bond. Bids may be withdrawn in person prior to the closing date of receipt of Bids.

## 1.07 BID SECURITY

All Bids shall be accompanied by a Bid Bond of not less than five percent (5%) of the amount of the Bid executed by a Surety Company authorized to do business in the Commonwealth of Kentucky and countersigned by a licensed Kentucky Resident Agent, representing the Surety Company. Certified Check or Bid Bond shall be payable to Lexington-Fayette Urban County Government.

## 1.08 SUBMISSION OF BIDS

~~Contractors shall submit their Bids to the Lexington-Fayette Urban County Government, Division of Purchasing, Third Floor, 200 East Main Street, Lexington, Kentucky 40507. Bids shall be submitted in a sealed envelope not later than 2:00 p.m. (local time) July 27, 2017. Sealed proposals shall be marked clearly on the outside of the container "**Sealed Proposal for: Expansion Area 3 Pump Station (Contract No. 1) and Force Main (Contract No. 2) Improvements** to be opened at 2:00 p.m. Local Time, September 7, 2017. Bids received after the scheduled closing time for receipt of Bids will not be considered and will be returned unopened.~~ Contractors shall submit their Bids to the Lexington-Fayette Urban County Government, Division of Purchasing, Third Floor, 200 East Main Street, Lexington, Kentucky 40507. Bids shall be submitted in a sealed envelope not later than 2:00 p.m. (local time) September 24-26 (AD #5), 2017. "**Sealed proposals shall be marked clearly on the outside of the container "**Sealed Proposal for: Expansion Area 3 Pump Station (Contract No. 1) and Force Main (Contract No. 2) Improvements** to be opened at 2:00 p.m. Local Time, September 21, 2017. Bids received after the scheduled closing time for receipt of Bids will not be considered and will be returned unopened.**" (AD #1)

## 1.09 RIGHT TO REJECT

The Lexington-Fayette Urban County Government reserves the right to reject any and all Bids and to waive all informalities and/or technicalities where the best interest of the Lexington-Fayette Urban County Government may be served.

## 1.10 NOTICE CONCERNING MWDBE GOAL

Notice of requirement for Affirmative Action to ensure Equal Employment Opportunities and Disadvantaged Business Enterprises (DBE), Minority-Owned Business Enterprises (MBE), Veteran-Owned Small Businesses (VOSB) and Woman-Owned Business Enterprises (WBE) Contract participation.

LFUCG has set a goal that not less than ten percent (10%) of the total value of this Contract be subcontracted to MWDBEs. The Lexington Fayette Urban County Government also has set a goal that not less than three percent (3%) of the total value of this Contract be subcontracted to Veteran-owned Small Businesses. The goal for the utilization of MWDBEs as well as Veteran subcontractors is a recommended goal. Contractor(s) who fail to meet such goal will be expected to provide written explanations to the Director of the Division of Purchasing of efforts they have made to accomplish the recommended goal, and the extent to which they are successful in accomplishing the recommended goal will be a consideration in the procurement process. Depending on the funding source, other MWDBE goals may apply. For assistance in locating MWDBE Subcontractors contact:

Sherita Miller, Division of Central Purchasing  
LFUCG  
200 East Main Street, 3rd Floor, Room 338  
Lexington, Kentucky 40507  
[smiller@lexingtonky.gov](mailto:smiller@lexingtonky.gov)

## 1.11 PRE-BID MEETING

~~A non-mandatory pre-Bid meeting will be held at 9:00 a.m. local time, August 17, 2017 at 125 Lisle Industrial Avenue, Suite 18, Lexington, KY 40511. "A Mandatory pre-Bid meeting will be held at 9:00 a.m. local time, August 24, 2017 at 125 Lisle Industrial Avenue, Tate Bldg. 1<sup>st</sup> Floor, Suite 18, Lexington, KY 40511." (AD #1)~~

## 1.12 STATE REVOLVING LOAN REQUIREMENTS

This project may be partially or entirely funded by the Kentucky Infrastructure Revolving Loan Fund.

Bidders must comply with Title VI of the Civil Rights Act of 1964, the Anti-Kickback Act, and the Contract Work Hours Standard Act.

Bidders must comply with the President's Executive Order No.11246 as amended, which prohibits discrimination in employment regarding race, creed, color, sex or national origin.

Successful Bidder shall comply with 41 CFR 60-4, in regard to affirmative action, to insure equal opportunity to females and minorities and will apply the time tables and goal set forth in 40 CFR 60-4.

The procurement and performance of this contract are subject to the requirements of the Davis-Bacon Act.

Successful Bidder shall make positive efforts to use small, minority, women owned and disadvantaged businesses.

Attention of bidders is particularly called to the conditions of employment to be observed and minimum wage rates to be paid under the contract, Section 3, Segregated Facility, Section 109

and E.O. 11246 and Title VI. Minority bidders are encouraged to bid.

**Successful Bidder is required to employ the six "Good Faith Efforts" as listed in EPA's Disadvantaged Business Enterprise Program when soliciting subcontractors and suppliers. Documentation of these efforts will be a required submittal prior to Contract Award. See Supplemental General Conditions for Clean Water State Revolving Fund (Section 00810, page 30) included in the Contract Documents.**

The contract award will be made in writing to the lowest responsive and responsible bidder whose qualifications indicate the award will be in the best interest of the OWNER and whose bid/proposal complies with all the prescribed requirements. No Notice of Award will be given until the OWNER has concluded such investigation as deemed necessary to establish the responsibility, qualifications and financial ability of Bidders to do the work in accordance with the Contract Documents to the satisfaction of the OWNER within the time prescribed. The OWNER reserves the right to reject the Bid of any Bidder who does not pass such investigation to the OWNER's satisfaction. In analyzing Bids, the OWNER may take into consideration alternate and unit prices, if requested by the Bid forms.

### **1.13 CONSENT DECREE REQUIREMENTS**

The work to be provided through this Bid will assist the Lexington-Fayette Urban County Government (the "Owner") in successfully implementing the Agreement (Contract) and complying with any requirements which are related to the CONSENT DECREE entered in a case styled *United States & Commonwealth of Kentucky v. Lexington-Fayette Urban County Government*, United States District Court for the Eastern District of Kentucky, Civil Action No. 5:06-cv-386-KSF (the "CONSENT DECREE"). The services provided through this Bid are hereinafter referred to as the Agreement (Contract). The primary goal of the Agreement (Contract) is to provide the owner with the technical support and/or construction services necessary to successfully meet the obligations and deadlines of the CONSENT DECREE.

The Bidder shall familiarize itself with and shall at all times comply with the CONSENT DECREE, and all federal, state and local laws, ordinances, and regulations that in any manner affect the Agreement (Contract). Time is of the essence in the performance of Agreement (Contract). Bidder is aware that the Owner is subject to penalties for non-compliance with the CONSENT DECREE deadlines.

If delays result solely by reason of acts of the Bidder, the Bidder shall be held liable for any financial penalties incurred by the Owner as a result of the delay, including but not limited to those assessed pursuant to the CONSENT DECREE. In the event the parties cannot mutually agree upon the cause(s) associated with the delays in completing project deliverables, the Bidder must immediately notify the Owner in the event of such delay, and provide the Owner a written action plan within five (5) business days on how it will attempt to resolve the delay.

In the event that Bidder's delay or other nonperformance of its obligations hereunder results in the imposition of penalties against the Owner pursuant to the CONSENT DECREE, or the Owner otherwise suffers damage as a result of such delay or nonperformance, Bidder shall be solely liable to Owner for any and all such damages, including any costs and attorney's fees.

An electronic version of the CONSENT DECREE is available on the LFUCG web page for review or to print a copy at no charge.

END OF SECTION

## **SECTION 00300 – INFORMATION AVAILABLE TO BIDDERS**

### **1.01 RECEIPT AND OPENING OF BIDS**

The Lexington-Fayette Urban County Government (herein called the Owner) invites Bids from firms on the project described in the Advertisement for Bids. The Owner will receive Bids at the Division of Purchasing, at the time and in the manner set forth in the Advertisement for Bids, and the Bids will then be publicly opened and read aloud. The Owner may consider informal any Bid not prepared and submitted in accordance with the provisions hereof and may waive any informalities or reject any and all Bids. Any Bid may be withdrawn prior to the scheduled time for the opening of Bids or authorized postponement thereof. Any Bid received after the time and date specified shall not be considered. No Bidder may withdraw a Bid within ninety (90) days after the actual time and date of the Bid opening, but Owner may, in its sole discretion, release any Bid and return the Bid Security prior to that date.

The Lexington-Fayette Urban County Government assumes no responsibility for Bids that are not addressed and delivered as indicated above. Bids that are not delivered to the Division of Central Purchasing by the stated time and date will be rejected.

### **1.02 PREPARATION OF BID**

Each Bid must be submitted on the prescribed Bid Form. All blank spaces for the Bid prices must be filled in, either in ink or typewritten, for both unit prices and extensions. Totals for each Bid item must be added to show the total amount of the Bid. Each Bid must be submitted in a sealed envelope bearing on the outside the name of the Bidder, the Bidder's address, the name of the project, the invitation number and time and date for which the Bid is submitted. Bids must be addressed to the Director of Purchasing, Lexington-Fayette Urban County Government, Third Floor, 200 East Main Street, Lexington, Kentucky 40507. If forwarded by mail, the sealed envelope containing the Bid must be enclosed in another envelope addressed as specified above.

### **1.03 SUBCONTRACTS**

The Bidder is specifically advised that any person, firm, or other party to whom it is proposed to award a subcontract under this Contract must be acceptable to the Owner. All proposed subcontractors must be identified on Bid Form. Prior to the award of Contract, the Owner or the Owner's representative will advise the Contractor of the acceptance and approval thereof or of any action necessary to be taken. Should any Subcontractor be rejected by the Owner, the Contractor shall present a new name and/or firm to the Owner at no change in the Contract Price.

### **1.04 QUALIFICATIONS OF BIDDER**

The Owner may make such investigations as the Owner deems necessary to determine the ability of the Bidder to perform the Work, and the Bidder shall furnish to the Owner all such information and data for this purpose as the Owner may request. The Owner reserves the right to reject any Bid if the evidence submitted by, or investigation of, such Bidder fails to satisfy the Owner that such Bidder is properly qualified to carry out the obligations of the Agreement (Contract) and to complete the Work contemplated therein. Conditional Bids will not be accepted.

In evaluating Bids, Owner shall consider the qualifications of the Bidders, whether or not the Bids comply with the prescribed requirements, and alternatives and unit or lump sum prices, as requested. Owner may consider maintenance requirements, performance data, and disruption or damage to private property. The contract, if awarded, will be awarded to the lowest, qualified, responsible Bidder based upon Owner's evaluation which indicates that the award will be in the best interest of Owner and the general public.

In the event there is any question as to the Bidder's qualifications and ability to complete the work, a final determination will be made in accordance with a fair evaluation by the Lexington-Fayette Urban County Government of the above listed elements.

- A. If the Owner requires filling out a detailed financial statement, the Bidder may provide its current certified financial statement(s) for the required time interval.
- B. Corporate firms are required to be registered and in good standing with the requirements and provisions of the Office of the Secretary of State, Commonwealth of Kentucky.
- C. Good standing with Public Works Act - any Contractor and/or subcontractors in violation of any wage or work act provisions (KRS 337.510 to KRS 337.550) are prohibited by Statutory Act (KRS 337.990) from bidding on or working on any and all public works contracts, either in their name or in the name of any other company, firm or other entity in which he might be interested. No Bid from a prime contractor in violation of the Act can be considered, nor will any subcontractor in violation of the Act be approved and/or accepted. The responsibility for the qualifications of the subcontractor is solely that of the prime contractor.
- D. Documents Required of Contractor - (1) A sworn statement signed by the President or owner of the Company regarding all current work in progress anywhere; (2) A document showing the percent of completion of each project and the total worth of each project; and (3) Documentation showing the percentage of the DBE employment levels on each project of the Bidder's current work force, and DBE participation levels for Subcontractors.
- E. Optional Owner Requirements - The Owner, at its discretion, may require the Bidder/Contractor to provide: (1) A current detailed financial statement for a period including up to 3 prior years. (2) Financial security or insurance in amounts and kinds acceptable to the Owner to meet the financial responsibility requirements for the Contractor to indemnify the Owner. (3) Additional information and/or DBE work force data, as well as DBE participation data.
- F. Each Bidder agrees to waive any claim it has or may have against the Owner, the Architect/Engineer, and their respective employees, arising out of or in connection with the administration, evaluation, or recommendation of any Bid.

#### **1.05 BID SECURITY**

- A. Each Bid must be accompanied by a Bid bond prepared on a Form of Bid Bond and attached thereto, duly executed by the Bidder as principal and having as surety thereon a surety company approved by the Owner, in the amount of 5% of the Bid. Such Bid bond will be returned to the unsuccessful Bidder(s) only upon written request to the Director of Central Purchasing within seven (7) days of opening of Bids. Bid bond shall be made payable to the Lexington-Fayette Urban County Government. Bid security is not required for projects under \$50,000.
- B. Bonds shall be placed with an agent licensed in Kentucky with surety authorized to do business within the state. When the premium is paid for such coverage, the full commission payable shall be paid to such local agent who shall not divide such commission with any person other than a duly licensed resident local agent.

#### **1.06 LIQUIDATED DAMAGES FOR FAILURE TO ENTER INTO CONTRACT**

The successful Bidder, upon his failure or refusal to execute and deliver the Contract and bonds required within ten (10) days after he has received notice of the acceptance of his Bid, shall forfeit to the Owner, as liquidated damages for such failure or refusal, the security deposited with his Bid.

#### **1.07 TIME OF COMPLETION AND LIQUIDATED DAMAGES**

Bidder must agree to commence work on or before a date to be specified in a written "Notice to Proceed" from the Owner and to fully complete the Project within the time as specified in the Contract Documents. Bidder must agree also to pay liquidated damages for each consecutive calendar day thereafter as specified in the Contract Documents.

#### **1.08 EXAMINATION OF CONTRACT DOCUMENTS AND SITE**

- A. It is the responsibility of each Bidder before submitting a Bid, to (a) examine the Contract Documents thoroughly, (b) visit the site(s) to become familiar with local conditions that may affect cost, progress, performance or furnishing of the work, (c) consider Federal, State and Local laws and regulations that may affect cost, progress, performance or furnishing of the work, (d) study and carefully correlate Bidder's observations with the Contract Documents, and (e) notify Engineer of all conflicts, errors or discrepancies in the Contract Documents.
- B. Bidders should examine the requirements of the General Conditions for information pertaining to subsurface conditions, underground structures, underground facilities, and availability of lands, easements, and rights-of-way. The completeness of data, presented in the Contract Documents, pertaining to subsurface conditions, underground structures, and underground facilities for the purposes of bidding or construction is not assured. The Bidder will, at Bidder's own expense, make or obtain any additional examinations, investigations, explorations, tests and studies and obtain any additional information and data which pertain to the physical conditions (surface and subsurface) which may affect cost, progress, performance or furnishing of the Work and which Bidder deems necessary to determine its Bid for performing and furnishing the Work in accordance with the time, price, and other terms and conditions of the Contract Documents. On request in advance, Owner will provide access to the site to conduct such explorations and tests as each Bidder deems necessary for submission of a Bid. Bidder shall fill all holes, clean up and restore the site to its former condition upon completion of such explorations.
- C. The submission of a Bid will constitute an incontrovertible representation by the Bidder that Bidder has complied with every requirement of this Article; that without exception the Bid is premised upon furnishing and performing the Work required by the Contract Documents and such means, methods, techniques, sequences or procedures of construction as may be indicated in or required by the Contract Documents; and that the Contract Documents are sufficient in scope and detail to indicate and convey understanding of all terms and conditions for performance and furnishing of the Work.

#### **1.09 ADDENDA AND INTERPRETATIONS**

~~No interpretation of the meaning of the Contract Documents will be made to any Bidder orally. Every request for such interpretation should be in writing addressed to the Director of Central Purchasing, who in turn will have an addendum issued for the Lexington-Fayette Urban County Government, and to be given consideration must be received prior to the date fixed for the opening of Bids. Any and all such interpretations and any supplemental instructions will be in the~~

~~form of written addenda to the specifications. Acknowledgement of the receipt of addenda must be included with all submitted Bids. Failure of any Bidder to receive any such addendum or interpretation shall not relieve such Bidder from any obligation under his Bid as submitted. All addenda so issued shall become part of the Contract Documents. "No interpretation of the meaning of the Contract Documents will be made to any Bidder orally. Every request for such interpretation should be in writing addressed to the Director of Central Purchasing, in care of Brian Marcum at [brianm@lexingtonky.gov](mailto:brianm@lexingtonky.gov) (859) 258-3320, who in turn will have an addendum issued for the Lexington-Fayette Urban Country Government, and to be given consideration must be received prior to close of business September 8<sup>th</sup> 12<sup>th</sup>, 2017 (AD #3). Any and all such interpretations and any supplemental instructions will be in the form of written addenda to the specifications. Acknowledgement of the receipt of addenda must be included with all submitted Bids. Failure of any Bidder to receive any such addendum or interpretation shall not relieve such Bidder from any obligation under his Bid as submitted. All addenda so issued shall become part of the Contract Documents." (AD #1)~~

#### **1.10 SECURITY FOR FAITHFUL PERFORMANCE**

- A. Simultaneously with the delivery of the executed Contracts, the Contractor shall furnish 100% Performance, 100% Payment, and Erosion and Sediment Control Bonds as security for the faithful performance of this Contract and for payment of all persons performing labor on the Project under this Contract and furnishing materials in connection with this Contract. The surety on such bond or bonds shall be a duly authorized surety company satisfactory to the Owner and authorized to do business in the Commonwealth of Kentucky.
- B. The Contractor shall furnish the Warranty Bond upon completion of the Work, prior to the Owner's release of the final payment.
- C. All bonds required by this Contract and laws of this State shall be placed with agents licensed in the State of Kentucky. When the premium is paid for such coverage's, the full commission shall be paid to such local agent who shall not divide such commission with any person other than a duly licensed resident local agent.
- D. Contractor shall use standard Performance, Payment, Warranty, and Erosion and Sediment Control Bond forms such as documents provided with the Contract Documents or AIA form A312 (latest edition), for the Performance and Payment Bonds only.

#### **1.11 POWER OF ATTORNEY**

Attorney-in-fact who signs Bid bonds or Contract bonds must file with each bond a certified and effectively dated copy of their Power of Attorney.

#### **1.12 TAXES AND WORKMEN'S COMPENSATION**

The Contractor and subcontractor will be required to accept liability for payment of all payroll taxes, sales and use tax, and all other taxes or deductions required by local, state or federal law, such as social security measured by wages. Each shall carry Workmen's Compensation Insurance to the full amounts as required by Statutes and shall include the cost of all foregoing items in the Bid. The Contractor will not otherwise be reimbursed or compensated for such tax payments. The Contractor is urged to ascertain at his own risk his actual tax liability in connection with the execution or performance of this Contract.



### **1.13 LAWS AND REGULATIONS**

The Bidder's attention is directed to the fact that all applicable state laws, municipal ordinances, and the rules and regulations of all authorities having jurisdiction over construction of the Project shall apply to the Contract throughout, and they will be deemed to be included in the Contract, the same as though herein written out in full.

### **1.14 EROSION AND SEDIMENT CONTROL AND PERMITS**

The Contractor and Subcontractors performing Work on projects on behalf of the Owner shall also comply with all applicable federal, state, and local environmental regulations and all requirements and conditions set forth in specifications herein.

### **1.15 PREVAILING WAGE LAW AND MINIMUM HOURLY RATES**

Federal wage rates and regulations, required for this Project, will be as described in the Section 00820 herein. The Project Bid Forms include a Deductive Alternate for bidding the project without applying Davis Bacon wage rates.

### **1.16 AFFIRMATIVE ACTION PLAN**

The successful Bidder must submit with their bid the following items to the Urban County Government (see section 00410 – Bid Form):

- A. Affirmative Action Plan of the firm
- B. Current Work Force Analysis Form
- C. Good Faith Effort Documentation to meet the MWDBE goals.
- D. List of Disadvantaged Business Enterprise Subcontractors and the Dollar Value of each Subcontract

A Work Force Analysis on the prescribed form shall be submitted for each Contract. Failure to submit these items as required herein may result in disqualification of the Bidder from award of the Contract.

All submissions should be directed to:

Director, Division of Central Purchasing  
Lexington-Fayette Urban County Government  
200 East Main Street, Third Floor  
Lexington, KY 40507

### **1.17 CONTRACT TIME**

The number of calendar days within which the Work is to be substantially completed and ready for final payment (the Contract Time) is set forth in the Bid Form and the Agreement (Contract).

### **1.18 SUBSTITUTE OR "OR-EQUAL" ITEMS**

The Contract, if awarded, will be on the basis of materials and equipment described in the Drawings or specified in the Specifications without consideration of possible substitute or "or-equal" items. Whenever it is indicated in the Drawings or specified in the Specifications that a substitute or "or-equal" item of material or equipment may be furnished or used by the Contractor if acceptable to the Engineer and Owner, application for such acceptance will not be considered

by the Engineer and Owner until after the effective date of the Agreement (Contract). The procedure for submission of any such application by the Contractor and consideration by the Engineer and Owner is set forth in the General Conditions.

#### **1.19 EQUIPMENT MANUFACTURERS LIST**

The Equipment Manufacturers identified in the Equipment Manufacturers List are the only equipment manufacturers/suppliers to be considered in the Bid. There are and will be no other equals considered during the bidding phase for these equipment items. The Contractor may select any of the listed manufacturers for each item and must circle the selected manufacturer for each item at the time of Bid submission.

The design was completed based upon the first listed manufacturer, The Contractor, at no cost to the Owner, will be responsible for any changes to the structures, piping, electrical, instrumentation, or other to accommodate any required changes should a vendor other than the first listed be selected in the bid. This will include payment to the Engineer of Record for any required redesign.

#### **1.20 ALTERNATE BIDS**

**Bidders shall submit alternate Bids/proposals only if and when such alternate Bids/proposals have been specifically requested in an Advertisement for Bids.** If alternate Bids/proposals are requested in an Advertisement for Bids, the form of submission of such alternate Bid and the conditions under which such alternate Bids will be considered for award of a contract will be established in the Advertisement.

Any Bidder who submits a Bid incorporating an alternate proposal when alternate Bids/proposals have not been requested in the Advertisement for Bids shall have his/her Bid rejected as non-responsive.

Any Bidder who submits a Bid incorporating two (2) or more prices for an item or groups of items (unless such method of pricing is requested in the Advertisement for Bids), or which imposes conditions for acceptance other than those established in the Advertisement for Bids, shall have their Bid rejected as non-responsive.

#### **1.21 SIGNING OF AGREEMENT (CONTRACT)**

When Owner gives a Notice of Award to the successful Bidder, it will be accompanied by the required number of unsigned counterparts of the Agreement (Contract) with all other written Contract Documents attached. Within ten days thereafter, Contractor shall sign and deliver the required number of counterparts of the Agreement (Contract) and attached documents to Owner with the required Bonds, Certificate of Insurance, and Power of Attorney. The Owner will deliver one fully signed counterpart to Contractor at such time as it has been signed by the Mayor.

#### **1.22 ASSISTANCE TO BE OFFERED TO DISADVANTAGED BUSINESS ENTERPRISE (MWDBE) CONTRACTORS**

##### **A. Outreach for MWDBE(s)**

The Lexington-Fayette Urban County Government (LFUCG) maintains a database of MWDBE contractors and organizations. When a LFUCG construction project is advertised for bidding, notices are sent to companies registered at <https://lexingtonky.ionwave.net>. The notices describe the project and indicate the deadline for submitting bids.

If you wish to be added to the LFUCG MWDBE contractor database, please contact:

Sherita Miller, Division of Central Purchasing  
Lexington-Fayette Urban County Government  
200 East Main Street, Room 338  
Lexington, Kentucky 40507  
[smiller@lexingtonky.gov](mailto:smiller@lexingtonky.gov)

B. Bid Bond Assistance for MWDBE(s)

For those MWDBE contractors who wish to bid on LFUCG project, bid bond assistance is available. This bid bond assistance is in the form of a "Letter of Certification" which is accepted by the LFUCG's Division of Purchasing, in lieu of a bid bond. The "Letter of Certification" must be included in the bid package when it is submitted to the Division of Purchasing. The "Letter of Certification" will reference the specific project for which the bid is being submitted, and the time and date on which the bid is due. Bid bond assistance must be requested from the Lexington-Fayette Urban County Government's Division of Central Purchasing.

C. Eligibility for Bid Bond Assistance for MWDBE(s)

In order to be eligible for any Bid bonding assistance, a MWDBE construction company must be owned or controlled at the level of 51% or more by a member or members of a minority group or females. Prior to receiving assistance, a statement providing evidence of ownership and control of the company by a member or members of a minority group or females must be signed by the Owner or corporate officer and by an attorney or accountant submitted to:

Sherita Miller, Division of Central Purchasing  
Lexington-Fayette Urban County Government  
200 East Main Street, Room 338  
Lexington, Kentucky 40507  
[smiller@lexingtonky.gov](mailto:smiller@lexingtonky.gov)

D. MWDBE and Veteran Subcontractors

The LFUCG will, upon request, assist prime contractors in the procurement of eligible DBE and veteran subcontractors in an effort to achieve 10% minimum MWDBE goal and to achieve 3% minimum veteran goal.

For a list of eligible subcontractors, please contact:

Sherita Miller, Division of Central Purchasing  
Lexington-Fayette Urban County Government  
200 East Main Street, Room 338  
Lexington, Kentucky 40507  
[smiller@lexingtonky.gov](mailto:smiller@lexingtonky.gov)

## 1.23 MWDBE PARTICIPATION GOALS

A. GENERAL

1. The LFUCG request all potential contractors to make a concerted effort to include Minority-Owned (MBE), Woman-Owned (WBE), Disadvantaged (DBE) Business Enterprises and Veteran-Owned Small Businesses (VOSB) as subcontractors or suppliers in their bids.
2. Toward that end, the LFUCG has established 10% of total procurement costs as a Goal for participation of Minority-Owned, Woman-Owned and Disadvantaged Businesses on this contract.
3. The LFUCG has also established a 3% of total procurement costs as a Goal for participation of Veteran-Owned Small Businesses.
4. **It is therefore a request of each Bidder to include in its bid, the same goal (10%) for MWDBE participation and other requirements as outlined in this section.**

## B. PROCEDURES

1. The successful bidder will be required to report to the LFUCG, the dollar amounts of all payments submitted to Minority-Owned, Woman-Owned or Veteran-Owned subcontractors and suppliers for work done or materials purchased for this contract. (See EPA forms in section 00410 – Bid Form).
2. Replacement of a Minority-Owned, Woman-Owned or Veteran-Owned subcontractor or supplier listed in the original submittal must be requested in writing and must be accompanied by documentation of Good Faith Efforts to replace the subcontractor / supplier with another MWDBE Firm; this is subject to approval by the LFUCG. (See EPA forms in section 00410 – Bid Form).
3. For assistance in identifying qualified, certified businesses to solicit for potential contracting opportunities, bidders may contact:
  - a. The Lexington-Fayette Urban County Government, Division of Central Purchasing (859-258-3320)
4. The LFUCG will make every effort to notify interested MWDBE subcontractors and suppliers of each Bid Package, including information on the scope of work, the pre-bid meeting time and location, the bid date, and all other pertinent information regarding the project.

## C. DEFINITIONS

1. A Minority-Owned Business Enterprise (MBE) is defined as a business which is certified as being at least 51% owned and operated by persons of African American, Hispanic, Asian, Pacific Islander, American Indian or Alaskan Native Heritage.
2. A Woman-Owned Business Enterprise (WBE) is defined as a business which is certified as being at least 51% owned and operated by one or more Non-Minority Females.
3. A Disadvantaged Business (DBE) is defined as a business which is certified as being at least 51% owned and operated by a person(s) that are economically and socially disadvantaged.
4. A Veteran-Owned Small Business (VOSB) is defined as a business which is certified as being at least 51% owned and operated by a veteran and/or a service disabled veteran.
5. Good Faith Efforts are efforts that, given all relevant circumstances, a bidder or proposer actively and aggressively seeking to meet the goals, can reasonably be expected to make. In evaluating good faith efforts made toward achieving the goals, whether the bidder or proposer has performed the efforts outlined in the Obligations of Bidder for Good Faith Efforts outlined in this document will be considered, along with any other relevant factors.

## D. OBLIGATION OF BIDDER FOR GOOD FAITH EFFORTS

1. Bidders are required to employ each of the 6 Good Faith Efforts outlined in the bid documents. **These efforts have to be done and documented whether the bidder reached the 10% goal or not.**

2. Award of Contract shall be conditioned upon satisfaction of the requirements set forth herein.
3. See section 00410 – Bid Form for the MWDBE Participation Policy and 6 Good Faith Efforts.
4. **Failure to submit this information as requested may be cause for rejection of bid.**

## 1.24 MINORITY BUSINESS ENTERPRISE PROGRAM



Sherita Miller, MPA  
Minority Business Enterprise Liaison  
Division of Central Purchasing  
Lexington-Fayette Urban County Government  
200 East Main Street  
Lexington, KY 40507  
[smiller@lexingtonky.gov](mailto:smiller@lexingtonky.gov)  
859-258-3323

**OUR MISSION:** The mission of the Minority Business Enterprise Program is to facilitate the full participation of minority and women owned businesses in the procurement process and to promote economic inclusion as a business imperative essential to the long term economic viability of Lexington-Fayette Urban County Government.

To that end the city council adopted and implemented resolution 167-91—Disadvantaged Business Enterprise (DBE) 10% Goal Plan in July of 1991. The resolution states in part (a full copy is available in Central Purchasing):

*"A Resolution supporting adoption of the administrative plan for a ten percent (10%) Minimum goal for disadvantaged business enterprise participation in Lexington-Fayette Urban County Government construction and professional services contracts; Providing that as part of their bids on LFUCG construction contracts, general Contractors shall make a good faith effort to award at least ten percent (10%) of All subcontracts to disadvantaged business enterprises; providing that divisions of LFUCG shall make a good faith effort to award at least ten percent of their Professional services and other contracts to disadvantaged business enterprises..."*

A Disadvantaged Business Enterprise is defined as a business that has been certified as being at least 51% owned, operated and managed by a U.S. Citizen of the following groups:

- African-American
- Hispanic-American
- Asian/Pacific Islander
- Native American/Native Alaskan
- Non-Minority Female
- Economically and Socially Disadvantaged

In addition, to that end the city council also adopted and implemented resolution 167-91—Veteran-owned Businesses, 3% Goal Plan in July of 2015. The resolution states in part (a full copy is available in Central Purchasing):

*"A resolution adopting a three percent (3%) minimum goal for certified veteran-owned small businesses and service disabled veteran-owned businesses for certain of those Lexington-Fayette Urban County contracts related to construction for professional services, and authorizing the Division of Purchasing to adopt and implement guidelines and/or policies consistent with the provisions and intent of this resolution by no later than July 1, 2015."*

We have compiled the list below to help you locate certified MBE, WBE and DBE certified businesses. Below is a listing of contacts for LFUCG Certified MWDBEs and Veteran-Owned Small Businesses in (<https://lexingtonky.ionwave.net>)

<b>Business</b>	<b>Contact</b>	<b>Email Address</b>	<b>Phone</b>
<b>LFUCG</b>	Sherita Miller	<a href="mailto:smiller@lexingtonky.gov">smiller@lexingtonky.gov</a>	859-258-3323
<b>Commerce Lexington – Minority Business Development</b>	Tyrone Tyra	<a href="mailto:ttyra@commercelexington.com">ttyra@commercelexington.com</a>	859-226-1625
<b>Tri-State Minority Supplier Diversity Council</b>	Susan Marston	<a href="mailto:smarston@tsmsdc.com">smarston@tsmsdc.com</a>	502-365-9762
<b>Small Business Development Council</b>	Shirie Hawkins, UK SBDC	<a href="mailto:smack@uky.edu">smack@uky.edu</a>	859-257-7666
<b>Community Ventures Corporation</b>	Phyllis Alcorn	<a href="mailto:palcorn@cvky.org">palcorn@cvky.org</a>	859-231-0054
<b>KY Transportation Cabinet (KYTC)</b>	Melvin Bynes	<a href="mailto:Melvin.bynes2@ky.gov">Melvin.bynes2@ky.gov</a>	502-564-3601
<b>KYTC Pre-Qualification</b>	Shella Eagle	<a href="mailto:Shella.Eagle@ky.gov">Shella.Eagle@ky.gov</a>	502-782-4815
<b>Ohio River Valley Women’s Business Council (WBENC)</b>	Sheila Mixon	<a href="mailto:smixon@orwbc.org">smixon@orwbc.org</a>	513-487-6537
<b>Kentucky MWBE Certification Program</b>	Yvette Smith, Kentucky Finance Cabinet	<a href="mailto:Yvette.Smith@ky.gov">Yvette.Smith@ky.gov</a>	502-564-8099
<b>National Women Business Owner’s Council (NWBOC)</b>	Janet Harris-Lange	<a href="mailto:janet@nwbo.org">janet@nwbo.org</a>	800-675-5066
<b>Small Business Administration</b>	Robert Coffey	<a href="mailto:robertcoffey@sba.gov">robertcoffey@sba.gov</a>	502-582-5971
<b>LaVoz de Kentucky</b>	Andres Cruz	<a href="mailto:lavozdeky@yahoo.com">lavozdeky@yahoo.com</a>	859-621-2106
<b>The Key News Journal</b>	Patrice Muhammad	<a href="mailto:paatricem@keynewsjournal.com">paatricem@keynewsjournal.com</a>	859-373-9428

**1.25 OWNER PERMITS**

Bidder shall refer to Section 00890 regarding permits that have been obtained by the Owner.

**1.26 GEOTECHNICAL DATA**

Bidder shall refer to Section 00320 regarding available geotechnical data for this Contract.



## 1.27 BUY AMERICAN PROVISIONS

This project is subject to Division G, Title IV of H.R. 3547 (Appropriations Act) passed by the United States Congress on January 17, 2014. This portion of the act requires that for the construction, alteration, maintenance, or repair of a public water system or treatment works, all of the iron and steel products used in the project be produced in the United States.

In this section, the term "iron and steel products" means the following products made primarily of iron or steel: lined or unlined pipes and fittings, manhole covers and other municipal castings, hydrants, tanks, flanges, pipe clamps and restraints, valves, structural steel, reinforced precast concrete, and construction materials.

This requirement shall not apply in any case or category of cases in which the Administrator of the Environmental Protection Agency finds that (1) applying the requirement would be inconsistent with the public interest; (2) iron and steel products are not produced in the United States in sufficient and reasonably available quantities and of a satisfactory quality; or (3) inclusion of iron and steel products produced in the United States will increase the cost of the overall project by more than 25 percent.

Bidder shall refer to Section 00815 for additional information.

END OF SECTION

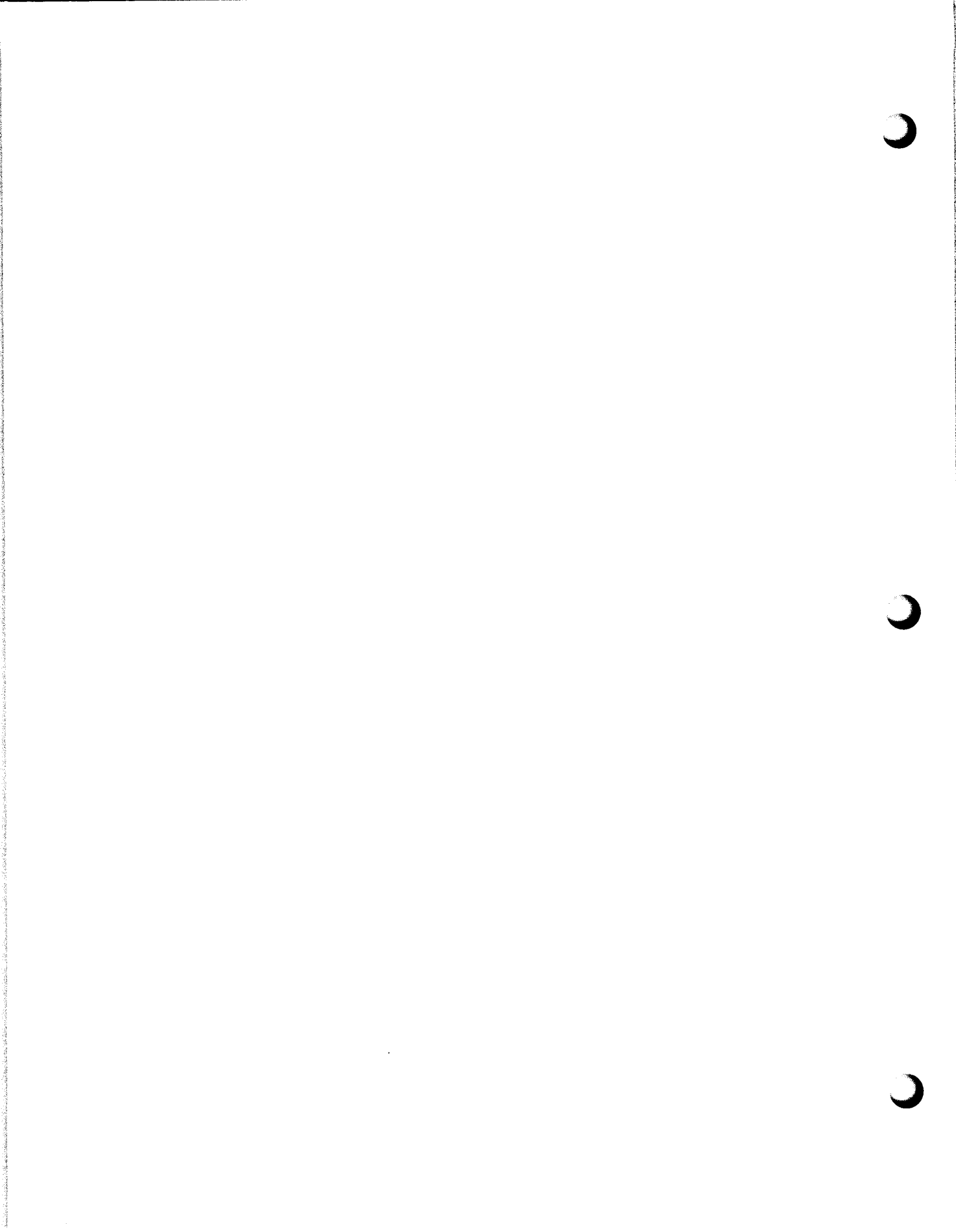

**SECTION 00320 – GEOTECHNICAL DATA**

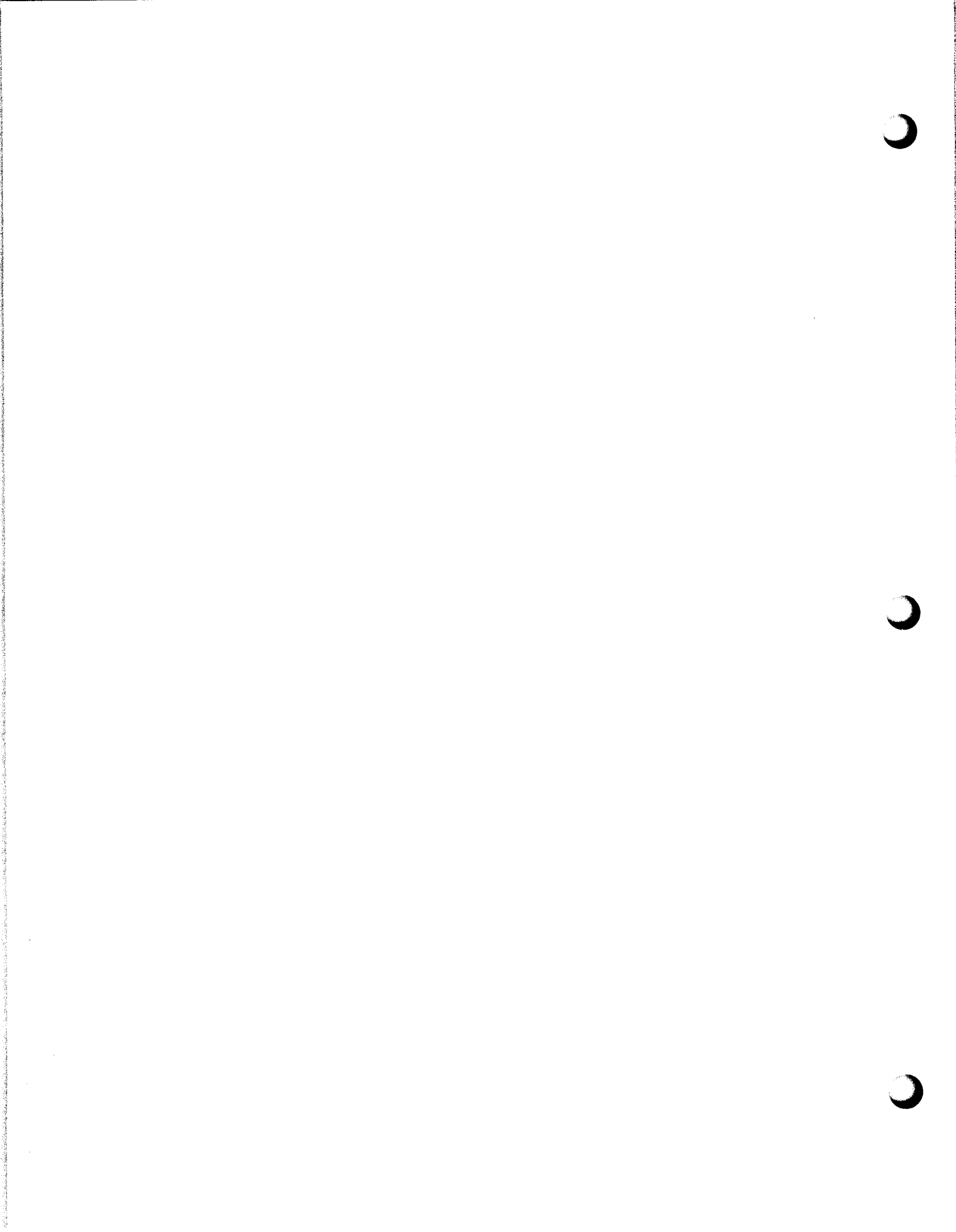

**LEXINGTON FAYETTE  
URBAN COUNTY  
GOVERNMENT (LFUCG) –  
Expansion Area 3 (EA3)  
Pump Station and Force  
Main Sewer**

**Report of Geotechnical  
Investigation**

**Expansion Area 3 (EA3) Pump  
Station and Force Main Sewer,  
Lexington, Kentucky**

**HDR Project No. 10041433  
Dept. 10079**

**February 2017**

*Prepared for:*  
**Lexington Fayette Urban County Government**

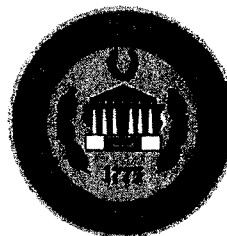

*Prepared by:*  
**HDR Engineering, Inc.**



**PAGE LEFT INTENTIONALLY BLANK**

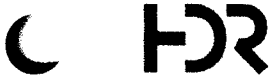

February 15, 2017

Mr. Benton Hanson, P.E.  
Project Manager  
HDR Engineering, Inc.  
2517 Sir Barton Way  
Lexington, Kentucky 40509

**RE: Report of Geotechnical Investigation  
Expansion Area 3 (EA3) Pump Station and Force Main Sewer in Lexington, Kentucky  
Lexington Fayette Urban County Government (LFUCG)**

Dear Mr. Hanson:

HDR, Inc. is pleased to provide the accompanying report, which presents the results of our geotechnical design of the proposed Expansion Area 3 (EA3) Pump Station and Force Main Sewer project for the Lexington Fayette Urban Government (LFUCG) in Lexington, Kentucky.

This report presents our findings, conclusions, and recommendations for the geotechnical aspects of the proposed construction. It has been our pleasure to serve you on this very important project. Please contact us if you have any questions or comments concerning this information.

Sincerely,

HDR ENGINEERING, Inc.

Bryan Robbins, EIT  
Geotechnical Engineer

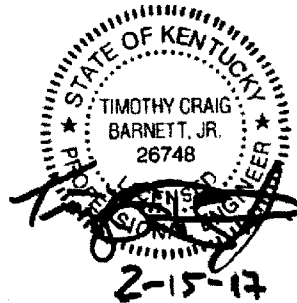

T. Craig Barnett, P.E.  
Geotechnical Engineer

Enclosure

hdrinc.com

2517 Sir Barton Way, Lexington, KY 40509-2275  
(859) 629-4800

**PAGE LEFT INTENTIONALLY BLANK**



---

**TABLE OF CONTENTS**

---

	<u>Page No.</u>
<b>1.0 INTRODUCTION.....</b>	<b>1</b>
<b>2.0 PROJECT DESCRIPTION .....</b>	<b>1</b>
<b>3.0 GEOLOGIC AND TOPOGRAPHIC SETTING .....</b>	<b>1</b>
<b>4.0 SUBSURFACE INVESTIGATION .....</b>	<b>2</b>
4.1 Initial Subsurface Investigation .....	2
4.2 Supplementary Subsurface Investigation .....	3
<b>5.0 SUBSURFACE CONDITIONS .....</b>	<b>4</b>
5.1 Force Main Rock Line Soundings.....	4
5.2 Pump Station Sample Borings.....	4
<b>6.0 LABORATORY TESTING AND RESULTS .....</b>	<b>4</b>
6.1 Classification Test Results for Cohesive Samples.....	5
6.2 Unconfined Compressive Strength Testing of Rock.....	5
<b>7.0 GEOLOGIC HAZARDS .....</b>	<b>5</b>
7.1 Faults .....	5
7.2 Karst Features.....	6
7.3 Corrosivity .....	6
<b>8.0 ENGINEERING ANALYSES .....</b>	<b>6</b>
8.1 Seismic Design Considerations .....	6
8.2 Shallow Foundations.....	7
8.2.1 Bearing Capacity of Spread Footings / Mat Foundation.....	7
8.2.2 Settlement of Possible Spread Footings.....	8
8.2.3 Construction Considerations.....	8
<b>9.0 RECOMMENDATIONS FOR CONSTRUCTION .....</b>	<b>8</b>
9.1 Below Grade Walls .....	8
9.2 Site Preparation and Excavations.....	9
9.3 Temporary Construction Excavations.....	9
9.4 Fill and Backfill Material .....	10
9.4.1 On-site Soils.....	10
9.4.2 Off-Site Materials .....	10
9.5 Fill Compaction and Placement Criteria .....	10
9.5.1 Percent Compaction and Moisture Control.....	10
9.5.2 Lift Thickness and Placement.....	11
9.6 Control of Surface Water and Runoff.....	11
9.7 Construction Monitoring Requirements .....	11
<b>10.0 LIMITATIONS .....</b>	<b>12</b>
<b>11.0 REFERENCES.....</b>	<b>12</b>

---

**LIST OF TABLES**

---

Table 1 – Summary of Initial SPT Sample Borings.....	2
Table 2 – Summary of Supplemental Rock Core Boring.....	3
Table 3 – Summary of Unconfined Compressive Strength Tests on Rock.....	5
Table 4 – Peak Ground Accelerations.....	7
Table 5 – Recommendations for Spread Footings/Mat Foundation Bearing on Bedrock.....	7

---

**LIST OF FIGURES (Following Text)**

---

1	Project Location Map
2	Bedrock Geology Map
3	Boring Location Map
4	Sounding Location Map
5	Karst Potential Map

---

**LIST OF ATTACHMENTS (Following Figures)**

---

A	Preliminary Project Plans
B	Rock Line Sounding Summary
C	Boring Logs and Laboratory Testing
D	Generalized Soil Profile
E	USGS Seismic Hazard Deaggregation Plots

**REPORT OF GEOTECHNICAL INVESTIGATION  
LEXINGTON FAYETTE URBAN COUNTY GOVERNMENT (LFUCG)  
EA3 PUMP STATION AND FORCE MAIN SEWER  
LEXINGTON, KENTUCKY**

**1.0 INTRODUCTION**

This report presents the results of the geotechnical investigation performed at the site of the proposed Expansion Area 3 (EA3) Pump Station and Force Main Sewer for the Lexington Fayette Urban County Government (LFUCG). The project site is located near the Newtown Pike and Interstate 75 interchange in Lexington, Kentucky. This report was prepared by HDR Engineering, Inc. (HDR) for LFUCG. A project location map is included as Figure 1.

This report presents HDR's findings, conclusions and recommendations regarding:

- Geologic setting;
- Subsurface soil, rock and groundwater conditions;
- Geologic Hazards;
- Evaluation of the engineering characteristics of the foundation soils and rock; and
- Recommendations for foundation design.

This report was prepared by a civil engineer specializing in geotechnical engineering and reviewed by a registered professional engineer in the State of Kentucky. The recommendations presented herein are based on the applicable standards of the profession at the time of this report within this geographic area. This report has been prepared for the exclusive use of the Lexington Fayette Urban County Government (LFUCG) for specific application to the proposed project, in accordance with generally accepted foundation engineering practices.

**2.0 PROJECT DESCRIPTION**

The site of the proposed LFUCG EA3 Pump Station and Force Main Sewer is located near the Newtown Pike and Interstate 75 (I-75) interchange in Fayette County, Kentucky. The proposed 24-inch Force Main Sewer will extend approximately 5,300 feet and discharge into a proposed Lower Griffin Gate Trunk Sewer. The proposed Force Main Sewer extends west from the proposed Pump Station, crosses beneath Newtown Pike and runs south adjacent to Newtown Pike before crossing beneath I-75. The proposed Class A Pump Station will have a firm capacity of 10 million gallons per day (MGD). The Pump Station will be equipped with a mechanical and manual screening room, an odor control room, a chemical feed system, an electrical room and a generator room. An open top dumpster will receive material from the screening compactor in a loadout area. The Pump Station building will consist of architecture that matches the adjoining Eaton Farm barns and buildings. Preliminary Project Plans are included as Attachment A.

**3.0 GEOLOGIC AND TOPOGRAPHIC SETTING**

Published geologic mapping, (Geologic Map of The Lexington East Quadrangle, Fayette and Bourbon Counties, Kentucky, GQ-683, W.C. MacQuown, Jr. and E. Dobrovlny, 1968), indicates the proposed site is underlain by shale and limestone belonging to the Tanglewood Limestone Member. The limestone is described as light-gray, medium- to coarse-grained and thin- to thick-bedded in primarily tabular beds. The limestone is also described as phosphatic, bioclastic, and sparingly to very fossiliferous with some irregular bedding and crossbedding. Limestone comprises approximately 80 percent of the member. The shale is described as limy, medium-gray and mostly interlaminated with fine-grained shaly limestone. In addition, the shale is described as weathering to reddish-brown soil. The published mapping suggests the member thickness ranges from 20 feet to 55 feet. A bedrock geology map of the project site is included as Figure 2.

Fayette County is located in central Kentucky in the Inner Blue Grass physiographic region of the state. The majority of the county can be described as a gently rolling limestone upland. Local relief for Fayette

County is typically less than 100 feet. The lowest elevation in the county is 549 feet and occurs at Valley View Ferry at the Kentucky River. Elevations of 950 feet and greater are common in the county, with the highest elevation recorded at 1070 feet. The elevation of downtown Lexington is 959 feet.

#### 4.0 SUBSURFACE INVESTIGATION

An initial subsurface investigation was performed by HDR beginning on September 20, 2016 that included rock line soundings and geotechnical sample borings for the proposed Force Main Sewer and Pump Station. However, a revised preliminary plan set indicates the proposed Pump Station has been relocated from the location utilized as the basis for the initial subsurface investigation. As a result, a supplementary subsurface investigation was performed by Horn and Associates, Inc. (Horn) based on the revised location of the Pump Station. The supplementary subsurface investigation was performed on January 30, 2017 and included both rock line soundings and a rock core boring. The revised Pump Station layout plan is included in Attachment A. The following sections summarize the initial and supplemental subsurface investigation performed at the project site.

#### 4.1 Initial Subsurface Investigation

The initial subsurface exploration consisted of completing 107 geotechnical borings, including 103 rock line soundings, three Standard Penetration Test (SPT) sample borings, and one SPT sample and rock core boring. The initial rock line soundings are designated herein as Soundings FM-1 through FM-103, and the initial SPT borings are designated as Borings PS-1 through PS-4. Rock line soundings FM-1 through FM-103 were advanced along the alignment of the proposed Force Main Sewer. Borings PS-1 through PS-4 were advanced near and within the footprint of the proposed Pump Station at its original location. Boring locations are depicted in Figure 3 and sounding locations are shown on Figure 4.

Table 1 provides a summary of the northing, easting, elevations and depths of the SPT sample borings advanced in and near the footprint of the proposed Pump Station at its original location. The boring locations were staked in the field by a representative of HDR and surveyed to determine the exact location of each boring. All measurements are expressed in feet and elevations are referenced to the North American Vertical Datum of 1988 (NAVD 88).

**Table 1 – Summary of Initial SPT Sample Borings**

Boring No.	Northing <sup>(1)</sup>	Easting <sup>(1)</sup>	Surface Elev. (feet)	Top of Rock Elev. (feet)	Refusal / Begin Rock Core Elev. (feet)	Length of Rock Core (feet)	Boring Termination Depth (feet)	Bottom of Boring Elev. (feet)
PS-1	220462.026	1574794.883	923.78	N/A	917.68	N/A	6.1	917.68
PS-2	220379.001	1574804.512	923.19	918.19	918.19	42.5	47.5	875.69
PS-3	220344.078	1574854.198	921.76	N/A	916.96	N/A	4.8	916.96
PS-4	220174.500	1574742.000	926.21	N/A	918.61	N/A	7.6	918.61

Note:

- (1) Northing and Easting coordinates referenced to the North American Datum of 1983 and the Kentucky North state plane coordinate zone.
- (2) Borings PS-1, PS-3 and PS-4 drilled to auger refusal. Auger refusal refers to using a carbide tipped tooth auger bit and may indicate the presence of weathered bedrock, boulders, rock remnants or competent bedrock. An exact determination cannot be made without rock coring.

A summary of the northing, easting, elevations and depths of the initial rock line soundings advanced along the Force Main Sewer alignment is included in Attachment B. The sounding locations were staked and surveyed in the field by a representative of HDR.

HDR performed the initial drilling and sampling operations beginning on September 20, 2016. The drill crew operated a track-mounted drill rig equipped with an automatic hammer and 3.25-inch hollow-stem augers. The drill crew generally performed soil sampling within Borings PS-1 to PS-4 beginning at a depth of 2.5 feet, and continued to collect soil samples at depths of 4.9 feet and 7.5 feet as subsurface soil and rock conditions permitted. Standard Penetration Testing (SPT) was performed at all four sample borings. Rock coring was performed upon auger refusal within Boring PS-2. The borings were checked for the presence of groundwater during and immediately after drilling. Rock line soundings FM-1 to FM-103 were advanced to auger refusal or to a depth of 8 feet, depending on which occurred first. The initial rock line soundings were performed every 50 feet along the Force Main Sewer alignment.

#### 4.2 Supplementary Subsurface Investigation

The supplementary subsurface exploration consisted of completing three geotechnical borings, including two rock line soundings and one rock core boring. The supplementary rock line soundings are designated herein as Soundings PS-6 and PS-7, and the supplementary rock core boring is designated as Boring PS-5. Rock line soundings PS-6 and PS-7 were advanced at proposed manholes MH-01B and MH-01, respectively. Boring PS-5 was advanced within the footprint of the proposed Pump Station at the new location. The supplemental boring and sounding locations are depicted in Figure 3.

Table 2 provides a summary of the northing, easting, elevation and depth of the supplemental rock core boring advanced in the footprint of the proposed Pump Station at its new location. The boring location was staked in the field by a representative of HDR and surveyed to determine the exact location of the boring. All measurements are expressed in feet and elevations are referenced to the North American Vertical Datum of 1988 (NAVD 88).

**Table 2 – Summary of Supplemental Rock Core Boring**

Boring No.	Northing <sup>(1)</sup>	Easting <sup>(1)</sup>	Surface Elev. (feet)	Top of Rock Elev. (feet)	Refusal / Begin Rock Core Elev. (feet)	Length of Rock Core (feet)	Boring Termination Depth (feet)	Bottom of Boring Elev. (feet)
PS-5	220292.347	1574785.766	923.64	917.64	917.64	50	56	867.64

Note:

- (1) Northing and Easting coordinates referenced to the North American Datum of 1983 and the Kentucky North state plane coordinate zone.

A summary of the northing, easting, elevations and depths of the two supplemental rock line soundings advanced at manholes MH-01 and MH-01B is included in Attachment B. The sounding locations were staked and surveyed in the field by a representative of HDR.

Horn performed the supplemental drilling and sampling operations on January 30, 2017. The drill crew advanced the soundings and boring utilizing 4.25-inch hollow-stem augers. Soil sampling was not performed within Boring PS-5. Rock coring was performed upon auger refusal within Boring PS-5 utilizing a NX size core barrel. Rock line soundings PS-6 and PS-7 were advanced to auger refusal or to a depth of 8 feet, depending on which occurred first.

## 5.0 SUBSURFACE CONDITIONS

### 5.1 Force Main Rock Line Soundings

Rock line soundings along the Force Main Sewer alignment indicate the depth to auger refusal is typically less than 8 feet. However, 19 of the soundings advanced along the alignment did not experience auger refusal prior to sounding termination at a depth of 8 feet. Auger refusal does not necessarily indicate the top of bedrock and refers to the refusal of a carbide tipped tooth auger bit. Auger refusal may indicate the presence of weathered bedrock, boulders, rock remnants or competent bedrock; however, an exact determination cannot be made without rock coring. Drilling operations along the alignment suggest the depth to auger refusal ranges from 2.0 feet to 8.0 feet (or El. 952.6 feet to 896.4 feet) below the existing ground surface.

### 5.2 Pump Station Sample Borings

The drilling and sampling operations performed near the location of the proposed pump station indicate the subsurface materials consist of thin (<8 feet) soil deposits. In general, the subsurface materials observed during the drilling operations primarily consist of a thin layer of topsoil and lean clay or silt extending to limestone bedrock with some shale lenses. Drilling operations in the area suggest the top of bedrock varies in elevation from approximately 918.6 feet to 915.2 feet.

**Topsoil** was encountered from the existing ground surface and extended to a depth of 0.6 feet below the ground surface within the initial four sample borings advanced at the project site. SPT samples were not advanced in topsoil and samples of the topsoil were not collected.

**Lean Clay, Silt (CL, ML)** was encountered at the existing ground surface and extended to depths that ranged from 4.8 feet to 7.6 feet (or El. 917.0 feet to El. 918.6 feet) below the ground surface. The thickness of the lean clay/silt ranged from 4.2 feet to 7.0 feet before encountering auger refusal or bedrock. The material was described as moist, light to dark brown, stiff to hard lean clay or silt. The uncorrected field blow counts for this soil layer ranged from 10 to 55 blows per foot (bpf), with an average of approximately 25 bpf. Split-Spoon sampler refusal, defined as 50 blows with less than 6 inches of sampler penetration, was experienced within this soil layer at Borings PS-1, PS-2 and PS-4. The average in-situ moisture content was 27.0 percent for this soil layer.

**Bedrock** was encountered at a depth of 5.0 feet (or El. 918.2 feet) below the existing ground surface within Boring PS-2 and at a depth of 6.0 feet (or El. 917.6 feet) below the ground surface within Boring PS-5. Auger refusal occurred within Borings PS-1, PS-3, PS-4, PS-6 and PS-7 at depths ranging from 4.8 feet to 7.6 feet (or El. 917.0 feet to El. 918.6 feet) and is anticipated to correspond to the depth to top of bedrock. The recovered rock core samples were described as slightly weathered to unweathered, moderately strong to strong, sub-rounded to sub-angular, and gray to light gray limestone with shale lenses. The bedrock was also described as slightly to moderately fractured and very fine to very coarse grained. Unconfined compression testing of representative rock resulted in a value of 6,278 pounds per square inch (psi) for a sample from PS-2.

**Groundwater** was not encountered within any of the sample borings at the time of drilling. However, fluctuations in the level of the groundwater may occur due to seasonal variations in precipitation and other factors not evident at the time of measurement.

## 6.0 LABORATORY TESTING AND RESULTS

The field boring logs were reviewed to estimate the depth and thickness of the soil and rock strata. A laboratory testing program was developed by HDR to evaluate the engineering properties of the recovered samples and to substantiate the visual soil classifications observed in the field. Laboratory testing of soil and bedrock samples obtained during the field exploration were conducted by HDR in

accordance with applicable American Society for Testing and Materials (ASTM) procedures for soil and rock testing. Selected soil specimens recovered during sampling operations were subjected to testing to determine the natural moisture content, soil classification and Atterberg limits, as applicable. A rock specimen recovered from Boring PS-2 during rock coring was subjected to unconfined compressive strength testing. HDR utilized the test results to establish material properties for the engineering foundation analyses. Laboratory test results and the typed boring logs for the SPT sample borings and rock core boring are included in Attachment C.

### 6.1 Classification Test Results for Cohesive Samples

Engineering classification testing was performed on selected soil specimens. The cohesive soils classify as CL and ML according to the Unified Soil Classification System (USCS).

### 6.2 Unconfined Compressive Strength Testing of Rock

One (1) rock core sample was tested for unconfined compressive strength for use in the foundation analyses. The sample was selected at an elevation near the proposed elevation of the Pump Station foundation. The result of the one unconfined compressive strength test performed was 6,278 psi. Rock Quality Designation (RQD) values ranged from 56% to 100% indicating a fair to excellent quality bedrock. The result of the unconfined compressive strength test performed on the rock core sample is presented in Table 3.

**Table 3 – Summary of Unconfined Compressive Strength Tests on Rock**

Boring No.	Northing	Easting	Sample Interval Elevation (feet)	Unconfined Compressive Strength (ksf)	Rock Type
PS-2	220379.001	1574804.512	880.5 – 880.9	904.0	Limestone

## 7.0 GEOLOGIC HAZARDS

The primary known geologic hazards in the vicinity of the project are mapped nearby faults and the potential for karst features.

### 7.1 Faults

Upon review of the interactive geologic map from the Kentucky Geological Survey (KGS) and the geologic map of The Lexington East Quadrangle, no faults are noted to be present within the immediate vicinity of the proposed project. The closest fault line is a normal fault belonging to the Georgetown-Gratz Fault System located approximately 0.1 miles north of the project. Other normal faults belonging to the Georgetown-Gratz Fault System are located at varying distances to the north and east of the proposed project site. In addition, a series of normal faults belonging to the Lexington Fault system are located approximately 3.7 miles southeast of the project site. The New Madrid Seismic Zone is located approximately 297 miles southwest of the project in eastern Missouri, northeast Arkansas, and parts of northwest Tennessee.

Only moderate earthquake activity has been experienced in Kentucky since the beginning of seismic records. Most of the seismic activity in Kentucky has occurred in the western part of the State, near the New Madrid Seismic Zone. In 2003, the town of Bardwell in western Kentucky (approximately 263 miles southwest of project site) recorded an earthquake with a VI intensity (Modified Mercalli Scale). Maysville, Kentucky (approximately 54 miles northeast of the project site) recorded an earthquake with a VII intensity (Modified Mercalli Scale) in 1980, which is the strongest recorded earthquake in Kentucky's seismic recording history. However, most notable of Kentucky's seismic activity originates in other states. The New Madrid Seismic Zone recorded several strong earthquakes during a period from 1811 to 1812.

The intensity of the largest of these earthquakes is estimated as XII. The New Madrid Fault is the most likely source for seismic events at the proposed structures.

## **7.2 Karst Features**

Upon review of the interactive map of Kentucky Karst Features from the Kentucky Geological Survey (KGS), the project area is located within a very high karst potential area in Fayette County. A karst potential map of the project site is included as Figure 5. KGS defines a very high karst potential area as an area underlain by thick-bedded, typically fine-grained and pure limestone units with little or no insoluble content. Very high karst potential areas will exhibit mature karst features, including caves, sinkholes, and springs where they crop out. Several mapped KGS sinkholes are located at varying distances around the perimeter of the proposed project limits. However, no mapped sinkholes are located within in the immediate vicinity of the proposed project. The nearest mapped sinkhole is approximately 1,400 feet south of the project site and occupies approximately 0.09 acres.

Karst features were not encountered during the subsurface investigation at the project site. However, rock line soundings were only advanced to a maximum depth of 8 feet below the existing ground surface and auger refusal was not experienced at nineteen sounding locations. Soundings advanced more than 8 feet may be necessary to determine if karst features are present at the aforementioned nineteen soundings. If conditions change during construction, HDR Inc. should be contacted to make additional recommendations.

Even with the use of borings, the lateral extent, depth and size of solution features in bedrock can still be difficult to estimate. It should be noted that significant changes in the loss of bedrock due to solutioning will most likely not occur over the life of the proposed structures; however, the potential for sinkhole development due to movement of overburden soils will change over time. Changes in groundwater flow, wetting/drying cycles, time and the effects of construction, along with other occurrences both natural and manmade, can result in sinkholes.

## **7.3 Corrosivity**

The risk of corrosion of concrete and steel were considered for the soils within the proposed project site. According to a customized soil report for the site from the Natural Resources Conservation Service (NRCS), the site is rated as a moderate to high risk of corrosion of uncoated steel and a low to moderate risk of corrosion of concrete.

## **8.0 ENGINEERING ANALYSES**

HDR has performed analyses for rock bearing foundation types only. The Preliminary Project Plans indicate that a combination of continuous spread footings and rectangular mat foundations are to be utilized as the foundation elements for the various proposed structures at the project site. This report provides recommendations for rock bearing foundation options for support of the proposed structures. The methods utilized in the design recommendations were developed by Kulhawy and Goodman (1987). A generalized soil profile is included as Attachment D to support in the design of the structures.

### **8.1 Seismic Design Considerations**

The American Society of Civil Engineers (ASCE) Standard SEI7-05, Minimum Design Loads for Buildings and Other Structures provides guidelines for determining the seismic hazard. The seismic hazard is characterized by the acceleration response spectrum and the site factors associated with the relevant site classification. Based on these guidelines and Table 20.3-1, the site classifies as a Site Class C for seismic design.

USGS probabilistic seismic hazard deaggregation plots (BC Rock) for return periods of 475, 975 and 2475 years are included in Attachment E. The peak ground accelerations for each return period are



provided in Table 4. These values should be scaled appropriately for the project Site Class C for seismic design.

**Table 4 – Peak Ground Accelerations**

Return Period (years)	Peak Ground Acceleration (g)
475	0.03
975	0.05
2475	0.09

## 8.2 Shallow Foundations

### 8.2.1 Bearing Capacity of Spread Footings / Mat Foundation

The Preliminary Project Plans and the drilling operations indicate that approximately 2.7 feet or less of soil is present from the top of bedrock to the bottom of the proposed footing at the loadout area, screenings room, odor control room, electrical room, and generator room. The Plans also indicate the proposed bottom of foundation elevation for the pump station, wet well, and valve vault are below the top of bedrock elevation. **Based on the shallow thickness of the overlying soils and the shallow soil depth from the top of bedrock to the bottom of proposed footing elevation, HDR recommends a foundation bearing in bedrock for the proposed structures.**

Foundations should be placed at a depth adequate enough to protect the foundations from the effects of frost. According to KBC (2013) Table 1809.5, for the project site, in Fayette County, the minimum depth for frost line protection is 24 inches (2 feet) below surface elevation. Therefore, a minimum foundation embedment depth of 2 feet below proposed final grade is recommended.

The drilling and laboratory testing program supported the engineering analyses required for continuous spread footings and mat foundations bearing on bedrock. The soil thickness ranges from approximately 4.8 feet to 7.6 feet before encountering competent bedrock or auger refusal at the project site. The underlying bedrock is described as limestone with shale. Unconfined compression testing was performed on one (1) rock core sample collected within Boring PS-2. Table 5 summarizes the recommended bearing elevations and the estimated allowable bearing capacity of continuous spread footings and rectangular mat foundations bearing on bedrock at the substructure locations.

**Table 5 – Recommendations for Spread Footings/Mat Foundation Bearing on Bedrock**

Rock Type	Top of Rock Elevation (feet) <sup>(1)</sup>	Bottom of Rock Layer Elevation (feet) <sup>(2)</sup>	Estimated Allowable Bearing Capacity (ksf)
Limestone w/ Shale Lenses	Varies	867.6	40

Note:

- (1) Top of bedrock elevation varies within each boring from approximately El. 915.2 feet to El. 918.6 feet.
- (2) Bottom of bedrock layer elevation based on the bottom of boring elevation at Boring PS-5.

The proposed project area is located within what KGS classifies as a very high karst potential area (see Section 7.2). KGS defines a very high karst potential area as an area underlain by thick-bedded, typically fine-grained and pure limestone units with little or no insoluble content. In addition, several mapped KGS sinkholes are located at varying distances around the perimeter of the proposed project limits. Karst topography could result in an uneven and undulating top of bedrock that can result in highly variable top

of bedrock elevations and inconsistent bearing conditions over a very short distance. However, karst features were not encountered during the subsurface investigation at the project site. If conditions change during construction, HDR Inc. should be contacted to make additional recommendations.

### **8.2.2 Settlement of Possible Spread Footings**

Settlement for continuous spread footings or mat foundations bearing on bedrock are considered negligible.

### **8.2.3 Construction Considerations**

The foundation design recommendations are based on a requirement for field observations of foundation installation. The geotechnical engineer of record or his/her representative should be present to observe the excavation, examine the bottom of each excavation, and determine if conditions within the excavation are consistent with those identified in the site explorations and that the subgrade material along the base of the excavation appears adequate for the design bearing pressure. If inadequate bearing material is present at the design bearing elevation, the footing should be widened or deepened as directed by the project geotechnical engineer until adequate bearing is reached. Records should be kept to document observations and record quantities.

The estimated continuous spread footing and mat foundation bearing elevations are based on visual examinations of recovered rock core and supplemental sample boring information. Final bearing elevations of selected foundation systems may vary at locations where rock cores or sample borings were not performed. The bearing surfaces of spread footings or mat foundations should be level, and free of loose, soft or excessively wet material. Additional rock excavations may be required within the footprint of each footing to achieve level surfaces. Soft compressible materials should be removed prior to placement of reinforcing steel and concrete.

The rock surface should be dry when concrete is placed or the water in the excavations properly controlled during concrete placement. If there is 1 inch or less of water, which cannot be practically removed, about 3 inches of dry concrete mortar with extra cement should be placed in the excavation prior to placing concrete. If there is more than 1 inch of water in the excavation, a small sump should be excavated from which excess water should be bailed or pumped. If pumping is utilized to maintain the water level in the excavation, the pump should be operated until immediately prior to concrete placement.

## **9.0 RECOMMENDATIONS FOR CONSTRUCTION**

### **9.1 Below Grade Walls**

The below grade concrete walls of the Screenings Room, Pump Station, Wet Well and Valve Vault should be backfilled with clean gravel material (e.g. ASTM C33 -No. 57, -No. 67, or -No. 8 stone). The gravel material should be placed in even lifts not exceeding 8 inches in loose thickness and vibrated to a density greater than or equal to 95 percent of the maximum dry density, as determined by the Standard Proctor Test, ASTM D698.

The compaction effort should be controlled during backfill operation. Over-compaction can produce excessive lateral earth pressures. Compaction levels adjacent to below-grade walls should be maintained between 95 and 100 percent of the maximum dry density, as determined by the Standard Proctor Test, ASTM D698.

The lateral earth pressure distribution on below-grade walls may be determined using the following equivalent fluid unit weights:

For soils above any free water surface, recommended equivalent fluid pressures are:

- Active:
  - Cohesionless soil backfill (stone) 35 psf/ft
  - Cohesive soil backfill (clay) 45 psf/ft
- Passive:
  - Cohesionless soil backfill (stone) 375 psf/ft
  - Cohesive soil backfill (clay) 330 psf/ft
- At-rest:
  - Cohesionless soil backfill (stone) 55 psf/ft
  - Cohesive soil backfill (clay) 65 psf/ft

The following soil strengths were utilized to estimate the equivalent fluid pressures:

	Total Unit Weight	Angle of Internal Friction
Cohesionless soil backfill (stone)	115 pcf	32 degrees
Cohesive soil backfill (clay)	120 pcf	28 degrees

The lateral earth pressures do not include any factor of safety and are not applicable for hydrostatic loading. It should be noted that the equivalent fluid pressures indicated above assume that the existing fill or imported fill is compacted and tested in accordance with Section 9.5 of this report. Additional recommendations may be necessary if submerged conditions are to be included.

The above values do not include a ground level surcharge component. The effect of surcharge loads, where applicable, should be incorporated into the wall pressure diagram by adding a pressure component equal to the 0.50 times the surcharge load to the full height of the wall.

A drain is recommended for the wall to collect and remove water that has migrated or percolated behind the wall(s). If used, the lower equivalent fluid pressure (drained) may be used for design purposes.

## 9.2 Site Preparation and Excavations

In preparing the site for construction, all topsoil and any other deleterious materials should be completely removed from the construction area and any other areas which are to be cut or receive fill. After clearing and stripping is complete, the area should be checked by a representative of the project geotechnical engineer to determine that the clearing and stripping has been sufficient to remove the topsoil and vegetation. Excavations resulting from clearing should be backfilled in accordance with the grading recommendations for the site. Provisions should be made both during and after grading, to protect exposed earthwork construction areas and earth slopes from erosion as required by the project civil engineer and by applicable Federal, State, and local regulations.

## 9.3 Temporary Construction Excavations

All temporary construction excavations (such as those required for footings, utility trenches, etc.) should be constructed in accordance with OSHA regulations. All excavations should be evaluated and classified by a competent person. Near surface soils in the boring generally classify as OSHA Type B. Excavations extending into Type B soils should be cut on a slope no steeper than 1 horizontal (H) to 1 vertical (V).

Flatter slopes may be required and all operations should be performed under the supervision of qualified site personnel in accordance with OSHA regulations.

Temporary shoring should be designed in accordance with OSHA guidelines for temporary shoring and must meet OSHA requirements as a minimum. Exposed excavation slopes should be protected from erosion and saturation by rainfall and runoff using berms, diversion ditches, and/or plastic sheeting. Caution should still be exercised as slopes cut in accordance with OSHA regulations may still experience sloughing, raveling, and sliding which may necessitate the use of flatter slopes. Adequately designed bracing may also be used or required to support excavations next to existing structures.

Soil removed from excavations should not be stockpiled next to cut slopes. A minimum setback equal to the depth of the excavation should be maintained between the top of the cut slope and the toe of the soil stockpile.

## **9.4 Fill and Backfill Material**

### **9.4.1 On-site Soils**

On site soils are mostly lean clays (CL) and silts (ML) and are suitable for use as structural fill and backfill. However, there may not be enough quantity of soils for use as structural fill and backfill.

### **9.4.2 Off-Site Materials**

Fill materials should be approved by the geotechnical engineer before placement. Satisfactory soil materials for structural fill are defined as those complying with ASTM D2487 classification groups GW, GP, and GM for crushed stone and gravel; SM, SW, and SP for sand; and CL and ML for lean clay and silt. Unsatisfactory soils include those complying with ASTM D2487 soil classification groups MH, CH, OL, OH, and Peat. Samples of the proposed fill material should be provided to the geotechnical engineer for laboratory determination of Proctor density and moisture values, and Atterberg limit or other index tests required for classification.

Contractors should allow about one week for the time required to complete the laboratory tests in accordance with ASTM requirements.

In general, fill should not include any rocks or rubble larger than 6 inches in diameter. Larger sizes may be approved by the geotechnical engineer. Fill should not contain any significant amounts of organics or debris. Material other than soil, sand and gravel should be considered deleterious material unless the geotechnical engineer states otherwise after visual inspection of the material. Deleterious material should not be used in site fills, regardless of whether it is from an on-site source or delivered to the site. Deleterious material will include organic matter, wood, metal, plastic, and trash.

## **9.5 Fill Compaction and Placement Criteria**

### **9.5.1 Percent Compaction and Moisture Control**

Embankments and backfills of less than 3 feet of fill should be compacted to at least 95 percent of the dry density as determined by the Standard Proctor Test, ASTM D 698. When embankments and backfills are composed of more than 3 feet of fill, the materials within 3 feet of the top of fill subgrade elevation should be compacted to a minimum of 95 percent of the dry density as determined by the Standard Proctor Test with material below the 3 feet of the top of fill subgrade elevation compacted to a minimum of 90 percent of the dry density as determined by the Standard Proctor Test.

Before compaction, the moisture content of fill materials should be controlled by discing and drying or adding water sufficient to achieve the specified compaction. The moisture content of fill materials should

be controlled within -2 percent to +3 percent of the optimum water content as determined by the Standard Proctor Test.

#### **9.5.2 Lift Thickness and Placement**

Soil fill should be placed in lifts 8 inches or less in loose thickness for machine compactors and 4 inches or less in loose thickness for hand compactors. Thicker lifts should only be used with the permission of the geotechnical engineer and only when test data supports that adequate compaction of the fill is achieved.

The surface of compacted subgrade soil can deteriorate and lose its support capabilities when exposed to environmental changes and construction activity. Subgrade that have deteriorated or softened should be scarified and recompacted immediately prior to placement of additional materials. Compaction of subgrade surfaces, fill and backfill should be verified with a sufficient number of density tests to assure that adequate compaction is being achieved.

Fill placement and proof rolling of the exposed subgrade should be monitored by HDR or the project geotechnical engineer to verify that unstable materials are not present and that proper placement and compaction of materials has been accomplished. Exposed subgrade surfaces should be systematically proof rolled before placement of structural fill. Compaction of rock fill and other fill that will be subject to performance criteria should be observed by the geotechnical engineer.

Construction specifications should require at least one in-place density test of the compacted fill for every 5,000 square feet of fill placed. For backfill of utility trenches or around structures, construction specifications should require at least one in-place density test per lift for every 100 feet of trench, or fraction thereof. At least one test should be completed per lift regardless of the size or location of the fill area.

#### **9.6 Control of Surface Water and Runoff**

The control of surface runoff will be necessary to prevent and control erosion of exposed soils, especially on slopes, and the softening of exposed subgrades in excavations. Surficial drainage of slopes, berms, ditches, trench drains, and pumping from sumps should be used as needed to readily remove any surface water. A drainage plan to collect and control the flow of surface runoff around the construction area should be carefully thought out and implemented before site grading begins. Throughout the duration of construction, the drainage plan should be periodically reviewed and modified as needed.

#### **9.7 Construction Monitoring Requirements**

Geotechnical observation and testing is considered a continuation of this evaluation that should be conducted by a professional geotechnical engineer to evaluate geotechnical aspects of construction. As the geotechnical engineering firm that performed the geotechnical evaluation for this project, HDR should be retained to confirm that the recommendations of this report are properly incorporated in the design of this project, and properly implemented during construction. These services provide HDR the opportunity to observe the actual conditions encountered during construction and to evaluate the applicability of the recommendations presented in this report to the site conditions. HDR cannot be responsible for interpretation by others of this report or the conditions encountered in the field.

A representative of HDR, Inc. should review the project plans and specifications, including any revisions or modifications. Additionally, a representative from our firm should observe that engineering conditions are as anticipated in the project design, including as outlined in the plans and specifications.

Installation of the foundations systems should be monitored by an experienced and qualified geotechnical engineer familiar with the subsurface conditions at the project site. Construction observations should confirm that the subsurface and bedrock conditions during construction are similar to those outlined in this report.

If changed site conditions affect the recommendations presented herein, HDR must also be retained to perform a supplemental evaluation and to issue a revision to our original report.

## 10.0 LIMITATIONS

This report presents our findings, recommendations and considerations for design and construction of the foundation system for the proposed Lexington Fayette Urban County Government (LFUCG) Expansion Area 3 (EA3) Pump Station and Force Main. It has been prepared in accordance with generally accepted engineering practice and in a manner consistent with the level of care and skill for this type of project within this geographic area. No warranty, expressed or implied, is made.

The conclusions and recommendations presented herein are based on field reconnaissance, research and available literature, the results of field exploration and laboratory materials testing, and the results of engineering analyses. HDR should be immediately contacted should subsurface conditions be encountered that are materially different than those identified at the boring locations. Subsurface conditions that are materially different may require further investigation and supplemental recommendations.

Geotechnical engineering and the geologic sciences are characterized by uncertainty. Professional judgments presented herein are based partly on our understanding of the proposed construction, partly on our general experience, and on the state-of-the-practice at the time of this writing.

## 11.0 REFERENCES

- ASCE (2006), "Minimum Design Loads for Buildings and Other Structures", American Society of Civil Engineers, 2006.
- Das (1997), Das, B.M. "Advanced Soil Mechanics, 2<sup>nd</sup> Edition," 1997.
- FHWA (1993), "Soils and Foundations Workshop Manual, 2<sup>nd</sup> Edition, Publication No. FHWA HI-88-009", Federal Highway Administration, July 1993.
- FHWA (1997), "Training Course in Geotechnical & Foundation Engineering, Publication No. FHWA HI-97-021", Federal Highway Administration, 1997.
- KBC (2013), "The Kentucky Building Code", Tenth Edition, Department of Housing, Buildings, and Construction. June 2013.
- KGS (1968), "Geologic Map of the Lexington East Quadrangle, Fayette and Bourbon Counties, Kentucky", by W.C. MacQuown, Jr. and E. Dobrovolny, published by Kentucky Geological Survey, 1968.
- KGS (1978), "Topography of Kentucky", by P. McGrain and J. Currens, Kentucky Geological Survey, 1978.
- KGS (2002), "Karst Occurrence in Kentucky", published by Kentucky Geological Survey, 2002.
- KGS (2016), Geologic Map Information Service, Karst Potential and Standard Geologic Maps, <http://kgs.uky.edu/kgsmmap/kgsgserver/viewer.asp> (Accessed 10-19-16)
- Kulhawy & Goodman (1987), Kulhawy, F.H. and R.E. Goodman, 1987. "Foundations in Rock," In Ground Engineering Reference Manual, F.G. bell, ed. Butterworths Publishing Company, London, Chapter 55.

NAVFAC (1986), Naval Facilities Engineering Command, "Design Manual-7.02, Foundations and Earth Structures, September 1986.

OSHA (2016), "Safety and Health Regulations for Construction, 1926 Subpart P App P", Occupational and Health Regulations for Construction

Tomlinson, M.J. (1986), "Foundation Design and Construction, Fifth Edition", Longman Scientific and Technical, London.

Tomlinson, M.J. (1980), "Foundation Design and Construction, Fourth Edition", Pitman Publishing Limited, 128 Long Acre, London WC2E 9AN UK.

USACE (1990), United States Army Corps of Engineers, "Engineer Manual EM 1110-1-1904," 1990.

USDA (2016), Web Soil Survey, United States Department of Agriculture Natural Resource Conservation Service, 2016, <http://websoilsurvey.nrcs.usda.gov/app/> (Accessed 10-19-16)

USGS (2008), 2008 Interactive Deaggregations,  
<https://geohazards.usgs.gov/deaggint/2008/index.php> (Accessed 10-19-16)

USGS (2016), Earthquake Hazard Program, United States Geological Survey, 2016,  
<http://earthquake.usgs.gov/>

**PAGE LEFT INTENTIONALLY BLANK**



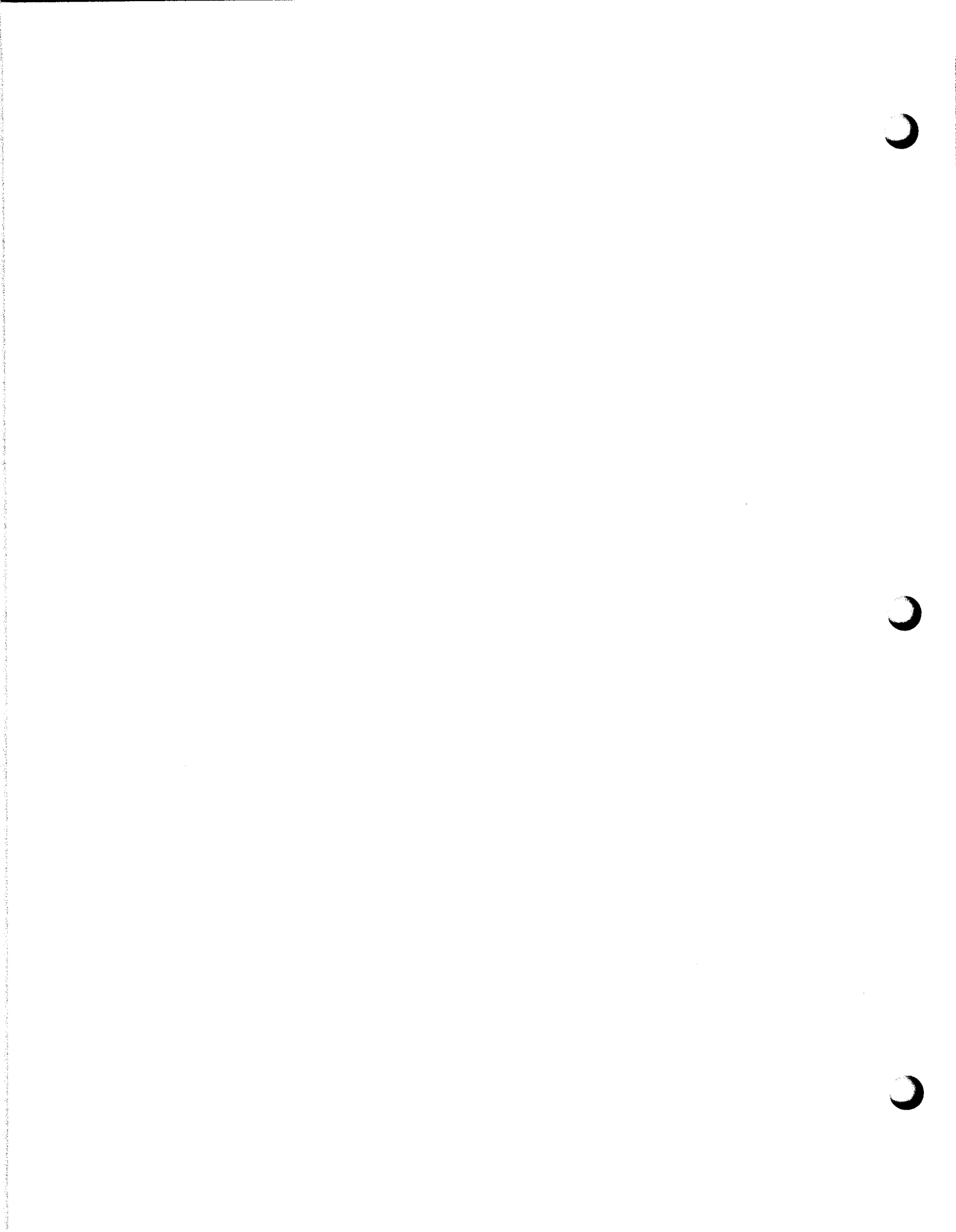

**FIGURES**

---





**LEGEND**

 Proposed EAS Fossil Main  
 Proposed Pump Station Site  
 Proposed Access Road (20 feet)  
 DRAWN TO SCALE (EAS FOSSEAL MAIN)  
 DATE: 10/04/16

Prepared by:



Prepared for:



# Project Location Map

Project: Lower Cane Run LFCUG EA3 PS & FM  
 Project No: 10041433  
 Location: Fayette County, Kentucky  
 Approved: TCB  
 Drawn By: BAR  
 Date: 10/04/16  
 Rev. Date: 10/21/16  
 Scale: As Shown  
 Figure No. 1

# Kentucky Geologic Map Information Service

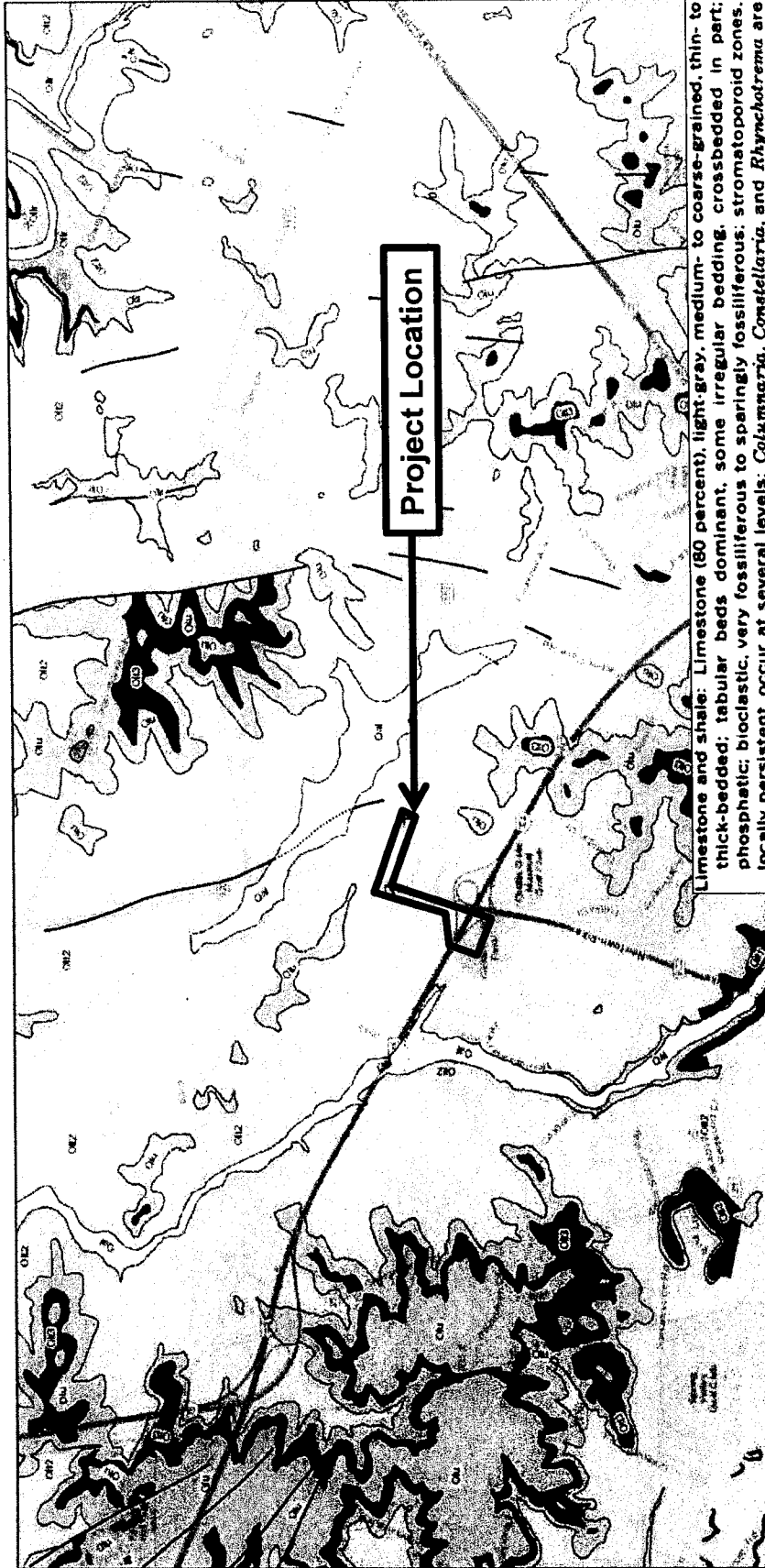

**Project Location**

Limestone and shale: Limestone (80 percent), light gray, medium- to coarse-grained, thin- to thick-bedded; tabular beds dominant, some irregular bedding, crossbedded in part; phosphatic; bioclastic, very fossiliferous to sparingly fossiliferous; stromatoporoid zones, locally persistent, occur at several levels; *Columnaria*, *Conostellaria*, and *Rhynchotrema* are

1:36,112  
 0 0.45 0.9 1.8 mi  
 0 0.5 1 2 km

Sources: Esu, HEBE, Dalome, Inesme, incement, P. Corp., GEBCO, USGS, FAO, NPS, NRCAN, Geobase, IGN, Karlsruhe NL Ordnance Survey, Esri Japan, METI, Esri China (Hong Kong), Swisstopo, MapboxIndia, © OpenStreetMap contributors, and the GIS User Community

author: Kentucky Geological Survey  
 copyright: Kentucky Geological Survey

Lower part of Lexington Limestone (Lower Ordovician - Middle Ordovician)

Alluvium (Quaternary - Quaternary)

Upper part of Lexington Limestone (Lower Ordovician - Middle Ordovician)

Tanglewood Limestone Member (3) (Lower Ordovician - Middle Ordovician)

Tanglewood Limestone Member (2) (Lower Ordovician - Middle Ordovician)

October 4, 2016

Project: Lower Cane Run LFUCG EA3 PS & FM  
 Project No: 10041433  
 Location: Fayette County, Kentucky  
 Approved: TCB  
 Drawn By: BAR  
 Date: 10/04/16

Rev. Date: 10/21/16  
 Scale: As Shown  
 Figure No: ?

# Bedrock Geology Map

Prepared by:

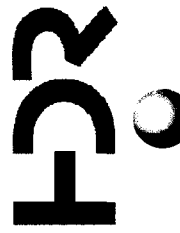

Prepared for:

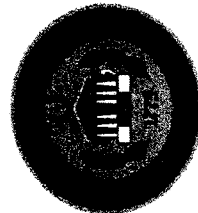

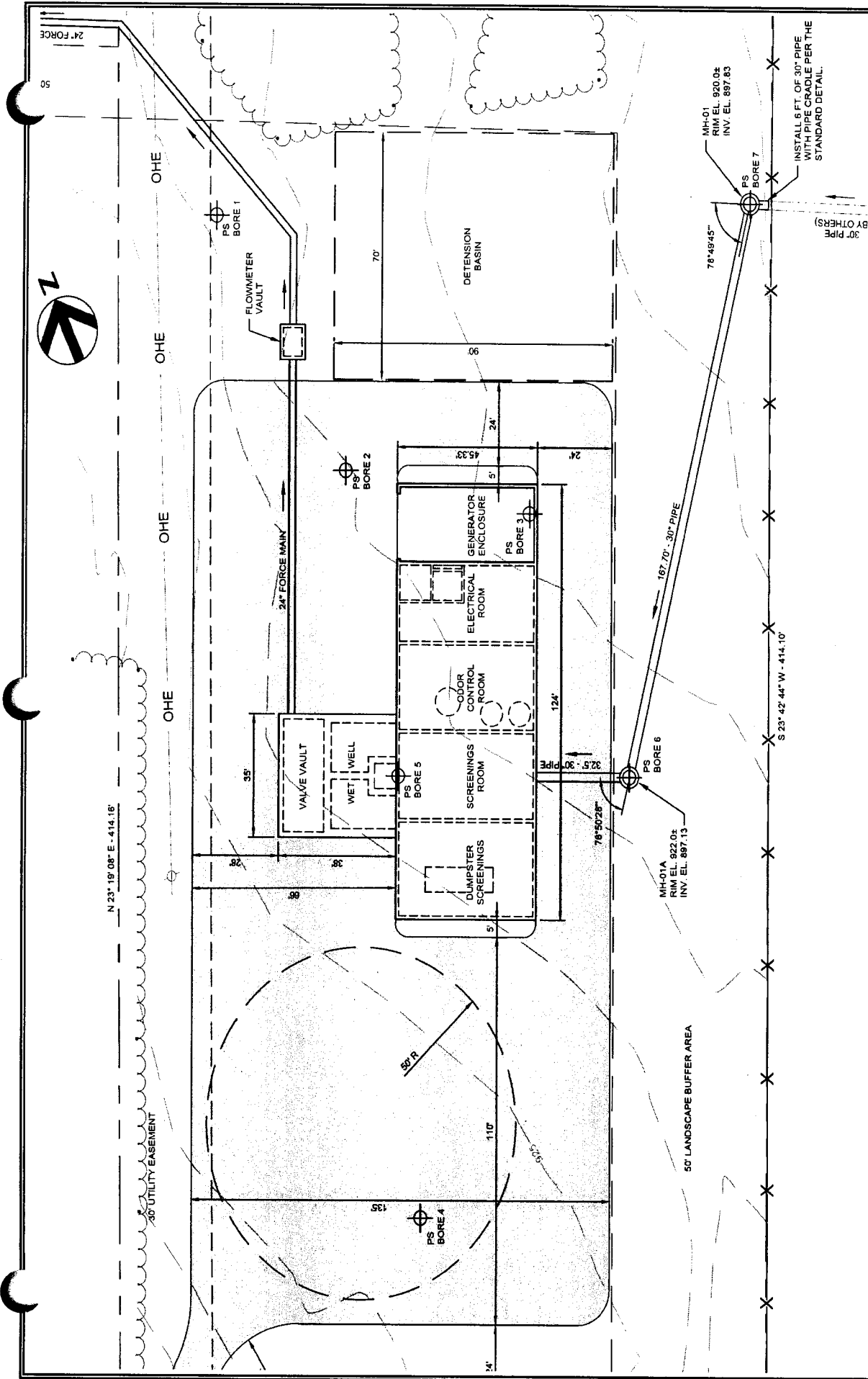

Project: Lower Cane Run LFUCG EA3 PS & FM  
 Project No: 10041433  
 Location: Fayette County, Kentucky  
 Approved: TCB  
 Drawn By: BAR  
 Date: 10/04/16

Rev. Date: 10/21/16  
 Scale: NTS  
 Figure No. 3

# Boring Location Map

Prepared for:

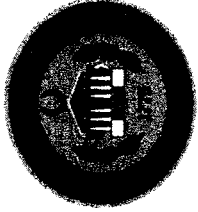

Prepared by:





Soundings obtained every 50 feet along the force main alignment, proceeding from Sounding FM-1 to Sounding FM-103.

Project: Lower Cane Run LFUCG EA3 PS & FM  
 Project No: 10041433  
 Location: Fayette County, Kentucky  
 Approved: TCB  
 Drawn By: BAR  
 Date: 10/04/16  
 Rev. Date: 10/21/16  
 Scale: As Shown  
 Figure No. 4

# Sounding Location Map

**LEGEND**

- Proposed EA3 Force Main
- Proposed Pump Station Site
- Proposed Access Rd (20 feet)

DATA SOURCE: LFUCG, KY APED Imagery 2012

0 100 200 Feet

LEGATION OF LIABILITY: THE ARCHITECTS ENGINEERS AND SURVEYORS OF THE STATE OF KENTUCKY, INC. (AES) HAS PREPARED THIS SOUNDING LOCATION MAP FOR THE PROJECT AND HAS CONDUCTED THE FIELD SURVEY AND DATA COLLECTION. THE CLIENT HAS REVIEWED AND APPROVED THE DATA COLLECTION AND THE PREPARATION OF THIS SOUNDING LOCATION MAP. THE CLIENT HAS REVIEWED AND APPROVED THE DATA COLLECTION AND THE PREPARATION OF THIS SOUNDING LOCATION MAP.

Prepared by: **HDR**

Prepared for: 







ATTACHMENT A: Preliminary Project Plans

---



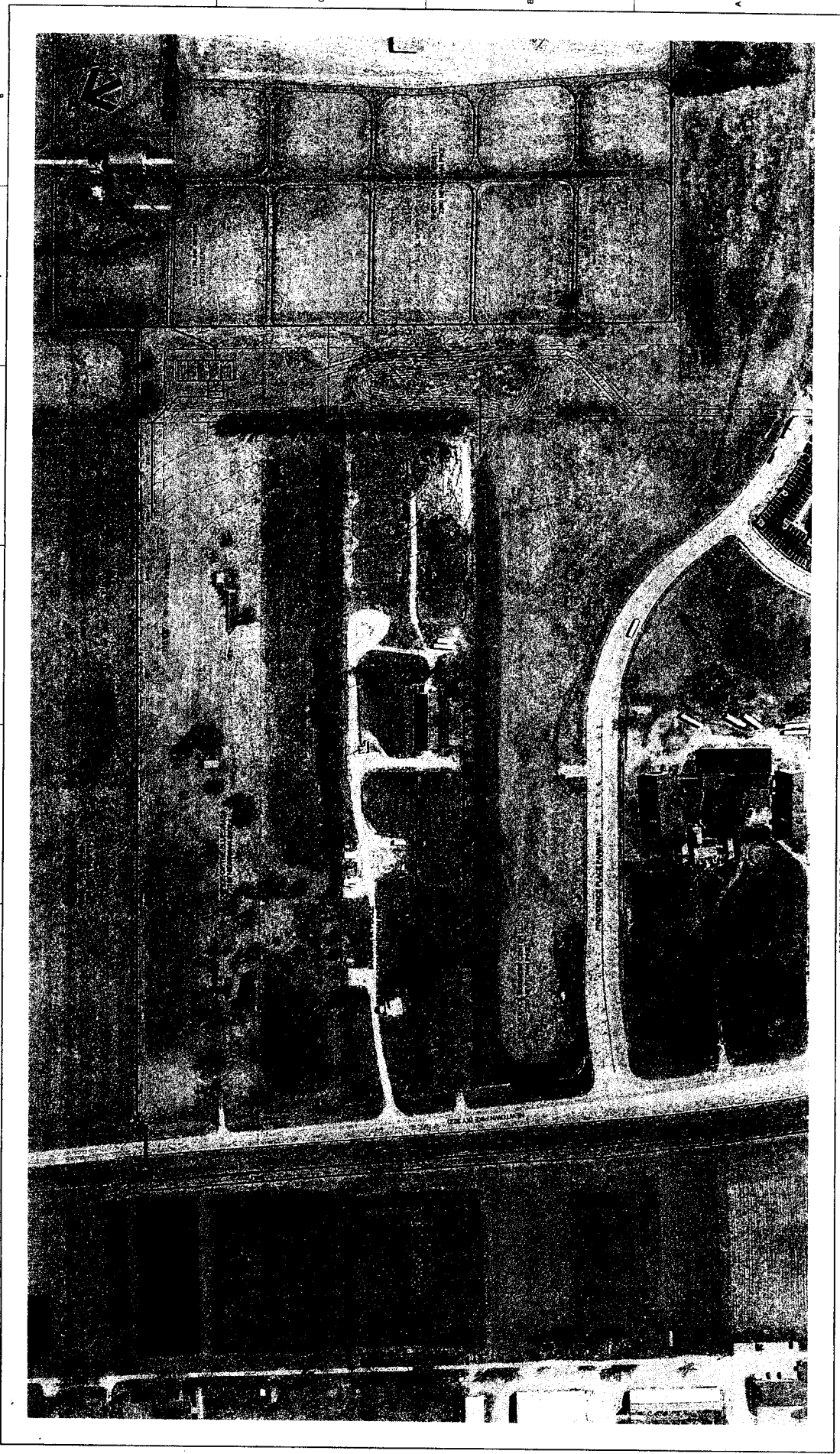

OVERALL SITE PLAN

FILENAME: 01C-01  
SCALE: 1" = 100'

EXPANSION AREA 3  
PUMP STATION AND FORCE MAIN  
IMPROVEMENTS



PRELIMINARY  
NOT FOR  
CONSTRUCTION OR  
RECORDING

PROJECT MANAGER: D. BURTON HANSON

DESIGNED	
DRAWN	
CHECKED	
DATE	
PROJECT NUMBER	10N-433

REV	DATE	DESCRIPTION



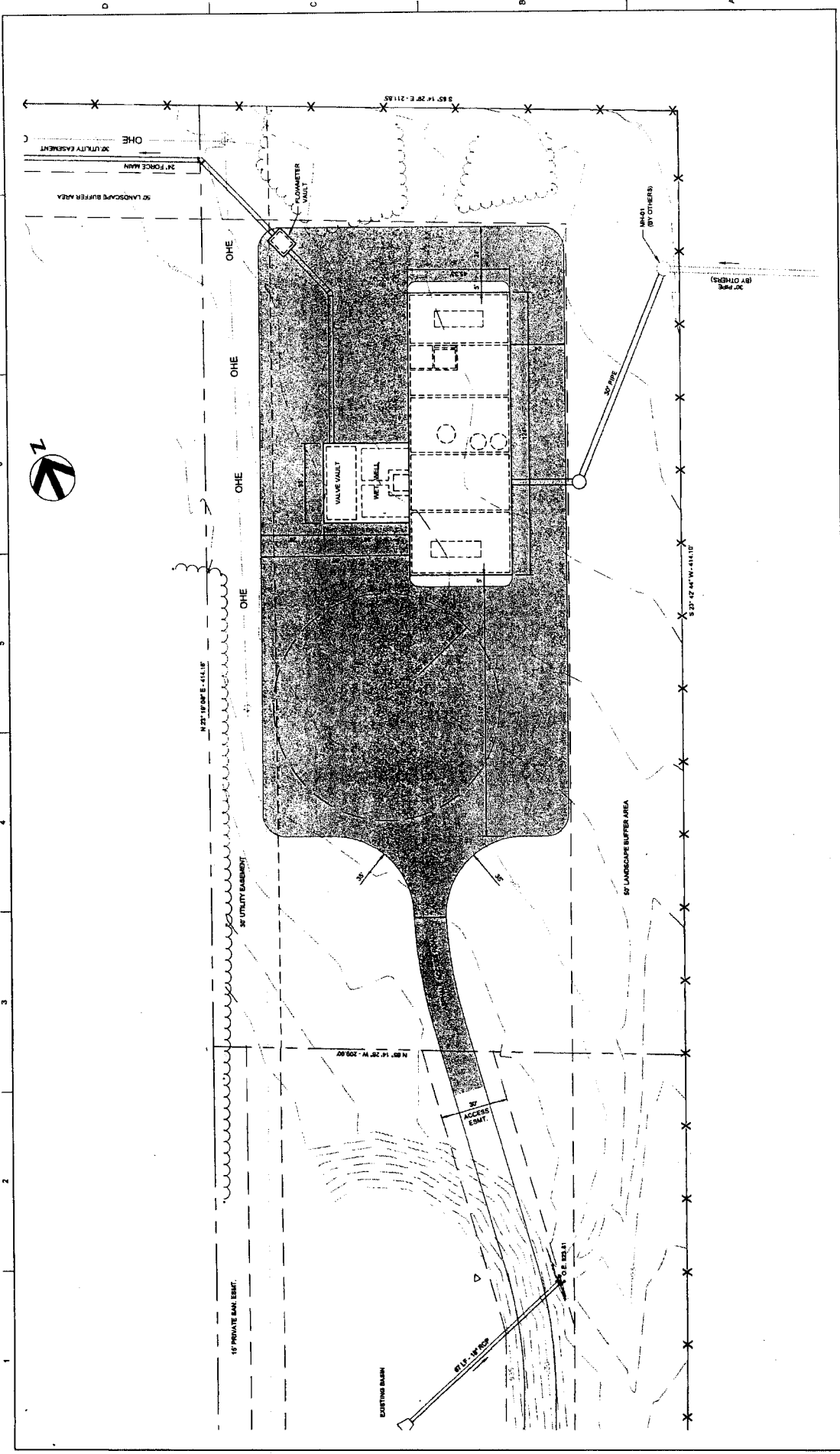

**SITE LAYOUT PLAN**

PROJECT NUMBER: 10011433  
 FILE NAME: 01C-02  
 SCALE: 1" = 20'

**EXPANSION AREA 3  
 PUMP STATION AND FORCE MAIN  
 IMPROVEMENTS**

**PRELIMINARY  
 NOT FOR  
 CONSTRUCTION OR  
 RECORDING**

PROJECT MANAGER: P. BENSON HANSON

DESIGNED	
DRAWN	
CHECKED	
DATE	
PROJECT NUMBER	10011433

ISSUE	DATE	DESCRIPTION

**HDR**

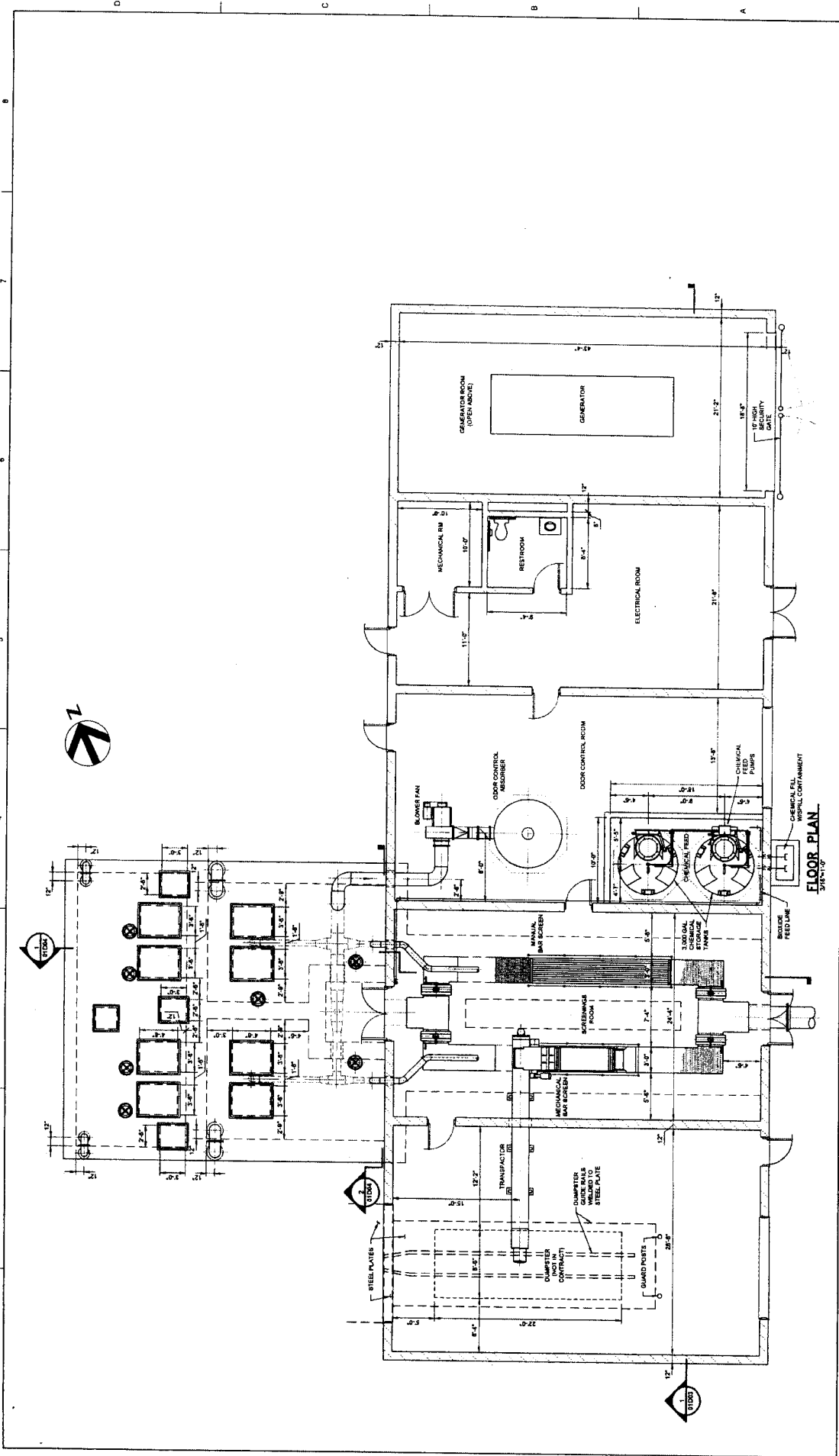

PUMP STATION  
UPPER FLOOR PLAN

EXPANSION AREA 3  
PUMP STATION AND FORCE MAIN  
IMPROVEMENTS



PRELIMINARY  
NOT FOR  
CONSTRUCTION OR  
RECORDING

PROJECT MANAGER	BOBSON JAMISON
DRAWN	
CHECKED	CLAUDE
DATE	
PROJECT NUMBER	1001433

**FOR**

SHEET 01

SCALE 3/8" = 1'-0"



REV	DATE	DESCRIPTION

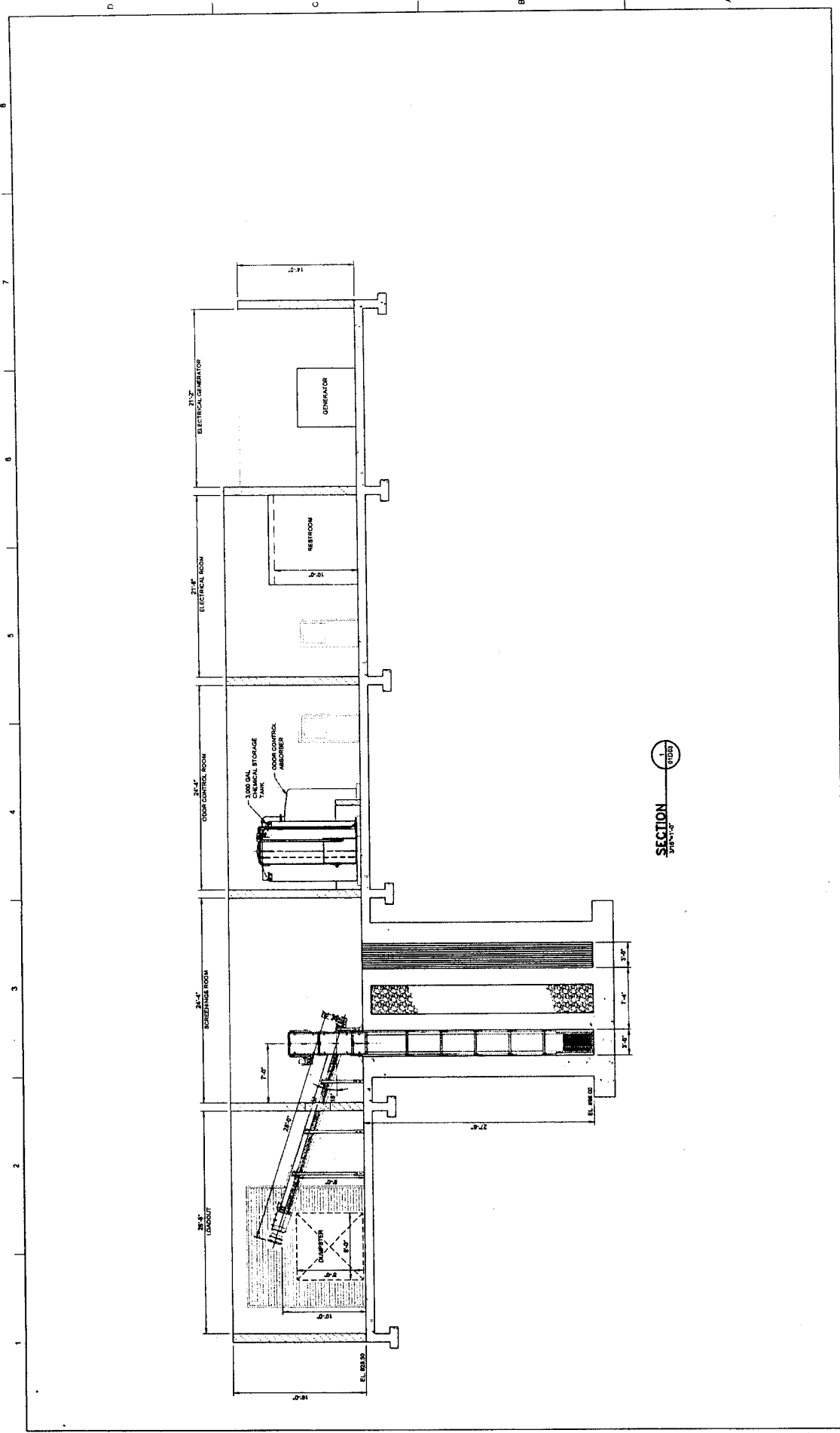

PUMP STATION SECTION  
 SHEET 01D-03  
 PLANNER CD-02  
 SCALE 3/16" = 1'-0"

EXPANSION AREA 3  
 PUMP STATION AND FORCE MAIN  
 IMPROVEMENTS

PRELIMINARY  
 NOT FOR  
 CONSTRUCTION OR  
 RECORDING

PROJECT MANAGER P. BENTON HOBSON

DESIGNED	DATE
CHECKED	DATE
DRAWN	DATE
PROJECT NUMBER	10011513

ISSUE	DATE	DESCRIPTION



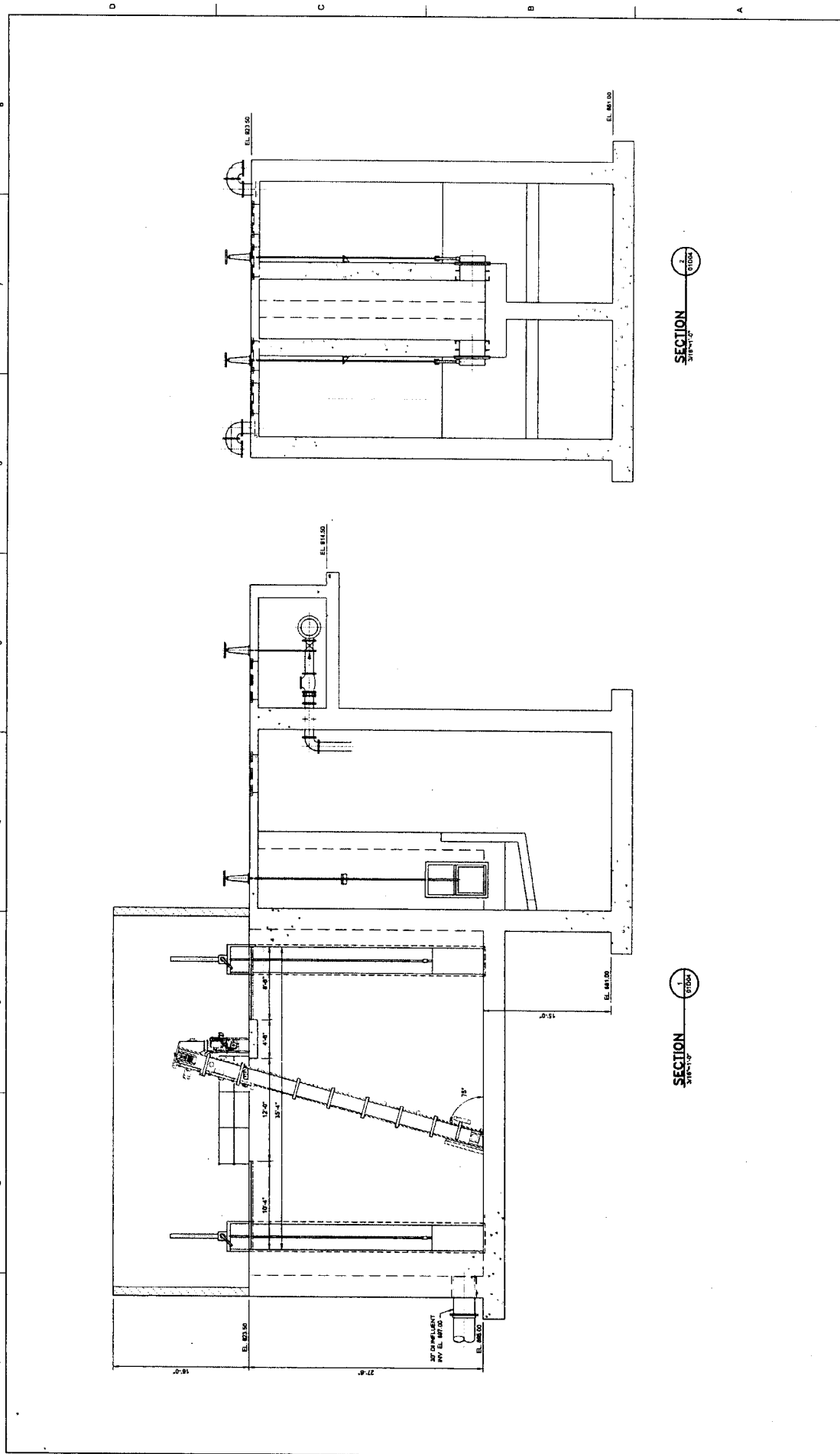

SECTION 2  
3/16" = 1'-0"

SECTION 1  
3/16" = 1'-0"

PUMP STATION SECTIONS

EXPANSION AREA 3  
PUMP STATION AND FORCE MAIN  
IMPROVEMENTS



PRELIMINARY  
NOT FOR  
CONSTRUCTION OR  
RECORDING

PROJECT MANAGER P. HENTON HANSON

DESIGNED

DRAWN

CHECKED

DATE

PROJECT NUMBER

1001153

SCALE

DATE

DESCRIPTION



SHEET 01D-04

FILENAME: 01D-04  
SCALE: 3/16" = 1'-0"



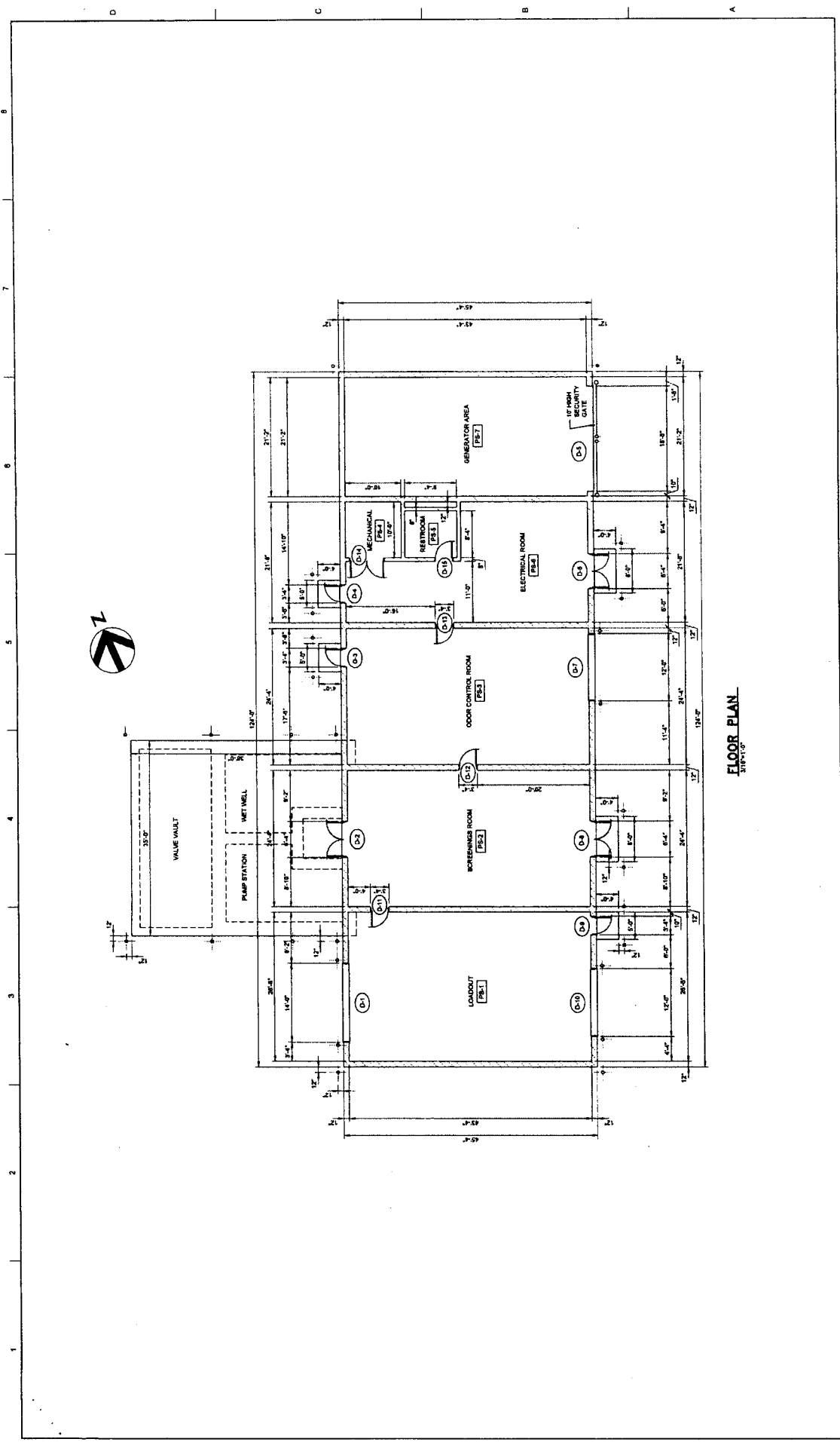

FLOOR PLAN  
3/18/13

PROJECT MANAGER P. BENTON HINCHEN  
 DESIGNED BY [ ]  
 DRAWN BY [ ]  
 CHECKED BY [ ]  
 DATE [ ]  
 PROJECT NUMBER 1001153

NO.	DATE	DESCRIPTION

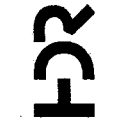

PRELIMINARY  
 NOT FOR  
 CONSTRUCTION OR  
 RECORDING



EXPANSION AREA 3  
 PUMP STATION AND FORCE MAIN  
 IMPROVEMENTS

BUILDING FLOOR PLAN

SHEET 01A-01  
 FILENAME 01A-01  
 SCALE 1/8" = 1'-0"



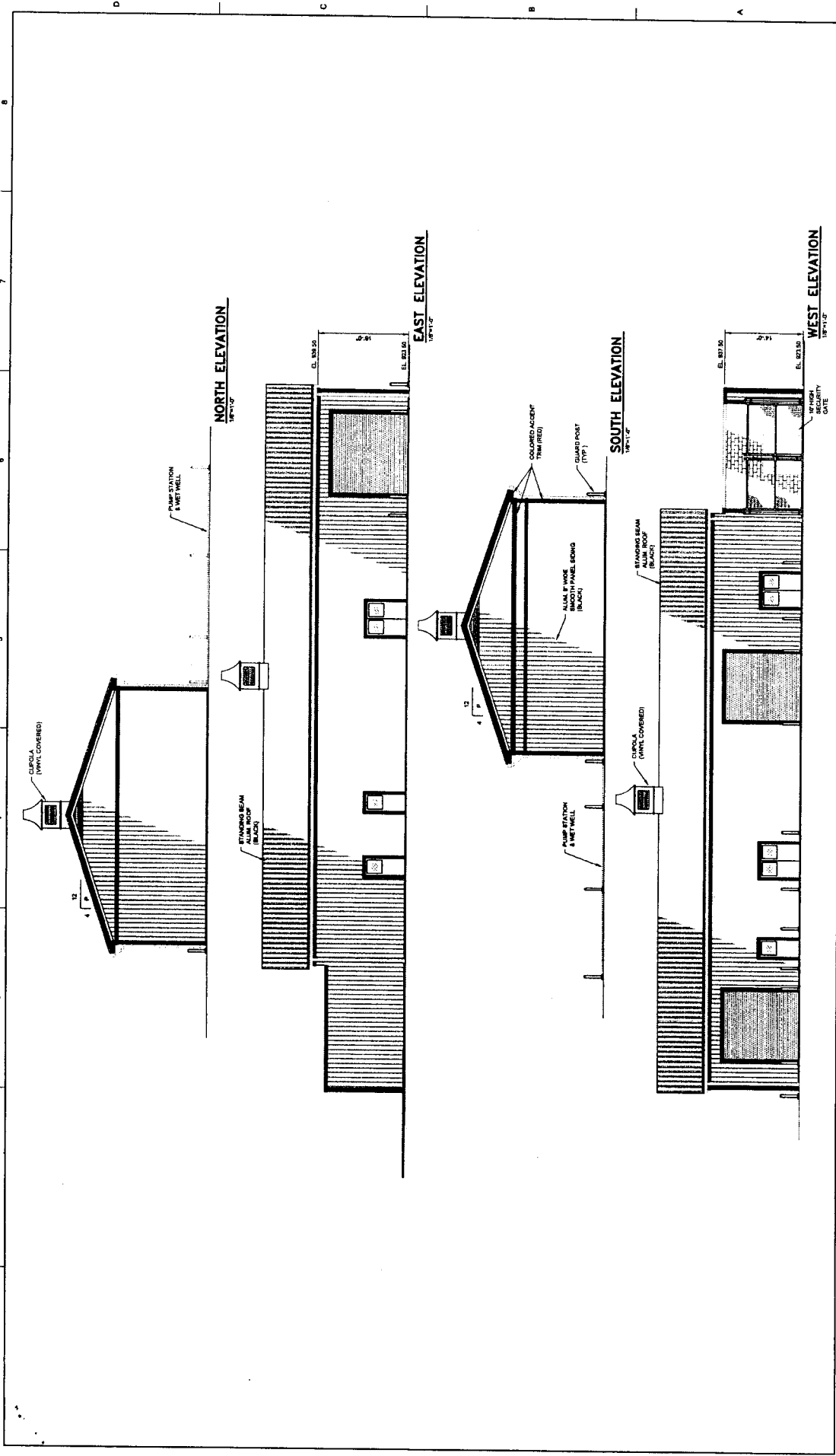

**BUILDING ELEVATIONS**

**EXPANSION AREA 3  
PUMP STATION AND FORCE MAIN  
IMPROVEMENTS**

**PRELIMINARY  
NOT FOR  
CONSTRUCTION OR  
RECORDING**

PROJECT MANAGER: J. BENTON HANCOCK

DESIGNED	DATE
DRAWN	DATE
CHECKED	DATE
IN CHARGE	DATE

PROJECT NUMBER: 1001133

DATE	DESCRIPTION



SHEET  
**01A-02**

FILENAME: 01A-02  
SCALE: 1/8" = 1'-0"



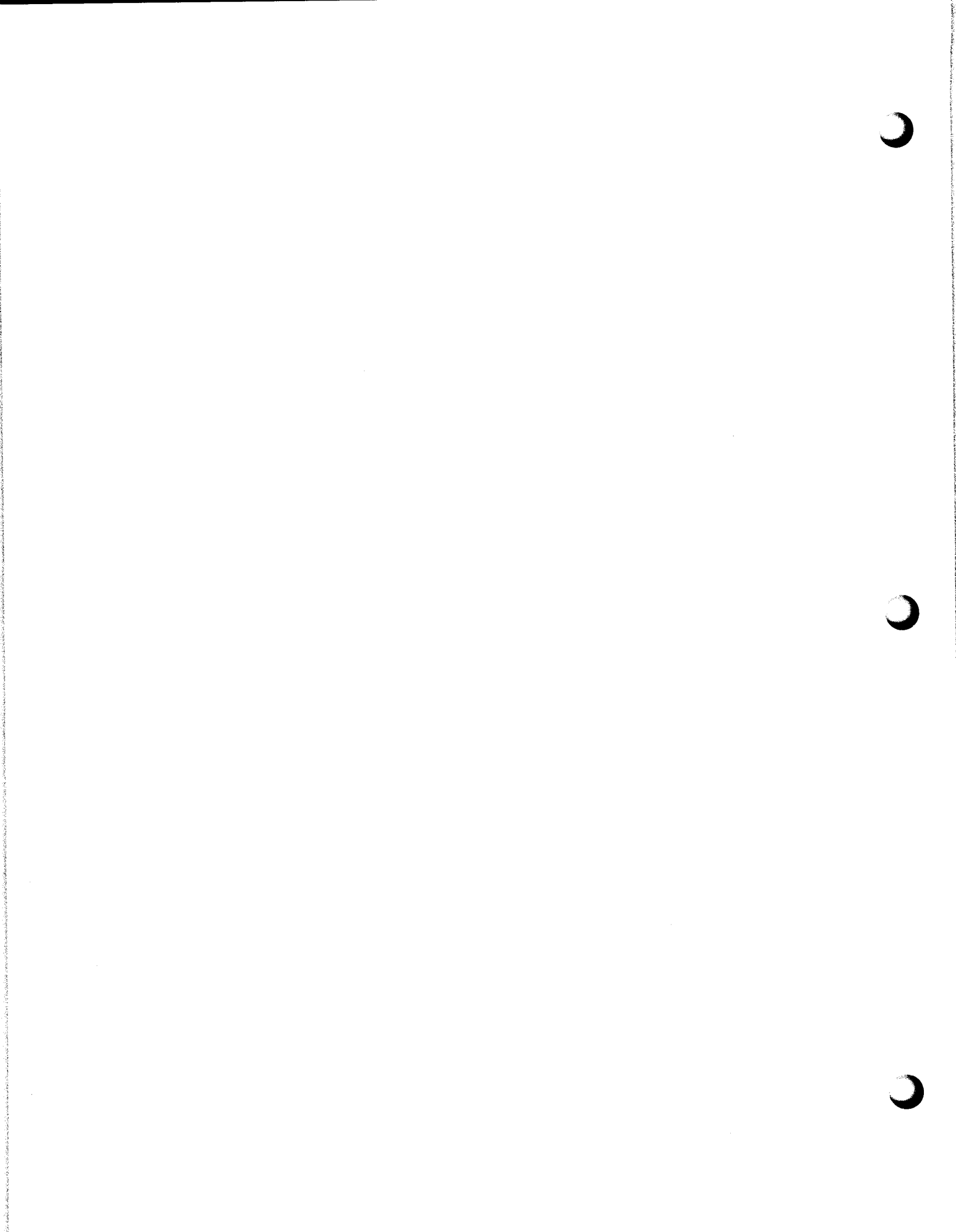

**Revised Pump Station Layout Plan**



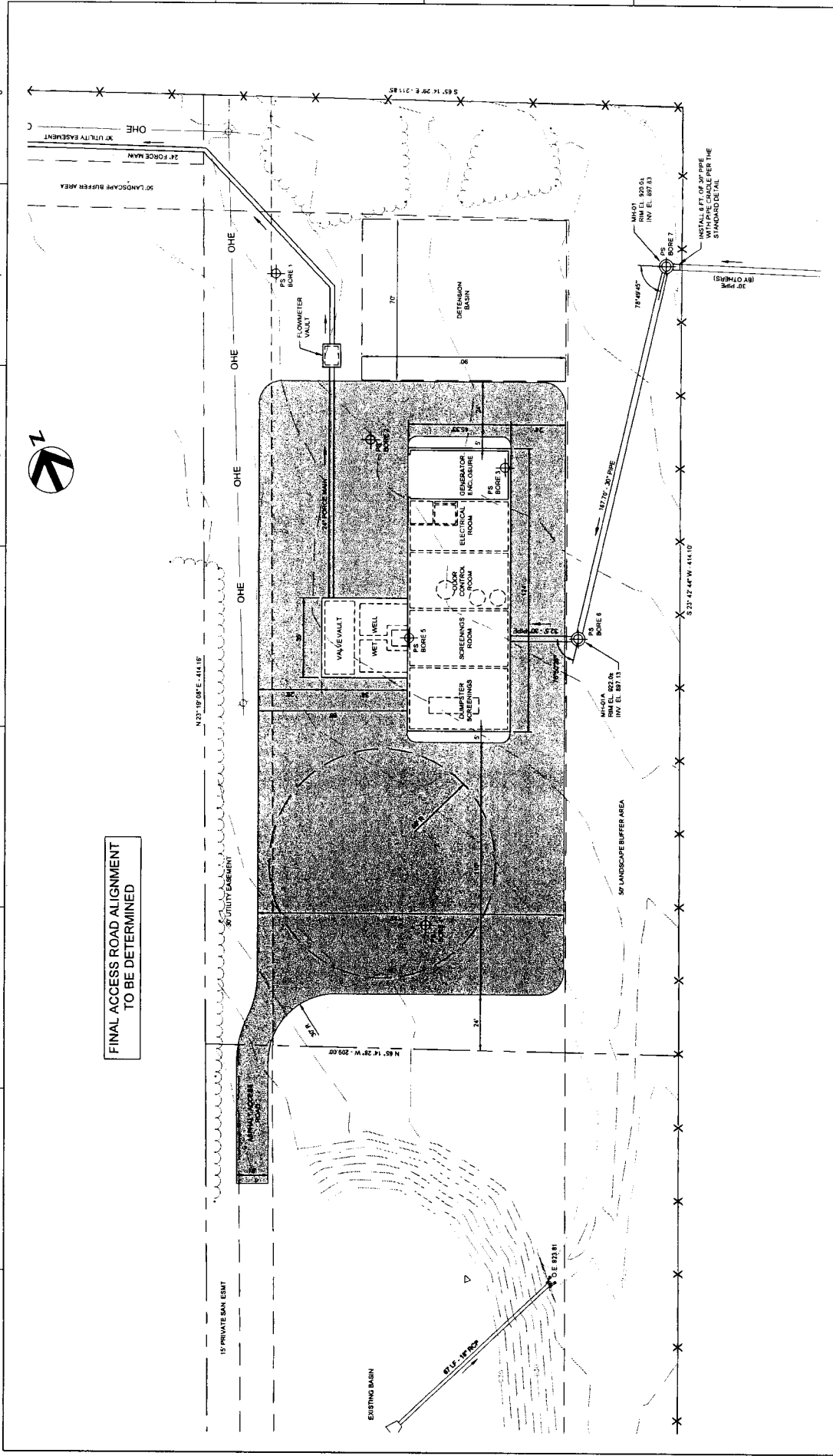

FINAL ACCESS ROAD ALIGNMENT TO BE DETERMINED



**SITE LAYOUT PLAN**  
 FILE NAME: 01C-02  
 SCALE: 1" = 20'  
 SHEET: 01C-02

**EXPANSION AREA 3  
 PUMP STATION AND FORCE MAIN  
 IMPROVEMENTS**

**PRELIMINARY  
 NOT FOR  
 CONSTRUCTION OR  
 RECORDING**

PROJECT MANAGER	P. BENTON-HANSON
DRAWN	
CHECKED	
DATE	
PROJECT NUMBER	1041473

ISSUE	DATE	DESCRIPTION



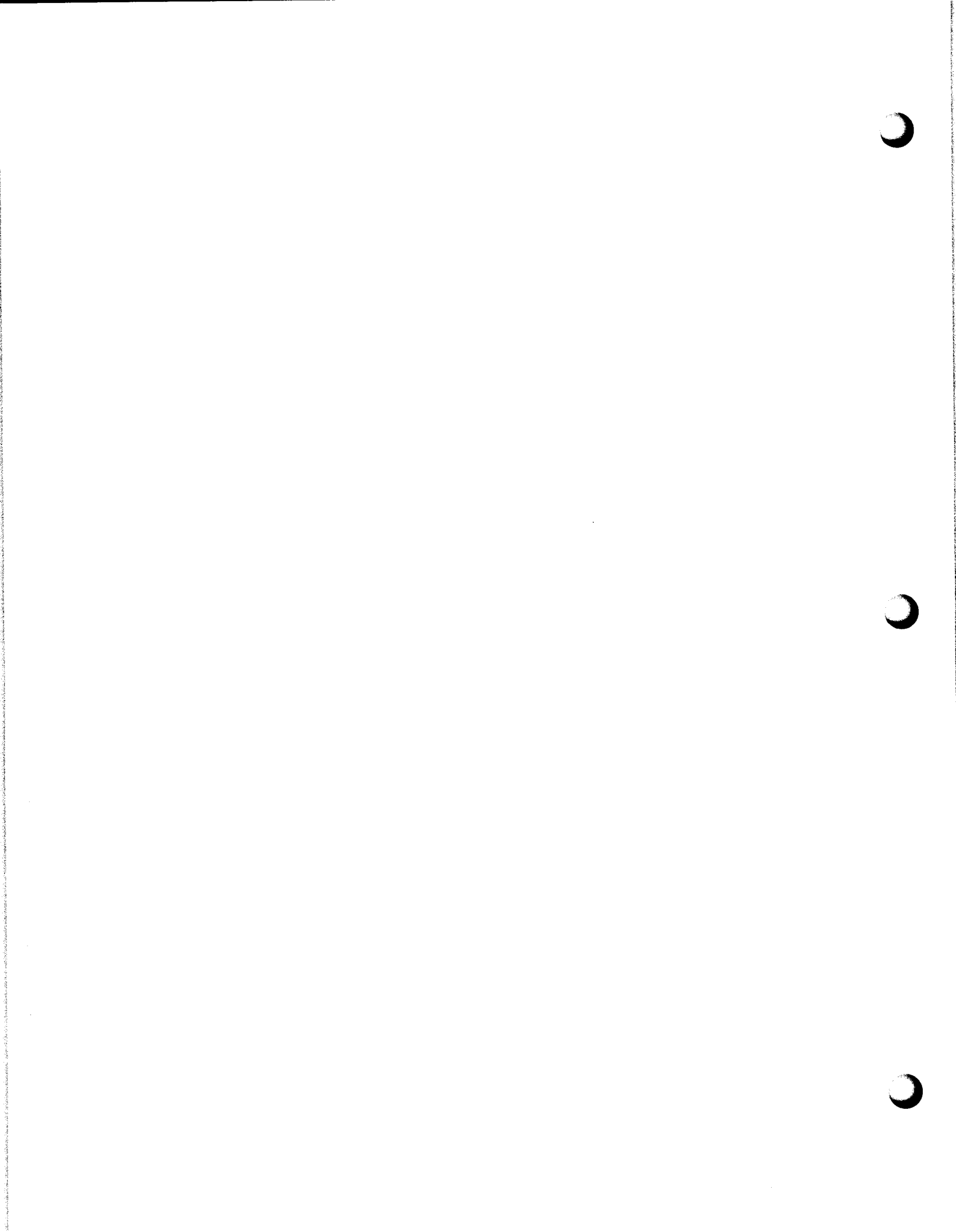

ATTACHMENT B: Rock Line Sounding Summary

---

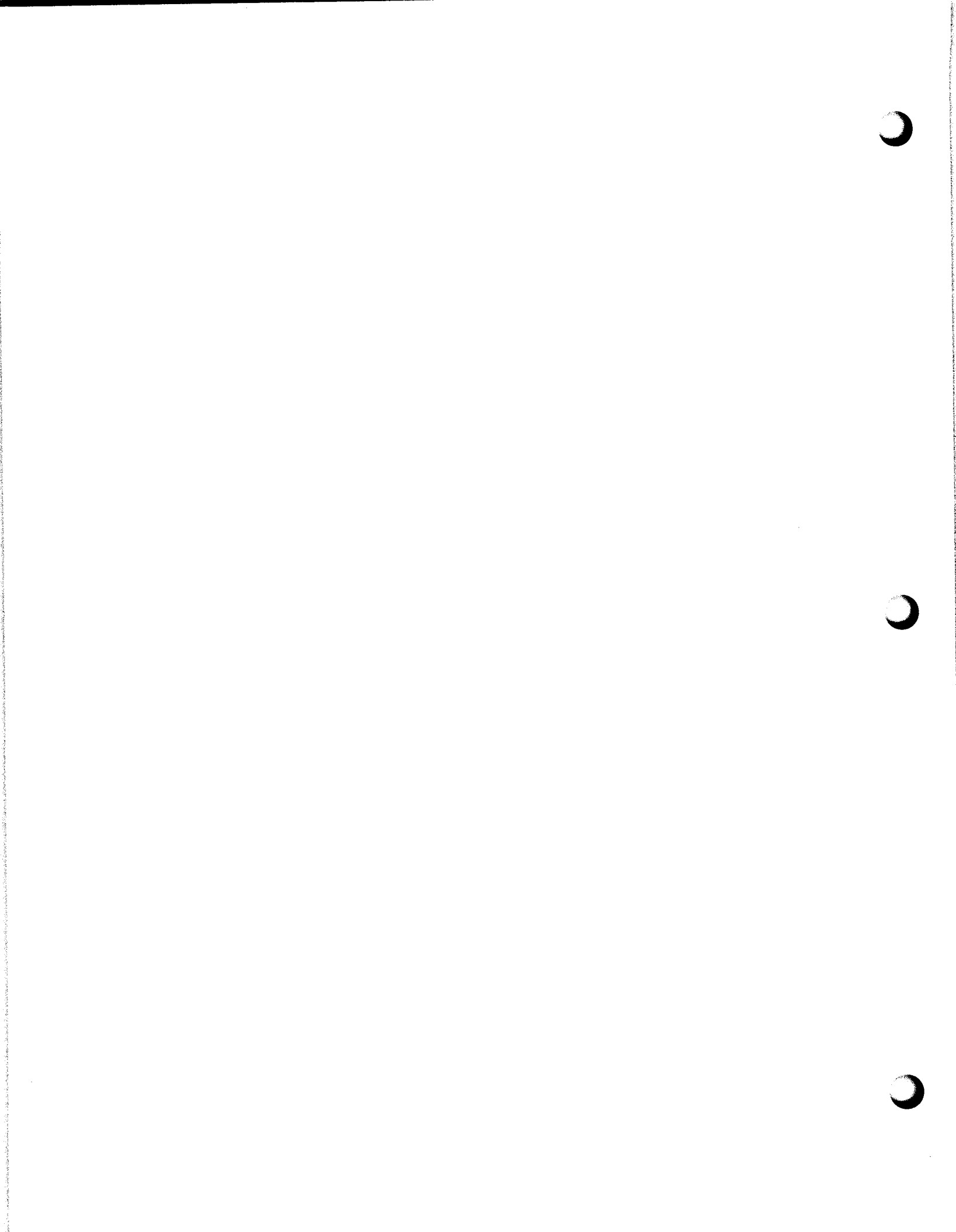





LEXINGTON-FAYETTE URBAN COUNTY GOVERNMENT (LFUCG)  
EA3 FORCE MAIN - ROCK LINE SOUNDINGS

DATUM  
NAD 83 - SPC KENTUCKY NORTH ZONE GRID  
NAVD 88/GEIOD 12B

BORING NO.	NORTHING	EASTING	GROUND ELEVATION (FEET)	BORING TERMINATION DEPTH (FEET)	AUGER REFUSAL DEPTH (FEET)	BOTTOM OF BORING ELEVATION (FEET)
FM-1	220524.112	1574786.739	924.13	5.7	5.7	918.43
FM-2	220545.177	1574741.393	925.02	5.7	5.7	919.32
FM-3	220566.243	1574696.047	925.79	5.9	5.9	919.89
FM-4	220587.308	1574650.701	927.01	6.9	6.9	920.11
FM-5	220608.374	1574605.356	928.03	6.9	6.9	921.13
FM-6	220629.440	1574560.010	928.48	7.3	7.3	921.18
FM-7	220650.505	1574514.664	928.67	7.5	7.5	921.17
FM-8	220671.571	1574469.318	928.75	7.2	7.2	921.55
FM-9	220692.636	1574423.972	928.89	7.3	7.3	921.59
FM-10	220713.702	1574378.627	929.67	6.7	6.7	922.97
FM-11	220734.767	1574333.281	930.75	3.9	3.9	926.85
FM-12	220755.833	1574287.935	932.13	3.4	3.4	928.73
FM-13	220776.899	1574242.589	933.47	2.7	2.7	930.77
FM-14	220797.964	1574197.243	934.91	3.8	3.8	931.11
FM-15	220819.030	1574151.898	936.54	4.4	4.4	932.14
FM-16	220840.095	1574106.552	937.53	5.4	5.4	932.13
FM-17	220861.161	1574061.206	937.63	5.8	5.8	931.83
FM-18	220882.226	1574015.860	936.87	6.3	6.3	930.57
FM-19	220903.292	1573970.514	936.17	6.2	6.2	929.97
FM-20	220924.357	1573925.168	936.06	8.0	No Refusal	928.06
FM-21	220945.423	1573879.823	935.99	5.9	5.9	930.09
FM-22	220966.489	1573834.477	935.17	3.8	3.8	931.37
FM-23	220987.554	1573789.131	934.58	4.4	4.4	930.18
FM-24	221008.620	1573743.785	934.57	4.4	4.4	930.17
FM-25	221029.685	1573698.439	934.46	4.3	4.3	930.16
FM-26	221050.751	1573653.094	933.90	4.3	4.3	929.60
FM-27	221071.816	1573607.748	933.76	8.0	No Refusal	925.76
FM-28	221092.882	1573562.402	933.46	4.7	4.7	928.76
FM-29	221113.948	1573517.056	932.46	8.0	No Refusal	924.46
FM-30	221136.117	1573472.272	932.35	8.0	No Refusal	924.35
FM-31	221161.215	1573429.053	932.80	8.0	No Refusal	924.80
FM-32	221245.583	1573247.721	942.26	5.5	5.5	936.76
FM-33	221205.695	1573227.424	943.24	7.9	7.9	935.34
FM-34	221157.258	1573215.087	943.97	8.0	No Refusal	935.97
FM-35	221110.313	1573197.930	945.18	7.3	7.3	937.88
FM-36	221063.727	1573179.771	946.02	8.0	No Refusal	938.02
FM-37	221017.141	1573161.612	947.38	3.8	3.8	943.58
FM-38	220970.555	1573143.453	949.48	6.1	6.1	943.38
FM-39	220923.969	1573125.295	951.48	4.1	4.1	947.38
FM-40	220877.383	1573107.136	953.07	6.1	6.1	946.97
FM-41	220830.797	1573088.977	954.35	4.8	4.8	949.55
FM-42	220765.499	1573063.839	955.57	3.0	3.0	952.57
FM-43	220737.314	1573053.504	955.80	6.0	6.0	949.80
FM-44	220690.080	1573037.105	955.38	3.8	3.8	951.58



BORING NO.	NORTHING	EASTING	GROUND ELEVATION (FEET)	BORING TERMINATION DEPTH (FEET)	AUGER REFUSAL DEPTH (FEET)	BOTTOM OF BORING ELEVATION (FEET)
FM-45	220642.845	1573020.707	954.93	4.7	4.7	950.23
FM-46	220595.611	1573004.308	954.86	4.8	4.8	950.06
FM-47	220548.393	1572987.864	954.85	4.3	4.3	950.55
FM-48	220501.684	1572970.025	955.17	3.1	3.1	952.07
FM-49	220454.975	1572952.185	955.33	4.0	4.0	951.33
FM-50	220408.265	1572934.345	954.40	5.5	5.5	948.90
FM-51	220361.324	1572917.174	953.67	5.1	5.1	948.57
FM-52	220313.625	1572902.182	952.36	4.1	4.1	948.26
FM-53	220265.925	1572887.189	950.19	5.5	5.5	944.69
FM-54	220218.226	1572872.197	948.55	8.0	8.0	940.55
FM-55	220170.526	1572857.205	946.59	7.9	7.9	938.69
FM-56	220122.870	1572842.076	944.46	7.4	7.4	937.06
FM-57	220075.224	1572826.915	942.59	8.0	No Refusal	934.59
FM-58	220027.508	1572811.977	941.14	7.1	7.1	934.04
FM-59	219979.715	1572797.287	939.78	8.0	No Refusal	931.78
FM-60	219931.911	1572782.632	938.45	8.0	No Refusal	930.45
FM-61	219883.829	1572768.916	937.57	8.0	No Refusal	929.57
FM-62	219835.747	1572755.200	936.24	8.0	No Refusal	928.24
FM-63	219787.661	1572741.499	934.01	8.0	No Refusal	926.01
FM-64	219740.025	1572726.329	930.99	6.2	6.2	924.79
FM-65	219693.295	1572708.560	928.65	5.1	5.1	923.55
FM-66	219656.548	1572692.823	926.86	6.8	6.8	920.06
FM-67	219591.702	1572666.515	923.10	5.3	5.3	917.80
FM-68	219553.054	1572656.490	921.42	6.2	6.2	915.22
FM-69	219503.711	1572648.484	919.66	5.1	5.1	914.56
FM-70	219454.245	1572641.199	918.81	7.7	7.7	911.11
FM-71	219404.778	1572633.915	918.41	4.5	4.5	913.91
FM-72	219355.312	1572626.630	916.90	2.0	2.0	914.90
FM-73	219305.845	1572619.345	916.38	4.1	4.1	912.28
FM-74	219256.170	1572614.038	916.63	8.0	8.0	908.63
FM-75	219206.273	1572610.831	916.52	8.0	No Refusal	908.52
FM-76	219156.376	1572607.625	916.37	4.7	4.7	911.67
FM-77	219106.479	1572604.418	917.51	8.0	8.0	909.51
FM-78	219056.582	1572601.211	915.05	6.1	6.1	908.95
FM-79	219022.785	1572576.320	918.69	3.0	3.0	915.69
FM-80	219021.961	1572526.368	917.34	3.7	3.7	913.64
FM-81	219018.525	1572476.486	917.40	3.5	3.5	913.90
FM-82	219015.088	1572426.605	917.40	4.1	4.1	913.30
FM-83	219011.652	1572376.723	917.02	3.7	3.7	913.32
FM-84	219008.216	1572326.841	915.40	2.5	2.5	912.90
FM-85	218997.060	1572279.117	915.36	3.7	3.7	911.66
FM-86	218994.733	1572229.171	914.83	4.9	4.9	909.93
FM-87	219005.371	1572181.640	913.71	6.5	6.5	907.21
FM-88	219027.639	1572136.874	912.16	5.1	5.1	907.06
FM-89	219050.044	1572092.175	910.63	8.0	No Refusal	902.63
FM-90	219072.522	1572047.513	909.91	4.2	4.2	905.71
FM-91	219095.001	1572002.850	909.43	8.0	8.0	901.43
FM-92	219117.479	1571958.188	909.28	8.0	No Refusal	901.28
FM-93	219139.924	1571913.509	909.15	8.0	No Refusal	901.15
FM-94	219162.324	1571868.807	909.44	5.0	5.0	904.44
FM-95	219184.556	1571824.025	909.77	3.8	3.8	905.97



BORING NO.	NORTHING	EASTING	GROUND ELEVATION (FEET)	BORING TERMINATION DEPTH (FEET)	AUGER REFUSAL DEPTH (FEET)	BOTTOM OF BORING ELEVATION (FEET)
FM-96	219205.528	1571778.635	910.59	2.1	2.1	908.49
FM-97	219226.500	1571733.246	912.88	2.9	2.9	909.98
FM-98	219247.372	1571687.812	914.63	4.7	4.7	909.93
FM-99	219266.082	1571645.850	916.39	4.3	4.3	912.09
FM-100	219017.351	1571478.121	905.81	8.0	No Refusal	897.81
FM-101	218975.896	1571450.166	904.35	7.8	7.8	896.55
FM-102	218934.441	1571422.212	903.89	8.0	No Refusal	895.89
FM-103	218918.747	1571380.711	903.27	6.9	6.9	896.37



LEXINGTON-FAYETTE URBAN COUNTY GOVERNMENT (LFUCG)  
EA3 PUMP STATION - ROCK LINE SOUNDINGS

DATUM

NAD 83 - SPC KENTUCKY NORTH ZONE GRID  
NAVD 88/GEOID 12B

BORING NO.	NORTHING	EASTING	GROUND ELEVATION (FEET)	BORING TERMINATION DEPTH (FEET)	BOTTOM OF BORING ELEVATION (FEET)
PS-6	220262.455	1574853.822	922.66	6.1	916.56
PS-7	220396.640	1574954.420	920.48	5.3	915.18

**ATTACHMENT C: Boring Logs and Laboratory Testing**

---





HDR, Inc.  
2517 Sir Barton Way  
Lexington, KY 40509

# BORING NUMBER PS-1

PAGE 1 OF 1

CLIENT Lexington Fayette County Urban County Government (LFUCG) PROJECT NAME Expansion Area 3 (EA3) Pump Station  
 PROJECT NUMBER 10041433 PROJECT LOCATION Lexington, KY  
 DATE STARTED 9/20/16 COMPLETED 9/20/16 GROUND ELEVATION 923.78 ft HOLE SIZE inches  
 DRILLING CONTRACTOR HDR Engineering, Inc. GROUND WATER LEVELS:  
 DRILLING METHOD 3.25" Auger w/ SPT AT TIME OF DRILLING --- Dry  
 LOGGED BY Freddie CHECKED BY \_\_\_\_\_ AT END OF DRILLING ---  
 NOTES \_\_\_\_\_ AFTER DRILLING ---

DEPTH (ft)	GRAPHIC LOG	MATERIAL DESCRIPTION	SAMPLE TYPE NUMBER	RECOVERY % (RQD)	BLOW COUNTS (N VALUE)	POCKET PEN. (tsf)	DRY UNIT WT. (pcf)	MOISTURE CONTENT (%)	ATTERBERG LIMITS			FINES CONTENT (%)
									LIQUID LIMIT	PLASTIC LIMIT	PLASTICITY INDEX	
0		Topsoil										
		LEAN CLAY, (CL) brown, moist, stiff to hard										
			SS 1	73	4-5-6 (11)							
5			SS 2	83	4-5-50/1"			22	49	5	44	

Refusal at 6.1 feet.  
Bottom of borehole at 6.1 feet.

GEOTECH BH COLUMNS - GINT STD US LAB.GDT - 10/19/16 11:52 - G:\PROJECTS\10041433 - LFUCG LOWER CAME RUN EXPANSION\GINT\LFUCG EA3 PS & FM.GPJ

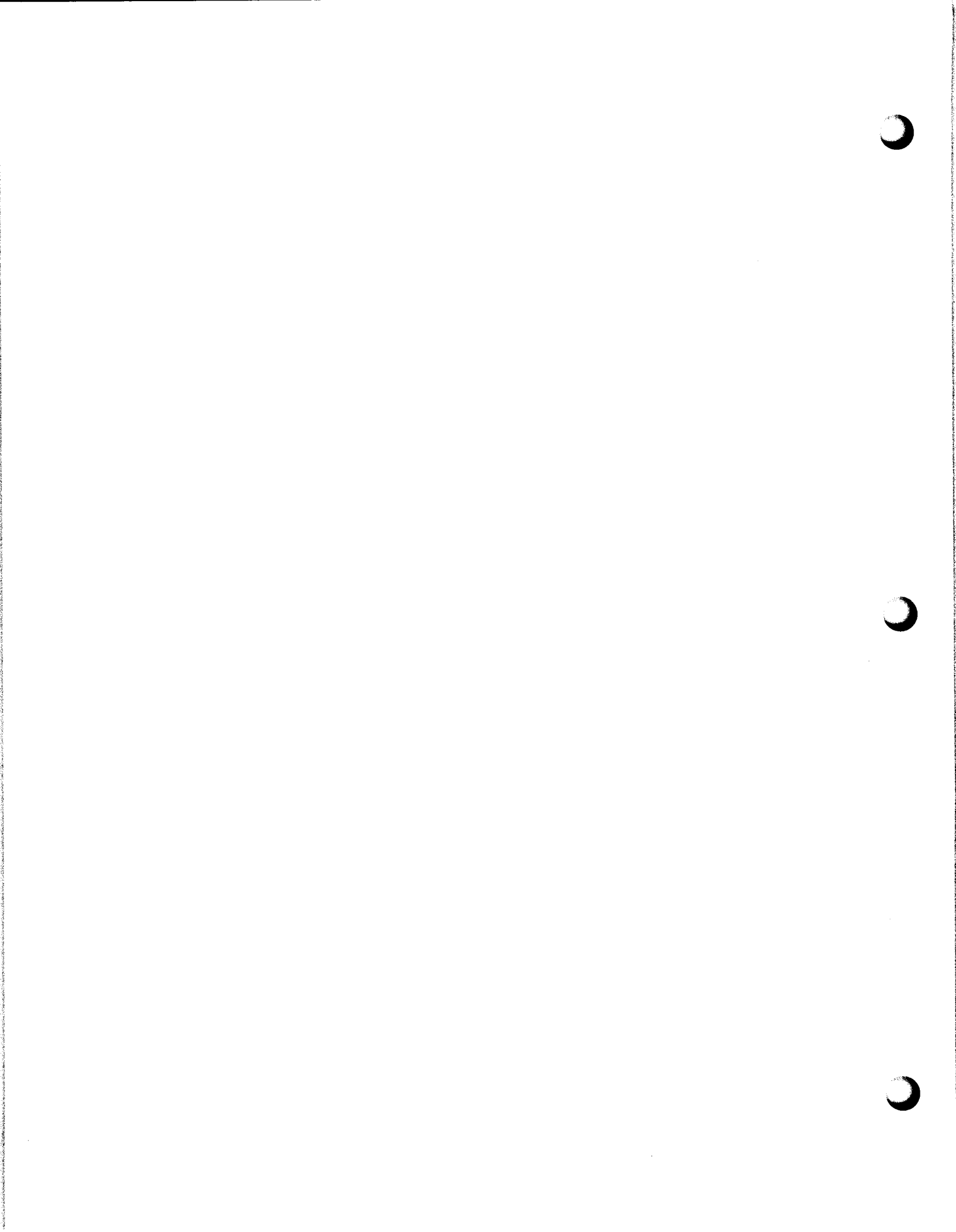





HDR, Inc.  
2517 Sir Barton Way  
Lexington, KY 40509

# BORING NUMBER PS-2

PAGE 1 OF 2

CLIENT Lexington Fayette County Urban County Government (LFUCG)

PROJECT NAME Expansion Area 3 (EA3) Pump Station

PROJECT NUMBER 10041433

PROJECT LOCATION Lexington, KY

DATE STARTED 9/20/16 COMPLETED 9/21/16

GROUND ELEVATION 923.19 ft HOLE SIZE inches

DRILLING CONTRACTOR HDR Engineering, Inc.

GROUND WATER LEVELS:

DRILLING METHOD 3.25" Auger w/ SPT and Rock Cores

AT TIME OF DRILLING --- Dry

LOGGED BY Freddie CHECKED BY \_\_\_\_\_

AT END OF DRILLING ---

NOTES \_\_\_\_\_

AFTER DRILLING ---

DEPTH (ft)	GRAPHIC LOG	MATERIAL DESCRIPTION	SAMPLE TYPE NUMBER	RECOVERY % (RQD)	BLOW COUNTS (N VALUE)	POCKET PEN. (tsf)	DRY UNIT WT. (pcf)	MOISTURE CONTENT (%)	ATTERBERG LIMITS			FINES CONTENT (%)
									LIQUID LIMIT	PLASTIC LIMIT	PLASTICITY INDEX	
0		Topsoil SILT, (ML) brown, moist, stiff to hard										
5			SS 1	47	5-6-6 (12)							
5		LIMESTONE, medium to very coarse grained, sub-rounded to sub-angular, shale lenses	SS 2	0	50/1"							
			RC 1	100 (67)								
10			RC 2	100 (100)								
15			RC 3	100 (100)								
20			RC 4	98 (90)								
25												

GEO TECH BH COLUMNS - GINT STD US LAB GDT - 10/19/16 11:52 - G:\PROJECTS\10041433 - LFUCG LOWER CANE RUN EXPANSION\GINT\LFUCG EA3 PS & FM.GPJ

(Continued Next Page)



HDR, Inc.  
2517 Sir Barton Way  
Lexington, KY 40509

**BORING NUMBER PS-2**

PAGE 2 OF 2

CLIENT Lexington Fayette County Urban County Government (LFUCG)

PROJECT NAME Expansion Area 3 (EA3) Pump Station

PROJECT NUMBER 10041433

PROJECT LOCATION Lexington, KY

GEO TECH BH COLUMNS - GINT STD US LAB.GDT - 10/19/16 11:52 - G:\PROJECTS\10041433 - LFUCG LOWER CANE RUN EXPANSION\GINT\LFUCG EA3 PS & FM.GPJ

DEPTH (ft)	GRAPHIC LOG	MATERIAL DESCRIPTION	SAMPLE TYPE NUMBER	RECOVERY % (RQD)	BLOW COUNTS (N VALUE)	POCKET PEN. (tsf)	DRY UNIT WT. (pcf)	MOISTURE CONTENT (%)	ATTERBERG LIMITS			FINES CONTENT (%)
									LIQUID LIMIT	PLASTIC LIMIT	PLASTICITY INDEX	
25		LIMESTONE, medium to very coarse grained, sub-rounded to sub-angular, shale lenses <i>(continued)</i>	RC 5	100 (56)								
30			RC 6	98 (84)								
35			RC 7	100 (96)								
40			RC 8	100 (96)		452	166					
45			RC 9	86 (76)								
Refusal at 5.0 feet. Bottom of borehole at 47.5 feet.												



HDR, Inc.  
2517 Sir Barton Way  
Lexington, KY 40509

# BORING NUMBER PS-3

PAGE 1 OF 1

CLIENT Lexington Fayette County Urban County Government (LFUCG) PROJECT NAME Expansion Area 3 (EA3) Pump Station  
 PROJECT NUMBER 10041433 PROJECT LOCATION Lexington, KY  
 DATE STARTED 9/20/16 COMPLETED 9/20/16 GROUND ELEVATION 921.76 ft HOLE SIZE inches  
 DRILLING CONTRACTOR HDR Engineering, Inc. GROUND WATER LEVELS:  
 DRILLING METHOD 3.25" Auger w/ SPT AT TIME OF DRILLING --- Dry  
 LOGGED BY Freddie CHECKED BY \_\_\_\_\_ AT END OF DRILLING ---  
 NOTES \_\_\_\_\_ AFTER DRILLING ---

DEPTH (ft)	GRAPHIC LOG	MATERIAL DESCRIPTION	SAMPLE TYPE NUMBER	RECOVERY % (RQD)	BLOW COUNTS (N VALUE)	POCKET PEN. (tsf)	DRY UNIT WT. (pcf)	MOISTURE CONTENT (%)	ATTERBERG LIMITS			FINES CONTENT (%)
									LIQUID LIMIT	PLASTIC LIMIT	PLASTICITY INDEX	
0		Topsoil										
		SILT, (ML) brown, moist, stiff										
			SS 1	47	4-5-5 (10)			31	41	41	NP	100

Refusal at 4.8 feet.  
Bottom of borehole at 4.8 feet.

GEOTECH BH COLUMNS - GINT STD US LAB.GDT - 10/19/16 11:52 - G:\PROJECTS\10041433 - LFUCG LOWER CAME RUN EXPANSION\GINT\LFUCG EA3 PS & FM.GPJ





HDR, Inc.  
2517 Sir Barton Way  
Lexington, KY 40509

**BORING NUMBER PS-4**

PAGE 1 OF 1

CLIENT Lexington Fayette County Urban County Government (LFUCG)

PROJECT NAME Expansion Area 3 (EA3) Pump Station

PROJECT NUMBER 10041433

PROJECT LOCATION Lexington, KY

DATE STARTED 9/20/16 COMPLETED 9/20/16

GROUND ELEVATION 926.21 ft HOLE SIZE inches

DRILLING CONTRACTOR HDR Engineering, Inc.

GROUND WATER LEVELS:

DRILLING METHOD 3.25" Auger w/ SPT

AT TIME OF DRILLING --- Dry

LOGGED BY Freddie CHECKED BY \_\_\_\_\_

AT END OF DRILLING ---

NOTES \_\_\_\_\_

AFTER DRILLING ---

GEOTECH BH COLUMNS - GINT STD US LAB.GDT - 10/19/16 11:52 - G:\PROJECTS\10041433 - LFUCG LOWER CANE RUN EXPANSION\GINT\LFUCG EA3 PS & FM.GPJ

DEPTH (ft)	GRAPHIC LOG	MATERIAL DESCRIPTION	SAMPLE TYPE NUMBER	RECOVERY % (RQD)	BLOW COUNTS (N VALUE)	POCKET PEN. (tsf)	DRY UNIT WT. (pcf)	MOISTURE CONTENT (%)	ATTERBERG LIMITS			FINES CONTENT (%)
									LIQUID LIMIT	PLASTIC LIMIT	PLASTICITY INDEX	
0		Topsoil										
		LEAN CLAY, (CL) light brown to dark brown, moist, stiff to very stiff										
			SS 1	60	8-10-10 (20)							
5			SS 2	47	6-7-9 (16)							
		Refusal at 7.6 feet. Bottom of borehole at 7.6 feet.	SS 3	100	50/1"							

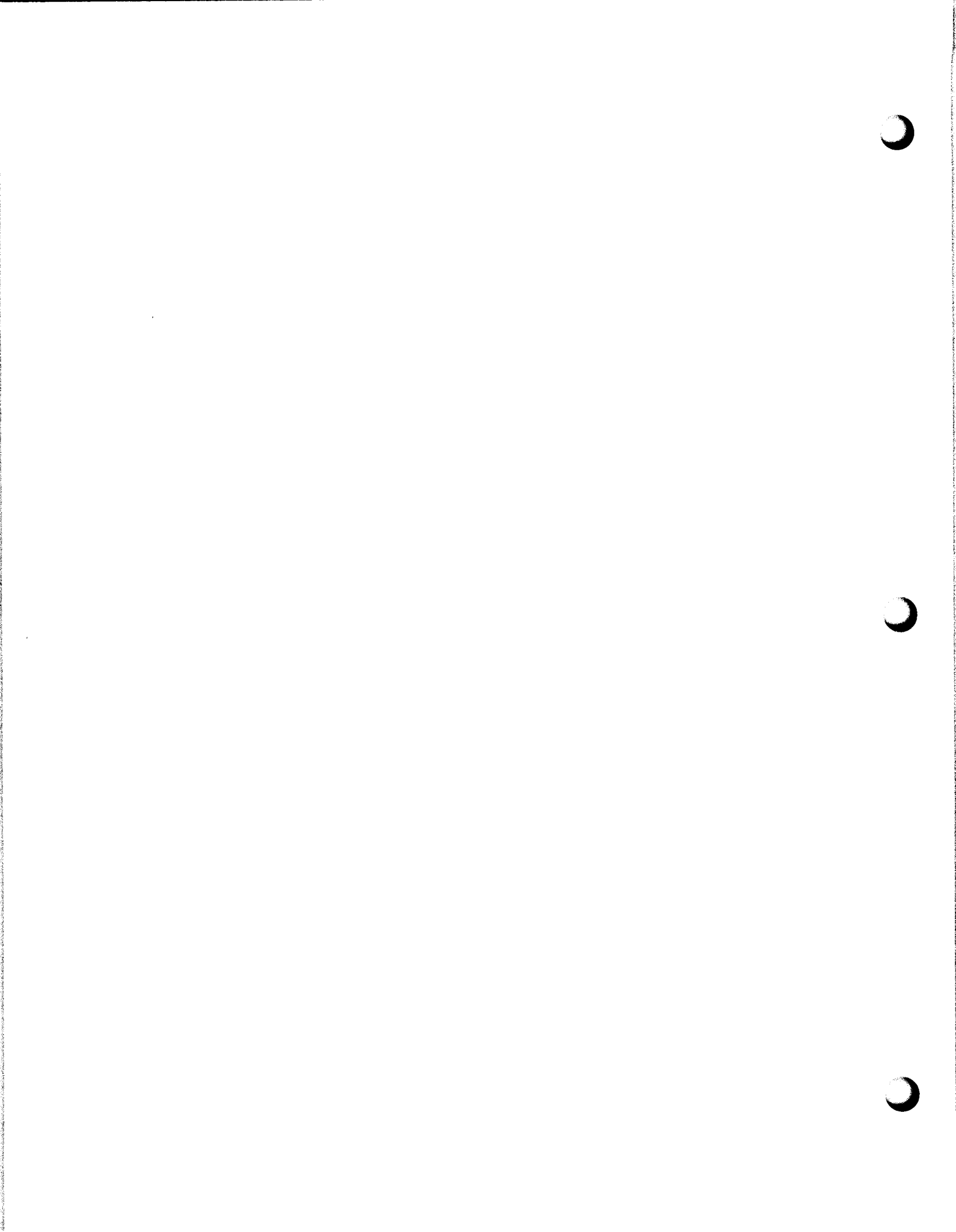



HDR, Inc.  
2517 Sir Barton Way  
Lexington, KY 40509

# BORING NUMBER PS-5

PAGE 1 OF 3

CLIENT Lexington Fayette County Urban County Government (LFUCG) PROJECT NAME Expansion Area 3 (EA3) Pump Station  
 PROJECT NUMBER 10041433 PROJECT LOCATION Lexington, KY  
 DATE STARTED 1/30/17 COMPLETED 1/30/17 GROUND ELEVATION 923.64 ft HOLE SIZE inches  
 DRILLING CONTRACTOR Horn and Associates, Inc. GROUND WATER LEVELS:  
 DRILLING METHOD 4.25" HSA w/ Rock Core AT TIME OF DRILLING ---  
 LOGGED BY B. Robbins CHECKED BY --- AT END OF DRILLING ---  
 NOTES Weather: Clear AFTER DRILLING ---

DEPTH (ft)	GRAPHIC LOG	MATERIAL DESCRIPTION	SAMPLE TYPE NUMBER	RECOVERY % (RQD)	BLOW COUNTS (N VALUE)	POCKET PEN. (tsf)	DRY UNIT WT. (pcf)	MOISTURE CONTENT (%)	ATTERBERG LIMITS			FINES CONTENT (%)
									LIQUID LIMIT	PLASTIC LIMIT	PLASTICITY INDEX	
0		LEAN CLAY, (CL) brown, moist, silty w/ organics										
5												
10		LIMESTONE, slightly weathered to unweathered, gray and light gray, moderately strong to strong, very fine to medium grained, slightly to moderately fractured, contains shale streaks, stringers and partings	RC 1	99 (90)								
15												
20			RC 2	100 (94)								
25												

GEOTECH BH COLUMNS - GINT STD US LAB.GDT - 2/10/17 09:43 - G:\PROJECTS\COMPLETED\2016\10041433 - LFUCG LOWER CANE RUN EXPANSION\GINT\LFUCG EA3 PS & FM.GPJ

(Continued Next Page)



HDR, Inc.  
2517 Sir Barton Way  
Lexington, KY 40509

**BORING NUMBER PS-5**

PAGE 2 OF 3

CLIENT Lexington Fayette County Urban County Government (LFUCG) PROJECT NAME Expansion Area 3 (EA3) Pump Station

PROJECT NUMBER 10041433

PROJECT LOCATION Lexington, KY

DEPTH (ft)	GRAPHIC LOG	MATERIAL DESCRIPTION	SAMPLE TYPE NUMBER	RECOVERY % (RQD)	BLOW COUNTS (N VALUE)	POCKET PEN. (tsf)	DRY UNIT WT. (pcf)	MOISTURE CONTENT (%)	ATTERBERG LIMITS			FINES CONTENT (%)
									LIQUID LIMIT	PLASTIC LIMIT	PLASTICITY INDEX	
25		LIMESTONE, slightly weathered to unweathered, gray and light gray, moderately strong to strong, very fine to medium grained, slightly to moderately fractured, contains shale streaks, stringers and partings <i>(continued)</i> 25.7 feet - 27.0 feet Highly fractured w/ high shale concentration  28.0 feet - 28.7 feet Highly fractured w/ high shale concentration	RC 3	100 (66)								
30												
35												
40		37.8 feet - 38.1 feet Vertical Joint (90 deg.)	RC 4	99 (93)								
45												
50			RC 5	100 (100)								

GEO TECH BH COLUMNS - GINT STD US LAB.GDT - 2/10/17 09:43 - G:\PROJECTS\COMPLETED\2016\10041433 - LFUCG LOWER CANE RUN EXPANSION\GINT\LFUCG EA3 PS & FM.GPJ

(Continued Next Page)





HDR, Inc.  
2517 Sir Barton Way  
Lexington, KY 40509

**BORING NUMBER PS-5**

PAGE 3 OF 3

CLIENT Lexington Fayette County Urban County Government (LFUCG) PROJECT NAME Expansion Area 3 (EA3) Pump Station

PROJECT NUMBER 10041433 PROJECT LOCATION Lexington, KY

DEPTH (ft)	GRAPHIC LOG	MATERIAL DESCRIPTION	SAMPLE TYPE NUMBER	RECOVERY % (RQD)	BLOW COUNTS (N VALUE)	POCKET PEN. (tsf)	DRY UNIT WT. (pcf)	MOISTURE CONTENT (%)	ATTERBERG LIMITS			FINES CONTENT (%)
									LIQUID LIMIT	PLASTIC LIMIT	PLASTICITY INDEX	
55		LIMESTONE, slightly weathered to unweathered, gray and light gray, moderately strong to strong, very fine to medium grained, slightly to moderately fractured, contains shale streaks, stringers and partings (continued)										

Refusal at 6.0 feet.  
Bottom of borehole at 56.0 feet.

GEOTECH BH COLUMNS - GINT STD US LAB.GDT - 2/10/17 09:43 - G:\PROJECTS\COMPLETED\2016\10041433 - LFUCG LOWER CANE RUN EXPANSION\GINT\LFUCG EA3 PS & FM.GPJ

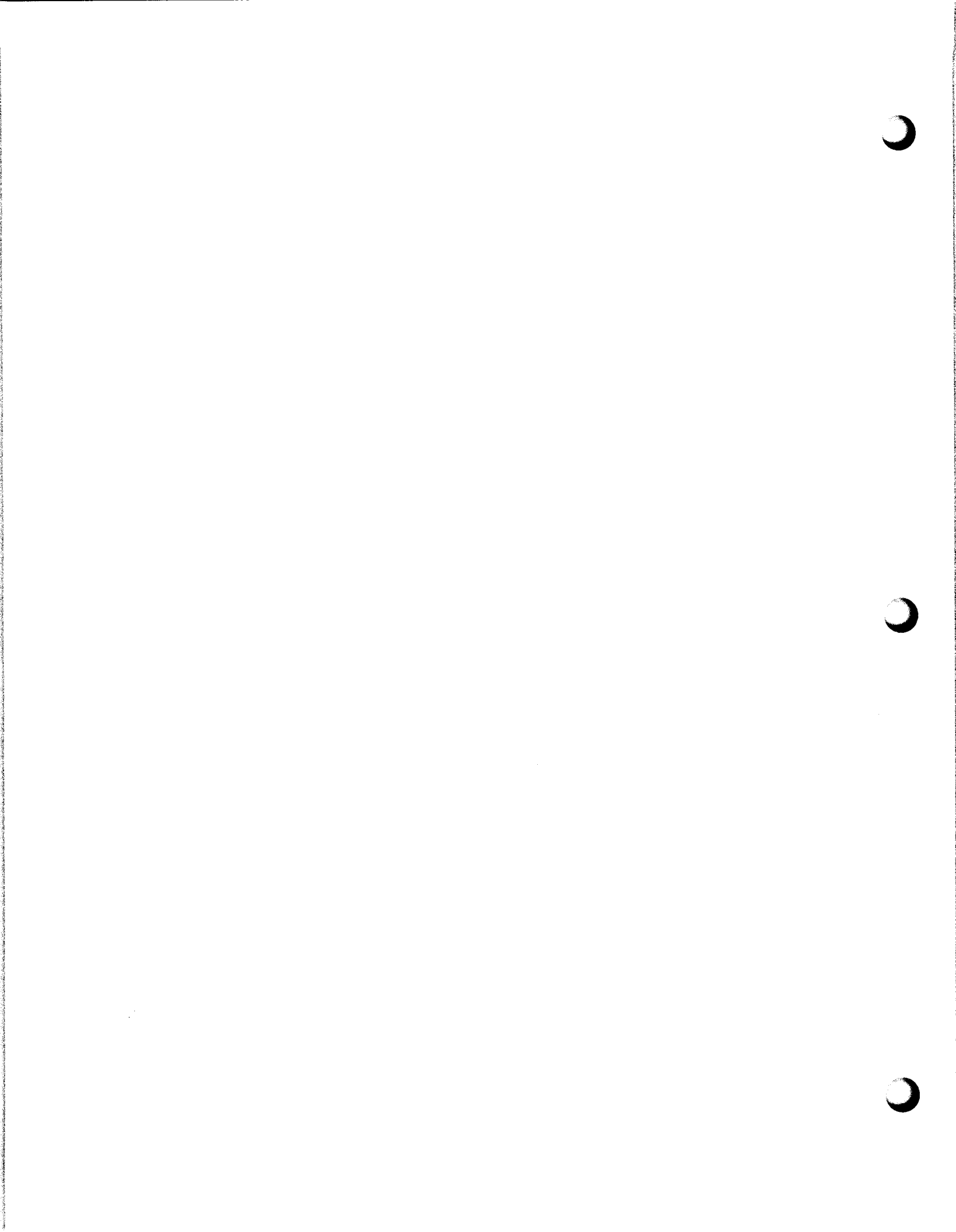



Project Name : LFUCG Area 3 Pump Station  
 Location : Lexington County, Kentucky  
 Job Number : 10041433  
 Project Job No. : 10041433

**Moisture Data**

(AASHTO T255-T265 / ASTM C566-D2216)

Natural  
 Moisture  
 Content  
 (%)

Soil No.	Boring No.	Station & Offset	Sample No.	Depth		Description of Soil	pH	Natural Moisture Content (%)
1	PS-1		SS-1	2.5	4.0	Brown Lean Clay		
1			SS-2	4.9	6.0	Brown Lean Clay		22.0
2	PS-2		SS-1	2.5	4.0	Brown Silt		
			SS-2	4.9	5.0	No Recovery		
2	PS-3		SS-1	2.5	4.0	Brown Silt		30.9
1	PS-4		SS-1	2.5	4.0	Brown Lean Clay		
1			SS-2	5.0	6.5	Brown Lean Clay		
			SS-3	7.5	7.6	No Recovery		

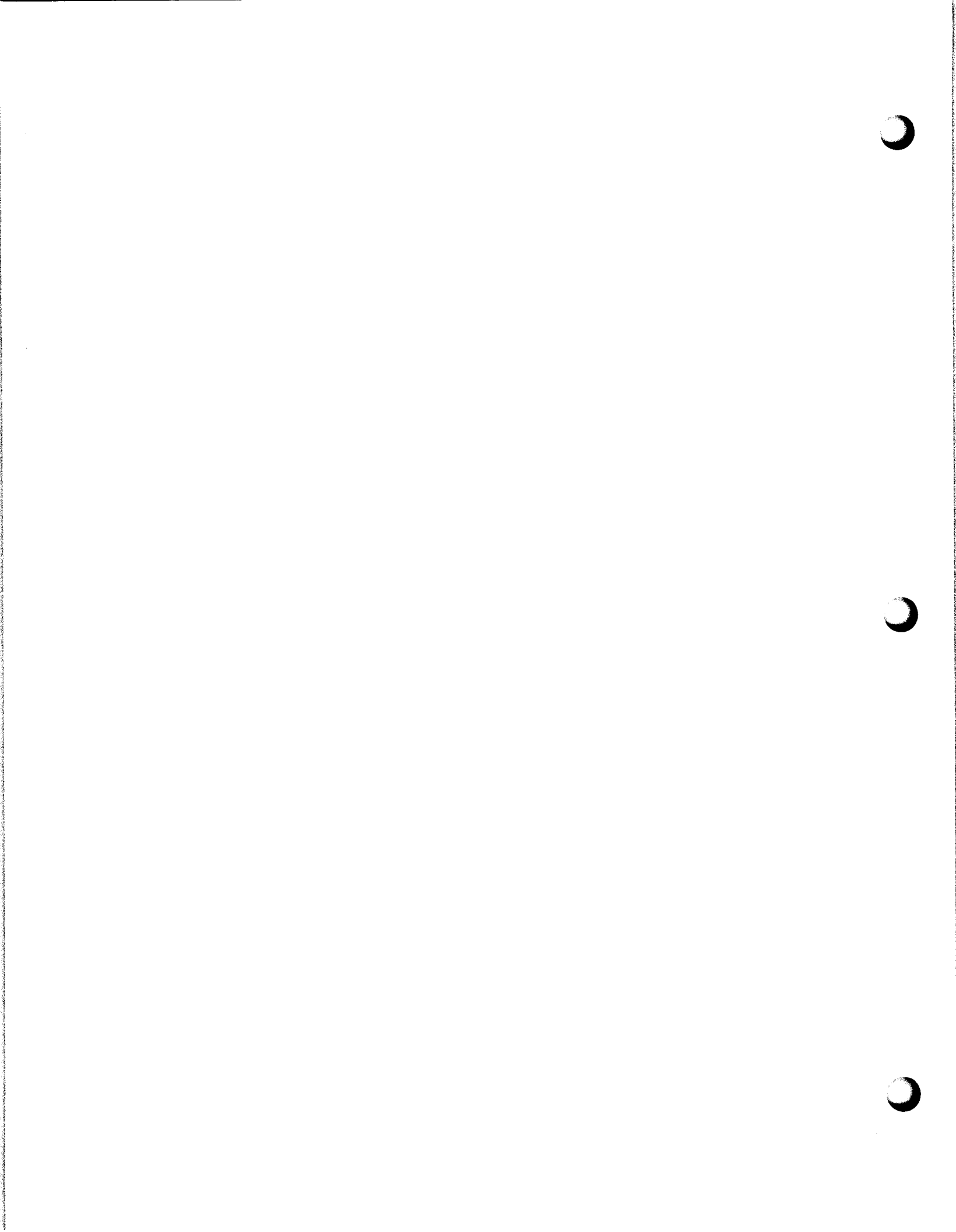



# SOIL CLASSIFICATION

Project Name : LFUCG Area 3 Pump Station  
 Project No. : 10041433  
 Project County : Lexington  
 Project State : Kentucky  
 Laboratory No. : 10041433  
 Submitted By : HDR  
 Soil Type : Brown Lean Clay

Sample No. : SS-2  
 Sample Loc. : Boring No. PS-1  
 Sample Depth : 4.9' to 6.0'  
 Date Tested : 10/04/16  
 Date Reported : 10/07/16

### AASHTO T27 :

% Passing			
4	in.	101.6	mm
3.5	in.	88.9	mm
3	in.	76.2	mm
2.5	in.	63.5	mm
2	in.	50.8	mm
1 3/4	in.	45	mm
1 1/2	in.	38.1	mm
1 1/4	in.	31.5	mm
1	in.	25	mm
3/4	in.	19	mm
1/2	in.	12.5	mm
3/8	in.	9.5	mm
1/4		6.3	mm
No.4		4.75	mm 100.0
No.6		3.35	mm
No.10		2	mm 100.0

% Passing			
No.16		1.18	mm
No.30		0.6	mm
No.40		0.425	mm 100.0
No.50		0.3	mm
No.60		0.25	mm
No.80		0.18	mm
No.100		0.15	mm
No.200		0.075	mm 100.0
No.270		0.053	mm
Hyd. Rd. # 1			mm
Hyd. Rd. # 2			mm
Hyd. Rd. # 3			mm
Hyd. Rd. # 4			mm
Hyd. Rd. # 5			mm
Hyd. Rd. # 6			mm
Hyd. Rd. # 7			mm

AASHTO T88

CBR : NA  
 Dry Dens. : NA  
 Opt. Moist. : NA

Natural Moisture ( % ) (AASHTO T265) : 22.0  
 Liquid Limit (AASHTO T89) : 49  
 Plastic Limit (AASHTO T90) : 5

### AASHTO Composition of Total Sample: M145

Gravel ( 3in. + No.10 ) : 0.0  
 Coarse Sand ( -No.10 + No.40 ) : 0.0  
 Fine Sand ( -No.40 + No.200 ) : 0.0  
 Silt + Clay ( -No.200 ) : 100.0

Plasticity Index : 44  
 Liquidity Index : 0.39  
 Activity : NA

Sp. Gr. (AASHTO T100) : NA  
 AASHTO Classification: M145 : A-7-6 (45)  
 ASTM Classification: D2487 : CL

### ASTM Composition of Total Sample: D2487

Coarse Gravel ( 3in. + 3/4in. ) : 0.0  
 Fine Gravel ( -3/4in. + No.4 ) : 0.0  
 Coarse Sand ( -No.4 + No.10 ) : 0.0  
 Medium Sand ( -No.10 + No.40 ) : 0.0  
 Fine Sand ( -No.40 + No.200 ) : 0.0  
 Silt + Clay ( -No.200 ) : 100.0

Approved By : K. E. Walker

Soil No. 1



# SOIL CLASSIFICATION

Project Name : LFUCG Area 3 Pump Station  
 Project No. : 10041433  
 Project County : Lexington  
 Project State : Kentucky  
 Laboratory No. : 10041433  
 Submitted By : HDR  
 Soil Type : Brown Silt

Sample No. : SS-1  
 Sample Loc. : Boring No. PS-3  
 Sample Depth : 2.5' to 4.0'  
 Date Tested : 10/04/16  
 Date Reported : 10/07/16

### AASHTO T27 :

				% Passing	
4	in.	101.6	mm		
3.5	in.	88.9	mm		
3	in.	76.2	mm		
2.5	in.	63.5	mm		
2	in.	50.8	mm		
1 3/4	in.	45	mm		
1 1/2	in.	38.1	mm		
1 1/4	in.	31.5	mm		
1	in.	25	mm		
3/4	in.	19	mm		
1/2	in.	12.5	mm		
3/8	in.	9.5	mm		
1/4		6.3	mm		
No.4		4.75	mm		100.0
No.6		3.35	mm		
No.10		2	mm		100.0

				% Passing	
No.16		1.18	mm		
No.30		0.6	mm		
No.40		0.425	mm		100.0
No.50		0.3	mm		
No.60		0.25	mm		
No.80		0.18	mm		
No.100		0.15	mm		
No.200		0.075	mm		100.0
No.270		0.053	mm		
Hyd. Rd. # 1			mm		
Hyd. Rd. # 2			mm		
Hyd. Rd. # 3			mm		
Hyd. Rd. # 4			mm		
Hyd. Rd. # 5			mm		
Hyd. Rd. # 6			mm		
Hyd. Rd. # 7			mm		

AASHTO T88

CBR : NA  
 Dry Dens. : NA  
 Opt. Moist. : NA

Natural Moisture ( % ) (AASHTO T265) : 30.9

Liquid Limit (AASHTO T89) : 41

Plastic Limit (AASHTO T90) : 41

Plasticity Index : NP

Liquidity Index : NA

Activity : NA

Sp. Gr. (AASHTO T100) : NA

AASHTO Classification: M145 : A-5 (5)

ASTM Classification: D2487 : ML

### AASHTO Composition of Total Sample: M145

Gravel ( 3in. + No.10 ) : 0.0  
 Coarse Sand ( -No.10 + No.40 ) : 0.0  
 Fine Sand ( -No.40 + No.200 ) : 0.0  
 Silt + Clay ( -No.200 ) : 100.0

### ASTM Composition of Total Sample: D2487

Coarse Gravel ( 3in. + 3/4in. ) : 0.0  
 Fine Gravel ( -3/4in. + No.4 ) : 0.0  
 Coarse Sand ( -No.4 + No.10 ) : 0.0  
 Medium Sand ( -No.10 + No.40 ) : 0.0  
 Fine Sand ( -No.40 + No.200 ) : 0.0  
 Silt + Clay ( -No.200 ) : 100.0

Approved By : Ken E. Walker

Soil No. 2

**UNCONFINED COMPRESSION TEST (ROCK CORE)**

---

PROJECT NAME : LFUCG Pump Station	SAMPLE NO. : RS-A
PROJECT NO. : 10041433	SAMPLE LOC. : PS-2
PROJECT COUNTY : Fayette	SAMPLE DEPTH : 42.3' to 42.7'
PROJECT STATE : Kentucky	DATE TESTED : 9/28/2016
LABORATORY NO. : 10041433	DATE REPORTED : 9/30/2016
SUBMITTED BY : HDR   ICA	

---

ROCK DESCRIPTION : Limestone: f. to med. grain, fossiliferous shale laminations, fresh

Diameter : 1.97 in	Area : 3.06 in <sup>2</sup>
Height : 4.00 in	Volume : 0.0071 ft <sup>3</sup>

---

**RESULTS :**

Moisture Air-Dry :	NA
Air-Dry Density :	166.41 lbs/ft. <sup>3</sup>
Maximum Stress :	6278 psi
Elapsed Time :	5:58 min.
Rate of Loading :	60 lb/sec

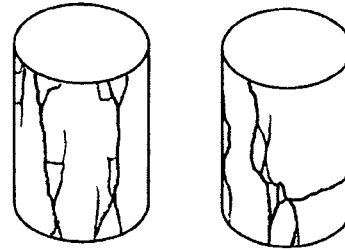

Comments :

Approved By : Ka E Walker

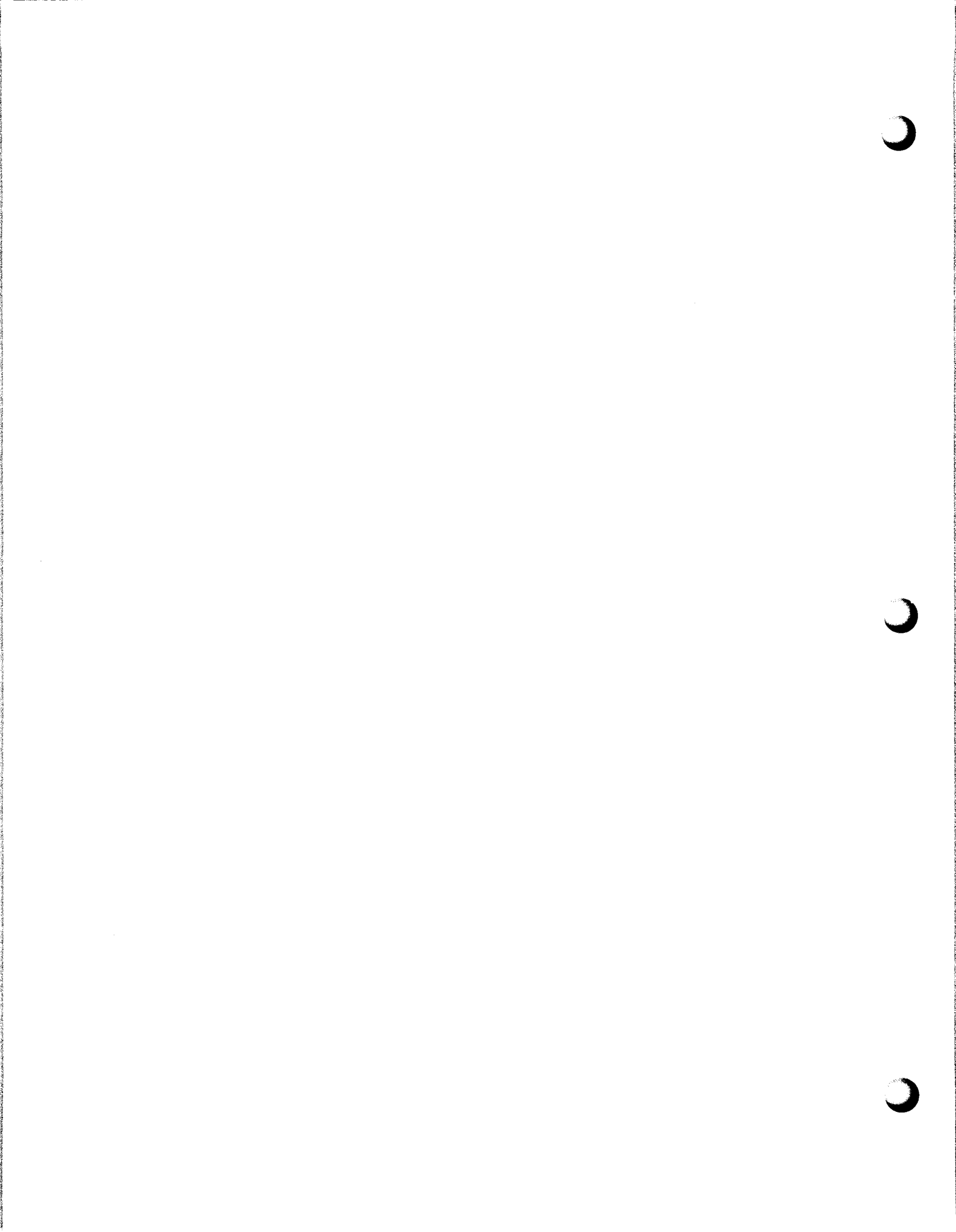





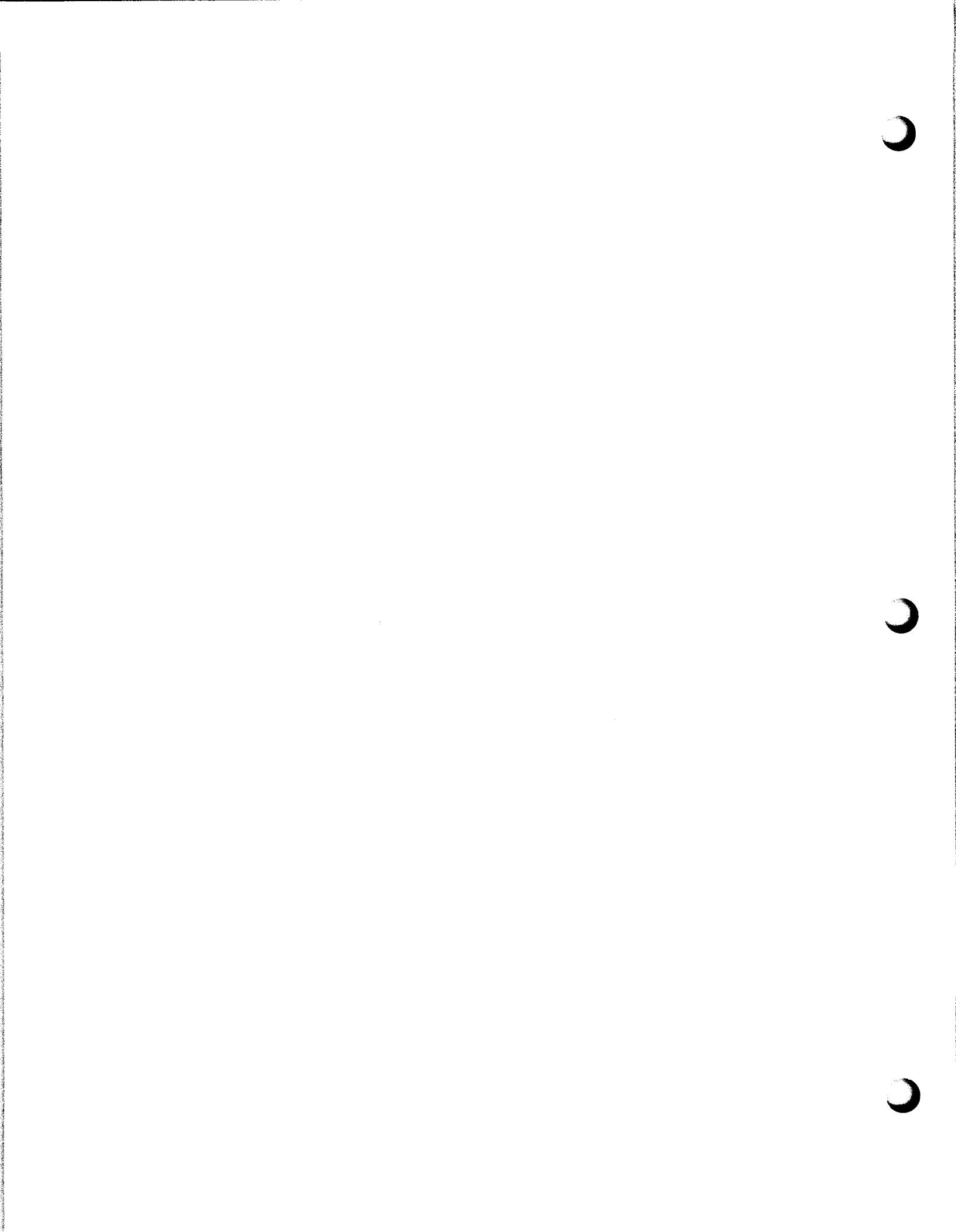



HDR, Inc.  
2517 Sir Barton Way  
Lexington, KY 40509

# SUBSURFACE DIAGRAM LFUCG EA3 Pump Station Borings

CLIENT Lexington Fayette County Urban County Government (LFUCG)

PROJECT NAME Expansion Area 3 (EA3) Pump Station

PROJECT NUMBER 10041433

PROJECT LOCATION Lexington, KY

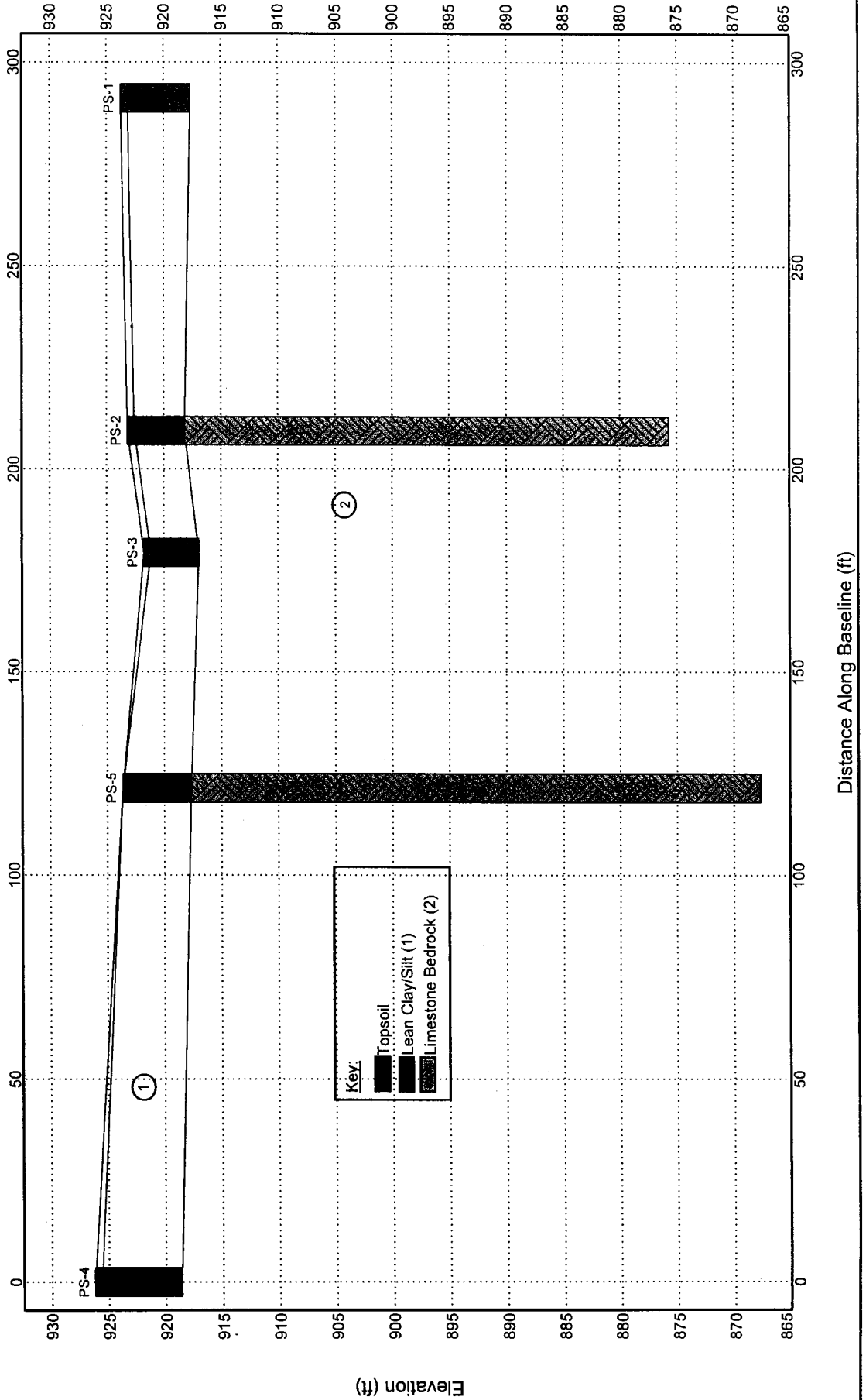

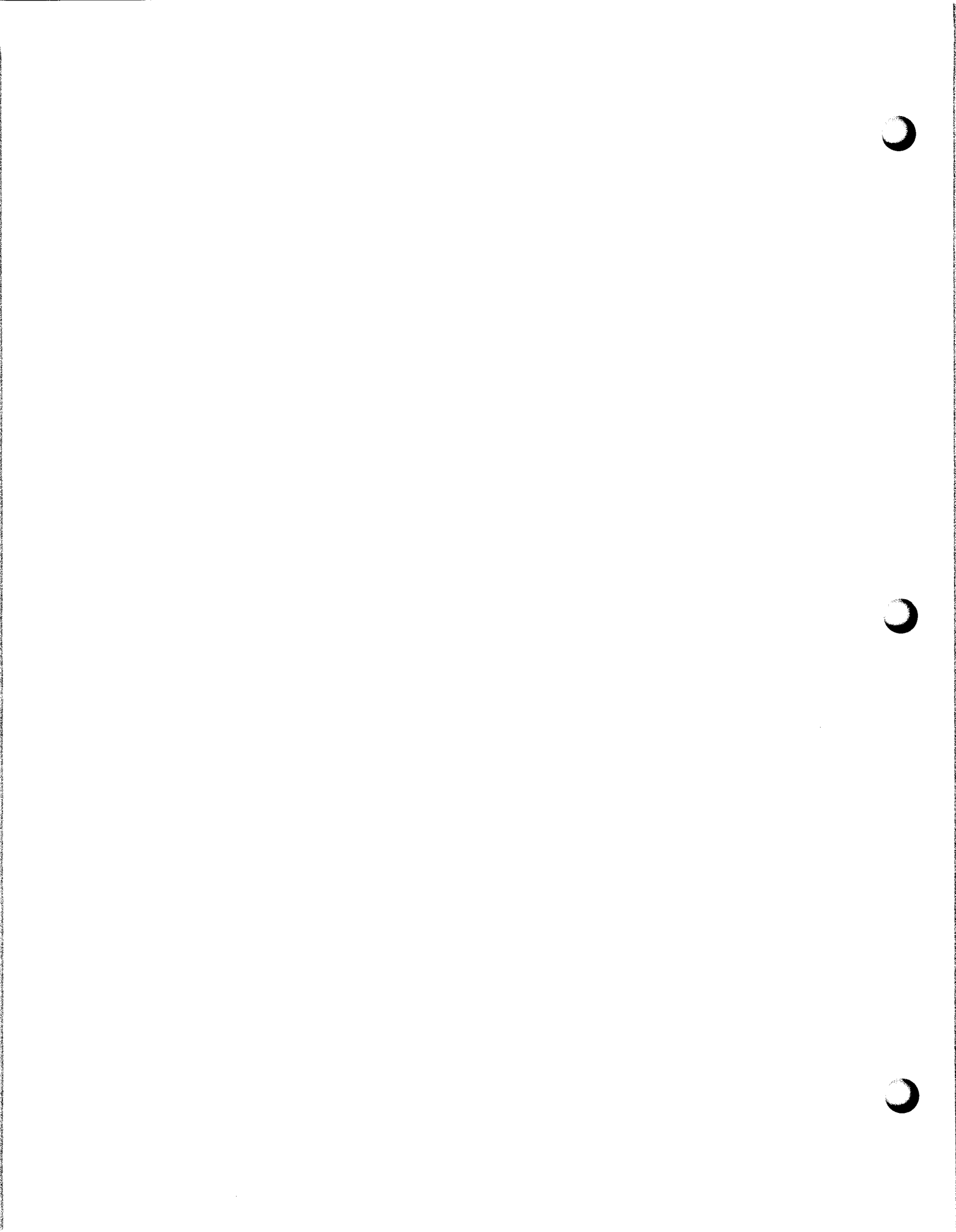

ATTACHMENT E: USGS Seismic Hazard Deaggregation Plots

---



**PSH Deaggregation on NEHRP BC rock  
LFUCG\_EA3\_PS\_84.478° W, 38.105 N.**

Peak Horiz. Ground Accel.  $\geq 0.03310$  g  
 Ann. Exceedance Rate .211E-02. Mean Return Time 475 years  
 Mean  $(R, M, \epsilon_0)$  220.9 km, 6.41, 0.01  
 Modal  $(R, M, \epsilon_0) = 418.1$  km, 7.70, 0.24 (from peak R, M bin)  
 Modal  $(R, M, \epsilon^*) = 418.0$  km, 7.70, 0 to 1 sigma (from peak R, M,  $\epsilon$  bin)  
 Binning: DeltaR 25. km, deltaM=0.2, Delta $\epsilon$ =1.0

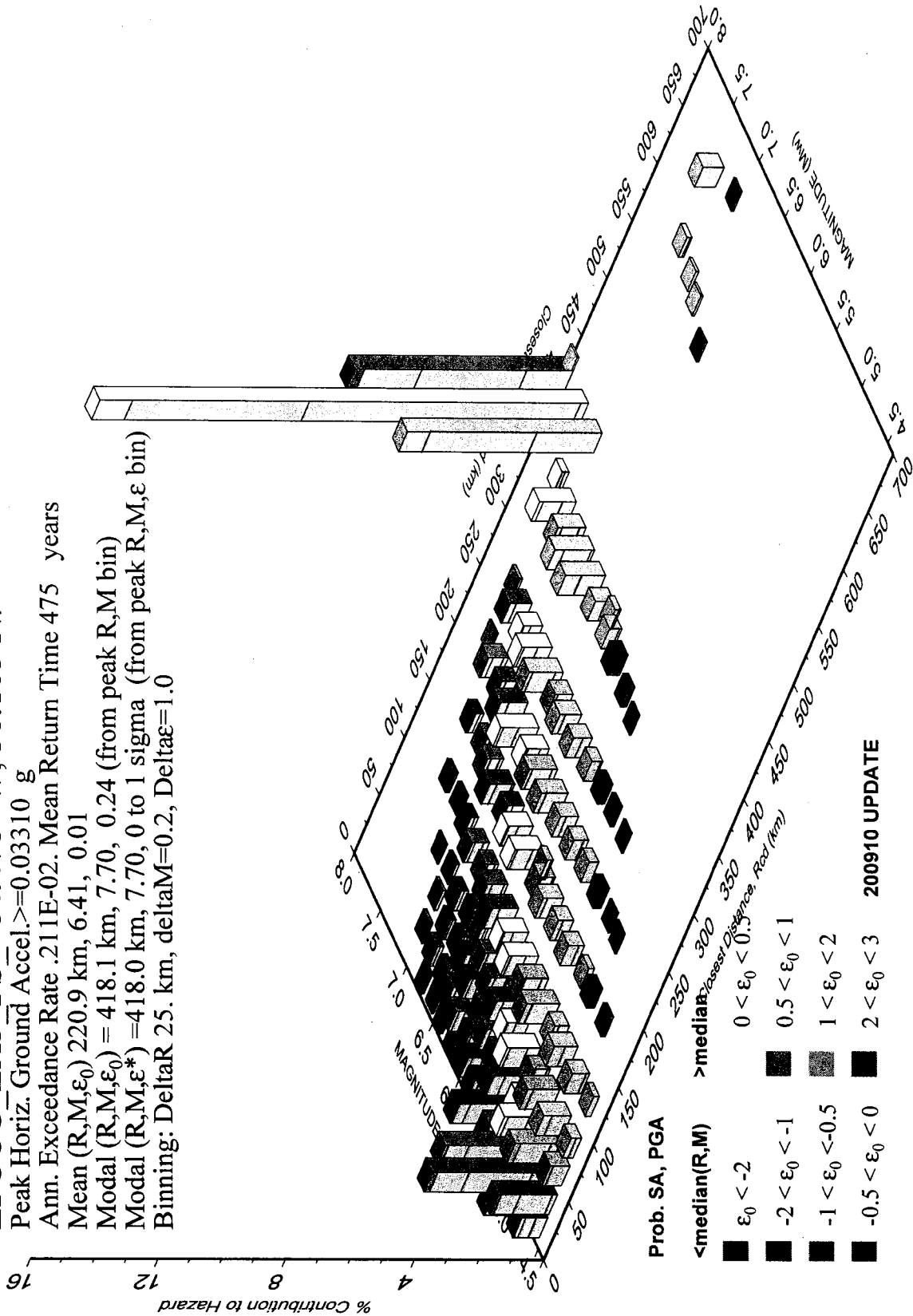

**PSH Deaggregation on NEHRP BC rock  
LFUCG EA3 PS 84.478° W, 38.105 N.**

Peak Horiz. Ground Accel.  $\geq 0.05179$  g  
 Ann. Exceedance Rate .103E-02. Mean Return Time 975 years  
 Mean  $(R, M, \epsilon_0)$  178.8 km, 6.29, 0.16  
 Modal  $(R, M, \epsilon_0) = 418.0$  km, 7.70, 0.92 (from peak R, M bin)  
 Modal  $(R, M, \epsilon^*) = 417.9$  km, 7.70, 1 to 2 sigma (from peak R, M,  $\epsilon$  bin)  
 Binning: DeltaR 25. km, deltaM=0.2, Delta $\epsilon$ =1.0

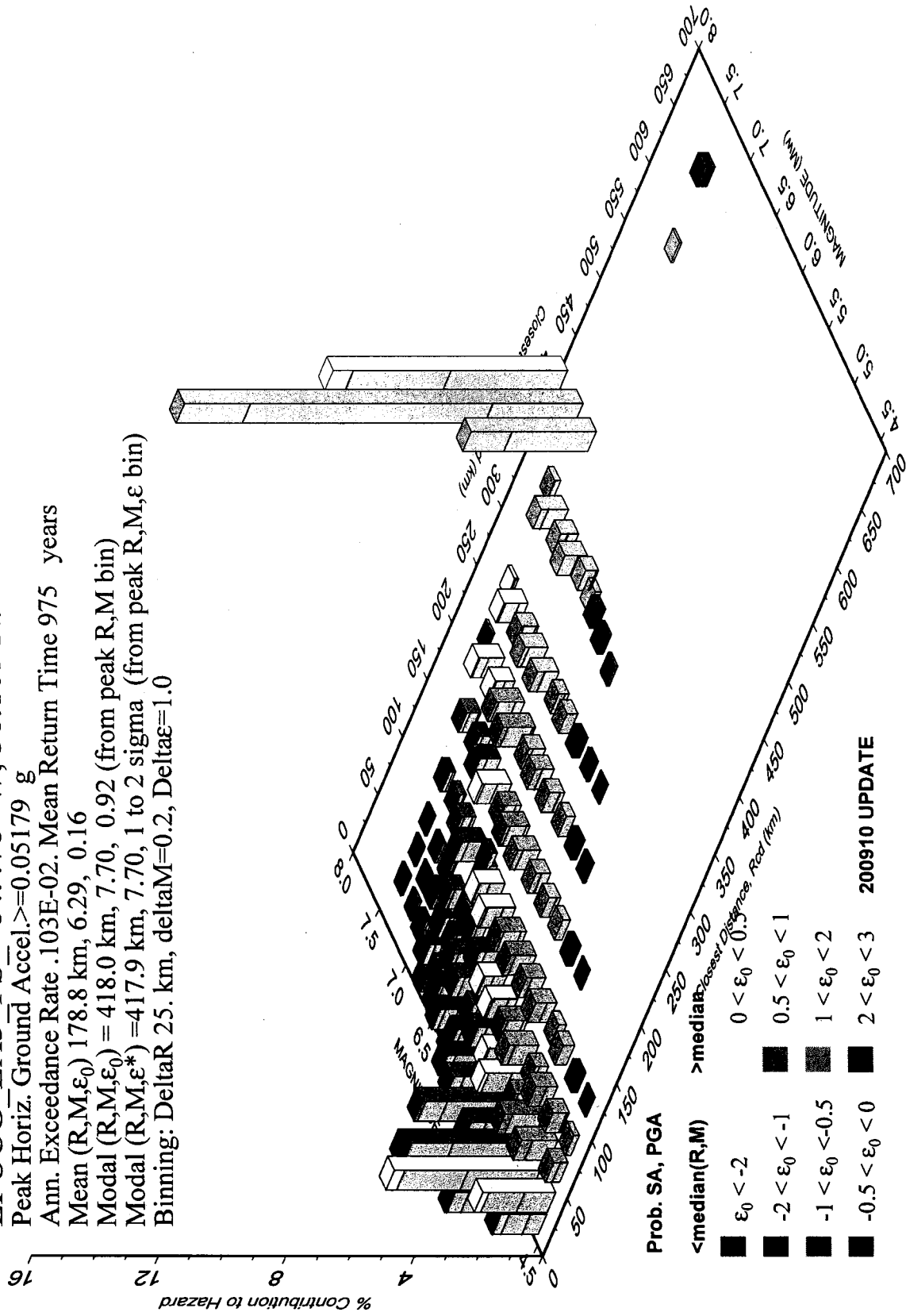



**PSH Deaggregation on NEHRP BC rock  
LFUCG EA3 PS 84.478° W, 38.105 N.**

Peak Horiz. Ground Accel.  $\geq 0.09040$  g  
 Ann. Exceedance Rate .402E-03. Mean Return Time 2475 years  
 Mean  $(R, M, \epsilon_0)$  112.9 km, 6.03, 0.16  
 Modal  $(R, M, \epsilon_0) = 417.9$  km, 7.70, 1.62 (from peak R, M bin)  
 Modal  $(R, M, \epsilon^*) = 418.0$  km, 8.00, 1 to 2 sigma (from peak R, M,  $\epsilon$  bin)  
 Binning: DeltaR 25. km, deltaM=0.2, Delta $\epsilon$ =1.0

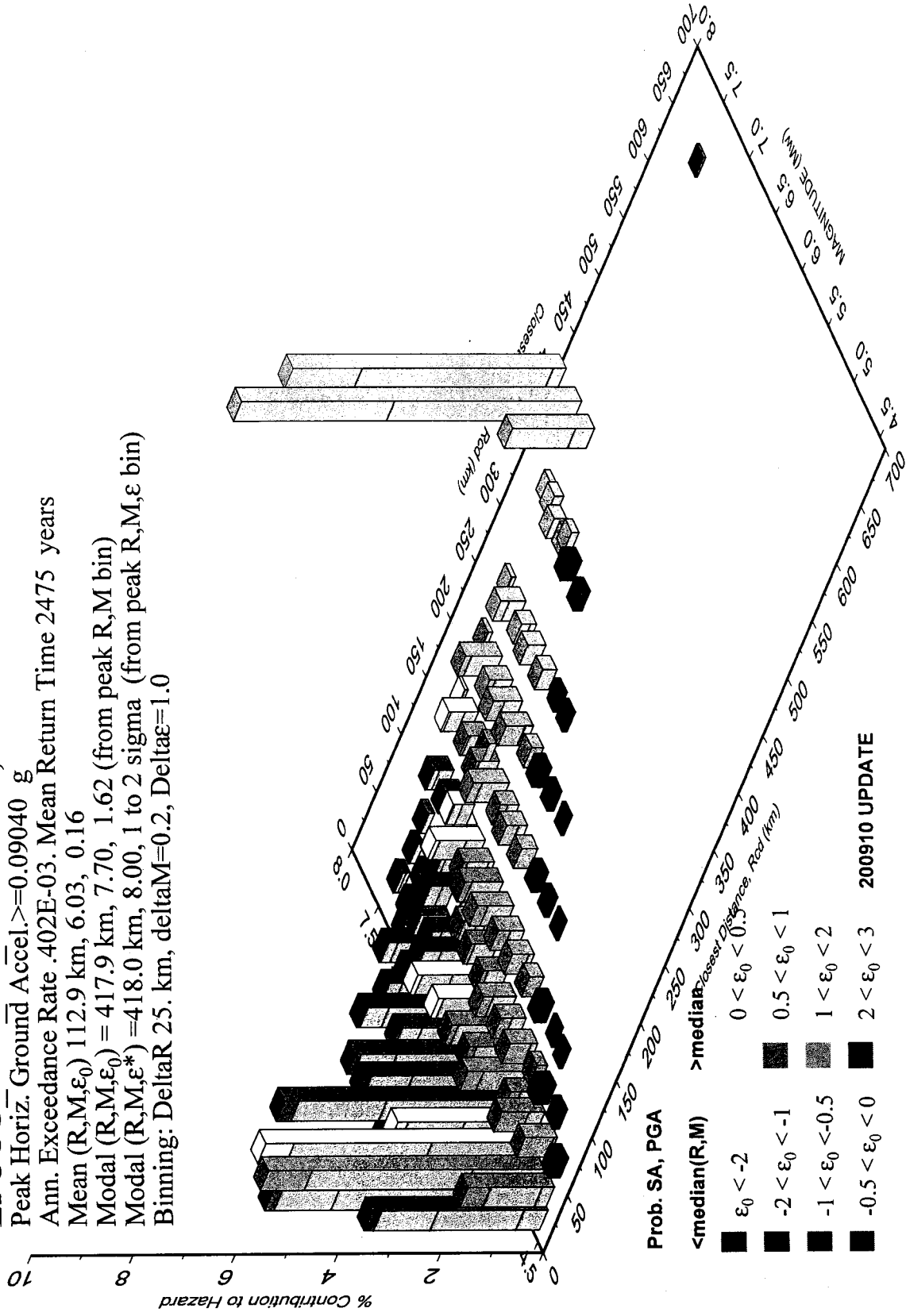



SECTION 00410A – BID FORM

Expansion Area 3 Pump Station Improvements (Contract No. 1)

Division of Water Quality  
Lexington-Fayette Urban County Government

LFUCG Bid No. 160-2017

1.01 GENERAL

Place: Lexington, Kentucky

Date: 09/26/2017

The following Bid Form shall be followed exactly in submitting a Bid for this Work.

This Bid Form Submitted by WRC1, LLC dba W. Rogers Company

649 Bizzell Drive, Lexington KY 40510

(Name and Address of Bidder)

(Hereinafter called "Bidder"), organized and existing under the laws of the State of Delaware, doing

business as Limited Liability Company

"a corporation," "a partnership", or an "individual" as applicable

To: Lexington-Fayette Urban County Government

(Hereinafter called "Owner")

Office of the Director of Central Purchasing

200 East Main Street, Room 338

Lexington, KY 40507

The Bidder, in compliance with your Advertisement for Bids for the **Expansion Area 3 Pump Station Improvements (Contract No. 1)**; Lexington, Kentucky, having examined the Contract Documents including the Plans and Specifications with related documents, having examined the site for proposed Work, and being familiar with all of the conditions and any and all addendums surrounding the construction of the proposed Project, including the availability of materials and labor, hereby proposes to furnish all labor, materials, and supplies, and to construct the Project in accordance with the Contract Documents, within the time set forth therein, and at the lump sum stated hereinafter. These prices are to cover all expenses incurred in performing the Work required under the Contract Documents, of which this Bid is a part. This bid includes the Pump Station, Pump Station site work and access road.

The Bidder hereby agrees to commence Work under this Contract on a date to be specified in a written "Notice to Proceed" of the Owner and to substantially complete the Project within 450 consecutive calendar days. Bidder further agrees to pay liquidated damages, the sum of eight hundred dollars and no cents (\$800.00) for each consecutive day thereafter.

The Bidder hereby acknowledges receipt of the following addenda:

Addendum No. 1 Date 08/11/2017 : Addendum No. 5 Date 09/15/2017

Addendum No. 2 Date 08/24/2017 : Addendum No. 6 Date 09/18/2017

Addendum No. 3 Date 09/07/2017 : Addendum No. 7 Date 09/19/2017

Addendum No. 4 Date 09/08/2017 : Addendum No. 8 Date 09/22/2017

Insert above the number and the date of any Addendum issued and received. If none has been issued and received, the word "NONE" should be inserted.



**ADDENDUM #1**

**Bid Number: #106-2017**

**Date: August 11, 2017**

**Subject: Expansion Area 3 Pump Station (Contract No.1)  
and Force Main (Contract No. 2) Improvements**

**Address inquiries to:  
Brian Marcum  
brianm@lexingtonky.gov  
(859) 258-3325**

**TO ALL PROSPECTIVE SUBMITTERS:**

Please be advised of the following clarifications to the above referenced Bid:

**1. CLARIFICATIONS**

- a. The pre-bid meeting date has been changed to August 24<sup>th</sup>, 2017. For more details see specifications below.
- b. The pre-bid meeting is now mandatory.
- c. The last day to submit questions to purchasing has been changed to September 8<sup>th</sup>, 2017. For more details see specifications below.
- d. The bid submission and open date has been changed to September 21<sup>st</sup>, 2017. For more details see specifications below.

**2. SPECIFICATIONS**

- a. Section 00100, Advertisement for Bids, page 2: Article 1.08 SUBMISSION OF BIDS shall be deleted and replaced with the following:

**"Contractors shall submit their Bids to the Lexington-Fayette Urban County Government, Division of Purchasing, Third Floor, 200 East Main Street, Lexington, Kentucky 40507. Bids shall be submitted in a sealed envelope not later than 2:00 p.m. (local time) September 21, 2017. Sealed proposals shall be marked clearly on the outside of the container "Sealed Proposal for: Expansion Area 3 Pump Station (Contract No. 1) and Force Main (Contract No. 2) Improvements to be opened at 2:00 p.m. Local Time, September 21, 2017. Bids received after the scheduled closing time for receipt of Bids will not be considered and will be returned unopened."**





- b. Section 00100, Advertisement for Bids, page 3: Article 1.11 **PRE-BID MEETING** shall be deleted and replaced with the following:

"A Mandatory pre-Bid meeting will be held at 9:00 a.m. local time, August 24, 2017 at 125 Lisle Industrial Avenue, Tate Bldg. 1<sup>st</sup> Floor, Suite 18, Lexington, KY 40511."

- c. Section 00300, Information Available to Bidders, page 3: Article 1.09 **ADDENDA AND INTERPRETATIONS** shall be deleted and replaced with the following:

"No interpretation of the meaning of the Contract Documents will be made to any Bidder orally. Every request for such interpretation should be in writing addressed to the Director of Central Purchasing, in care of Brian Marcum at [brianm@lexingtonky.gov](mailto:brianm@lexingtonky.gov) (859) 258-3320, who in turn will have an addendum issued for the Lexington-Fayette Urban County Government, and to be given consideration must be received prior to close of business September 8th, 2017. Any and all such interpretations and any supplemental instructions will be in the form of written addenda to the specifications. Acknowledgement of the receipt of addenda must be included with all submitted Bids. Failure of any Bidder to receive any such addendum or interpretation shall not relieve such Bidder from any obligation under his Bid as submitted. All addenda so issued shall become part of the Contract Documents."

*Todd Slatin*

Todd Slatin, Director  
Division of Central Purchasing

All other terms and conditions of the Bid and specifications are unchanged.  
This letter should be signed, attached to and become a part of your Bid.

COMPANY NAME: WRCL, LLC dba W. Rogers Company

ADDRESS: 649 Bizzell Drive, Lexington KY 40510

SIGNATURE OF BIDDER:





ADDENDUM #2

Bid Number: #106-2017

Date: August 24, 2017

Subject: Expansion Area 3 Pump Station (Contract 1) and Force Main  
(Contract 2) Improvements

Address inquiries to:  
Brian Marcum  
(859) 258-3320

TO ALL PROSPECTIVE SUBMITTERS:

Please be advised of the following clarifications to the above referenced bid:

"The EPA forms *are* required to be completed with the bid documents. The subcontractor information must be included on the EPA forms".

Attached find a list of MBE/DBE & Veteran Owned contractors to contact for this project.

Todd Slatin, Director  
Division of Central Purchasing

All other terms and conditions of the RFP and specifications are unchanged. This letter should be signed, attached to and become a part of your submittal.

COMPANY NAME: WRC1, LLC dba W. Rogers Company

ADDRESS: 649 Bizzell Drive, Lexington KY 40510

SIGNATURE OF BIDDER:





ADDENDUM #3

Bid Number: #106-2017

Date: September 7, 2017

Subject: Expansion Area 3 Pump Station (Contract 1) and Force Main  
(Contract 2) Improvements

Address inquiries to  
Brian Marcum  
(859) 258-3320

TO ALL PROSPECTIVE SUBMITTERS:

Please be advised of the following clarifications to the above referenced bid:

The question deadline has been extended to September 12, 2017 at 5:00 PM.

Todd Slatin, Director  
Division of Central Purchasing

All other terms and conditions of the RFP and specifications are unchanged. This letter should be signed, attached to and become a part of your submittal.

COMPANY NAME: WRC1, LLC dba W. Rogers Company

ADDRESS: 649 Bizzell Drive, Lexington KY 40510

SIGNATURE OF BIDDER: 





**ADDENDUM #5**

**Bid Number: #106-2017**

**Date: September 15, 2017**

**Subject: Expansion Area 3 Pump Station (Contract 1) and Force Main  
(Contract 2) Improvements**

**Address inquiries to:  
Brian Marcum  
(859) 258-3320**

**TO ALL PROSPECTIVE SUBMITTERS:**

**Please be advised of the following clarifications to the above referenced bid:**

**The bid opening date has been extended to September 26, 2017 at 2:00 PM EST.**

**Todd Slatin, Director  
Division of Central Purchasing**

**All other terms and conditions of the bid and specifications are unchanged. This letter should be signed, attached to and become a part of your submittal.**

**COMPANY NAME: WRC1, LLC dba W. Rogers Company**

**ADDRESS: 649 Bizzell Drive, Lexington KY 40510**

**SIGNATURE OF BIDDER: [Handwritten Signature]**





MAYOR JIM GRAY



LEXINGTON

TODD SLATA  
DIRECTOR  
CENTRAL PURCHASING

ADDENDUM #6

Bid Number: #106-2017

Date: September 18, 2017

Subject: Expansion Area 3 Pump Station (Contract 1) and Force Main  
(Contract 2) Improvements

Address inquiries to:  
Brian Marcum  
(859) 258-3320

TO ALL PROSPECTIVE SUBMITTERS:

Please be advised of the following clarifications to the above referenced bid:

Please see the attached documents for question responses, clarifications and updated wage rates.

Todd Slatin, Director  
Division of Central Purchasing

All other terms and conditions of the bid and specifications are unchanged. This letter should be signed, attached to and become a part of your submittal.

COMPANY NAME: WRC1, LLC dba W. Rogers Company

ADDRESS: 649 Bizzell Drive, Lexington KY 40510

SIGNATURE OF BIDDER: 



MANOR LIM GRAY



**LEXINGTON**

TODD SLATIN  
DIRECTOR  
CENTRAL PURCHASING

**ADDENDUM #7**

**Bid Number: #106-2017**

**Date: September 19, 2017**

**Subject: Expansion Area 3 Pump Station (Contract 1) and Force Main  
(Contract 2) Improvements**

**Address inquiries to:  
Brian Marcum  
(859) 258-3320**

**TO ALL PROSPECTIVE SUBMITTERS:**

**Please be advised of the following clarifications to the above referenced bid:**

The odor control ductwork is PVC, as shown on the drawings, and FRP as specified in 15892 added in Addendum#6. The material for the ductwork, dampers and transition pieces can be either PVC or FRP.

Todd Slatin, Director  
Division of Central Purchasing

All other terms and conditions of the bid and specifications are unchanged. This letter should be signed, attached to and become a part of your submittal.

COMPANY NAME: WRC1, LLC dba W. Rogers Company

ADDRESS: 649 Bizzell Drive, Lexington KY 40510

SIGNATURE OF BIDDER: \_\_\_\_\_





ADDENDUM #8

Bid Number: #106-2017

Date: September 22, 2017

Subject: Expansion Area 3 Pump Station (Contract 1) and Force Main  
(Contract 2) Improvements

Address inquiries to:  
Brian Marcum  
(859) 258-3320

**TO ALL PROSPECTIVE SUBMITTERS:**

**Please be advised of the following clarifications to the above referenced bid:**

There is a conflict between the Contract Plans and Contract Specifications with respect to force main pipe material from station 10+00 to station 65+51. The Contract Specifications shall prevail. The following pipe materials are approved equals for force main pipe material from station 10+00 to station 65+51.

- Polyvinyl Chloride (PVC)
- Ductile Iron (DI)
- Fiberglass Reinforced Polymer Mortar (FRPM)
- Prestressed Concrete Cylinder Pipe (PCCP)

Todd Slatin, Director  
Division of Central Purchasing

All other terms and conditions of the bid and specifications are unchanged. This letter should be signed, attached to and become a part of your submittal.

COMPANY NAME: WRC1, LLC dba W. Rogers Company



ADDRESS: 649 Bizzell Drive, Lexington KY 40510

SIGNATURE OF BIDDER: \_\_\_\_\_

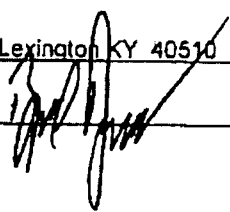
A handwritten signature in black ink, appearing to be a stylized name, is written over the signature line.

1.02 LEGAL STATUS OF BIDDER

Bidder WRC1, LLC dba W. Rogers Company

Date 09/26/2017

~~\*A. A corporation duly organized and doing business under the laws of the State of \_\_\_\_\_  
for whom \_\_\_\_\_, bearing the  
official title of \_\_\_\_\_, whose signature is  
affixed to this Bid is duly authorized to execute contracts.~~

\*B. A Partnership, all of the members of which, with addresses are: (Designate general partners as such)  
WDJ Holdings, LLC 649 Bizzell Drive Lexington KY 40510  
\_\_\_\_\_  
\_\_\_\_\_  
\_\_\_\_\_

~~\*C. An individual, whose signature is affixed to this Bid. (Print name)  
\_\_\_\_\_  
\_\_\_\_\_  
\_\_\_\_\_~~

\* The Bidder shall fill out the appropriate form and strike out the other two.

1.03 BIDDERS AFFIDAVIT

Comes the Affiant, Boyd Rogers, and after being first  
duly sworn, states under penalty of perjury as follows:

- A. His/her name is Boyd Rogers and he/she is the individual submitting the Bid or is the authorized representative of WRC1, LLC dba W. Rogers Company, the entity submitting the Bid (hereinafter referred to as "Bidder").
- B. Bidder will pay all taxes and fees, which are owed to the Lexington-Fayette Urban County Government at the time the Bid is submitted, prior to award of the Agreement and will maintain a "current" status in regard to those taxes and fees during the life of the Agreement.
- C. Bidder will obtain a Lexington-Fayette Urban County Government business license, if applicable, prior to award of the Agreement.
- D. Bidder has authorized the Division of Central Purchasing to verify the above-mentioned information with the Division of Revenue and to disclose to the Urban County Council that taxes and/or fees are delinquent or that a business license has not been obtained.
- E. Bidder has not knowingly violated any provision of the campaign finance laws of the Commonwealth of Kentucky within the past five (5) years and the award of an Agreement to the Bidder will not violate any provision of the campaign finance laws of the Commonwealth.
- F. Bidder has not knowingly violated any provision of Chapter 25 of the Lexington-Fayette Urban County Government Code of Ordinances, known as the "Ethics Act."
- G. Bidder acknowledges that "knowingly" for purposes of this Affidavit means, with respect to conduct or to circumstances described by a statute or ordinance defining an offense, that a person is aware or should have been aware that his/her conduct is of that nature or that the circumstance exists.

Further, Affiant sayeth naught.

*[Handwritten Signature]*  
\_\_\_\_\_  
Affiant Signature

STATE OF Kentucky

COUNTY OF Fayette

The foregoing instrument was subscribed, sworn to and acknowledged before me by

Boyd Rogers on this the 25th day of August, 2011

My Commission expires: February 2012

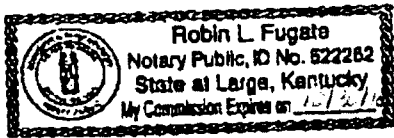

*[Handwritten Signature]*  
\_\_\_\_\_  
NOTARY PUBLIC, STATE AT LARGE

**1.04 BID SCHEDULE**

The Bidder agrees to perform all the Work described in the Specifications and shown on the Plans for the following proposed lump sum, which shall include the furnishing of all labor, materials, supplies, equipment and/or vehicle usage, services, all items of cost, overhead, taxes (federal, state, local), and profit for the Contractor and any Subcontractor involved, within the time set forth herein. If unit prices are applicable, Bidder must make the extensions and additions showing the total amount of Bid. In all cases of discrepancies or math errors the amount written in for the unit price of an item shall govern.

If a lump sum total price is illegible or is omitted, the bid may be determined nonresponsive.

For a lump sum based bid, the item total is the bid amount the Owner uses for bid comparison.

The Owner's decision on the bid amount is final.

Contractor shall complete the bid schedule and deductive alternative.

**EA3 PUMP STATION BID SCHEDULE (Contract No. 1)<sup>1</sup> (SRF Loan Funding)**

<b>B. EA3 Pump Station:</b>					
B1	Base Bid for Construction of the EA3 Pump Station per the Contract Documents, Exclusive of the Following Items	1	LS	\$5,030,000.00	\$5,030,000.00
B2	10-inch Sanitary Sewer	662	LF	\$64.00	\$42,368.00
B3	4-foot Diameter Manhole	3	EA	\$4,736.00	\$14,208.00
B4	4-foot Diameter Drop Manhole	1	EA	\$5,286.00	\$5,286.00
B5	Gravity Sewer Site Restoration: Method B	3,800	SY	\$3.08	\$11,704.00
<b>C. Allowances:</b>					
C1	Control Touch SCADA Integration	1	EA	\$50,000	\$50,000
C2	Project Video Monitoring	1	EA	\$11,000	\$11,000
C3	Miscellaneous Site Improvements	1	EA	\$500,000	\$500,000
C4	Emergency Generator Fuel Tank Permit	1	EA	\$200	\$200
C5	Electrical Service	1	EA	\$10,000	\$10,000
C6	Water Service	1	EA	\$6,000	\$6,000
<b>TOTAL BID (Items B thru C)</b>					

Note: <sup>1</sup> Total Bid (Items B thru C) shall be based on a SRF loan which includes Davis-Bacon wage rates, Good Faith Efforts per EPA requirements, and all American Iron and Steel (AIS) provisions.

**TOTAL BID AMOUNT:**

Five Million Six Hundred Eighty Thousand  
Dollars (\$ 5,680,766.00)

**DEDUCTIVE ALTERNATE '1' (Local Funding):**

Four hundred ninety thousand Dollars (\$ 490,000.00)

Note: '1' Deductive Alternate is the amount of difference between the Bid amount with Davis Bacon wage rates Good Faith Efforts, AIS provisions and the amount without Davis Bacon wage rates, Good Faith Efforts, and AIS provisions.

Respectfully Submitted,

FIRM: WRC1, LLC dba W. Rogers Company

ADDRESS: 649 Bizzell Drive

CITY/STATE/ZIP: Lexington KY 40510

DATE: 09/26/2017

BY:  (must be original signature)

TITLE: Vice President

PHONE: 859-231-6290 FAX: 859-231-6296  
(area code, number & extension)

EMAIL ADDRESS: boydr@wrogers.com

**OFFICIAL ADDRESS AND PHONE:**

649 Bizzell Drive

Lexington KY 40510

859-231-6290 (Seal if Bid is by Corporation)

By signing this form you agree to all of the terms and associated forms.



**1.05 STATEMENT OF BIDDER'S QUALIFICATIONS**

The following statement of the Bidder's qualifications is required to be filled in, executed, and submitted with the Bid:

- A. Name of Bidder: WRC1, LLC dba W. Rogers Company
- B. Permanent Place of Business: 649 Bizzell Drive, Lexington KY 40510
- C. When Organized: 08/30/2016
- D. Where Incorporated: Delaware
- E. Financial Condition:

If specifically requested by the Owner, the apparent low Bidder is required to submit its latest three (3) years audited financial statements to the Owner's Division of Central Purchasing within seven (7) calendar days following the Bid opening.

- F. In the event the Agreement is awarded to the undersigned, Performance, Payment, Erosion and Sediment Control, and Warranty bonds will be furnished by:

Travelers Casualty and Surety Company of America (Surety)

Signed: \_\_\_\_\_ (Representative of Surety)

- G. The following is a list of similar projects performed by the Bidder. (Attach separate sheet if necessary).

<u>NAME</u>	<u>LOCATION</u>	<u>CONTRACT SUM</u>
<u>See Attached Documentation</u>	_____	_____
_____	_____	_____
_____	_____	_____
_____	_____	_____
_____	_____	_____

- H. The Bidder has now under contract and bonded the following projects.

<u>NAME</u>	<u>LOCATION</u>	<u>CONTRACT SUM</u>
<u>See Attached Documentation</u>	_____	_____
_____	_____	_____
_____	_____	_____
_____	_____	_____
_____	_____	_____

### Completed Projects 2005 through 2016

Job No	Project Name	Owner	Engineer	Original Contract Amount	Year Completed
326	Oostanaula Wastewater Treatment Plant Athens, Tennessee	Athens Utility Board 100 Englewood Road Athens, Tennessee 37303 Contact: Jill Davis 423/745-4501	Barge, Waggoner, Sumner & Cannon 1st Tennessee Plaza, Suite 2400 Knoxville, Tennessee 37929 Contact: John Burns, PE 423/673-2810	\$15,433,000	2005
327	Contract 1 Water Treatment Plant Wellington, Kentucky	Cave Run Water Commission P.O. Box 1070 Wellington, Kentucky 40360 Contact: Kevin McGuire 606/674-9356	Cann-Tech, LLC 201 South Main Street Lawrenceburg, Kentucky 40342 Contact: Larry Cann 502/859-0907	\$5,579,244	2005
329	Water Treatment Plant Cave City, Kentucky	Green River Valley Water District 85 East Les Turner Road Cave City, Kentucky 42127 270/773-2135	Water Management Services 111 Bush Road Nashville, Tennessee 37217 Contact: Joe Hinkle 615/366-6088	\$4,346,300	2005
331	Wastewater Treatment Plant Expansion Shelbyville, Kentucky	Shelbyville Municipal Water and Sewerage Commission 1059 Washington Street Shelbyville, Kentucky 40065 502/633-2840	Quest Engineers, Inc. 2517 Sir Barton Way Lexington, Kentucky 40509 Rob Williams, PE 859/223-3755	\$3,705,900	2006
332	South Hopkins Wastewater Treatment Plant Nortonville, Kentucky	City of Nortonville 199 South Main Street Nortonville, Kentucky 42442 270/676-3384	McGhee Engineering, Inc. 202 Ewing Street Guthrie, Kentucky 42234 Contact: Mike McGhee, PE 270/463-9985	\$4,427,000	2006
333	McCroskey Island Water Treatment Plant Sevierville, Tennessee	Sevierville Water System 116 Church Street Sevierville, TN 37862 Contact: Steven Flynn 865/453-5522	Jordan Jones & Goulding, Inc. 6801 Governors Lake Parkway Norcross, GA 30071 Contact: Wendy Creek PE 678/333-0331	\$17,303,300	2007

## Completed Projects 2005 through 2016

Job No	Project Name	Owner	Engineer	Original Contract Amount	Year Completed
334	Alcoa Water Treatment Plant Maryville, Tennessee	Department of Public Works 1024 Springbrook Road Alcoa, TN 37701 Contact: Mr. Kenny Wiggins, PE 865/380-4802	Smith Seckman Reid, Inc. 2995 Slicko Drive Nashville, TN 37204 Contact: Mr. Mike Bernard, PE 615/383-1113	\$24,329,000	2007
335	Strodes Creek Wastewater Treatment Plant Winchester, Kentucky	Winchester Municipal Utilities 150 North Main Street Winchester, KY 40391 Contact: Mr. Mike Flynn 859/744-5434	CDP Engineers, Inc. 3250 Blazer Parkway Lexington, KY 40509 Contact: Mr. Ken Roseman PE 859/264-7500	\$18,785,000	2008
338	Raw Water Intake Note: WRC Served as Completion Contractor After Owner Terminated Original Contractor For Convenience	Bowling Green Municipal Utilities 801 Center St. Bowling Green, KY 42101 Contact: Mr. Michael Gardner 270/782-1220	Water Management Services 111 Bush Road Nashville, Tennessee 37217 Contact: Joe Hinkle 615/366-6088	Performed Cost Plus Fixed Fee Final Total @ \$3,196,000	2007
340	Raw Water Intake Cadtz, Kentucky	Hopkinsville Environmental Water Authority 401 East Ninth St. Hopkinsville, KY 42241 Contact: Mr. Derrick Watson 270/887-4246	JV Engineering 5100 Linbar Dr., Suite 106 Nashville, TN 37211 Contact: Mr. Jeff Vaughan 615/781-8725	\$6,028,000	2009
342	North Elkhorn Pump Station Lexington, Kentucky	Lexington Fayette Urban Co Govt Construction Management 301 Lisle Industrial Ave. Lexington, KY 40511 Contact: Mr. Rick Day 859/254-7787	GRW Engineers, Inc. 801 Corporate Drive Lexington, Kentucky 40503 Contact: Joe Henry, PE 859/223-3999	\$4,008,000	2009
343	Northwest Wastewater Treatment Plant Collierville, Tennessee	Town of Collierville 500 Poplar View Parkway Collierville, Tennessee 38017 Contact: Derek Honeycutt 901/457-2360	Allen & Hoshall 9850 Kingston Pike, Suite 300 Knoxville, TN 37922 Contact: Ben Pearson, PE 865/693-7881	\$19,992,000	2009

### Completed Projects 2005 through 2016

Job No	Project Name	Owner	Engineer	Original Contract Amount	Year Completed
344	Contract 1 - Ohio County Regional WWTP Beaver Dam, Kentucky	Ohio County Regional WW District 1350 Clay Street Hartford, Kentucky 42347 Contact: Jon Lawson 270/274-5678	Quest Engineers, Inc. 2517 Sir Barton Way Lexington, Kentucky 40509 Contact: Rob Williams, PE 859/223-3755	\$9,172,000	2008
348	Regional Wastewater Treatment Plant Johnson City, Tennessee	City of Johnson City 601 E. Main Street Johnson City, Tennessee 37601 Contact: Tom Wiltherspoon 423/461-1640	Smith Seckman Reid, Inc. 2995 Sidco Drive Nashville, Tennessee 37204 Contact: Herby Rader, PE 615/383-1113	\$23,660,529	2010
353	Contract H Water Treatment Plant Expansion to 51 MGD Nashville, Tennessee	Harpeth Valley Utility District 5910 River Rd. Nashville, TN 37209 Contact: Mr. John Barnes 615/354-8536	J&G/Jacobs One Vanlage Way, Suite B-400 Nashville, Tennessee 37228 Contact: Brent Fulghum, PE 615/254-6002	\$14,568,700	2010
354	Turkey Creek Wastewater Treatment Plant Improvements Knoxville, Tennessee	First Utility District of Knox County 122 Durwood Road Knoxville, Tennessee 37922 Contact: Wayne Watson 865/986-9741	J&G/Jacobs 9721 Cogdill Road, Suite 201 Knoxville, Tennessee 37932 Contact: Ken Bryson, PE 865/696-1948	\$18,637,641	2010
355	Kentucky River Pool #3 Water Treatment Plant Owenton, Kentucky <i>Note: For this project only W. Rogers Company was in a joint venture with Reynolds, Inc of Oheans, IN under the entity name of Reynolds-Rogers, LLC. Stated contract amount represents WRC portion.</i>	Kentucky American Water Company 2300 Richmond Road Lexington, Kentucky 40502 Contact: Linda Bridwell 859/269-2395	Gannell Fleming, Inc. 207 Senale Avenue Camp Hill, Pennsylvania 17011 Contact: Jeffrey Raffensperger, PE 717/763-7211	\$27,744,848	2010
356	Paducah Wastewater Treatment Plant Improvements Paducah, Kentucky	Paducah-McCracken USA 621 Northview St. Paducah, KY 42001 Contact: Mr. John Hodges 270/444-0206	GRW Engineers, Inc. 801 Corporate Drive Lexington, Kentucky 40503 Contact: Alan Bryan, PE 859/223-3999	\$4,153,000	2010

### Completed Projects 2005 through 2016

Job No	Project Name	Owner	Engineer	Original Contract Amount	Year Completed
357	Contract 4-08-2 Middle Fork WWTP Expansion Jackson, Tennessee	Jackson Energy Authority 119 E. College St. Jackson, TN 38301 Contact: Mr. Rowland Fisher 731/422-7376	J.R. Waulford & Company 50 Volunteer Blvd. Jackson, TN 38305 Contact: Mr. D.E. Crowell, P.E. 731/868-1853	\$4,690,000	2010
358	Wastewater Treatment Plant Additions and Modifications Lebanon, Tennessee	City of Lebanon Dept. of Public Works Administration Building 200 Casle Heights Ave North, Ste. 300 Lebanon, Tennessee 37087 Contact: Jeff Baines 615/443-2824	Water Management Services, LLC 2 International Plaza, Suite 401 Nashville, Tennessee 37217 Contact: Joe Hinkle 615/366-6088	\$14,675,750	2010
360	Contract 1 Water Treatment Plant Expansion Liberty, Kentucky	City of Liberty 518 Middleburg St. Liberty, KY 42539 Contact: Mr. Steve Sweeney 606/787-9973	GRW Engineers, Inc. 801 Corporate Drive Lexington, Kentucky 40503 Contact: Laura Gilkerson, PE 859/223-3999	\$5,350,000	2010
361	Contract 344-07-02 Water Treatment Facilities Upgrade Berea, Kentucky	City of Berea 200 Harrison Road Berea, Kentucky 40403 Contact: Donald Blackburn 859/986-4391	Bell Engineering 234 Waller Avenue Lexington, Kentucky 40504 Contact: Ron McMaine 859/278-5412	\$8,019,912	2010
362	Valley Creek Wastewater Treatment Plant Elizabethtown, Kentucky	City of Elizabethtown 200 West Dixie Avenue Elizabethtown, Kentucky 42701 Contact: Scott Fiepke, PE 270/373-7733	HDR/Quest Engineers, Inc. 2517 Sir Barton Way, Lexington, KY 40509 Contact: Benton Hanson, PE 859/223-3755	\$20,115,753	2011
363	Pilman Creek Wastewater Treatment Plant Expansion Somerset, Kentucky	City of Somerset 105 College Street Somerset, Kentucky 42501 Contact: Charlie Dick, Manager 606/678-4466	HDR/Quest 2517 Sir Barton Way Lexington, Kentucky 40509 Contact: Tom Schaffer, PE 859/223-3755	\$12,687,000	2012

## Completed Projects 2005 through 2016

Job No	Project Name	Owner	Engineer	Original Contract Amount	Year Completed
365	Contract 308 - Wastewater Treatment Plant 2 Monteagle, Tennessee	City of Monteagle 16 Dixie Lee Avenue Monteagle, Tennessee 37356 Contact: Charles Rollins, Mayor	James C. Hailey & Company 2622 Old Lebanon Road Nashville, Tennessee 37214 Contact: Neal Westerman, PE 615/883-4993	\$4,076,000	2011
367	Wastewater Treatment Plant Expansion City of Mt. Washington, Kentucky	City of Mt. Washington 275 Snapp Street Mt. Washington, Kentucky 40047 Contact: Joella Calhoun, Mayor 502/538-4216	Derrick Engineering, Inc. 1397 South Third Street Louisville, Kentucky 40208 Contact: David Derrick, PE 502/636-9273	\$12,944,000	2012
370	Stage 2 Disinfection/Disinfection Byproducts Reduction Improvements Kokomo, Indiana and Richmond, Indiana Indiana American Water Company <i>Note: This is a Design Build Project.</i>	Indiana American Water Company 555 E. County Line Road, Suite 201 Greenwood, Indiana 46143 Contact: Sachin G. Pradhan, EIT 317/885-2423	Design provided by GRW Engineers via D/B subcontract to W. Rogers Company	\$4,147,693	2011
372	Water Treatment Plant Expansion to 28 MGD Clarksville, Tennessee <i>Note: 28 MGD Pall Membrane Facility</i>	Clarksville Water & Gas Department 2215 Madison Avenue Clarksville, Tennessee 37043 Contact: Chris Lambert 931/645-1857	JJ&G/Jacobs 6801 Governors Lake Pkwy, Bldg. 200 Norcross, Georgia 30071 Contact: Wendy Creek, PE 770/455-8555	\$24,882,875	2014
374	Wastewater Treatability Improvements (WWW06) Capital Improvements Program Fort Campbell Army Base Fort Campbell, Kentucky <i>Note: WRC Serving as Subcontractor to CH2M Hill Constructors under D/B Contract with Owner</i>	CH2M Hill Constructors 5101 Tennessee Avenue Fort Campbell, Kentucky 42223 Contact: Bruce Brown 609/915-2562	CH2M Hill Constructors 5101 Tennessee Avenue Fort Campbell, Kentucky 42223 Contact: Bruce Brown 609/915-2562	\$11,926,231	2013
375	Phase 2 Improvements Water Reclamation Facility LeSourdsville, Ohio	Butler County Water & Sewer 130 High Street Hamilton, Ohio 45011 Contact: Steve Seitz 513/785-6370	Hazen & Sawyer, P.C. 11311 Cornell Park Drive, Suite 135 Cincinnati, Ohio 45242 Contact: Tom Schaffer, PE 513/469-5140	\$34,232,850	2015

## Completed Projects 2006 through 2016

Job No	Project Name	Owner	Engineer	Original Contract Amount	Year Completed
378	Water Treatment Plant Expansion Harrodsburg, Kentucky	City of Harrodsburg 208 South Main Street Harrodsburg, KY 40330 Contact: Wally Bottoms 859/613-5122	GRW Engineers, Inc. 801 Corporate Drive Lexington, Kentucky 40503 Contact: Mr Ryan Carr, PE 859/223-3999	\$9,360,000	2013
379	T. E. Maxson WWTP Improvements Maxson Fine Bar Screen Memphis, Tennessee	City of Memphis 125 North Main Street, Room 620 Memphis, TN 38103-2091 Contact: Scott Morgan, P.E. 901-576-7125	AECOM 220 Athens Way, Suite 200 Nashville, TN 37228-1352 Contact: Robert Stoll, PE 615/224-8864	\$3,882,000	2013
380	Water Treatment Plant Expansion to 20 MGD Loudon, Tennessee	Loudon Utilities Board 201 Alma Place Loudon, Tennessee 37774 Contact: Lynn Mills 865/458-2091	J&G/Jacobs 8801 Governors Lake Pkwy, Bldg. 200 Norcross, Georgia 30071 Contact: Wendy Creek, PE 770/455-8555	\$9,229,005	2015
381	Wastewater Treatment Plant Improvements Clarksville, Tennessee Bid No. 2850 Electrical & HVAC Improvements	Clarksville Water & Gas Department 2215 Madison Avenue Clarksville, Tennessee 37043 Contact: Pat Hickey, General Manager 931/845-1857	Hazen & Sawyer 227 French Landing Drive, Suite 420 Nashville, Tennessee 37228 Contact: Brent Fulghum, PE 615/483-9537	\$4,898,764	2014
382	Wolf Run Pump Station Lexington, Kentucky	Lexington-Fayette Urban Co Government 200 E. Main Street Lexington, Kentucky 40507 Contact: Mr. Rick Day 859/425-2407	HDR Engineering, Inc. 2517 Sir Barton Way Lexington, Kentucky 40509 Contact: Mark Stephens 859/223-3755	\$4,313,000	2014
385	Wei Weather Detention Facilities Frankfort, Kentucky	City of Frankfort Sewer Department 315 W. Second Street Frankfort, KY 40601 Contact: Bob Peterson 502/875-2448	GRW Engineers, Inc. 801 Corporate Drive Lexington, KY 40503 Contact: John Martin, PE 859/223-3999	\$7,329,000	2015
388	Water Treatment Plant Expansion Lexington, Kentucky Construction Manager @ Risk in Joint Venture with Cobra Industrial Services	Kentucky American Water Company 2300 Richmond Road Lexington, KY 40502 Contact: Brent O'Neill 859/268-6316	Hazen & Sawyer 444 Lewis Hargett Circle, Suite 260 Lexington, Kentucky 40503 Contact: Bret Casey, PE 614/781-9655	\$6,036,433	2016

**Uncomplete Projects Currently Under Contract**

Project Name	Owner	Engineer	Contract Date	Cost of Work
1753001 KAW KRS1 Valve Houses 3,4,5 Lexington KY	Kentucky American Water Company 2300 Richmond Road Lexington KY 40502	HDR Engineering, Inc. 2517 Sir Barton Way Lexington KY 40509 859-629-4800	11/1/2016	\$ 621,726.00
1753002 KAW Jacobson Park Booster Station Lexington KY	Kentucky American Water Company 2300 Richmond Road Lexington KY 40502	Stanlec Consulting Services, Inc. 3052 Beaumont Centre Circle Lexington KY 40513	2/1/2017	\$ 685,850.00
1753004 UT Substation - Knoxville TN Knoxville TN	University of Tennessee Knoxville TN	Vreeland Engineers, Inc. 3107 Sultherland Avenue Knoxville TN 37919	3/27/2017	\$ 287,500.00
1753013 Liberty KY WWTP Liberty KY	City of Liberty 518 Middleburg Street Liberty KY 42539	GRW Engineers, Inc. 801 Corporate Drive Lexington KY 40503	4/3/2017	\$ 3,838,343.00
1753014 UK RB#2 - Spiline Utilities Lexington KY	University of Kentucky Lexington KY	Champlin Architecture 720 East Pete Rose Way, Ste. 140 Cincinnati, OH 45202	4/3/2017	\$ 4,993,000.00
1753015 Murray Cleanwell & High Service PS Murray Kentucky	City of Murray 104 North Fifth Street Murray KY 42071	Strand Associates, Inc. 325 West Main Street, Ste. 710 Louisville KY 40202	5/5/2017	\$4,152,000.00



I. List Key Bidder Personnel who will work on this Project.

<u>NAME</u>	<u>POSITION DESCRIPTION</u>	<u>NO. OF YEARS WITH BIDDER</u>
<u>Warren Rogers</u>	<u>President</u>	<u>45</u>
<u>Boyd Rogers</u>	<u>Vice President</u>	<u>41</u>
<u>Michael Bailey</u>	<u>Project Manager</u>	<u>15</u>
<u>Mac Foster</u>	<u>Foreman</u>	<u>34</u>
_____	_____	_____

J. MWDBE Participation on current bonded projects under contract:

<u>SUBCONTRACTORS (LIST)</u>	<u>PROJECT (SPECIFIC TYPE)</u>	<u>MWDBE</u>	<u>% of WORK</u>
<u>Bison Services</u>	<u>Liberty WWTP</u>	<u>MBE</u>	<u>3</u>
_____	_____	_____	_____
_____	_____	_____	_____
_____	_____	_____	_____
_____	_____	_____	_____
_____	_____	_____	_____

(USE ADDITIONAL SHEETS IF NECESSARY)

K. We acknowledge that, if we are the apparent low Bidder, we may be required to submit to the Owner within seven (7) calendar days following the Bid Opening, a sworn statement regarding all office management and field management personnel. Additionally, if requested by the Owner, we will within seven (7) days following the request submit audited financial statements and loss history for insurance claims for the three (3) most recent years (or a lesser period if stipulated by the Owner)

1.06 LIST OF PROPOSED SUBCONTRACTORS (Base Bid)

The following list of proposed subcontractors is required by the Owner to be executed, completed and submitted with the Bid Form. All subcontractors are subject to approval of the Lexington-Fayette Urban County Government. Failure to submit this list completely filled out may be cause for rejection of Bid.

BRANCH OF WORK** (List each major item)	SUBCONTRACTOR	MWDBE (yes/no)	% of WORK
1. <u>electrical</u>	Name: <u>Jordan Electric</u>	<u>no</u>	<u>10%</u>
	Address: <u>2321 Maggard Dr.</u> <u>Lexington</u>		
2. <u>plumbing</u>	Name: <u>Wightworth Plumbing</u>	<u>no</u>	<u>1%</u>
	Address: <u>54 1/2 Stewart Rd.</u> <u>Lexington</u>		
3. <u>HVAC</u>	Name: <u>Keating &amp; Sons</u>	<u>no</u>	<u>2%</u>
	Address: <u>1126 Prospect Street</u> <u>Indianapolis IN</u>		
4. <u>roofing</u>	Name: <u>Kalkreuth Roofing</u>	<u>no</u>	<u>2%</u>
	Address: <u>Drawer</u> <u>PO Box 4399</u> <u>Winning WV</u>		
5. _____	Name: _____	_____	_____
	Address: _____		
6. _____	Name: _____	_____	_____
	Address: _____		

\*\* Such as: Grading, bituminous paving, concrete, seeding and protection, construction staking, etc

1.06 LIST OF PROPOSED SUBCONTRACTORS (Deductive Alternate - IF different from Base Bid)

The following list of proposed subcontractors is required by the Owner to be executed, completed and submitted with the Bid Form. All subcontractors are subject to approval of the Lexington-Fayette Urban County Government. Failure to submit this list completely filled out may be cause for rejection of Bid.

<u>BRANCH OF WORK**</u> (List each major item)	<u>SUBCONTRACTOR</u>	<u>MWDBE (yes/no)</u>	<u>% of WORK</u>
1. <u>electrical</u>	Name: <u>Arroy Electric</u> Address: <u>2321 Mcgarrard Dr.</u> <u>Lexington, KY</u>	<u>no</u>	<u>10%</u>
2. <u>Plumbing</u>	Name: <u>Wicksworth Plumbing</u> Address: <u>5434 Stewart Rd.</u> <u>Lexington</u>	<u>no</u>	<u>10%</u>
3. <u>HVAC</u>	Name: <u>Kunring &amp; Sons</u> Address: <u>1126 Prairie St.</u> <u>Indianapolis IN</u>	<u>no</u>	<u>2%</u>
4. <u>Roofing</u>	Name: <u>Kalkreuth Roofing</u> Address: <u>PO Drawer 6399</u> <u>Wheeling WV</u>	<u>no</u>	<u>2%</u>
5. _____	Name: _____ Address: _____	_____	_____
6. _____	Name: _____ Address: _____	_____	_____

\*\* Such as: Grading, bituminous paving, concrete, seeding and protection, construction staking, etc.

**1.07 AUTHENTICATION OF BID AND STATEMENT OF NON-COLLUSION AND NON-CONFLICT OF INTEREST**

I hereby swear (or affirm) under the penalty for false swearing:

- A. That I am the Bidder (if the Bidder is an individual), a partner of the Bidder (if the Bidder is a partnership), or an officer or employee of the Bidding corporation having authority to sign on its behalf (if the Bidder is a corporation);
- B. That the attached Bid has been arrived at by the Bidder independently, and has been submitted without collusion with, and without any agreement, understanding or planned common course of action, with any other contractor, vendor of materials, supplies, equipment or services described in the Advertisement for Bid, designed to limit independent bidding or competition;
- C. That the contents of the Bid or Bids have not been communicated by the Bidder or its employees or agents to any person not an employee or agent of the Bidder or its surety on any bond furnished, with the Bid or Bids, and will not be communicated to any such person, prior to the official opening of the Bid or Bids;
- D. That the Bidder is legally entitled to enter into the contracts with the Lexington-Fayette Urban County Government, and is not in violation of any prohibited conflict of interest;
- E. (Applicable to corporation only) That as a foreign corporation, we are registered with the Secretary of State, Commonwealth of Kentucky, and authorized to do business in the State \_\_\_\_\_ or, that as a domestic corporation, we are in good standing with the Secretary of State, Commonwealth of Kentucky \_\_\_\_\_. [Check the statement applicable.]
- F. This offer is for ninety (90) calendar days from the date this Bid is opened. In submitting the above, it is expressly agreed that, upon proper acceptance by the Lexington-Fayette Urban County Government of any or all items Bid above, an Agreement shall thereby be created with respect to the items accepted.
- G. That I have fully informed myself regarding the accuracy of the statements made in this statement.
- H. That I certify that Subcontractors have not and will not be awarded to any firm(s) that have been debarred from noncompliance with the Federal Labor Standards, Title VI of the Civil Rights Act of 1964 As Amended, Executive Order 11246 As Amended or any other Federal Law.

WRC1, LLC dba W. Rogers Company     09/26/2017  
 Company     Date

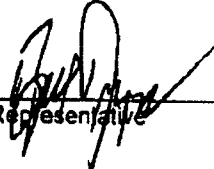
  
 Representative

1.08 STATEMENT OF EXPERIENCE

NAME OF INDIVIDUAL: See Attached Resumes

POSITION/TITLE: \_\_\_\_\_

STATEMENT OF EXPERIENCE: \_\_\_\_\_  
\_\_\_\_\_

NAME OF INDIVIDUAL: \_\_\_\_\_

POSITION/TITLE: \_\_\_\_\_

STATEMENT OF EXPERIENCE: \_\_\_\_\_  
\_\_\_\_\_

NAME OF INDIVIDUAL: \_\_\_\_\_

POSITION/TITLE: \_\_\_\_\_

STATEMENT OF EXPERIENCE: \_\_\_\_\_  
\_\_\_\_\_

NAME OF INDIVIDUAL: \_\_\_\_\_

POSITION/TITLE: \_\_\_\_\_

STATEMENT OF EXPERIENCE: \_\_\_\_\_  
\_\_\_\_\_

\* Include all officers, office management, Affirmative Action officials, and field management personnel.  
Attach separate sheets if necessary

**WARREN P. ROGERS**



**W.  
ROGERS  
COMPANY**

**Education:** Bachelor of Business Administration  
University of Kentucky  
Lexington, Kentucky  
Graduated: May 1979

**Employment:**

Feb. 1992 - Present	President Oversee Corporate Officers who manage Estimating, Purchasing, Project Management, Accounting and Risk Management Departments. Directly supervise Corporate Safety Director. Focus on market development and strategic alliances for the long-term success of W. Rogers Company
May 1985 - Feb. 1992	Vice President
Sept. 1979 - May 1985	Project Manager
May 1979 - Sept. 1979	Superintendent
1976 - 1977	Shop Manager
1972 - 1975	Summer Field Worker

**Extra-Curricular Activity**

Graduate - AGC Advanced Management Program, February 1987

President of Kentuckiana Chapter of Associated Builders and Contractors (ABC) - 1991

ABC Board Member 1990 - 1992

KY Associated General Contractors (AGC) - Board Member 2003

Region 6 Trustee of Construction Legal Rights Foundation 1999 to 2002 (Region 6 includes Kentucky, Indiana, Michigan and Ohio)  
ABC Affiliated

Instructor at Mayor's (Lexington) Training Program for Minority and Women's Contracting Firms, 2001 - Present

Elder - Crestwood Christian Church, 1998 to Present

Chairman of Building Committee - Crestwood Christian Church

Member - Board of Trustees and the Executive Committee of the Lexington Theological Seminary

**WILLIAM BOYD ROGERS, JR.**



**W.  
ROGERS  
COMPANY**

**Education:**

Bourbon County High School  
Paris, Kentucky  
Graduated: May 1975

University of Kentucky  
Attended: September 1975 to December 1976  
September 1977 to May 1978  
Major: Business Administration

Lexington Technological Institute  
Attended: September 1978 to May 1979  
Major: Engineering Technology

**Employment:**

W. Rogers Company  
Vice President -February 1992 - Present

**Duties:** Duties: Responsible for procurement of new projects for the Company and directing the Estimating department staff. This includes identifying potential markets, qualifying projects for acceptability and evaluating potential Owners. Oversight of estimating staff during solicitation of projects, including MBE & WBE solicitation. Directly involved in solicitation and estimating of process equipment for all projects.

Responsible for negotiating to reduce cost on acceptable terms and arrangements with Owners and Engineers when projects are over-budget or changes are desired for other reasons.

Cooperate with and assist Project Managers when negotiating change orders on active projects with Owners and Engineers.

Assist Owners and Consulting Engineers with evaluating estimated cost, constructability issues and schedule requirements during design phase.

Oversight responsibility for Company construction equipment operations working with Company Equipment Manager to determine long term and short term equipment needs, equipment acquisitions and liquidations.

Cooperate with other Corporate Officers in determining Company policy, operations and business direction.

W. Rogers Company, 1976 - 1992

Held various positions as follows:

Purchasing Manager - 1983 to January 1992, Buyer - 1982 to 1983,  
Assistant Buyer - 1980-1982, Shop Laborer - 1976 to 1980.

**MICHAEL P. BAILEY**



**Education:**

B.S. , Civil Engineering  
Concentration: Infrastructure Track  
Virginia Polytechnic Institute & State University  
Blacksburg, Virginia

**Skills:**

AutoCAD, Microstation, Total Station, GPS, WinEX Pro (Earth quantity takeoff software), Microsoft Office

**Employment:**

W. Rogers Company  
Project Manager  
2006 to Present

26 MGD Membrane Water Treatment Plant – Clarksville, Tennessee  
Contract Amount: \$25,174,438.00 (Ongoing – Est Completion – 6/13)

Pitman Creek Wastewater Treatment Plant – Somerset, Kentucky  
Contract Amount: \$12,806,972 (Ongoing – Est Completion 4/12)

Deep Springs Pumping Station – Lexington, Kentucky  
Contract Amount: \$1,786,000.00 (Ongoing – Est Completion 4/12)

Turkey Creek Wastewater Treatment Plant - Knoxville, Tennessee  
Contract Amount: \$17,386,480.00

Ohio County Wastewater Treatment Plant - Beaver Dam, Kentucky  
Contract Amount: \$9,172,000.00

North Elkhorn Pump Station - Lexington, Kentucky  
Contract Amount: \$4,006,000.00

Bee Creek Wastewater Treatment Plant - Murray, Kentucky  
Contract Amount: \$1,374,000.00

Project Superintendent  
August 2005 to Present  
Oostanaula Wastewater Treatment Plant - Athens, Tennessee  
Contract Amount: \$15,433,000.00

Project Engineer  
January 2003 to August 2005  
Duties include survey layout (Total Station); provide assistance to Project Superintendents on various sites with supervision of site labor and subcontractor management.



MICHAEL P. BAILEY

---

Page 2

Construction Intern

Summer 2002

Duties included supplemental jobsite engineering and subcontractor monitoring for various projects including Upper Wolf Run Pump Station in Lexington, Kentucky

PDR Engineers - Lexington, Kentucky

Survey Crew

1999 to 2000

Rod man, instrument man, ran level loops for general construction, wastewater and highway surveys.

**1.09 EQUAL OPPORTUNITY AGREEMENT**

**The Law**

- Title VII of the Civil Rights Act of 1964 (amended 1972) states that it is unlawful for an employer to discriminate in employment because of race, color, religion, sex, age (40-70 years) or national origin
- Executive Order No. 11246 on Nondiscrimination under Federal contract prohibits employment discrimination by contractor and subcontractor doing business with the Federal Government or recipients of Federal funds. This order was later amended by Executive Order No. 11375 to prohibit discrimination on the basis of sex.
- Section 503 of the Rehabilitation Act of 1973 States:

*The Contractor will not discriminate against any employee or applicant for employment because of physical or mental handicap.*

- Section 2012 of the Vietnam Era Veterans Readjustment Act of 1973 requires Affirmative Action on behalf of disabled veterans and veterans of the Vietnam Era by contractors having Federal Contracts
- Section 206 (A) of Executive Order 12086, Consolidation of Contract Compliance Functions for Equal Employment Opportunity, states:

*The Secretary of Labor may investigate the employment practices of any Government contractor or sub-contractor to determine whether or not the contractual provisions specified in Section 202 of this order have been violated.*

The Lexington-Fayette Urban County Government practices Equal Opportunity in recruiting, hiring and promoting. It is the Government's intent to affirmatively provide employment opportunities for those individuals who have previously not been allowed to enter into the mainstream of society. Because of its importance to the local Government, this policy carries the full endorsement of the Mayor, Commissioners, Directors, and all supervisory personnel. In following this commitment to Equal Employment Opportunity and because the Government is the benefactor of the Federal funds, it is both against the Urban County Government policy and illegal for the Government to let contracts to companies which knowingly or unknowingly practice discrimination in their employment practices. Violation of the above mentioned ordinances may cause an Agreement to be canceled and the contractor may be declared ineligible for future consideration.

Please sign this statement in the appropriate space acknowledging that you have read and understand the provisions contained herein. Return this document as part of your application packet.

**Bidders**

I/We agree to comply with the Civil Rights Laws listed above that govern employment rights of minorities, women, Vietnam veterans, handicapped, and aged persons.

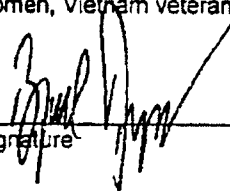
  
\_\_\_\_\_  
Signature

WRC1, LLC dba W. Rogers Company  
\_\_\_\_\_  
Name of Business

The Entity (regardless of whether construction Contractor, non-construction Contractor or supplier) agrees to provide equal opportunity in employment for all qualified persons, to prohibit discrimination in employment because of race, color, creed, national origin, sex or age, and to promote equal employment through a positive, continuing program from itself and each of its sub-contracting agents. This program of equal employment opportunity shall apply to every aspect of its employment policies and practices.

The Kentucky Equal Employment Opportunity Act of 1978 (KRS 45.560-45.640) requires that any county, city, town, school district, water district, hospital district, or other political subdivision of the state shall include in directly or indirectly publicly funded contracts for supplies, materials, services, or equipment hereinafter entered into the following provisions:

During the performance of this contract, the contractor agrees as follows:

- (1) *The contractor will not discriminate against any employee or applicant for employment because of race, color, religion, sex, age or national origin;*
- (2) *The contractor will state in all solicitations or advertisements for employees placed by or on behalf of the contractors that all qualified applicants will receive consideration for employment without regard to race, color, religion, sex, age or national origin;*
- (3) *The contractor will post notices in conspicuous places, available to employees and applicants for employment, setting forth the provisions of the non-discrimination clauses required by this section, and*
- (4) *The contractor will send a notice to each labor union or representative of workers with which he has a collective bargaining agreement or other contract or understanding advising the labor union or workers' representative of the contractor's commitments under the nondiscrimination clauses.*

The Act further provides:

#### KRS 45.610. Hiring minorities - Information required

- (1) *For the length of the contract, each contractor shall hire minorities from other sources within the drawing area, should the union with which he has collective bargaining agreements be unwilling to supply sufficient minorities to satisfy the agreed upon goals and timetable.*
- (2) *Each contractor shall, for the length of the contract, furnish such information as required by KRS 45.560 to KRS 45.640 and by such rules, regulations and orders issued pursuant thereto and will permit access to all books and records pertaining to his employment practices and work sites by the contracting agency and the department for purposes of investigation to ascertain compliance with KRS 45.560 to 45.640 and such rules, regulations and orders issued pursuant thereto.*

#### KRS 45.620. Action against contractor - Hiring of minority contractor or subcontractor

- (1) *If any contractor is found by the department to have engaged in an unlawful practice under this chapter during the course of performing under a contract or subcontract covered under KRS 45.560 to 45.640, the department shall so certify to the contracting agency and such certification shall be binding upon the contracting agency unless it is reversed in the course of judicial review.*
- (2) *If the contractor is found to have committed an unlawful practice under KRS 45.560 to 45.640, the contracting agency may cancel or terminate the contract, conditioned upon a program for future compliance approved by the contracting agency and the department. The contracting agency may declare such a contractor ineligible to bid on further contracts with that agency until such time as the contractor complies in full with the requirements of KRS 45.560 to 45.640.*
- (3) *The equal employment provisions of KRS 45.560 to 45.640 may be met in part by a contractor by subcontracting to a minority contractor or subcontractor. For the provisions of KRS 45.560 to 45.640, a minority contractor or subcontractor shall mean a business that is owned and controlled by one or more persons disadvantaged by racial or ethnic circumstances.*

KRS 45 630 Termination of existing employee not required, when

*Any provision of KRS 45.560 to 45.640 notwithstanding, no contractor shall be required to terminate an existing employee upon proof that that employee was employed prior to the date of the contract.*

KRS 45 640 Minimum skills

*Nothing in KRS 45.560 to 45.640 shall require a contractor to hire anyone who fails to demonstrate the minimum skills required to perform a particular job*

In the case of an Agreement exceeding \$250,000, the Contractor will be required within seven (7) days following the Bid Opening to furnish evidence that its work-force in Kentucky is representative of the available work-force in the area from which it draws employees, or to supply an Affirmative Action plan which will achieve such representation during the life of the Contract

1.10 MWDBE SUBCONTRACTOR PARTICIPATION FORM

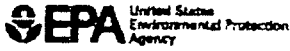

OMB Control No: 2090-0030  
 Approved: 8/13/2013  
 Approval Expires: 8/31/2015

**Disadvantaged Business Enterprise (DBE) Program  
 DBE Subcontractor Participation Form**

An EPA Financial Assistance Agreement Recipient must require its prime contractors to provide this form to its DBE subcontractors. This form gives a DBE<sup>1</sup> subcontractor<sup>2</sup> the opportunity to describe work received and/or report any concerns regarding the EPA-funded project (e.g. in areas such as termination by prime contractor, late payments, etc.). The DBE subcontractor can, as an option, complete and submit this form to the EPA DBE Coordinator at any time during the project period of performance.

Subcontractor Name		Project Name	
Bid/ Proposal No.	Assistance Agreement ID No. (if known)	Point of Contact	
Address			
Telephone No.		Email Address	
Prime Contractor Name		Issuing/Funding Entity:	

Contract Item Number	Description of Work Received from the Prime Contractor Involving Construction, Services, Equipment or Supplies	Amount Received by Prime Contractor

<sup>1</sup> A DBE is a Disadvantaged, Minority, or Woman Business Enterprise that has been certified by an entity from which EPA accepts certifications as described in 40 CFR 33.204-33.205 or certified by EPA. EPA accepts certifications from entities that meet or exceed EPA certification standards as described in 40 CFR 33.202.

<sup>2</sup> Subcontractor is defined as a company, firm, joint venture, or individual who enters into an agreement with a contractor to provide services pursuant to an EPA award of financial assistance.

EPA FORM 6100-2 (DBE Subcontractor Participation Form)

**Disadvantaged Business Enterprise (DBE) Program  
DBE Subcontractor Participation Form**

Please use the space below to report any concerns regarding the above EPA-funded project:

---

---

---

---

---

---

---

---

---

---

---

---

---

---

---

---

<b>Subcontractor Signature</b>	<b>Print Name</b>
<b>Title</b>	<b>Date</b>

The public reporting and recordkeeping burden for this collection of information is estimated to average three (3) hours per response. Send comments on the Agency's need for this information, the accuracy of the provided burden estimates, and any suggested methods for minimizing respondent burden, including through the use of automated collection techniques to the Director, Collection Strategies Division, U.S. Environmental Protection Agency (2822T), 1200 Pennsylvania Ave., NW, Washington, D.C. 20460. Include the OMB control number in any correspondence. Do not send the completed form to this address.

EPA FORM 6100-2 (DBE Subcontractor Participation Form)

1.11 MWDBE SUBCONTRACTOR PERFORMANCE FORM



OMB Control No: 2090-0030  
 Approved: 8/13/2013  
 Approval Expires: 8/31/2015

**Disadvantaged Business Enterprise (DBE) Program  
 DBE Subcontractor Performance Form**

This form is intended to capture the DBE<sup>1</sup> subcontractor's<sup>2</sup> description of work to be performed and the price of the work submitted to the prime contractor. An EPA Financial Assistance Agreement Recipient must require its prime contractor to have its DBE subcontractors complete this form and include all completed forms in the prime contractor's bid or proposal package.

Subcontractor Name		Project Name	
Bid/ Proposal No.	Assistance Agreement ID No. (if known)	Point of Contact	
Address			
Telephone No.		Email Address	
Prime Contractor Name		Issuing/Funding Entity:	

Contract Item Number	Description of Work Submitted to the Prime Contractor Involving Construction, Services, Equipment or Supplies	Price of Work Submitted to the Prime Contractor
DBE Certified By: <input type="checkbox"/> DOT <input type="checkbox"/> SBA		Meets/ exceeds EPA certification standards?
<input type="checkbox"/> Other: _____		<input type="checkbox"/> YES <input type="checkbox"/> NO <input type="checkbox"/> Unknown

<sup>1</sup> A DBE is a Disadvantaged, Minority, or Woman Business Enterprise that has been certified by an entity from which EPA accepts certifications as described in 40 CFR 33.204-33.205 or certified by EPA. EPA accepts certifications from entities that meet or exceed EPA certification standards as described in 40 CFR 33.202.

<sup>2</sup> Subcontractor is defined as a company, firm, joint venture, or individual who enters into an agreement with a contractor to provide services pursuant to an EPA award of financial assistance.

EPA FORM 6100-3 (DBE Subcontractor Performance Form)

**Disadvantaged Business Enterprise (DBE) Program  
 DBE Subcontractor Performance Form**

I certify under penalty of perjury that the forgoing statements are true and correct. Signing this form does not signify a commitment to utilize the subcontractors above. I am aware of that in the event of a replacement of a subcontractor, I will adhere to the replacement requirements set forth in 40 CFR Part 33 Section 33.302 (c).

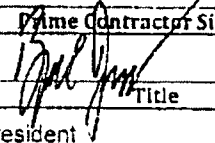
<b>Prime Contractor Signature</b>	<b>Print Name</b>
	Boyd Rogers
<b>Title</b>	<b>Date</b>
Vice President	09/26/2017

<b>Subcontractor Signature</b>	<b>Print Name</b>
<b>Title</b>	<b>Date</b>

The public reporting and recordkeeping burden for this collection of information is estimated to average three (3) hours per response. Send comments on the Agency's need for this information, the accuracy of the provided burden estimates, and any suggested methods for minimizing respondent burden, including through the use of automated collection techniques to the Director, Collection Strategies Division, U.S. Environmental Protection Agency (2822T), 1200 Pennsylvania Ave., NW, Washington, D.C. 20460. Include the OMB control number in any correspondence. Do not send the completed form to this address.

EPA FORM 6100-3 (DBE Subcontractor Performance Form)



1.12 MWDBE SUBCONTRACTOR UTILIZATION FORM



OMB Control No: 2090-0030  
 Approved: 8/13/2013  
 Approval Expires: 8/31/2015

Disadvantaged Business Enterprise (DBE) Program  
 DBE Subcontractor Utilization Form

This form is intended to capture the prime contractor's actual and/or anticipated use of identified certified DBE<sup>1</sup> subcontractors<sup>2</sup> and the estimated dollar amount of each subcontract. An EPA Financial Assistance Agreement Recipient must require its prime contractors to complete this form and include it in the bid or proposal package. Prime contractors should also maintain a copy of this form on file.

Prime Contractor Name WRC1, LLC dba W. Rogers Company		Project Name Expansion Area 3 Pump Station Improvements (Contract No. 1)	
Bid/ Proposal No. 160-2017	Assistance Agreement ID No. (if known)	Point of Contact Boyd Rogers	
Address 649 Bizzell Drive, Lexington KY 40510			
Telephone No. 859-231-6290		Email Address boydr@wrogers.com	
Issuing/Funding Entity:			

I have identified potential DBE certified subcontractors	___ YES	___ NO	
If yes, please complete the table below. If no, please explain			
Subcontractor Name/ Company Name	Company Address/ Phone/ Email	Est. Dollar Amt	Currently DBE Certified?

Continue on back if needed

<sup>1</sup> A DBE is a Disadvantaged, Minority, or Woman Business Enterprise that has been certified by an entity from which EPA accepts certifications as described in 40 CFR 33.204-33.205 or certified by EPA. EPA accepts certifications from entities that meet or exceed EPA certification standards as described in 40 CFR 33.202.

<sup>2</sup> Subcontractor is defined as a company, firm, joint venture, or individual who enters into an agreement with a contractor to provide services pursuant to an EPA award of financial assistance.

EPA FORM 6100-4 (DBE Subcontractor Utilization Form)

**Disadvantaged Business Enterprise (DBE) Program  
DBE Subcontractor Utilization Form**

I certify under penalty of perjury that the forgoing statements are true and correct. Signing this form does not signify a commitment to utilize the subcontractors above. I am aware of that in the event of a replacement of a subcontractor, I will adhere to the replacement requirements set forth in 40 CFR Part 33 Section 33.302 (c).

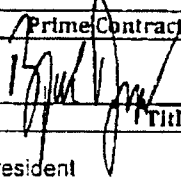
	<b>Prime Contractor Signature</b>	<b>Print Name</b>
		Boyd Rogers
<b>Title</b>		<b>Date</b>
Vice President		09/26/2017

The public reporting and recordkeeping burden for this collection of information is estimated to average three (3) hours per response. Send comments on the Agency's need for this information, the accuracy of the provided burden estimates, and any suggested methods for minimizing respondent burden, including through the use of automated collection techniques to the Director, Collection Strategies Division, U.S. Environmental Protection Agency (2822T), 1200 Pennsylvania Ave., NW, Washington, D.C. 20460. Include the OMB control number in any correspondence. Do not send the completed form to this address.

EPA FORM 6100-4 (DBE Subcontractor Utilization Form)

1.13 MWDBE PARTICIPATION POLICY

PROJECT NAME: EA3 Pump Station & Force Main - Lexington-Fayette Urban County Government No. 1)

LFUCG BID NO. 60-2617 BID DATE: 08/25/2017

A. Name, address and telephone number of contact person on all MWDBE matters:

Prime Contractor's Name WRC1, LLC dba W. Rogers Company  
Contact Person: Boyd Rogers  
Address: 649 Bizzell Drive, Lexington KY 40510  
Phone: 859-231-6290 Cell: \_\_\_\_\_  
Email: boydr@wrogers.com  
Total Contract Amount: To Be Determined by Owner

B. Total dollar amount/percent of contract of DBE participation: \_\_\_\_\_

C. Total dollar amount/percent of contract of MBE participation: \_\_\_\_\_

D. Total dollar amount/percent of contract of WBE participation: \_\_\_\_\_

E. Are certifications\* for each MWDBE subcontractor enclosed; if no, please explain:

Yes  No \_\_\_\_\_

F. Are MWDBE subcontracts or letters of intent signed by both parties enclosed; if no, please explain:  Yes  No \_\_\_\_\_

G. List of DBE Subcontractors:

Name \_\_\_\_\_  
Contact Person: \_\_\_\_\_  
Address: \_\_\_\_\_  
Phone: \_\_\_\_\_ Cell: \_\_\_\_\_  
Email: \_\_\_\_\_  
Type of Contract: \_\_\_\_\_  
Work to be Done: \_\_\_\_\_  
Amount: \_\_\_\_\_

H. List of MBE Subcontractors:

Name \_\_\_\_\_  
Contact Person: \_\_\_\_\_  
Address: \_\_\_\_\_  
Phone: \_\_\_\_\_ Cell: \_\_\_\_\_  
Email: \_\_\_\_\_  
Type of Contract: \_\_\_\_\_  
Work to be Done: \_\_\_\_\_  
Amount: \_\_\_\_\_

I. List of WBE Subcontractors:

Name \_\_\_\_\_  
 Contact Person: \_\_\_\_\_  
 Address: \_\_\_\_\_  
 Phone: \_\_\_\_\_ Cell: \_\_\_\_\_  
 Email: \_\_\_\_\_  
 Type of Contract: \_\_\_\_\_  
 Work to be Done: \_\_\_\_\_  
 Amount: \_\_\_\_\_

Attach additional sheets, if necessary.

\*Self-certification: Self-certification of MWDBE firms will NOT be accepted as a valid form of certification of MWDBE status.

**J. Information and documentation concerning efforts taken to comply with EPA's "six good faith efforts"**

1. Ensure MWDBE construction firms or material suppliers are made aware of contracting opportunities to the fullest extent practicable through outreach and recruitment activities; including placing MWDBEs on solicitation lists and soliciting them whenever they are potential sources. A good source for a list of MWDBEs is the Kentucky Transportation's website: <http://transportation.ky.gov/Civil-Rights-and-Small-Business-Development/Pages/Certified-DBE-Directory.aspx>.

The prime contractor certifies that a bidders list (see example sheet below) of qualified vendors, including MWDBEs, was developed for current and future solicitations and that the list will be maintained. *Submit a copy of the list as documentation.*

2. Make information on forthcoming opportunities available to MWDBEs and arrange time frames for contracts and establish delivery schedules, where the requirements permit, in a way that encourages and facilitates participation by MWDBEs in the competitive process; including, whenever possible, posting solicitation for bids or proposals for a sufficient amount of time as to receive a competitive bid or proposal pool.

The prime contractor certifies that every opportunity was provided to a number of MWDBEs to encourage their participation in the competitive process and that an adequate amount of time was provided for response.

- a. List each MWDBE construction firm or material supplier to which a solicitation was attempted. *Submit copies of letters, emails, faxes, telecommunication logs, certified mail receipts, returned envelopes, certified mail return receipts, etc. as documentation.*

Company Name and Phone Number: See Attached  
 Area of Work Expertise: \_\_\_\_\_  
 Date of any Follow-Ups and Person Spoke to: \_\_\_\_\_

- b. Advertisements, if applicable: List each publication in which an announcement or notification was placed. *Submit a tear sheet of each announcement from each publication as documentation.*

Name of Publication: See Attached  
 Date(s) of Advertisement: \_\_\_\_\_  
 Specific Subcontract Areas Announced: \_\_\_\_\_

- c. Other, if applicable: List each notification method in which an announcement or outreach was used; list serve, public meeting, etc. *Submit applicable information to document effort.*

Method of Notification: See Attached

Date(s) of Notification: \_\_\_\_\_

3. Consider in the contracting process whether firms competing for large contracts could subcontract with MWDBEs; including dividing total requirements, when economically feasible, into smaller tasks or quantities to permit maximum participation by MWDBEs in the competitive process.

The prime contractor certifies that the project was broken into its basic elements (i.e. dirt hauling, landscaping, painting, pipe installation, material supplies, etc.) and that a determination was made whether it's economically feasible to bid the elements separately and that the analysis of this effort was documented with a short memo to the project file

4. Establishing delivery schedules, where the requirement permits, which encourage participation by small and minority business, and women's business enterprises.

The prime contractor certifies that they established delivery schedules which would allow MWDBEs to participate in the projects.

5. Use the services and assistance of the Small Business Administration (SBA) and the Minority Business Development Agency (MBDA) of the U.S. Department of Commerce. The easiest way to utilize the services of SBA and MBDA is to visit their websites: [www.sba.gov](http://www.sba.gov) and [www.mbda.gov](http://www.mbda.gov) and use the electronic tools available there or you may send the nearest SBA and MBDA office a certified letter that generally describes the solicitation, the dates it will be open, the types of vendors you are seeking and applicable SIC or NAIC codes if known. You may also use the services and assistance of the Kentucky Procurement Assistance Program (KPAP). The easiest way to utilize the services of KPAP is to send an email: [ced.kpap@ky.gov](mailto:ced.kpap@ky.gov) and provide information on forthcoming opportunities available to MWDBEs.

The prime contractor certifies that the assistance of the SBA, MBDA, and/or KPAP was utilized. *Submit pages printed off the SBA and MBDA websites which evidence efforts to register a solicitation on those sites or submit copies of the letter send and certified mail receipt as documentation; submit copies of emails with KPAP as documentation.*

6. If a subcontractor awards any subcontracts, require the subcontractor to take the steps in numbers 1 and 5 above.

The prime contractor certifies that subcontractors used for this project will be required to follow the steps of the "six good faith efforts" as listed above

**Signature and Date:**

To the best of my knowledge and belief, all "six good faith efforts" have been met and the information contained in this document is true and correct; the document has been duly authorized by the legal representative

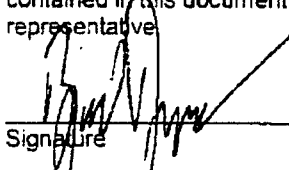
  
\_\_\_\_\_  
Signature

09/26/2017  
\_\_\_\_\_  
Date

Date

Boyd Rogers, Vice President  
\_\_\_\_\_  
Print Name and Title

Print Name and Title

**1.14 EQUAL EMPLOYMENT OPPORTUNITY AFFIRMATIVE ACTION POLICY**

It is the policy of WRC1, LLC dba W. Rogers Company

(Name of Bidder)

to assure that all applicants for employment and all employees are treated on a fair and equitable basis without regard to their race, religion, sex, color, handicap, natural origin or age.

Such action shall include employment, promotion, demotion, recruitment or recruitment advertising, layoff or termination, rates of pay and other forms of compensation, and selection for training, whether apprenticeship and/or on-the-job-training.

Furthermore, this company agrees to make special recruitment efforts to hire the protected class whenever feasible. This company also agrees to adhere to all applicable federal, state, and local laws relating to Equal Employment Opportunity for all individuals.

1.15 WORKFORCE ANALYSIS FORM

Name of Organization: WRC1, LLC dba W. Rogers Company

Categories	Total		White (not Hispanic or Latino)		Hispanic or Latino		Black or African-American (not Hispanic or Latino)		Native Hawaiian and other Pacific Islander (not Hispanic or Latino)		Asian (not Hispanic or Latino)		American Indian or Alaska Native (not Hispanic or Latino)		Two or more races (not Hispanic or Latino)		Total		
	M	F	M	F	M	F	M	F	M	F	M	F	M	F	M	F	M	F	
Administrators	6																		
Professionals																			
Superintendents	3																		
Supervisors																			
Foremen	2																		
Technicians																			
Protective Service																			
Para-Professionals																			
Office/Clerical	4			4															
Skilled Craft	22			22															
Service/Maintenance	2			2															
Total	39			36															4

Prepared By: Trina Estes, HR/Payroll Date: 09 / 26 / 17

1.16 EVIDENCE OF INSURABILITY

LEXINGTON-FAYETTE URBAN COUNTY GOVERNMENT CONSTRUCTION PROJECT  
 (Use separate form for each Agency or Brokerage agreeing to provide coverage)

Names Insured: \_\_\_\_\_ To Be Forwarded \_\_\_\_\_  
 Address: \_\_\_\_\_  
 Project to be insured: \_\_\_\_\_

In lieu of obtaining certificates of insurance at this time, the undersigned agrees to provide the above Named Insured with the minimum coverage listed below. These are outlined in the Insurance and Risk Management of Section 00600 - Bonds and Certifications, including all requirements, and conditions:

Article Items	Coverage	Minimum Limits and Policy Requirements	Limits Provided to Insured	Name of Insurer	A.M. Best's	
					Code	Rating
1.05.D.1	CGL	\$1,000,000/per occ., \$2,000,000/aggregate or \$2,000,000 combined single limit Requirements (a) through (e)				
1.05.D.1	Auto	Combined single \$1,000,000/per occ. aggregate Requirements (a) through (c)				
1.05.D.1	WC	\$ _____ Statutory				
1.05.D.1	Employer's Liability	\$500,000				

Section 00600 includes required provisions, statements regarding insurance requirements, and the undersigned agrees to abide by all provisions for the coverage's checked above unless stated otherwise when submitting

Agency or Brokerage \_\_\_\_\_ Name of Authorized Representative \_\_\_\_\_  
 Street Address \_\_\_\_\_ Title \_\_\_\_\_  
 City \_\_\_\_\_ Authorized Signature \_\_\_\_\_  
 Telephone Number \_\_\_\_\_ Date \_\_\_\_\_

NOTE: Authorized signatures may be the agent's if agent has placed insurance through an agency agreement with the insurer. If insurance is brokered, authorized signature must be that of authorized representative of insurer.

**IMPORTANT: CONTRACT MAY NOT BE AWARDED IF A COMPLETED AND SIGNED COPY OF THIS FORM FOR ALL COVERAGES LISTED ABOVE IS NOT PROVIDED.**



1.17 DEBARRED FIRMS

PROJECT NAME: Expansion Area 3 Pump Station Improvements (Contract No. 1)

LFUCG BID NO.: 160-2017

LEXINGTON-FAYETTE URBAN COUNTY GOVERNMENT  
LEXINGTON, KY

All prime Contractors shall certify that Subcontractors have not and will not be awarded to any firms that has been debarred for noncompliance with the Federal Labor Standards, Title VI of the Civil Rights Act of 1964 As Amended, Executive Order 11246 As Amended or any other Federal Law.

All Bidders shall complete the Debarment Certification in duplicate and submit both copies to the Owner with the Bid Form. The Owner (grantee) shall transmit one copy to the Lexington-Fayette Urban County Government, Division of Community Development within fourteen (14) days after Bid opening.

The undersigned hereby certifies that the firm of WRC1 LLC dba W. Rogers Company has not and will not award a subcontract, in connection with any Agreement award to it as the result of this bid, to any firm that has been debarred for noncompliance with the Federal Labor Standards, Title VI of the Civil Rights Act of 1964, Executive Order 11246 As Amended or any Federal Law.

WRC1 LLC dba W. Rogers Company  
Name of Firm Submitting Bid

  
Signature of Authorized Official

Vice President  
Title

09/26/2017  
Date

**1.18 DEBARMENT CERTIFICATION**

All Contractors/Subcontractors shall complete this certification

The Contractor/Subcontractor certifies in accordance with Executive Order 12549 (Debarment and Suspension 2/18/86) that to the best of its knowledge and belief, that it and its principals:

- 1) Are not presently debarred, suspended, proposed for debarment, declared negligible, or voluntarily excluded from covered transactions or contract by any Federal department or agency for noncompliance with the Federal Labor Standards, Title VI of the Civil Rights Act of 1964 As Amended, Executive Order 11246 As Amended or any other Federal Law.
  - a) Have not within a three year period preceding this Bid been convicted of or had a civil judgment rendered against them for commission of fraud or a criminal offense in connection with obtaining, attempting to obtain, or performing a public (Federal, State or local) transaction or contract under a public transaction; violation of Federal or State antitrust statutes or commission of embezzlement, theft, forgery, bribery, falsification or destruction of records, making false statements or receiving stolen property;
  - b) Are not presently indicted for or otherwise criminally or civilly charged by a government entity (Federal, State or local) with commission of any of the offenses enumerated in paragraph (1)(a) of this certification; and
  - c. Have not within a three (3) year period preceding this Bid has one or more public (Federal, State or local) transactions or contracts terminated for cause or default.
- 2) Where the Contractor is unable to certify to any of the statements in this certification, such prospective contractors shall attach an explanation to this certification form.

Firm Name: WRC1, LLC dba W. Rogers Company

Project: Expansion Area 3 Pump Station Improvements (Contract No. 1)

Printed Name: Boyd Rogers

Title of Authorized Representative: Vice President

Signature: 

Date: 09/26/2017

1.19 CERTIFICATION REGARDING LOBBYING

Certification for Contracts, Grants, Loans, and Cooperative Agreements

The undersigned certifies, to the best of his or her knowledge and belief, that:

- (1) No Federal appropriated funds have been paid or will be paid, by or on behalf of the undersigned, to any person for influencing or attempting to influence an officer or employee of an agency, a Member of Congress, an officer or employee of Congress, or an employee of a Member of Congress in connection with the awarding of any Federal contract, the making of any Federal grant, the making of any Federal loan, the entering into of any cooperative agreement, and the extension, continuation, renewal, amendment, or modification of any Federal contract, grant, loan, or cooperative agreement.
- (2) If any funds other than Federal appropriated funds have been paid or will be paid to any person for influencing or attempting to influence an officer or employee of any agency, a Member of Congress, an officer or employee of Congress, or an employee of a Member of Congress in connection with this Federal contract, grant, loan, or cooperative agreement, the undersigned shall complete and submit Standard Form-LLL, "Disclosure Form to Report Lobbying," in accordance with its instructions.
- (3) The undersigned shall require that the language of this certification be included in the award documents for all sub-awards at all tiers (including subcontracts, sub-grants, and contracts under grants, loans, and cooperative agreements) and that all sub-recipients shall certify and disclose accordingly.

This certification is a material representation of fact upon which reliance was placed when this transaction was made or entered into. Submission of this certification is a prerequisite for making or entering into this transaction imposed by Section 1352, Title 31, U.S. Code. Any person who fails to file the required certification shall be subject to a civil penalty for not less than \$10,000 and not more than \$100,000 for each such failure.

Boyd Rogers, Vice President  
\_\_\_\_\_  
Typed Name & Title of Authorized Representative

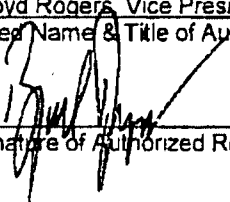
  
\_\_\_\_\_  
Signature of Authorized Representative

09/26/2017  
\_\_\_\_\_  
Date

\_\_\_\_ I am unable to certify to the above statements. My explanation is attached.

1.20 BID BOND

BID BOND

Bond Number: N/A

KNOW ALL MEN BY THESE PRESENTS, that we WRC 1, LLC  
as principal (the "Principal") and TRAVELERS CASUALTY AND SURETY COMPANY OF AMERICA  
hereinto called Surety, are held and firmly bound unto

LEXINGTON-FAYETTE URBAN COUNTY GOVERNMENT  
200 East Main Street, Third Floor  
Lexington, Kentucky 40507

as obligee (the "Obligee"), in the penal sum of FIVE PERCENT OF TOTAL BID dollars  
for the payment of which sum well and truly to be made, the said Principal and the said Surety, bind  
ourselves, our heirs, executors, administrators, successors and assigns, jointly and severally, firmly by  
these presents.

WHEREAS, the Principal has submitted a bid for  
EXPANSION AREA 3 PUMP STATION (CONTRACT 1)

NOW, THEREFORE, if the Obligee shall accept the bid of the Principal within the period specified therein,  
or, if no period be specified, within ninety (90) days after opening, and the Principal shall enter into a  
contract with the Obligee in accordance with the terms of such bid, and give such bond or bonds as may  
be specified in the bidding or contract documents, or in the event of the failure of the Principal to enter into  
such contract and give such bond or bonds, if the Principal shall pay to the Obligee the difference in  
money not to exceed the penal sum hereof between the amount specified in said bid and such larger  
amount for which the Obligee may in good faith contract with another party to perform the work covered by  
said bid, then this obligation shall be null and void; otherwise to remain in full force and effect. In no event  
shall the liability hereunder exceed the penal sum thereof.

PROVIDED AND SUBJECT TO THE CONDITION PRECEDENT, that any claim by Obligee under this  
bond must be submitted in writing by registered mail, to the attention of the Surety Law Department at the  
address above, within 120 days of the date of this bond. Any suit under this bond must be instituted before  
the expiration of one (1) year from the date of this bond. If the provisions of this paragraph are void or  
prohibited by law, the minimum period of limitation available to sureties as a defense in the jurisdiction of  
the suit shall apply.

DATED as of this 26TH day of SEPTEMBER, 20 17.

WITNESS / ATTEST:

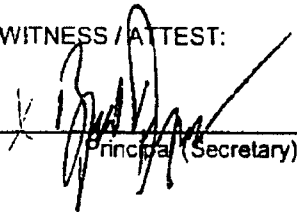
  
Principal (Secretary)

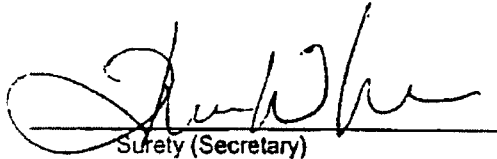
  
Surety (Secretary)

WRC 1, LLC  
Principal

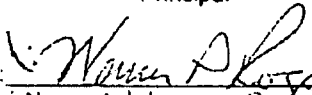
By:  (seal)  
Name: Warren Rogers  
Title: President

TRAVELERS CASUALTY AND SURETY  
COMPANY OF AMERICA  
Surety

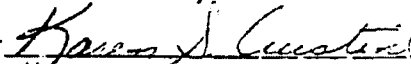
By:  (seal)  
Name: KAREN S. AUSTIN  
Title: ATTORNEY-IN-FACT AND  
RESIDENT KENTUCKY AGENT

**TRAVELERS**

**POWER OF ATTORNEY**

Farmington Casualty Company  
Fidelity and Guaranty Insurance Company  
Fidelity and Guaranty Insurance Underwriters, Inc.  
St. Paul Fire and Marine Insurance Company  
St. Paul Guardian Insurance Company

St. Paul Mercury Insurance Company  
Travelers Casualty and Surety Company  
Travelers Casualty and Surety Company of America  
United States Fidelity and Guaranty Company

Attorney-In Fact No. 217872

Certificate No. 006290075

KNOW ALL MEN BY THESE PRESENTS That Farmington Casualty Company, St. Paul Fire and Marine Insurance Company, St. Paul Guardian Insurance Company, St. Paul Mercury Insurance Company, Travelers Casualty and Surety Company, Travelers Casualty and Surety Company of America, and United States Fidelity and Guaranty Company are corporations duly organized under the laws of the State of Connecticut, that Fidelity and Guaranty Insurance Company is a corporation duly organized under the laws of the State of Iowa, and that Fidelity and Guaranty Insurance Underwriters, Inc. is a corporation duly organized under the laws of the State of Wisconsin (herein collectively called the "Companies"), and that the Companies do hereby make, constitute and appoint

Karen S. Austin, and Linda L. Hogle

of the City of Fort Thomas, State of Kentucky, their true and lawful Attorney(s)-in-Fact, each in their separate capacity if more than one is named above, to sign, execute, seal and acknowledge any and all bonds, recognizances, conditional undertakings and other writings obligatory in the nature thereof on behalf of the Companies in their business of guaranteeing the fidelity of persons, guaranteeing the performance of contracts and executing or guaranteeing bonds and undertakings required or permitted in any actions or proceedings allowed by law.

IN WITNESS WHEREOF, the Companies have caused this instrument to be signed and their corporate seals to be hereto affixed, this 27th day of July, 2015

Farmington Casualty Company  
Fidelity and Guaranty Insurance Company  
Fidelity and Guaranty Insurance Underwriters, Inc.  
St. Paul Fire and Marine Insurance Company  
St. Paul Guardian Insurance Company

St. Paul Mercury Insurance Company  
Travelers Casualty and Surety Company  
Travelers Casualty and Surety Company of America  
United States Fidelity and Guaranty Company



State of Connecticut  
City of Hartford ss.

By: Robert L. Raney  
Robert L. Raney, Senior Vice President

On this the 27th day of July, 2015, before me personally appeared Robert L. Raney, who acknowledged himself to be the Senior Vice President of Farmington Casualty Company, Fidelity and Guaranty Insurance Company, Fidelity and Guaranty Insurance Underwriters, Inc., St. Paul Fire and Marine Insurance Company, St. Paul Guardian Insurance Company, St. Paul Mercury Insurance Company, Travelers Casualty and Surety Company, Travelers Casualty and Surety Company of America, and United States Fidelity and Guaranty Company, and that he, as such, being authorized so to do, executed the foregoing instrument for the purposes therein contained by signing on behalf of the corporations by himself as a duly authorized officer.

In Witness Whereof, I hereunto set my hand and official seal  
My Commission expires the 30th day of June, 2016.



Marie C. Tetreault  
Marie C. Tetreault, Notary Public

EA3 Pump Station (Contract No. 1) Equipment Manufacturer (circle one) - Bid Basis	
Solids Handling Submersible Pumps	ABS Flygt <u>KSB</u>
Mechanical Bar Screens	Headworks <u>Huber Technology</u> Duperon
Screenings Compactors	Headworks <u>Huber Technology</u> Duperon
Screening Conveyors	Headworks <u>Huber Technology</u> Duperon
Sump Pumps	Myers <u>Flygt</u> Hydromatic Zoeller
Odor Control Absorber	<u>ECS Environmental Solutions/Calgon</u> Daniel Company Pure Air Filtration
Odor Control Chemical Feed System	<u>Evoqua</u>
Check Valves	<u>Apco</u> Golden Anderson Val-matic
Modulating Plug Valve	<u>Dezurik</u> Golden Anderson Henry Pratt
Slide/Sluice Gates	<u>Aquanox</u> Waterman Golden Harvest
Electric Actuators	Limitorque <u>Auma</u> EIM
Generator	Generac Caterpillar <del>Cummins/ONAN</del> MTU/Detroit Diesel <u>Kohler</u>
Level Transmitters	<u>Endress+Hauser</u> Foxboro Siemens Yokogawa
VFDs	Square D <u>Eaton</u> Allen Bradley
SCADA PLC's	<u>Allen Bradley Compactlogix</u>
Motor Control Centers	Square D <u>Cutler Hammer</u> Allen Bradley

# MWDBE Documentation

W Rogers Company

LFUCG Expansion Area 3 Pump Station – Lexington KY

## Index:

- 1: Solicitation List
- 2: Original Solicitation and Advertisements
- 3: Responsive Bidders & Correspondence
- 4: Quotes Received with EPA Forms





Address	City	State	Zip	Phone	Phone Ext	Fax	Fax Ext	Commodity	Special Classifications	First Name	Last Name	Email
10000 Sycamore Dr	Dayton	OH	45407	9374353700		9377916549		Water and Wastewater T SBE, MBE		Robert	O'Grady	rose.ogrady@nteng.com
10000 Sycamore Dr	Huntsville	AL	35806	2564903566				Water and Wastewater T		Robert	Grab	rgrob@idexcorp.com
10000 Sycamore Dr	Louisville	KY	40210	5027755741		5027755741		Water and Wastewater T SBE, MBE, DBE		Rick	Strom	strom@bryant-engis.com
10000 Sycamore Dr	LEXINGTON	KY	40504	8592784280		8594023396		Water and Wastewater T SBE, WBE, DBE		BRENDAH	TIGHE	Brendan.tighe2@gmail.com
10000 Sycamore Dr	Winchester	KY	40391	8598934640				Water and Wastewater T		Zachary	Stanfield	zakthelstair@gmail.com
10000 Sycamore Dr	Georgetown	KY	40324	5025705252				Water and Wastewater T SBE		Woody	Deets	wdeets@bluegrassstrucks.com
10000 Sycamore Dr	Georgetown	KY	40324	5025705252				Water and Wastewater T SBE		Doug	Jones	djones@bluegrassstrucks.com
10000 Sycamore Dr	Prospect	KY	40059	50217413005				Water and Wastewater T SBE		Theresa	Bakcom	tbakcom@brwmlifeidemy.com
10000 Sycamore Dr	Peru	IL	61354	8004356856	6503	8152246497		Water and Wastewater T SBE		Samantha	Pumo	bp@et-chemicals.com
10000 Sycamore Dr	Richmond	KY	40475	8596216751				Water and Wastewater T SBE, SDOVSB		Bob	Suffel	bob@suffel.com
10000 Sycamore Dr	Nathville	TN	37210	6152327040		6152327005		Water and Wastewater T SBE, MBE, WBE, DBE		Turner	Turner	turner@edvermaproducts.com
10000 Sycamore Dr	London	KY	40314	8665826895		8778012523		Water and Wastewater T SBE, WBE, HUD		Michael	Jones	east@corporation@gmail.com
10000 Sycamore Dr	North Charleston	SC	29420	84367071677				Water and Wastewater T SBE, MBE, DBE, VOSB		Clifford	Smith	smith@eccocap.com
10000 Sycamore Dr	Louisville	KY	40202	5029923194				Water and Wastewater T SBE, VOSB		Ryan	Holmes	rholmes@eticonsultants.com
10000 Sycamore Dr	Greedy	CD	80634	9703463959		9703463959		Water and Wastewater T SBE		Jerry	Xonist	jonist@emviretechservices.com
10000 Sycamore Dr	Atlanta	GA	30338	3238039471	231	8683153950		Water and Wastewater T SBE		David	Taylor	David.Taylor@epochchemicals.com
10000 Sycamore Dr	Montreal	QC	H1P 3A8	5143268953				Water and Wastewater T SBE		John	Maicelli	johnm@etinc.com
10000 Sycamore Dr	Shelbyville	KY	40065	5026333939		5026333939		Water and Wastewater T SBE		Kris	Smith	kimbo@evgreenaas.com
10000 Sycamore Dr	Lexington	KY	40504	8592552236		8592552236		Water and Wastewater T SBE		Kim	Gabbard	kimbo@evgreenaas.com
10000 Sycamore Dr	Noblesville	IN	46060	853739776		853739776		Water and Wastewater T SBE		Connie	Miller	nancy@groups.com
10000 Sycamore Dr	Lexington	KY	40507	8591518666		8591518666		Water and Wastewater T SBE, MBE, WBE		Dan	Gullett	dangullett@fuse.net
10000 Sycamore Dr	Bethel	OH	45106	5137342227		5137342227		Water and Wastewater T SBE		Charles	happy	charid.happy42@gmail.com
10000 Sycamore Dr	Richmond	KY	40475	8595091679		8595091679		Water and Wastewater T SBE		Joe	Harvey	joeh@hody.com
10000 Sycamore Dr	Lexington	KY	40511	5192803278		6196775648		Water and Wastewater T SBE, SDOVSB		Joe	Davis	JTDavis@Gmail.com
10000 Sycamore Dr	Lexington	KY	40507	3176856610		3176856610		Water and Wastewater T SBE, MBE, DBE		Michael	Davis	mdavis@leiremids.com
10000 Sycamore Dr	Indianapolis	IN	46202	3176856600		4407298138		Water and Wastewater T SBE, MBE, DBE		Julie	Keinick	jll@JACOnline.com
10000 Sycamore Dr	Chesapeake	VA	44026	4407298138				Water and Wastewater T SBE, WBE		Lisa	Peasley	leung@leiremids.com
10000 Sycamore Dr	Hillsboro	OH	45133	9379311779				Water and Wastewater T SBE, WBE		Allen	Leininger	leung@leiremids.com
10000 Sycamore Dr	Lexington	KY	40507	8592816581				Water and Wastewater T SBE, WBE		Heather	Lyons	hlyons@taskca.org
10000 Sycamore Dr	Lexington	KY	40508	8592552222				Water and Wastewater T SBE		Scott	Wilson	swilson@ps-ky.com
10000 Sycamore Dr	Lexington	KY	40524	5028682240		5028682247		Water and Wastewater T SBE		Conne	Allen	connie@ssahireng.com
10000 Sycamore Dr	Harrodsburg	KY	40330	8593211911				Water and Wastewater T SBE, WBE, VOSB		Danette	Wilder	wilder@jglicontracting.com
10000 Sycamore Dr	Lexington	KY	40504	8599776640		8599776644		Water and Wastewater T SBE, MBE, WBE, DBE		Karen	Thompson	karen@smultmanage.com
10000 Sycamore Dr	Lexington	KY	40511	859218936		859218997		Water and Wastewater T SBE, WBE		Tom	Goodby	tomgoodby@stalandre.com
10000 Sycamore Dr	Houston	TX	77092	7136600482		7136600197		Water and Wastewater T SBE, MBE, VOSB		Mark	Dodds	mark@stingfellow.biz
10000 Sycamore Dr	Nashville	TN	37203	6152764900		5022903840		Water and Wastewater T SBE		Ben	Turnip	biurpin@englonky.gov
10000 Sycamore Dr	Richmond	KY	40503	8954152232				Water and Wastewater T SBE, DBE		Shelia	Waldor	shelia@uscubed.com
10000 Sycamore Dr	Santa Ana	CA	92705	7145843494				Water and Wastewater T SBE, MBE, DBE		Sally	Waldor	sallywalbor@wtrivales.com
10000 Sycamore Dr	Bloomington	MN	55420	9524439004				Water and Wastewater T SBE, WBE		Teri	Collins	teri.collins@washsupply.com
10000 Sycamore Dr	Evanville	IN	47725	8004301417	101	3706414817		Water and Wastewater T SBE, MBE, DBE, HUD		Marnin	Young	mnyoung@mpykd.com
10000 Sycamore Dr	Lexington	KY	40509	5026032045		8593094197		Water and Wastewater T SBE, MBE, DBE, HUD				

Company	Address 1	City	State	Zip	Contact	Title	Phone	Fax	Email
Lestlar Mineral Development Inc.	1108 Versailles Rd #508	Lexington	KY	40508	Lestlar Boyd	President	Phone 859-608-9826	Fax 859-253-1030	lestlar@unpcc.com
G & C PAVING AND CONSTRUCTION INC	3136 BRACKTOWN RD	Lexington	KY	40511	MARVIN	PRESIDENT	Phone 859-255-6029	Fax 859-233-2365	gcpaving@inslabbb.com
Leaungon Contracting LLC	1500 Leeslow Rd	Lexington	KY	40511	Allen Carter	President	Phone 859-281-8881	Fax 859-281-8850	AGLECONTRACTING@AOL.COM
Sallie's Wholesale & Construction, Inc.	1188 Dresden Drive	Manfield	OH	44805	Sallie J. Strywiler	Owner/CEO	Phone 419-524-7873	Fax 419-524-7874	sallie_j@salliewholesale.com
TAS Development LLC	1450 North Broadway	Lexington	KY	40505	Ernest Smith	CEO	Phone 859-433-7181	Fax 859-231-0178	ernst@tasdevelopment.com
Thoroughbred Mowing & Ag Services	871 Burgess Smith Rd	Sadieville	KY	40370	Levi Courtney	registered agent	Phone 502-370-5635	Fax 502-857-2028	lrcourt@thoroughbred.com
Tricon Services Inc	8182 Duke Blvd	Mason	OH	45040	Richard Schock	Vice President of Sales & Marketing	Phone 513-879-8800	Fax 513-879-6807	rschock@triconcontracting.com
River City Controls, Inc	753 Tracy Lynn Lane	Lebanon Junction	KY	40150	Lisa Bailey	President	Phone 502-543-4007	Fax 502-543-2867	lrb@rivercitycontrols.com
SJ Earth Boring	P O Box 29	Shelby	KY	40372	Shelia Jo Burke	Owner/CEO	Phone 859-865-2083		shburke@sjearth.com
Affordable Building Supplies, LLC	55 South State Ave., Suite 201	Indianapolis	IN	46201	Keith Payne	Managing Member	Phone 317-836-0445		info@affordablebuilding.com
C.A. Fulkerson, LLC	P O Box 336	Lanesville	IN	47136	Carol Fulkerson	President	Phone 812-852-1777	Fax 812-852-1770	cafulkerson@afg.com
Cedar Valley Seeding	851 Redmon Road	Pars	KY	40361	Susan Redmon	President	Phone 859-967-1497		csredmon@cedarvalley.com
Tom Levy & Associates, Inc	1608 W Broadway	Louisville	KY	40203-3518	Tom Levy	Owner/CEO	Phone 502-568-3030	Fax 502-568-3035	tomlevy@tomlevy.com, tlevy2009@aol.com

## Dugan McDermott

---

**From:** Dugan McDermott  
**Sent:** Tuesday, August 29, 2017 8:29 AM  
**To:** Dugan McDermott  
**Subject:** Expansion Area 3 Pump Station (Contract 1) Invitation to Bid  
**Attachments:** 20170829071807425.pdf

Good Morning,

Please find attached Invitation to bid for the Expansion Area 3 Pump Station (contract 1) project.

The Bid date is September 21, 2017 @ 2:00 pm. For instructions and project details please see attached letter. Plans and Specs are available upon request. All scopes and bids must be accompanied by the attached EPA forms.

Please let us know if you have any project specific questions.

Looking forward to hearing from you.

Regards,

**Dugan McDermott**

W. Rogers Company, LLC.

649 Bizzell Drive, Lexington, KY 40510

859.231.6290 Office Main

859.231.6296 Fax

859.410.7221 Direct

Email: [duganm@wrogers.com](mailto:duganm@wrogers.com)

Website: [www.wrogers.com](http://www.wrogers.com)



# W. ROGERS COMPANY

P.O Box 11640  
649 Bizzell Drive, Lexington KY 40510  
O: (859) 231-6290  
F: (859) 231-6296



## INVITATION TO BID

**Project Name:** Expansion Area 3 Pump Station (Contract 1)  
**Owner:** City of Lexington  
**Location:** Lexington, KY.  
**Bid Date:** September 21, 2017 @ 2:00 PM

### **Brief Description of the Project:**

The above referenced project generally consists of constructing a Class A Pumping Station with mechanical screens, screen compactors, four (4) submersible pumps, odor control equipment, A building with screen room, dumpster room, odor control room, electrical room, and emergency generator. Also included in this project is approximately 220 LF of 24" Force Main and 660 LF of 10" Gravity Sanitary sewer.

### **Bid Documents and Instructions to Suppliers and Subcontractors**

Plans and Specifications may be reviewed at our office. Please notify our office and we can make them available to you upon your arrival. If you wish to receive digital copies of the bid documents they can be provided upon request

The scope of supply should be received in our office no later than 24 hours prior to bid. Final pricing should be received a minimum of two (2) hours prior to bid time. Scopes and final pricing may be faxed to (859) 231-6296 or emailed to [duganm@wrogers.com](mailto:duganm@wrogers.com)

### **Opportunities for Supply and Subcontract Include but Are Not Limited To:**

Reinforcing Steel Placement  
Erosion Control  
Building Trades  
Electrical Construction  
Fencing / Landscaping  
Asphalt / Curb & Gutter  
Concrete Supply

Yard Pipe & Fittings  
HVAC / Plumbing  
Masonry  
Misc. Metals  
Earth Hauling / Excavating  
Aggregate Supply  
Blasting

Should any of the scopes of work be too large for your company to consider in its entirety, we will consider dividing the work into a more manageable size while still giving your firm due consideration. We request that you respond promptly whether you have any interest in this project using the form provided below. Should you have any project specific questions, please direct them to Dugan McDermott via the office number or email listed above. Thank you for your consideration and we look forward to hearing from you.

**Please Complete the Following Form and Return Via Fax Number Listed Above:**

Company Name _____	
Primary Contact _____	Bidding: Yes ___ No ___
Email Address: _____	
Phone: _____	Fax: _____
Would you like to continue to receive invitations to participate in upcoming opportunities from W Rogers Company? Yes ___ No ___	

*This transmittal is confidential and intended solely and exclusively for the individual identified above. If the recipient of this transmittal is not the identified above, please immediately notify the sender by telephone and delete this transmittal, please do not read, copy, distribute, or disseminate this transmittal.*

1.11 MWDBE SUBCONTRACTOR PERFORMANCE FORM



OMB Control No: 2090-0030  
 Approved: 8/13/2013  
 Approval Expires: 8/31/2015

**Disadvantaged Business Enterprise (DBE) Program  
 DBE Subcontractor Performance Form**

This form is intended to capture the DBE<sup>1</sup> subcontractor's<sup>2</sup> description of work to be performed and the price of the work submitted to the prime contractor. An EPA Financial Assistance Agreement Recipient must require its prime contractor to have its DBE subcontractors complete this form and include all completed forms in the prime contractor's bid or proposal package.

Subcontractor Name		Project Name	
Bid/ Proposal No.	Assistance Agreement ID No. (if known)	Point of Contact	
Address			
Telephone No.		Email Address	
Prime Contractor Name		Issuing/Funding Entity:	

Contract Item Number	Description of Work Submitted to the Prime Contractor Involving Construction, Services, Equipment or Supplies	Price of Work Submitted to the Prime Contractor
DBE Certified By: <input type="checkbox"/> DOT <input type="checkbox"/> SBA		Meets/ exceeds EPA certification standards?
<input type="checkbox"/> Other: _____		<input type="checkbox"/> YES <input type="checkbox"/> NO <input type="checkbox"/> Unknown

<sup>1</sup> A DBE is a Disadvantaged, Minority, or Woman Business Enterprise that has been certified by an entity from which EPA accepts certifications as described in 40 CFR 33.204-33.205 or certified by EPA. EPA accepts certifications from entities that meet or exceed EPA certification standards as described in 40 CFR 33.202.

<sup>2</sup> Subcontractor is defined as a company, firm, joint venture, or individual who enters into an agreement with a contractor to provide services pursuant to an EPA award of financial assistance.

**EPA FORM 6100-3 (DBE Subcontractor Performance Form)**

**Disadvantaged Business Enterprise (DBE) Program  
 DBE Subcontractor Performance Form**

I certify under penalty of perjury that the forgoing statements are true and correct. Signing this form does not signify a commitment to utilize the subcontractors above. I am aware of that in the event of a replacement of a subcontractor, I will adhere to the replacement requirements set forth in 40 CFR Part 33 Section 33.302 (c).

<b>Prime Contractor Signature</b>	<b>Print Name</b>
<b>Title</b>	<b>Date</b>

<b>Subcontractor Signature</b>	<b>Print Name</b>
<b>Title</b>	<b>Date</b>

The public reporting and recordkeeping burden for this collection of information is estimated to average three (3) hours per response. Send comments on the Agency's need for this information, the accuracy of the provided burden estimates, and any suggested methods for minimizing respondent burden, including through the use of automated collection techniques to the Director, Collection Strategies Division, U.S. Environmental Protection Agency (2822T), 1200 Pennsylvania Ave., NW, Washington, D.C. 20460 Include the OMB control number in any correspondence. Do not send the completed form to this address.

**EPA FORM 6100-3 (DBE Subcontractor Performance Form)**

**Display Solicitation Record**

Your solicitation has been entered in SUB-Net database. Thank you very much!

Prime's Name: **W Rogers Company**

Contact: **Dugan McDermott**

Address 1: **649 Bizzell Drive**

Address 2:

City: **LEXINGTON** State: **KY**

Zip: **40510** Zip+4:

Phone: **859-410-7221**

Fax: **859-231-6296**

Email: **Duganm@wrogers.com**

Seeking: • **US Department Of Transportation Disadvantaged Business Enterprise (DBE)**

• **Small Disadvantaged Business (SDB)**

• **Women Owned Small Business (WOSB)**

• **Veteran Owned Small Business (VOSB)**

• **Service-Disabled Veteran-Owned Small Business (SD-VOSB)**

Description: **INVITATION TO BID Project Name: Expansion Area 3 Pump Station (Contract 1) Owner: City of Lexington Location: Lexington, KY. Bid Date: September 21, 2017 @ 2:00 PM Brief Description of the Project: The above referenced project generally consists of constructing a Class A Pumping Station with mechanical screens, screen compactors, four (4) submersible pumps, odor control equipment, A building with screen room, dumpster room, odor control room, electrical room, and emergency generator. Also included in this project is approximately 220 LF of 24" Force Main and 660 LF of 10" Gravity Sanitary sewer. Bid Documents and Instructions to Suppliers and Subcontractors Plans and Specifications may be reviewed at our office. Please notify our office and we can make them available to you upon your arrival. If you wish to receive digital copies of the bid documents they can be provided upon request. The scope of supply should be received in our office no later than 24 hours prior to bid. Final pricing should be received a minimum of two (2) hours prior to bid time. Scopes and final pricing may be faxed to (859) 231-6296 or emailed to duganm@wrogers.com Opportunities for Supply and Subcontract Include but Are Not Limited To: Reinforcing Steel Placement Yard Pipe & Fittings Erosion Control HVAC / Plumbing Building Trades Masonry Electrical Construction Misc. Metals Fencing / Landscaping Earth Hauling / Excavating Asphalt / Curb & Gutter Aggregate Supply Concrete Supply Blasting Should any of the scopes of work be too large for your company to consider in its entirety, we will consider dividing the work into a more manageable size while still giving your firm due consideration. We request that you respond promptly whether you have any interest in this project using the form provided below. Should you have any project specific questions, please direct them to Dugan McDermott via the office number or email listed above.**

**Thank you for your consideration and we look forward to hearing from you.**

- NAICS Code: **238110**
- 238140**
- 238160**
- 238190**
- 238210**
- 238220**
- 238310**
- 238320**
- 238910**
- 238990**

Place of performance: **KY - Kentucky**

Prime Sol. Number:

Subcontract Sol. Number: **LFUCG92117**

Bid Closing Date: **9/21/2017**

Time: **1:00 PM EDT**

[Back](#)

This listing is from the SBA's **PRODUCTION** environment.

Window URL: [https://eweb1.sba.gov/subnet/update/profiles/dsp\\_company\\_entry\\_form.cfm](https://eweb1.sba.gov/subnet/update/profiles/dsp_company_entry_form.cfm)

Data region URL: [https://eweb1.sba.gov/subnet/search/dsp\\_detailed\\_bid\\_record.cfm?bid\\_seq\\_num=46868&extra\\_msg=Y](https://eweb1.sba.gov/subnet/search/dsp_detailed_bid_record.cfm?bid_seq_num=46868&extra_msg=Y)



## Dugan McDermott

---

**From:** Dugan McDermott  
**Sent:** Monday, September 25, 2017 12:58 PM  
**To:** 'Kimberly Imbro'  
**Subject:** RE: Expansion Area 3 Pump Station (Contract 1) Invitation to Bid

Thank you for the proposal,  
If applicable, please fill out a copy of the EPA forms that were attached in my original email.

Regards,

## Dugan McDermott

W. Rogers Company, LLC.  
649 Bizzell Drive, Lexington, KY 40510  
859.231.6290 Office Main  
859.231.6296 Fax  
859.410.7221 Direct  
Email: [duganm@wrogers.com](mailto:duganm@wrogers.com)  
Website: [www.wrogers.com](http://www.wrogers.com)



**From:** Kimberly Imbro [mailto:Kimbro@frewprocess.com]  
**Sent:** Monday, September 25, 2017 12:41 PM  
**To:** Dugan McDermott <duganm@wrogers.com>  
**Subject:** RE: Expansion Area 3 Pump Station (Contract 1) Invitation to Bid

Hi Dugan,  
I was out for vacation and have been here for the last week and a half on my own while others are in training. I was told this bids tomorrow. I sent the quote in first email and forgot to attached the data sheets.  
Thank you

---

### Kimberly Imbro Sales Associate

[Kimbro@frewprocess.com](mailto:Kimbro@frewprocess.com) • 317-565-5012 (O) • [www.FrewProcess.com](http://www.FrewProcess.com)  
15305 Stony Creek Way • Noblesville • IN • 46060 • United States



**Flow Metering | Valves & Safety Products | Heating & Steam Specialties | Process Control**  
**Delivering Solutions for Industrial & Utility Applications for Over 60 Years**

This message is confidential. It may also be privileged. It is either protected by work product, attorney-client, or legal rules. If you have received it by mistake, please let us know by e-mail, reply and delete it from your system. You may not copy, disseminate, or disclose its contents to anyone. Please send us by fax a copy of this message to the sender. If you are unable to make a copy, please let us know. The integrity and security of this message cannot be guaranteed on the Internet.

From: Dugan McDermott [<mailto:duganm@wrogers.com>]  
Sent: Tuesday, August 29, 2017 8:29 AM  
To: Dugan McDermott <[duganm@wrogers.com](mailto:duganm@wrogers.com)>  
Subject: Expansion Area 3 Pump Station (Contract 1) Invitation to Bid

Good Morning,  
Please find attached Invitation to bid for the Expansion Area 3 Pump Station (contract 1) project.  
The Bid date is September 21, 2017 @ 2:00 pm. For instructions and project details please see attached letter. Plans and Specs are available upon request. All scopes and bids must be accompanied by the attached EPA forms.  
Please let us know if you have any project specific questions.  
Looking forward to hearing from you.

Regards,

**Dugan McDermott**

W. Rogers Company, LLC.  
649 Bizzell Drive, Lexington, KY 40510  
859.231.6290 Office Main  
859.231.6296 Fax  
859.410.7221 Direct  
Email: [duganm@wrogers.com](mailto:duganm@wrogers.com)  
Website: [www.wrogers.com](http://www.wrogers.com)



DISCLAIMER: This e-mail and any attachments may contain confidential and privileged information. If you are not the intended recipient, please notify the sender immediately by return e-mail, delete this e-mail and destroy any copies. Any dissemination or use of this information by a person other than the intended recipient is unauthorized and may be illegal.

**Dugan McDermott**

---

**From:** Matt Gamlin <matt@mckinneypainting.com>  
**Sent:** Friday, September 22, 2017 12:13 PM  
**To:** Dugan McDermott  
**Subject:** RE: Expansion Area 3 Pump Station Contract 1

No sir.

Matthew Gamlin  
Vice President / Industrial Division Specialist  
McKinney Painting Inc.  
"A Womens Business Enterprise"  
Offices in Versailles, KY and Sellersburg, Indiana  
800-928-6424 Ext. 129 and 859-983-4515

**From:** Dugan McDermott [mailto:duganm@wrogers.com]  
**Sent:** Friday, September 22, 2017 9:42 AM  
**To:** Matt Gamlin <matt@mckinneypainting.com>  
**Subject:** Expansion Area 3 Pump Station Contract 1

Matt,  
Are you guys quoting the Area Expansion 3 Pump Station project bidding on the 26<sup>th</sup>?

Regards,

**Dugan McDermott**

W. Rogers Company, LLC.  
649 Bizzell Drive, Lexington, KY 40510  
859.231.6290 Office Main  
859.231.6296 Fax  
859.410.7221 Direct  
Email: [duganm@wrogers.com](mailto:duganm@wrogers.com)  
Website: [www.wrogers.com](http://www.wrogers.com)



**DISCLAIMER:** This e-mail and any attachments may contain confidential and privileged information. If you are not the intended recipient, please notify the sender immediately by return e-mail, delete this e-mail and destroy any copies. Any dissemination or use of this information by a person other than the intended recipient is unauthorized and may be illegal.

**Dugan McDermott**

---

**From:** Tanner McKenzie <tannerm@bluegrasscontracting.com>  
**Sent:** Monday, September 18, 2017 12:15 PM  
**To:** Dugan McDermott  
**Subject:** RE: [FWD: Expansion Area 3 Pump Station (Contract 1) Invitation to Bid]

Dugan:

We will not be submitting a quote for this project. Thanks for sending it over to us, we appreciate the opportunity.

Thanks,

**Tanner McKenzie, EIT**  
*Bluegrass Contracting Corporation*  
1075 Red Mile Road  
Lexington, KY 40504  
Office: (859) 231-0069  
Mobile: (606) 207-5017  
[tannerm@bluegrasscontracting.com](mailto:tannerm@bluegrasscontracting.com)

**From:** Dugan McDermott [mailto:duganm@wrogers.com]  
**Sent:** Tuesday, August 29, 2017 8:51 AM  
**To:** Tanner McKenzie <tannerm@bluegrasscontracting.com>  
**Subject:** RE: [FWD: Expansion Area 3 Pump Station (Contract 1) Invitation to Bid]

Tanner,

I will send over a sharefile link. Thank you for your interest. Let me know if you have any questions.

Regards,

**Dugan McDermott**  
W. Rogers Company, LLC.  
649 Bizzell Drive, Lexington, KY 40510  
859.231.6290 Office Main  
859.231.6296 Fax  
859.410.7221 Direct  
Email: [duganm@wrogers.com](mailto:duganm@wrogers.com)  
Website: [www.wrogers.com](http://www.wrogers.com)



From: Tanner McKenzie [<mailto:tannerm@bluegrasscontracting.com>]  
Sent: Tuesday, August 29, 2017 8:47 AM  
To: Dugan McDermott <[duganm@wrogers.com](mailto:duganm@wrogers.com)>  
Subject: RE: [FWD: Expansion Area 3 Pump Station (Contract 1) Invitation to Bid]

Dugan:

Can you send me a copy of the plans and specs on this project?

Thanks,

**Tanner McKenzie, EIT**  
Bluegrass Contracting Corporation  
1075 Red Mile Road  
Lexington, KY 40504  
Office: (859) 231-0069  
Mobile: (606) 207-5017  
[tannerm@bluegrasscontracting.com](mailto:tannerm@bluegrasscontracting.com)

----- Original Message -----

Subject: Expansion Area 3 Pump Station (Contract 1) Invitation to Bid  
From: Dugan McDermott <[duganm@wrogers.com](mailto:duganm@wrogers.com)>  
Date: Tue, August 29, 2017 8:28 am  
To: Dugan McDermott <[duganm@wrogers.com](mailto:duganm@wrogers.com)>

Good Morning,  
Please find attached Invitation to bid for the Expansion Area 3 Pump Station (contract 1) project.  
The Bid date is September 21, 2017 @ 2:00 pm. For instructions and project details please see attached letter. Plans and Specs are available upon request. All scopes and bids must be accompanied by the attached EPA forms.  
Please let us know if you have any project specific questions.  
Looking forward to hearing from you.

Regards,

**Dugan McDermott**  
W. Rogers Company, LLC.  
649 Bizzell Drive, Lexington, KY 40510  
859.231.6290 Office Main  
859.231.6296 Fax  
859.410.7221 Direct  
Email: [duganm@wrogers.com](mailto:duganm@wrogers.com)  
Website: [www.wrogers.com](http://www.wrogers.com)



**DISCLAIMER:** This e-mail and any attachments may contain confidential and privileged information. If you are not the intended recipient, please notify the sender immediately by return e-mail, delete this e-mail and destroy any copies. Any dissemination or use of this information by a person other than the intended recipient is unauthorized and may be illegal.

## Dugan McDermott

---

**From:** Dugan McDermott  
**Sent:** Thursday, September 7, 2017 1:41 PM  
**To:** 'office@bison-services.com'  
**Subject:** EA3 Pump Station Project Invitation to bid  
**Attachments:** 20170829071807425.pdf

Good Afternoon,

We are bidding a project in Lexington on September, 21. The project generally consists of a large pump station which includes an HVAC scope. I was hoping you may be interested in taking a look and putting together a proposal for us. Please let us know if you need digital bid documents or if you have any project specific questions.

Regards,

**Dugan McDermott**

W. Rogers Company, LLC.  
649 Bizzell Drive, Lexington, KY 40510  
859.231.6290 Office Main  
859.231.6296 Fax  
859.410.7221 Direct  
Email: [duganm@wrogers.com](mailto:duganm@wrogers.com)  
Website: [www.wrogers.com](http://www.wrogers.com)



**Dugan McDermott**

**From:** Dugan McDermott  
**Sent:** Tuesday, September 5, 2017 1:56 PM  
**To:** 'Pleasant Marks'  
**Subject:** RE: Expansion Area 3 Pump Station (Contract 1) Invitation to Bid

Jey,  
I will put together a scope with quantities for you to price by the end of the week.  
Please let me know if you have any further questions.  
Do you have a good disposal site for excess soil material?

Regards,

**Dugan McDermott**

W. Rogers Company, LLC.  
649 Bizzell Drive, Lexington, KY 40510  
859.231.6290 Office Main  
859.231.6296 Fax  
859.410.7221 Direct  
Email: [duganm@wrogers.com](mailto:duganm@wrogers.com)  
Website: [www.wrogers.com](http://www.wrogers.com)



**From:** Pleasant Marks [mailto:[pleasantmarkstrucking@gmail.com](mailto:pleasantmarkstrucking@gmail.com)]  
**Sent:** Tuesday, September 5, 2017 1:50 PM  
**To:** Dugan McDermott <[duganm@wrogers.com](mailto:duganm@wrogers.com)>  
**Subject:** Re: Expansion Area 3 Pump Station (Contract 1) Invitation to Bid

Mr. McDermott,

I am interested in offering a bid for the hauling of stone and removal of dirt for the job. But would estimates (Tonnage of Rock needed / Square Ft. of earth to remove and Haul) in order to bid this for you.

Thank you for your time,

-Jey

On Tue, Aug 29, 2017 at 8:28 AM, Dugan McDermott <[duganm@wrogers.com](mailto:duganm@wrogers.com)> wrote:

Good Morning,



Please find attached Invitation to bid for the Expansion Area 3 Pump Station (contract 1) project.

The Bid date is September 21, 2017 @ 2:00 pm. For instructions and project details please see attached letter. Plans and Specs are available upon request. All scopes and bids must be accompanied by the attached EPA forms.

Please let us know if you have any project specific questions.

Looking forward to hearing from you.

Regards,

**Dugan McDermott**

W. Rogers Company, LLC.

649 Bizzell Drive, Lexington, KY 40510

859.231.6290 Office Main

859.231.6296 Fax

859.410.7221 Direct

Email: [duganm@wrogers.com](mailto:duganm@wrogers.com)

Website: [www.wrogers.com](http://www.wrogers.com)



DISCLAIMER: This e-mail and any attachments may contain confidential and privileged information. If you are not the intended recipient, please notify the sender immediately by return e-mail, delete this e-mail and destroy any copies. Any dissemination or use of this information by a person other than the intended recipient is unauthorized and may be illegal.

--

 **Pleasant Marks Group**

**Dugan McDermott**

---

**From:** Talan Weaver <talán@hausners.com>  
**Sent:** Tuesday, August 29, 2017 1:02 PM  
**To:** Dugan McDermott  
**Subject:** RE: Expansion Area 3 Pump Station (Contract 1) Invitation to Bid

We will be declining, thank you.

**Talan Weaver**

**Hausners Precast**

**918-352-3479**

**From:** Dugan McDermott [mailto:duganm@wrogers.com]  
**Sent:** Tuesday, August 29, 2017 7:29 AM  
**To:** Dugan McDermott <duganm@wrogers.com>  
**Subject:** Expansion Area 3 Pump Station (Contract 1) Invitation to Bid

Good Morning,

Please find attached Invitation to bid for the Expansion Area 3 Pump Station (contract 1) project. The Bid date is September 21, 2017 @ 2:00 pm. For instructions and project details please see attached letter. Plans and Specs are available upon request. All scopes and bids must be accompanied by the attached EPA forms. Please let us know if you have any project specific questions.

Joking forward to hearing from you.

Regards,

**Dugan McDermott**

W. Rogers Company, LLC.  
649 Bizzell Drive, Lexington, KY 40510  
859.231.6290 Office Main  
859.231.6296 Fax  
859.410.7221 Direct  
Email: [duganm@wrogers.com](mailto:duganm@wrogers.com)  
Website: [www.wrogers.com](http://www.wrogers.com)



**DISCLAIMER:** This e-mail and any attachments may contain confidential and privileged information. If you are not the intended recipient, please notify the sender immediately by return e-mail, delete this e-mail and destroy any copies. Any dissemination or use of this information by a person other than the intended recipient is unauthorized and may be illegal.

## Dugan McDermott

---

**From:** Dugan McDermott  
**Sent:** Tuesday, August 29, 2017 11:34 AM  
**To:** 'Zak Stanfield'  
**Subject:** RE: Expansion Area 3 Pump Station (Contract 1) Invitation to Bid

Zak,

Sharefile link has been sent containing the bid documents. Please let me know if you have any questions. If you submit a proposal please attach the EPA forms included in the transmittal on the invitation.

Regards,

### Dugan McDermott

W. Rogers Company, LLC.  
649 Bizzell Drive, Lexington, KY 40510  
859.231.6290 Office Main  
859.231.6296 Fax  
859.410.7221 Direct  
Email: [duganm@wrogers.com](mailto:duganm@wrogers.com)  
Website: [www.wrogers.com](http://www.wrogers.com)



**From:** Zak Stanfield [mailto:[zaktheinstaller@gmail.com](mailto:zaktheinstaller@gmail.com)]  
**Sent:** Tuesday, August 29, 2017 11:05 AM  
**To:** Dugan McDermott <[duganm@wrogers.com](mailto:duganm@wrogers.com)>  
**Subject:** Re: Expansion Area 3 Pump Station (Contract 1) Invitation to Bid

Yes, we are interested.

On Aug 29, 2017 8:28 AM, "Dugan McDermott" <[duganm@wrogers.com](mailto:duganm@wrogers.com)> wrote:

Good Morning,

Please find attached Invitation to bid for the Expansion Area 3 Pump Station (contract 1) project.

The Bid date is September 21, 2017 @ 2:00 pm. For instructions and project details please see attached letter. Plans and Specs are available upon request. All scopes and bids must be accompanied by the attached EPA forms.

Please let us know if you have any project specific questions.

Looking forward to hearing from you.

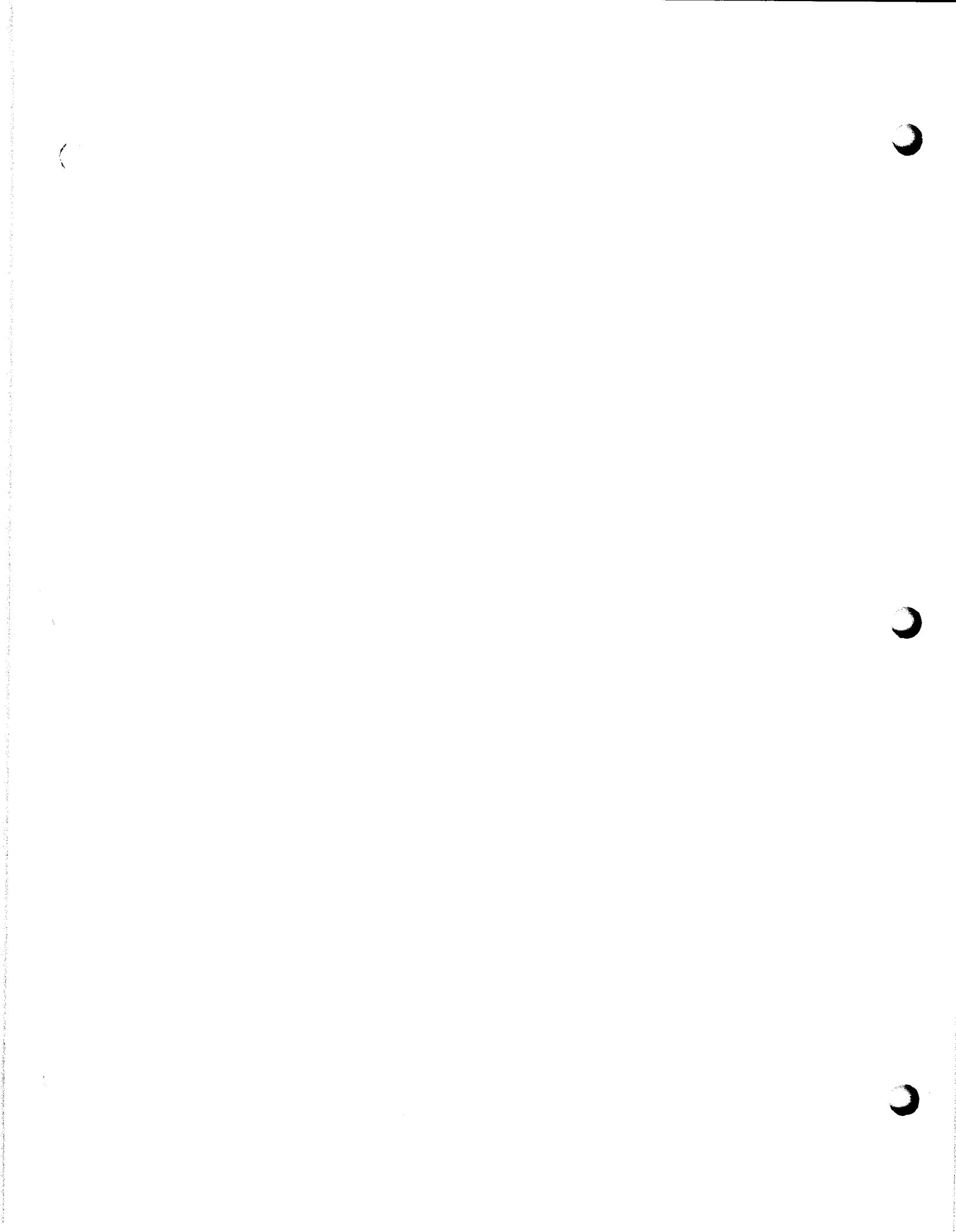

Regards,

## Dugan McDermott

W. Rogers Company, LLC.

649 Bizzell Drive, Lexington, KY 40510

859.231.6290 Office Main

859.231.6296 Fax

859.410.7221 Direct

Email: [duganm@wrogers.com](mailto:duganm@wrogers.com)

Website: [www.wrogers.com](http://www.wrogers.com)



**DISCLAIMER:** This e-mail and any attachments may contain confidential and privileged information. If you are not the intended recipient, please notify the sender immediately by return e-mail, delete this e-mail and destroy any copies. Any dissemination or use of this information by a person other than the intended recipient is unauthorized and may be illegal.

**Dugan McDermott**

---

**From:** Dugan McDermott  
**Sent:** Monday, September 25, 2017 3:36 PM  
**To:** 'Jessica@m-mmanufacturing.com'  
**Subject:** Expansion Area 3 (contract 1)  
**Attachments:** 20170829071807425.pdf

Ms. Vaughn,  
Thank you for your scope, This project requires the EPA forms to be filled out for all MWDBE subcontractors bidding the work. Please attach the forms to your final proposal.  
I have attached a copy of the forms if you do not already have them.

Regards,

**Dugan McDermott**

W. Rogers Company, LLC.  
649 Bizzell Drive, Lexington, KY 40510  
859.231.6290 Office Main  
859.231.6296 Fax  
859.410.7221 Direct  
Email: [duganm@wrogers.com](mailto:duganm@wrogers.com)  
Website: [www.wrogers.com](http://www.wrogers.com)



## Dugan McDermott

---

**From:** Robin Fugate  
**Sent:** Monday, September 25, 2017 3:30 PM  
**To:** Dugan McDermott  
**Subject:** FW: Lexington, KY Expansion Area #3 Scope  
**Attachments:** Lexington, KY Expansion Area #3 Scope.pdf; Terms and Conditions.pdf

FYI

**From:** Jessica Vaughn [mailto:jessica@m-mmanufacturing.com]  
**Sent:** Monday, September 25, 2017 3:23 PM  
**To:** Daniel Hodges <daniel@m-mmanufacturing.com>  
**Subject:** Lexington, KY Expansion Area #3 Scope

See attached scope for the Lexington, KY - Expansion Area #3 project which bids tomorrow. Please let me know if you have any questions, thanks!

Thanks,

Jessica McBride Vaughn

M & M Manufacturing, Inc.  
709 Sportsman Lake Road  
Franklin, KY 42134

PH: 270.586.8208  
FAX: 270.586.6424  
[Jessica@m-mmanufacturing.com](mailto:Jessica@m-mmanufacturing.com)

Check us out online at -  
[www.m-mmanufacturing.com](http://www.m-mmanufacturing.com)

**Dugan McDermott**

---

**From:** Scott Braun <thefencecoofky@gmail.com>  
**Sent:** Tuesday, September 26, 2017 11:04 AM  
**To:** Dugan McDermott  
**Subject:** Re: EPA Forms

Dugan

Alternate for scale wages is \$ 4,575.00 . Judy is sending you the EPA forms in a few minutes .Good luck on the bid today please let me know how it turns out .

thank You  
Scott Braun

On Tue, Sep 26, 2017 at 9:55 AM, Dugan McDermott <[duganm@wrogers.com](mailto:duganm@wrogers.com)> wrote:

Scott, attached are the EPA forms required. Thank you for your proposal and looking forward to your Alt price for Scale

Regards,

**Dugan McDermott**

W. Rogers Company, LLC.

649 Bizzell Drive, Lexington, KY 40510

859.231.6290 Office Main

859.231.6296 Fax

859.410.7221 Direct

Email: [duganm@wrogers.com](mailto:duganm@wrogers.com)

Website: [www.wrogers.com](http://www.wrogers.com)





# NORWOOD HARDWARE



## QUOTATION

NORWOOD HARDWARE AND SUPPLY CO.  
2906 Glendale-Milford Road, Cincinnati, Ohio 45241  
Phone: (513) 733-1175 / Fax (513) 733-8867

UPDATED

DATE: 9/26/2017  
PROPOSAL: \_\_\_\_\_  
GOOD THRU: 10/26/2017

TO: GENERAL CONTRACTORS BIDDING  
\_\_\_\_\_  
\_\_\_\_\_

PROJECT: LEXINGTON AREA 3 PS/FORCE  
MAIN (MATERIAL PROPOSAL)  
OWNER: LFCUG

The materials to be furnished under this proposal are limited to those described below and as specified in specifications and architectural drawings dated 8/2017 by HDR  
Addenda (s) 1,2,3,4,5,6,7,8 is acknowledged.  
Original Quotation: XX Change Order Quotation: \_\_\_\_\_

ITEM	QUANTITY	DESCRIPTION	\$
		<b>08342 FIBERGLASS DOORS AND DOOR FRAMES</b>	
		- 15 DOORS/11 FRAMES (4 SINGLE/3 PAIR)	
		- DOORS FACTORY GLAZED (1" IGU/CLEAR)	
		- GEL COAT FINISH	
		<b>08710 FINISH HARDWARE</b>	
		- AS LISTED IN SETS	
		<b>TOTAL:</b>	<b>\$29,112.00</b>
			PLUS
			TAX
		<i>Note: Material only, installation not included unless noted otherwise.</i>	
		<i>Note: All prices exclude sales tax unless noted otherwise.</i>	

QUOTATION BASED ON COMPLETE MATERIAL RELEASE WITHIN 90 CALENDAR DAYS FROM DATE OF BID.  
MATERIAL RELEASE AFTER 90 DAYS FROM DATE OF BID WILL BE SUBJECT TO POTENTIAL MANUFACTURER SURCHARGES

### TERMS: NET 30 DAYS - NO RETENTION

All terms and conditions of this quotation are printed on the reverse side and form an integral part of this quotation.  
PLEASE READ THOROUGHLY.

ACCEPTED BY: \_\_\_\_\_  
TITLE: \_\_\_\_\_  
DATE: \_\_\_\_\_

Respectfully submitted:  
NORWOOD HARDWARE & SUPPLY CO. INC.  
BY: CRAIG CHABOT AHC/CDC/CS

(s) materials required: \_\_\_\_\_  
\_\_\_\_\_

Accepted:  
NORWOOD HARDWARE & SUPPLY CO. INC.  
BY: \_\_\_\_\_  
(Authorized Officer)

## 1.11 MWDBE SUBCONTRACTOR PERFORMANCE FORM

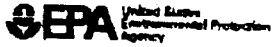

DBE Control No: 2090-0030  
 Approved: 8/13/2013  
 Approval Expires: 8/31/2015

Disadvantaged Business Enterprise (DBE) Program  
 DBE Subcontractor Performance Form

This form is intended to capture the DBE<sup>1</sup> subcontractor's<sup>2</sup> description of work to be performed and the price of the work submitted to the prime contractor. An EPA Financial Assistance Agreement Recipient must require its prime contractor to have its DBE subcontractors complete this form and include all completed forms in the prime contractor's bid or proposal package.

Subcontractor Name <b>NORWOOD HARDWARE</b>		Project Name <b>CORNINGTON PG/FORCEMAN</b>
Bid/ Proposal No.	Assistance Agreement ID No. (if known)	Point of Contact
Address <b>2906 SENECA-MILFORD ROAD CINCINNATI, OH 45244</b>		
Telephone No. <b>513.733.1175</b>	Email Address <b>CHABOT@NORWOODHARDWARE.COM</b>	
Prime Contractor Name		Issuing/Funding Entity:

Contract Item Number	Description of Work Submitted to the Prime Contractor Involving Construction, Services, Equipment or Supplies	Price of Work Submitted to the Prime Contractor
SPEC SECTIONS 08342 08910	ERP DOORS/FRAMES } FINISH HARDWARE }	\$29,112.00 TAX
DBE Certified By: <u>DOT</u> <u>SBA</u> <input checked="" type="checkbox"/> Other: <u>WBENC</u>		Meets/exceeds EPA certification standards? <input checked="" type="checkbox"/> YES <input type="checkbox"/> NO <input type="checkbox"/> Unknown

<sup>1</sup> A DBE is a Disadvantaged, Minority, or Women Business Enterprise that has been certified by an entity from which EPA accepts certifications as described in 40 CFR 33.204-33.205 or certified by EPA. EPA accepts certifications from entities that meet or exceed EPA certification standards as described in 40 CFR 33.202.

<sup>2</sup> Subcontractor is defined as a company, firm, joint venture, or individual who enters into an agreement with a contractor to provide services pursuant to an EPA award of financial assistance.

EPA FORM 6100-3 (DBE Subcontractor Performance Form)

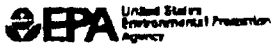

OMB Control No: 2090-0030  
Approved: 8/23/2013  
Approval Expires: 8/31/2015

**Disadvantaged Business Enterprise (DBE) Program  
DBE Subcontractor Performance Form**

I certify under penalty of perjury that the foregoing statements are true and correct. Signing this form does not signify a commitment to utilize the subcontractors above. I am aware of that in the event of a replacement of a subcontractor, I will adhere to the replacement requirements set forth in 40 CFR Part 33 Section 33.302 (c).

<b>Prime Contractor Signature</b>	<b>Print Name</b>
<b>Title</b>	<b>Date</b>

<b>Subcontractor Signature</b>	<b>Print Name</b>
<i>[Signature]</i>	<i>CRIG YUBA</i>
<b>Title</b>	<b>Date</b>
<i>VP</i>	<i>9/26/17</i>

The public reporting and recordkeeping burden for this collection of information is estimated to average three (3) hours per response. Send comments on the Agency's need for this information, the accuracy of the provided burden estimates, and any suggested methods for minimizing respondent burden, including through the use of automated collection techniques to the Director, Collection Strategies Division, U.S. Environmental Protection Agency (2822T), 1200 Pennsylvania Ave., NW, Washington, D.C. 20460. Include the OMB control number in any correspondence. Do not send the completed form to this address.

**EPA FORM 6100-3 (DBE Subcontractor Performance Form)**

# W. ROGERS COMPANY

P.O. Box 11640  
649 Bizzell Drive, Lexington KY 40510  
O: (859) 231-6290  
F: (859) 231-6296



## INVITATION TO BID

Project Name: Expansion Area 3 Pump Station (Contract 1)  
Owner: City of Lexington  
Location: Lexington, KY.  
Bid Date: September 21, 2017 @ 2:00 PM

### Brief Description of the Project:

The above referenced project generally consists of constructing a Class A Pumping Station with mechanical screens, screen compactors, four (4) submersible pumps, odor control equipment, A building with screen room, dumpster room, odor control room, electrical room, and emergency generator. Also included in this project is approximately 220 LF of 24" Force Main and 660 LF of 10" Gravity Sanitary sewer.

### Bid Documents and Instructions to Suppliers and Subcontractors

Plans and Specifications may be reviewed at our office. Please notify our office and we can make them available to you upon your arrival. If you wish to receive digital copies of the bid documents they can be provided upon request.

The scope of supply should be received in our office no later than 24 hours prior to bid. Final pricing should be received a minimum of two (2) hours prior to bid time. Scopes and final pricing may be faxed to (859) 231-6296 or emailed to [duganm@wrogers.com](mailto:duganm@wrogers.com)

### Opportunities for Supply and Subcontract Include but Are Not Limited To:

Reinforcing Steel Placement  
Erosion Control  
Building Trades  
Electrical Construction  
Fencing / Landscaping  
Asphalt / Curb & Gutter  
Concrete Supply

Yard Pipe & Fittings  
HVAC / Plumbing  
Masonry  
Misc. Metals  
Barb Hauling / Excavating  
Aggregate Supply  
Blasting

Should any of the scopes of work be too large for your company to consider in its entirety, we will consider dividing the work into a more manageable size while still giving your firm due consideration. We request that you respond promptly whether you have any interest in this project using the forms provided below. Should you have any project specific questions, please direct them to Dugan McDermott via the office number or email listed above. Thank you for your consideration and we look forward to hearing from you.

Please Complete the Following Form and Return Via Fax Number Listed Above:

Company Name	<u>The Fence Co</u>	Bidding: Yes / No
Primary Contact	<u>Scott Brown</u>	
Email Address:	<u>thefenceco@ky.com</u>	
Phone	<u>270 259 3808</u>	Fax: <u>270 259 0800</u>
Would you like to continue to receive invitations to participate in upcoming opportunities from W Rogers Company? Yes / No		

This transmittal is confidential and intended solely and exclusively for the individual identified above. If the recipient of this transmittal is not the identified above, please immediately notify the sender by telephone and delete this transmittal; please do not read, copy, distribute, or disseminate this transmittal.

1.10 MWDBE SUBCONTRACTOR PARTICIPATION FORM



OMB Control No: 2090-0030  
 Approved: 8/13/2013  
 Approval Expires: 8/31/2015

Disadvantaged Business Enterprise (DBE) Program  
 DBE Subcontractor Participation Form

An EPA Financial Assistance Agreement Recipient must require its prime contractors to provide this form to its DBE subcontractors. This form gives a DBE<sup>1</sup> subcontractor<sup>2</sup> the opportunity to describe work received and/or report any concerns regarding the EPA-funded project (e.g., in areas such as termination by prime contractor, late payments, etc.). The DBE subcontractor can, as an option, complete and submit this form to the EPA DBE Coordinator at any time during the project period of performance.

Subcontractor Name <i>The Fence Co</i>		Project Name	
Bid/ Proposal No.	Assistance Agreement ID No. (if known)	Point of Contact	
Address <i>197 Mohawk Ln Letchford Ky 42754</i>			
Telephone No. <i>(270) 259-3808</i>	Email Address <i>thefencecoofky@gmail.com</i>		
Prime Contractor Name	Issuing/Funding Entity:		

Contract Item Number	Description of Work Received from the Prime Contractor Involving Construction, Services, Equipment or Supplies	Amount Received by Prime Contractor
<i>1</i>	<i>Fencing</i>	

<sup>1</sup> A DBE is a Disadvantaged, Minority, or Woman Business Enterprise that has been certified by an entity from which EPA accepts certifications as described in 40 CFR 33.204-33.205 or certified by EPA. EPA accepts certifications from entities that meet or exceed EPA certification standards as described in 40 CFR 33.207.

<sup>2</sup> Subcontractor is defined as a company, firm, joint venture, or individual who enters into an agreement with a contractor to provide services pursuant to an EPA award of financial assistance.

EPA FORM 6100-2 (DBE Subcontractor Participation Form)

**Disadvantaged Business Enterprise (DBE) Program  
 DBE Subcontractor Participation Form**

Please use the space below to report any concerns regarding the above EPA-funded project:

---

---

---

---

---

---

---

---

---

---

---

---

---

---

---

---

---

---

---

---

---

---

---

---

<b>Subcontractor Signature</b>	<b>Print Name</b>
<i>Judy Braun</i>	Judy Braun
Title	Date
President	9/26/17

The public reporting and recordkeeping burden for this collection of information is estimated to average three (3) hours per response. Send comments on the Agency's need for this information, the accuracy of the provided burden estimates, and any suggested methods for minimizing respondent burden, including through the use of automated collection techniques to the Director, Collection Strategies Division, U.S. Environmental Protection Agency (2822T), 1200 Pennsylvania Ave., NW, Washington, D.C. 20460. Include the OMB control number in any correspondence. Do not send the completed form to this address.

EPA FORM 6100-2 (DBE Subcontractor Participation Form)

The Fence Co. LLC  
197 Mohawk Lane  
Leitchfield, KY 42754  
O (270) 259-3808  
F (270) 259-0300  
C (270)287-1134  
[thefencecoofky@gmail.com](mailto:thefencecoofky@gmail.com)

Estimate September 25 - 2017

Expansion Area 3 Pump Station And Force Main Improvements LFUCG  
Division Of Water Quality Lexington Kentucky

To furnish and install 2 - 20' x 4' aluminum double drive gates  
To furnish and install 2 - 12' single farm gates  
To furnish and install 1,137' of 4board wood plank fencing  
To furnish and install 535' of temporary woven wire fencing at the Poole Property

To Include  
6" treated wooden post  
1x6 treated plank boards with 1 x 6 treated face boards  
2 - 20' aluminum double drive gates with 4" gate post  
2 - 12' single farm gates  
All wooden post driven construction  
All wooden fencing painted 2 coats of black paint  
All gate post set in concrete

*Some / new fence*

Total: \$ 36,600.00

Temporary Fence Rates

To furnish and install 6' x 10' wide temporary fencing using panel design with concrete or metal stands \$ 4.00 per ft.  
Price is good for one time set up and removal with no monthly rental fees price is good for duration of project. If double drive construction gates are needed the price is 16' - 20' \$ 450.00 21' - 30' \$ 650.00 per set with 4" gate post set in concrete or driven construction contractors option.

Missing or Damaged Temporary Fencing

Missing or damaged temporary fence panels \$ 80.00 each  
Missing or damaged Concrete black stands \$ 30.00 each  
Missing or damaged metal stands \$ 20.00 each  
Missing or damaged kennel clamps \$ 4.00 per set

Rock Clause

If solid is encountered there is a charge of \$ 75.00 per hour for jackhammering minimum 2 hours  
The Fence Co LLC is not responsible for any underground utilities that may be encountered

If you intend on using The Fence Co LLC for this project please let us know so we can lock in the current material pricing and allow for scheduling

\_\_\_\_\_  
Responsible Party

\_\_\_\_\_  
Date

Thank You  
Scott Braun

WBE/DBS Certified  
SBA/HUB Zone Certified  
American Fence Association Certified Fence Professionals



Not Low

*M. C. M. Manufacturing, Inc.*

709 Sportsman Lake Road

Franklin, Kentucky 42134

Phone: (270) 586-8208

Fax: (270) 586-6424

www.mcmmanufacturing.com

September 26, 2017

**Expansion Area #3**

**Lexington, KY**

**-Quote-**

**Flowmeter Vault (Sheet 01C-07)**

\*Ladder by others

\*Hatches by others

**Master Meter Vault (Sheet 01C-07)**

\*Ladder by others

\*Hatches by others

**Backflow Preventer Vault (Sheet 01C-07)**

\*No metals

\*Hatches by others

**Detention Basin Outlet Structure (Sheet 01C-07)**

\*Trash rack by others

\*All metals by others

**Pump Station**

1. (30) 6" Schedule 40 primed steel pipe bollards at 6' 6" each
2. Approximately 40 LF 1 ½" aluminum handrail with toeboard
3. Approximately 215 SF aluminum plank grating with aluminum supports
4. (3) W16 x 31# Primed steel lintels with 3/8" x 11" plates at Overhead doors D-1, D-8 & D-11 (Sheet 01A-03)
5. (89) Anchor bolts with plate washers at the nailer
6. ¼" Primed steel plates with bolts at the diagonal braces (Sheet 01S-13)
7. (3) Aluminum ladders at 10' 6" high with ladder ups (Sheet 01D-02)

**Dumpster Area**

8. (1) ¾" Primed steel plate 1' wide x 13' 11" long with nelson studs  
\*If larger plate is required there will be a price increase
9. (1) ¾" Primed steel plate 10' wide x 32' long with epoxy anchors  
\*If larger plate is required there will be a price increase  
\*Plate is welded as one piece, it will weigh over 10,000 pounds
10. (2) HSS 4 ½" x 4 ½" x ¼" primed steel guide rails with ¼" cap plates



- \*All mechanical bar screens by others
- \*All screen compactor/conveyors by others
- \*All slide gates and sluice gates by others
- \*All pipe supports by others
- \*All guide rails and stem guides by others
- \*All roof hatches by others
- \*Freight to Lexington, KY included in quote
- \*M & M Manufacturing, Inc. is not AISC certified

**DELIVERED TOTAL: \$79,390.00**

**\*ADD FOR HATCHES:**

- (4) 3' 6" x 4' 6" Aluminum hatches at the Valve Vault
- (1) 2' 6" x 2' 6" Aluminum hatch at the Valve Vault
- (3) 2' 6" x 3' Aluminum hatches at the Valve Vault
  
- (4) 3' 6" x 4' 6" Aluminum hatches at the Wet Well
- (2) 2' 6" x 3' Aluminum hatches at the Wet Well
- (2) 3' x 3' Aluminum hatches at the Wet Well

- \*Hatches are not H20 rated
- \*All hatches at the Flowmeter Vault, Master Meter Vault & Backflow Preventer Vault by others
- \*All roof hatches by others

**ADD FOR (16) HATCHES: \$21,925.00**

*This quote is subject to the attached terms. Please call with any additions and/or deletions. Plus tax if applicable.*

Thanks,  
 Jessica Vaughn  
[Jessica@m-mmanufacturing.com](mailto:Jessica@m-mmanufacturing.com)

**DBE Certified** by the: *State of Kentucky Transportation Cabinet*

Certified as a **WBE** by the:



Approved by the: **Louisville MSD** Louisville Jefferson County Metro Sewer District

1.11 MWDBE SUBCONTRACTOR PERFORMANCE FORM



OMB Control No: 2090-0030  
 Approved: 8/13/2013  
 Approval Expires: 8/31/2015

Disadvantaged Business Enterprise (DBE) Program  
 DBE Subcontractor Performance Form

This form is intended to capture the DBE<sup>1</sup> subcontractor's<sup>2</sup> description of work to be performed and the price of the work submitted to the prime contractor. An EPA Financial Assistance Agreement Recipient must require its prime contractor to have its DBE subcontractors complete this form and include all completed forms in the prime contractor's bid or proposal package.

Subcontractor Name <b>M+M Manufacturing, Inc.</b>		Project Name <b>Lexington, Ky Expansion Area 3</b>	
Bid/ Proposal No.	Assistance Agreement ID No. (if known)	Point of Contact	
Address <b>709 Sportsman Lake Road, Franklin, Ky 42134</b>			
Telephone No. <b>270-536-8208</b>	Email Address <b>Jessica@m-mmanufacturing.com</b>		
Prime Contractor Name		Issuing/Funding Entity.	

Contract Item Number	Description of Work Submitted to the Prime Contractor Involving Construction, Services, Equipment or Supplies	Price of Work Submitted to the Prime Contractor
	Misc. Metals	\$79,390.00
	Add for Hatches	\$21,925.00
	<b>Total</b>	<b>\$101,315.00</b>

DBE Certified By:  DOT  SBA  Other: \_\_\_\_\_

Meets/ exceeds EPA certification standards?  
 YES  NO  Unknown

<sup>1</sup> A DBE is a Disadvantaged, Minority, or Woman Business Enterprise that has been certified by an entity from which EPA accepts certifications as described in 40 CFR 33.204-33.205 or certified by EPA. EPA accepts certifications from entities that meet or exceed EPA certification standards as described in 40 CFR 33.202.

<sup>2</sup> Subcontractor is defined as a company, firm, joint venture, or individual who enters into an agreement with a contractor to provide services pursuant to an EPA award of financial assistance.

EPA FORM 6100-3 (DBE Subcontractor Performance Form)

**Disadvantaged Business Enterprise (DBE) Program  
 DBE Subcontractor Performance Form**

I certify under penalty of perjury that the forgoing statements are true and correct. Signing this form does not signify a commitment to utilize the subcontractors above. I am aware of that in the event of a replacement of a subcontractor, I will adhere to the replacement requirements set forth in 40 CFR Part 33 Section 33.302 (c).

<b>Prime Contractor Signature</b>	<b>Print Name</b>
<b>Title</b>	<b>Date</b>

<b>Subcontractor Signature</b>	<b>Print Name</b>
<i>Jessica Vaughn</i>	<i>Jessica Vaughn</i>
<b>Title</b>	<b>Date</b>
<i>Project Manager</i>	<i>9/26/17</i>

The public reporting and recordkeeping burden for this collection of information is estimated to average three (3) hours per response. Send comments on the Agency's need for this information, the accuracy of the provided burden estimates, and any suggested methods for minimizing respondent burden, including through the use of automated collection techniques to the Director, Collection Strategies Division, U.S. Environmental Protection Agency (2822T), 1200 Pennsylvania Ave., NW, Washington, D.C. 20460. Include the OMB control number in any correspondence. Do not send the completed form to this address.

EPA FORM 6100-3 (DBE Subcontractor Performance Form)

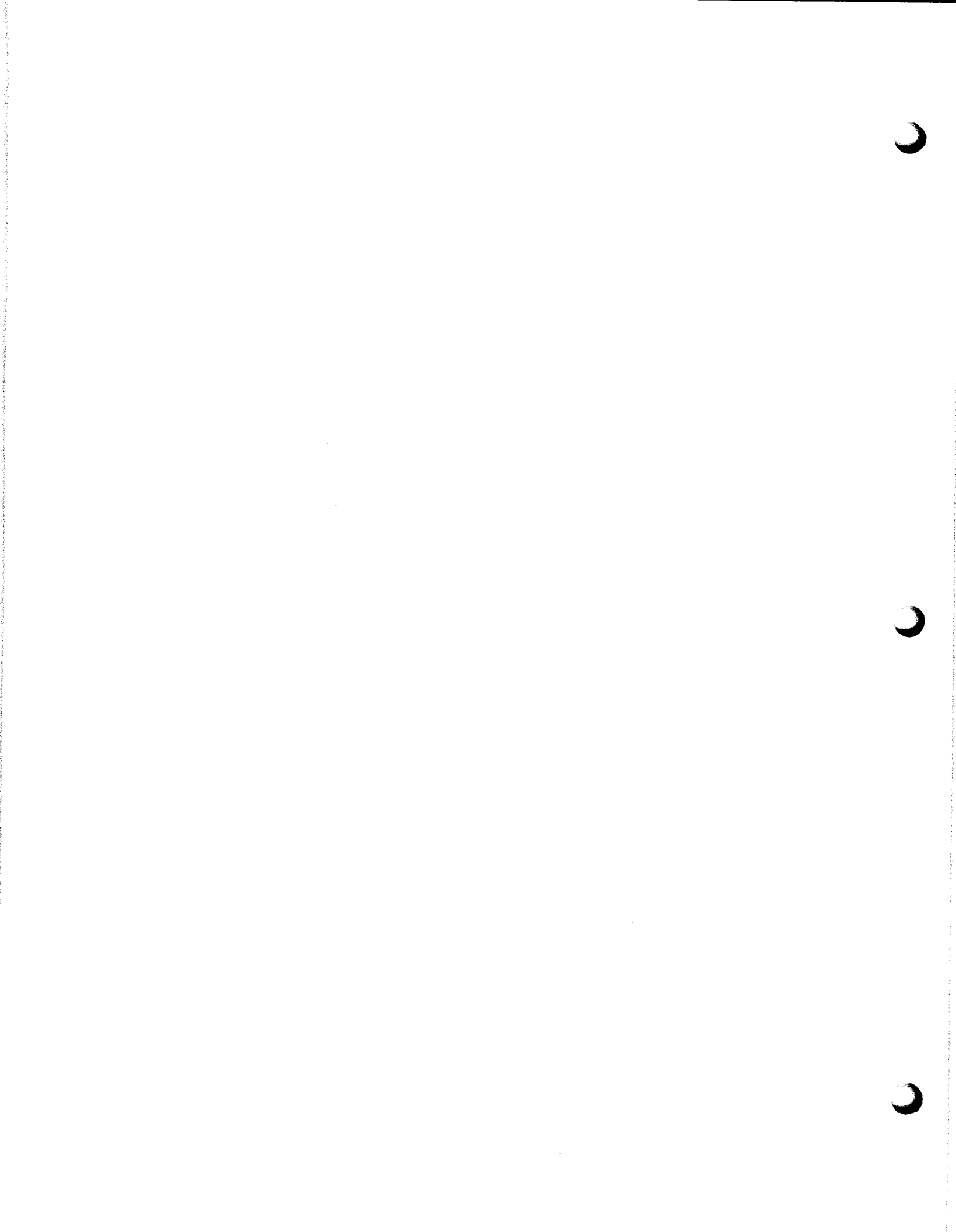

**SECTION 00510A – NOTICE OF AWARD**

**CONTRACTOR:** WRC1, LLC dba W. Rogers Company  
649 Bizzell Drive  
Lexington, Kentucky 40510

**OWNER:** Lexington-Fayette Urban County Government  
Division of Water Quality  
Lexington, Kentucky

**PROJECT: Expansion Area 3 Pump Station Improvements (Contract No. 1)**

Lexington-Fayette Urban County Government

LFUCG Bid No. [REDACTED]

You are hereby notified that the Owner has considered the Bid submitted by you for the above-described project in response to its Advertisement for Bids dated September 26, 2017.

It appears that it is to the best interest of said Owner to accept your Bid in the amount of Five Million One Hundred Ninety Thousand Seven Hundred Sixty Six dollars (\$5,190,766.00), and you are hereby notified that your Bid has been accepted for

Expansion Area 3 Pump Station Improvements (Contract No. 1)

LFUCG Bid No. [REDACTED]

The Contractor is required by these Contract Documents to execute and deliver the formal Agreement (Contract) with the undersigned Owner and to furnish the required Contractor's Performance, Payment, Warranty, and Erosion and Sediment Control Bonds within fifteen (15) days from the date of the delivery of this Notice.

If you fail to execute said Agreement (Contract) and to furnish said Bonds within fifteen (15) days from the date of delivery of this Notice, said Owner will be entitled to consider all your rights arising out of the Owner's acceptance of your Bid as abandoned and to award the Work covered by your Bid to another, or to re-advertise the Work or otherwise dispose thereof as the Owner may deem appropriate.

Dated this 15 day of NOVEMBER, 2017.

Lexington-Fayette Urban County Government

By: [Signature]

Title: PROJECT ENGINEERING COORDINATOR

**NOTICE OF ACCEPTANCE**

Receipt of the above Notice of Award is hereby acknowledged this 20<sup>th</sup> day of November, 2017

By: [Signature]

Title: President

END OF SECTION

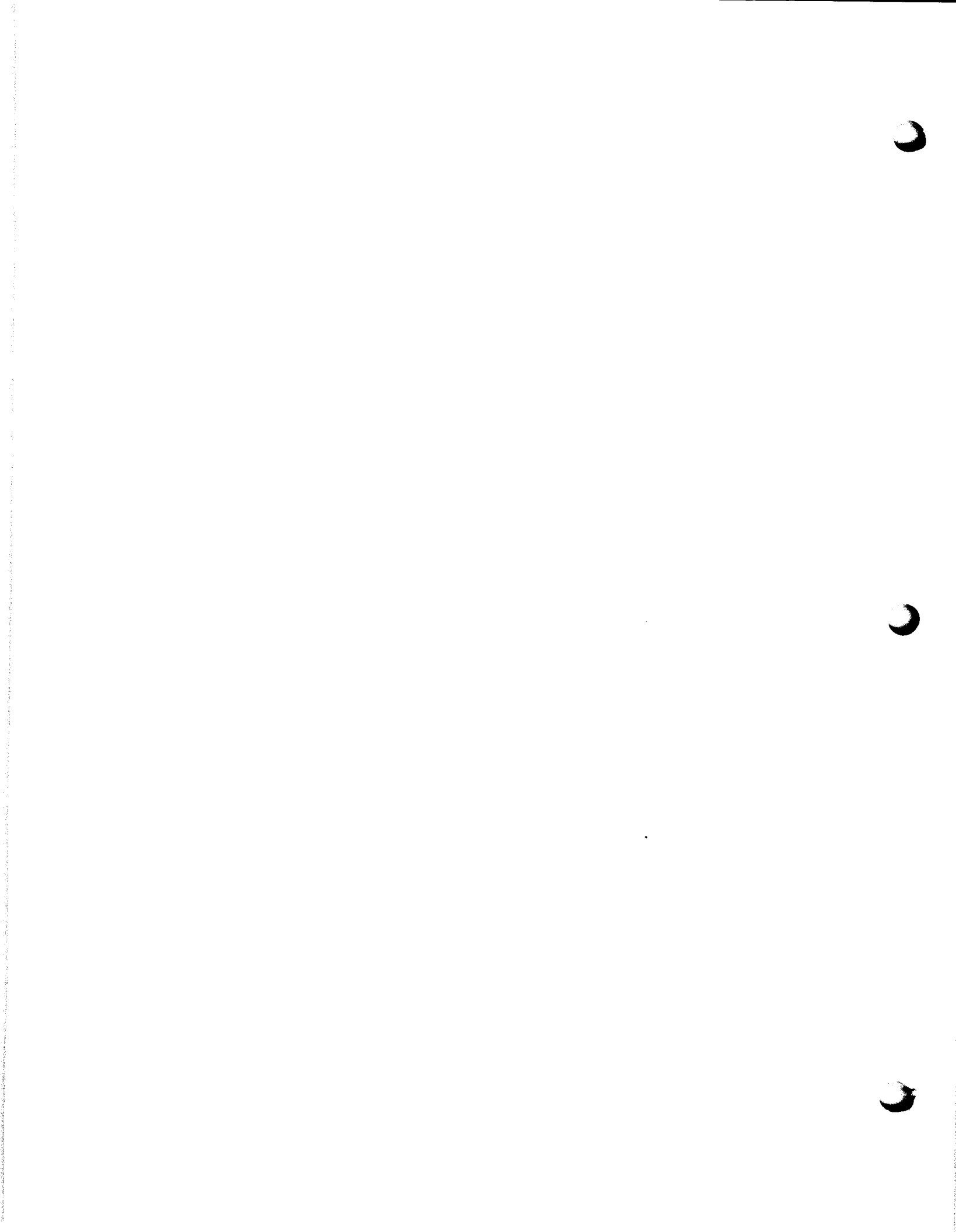

## SECTION 00520A – AGREEMENT (CONTRACT)

THIS AGREEMENT, made on the 9<sup>th</sup> day of November, 2017, by and between Lexington Fayette Urban County Government, acting herein called "OWNER" and WRC1, LLC dba W. Rogers Co. doing business as a Limited Liability Company located in the City of Lexington, County of Fayette, State of Kentucky, hereinafter called "CONTRACTOR".

WITNESSETH: That the CONTRACTOR and the OWNER in consideration of Five Million One Hundred Ninety Thousand Seven Hundred Sixty Six dollars (\$5,190,766.00) quoted in the BID by the CONTRACTOR, dated September 26, 2017, hereby agree to commence and complete the construction described as follows:

### 1.01 SCOPE OF WORK

The CONTRACTOR shall furnish all the materials, supplies, machinery, equipment, tools, supervision, labor, insurance, and other accessories and services necessary to complete the said project in accordance with the BID, the Contract Documents, and the Specifications prepared by the Engineer for the:

**Expansion Area 3 Pump Station Improvements (Contract No. 1)**  
LFUCG Bid No. 106-2017

### 1.02 TIME OF COMPLETION

The time period estimated and authorized by the OWNER for Substantial Completion of Work by the AGREEMENT, in full, is hereby fixed as ~~480~~ 450 (AD #4) **consecutive calendar days**. The time shall begin ten (10) calendar days after CONTRACTOR is issued the Notice to Proceed.

### 1.03 ISSUANCE OF NOTICE TO PROCEED

Notice to Proceed for Work will be issued in whole or in part of the Work as determined by the OWNER pending the availability of funds. The order of construction will be as determined by the Engineer after consultation with the CONTRACTOR and the OWNER.

### 1.04 AGREEMENT (CONTRACT) AMOUNT

The OWNER agrees to pay the CONTRACTOR in current funds for the performance of the AGREEMENT as quoted in the BID, subject to any additions and deductions, as provided therein.

### 1.05 PROGRESS PAYMENTS

The OWNER shall make payments on account of the AGREEMENT in accordance with the General Conditions, as recommended by the Engineer and authorized by the OWNER, less the aggregate of previous payments.

### 1.06 ACCEPTANCE AND FINAL PAYMENT

Final payment shall be due within ninety (90) days after Final Completion of the Work, provided the Work is deemed "Final Completion" and fully accepted by the OWNER.

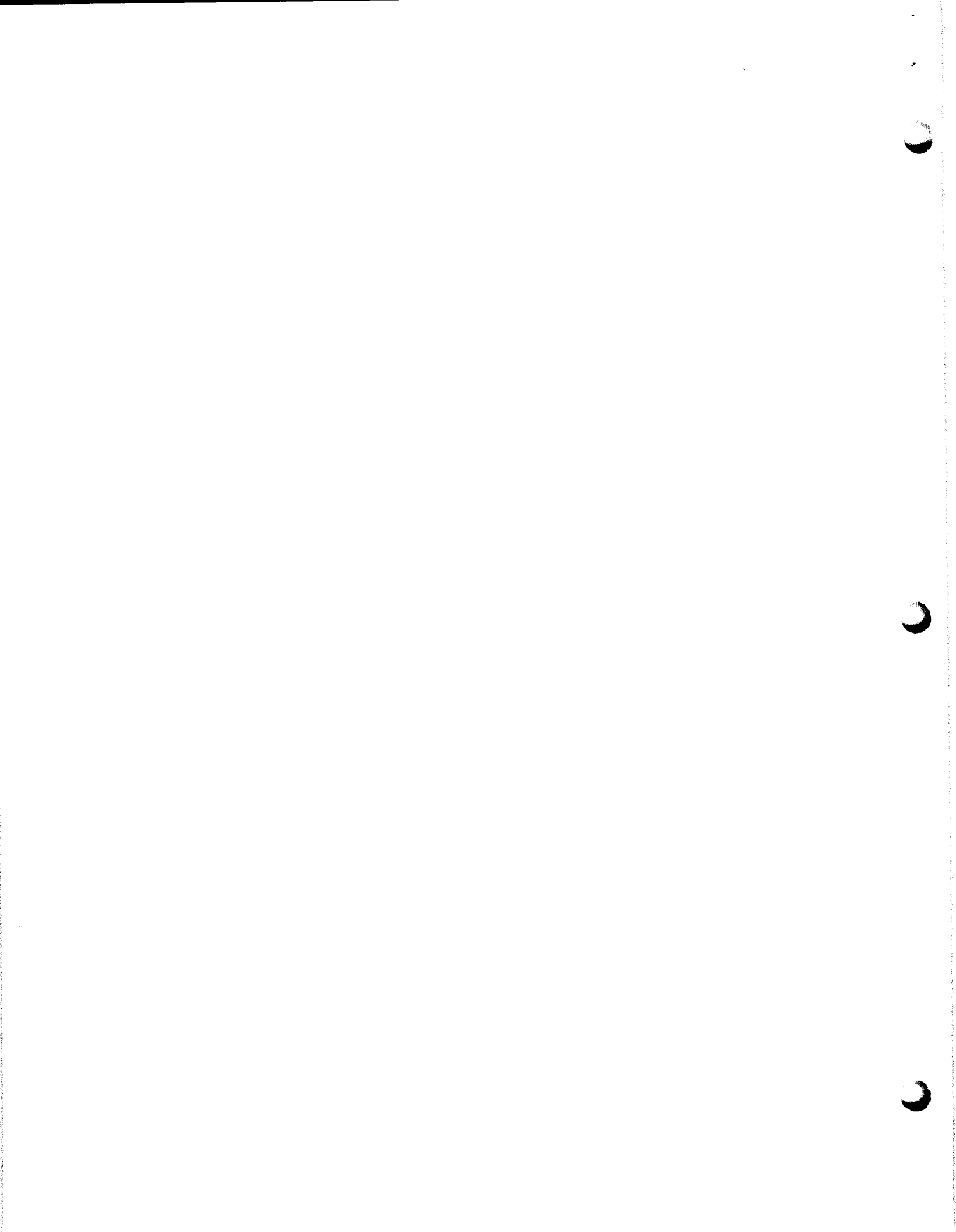



Before issuance of final certificate, the CONTRACTOR shall submit evidence satisfactory to the Engineer that all payrolls, material bills, and other indebtedness connected with the AGREEMENT (CONTRACT) has been paid.

If, after the Work has been substantially completed, full completion thereof is materially delayed through no fault of the CONTRACTOR, and the ENGINEER so certifies, the OWNER shall upon certificate of the ENGINEER, and without terminating the AGREEMENT (CONTRACT), make payment of the balance due for that portion of the Work fully completed and accepted. Such payment shall be made under the terms and conditions governing final payment, except that it shall not constitute a waiver of claims.

#### **1.07 EXTRA WORK**

The OWNER, without invalidating the AGREEMENT (CONTRACT) may order extra work or make changes by altering, adding to or deducting from the Work, the AGREEMENT (CONTRACT) amount being adjusted accordingly. All such work shall be executed and paid for in accordance with the General Conditions.

#### **1.08 LIQUIDATED DAMAGES**

If the CONTRACTOR shall fail or refuse to complete the Work within the AGREEMENT (CONTRACT) Time, or extension of time granted by the OWNER, then the CONTRACTOR agrees as a partial consideration for the awarding of this AGREEMENT (CONTRACT) that the OWNER may retain the compensation otherwise to be paid to the CONTRACTOR the amount of eight hundred dollars (\$800) per consecutive calendar day that the CONTRACTOR shall be in default after the Final Completion time stipulated in the Contract Documents. The said amount is fixed and agreed upon by and between the CONTRACTOR and the OWNER because of the impracticability and extreme difficulty of fixing and ascertaining the actual damages the OWNER would in such event sustain.

#### **1.09 CONSENT DECREE REQUIREMENTS**

- A. The OWNER, the United States Environmental Protection Agency, and the Commonwealth of Kentucky have entered into a Consent Decree in a case styled *United States, et al. v. Lexington-Fayette Urban County Government*, United States District Court for the Eastern District of Kentucky, Case No. 5:06-CV-00386 ("CONSENT DECREE"), that requires OWNER to complete numerous projects related to its sanitary sewer system and stormwater management program within specific periods of time.
- B. **Time is of the essence in the performance of this Agreement (CONTRACT).** CONTRACTOR is aware that the OWNER is subject to penalties for non-compliance with the CONSENT DECREE deadlines. The CONTRACTOR shall be specifically liable and responsible for payment of any and all penalties, fines, or fees assessed against or incurred by the OWNER as a result of any delay in, or non-performance of, any of the CONTRACTOR's obligations or responsibilities under this AGREEMENT (CONTRACT), or for any other damages suffered by OWNER as a result of such delay or non-performance. This shall specifically include, but shall not be limited to, any penalty, fine, fee, or assessment against the OWNER by the U.S. Department of Justice, U.S. Environmental Protection Agency, and/or the Kentucky Energy and Environment Cabinet related to the CONSENT DECREE.
- C. The provisions of the Contract Documents and the various rates of compensation for CONTRACTOR's services provided for elsewhere in this AGREEMENT (CONTRACT) have been agreed to in anticipation of the orderly and continuous progress of the AGREEMENT (CONTRACT) through completion.

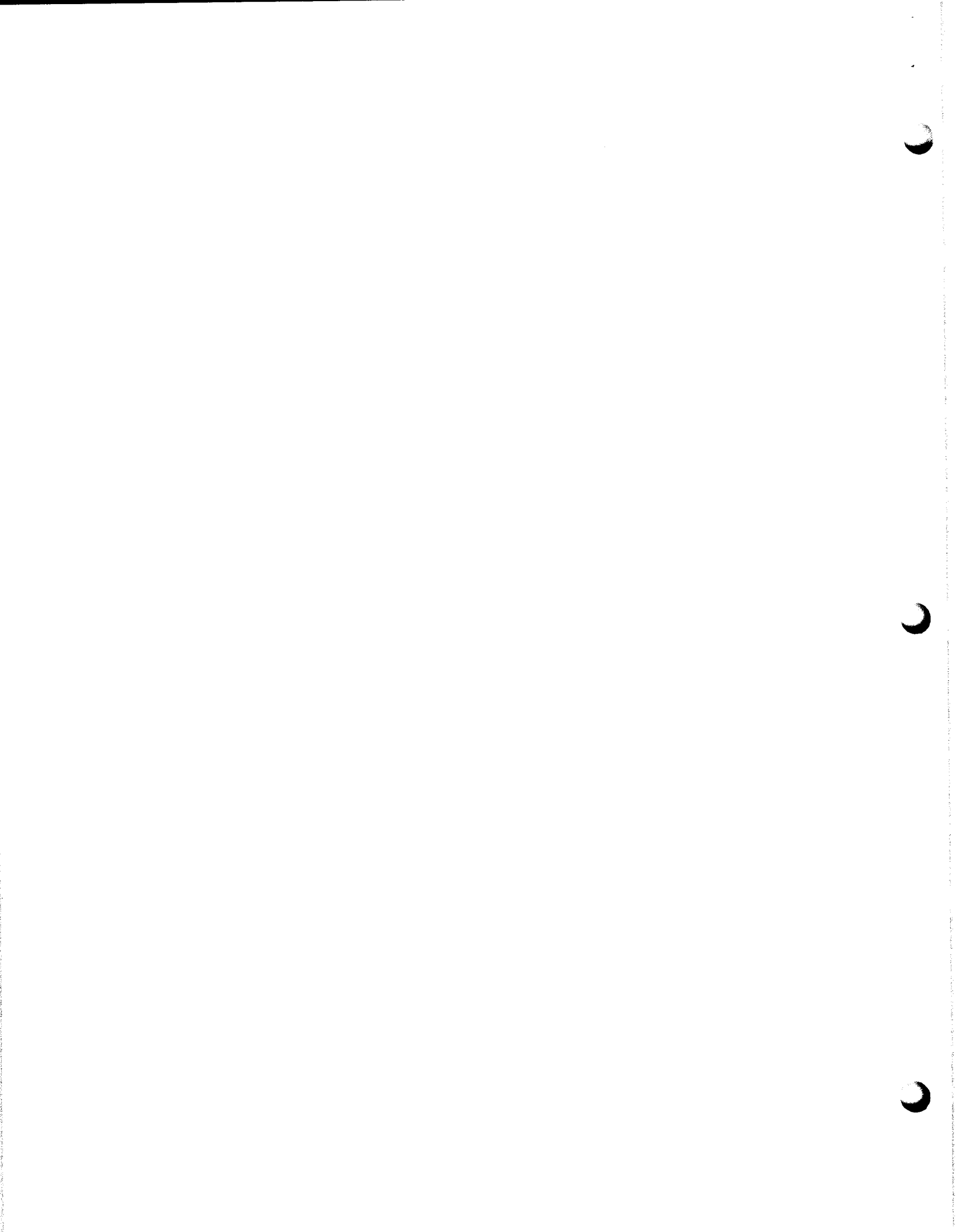

- D. If delays result by reason of acts of the OWNER or approving agencies, which are beyond the control of the CONTRACTOR, an extension of time for such delay will be considered. If delays occur, the CONTRACTOR shall immediately notify the OWNER and within five (5) business days from the date of the delay apply in writing to the OWNER for an extension of time for such reasonable period as may be mutually agreed upon between the parties, and if approved, the AGREEMENT (CONTRACT) schedule shall be revised to reflect the extension. Such extension of time to the completion date shall in no way be construed to operate as a waiver on the part of the OWNER of any of its rights in the AGREEMENT (CONTRACT). In the event the parties cannot agree upon an extension of time, the Dispute shall be addressed in the manner outlined hereinafter under this Article.

In the event that the overall delay resulting from the above-described causes is sufficient to prevent complete performance of the AGREEMENT (CONTRACT) within six (6) months of the time specified herein, the fees to be paid to CONTRACTOR shall be subject to adjustment as agreed upon by the parties.

- E. If delays result solely by reason of acts of the CONTRACTOR, the CONTRACTOR shall be held liable for any financial penalties incurred by the OWNER as a result of the delay, including but not limited to those assessed pursuant to the CONSENT DECREE. Disputes as outlined hereinafter in this Article shall apply in the event the parties cannot mutually agree upon the cause(s) associated with delays in completing project deliverables. The CONTRACTOR must immediately notify the OWNER in the event of such delay, and provide the OWNER a written action plan within five (5) business days on how it will attempt to resolve the delay.

F. DISPUTES

Except as otherwise provided in this AGREEMENT (CONTRACT), any dispute hereunder may be resolved by agreement of the OWNER's Agent (Charles H. Martin, P.E., Director of Water Quality) and the CONTRACTOR. In the absence of such an agreement, the dispute shall be submitted to the OWNER's Commissioner, Department of Public Works and Environmental Quality, whose decision shall be final and conclusive unless determined by a court of competent jurisdiction to have been fraudulent, capricious, arbitrary, or so grossly erroneous as necessarily to imply bad faith. Pending a final decision of a dispute hereunder the CONTRACTOR shall proceed diligently with the performance of the AGREEMENT (CONTRACT) in accordance with the direction of the OWNER.

**1.10 RIGHT TO REVIEW, AUDIT, AND INSPECT**

The CONTRACTOR shall provide to the OWNER or its duly authorized representative(s), at any time during the course of the contract and up to five (5) years thereafter, access to any books, documents, papers, emails, and/or other records or communications which are directly pertinent to this specific contract for the purpose of making audit, examination, excerpts, and transcriptions.

**1.11 CONTRACT DOCUMENTS**

In general, the Advertisement for Bids, Information Available to Bidders, the Bid, the General Conditions, Performance, Payment, Erosion and Sediment Control and Warranty Bonds, AGREEMENT (CONTRACT), Supplementary Conditions, Supplemental General Conditions for SRF, Technical Specifications, any and all Addenda, and Plan Drawings form the AGREEMENT (CONTRACT) and they are fully a part of the AGREEMENT (CONTRACT) as if hereto attached or herein repeated.

A full listing of the Contract Documents consist of the following:



Specifications: Per Table of Contents  
Drawings (Plans): Per Table of Contents

IN WITNESSETH WHEREOF, the parties hereto have executed this AGREEMENT (CONTRACT) as of the date and year above written.

(Seal)

Lexington-Fayette Urban County Government  
Lexington, Kentucky

(Owner)

ATTEST:

  
Clerk of Urban County Council

By: \_\_\_\_\_

  
(Signature of Mayor)

\_\_\_\_\_, Mayor

(Name/Title)

(Seal)

WRC1, LLC dba W. Rogers Co.  
(Contractor)

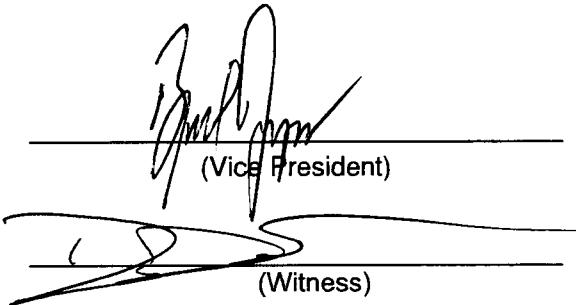
  
(Vice President)

  
(Witness)

By: \_\_\_\_\_

  
(Contractor's Signature)

Warren P. Rogers, President  
(Name/Title)

649 Bizzell Drive, Lexington, KY 40510-1004  
(Address)

\*IMPORTANT: Strike out any non-applicable terms:

Secretary of the OWNER should attest. If the CONTRACTOR is corporation, Secretary should attest. Give proper title of each person-executing AGREEMENT (CONTRACT).

END OF SECTION

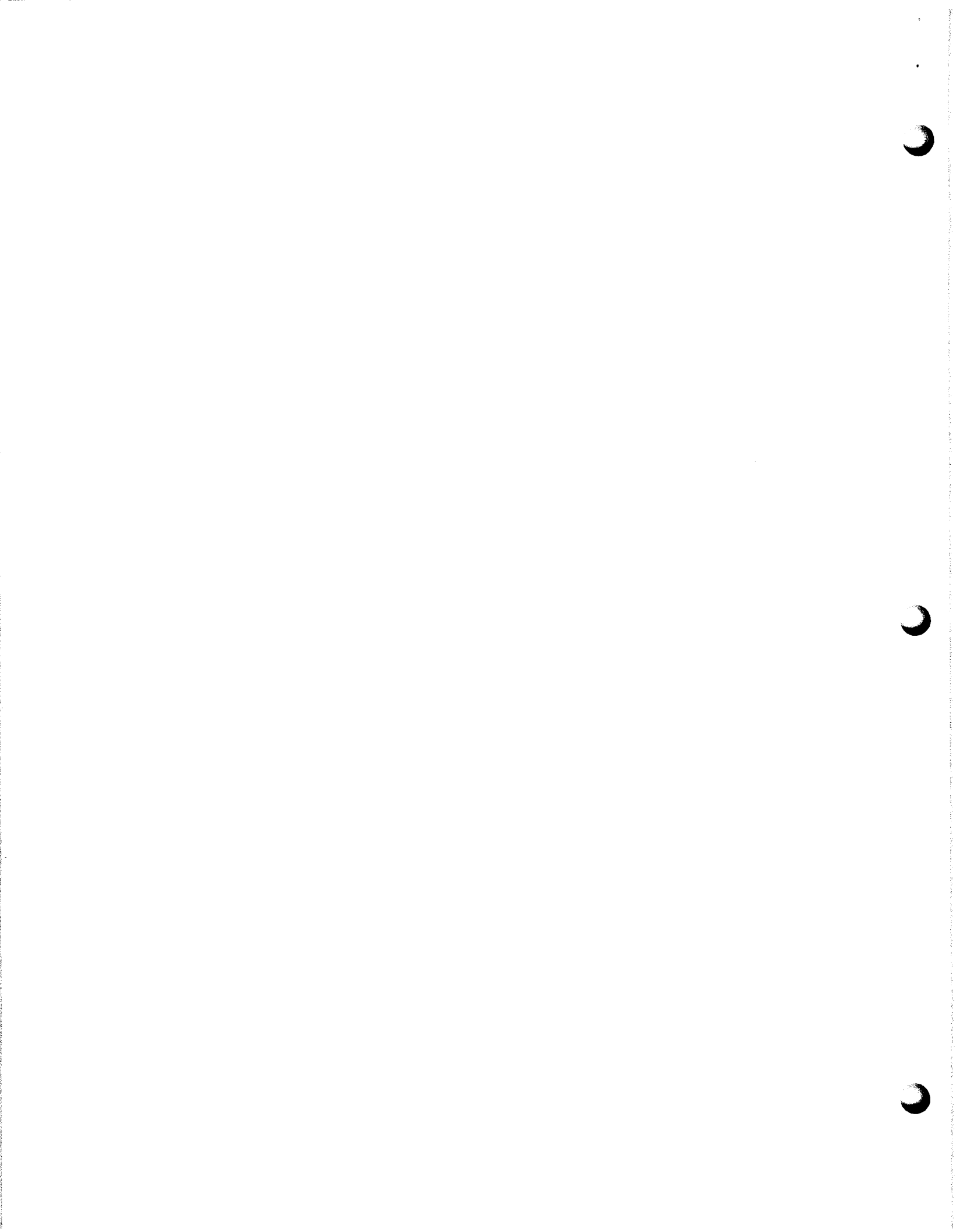

**SECTION 00550A – NOTICE TO PROCEED**

CONTRACTOR: WRC1, LLC dba W. Rogers Company  
649 Bizzell Drive  
Lexington, Kentucky 40510

OWNER: Lexington-Fayette Urban County Government  
Lexington, Kentucky

PROJECT: Expansion Area 3 Pump Station Improvements (Contract No. 1)  
Lexington-Fayette Urban County Government  
Lexington, Kentucky

LFUCG Bid No. [REDACTED]

Agreement (Contract) Amount:  
Five Million One Hundred Ninety Thousand Seven Hundred Sixty Six dollars  
(\$ 5,190,766.00)

You are hereby notified to commence Work on the referenced project on or before \_\_\_\_\_, 2017 and to substantially complete Work within ~~480~~ 450 (AD #4) CONSECUTIVE CALENDAR DAYS thereafter. Your Agreement (Contract) completion date is therefore \_\_\_\_\_, 2017.

The Agreement (Contract) provides for assessment of the sum of Eight Hundred dollars (\$800) as liquidated damages for each consecutive calendar day after the above established Agreement (Contract) completion date that the Work remains incomplete.

Lexington-Fayette Urban County Government

By: \_\_\_\_\_

Title: \_\_\_\_\_

Date: \_\_\_\_\_

END OF SECTION

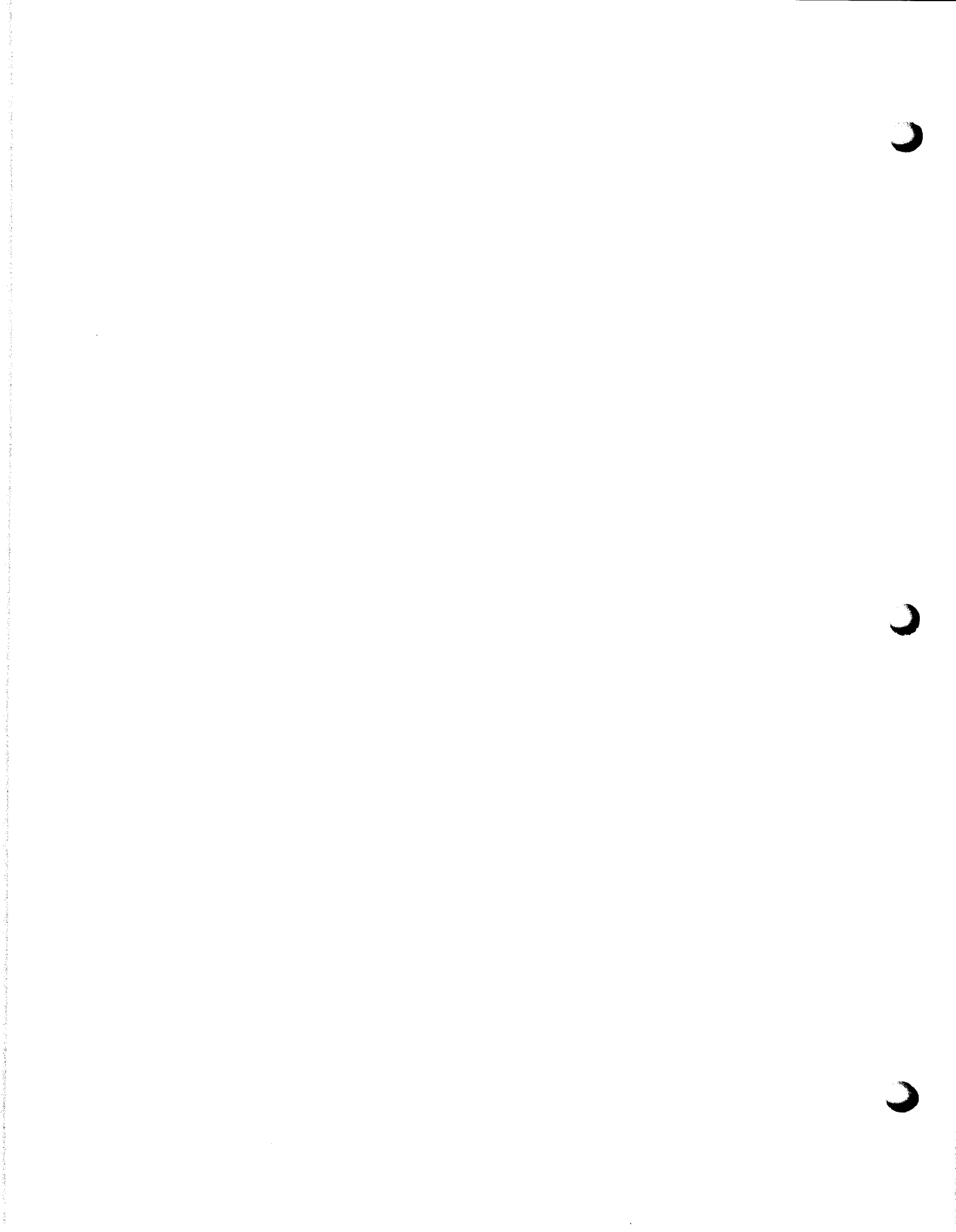



PERFORMANCE BOND

KNOW ALL MEN BY THESE PRESENTS, that

WRC1, LLC dba W. Rogers Company  
649 Bizzell Drive  
Lexington, Kentucky 40510

a Limited Liability Company, hereinafter called Principal, and  
Travelers Casualty and Surety Company of America  
Hartford, CT

hereinto called Surety, are held and firmly bound unto

LEXINGTON-FAYETTE URBAN COUNTY GOVERNMENT  
200 East Main Street, Third Floor  
Lexington, Kentucky 40507

Obligee, hereinafter called "OWNER" in the penal sum of:

Five Million One Hundred Ninety Thousand Seven Hundred Sixty Six dollars (\$5,190,766.00), for the payment of whereof Principal and Surety bind themselves, their heirs, executors, administrators, successors, and assigns, jointly and severally, firmly by these presents.

WHEREAS, Principal by written agreement is entering into an Agreement (Contract) with OWNER for the Expansion Area 3 Pump Station Improvements, LFUCG Bid No. 106-2017 in accordance with Contract Documents prepared by HDR Engineering, Inc. and dated November 21, 2017, which Agreement (Contract) is by reference made a part hereof, and is hereinafter referred to as the Agreement (Contract).

NOW THEREFORE, THE CONDITION OF THIS OBLIGATION is such that if the Principal shall promptly and faithfully perform said Agreement (Contract), then this obligation shall be null and void; otherwise it shall remain in full force and effect.

The Surety hereby waives notice of any alteration or extension of time made by the OWNER.

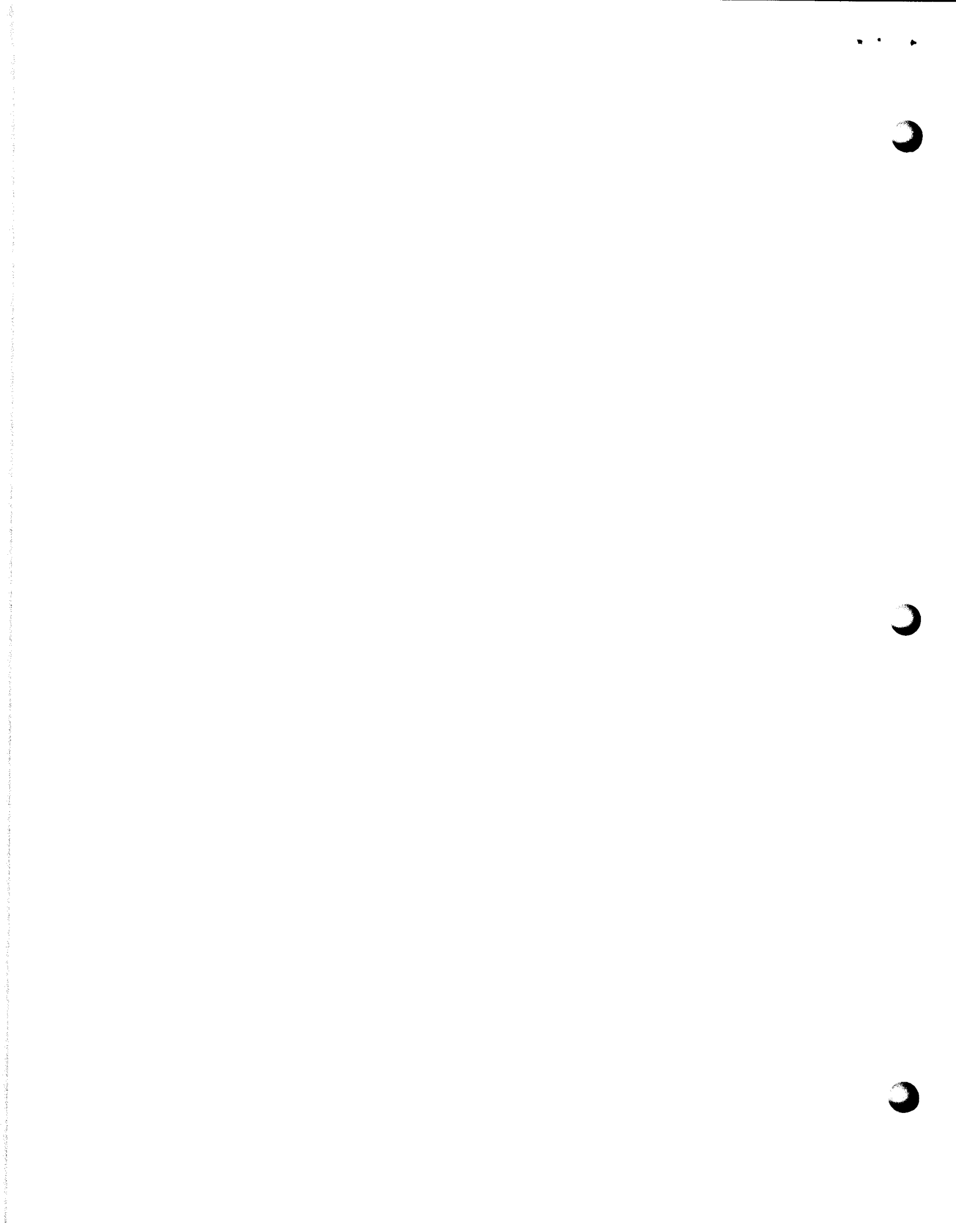

Whenever, Principal shall be, and declared by OWNER to be in default under the Agreement (Contract), the OWNER having performed OWNER'S obligations thereunder, the Surety may promptly remedy the default, or shall promptly:

1. Complete the Agreement (Contract) in accordance with its terms and conditions or
2. Obtain a Bid or Bids for completing the Agreement (Contract) in accordance with its terms and conditions, and upon determination by Surety of the lowest responsible bidder, or if the OWNER elects, upon determination by the OWNER and Surety jointly of the lowest responsible bidder; arrange for an Agreement (Contract) between such bidder and OWNER, and make available as Work progresses (even though there may be a default or a succession of defaults under the Agreement (Contract) or Agreements (Contracts) of completion arranged under this paragraph) sufficient funds to pay the cost of completion less the balance of the Agreement (Contract) Amount; but not exceeding, including other costs and damages for which the Surety may be liable hereunder, the amount set forth in the first paragraph hereof. The term "Balance of the Agreement (Contract) Amount", as used in this paragraph shall mean the total amount payable by OWNER to Principal under the Agreement (Contract) and any amendments thereto, less the amount properly paid by OWNER to Principal.

Any suit under this bond must be instituted before the expiration of one (1) year from the date on which final payment under the Contract falls due.

No right of action shall accrue on this bond to or for the use of any person or corporation other than the OWNER named herein or the heirs, executors, administrators or successors of OWNER.

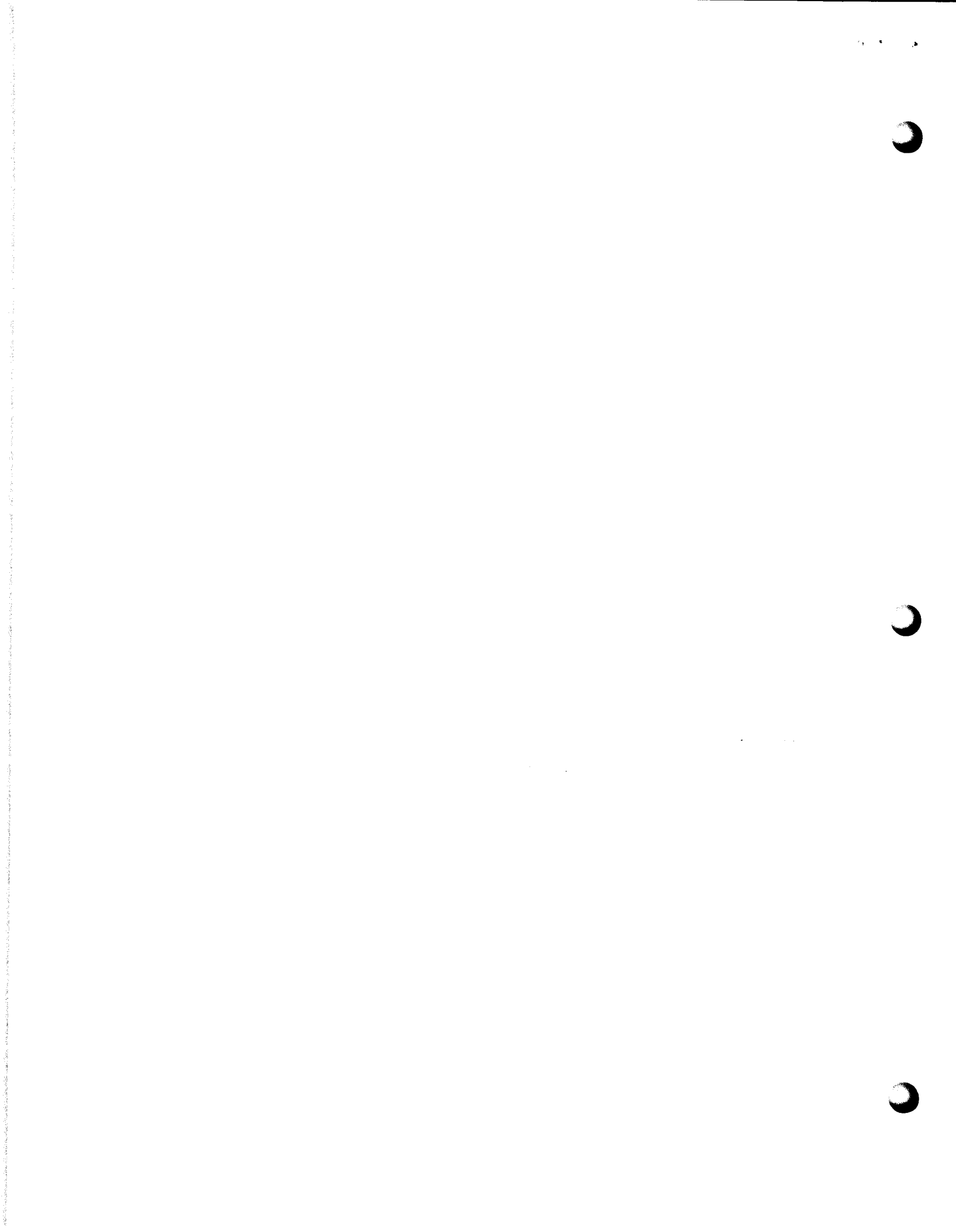

IN WITNESS WHEREOF, this instrument is executed in 5 counterparts, each one of

which shall be deemed an original, this the 21st day of November, 2017.

ATTEST:

WRC1, LLC dba W. Rogers Company  
Principal

X  
\_\_\_\_\_  
(Principal) Secretary

By: X W. Rogers (s)

649 Bizzell Drive  
Address

Lexington, Kentucky 40510

X  
\_\_\_\_\_  
Witness as to Principal

X  
\_\_\_\_\_  
Address

X  
\_\_\_\_\_

Travelers Casualty and Surety Co. of America  
Surety

By: A. Tierney  
Attorney-in-Fact A. Tierney

One Tower Square  
Address

Hartford, Connecticut 06183

ATTEST:

Paulette M. Aerni  
(Surety) Secretary  
Paulette M. Aerni

(SEAL)

Linda L. Hogle, Witness  
Witness to Surety

312 Elm Street, 24th Floor  
Address

Cincinnati, Ohio 45202

Title: Richard A. Davis, Witness  
Surety

By: Richard A. Davis

Title: Linda L. Hogle

NOTE: The number of executed counterparts of the bond shall coincide with the number of executed counterparts of the Agreement (Contract).

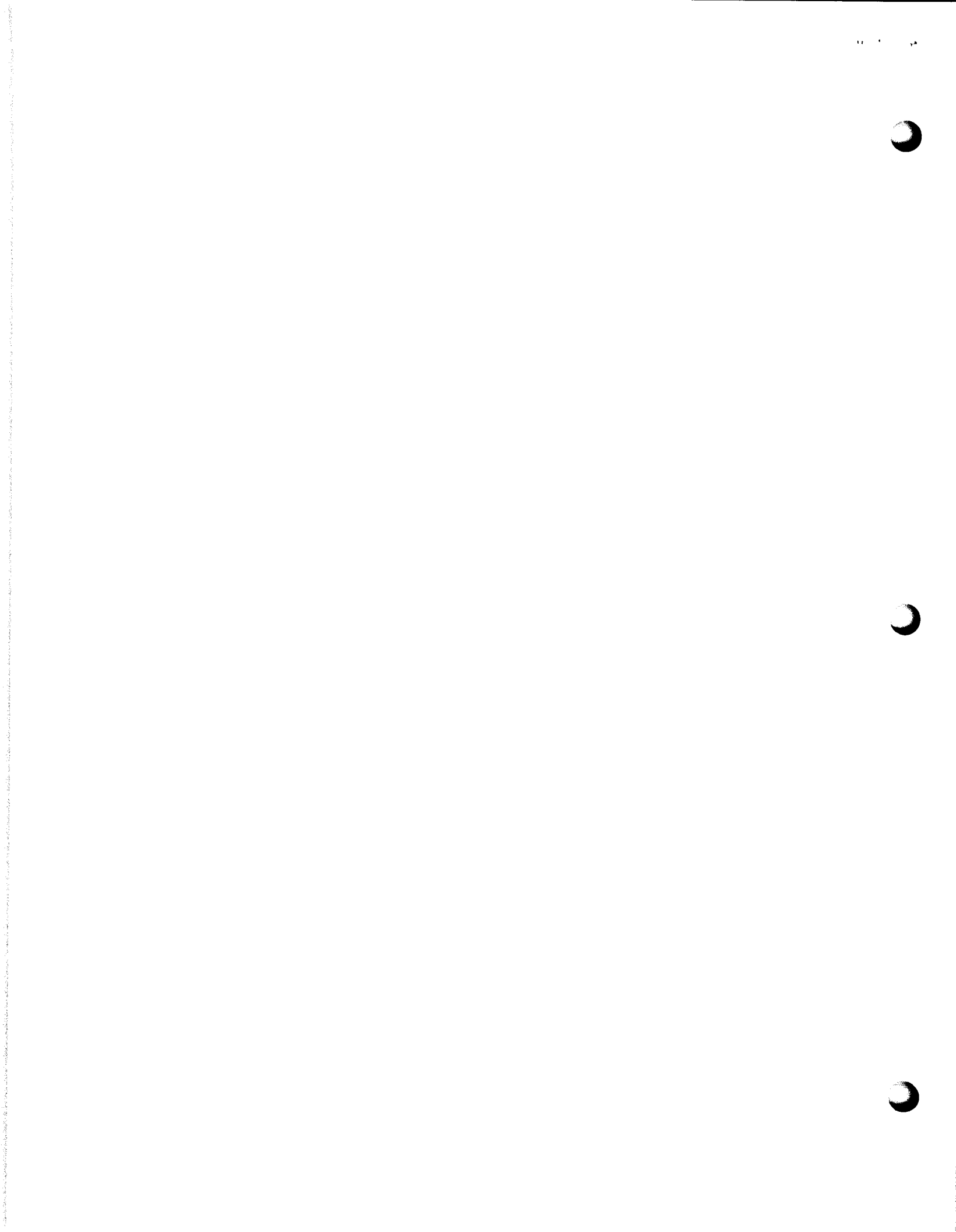

PAYMENT BOND

KNOW ALL MEN BY THESE PRESENTS, that

WRC1, LLC dba W. Rogers Company  
649 Bizzell Drive  
Lexington, Kentucky 40510

a Limited Liability Company, hereinafter called Principal, and  
Travelers Casualty and Surety Company of America  
Hartford, CT

hereinto called Surety, are held and firmly bound unto

LEXINGTON-FAYETTE URBAN COUNTY GOVERNMENT  
200 East Main Street, Third Floor  
Lexington, Kentucky 40507

Obligee, hereinafter called "OWNER" in the penal sum of:

Five Million One Hundred Ninety Thousand Seven Hundred Sixty Six dollars (\$5,190,766.00), for the payment of whereof Principal and Surety bind themselves, their heirs, executors, administrators, successors, and assigns, jointly and severally, firmly by these presents.

WHEREAS, Principal by written agreement is entering into an Agreement (Contract) with OWNER for the Expansion Area 3 Pump Station Improvements, LFUCG Bid No. 106-2017 in accordance with Contract Documents prepared by HDR Engineering, Inc. and dated November 21, 2017, which Agreement (Contract) is by reference made a part hereof, and is hereinafter referred to as the Agreement (Contract).

NOW, THEREFORE THE CONDITION OF THIS OBLIGATION is such that, if Principal shall promptly make payment to all claimants as hereinafter defined for all labor and material used or reasonably required for use in the performance of the Agreement (Contract), then this obligation shall be void; otherwise it shall remain in full force and effect, subject, however, to the following conditions:

1. A claimant is defined as one having a direct contract with the Principal or with a Subcontractor of the Principal for labor material, or both, used or reasonably required for use in the performance of the Agreement (Contract), labor and material being construed to include that part of water, gas, power, light, heat, oil, gasoline, telephone service or rental of equipment directly applicable to the Agreement (Contract).
2. The above named Principal and Surety hereby jointly and severally agree with the OWNER that every claimant as herein defined, who has not been paid in full before the expiration of a period of ninety (90) days after the date on which the last of such claimant's work or labor was done or performed, or materials were furnished by such claimant, may sue on this bond for the use of such claimant, prosecute the suit to final judgment for such sum or sums as may be justly due claimant and have execution thereon. The OWNER shall not be liable for the payment of any costs or expenses of any such suit.
3. No suit or action shall be commenced hereunder by any claimant:

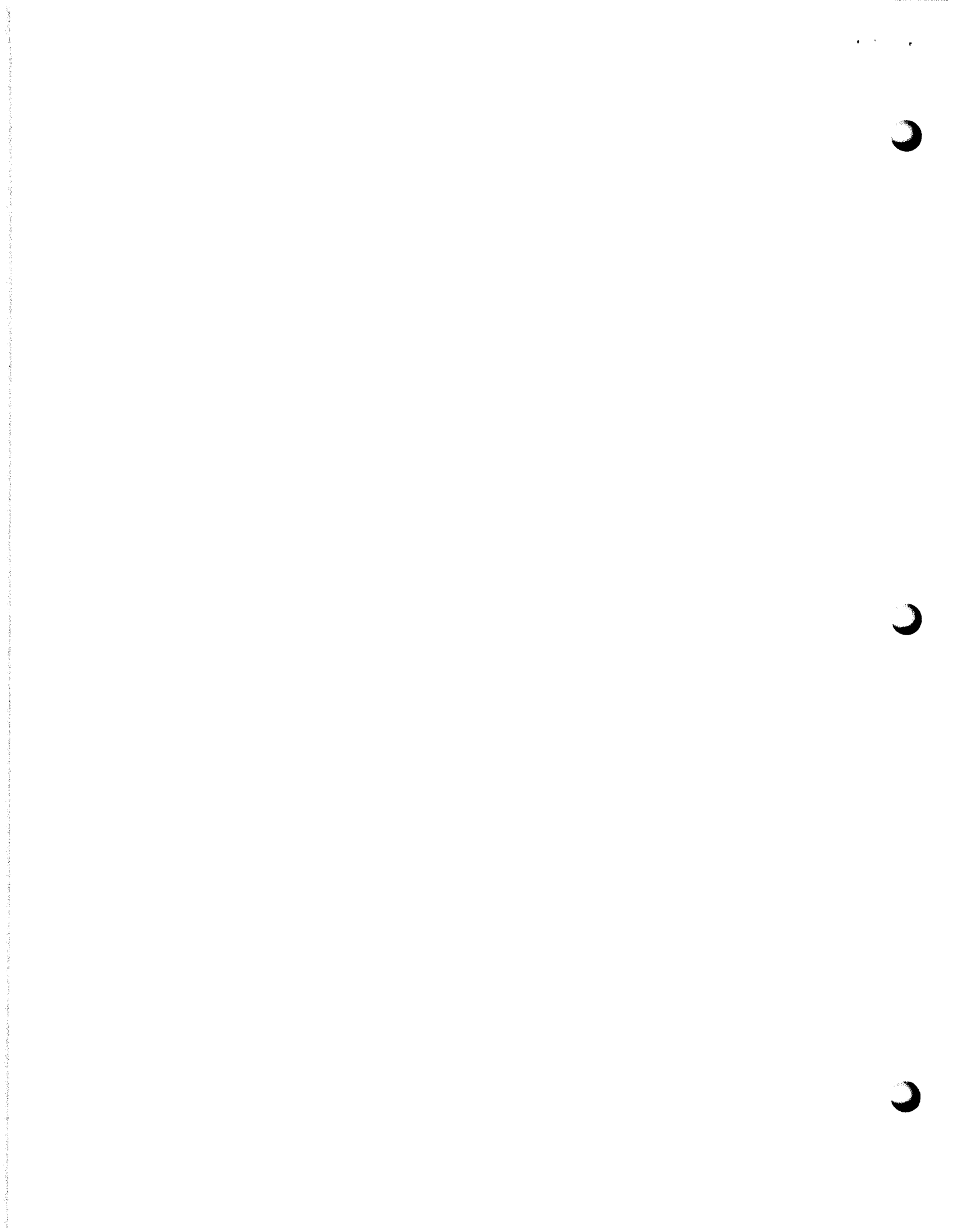



- (a) Unless claimant, other than one having a direct contract with the Principal, shall have given written notice to any two of the following: The Principal, the OWNER, or the Surety above named, within ninety (90) days after such claimant did or performed the last of the Work or labor, or furnished the last of the materials for which said claim is made, stating with substantial accuracy the amount claimed and the name of the party to whom the materials were furnished, or for whom the Work or labor was done or performed. Such notice shall be served by mailing the same by registered mail or certified mail, postage prepaid, in an envelope addressed to the Principal, OWNER, or Surety, at any place where an office is regularly maintained for the transaction of business, or served in any manner in which legal process may be served in the state in which the aforesaid project is located, save that such service need not be made by a public officer.
- (b) After the expiration of one (1) year following the date on which Principal ceased Work on said Agreement (Contract), it being understood, however, that if any limitation embodied in this bond is prohibited by any law controlling the construction hereof such limitation shall be deemed to be amended so as to be equal to the minimum period of limitation permitted by such law.
- (c) Other than in a state court of competent jurisdiction in and for the county or other political subdivision of the state in which the project, or any part thereof, is situated, or in the United States District Court for the district in which the project, or any part thereof, is situated, and not elsewhere.
4. The amount of this bond shall be reduced by and to the extent of any payment or payments made in good faith hereunder, inclusive of the payment by Surety of mechanics' liens which may be filed of record against said improvement, whether or not claim for the amount of such lien be presented under and against this bond.



IN WITNESS WHEREOF, this instrument is executed in 5 counterparts, each one of which shall be deemed an original, this the 21st day of November, 2017.

ATTEST:

WRC1, LLC dba W. Rogers Company  
Principal

X  
\_\_\_\_\_  
(Principal) Secretary

By: X W. Rogers (s)

649 Bizzell Drive  
Address

Lexington, Kentucky 40510

X [Signature]  
\_\_\_\_\_  
Witness as to Principal

X 649 Bizzell Drive  
Address

X Lexington Ky 40510

Travelers Casualty and Surety Co. of America  
Surety

By: Anne Tierney  
Attorney-in-Fact Anne Tierney

One Tower Square  
Address

Hartford, Connecticut 06183

ATTEST:

[Signature]  
\_\_\_\_\_  
(Surety) Secretary  
Paulette M. Aerni

(SEAL)

Linda L. Hogle, Witness  
\_\_\_\_\_  
Witness to Surety

312 Elm Street, 24th Floor  
Address

Cincinnati, Ohio 45202

Title: Linda L Hogle

Title: Richard A. Davis, Witness  
\_\_\_\_\_  
Surety

By: [Signature]

NOTE: The number of executed counterparts of the bond shall coincide with the number of executed counterparts of the Agreement (Contract).

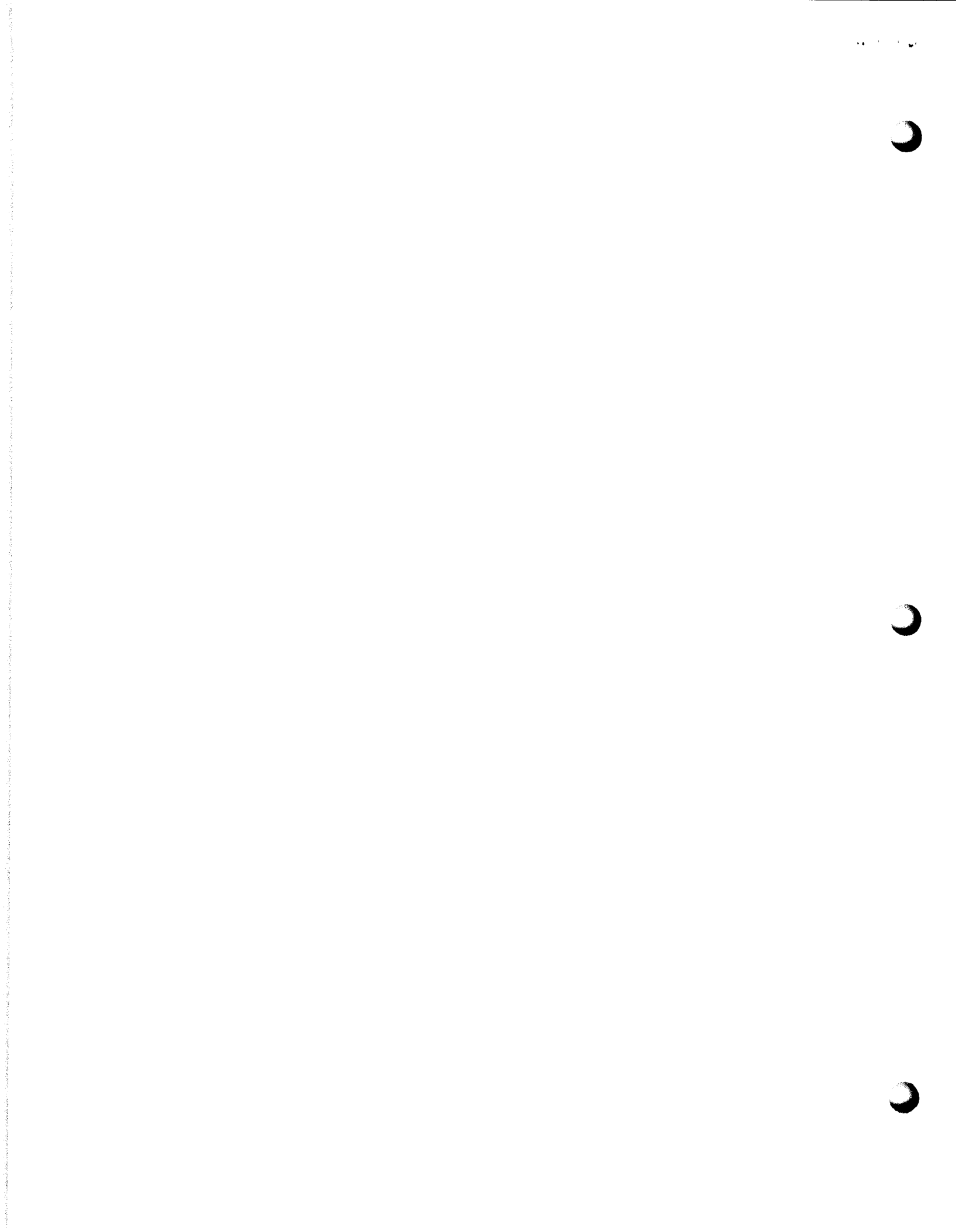



POWER OF ATTORNEY

Farmington Casualty Company
Fidelity and Guaranty Insurance Company
Fidelity and Guaranty Insurance Underwriters, Inc.
St. Paul Fire and Marine Insurance Company
St. Paul Guardian Insurance Company

St. Paul Mercury Insurance Company
Travelers Casualty and Surety Company
Travelers Casualty and Surety Company of America
United States Fidelity and Guaranty Company

Attorney-In Fact No. 224743

Certificate No. 007326181

KNOW ALL MEN BY THESE PRESENTS: That Farmington Casualty Company, St. Paul Fire and Marine Insurance Company, St. Paul Guardian Insurance Company, St. Paul Mercury Insurance Company, Travelers Casualty and Surety Company, Travelers Casualty and Surety Company of America, and United States Fidelity and Guaranty Company are corporations duly organized under the laws of the State of Connecticut, that Fidelity and Guaranty Insurance Company is a corporation duly organized under the laws of the State of Iowa, and that Fidelity and Guaranty Insurance Underwriters, Inc., is a corporation duly organized under the laws of the State of Wisconsin (herein collectively called the "Companies"). and that the Companies do hereby make, constitute and appoint

Thomas W. Chatham, Richard A. Davis, Paulette M. Aerni, Thomas D. Cassady, Anne Tierney, Linda L. Hogle, and Paul J. Schueler Jr.

of the City of Cincinnati, State of Ohio, their true and lawful Attorney(s)-in-Fact, each in their separate capacity if more than one is named above, to sign, execute, seal and acknowledge any and all bonds, recognizances, conditional undertakings and other writings obligatory in the nature thereof on behalf of the Companies in their business of guaranteeing the fidelity of persons, guaranteeing the performance of contracts and executing or guaranteeing bonds and undertakings required or permitted in any actions or proceedings allowed by law.

WITNESS WHEREOF, the Companies have caused this instrument to be signed and their corporate seals to be hereto affixed, this 8th day of August, 2017.

Farmington Casualty Company
Fidelity and Guaranty Insurance Company
Fidelity and Guaranty Insurance Underwriters, Inc.
St. Paul Fire and Marine Insurance Company
St. Paul Guardian Insurance Company

St. Paul Mercury Insurance Company
Travelers Casualty and Surety Company
Travelers Casualty and Surety Company of America
United States Fidelity and Guaranty Company



State of Connecticut
City of Hartford ss.

By: [Signature]
Robert L. Raney, Senior Vice President

On this the 8th day of August, 2017, before me personally appeared Robert L. Raney, who acknowledged himself to be the Senior Vice President of Farmington Casualty Company, Fidelity and Guaranty Insurance Company, Fidelity and Guaranty Insurance Underwriters, Inc., St. Paul Fire and Marine Insurance Company, St. Paul Guardian Insurance Company, St. Paul Mercury Insurance Company, Travelers Casualty and Surety Company, Travelers Casualty and Surety Company of America, and United States Fidelity and Guaranty Company, and that he, as such, being authorized so to do, executed the foregoing instrument for the purposes therein contained by signing on behalf of the corporations by himself as a duly authorized officer.

Witness Whereof, I hereunto set my hand and official seal.
My Commission expires the 30th day of June, 2021.



[Signature]
Marie C. Tetreault, Notary Public

This Power of Attorney is granted under and by the authority of the following resolutions adopted by the Boards of Directors of Farmington Casualty Company, Fidelity and Guaranty Insurance Company, Fidelity and Guaranty Insurance Underwriters, Inc., St. Paul Fire and Marine Insurance Company, St. Paul Guardian Insurance Company, St. Paul Mercury Insurance Company, Travelers Casualty and Surety Company, Travelers Casualty and Surety Company of America, and United States Fidelity and Guaranty Company, which resolutions are now in full force and effect, reading as follows:

**RESOLVED**, that the Chairman, the President, any Vice Chairman, any Executive Vice President, any Senior Vice President, any Vice President, any Second Vice President, the Treasurer, any Assistant Treasurer, the Corporate Secretary or any Assistant Secretary may appoint Attorneys-in-Fact and Agents to act for and on behalf of the Company and may give such appointee such authority as his or her certificate of authority may prescribe to sign with the Company's name and seal with the Company's seal bonds, recognizances, contracts of indemnity, and other writings obligatory in the nature of a bond, recognizance, or conditional undertaking, and any of said officers or the Board of Directors at any time may remove any such appointee and revoke the power given him or her; and it is

**FURTHER RESOLVED**, that the Chairman, the President, any Vice Chairman, any Executive Vice President, any Senior Vice President or any Vice President may delegate all or any part of the foregoing authority to one or more officers or employees of this Company, provided that each such delegation is in writing and a copy thereof is filed in the office of the Secretary; and it is

**FURTHER RESOLVED**, that any bond, recognizance, contract of indemnity, or writing obligatory in the nature of a bond, recognizance, or conditional undertaking shall be valid and binding upon the Company when (a) signed by the President, any Vice Chairman, any Executive Vice President, any Senior Vice President or any Vice President, any Second Vice President, the Treasurer, any Assistant Treasurer, the Corporate Secretary or any Assistant Secretary and duly attested and sealed with the Company's seal by a Secretary or Assistant Secretary; or (b) duly executed (under seal, if required) by one or more Attorneys-in-Fact and Agents pursuant to the power prescribed in his or her certificate or their certificates of authority or by one or more Company officers pursuant to a written delegation of authority; and it is

**FURTHER RESOLVED**, that the signature of each of the following officers: President, any Executive Vice President, any Senior Vice President, any Vice President, any Assistant Vice President, any Secretary, any Assistant Secretary, and the seal of the Company may be affixed by facsimile to any Power of Attorney or to any certificate relating thereto appointing Resident Vice Presidents, Resident Assistant Secretaries or Attorneys-in-Fact for purposes only of executing and attesting bonds and undertakings and other writings obligatory in the nature thereof, and any such Power of Attorney or certificate bearing such facsimile signature or facsimile seal shall be valid and binding upon the Company and any such power so executed and certified by such facsimile signature and facsimile seal shall be valid and binding on the Company in the future with respect to any bond or understanding to which it is attached.

I, Kevin E. Hughes, the undersigned, Assistant Secretary, of Farmington Casualty Company, Fidelity and Guaranty Insurance Company, Fidelity and Guaranty Insurance Underwriters, Inc., St. Paul Fire and Marine Insurance Company, St. Paul Guardian Insurance Company, St. Paul Mercury Insurance Company, Travelers Casualty and Surety Company, Travelers Casualty and Surety Company of America, and United States Fidelity and Guaranty Company do hereby certify that the above and foregoing is a true and correct copy of the Power of Attorney executed by said Companies, which is in full force and effect and has not been revoked.

IN TESTIMONY WHEREOF, I have hereunto set my hand and affixed the seals of said Companies this 21<sup>ST</sup> day of November, 2010

*Kevin E. Hughes*  
Kevin E. Hughes, Assistant Secretary



To verify the authenticity of this Power of Attorney, call 1-800-421-3880 or contact us at www.travelersbond.com. Please refer to the Attorney-In-Fact number, the above-named individuals and the details of the bond to which the power is attached.

EROSION AND SEDIMENT CONTROL PERFORMANCE BOND

KNOW ALL MEN BY THESE PRESENTS, that

WRC1, LLC dba W. Rogers Company  
649 Bizzell Drive  
Lexington, Kentucky 40510

a Limited Liability Company, hereinafter called Principal, and  
Travelers Casualty and Surety Company of America  
Hartford, CT

hereinto called Surety, are held and firmly bound unto

LEXINGTON-FAYETTE URBAN COUNTY GOVERNMENT  
200 East Main Street, Third Floor  
Lexington, Kentucky 40507

Obligee, hereinafter called "OWNER" in the penal sum of:

[1% of Total Bid Price] Fifty One Thousand Nine Hundred Seven dollars and Sixty Six cents (\$51,907.66), for the payment of whereof Principal and Surety bind themselves, their heirs, executors, administrators, successors, and assigns, jointly and severally, firmly by these presents.

WHEREAS, Principal by written agreement is entering into an Agreement (Contract) with OWNER for the Expansion Area 3 Pump Station Improvements, LFUCG Bid No. 106-2017 in accordance with Contract Documents prepared by HDR Engineering, Inc. and dated November 21, 2017, which Agreement (Contract) is by reference made a part hereof, and is hereinafter referred to as the Agreement (Contract).

NOW THEREFORE, THE CONDITION OF THIS OBLIGATION is such that if the Principal shall promptly and faithfully perform said Agreement (Contract), then this obligation shall be null and void; otherwise it shall remain in full force and effect.

The Surety hereby waives notice of any alteration or extension of time made by the OWNER.

Whenever, Principal shall be, and declared by OWNER to be in default under the Agreement (Contract), the OWNER having performed OWNER's obligations thereunder, the Surety may promptly remedy the default, or shall promptly:

1. Complete the installation, maintenance, and removal of the soil erosion and sediment controls and final stabilization of the site in accordance with the Agreement (Contract), the LFUCG Land Disturbance Permit, Chapter 16 Article X Division 5 of the LFUCG Code of Ordinances, and the KPDES General Permit for Stormwater Discharges Associated with Construction Activities (KYR 10).
2. Obtain a Bid or Bids for completing the installation, maintenance, and removal of the soil erosion and sediment controls and final stabilization of the site in accordance with the Agreement's (Contract's) terms and conditions, and upon determination by Surety of the lowest responsible bidder, or if the OWNER elects, upon determination by the OWNER and Surety jointly of the lowest responsible bidder, arrange for an Agreement (Contract) between such bidder and OWNER, and make available as Work progresses (even though there may be a default or a succession of defaults under the Agreement (Contract) or Agreements (Contracts) of completion arranged under this paragraph)

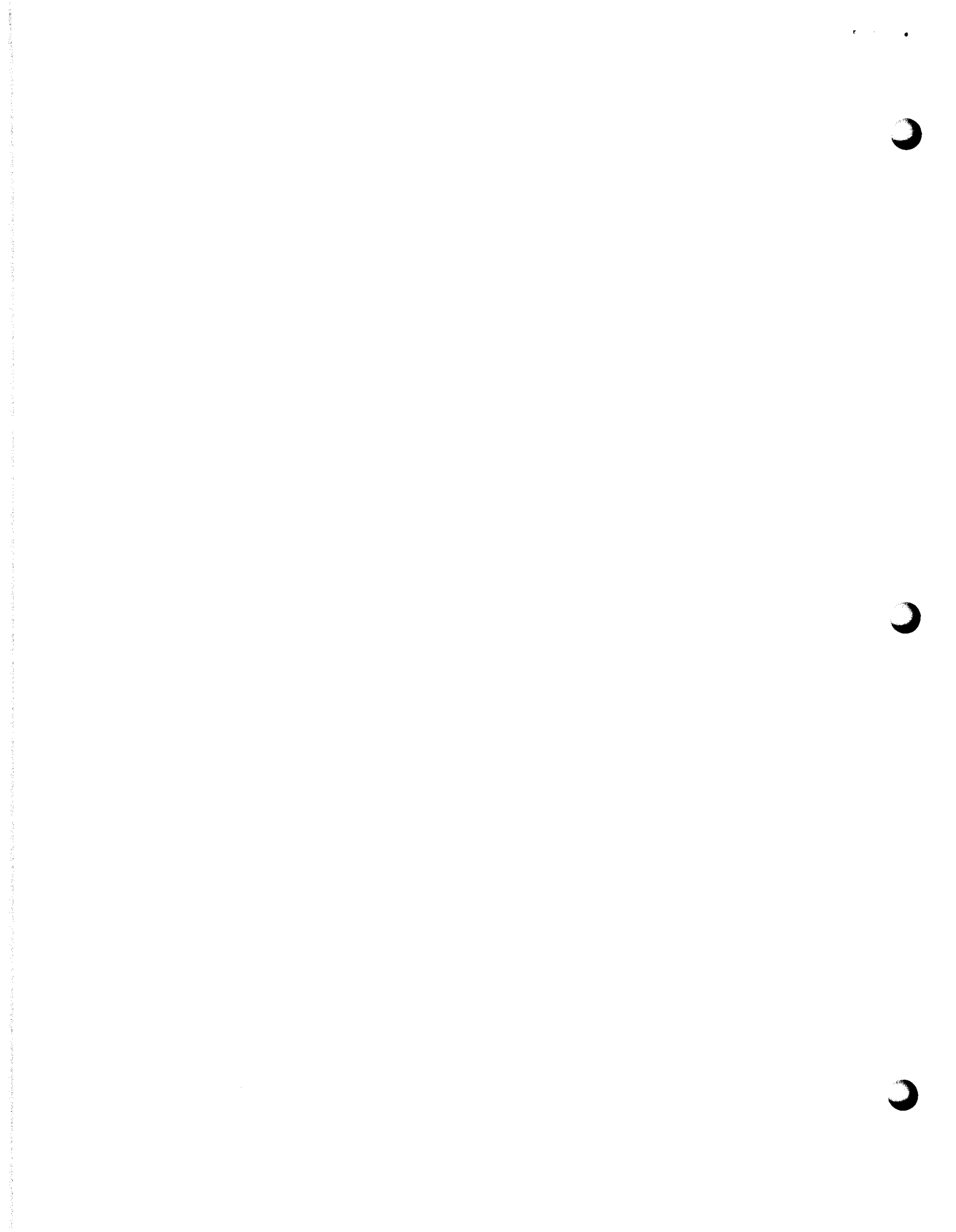



sufficient funds to pay the cost of completion less the balance of the Agreement (Contract) Amount; but not exceeding, including other costs and damages for which the Surety may be liable hereunder, the amount set forth in the first paragraph hereof. The term "balance of the Agreement (Contract) Amount", as used in this paragraph shall mean the total amount payable by OWNER to Principal under the Agreement (Contract) and any amendments hereto, less the amount properly paid by OWNER to Principal.

Any suit under this bond must be instituted before the expiration one (1) year from the date on which final payment under the Agreement (Contract) falls due.

No right of action shall accrue on this bond to or for the use of any person or corporation other than the OWNER named herein or the heirs, executors, administrators or successors of OWNER.

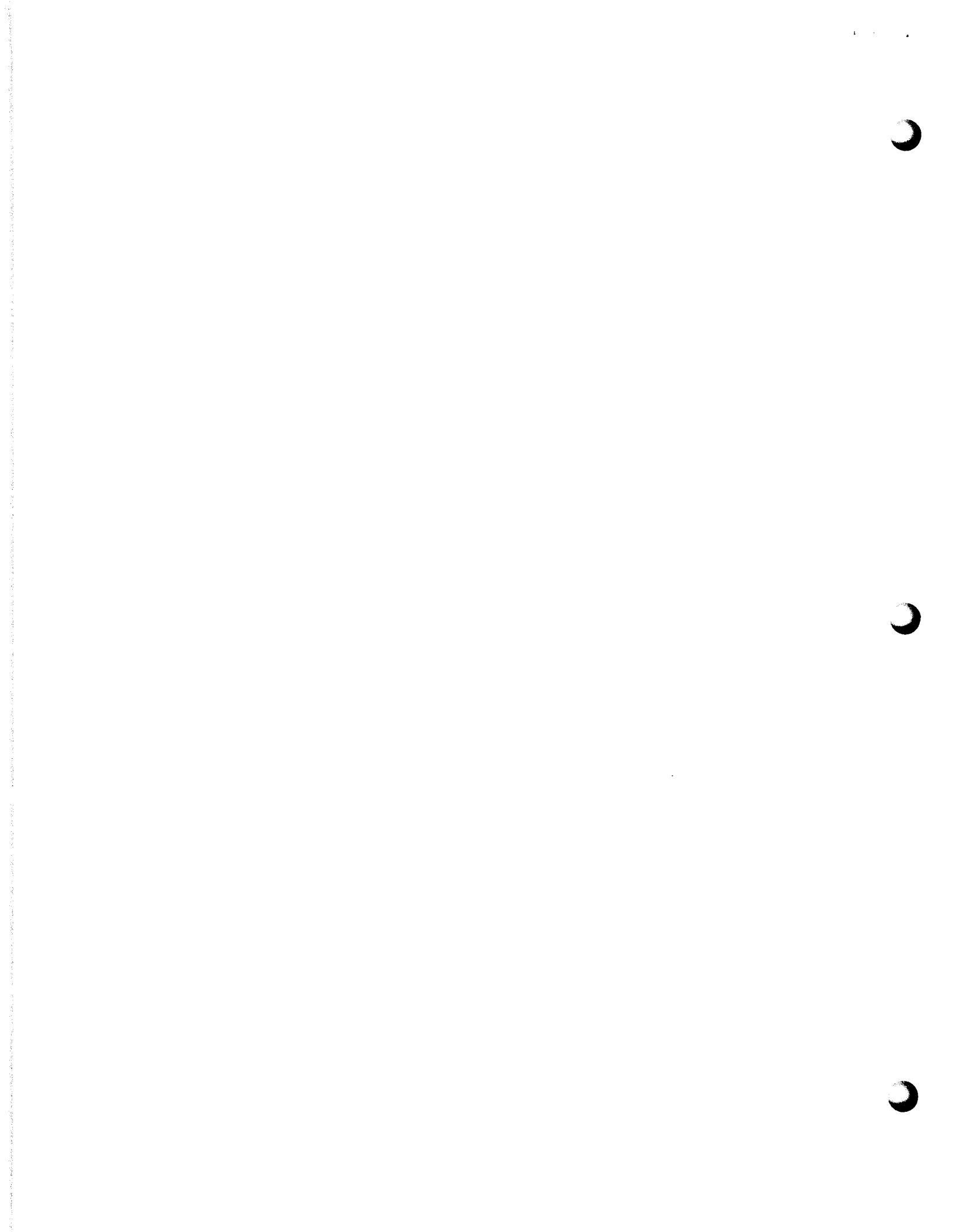

IN WITNESS WHEREOF, this instrument is executed in 5 counterparts, each one of

which shall be deemed an original, this the 21st day of November, 2017.

ATTEST:

X [Signature]  
(Principal) Secretary

WRC1, LLC dba W. Rogers Company  
Principal

By: X [Signature] (s)

649 Bizzell Drive

Address

Lexington, Kentucky 40510

X [Signature]  
Witness as to Principal

X 649 BIZZELL DRIVE  
Address

X LEXINGTON KY 40510

Travelers Casualty and Surety Co. of America  
Surety

By: [Signature]  
Attorney-in-Fact Anne Tierney

One Tower Square

Address

Hartford, Connecticut 06183

ATTEST:

[Signature]  
(Surety) Secretary  
Paulette M. Aerni

(SEAL)

Linda L. Hogle, Witness

Witness to Surety

312 Elm Street, 24th Floor

Address

Cincinnati, Ohio 45202

Title: Richard A. Davis, Witness

Surety

By: [Signature]

Title: Linda L. Hogle

NOTE: The number of executed counterparts of the bond shall coincide with the number of executed counterparts of the Agreement (Contract).

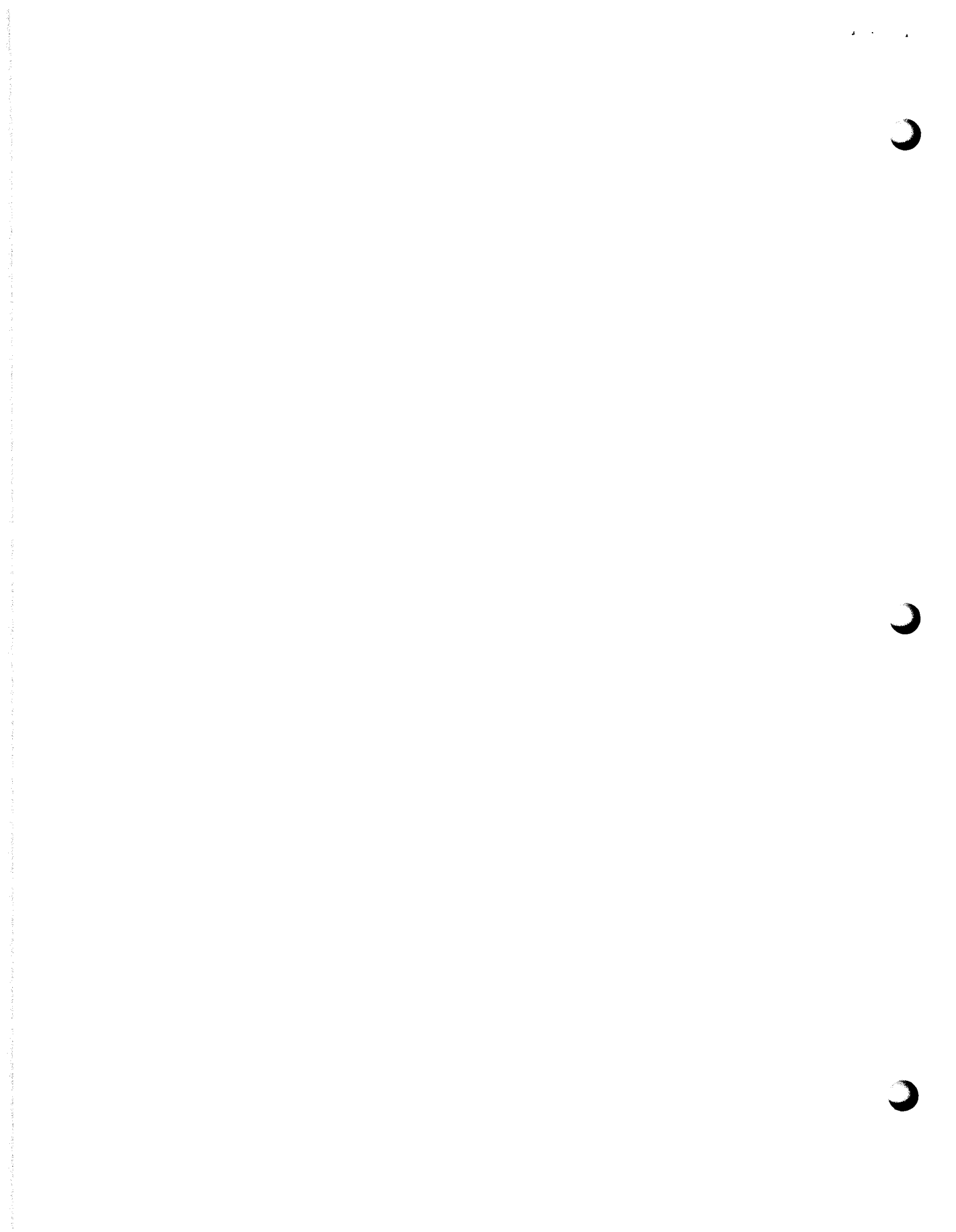



POWER OF ATTORNEY

Farmington Casualty Company
Fidelity and Guaranty Insurance Company
Fidelity and Guaranty Insurance Underwriters, Inc.
St. Paul Fire and Marine Insurance Company
St. Paul Guardian Insurance Company

St. Paul Mercury Insurance Company
Travelers Casualty and Surety Company
Travelers Casualty and Surety Company of America
United States Fidelity and Guaranty Company

Attorney-In Fact No. 224743

Certificate No. 007326179

KNOW ALL MEN BY THESE PRESENTS: That Farmington Casualty Company, St. Paul Fire and Marine Insurance Company, St. Paul Guardian Insurance Company, St. Paul Mercury Insurance Company, Travelers Casualty and Surety Company, Travelers Casualty and Surety Company of America, and United States Fidelity and Guaranty Company are corporations duly organized under the laws of the State of Connecticut, that Fidelity and Guaranty Insurance Company is a corporation duly organized under the laws of the State of Iowa, and that Fidelity and Guaranty Insurance Underwriters, Inc., is a corporation duly organized under the laws of the State of Wisconsin (herein collectively called the "Companies"), and that the Companies do hereby make, constitute and appoint

Thomas W. Chatham, Richard A. Davis, Paulette M. Aerni, Thomas D. Cassidy, Anne Tierney, Linda L. Hogle, and Paul J. Schueler Jr.

of the City of Cincinnati, State of Ohio, their true and lawful Attorney(s)-in-Fact, each in their separate capacity if more than one is named above, to sign, execute, seal and acknowledge any and all bonds, recognizances, conditional undertakings and other writings obligatory in the nature thereof on behalf of the Companies in their business of guaranteeing the fidelity of persons, guaranteeing the performance of contracts and executing or guaranteeing bonds and undertakings required or permitted in any actions or proceedings allowed by law.

WITNESS WHEREOF, the Companies have caused this instrument to be signed and their corporate seals to be hereto affixed, this 8th day of August, 2017.

Farmington Casualty Company
Fidelity and Guaranty Insurance Company
Fidelity and Guaranty Insurance Underwriters, Inc.
St. Paul Fire and Marine Insurance Company
St. Paul Guardian Insurance Company

St. Paul Mercury Insurance Company
Travelers Casualty and Surety Company
Travelers Casualty and Surety Company of America
United States Fidelity and Guaranty Company



State of Connecticut
City of Hartford ss.

By: [Signature]
Robert L. Raney, Senior Vice President

On this the 8th day of August, 2017, before me personally appeared Robert L. Raney, who acknowledged himself to be the Senior Vice President of Farmington Casualty Company, Fidelity and Guaranty Insurance Company, Fidelity and Guaranty Insurance Underwriters, Inc., St. Paul Fire and Marine Insurance Company, St. Paul Guardian Insurance Company, St. Paul Mercury Insurance Company, Travelers Casualty and Surety Company, Travelers Casualty and Surety Company of America, and United States Fidelity and Guaranty Company, and that he, as such, being authorized so to do, executed the foregoing instrument for the purposes therein contained by signing on behalf of the corporations by himself as a duly authorized officer.

Witness Whereof, I hereunto set my hand and official seal.
Commission expires the 30th day of June, 2021.



[Signature]
Marie C. Tetreault, Notary Public

This Power of Attorney is granted under and by the authority of the following resolutions adopted by the Boards of Directors of Farmington Casualty Company, Fidelity and Guaranty Insurance Company, Fidelity and Guaranty Insurance Underwriters, Inc., St. Paul Fire and Marine Insurance Company, St. Paul Guardian Insurance Company, St. Paul Mercury Insurance Company, Travelers Casualty and Surety Company, Travelers Casualty and Surety Company of America, and United States Fidelity and Guaranty Company, which resolutions are now in full force and effect, reading as follows:

**RESOLVED**, that the Chairman, the President, any Vice Chairman, any Executive Vice President, any Senior Vice President, any Vice President, any Second Vice President, the Treasurer, any Assistant Treasurer, the Corporate Secretary or any Assistant Secretary may appoint Attorneys-in-Fact and Agents to act for and on behalf of the Company and may give such appointee such authority as his or her certificate of authority may prescribe to sign with the Company's name and seal with the Company's seal bonds, recognizances, contracts of indemnity, and other writings obligatory in the nature of a bond, recognizance, or conditional undertaking, and any of said officers or the Board of Directors at any time may remove any such appointee and revoke the power given him or her; and it is

**FURTHER RESOLVED**, that the Chairman, the President, any Vice Chairman, any Executive Vice President, any Senior Vice President or any Vice President may delegate all or any part of the foregoing authority to one or more officers or employees of this Company, provided that each such delegation is in writing and a copy thereof is filed in the office of the Secretary; and it is

**FURTHER RESOLVED**, that any bond, recognizance, contract of indemnity, or writing obligatory in the nature of a bond, recognizance, or conditional undertaking shall be valid and binding upon the Company when (a) signed by the President, any Vice Chairman, any Executive Vice President, any Senior Vice President or any Vice President, any Second Vice President, the Treasurer, any Assistant Treasurer, the Corporate Secretary or any Assistant Secretary and duly attested and sealed with the Company's seal by a Secretary or Assistant Secretary; or (b) duly executed (under seal, if required) by one or more Attorneys-in-Fact and Agents pursuant to the power prescribed in his or her certificate or their certificates of authority or by one or more Company officers pursuant to a written delegation of authority; and it is

**FURTHER RESOLVED**, that the signature of each of the following officers: President, any Executive Vice President, any Senior Vice President, any Vice President, any Assistant Vice President, any Secretary, any Assistant Secretary, and the seal of the Company may be affixed by facsimile to any Power of Attorney or to any certificate relating thereto appointing Resident Vice Presidents, Resident Assistant Secretaries or Attorneys-in-Fact for purposes only of executing and attesting bonds and undertakings and other writings obligatory in the nature thereof, and any such Power of Attorney or certificate bearing such facsimile signature or facsimile seal shall be valid and binding upon the Company and any such power so executed and certified by such facsimile signature and facsimile seal shall be valid and binding on the Company in the future with respect to any bond or understanding to which it is attached.

I, Kevin E. Hughes, the undersigned, Assistant Secretary, of Farmington Casualty Company, Fidelity and Guaranty Insurance Company, Fidelity and Guaranty Insurance Underwriters, Inc., St. Paul Fire and Marine Insurance Company, St. Paul Guardian Insurance Company, St. Paul Mercury Insurance Company, Travelers Casualty and Surety Company, Travelers Casualty and Surety Company of America, and United States Fidelity and Guaranty Company do hereby certify that the above and foregoing is a true and correct copy of the Power of Attorney executed by said Companies, which is in full force and effect and has not been revoked.

IN TESTIMONY WHEREOF, I have hereunto set my hand and affixed the seals of said Companies this 21<sup>ST</sup> day of November, 2010

  
Kevin E. Hughes, Assistant Secretary



To verify the authenticity of this Power of Attorney, call 1-800-421-3880 or contact us at [www.travelersbond.com](http://www.travelersbond.com). Please refer to the Attorney-In-Fact number, the above-named individuals and the details of the bond to which the power is attached.

WARRANTY BOND

KNOW ALL MEN BY THESE PRESENTS, that

WRC1, LLC dba W. Rogers Company  
649 Bizzell Drive  
Lexington, Kentucky 40510

a Limited Liability Company, hereinafter called Principal, and  
Travelers Casualty and Surety Company of America  
Hartford, CT

hereinto called Surety, are held and firmly bound unto

LEXINGTON-FAYETTE URBAN COUNTY GOVERNMENT  
200 East Main Street, Third Floor  
Lexington, Kentucky 40507

Obligee, hereinafter called "OWNER" in the penal sum of Five Million One Hundred Ninety Thousand Seven Hundred Sixty Six dollars (\$5,190,766.00), for the payment of whereof Principal and Surety bind themselves, their heirs, executors, administrators, successors, and assigns, jointly and severally, firmly by these presents. The warranty bond shall be in the amount of five percent (5%) of the final construction cost amount (based on contractor's final pay request).

WHEREAS, Principal by written agreement is entering into an Agreement (Contract) with OWNER for the Expansion Area 3 Pump Station Improvements, LFUCG Bid No. 106-2017 in accordance with Contract Documents prepared by HDR Engineering Inc. and dated November 21, 2017, which Agreement (Contract) is by reference made a part hereof, and is hereinafter referred to as the Agreement (Contract).

NOW, THEREFORE, THE CONDITION OF THE ABOVE OBLIGATION IS SUCH that, if the Principal shall well and faithfully do and perform the required maintenance and shall indemnify and save harmless the OWNER against all claims, loss or damage, and expenses of reconstruction or additional work required to restore the Project to its acceptable condition within a period of one (1) year from the date of acceptance by OWNER of the Project, then this obligation shall be void; otherwise, it shall remain in full force and effect.

The Surety hereby waives notice of any alteration or extension of time made by the OWNER.

Any suit under this bond must be instituted before the expiration of one (1) year from the date on which final payment under the Contract falls due.

No right of action shall accrue on this Bond to or for the use of any person or corporation other than the OWNER named herein or the heirs, executors, administrators, successors, or assigns of the OWNER.

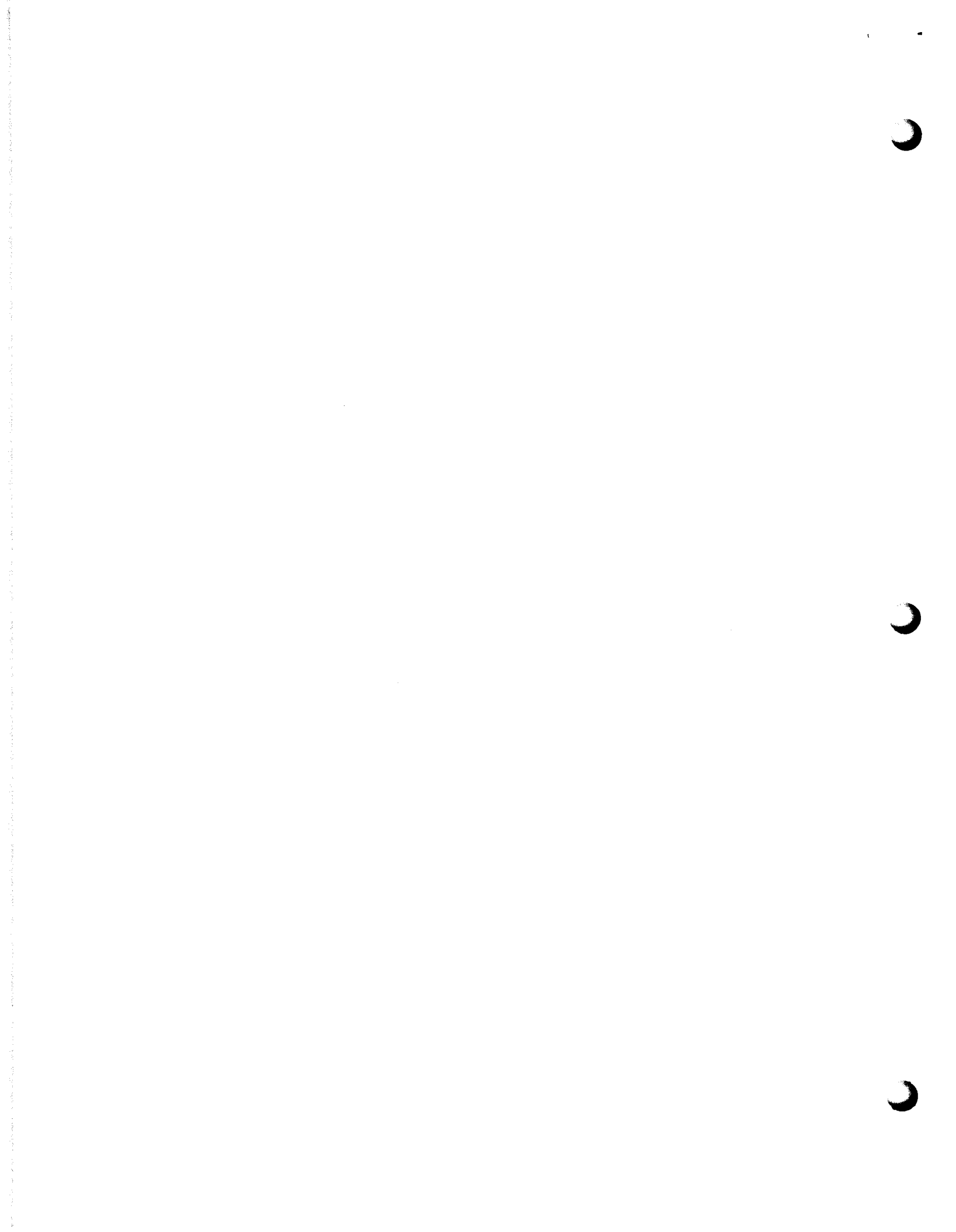



IN WITNESS WHEREOF, this instrument is executed in 5 counterparts, each one of

which shall be deemed an original, this the 21st day of November, 2017.

ATTEST:

x [Signature]  
(Principal) Secretary

WRC1, LLC dba W. Rogers Company  
Principal

By: [Signature] (s)

649 Bizzell Drive  
Address

Lexington, Kentucky 40510

x [Signature]  
Witness as to Principal

649 BIZZELL DRIVE  
Address

LEXINGTON KY 40510

Travelers Casualty and Surety Co. of America  
Surety

By: [Signature]  
Attorney-in-Fact Anne Tierney

One Tower Square  
Address

Hartford, Connecticut 06183

ATTEST:

[Signature]  
(Surety) Secretary  
Paulette M. Aerni

(SEAL)

Linda L. Hogle, Witness  
Witness to Surety

312 Elm Street, 24th Floor  
Address

Cincinnati, Ohio 45202

Title: Linda L. Hogle

Title: Richard A. Davis, Witness  
Surety

By: [Signature]

NOTE: The number of executed counterparts of the bond shall coincide with the number of executed counterparts of the Agreement (Contract).

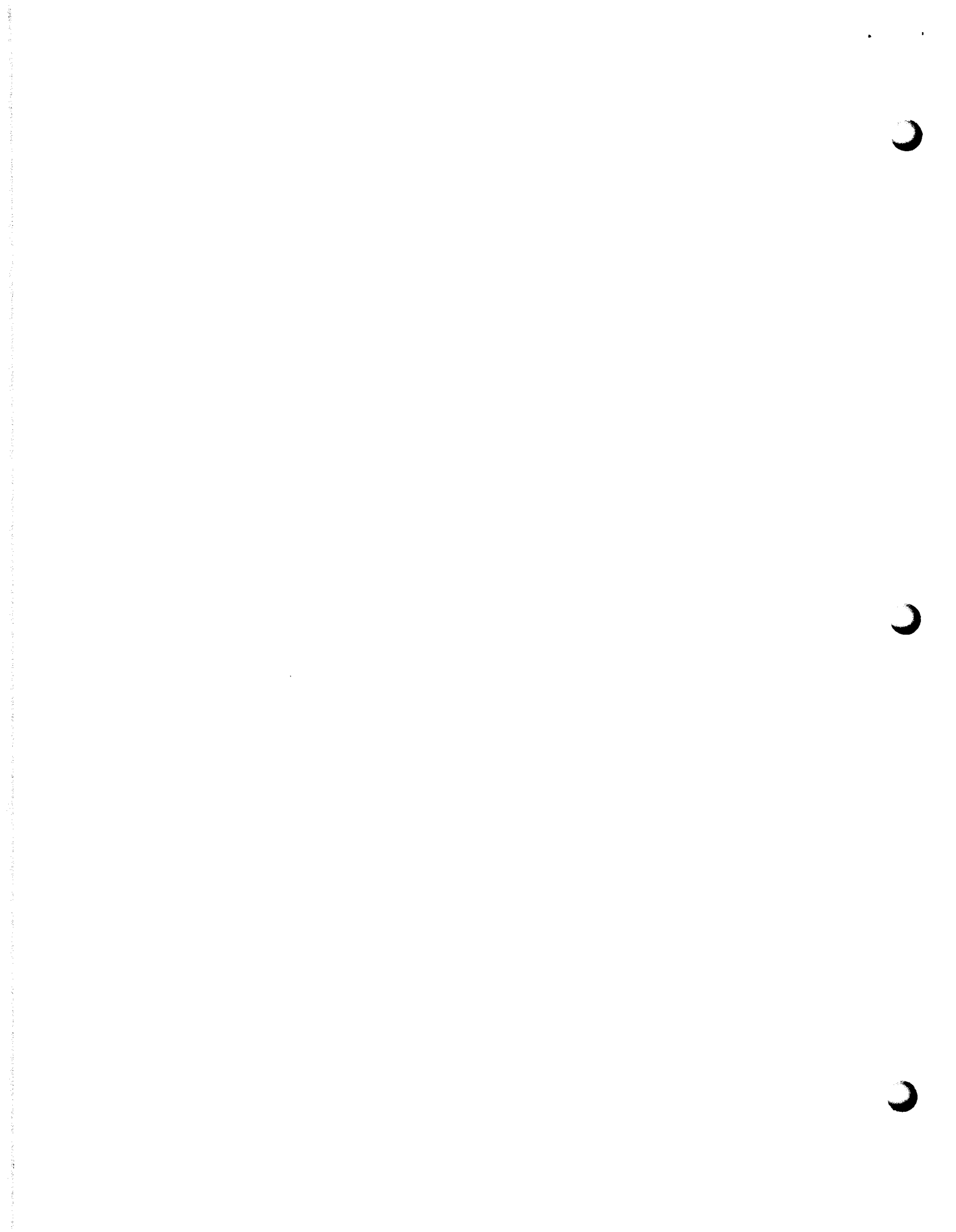



POWER OF ATTORNEY

Farmington Casualty Company
Fidelity and Guaranty Insurance Company
Fidelity and Guaranty Insurance Underwriters, Inc.
St. Paul Fire and Marine Insurance Company
St. Paul Guardian Insurance Company

St. Paul Mercury Insurance Company
Travelers Casualty and Surety Company
Travelers Casualty and Surety Company of America
United States Fidelity and Guaranty Company

Attorney-In Fact No. 224743

Certificate No. 007326183

KNOW ALL MEN BY THESE PRESENTS: That Farmington Casualty Company, St. Paul Fire and Marine Insurance Company, St. Paul Guardian Insurance Company, St. Paul Mercury Insurance Company, Travelers Casualty and Surety Company, Travelers Casualty and Surety Company of America, and United States Fidelity and Guaranty Company are corporations duly organized under the laws of the State of Connecticut, that Fidelity and Guaranty Insurance Company is a corporation duly organized under the laws of the State of Iowa, and that Fidelity and Guaranty Insurance Underwriters, Inc., is a corporation duly organized under the laws of the State of Wisconsin (herein collectively called the "Companies"), and that the Companies do hereby make, constitute and appoint

Thomas W. Chatham, Richard A. Davis, Paulette M. Aerni, Thomas D. Cassidy, Anne Tierney, Linda L. Hogle, and Paul J. Schueler Jr.

of the City of Cincinnati, State of Ohio, their true and lawful Attorney(s)-in-Fact, each in their separate capacity if more than one is named above, to sign, execute, seal and acknowledge any and all bonds, recognizances, conditional undertakings and other writings obligatory in the nature thereof on behalf of the Companies in their business of guaranteeing the fidelity of persons, guaranteeing the performance of contracts and executing or guaranteeing bonds and undertakings required or permitted in any actions or proceedings allowed by law.

WITNESS WHEREOF, the Companies have caused this instrument to be signed and their corporate seals to be hereto affixed, this 8th day of August, 2017.

Farmington Casualty Company
Fidelity and Guaranty Insurance Company
Fidelity and Guaranty Insurance Underwriters, Inc.
St. Paul Fire and Marine Insurance Company
St. Paul Guardian Insurance Company

St. Paul Mercury Insurance Company
Travelers Casualty and Surety Company
Travelers Casualty and Surety Company of America
United States Fidelity and Guaranty Company



State of Connecticut
City of Hartford ss.

By: Robert L. Raney, Senior Vice President

On this the 8th day of August, 2017, before me personally appeared Robert L. Raney, who acknowledged himself to be the Senior Vice President of Farmington Casualty Company, Fidelity and Guaranty Insurance Company, Fidelity and Guaranty Insurance Underwriters, Inc., St. Paul Fire and Marine Insurance Company, St. Paul Guardian Insurance Company, St. Paul Mercury Insurance Company, Travelers Casualty and Surety Company, Travelers Casualty and Surety Company of America, and United States Fidelity and Guaranty Company, and that he, as such, being authorized so to do, executed the foregoing instrument for the purposes therein contained by signing on behalf of the corporations by himself as a duly authorized officer.

Witness Whereof, I hereunto set my hand and official seal. Commission expires the 30th day of June, 2021.



Marie C. Tetreault
Marie C. Tetreault, Notary Public

This Power of Attorney is granted under and by the authority of the following resolutions adopted by the Boards of Directors of Farmington Casualty Company, Fidelity and Guaranty Insurance Company, Fidelity and Guaranty Insurance Underwriters, Inc., St. Paul Fire and Marine Insurance Company, St. Paul Guardian Insurance Company, St. Paul Mercury Insurance Company, Travelers Casualty and Surety Company, Travelers Casualty and Surety Company of America, and United States Fidelity and Guaranty Company, which resolutions are now in full force and effect, reading as follows:

**RESOLVED**, that the Chairman, the President, any Vice Chairman, any Executive Vice President, any Senior Vice President, any Vice President, any Second Vice President, the Treasurer, any Assistant Treasurer, the Corporate Secretary or any Assistant Secretary may appoint Attorneys-in-Fact and Agents to act for and on behalf of the Company and may give such appointee such authority as his or her certificate of authority may prescribe to sign with the Company's name and seal with the Company's seal bonds, recognizances, contracts of indemnity, and other writings obligatory in the nature of a bond, recognizance, or conditional undertaking, and any of said officers or the Board of Directors at any time may remove any such appointee and revoke the power given him or her; and it is

**FURTHER RESOLVED**, that the Chairman, the President, any Vice Chairman, any Executive Vice President, any Senior Vice President or any Vice President may delegate all or any part of the foregoing authority to one or more officers or employees of this Company, provided that each such delegation is in writing and a copy thereof is filed in the office of the Secretary; and it is

**FURTHER RESOLVED**, that any bond, recognizance, contract of indemnity, or writing obligatory in the nature of a bond, recognizance, or conditional undertaking shall be valid and binding upon the Company when (a) signed by the President, any Vice Chairman, any Executive Vice President, any Senior Vice President or any Vice President, any Second Vice President, the Treasurer, any Assistant Treasurer, the Corporate Secretary or any Assistant Secretary and duly attested and sealed with the Company's seal by a Secretary or Assistant Secretary; or (b) duly executed (under seal, if required) by one or more Attorneys-in-Fact and Agents pursuant to the power prescribed in his or her certificate or their certificates of authority or by one or more Company officers pursuant to a written delegation of authority; and it is

**FURTHER RESOLVED**, that the signature of each of the following officers: President, any Executive Vice President, any Senior Vice President, any Vice President, any Assistant Vice President, any Secretary, any Assistant Secretary, and the seal of the Company may be affixed by facsimile to any Power of Attorney or to any certificate relating thereto appointing Resident Vice Presidents, Resident Assistant Secretaries or Attorneys-in-Fact for purposes only of executing and attesting bonds and undertakings and other writings obligatory in the nature thereof, and any such Power of Attorney or certificate bearing such facsimile signature or facsimile seal shall be valid and binding upon the Company and any such power so executed and certified by such facsimile signature and facsimile seal shall be valid and binding on the Company in the future with respect to any bond or understanding to which it is attached.

I, Kevin E. Hughes, the undersigned, Assistant Secretary, of Farmington Casualty Company, Fidelity and Guaranty Insurance Company, Fidelity and Guaranty Insurance Underwriters, Inc., St. Paul Fire and Marine Insurance Company, St. Paul Guardian Insurance Company, St. Paul Mercury Insurance Company, Travelers Casualty and Surety Company, Travelers Casualty and Surety Company of America, and United States Fidelity and Guaranty Company do hereby certify that the above and foregoing is a true and correct copy of the Power of Attorney executed by said Companies, which is in full force and effect and has not been revoked.

IN TESTIMONY WHEREOF, I have hereunto set my hand and affixed the seals of said Companies this 21<sup>ST</sup> day of November, 2010

  
Kevin E. Hughes, Assistant Secretary



To verify the authenticity of this Power of Attorney, call 1-800-421-3880 or contact us at [www.travelersbond.com](http://www.travelersbond.com). Please refer to the Attorney-In-Fact number, the above-named individuals and the details of the bond to which the power is attached.

## 1.05 RISK MANAGEMENT PROVISIONS INSURANCE AND INDEMNIFICATION

### A. DEFINITIONS

The Contractor understands and agrees that the Risk Management Provisions of this Agreement (Contract) define the responsibilities of the Contractor to the Owner.

As used in these Risk Management Provisions, the terms "Contractor" and "Owner" shall be defined as follows:

1. "Contractor" means the contractor and its employees, agents, servants, owners, principals, licensees, assigns and subcontractors of any tier.
2. "Owner" means the Lexington-Fayette Urban County Government and its elected and appointed officials, employees, agents, boards, consultants, assigns, volunteers and successors in interest.

### B. INDEMNIFICATION AND HOLD HARMLESS PROVISION

1. It is understood and agreed by the parties that Contractor hereby assumes the entire responsibility and liability for any and all damages to persons or property caused by or resulting from or arising out of any act or omission on the part of Contractor under or in connection with this agreement and/or the provision of goods or services and the performance or failure to perform any work required thereby.
2. Contractor shall indemnify, save, hold harmless and defend the Owner from and against all liability, damages, and losses, including but not limited to, demands, claims, obligations, causes of action, judgments, penalties, fines, liens, costs, expenses, interest, defense costs and reasonable attorney's fees that are in any way incidental to or connected with, or that arise or are alleged to have arisen, directly or indirectly, from or by Contractor's performance or breach of the agreement and/or the provision of goods or services provided that: (a) it is attributable to personal injury, bodily injury, sickness, or death, or to injury to or destruction of property (including the loss of use resulting therefrom), or to or from the negligent acts, errors or omissions or willful misconduct of the Contractor; and (b) not caused solely by the active negligence or willful misconduct of the Owner.
3. In the event the Owner is alleged to be liable based upon the above, Contractor shall defend such allegations and shall bear all costs, fees and expenses of such defense, including but not limited to, all reasonable attorneys' fees and expenses, court costs, and expert witness fees and expenses, using attorneys approved in writing by the Owner, which approval shall not be unreasonably withheld.
4. These provisions shall in no way be limited by any financial responsibility or insurance requirements, and shall survive the termination of this Agreement (Contract).
5. The Work and services performed hereunder involve a Consent Decree as further explained in of Section 00100, provision 1.13 of these specifications. The provisions of that provision are incorporated herein by reference as if expressly stated.
6. Owner is a political subdivision of the Commonwealth of Kentucky. Contractor acknowledges and agrees that the Owner is unable to provide indemnity or otherwise save, hold harmless, or defend the Contractor in any manner.
7. All certificates of insurance shall name LFUCG and Hospice of the Bluegrass, Inc. as additional insured. (AD #4)

C. FINANCIAL RESPONSIBILITY

The Contractor understands and agrees that it shall, prior to final acceptance of its Bid and the commencement of any Work, demonstrate the ability to assure compliance with the Indemnity Agreement and other provisions of this Agreement (Contract).

D. INSURANCE REQUIREMENTS

Bidders' attention is directed to the following insurance requirements, as Bidders must confer with their respective insurance agents, brokers, or carriers to determine in advance of Bid submission the availability of the insurance coverage's and endorsements required herein. If an apparent low Bidder fails to comply strictly with the insurance requirements below, that Bidder shall be disqualified from the award of the Agreement (Contract), at the Owner's discretion.

1. Minimum Scope of Insurance

Coverage shall be at least as broad as:

- a. Insurance Services Office Commercial General Liability Coverage (Occurrence Form CG 00 01) or Insurance Services Office Form (CG 00 090 11 88 Owners and Contractors Protective Liability Coverage Form - Coverage for Operations of Designated Contractor).
- b. Insurance Services Office Form number CA 0001 covering Automobile Liability, code 1 (any auto).
- c. Workers Compensation Insurance as required by the Commonwealth of Kentucky and Employer's Liability Insurance.
- d. Builders Risk (Course of Construction) Insurance covering all risk of loss (including Earthquake & Flood Protection) less policy exclusions.
- e. Completed Operations Policy Duration Form 2010 & 2037
- f. Surety bonds as described below.
- g. Professional liability (if Design/Build).
- h. Contractor's Pollution Legal Liability and/or Asbestos Legal Liability and/or Errors and Omissions (if project involves environmental hazards).

2. Required Insurance Coverage

Contractor shall procure and maintain for the duration of this Agreement (Contract) the following or equivalent insurance policies at no less than the limits shown below and cause its subcontractors to maintain similar insurance with limits acceptable to Owner in order to protect Owner against claims for injuries to persons or damages to property which may arise from or in connection with the performance of the Work hereunder by Contractor. The cost of such insurance shall be included in any Bid.

**Coverage**

**Limits**

- 1. General Liability, including Operations Products and Completed Operations

\$1,000,000 per occurrence, \$2,000,000 aggregate for bodily injury, personal injury and property damage with a \$5,000,000 umbrella. If Commercial General Liability Insurance or other form with a general aggregate limit is used the general aggregate limit shall be at \$5,000,000 or higher.

- 2. Automobile Liability

\$1,000,000 combined single limit for bodily injury and property damage.

- |   |   |
|---|---|
| 3. Workers Compensation                             | As required by the Commonwealth of Kentucky   |
| 4. Employers' Liability                             | \$1,000,000 each accident, \$2,000,000 policy limit Bodily injury by disease, \$1,000,000 each employee bodily injury by disease.                           |
| 5. Builder's Risk – Installation Floater            | Completed value of the project with no coinsurance penalty provisions. Coverage includes LFUGG, all contractors and subcontractors involved in the project. |
| 6. Professional Liability                           | \$5,000,000 as needed for design/build.   |
| 7. Contractors Pollution - Asbestos Legal Liability | \$2,000,000 each occurrence - \$5,000,000 policy aggregate, including errors and omissions.   |
| 8. Umbrella or Excess Liability Policy              | \$5,000,000 per occurrence  |

The policies above shall contain the following conditions:

- a. All Certificates of Insurance forms used by the insurance carrier shall be properly filed and approved by the Department of Insurance for the Commonwealth of Kentucky (DOI). Owner shall be named as additional insured in the General Liability Policy and Commercial Automobile Liability Policy using the Kentucky DOI approved forms.
- b. The General Liability Policy shall be primary to any insurance or self-insurance retained by Owner.
- c. The General Liability Policy shall include a Products and Completed Operations endorsement or Premises and Operations Liability endorsement unless it is deemed not to apply by Owner.
- d. The General Liability Policy shall include an Explosion-Collapse Underground (XCU) endorsement.
- e. The General Liability Policy shall include a Pollution Liability and/or Environmental Casualty endorsement unless it is deemed not to apply by Owner.
- f. Owner shall be provided at least thirty (30) days advance written notice via certified mail, return receipt requested, in the event any of the required policies are canceled or non-renewed.
- g. Said coverage shall be written by insurers acceptable to Owner and shall be in a form acceptable to Owner. Insurance placed with insurers with a rating classification of no less than Excellent (A or A-) and a financial size category of no less than VIII, as defined by the most current Best's Key Rating Guide shall be deemed automatically acceptable.
- h. Owner requests that the Bidder obtain an Umbrella Liability policy with a limit of liability of \$ \_\_\_\_\_ and that this policy be renewed for one (1) year after completion of this project.

## 2. Renewals

After insurance has been approved by Owner, evidence of renewal of an expiring policy must be submitted to Owner, and may be submitted on a manually signed renewal endorsement form. If the policy or carrier has changed, however, new evidence of coverage must be submitted in accordance with these Insurance Requirements.

3. Deductibles and Self-Insured Programs

**IF CONTRACTOR INTENDS TO SUBMIT SELF-INSURANCE PLAN, IT MUST BE FORWARDED TO LEXINGTON-FAYETTE URBAN COUNTY GOVERNMENT, DIVISION OF RISK MANAGEMENT, 200 EAST MAIN STREET, LEXINGTON, KENTUCKY 40507 NO LATER THAN A MINIMUM OF FIVE (5) WORKING DAYS PRIOR TO BID OPENING DATE.** Self-insurance programs, deductibles, and self-insured retentions in insurance policies are subject to separate approval by Lexington-Fayette Urban County Government's Division of Risk Management, upon review of evidence of Contractor's financial capacity to respond to claims. Any such programs or retentions must provide Owner with at least the same protection from liability and defense of suits as would be afforded by first-dollar insurance coverage. If Contractor satisfies any portion of the insurance requirements through deductibles, self-insurance programs, or self-insured retentions, Contractor agrees to provide Lexington-Fayette Urban County Government, Division of Risk Management, the following data prior to the final acceptance of Bid and the commencement of work:

- a. Contractor's latest audited financial statement, including auditor's notes.
- b. Any records of any self-insured trust fund plan or policy and related accounting statement.
- c. Actuarial funding reports or retained losses.
- d. Risk Management Manual or a description of self-insurance and risk management program.
- e. A claim loss run summary for the previous five (5) years.
- f. Self-Insured Associations will be considered.

4. Safety and Loss Control

Contractor shall comply with all applicable federal, state, and local safety standards related to the performance of its works or services under this Agreement and take necessary action to protect the life, health and safety and property of all of its personnel on the job site, the public, and the Owner.

5. Verification of Coverage

Prior to award of bid, Contractor agrees to furnish Owner with all applicable Certificates of Insurance signed by a person authorized by the insurer to bind coverage on its behalf. If requested, Contractor shall provide Owner copies of all insurance policies, including all endorsements.

6. Right to Review, Audit and Inspect

Contractor understands and agrees that Owner may review, audit and inspect any and all of Contractor's records and operations to insure compliance with these Insurance Requirements.

7. Contractor understands and agrees that the failure to comply with any of these insurance, safety, or loss control provisions shall constitute default under this Agreement (Contract). Contractor also agrees that Owner may elect at its option any single remedy or penalty or any combination of remedies and penalties, as available, including but not limited to purchasing insurance and charging Contractor for any such insurance premiums purchased, or suspending or terminating this Agreement (Contract).



# CERTIFICATE OF LIABILITY INSURANCE

DATE (MM/DD/YYYY)  
11/22/2017

THIS CERTIFICATE IS ISSUED AS A MATTER OF INFORMATION ONLY AND CONFERS NO RIGHTS UPON THE CERTIFICATE HOLDER. THIS CERTIFICATE DOES NOT AFFIRMATIVELY OR NEGATIVELY AMEND, EXTEND OR ALTER THE COVERAGE AFFORDED BY THE POLICIES BELOW. THIS CERTIFICATE OF INSURANCE DOES NOT CONSTITUTE A CONTRACT BETWEEN THE ISSUING INSURER(S), AUTHORIZED REPRESENTATIVE OR PRODUCER, AND THE CERTIFICATE HOLDER.

**IMPORTANT:** If the certificate holder is an ADDITIONAL INSURED, the policy(ies) must have ADDITIONAL INSURED provisions or be endorsed. If SUBROGATION IS WAIVED, subject to the terms and conditions of the policy, certain policies may require an endorsement. A statement on this certificate does not confer any rights to the certificate holder in lieu of such endorsement(s).

<b>PRODUCER</b> USI Insurance Services LLC 312 Elm Street, 24th Floor Cincinnati, OH 45202 513 852-6300	<b>CONTACT NAME:</b> Beth Malone		
	<b>PHONE (A/C. No. Ext):</b> 513-852-6404	<b>FAX (A/C. No.):</b> 610-537-4375	
<b>E-MAIL ADDRESS:</b> beth.malone@usi.com			
<b>INSURER(S) AFFORDING COVERAGE</b>		<b>NAIC #</b>	
<b>INSURED</b> WRC1, LLC 649 Bizzell Drive Lexington, KY 40510	<b>INSURER A :</b> National Fire Insurance Co. of Hartford		20478
	<b>INSURER B :</b> Continental Insurance Company		35289
	<b>INSURER C :</b> Liberty Insurance Underwriters, Inc.		19917
	<b>INSURER D :</b> American Casualty Company of Reading PA		20427
	<b>INSURER E :</b> Valley Forge Insurance Company		20508
	<b>INSURER F :</b> Continental Casualty Company		20443

**COVERAGES**                      **CERTIFICATE NUMBER:**                      **REVISION NUMBER:**

THIS IS TO CERTIFY THAT THE POLICIES OF INSURANCE LISTED BELOW HAVE BEEN ISSUED TO THE INSURED NAMED ABOVE FOR THE POLICY PERIOD INDICATED. NOTWITHSTANDING ANY REQUIREMENT, TERM OR CONDITION OF ANY CONTRACT OR OTHER DOCUMENT WITH RESPECT TO WHICH THIS CERTIFICATE MAY BE ISSUED OR MAY PERTAIN, THE INSURANCE AFFORDED BY THE POLICIES DESCRIBED HEREIN IS SUBJECT TO ALL THE TERMS, EXCLUSIONS AND CONDITIONS OF SUCH POLICIES. LIMITS SHOWN MAY HAVE BEEN REDUCED BY PAID CLAIMS.

INSR LTR	TYPE OF INSURANCE	ADDL INSR	SUBR WVD	POLICY NUMBER	POLICY EFF (MM/DD/YYYY)	POLICY EXP (MM/DD/YYYY)	LIMITS
A	<input checked="" type="checkbox"/> COMMERCIAL GENERAL LIABILITY <input type="checkbox"/> CLAIMS-MADE <input checked="" type="checkbox"/> OCCUR			6045798834	09/30/2017	09/30/2018	EACH OCCURRENCE \$1,000,000 DAMAGE TO RENTED PREMISES (Ea occurrence) \$100,000 MED EXP (Any one person) \$15,000 PERSONAL & ADV INJURY \$1,000,000 GENERAL AGGREGATE \$2,000,000 PRODUCTS - COMP/OP AGG \$2,000,000 <b>Stop Gap</b> \$1,000,000
	GEN'L AGGREGATE LIMIT APPLIES PER: <input type="checkbox"/> POLICY <input checked="" type="checkbox"/> PRO-JECT <input type="checkbox"/> LOC OTHER:						
	<input checked="" type="checkbox"/> AUTOMOBILE LIABILITY <input checked="" type="checkbox"/> ANY AUTO OWNED AUTOS ONLY <input type="checkbox"/> SCHEDULED AUTOS <input checked="" type="checkbox"/> HIRED AUTOS ONLY <input checked="" type="checkbox"/> NON-OWNED AUTOS ONLY			6045783072	09/30/2017	09/30/2018	COMBINED SINGLE LIMIT (Ea accident) \$1,000,000 BODILY INJURY (Per person) \$ BODILY INJURY (Per accident) \$ PROPERTY DAMAGE (Per accident) \$ \$
	<input checked="" type="checkbox"/> UMBRELLA LIAB <input checked="" type="checkbox"/> OCCUR <input checked="" type="checkbox"/> EXCESS LIAB <input type="checkbox"/> CLAIMS-MADE			CUE5094596468	09/30/2017	09/30/2018	EACH OCCURRENCE \$5,000,000 AGGREGATE \$5,000,000 <b>Excess Liab.</b> \$20,000,000
C	<input type="checkbox"/> DED <input checked="" type="checkbox"/> RETENTION \$10,000			100005919305	09/30/2017	09/30/2018	PER STATUTE    OTH-ER
D	WORKERS COMPENSATION AND EMPLOYERS' LIABILITY ANY PROPRIETOR/PARTNER/EXECUTIVE OFFICER/MEMBER EXCLUDED? (Mandatory in NH) If yes, describe under DESCRIPTION OF OPERATIONS below		N/A	6045798848 Excluding: AK, ND, OH, WA, WY, PR & USVI	09/30/2017	09/30/2018	E.L. EACH ACCIDENT \$500,000 E.L. DISEASE - EA EMPLOYEE \$500,000 E.L. DISEASE - POLICY LIMIT \$500,000
F	Rented Equipment			C2097397653	09/30/2017	09/30/2018	\$1,500,000 Limit

DESCRIPTION OF OPERATIONS / LOCATIONS / VEHICLES (ACORD 101, Additional Remarks Schedule, may be attached if more space is required)  
 Lexington-Fayette Urban County Government and Hospice of the Bluegrass Inc. are provided additional insured status on the General Liability (ongoing & completed operations), Automobile Liability and Umbrella Liability policies per the automatic Additional Insured endorsements on the General Liability and Automobile Liability policies (Umbrella follows the GL & Auto additional insured provision), only when the Named Insured has a written contract that requires such status, and only with regard to work performed by (See Attached Descriptions)

<b>CERTIFICATE HOLDER</b> Lexington-Fayette Urban County Government 200 East Main Street, Third Floor Lexington, KY 40507	<b>CANCELLATION</b> SHOULD ANY OF THE ABOVE DESCRIBED POLICIES BE CANCELLED BEFORE THE EXPIRATION DATE THEREOF, NOTICE WILL BE DELIVERED IN ACCORDANCE WITH THE POLICY PROVISIONS.  AUTHORIZED REPRESENTATIVE 
--	--

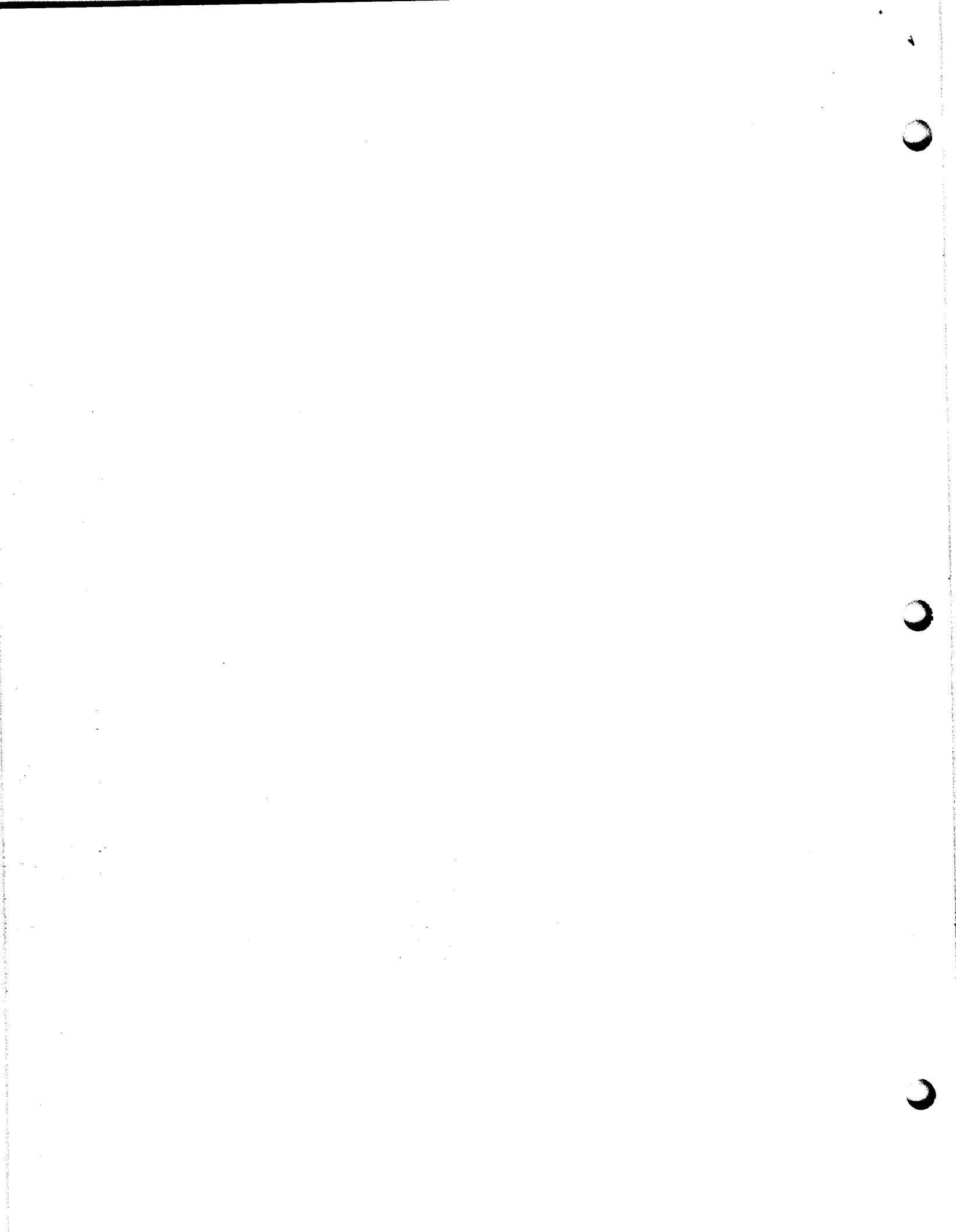

## DESCRIPTIONS (Continued from Page 1)

or on behalf of the named insured. This coverage applies on a primary and noncontributory basis when required by written contract with the named insured subject to policy terms and conditions. The Umbrella Liability policy follows the primary General Liability, Automobile Liability and Employers Liability policies.

A Blanket Waiver of Subrogation is included on the Workers Compensation policy where required by written contract, except in the excluded States above and KY, MO, NH & NJ.

Stop Gap coverage includes the States of OH, ND, WA & WY.

The General Liability, Automobile Liability, Umbrella Liability and Workers Compensation policies indicated above have been endorsed to provide thirty (30) days cancellation notice to the Certificate Holder - except for non-payment cancellation or when cancellation is requested by the named insured.

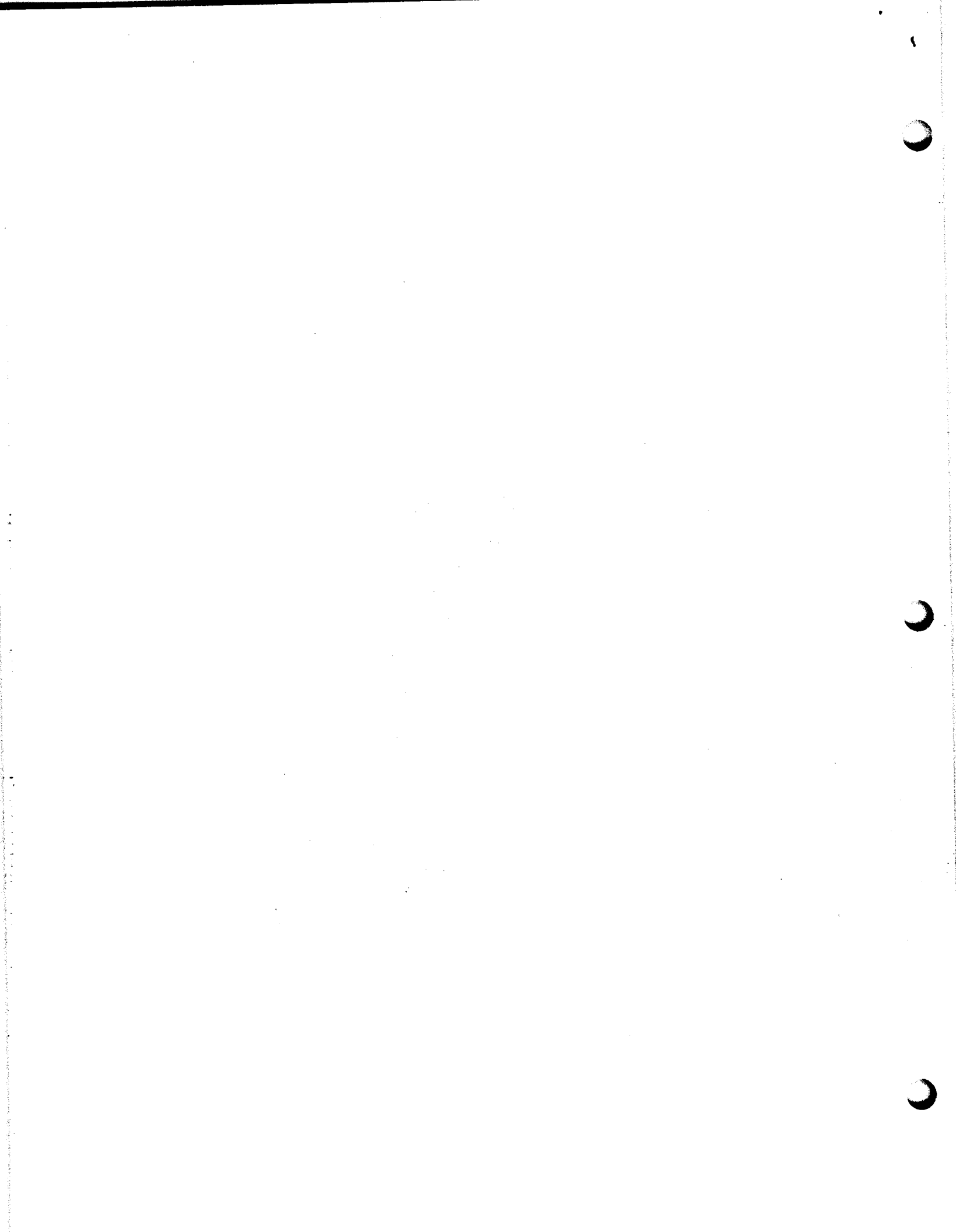

**EVIDENCE OF PROPERTY INSURANCE**

DATE (MM/DD/YYYY)

11/22/2017

THIS EVIDENCE OF PROPERTY INSURANCE IS ISSUED AS A MATTER OF INFORMATION ONLY AND CONFERS NO RIGHTS UPON THE ADDITIONAL INTEREST NAMED BELOW. THIS EVIDENCE DOES NOT AFFIRMATIVELY OR NEGATIVELY AMEND, EXTEND OR ALTER THE COVERAGE AFFORDED BY THE POLICIES BELOW. THIS EVIDENCE OF INSURANCE DOES NOT CONSTITUTE A CONTRACT BETWEEN THE ISSUING INSURER(S), AUTHORIZED REPRESENTATIVE OR PRODUCER, AND THE ADDITIONAL INTEREST.

AGENCY <b>USI Insurance Services LLC</b> 312 Elm Street, 24th Floor Cincinnati, OH 45202		PHONE (A/C. No. Ext): <b>513 852-6300</b>	COMPANY Continental Casualty Company	
FAX (A/C. No.): <b>610-537-4375</b>	E-MAIL ADDRESS: <b>beth.malone@usi.com</b>			
CODE:	SUB CODE:			
AGENCY CUSTOMER ID #: <b>1423137</b>		LOAN NUMBER		POLICY NUMBER <b>C2097397653</b>
INSURED <b>WRC1, LLC</b> 649 Bizzell Drive Lexington, KY 40510		EFFECTIVE DATE <b>09/30/17</b>	EXPIRATION DATE <b>09/30/18</b>	<input type="checkbox"/> CONTINUED UNTIL TERMINATED IF CHECKED
THIS REPLACES PRIOR EVIDENCE DATED:				

**PROPERTY INFORMATION**

LOCATION/DESCRIPTION  
**Expansion Area 3 Pump Station Improvements - LFUCG Bid No. 106-2017**

THE POLICIES OF INSURANCE LISTED BELOW HAVE BEEN ISSUED TO THE INSURED NAMED ABOVE FOR THE POLICY PERIOD INDICATED. NOTWITHSTANDING ANY REQUIREMENT, TERM OR CONDITION OF ANY CONTRACT OR OTHER DOCUMENT WITH RESPECT TO WHICH THIS EVIDENCE OF PROPERTY INSURANCE MAY BE ISSUED OR MAY PERTAIN, THE INSURANCE AFFORDED BY THE POLICIES DESCRIBED HEREIN IS SUBJECT TO ALL THE TERMS, EXCLUSIONS AND CONDITIONS OF SUCH POLICIES. LIMITS SHOWN MAY HAVE BEEN REDUCED BY PAID CLAIMS.

**COVERAGE INFORMATION**

COVERAGE/PERILS/FORMS	AMOUNT OF INSURANCE	DEDUCTIBLE
Blanket Builder's Risk/Installation Policy		
Jobsite Limit *	\$10,000,000	\$5,000
Temporary Storage Location Limit	\$2,000,000	\$5,000
Transit Limit	\$1,000,000	\$5,000
Flood & Earthquake (low & moderate hazard areas)	\$5,000,000	\$50,000
*Frame & Joisted Masonry construction @ \$5,000,000		

REMARKS (Including Special Conditions)  
**Supplemental Named Insureds include Project Owner, General Contractor, Construction Manager, Subcontractors, Architect, Engineer & Surveyor**

CANCELLATION  
SHOULD ANY OF THE ABOVE DESCRIBED POLICIES BE CANCELLED BEFORE THE EXPIRATION DATE THEREOF, NOTICE WILL BE DELIVERED IN ACCORDANCE WITH THE POLICY PROVISIONS.

ADDITIONAL INTEREST

NAME AND ADDRESS <b>Lexington-Fayette Urban County Government</b> 200 East Main Street, Third Floor Lexington, Kentucky 40507	MORTGAGEE	ADDITIONAL INSURED
	LOSS PAYEE	
	LOAN #	
AUTHORIZED REPRESENTATIVE <i>Thomas W. Chisum</i>		

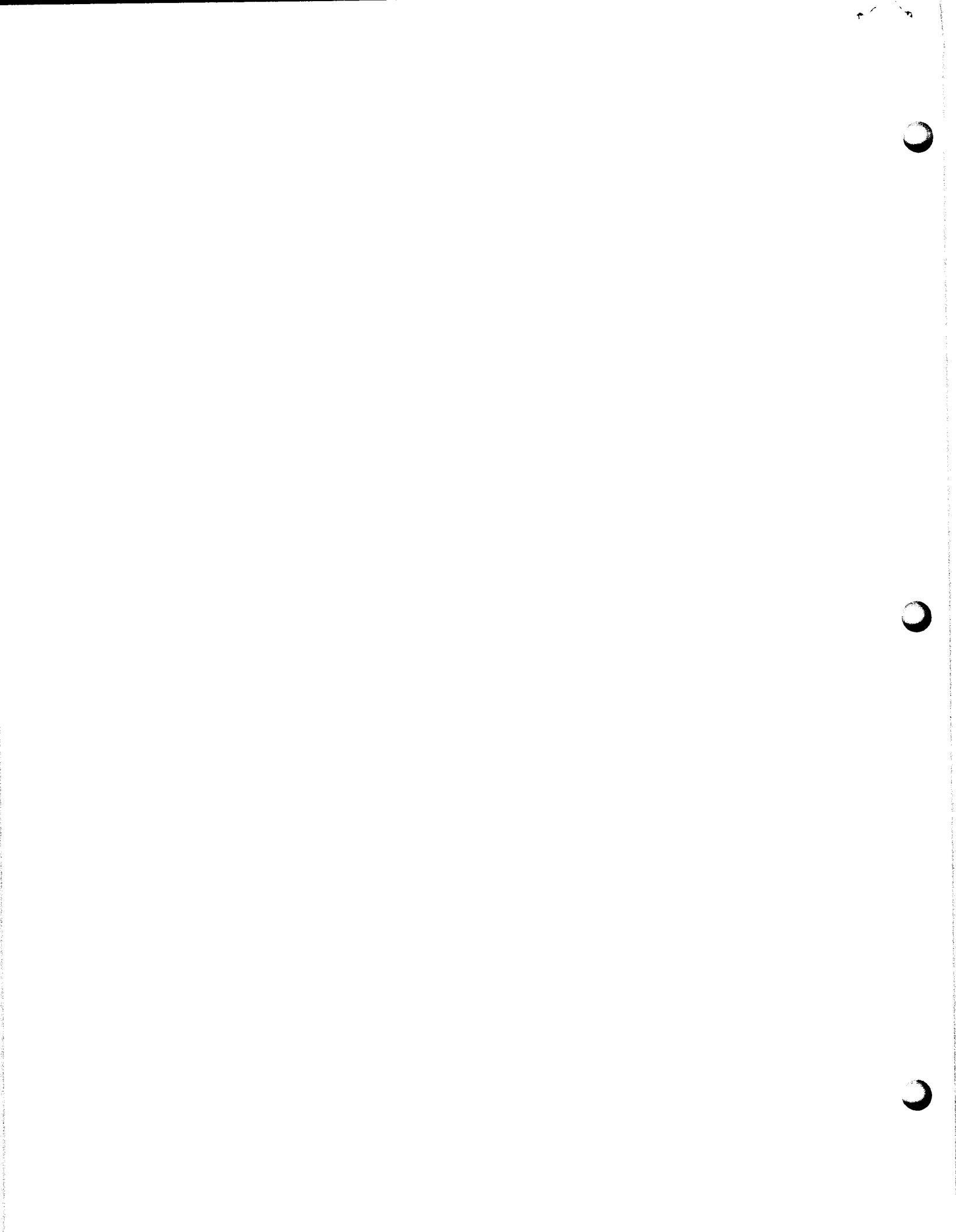

This page has been left blank intentionally.

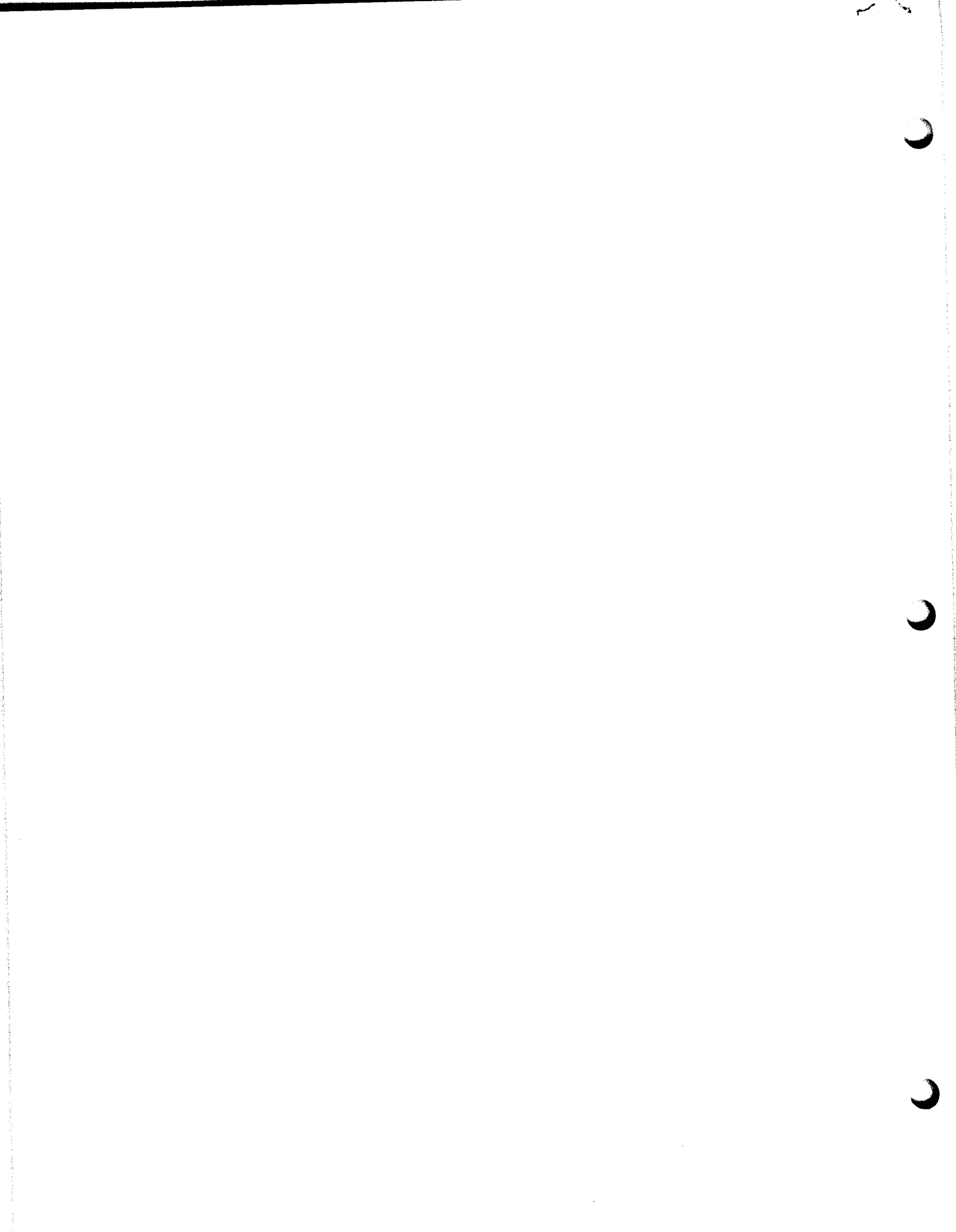



**SECTION 00700 – GENERAL CONDITIONS**

(This page is intentionally left blank).

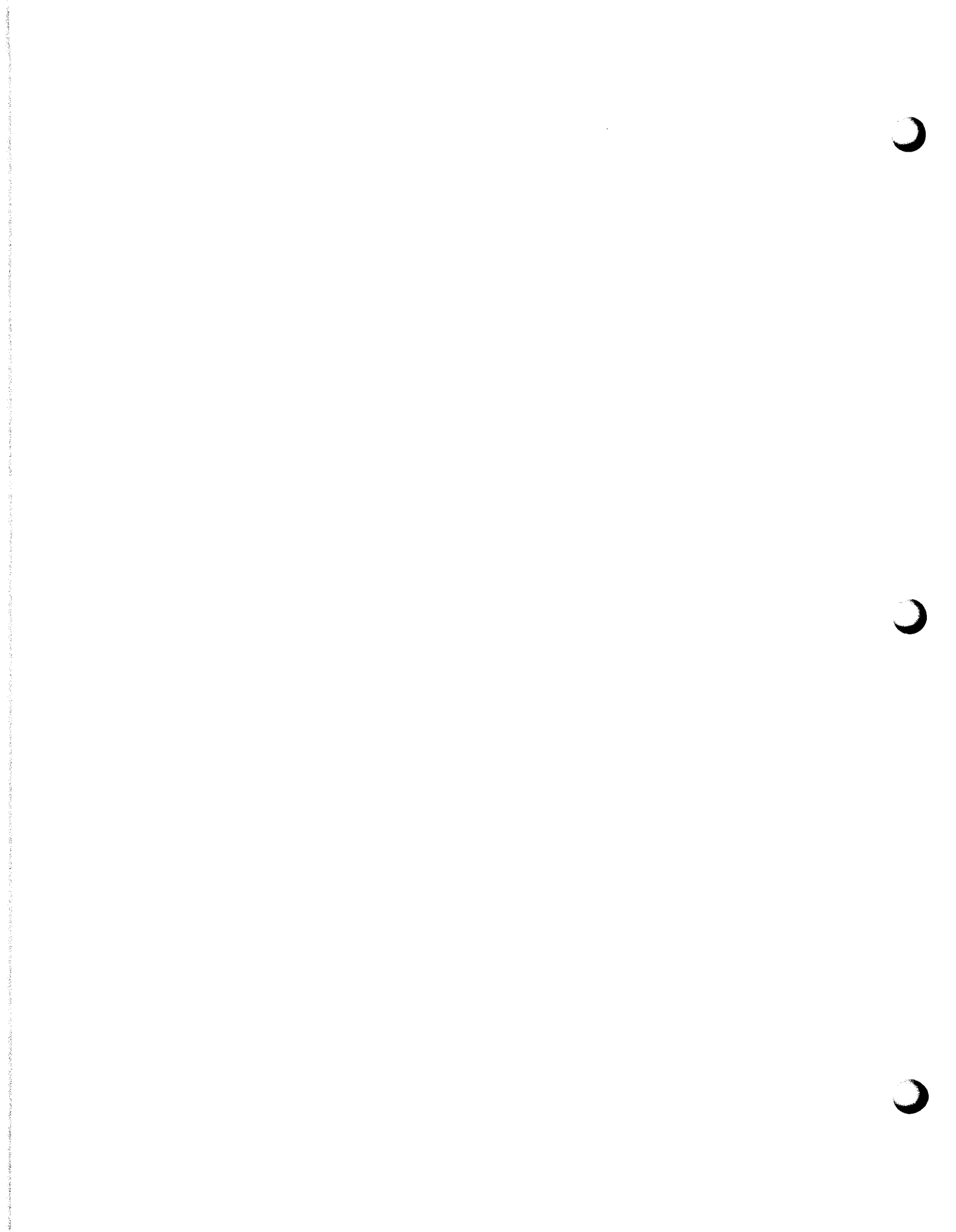

This document has important legal consequences; consultation with an attorney is encouraged with respect to its use or modification. This document should be adapted to the particular circumstances of the contemplated Project and the controlling Laws and Regulations.

# STANDARD GENERAL CONDITIONS OF THE CONSTRUCTION CONTRACT

Prepared by

**ENGINEERS JOINT CONTRACT DOCUMENTS COMMITTEE**

and

Issued and Published Jointly by



AMERICAN COUNCIL OF ENGINEERING COMPANIES

ASSOCIATED GENERAL CONTRACTORS OF AMERICA

AMERICAN SOCIETY OF CIVIL ENGINEERS

PROFESSIONAL ENGINEERS IN PRIVATE PRACTICE  
*A Practice Division of the*  
NATIONAL SOCIETY OF PROFESSIONAL ENGINEERS

Endorsed by



CONSTRUCTION SPECIFICATIONS INSTITUTE

These General Conditions have been prepared for use with the Suggested Forms of Agreement Between Owner and Contractor (EJCDC C-520 or C-525, 2007 Editions). Their provisions are interrelated and a change in one may necessitate a change in the other. Comments concerning their usage are contained in the Narrative Guide to the EJCDC Construction Documents (EJCDC C-001, 2007 Edition). For guidance in the preparation of Supplementary Conditions, see Guide to the Preparation of Supplementary Conditions (EJCDC C-800, 2007 Edition).

Copyright © 2007 National Society of Professional Engineers  
1420 King Street, Alexandria, VA 22314-2794  
(703) 684-2882  
[www.nspe.org](http://www.nspe.org)

American Council of Engineering Companies  
1015 15th Street N.W., Washington, DC 20005  
(202) 347-7474  
[www.acec.org](http://www.acec.org)

American Society of Civil Engineers  
1801 Alexander Bell Drive, Reston, VA 20191-4400  
(800) 548-2723  
[www.asce.org](http://www.asce.org)

Associated General Contractors of America  
2300 Wilson Boulevard, Suite 400, Arlington, VA 22201-3308  
(703) 548-3118  
[www.agc.org](http://www.agc.org)

The copyright for this EJCDC document is owned jointly by the four EJCDC sponsoring organizations and held in trust for their benefit by NSPE.

# STANDARD GENERAL CONDITIONS OF THE CONSTRUCTION CONTRACT

## TABLE OF CONTENTS

	Page
Article 1 – Definitions and Terminology .....	1
1.01 Defined Terms.....	1
1.02 Terminology.....	5
Article 2 – Preliminary Matters .....	6
2.01 Delivery of Bonds and Evidence of Insurance .....	6
2.02 Copies of Documents.....	6
2.03 Commencement of Contract Times; Notice to Proceed.....	6
2.04 Starting the Work .....	7
2.05 Before Starting Construction .....	7
2.06 Preconstruction Conference; Designation of Authorized Representatives.....	7
2.07 Initial Acceptance of Schedules.....	7
Article 3 – Contract Documents: Intent, Amending, Reuse .....	8
3.01 Intent.....	8
3.02 Reference Standards.....	8
3.03 Reporting and Resolving Discrepancies.....	9
3.04 Amending and Supplementing Contract Documents.....	9
3.05 Reuse of Documents .....	10
3.06 Electronic Data.....	10
Article 4 – Availability of Lands; Subsurface and Physical Conditions; Hazardous Environmental Conditions; Reference Points.....	11
4.01 Availability of Lands.....	11
4.02 Subsurface and Physical Conditions.....	11
4.03 Differing Subsurface or Physical Conditions .....	12
4.04 Underground Facilities.....	13
4.05 Reference Points.....	14
4.06 Hazardous Environmental Condition at Site.....	14
Article 5 – Bonds and Insurance.....	16
5.01 Performance, Payment, and Other Bonds.....	16
5.02 Licensed Sureties and Insurers.....	16
5.03 Certificates of Insurance .....	17
5.04 Contractor’s Insurance .....	17
5.05 Owner’s Liability Insurance.....	19
5.06 Property Insurance.....	19
5.07 Waiver of Rights .....	20
5.08 Receipt and Application of Insurance Proceeds .....	21

5.09	Acceptance of Bonds and Insurance; Option to Replace .....	21
5.10	Partial Utilization, Acknowledgment of Property Insurer.....	22
Article 6 – Contractor’s Responsibilities .....		22
6.01	Supervision and Superintendence.....	22
6.02	Labor; Working Hours.....	22
6.03	Services, Materials, and Equipment .....	22
6.04	Progress Schedule .....	23
6.05	Substitutes and “Or-Equals” .....	23
6.06	Concerning Subcontractors, Suppliers, and Others.....	25
6.07	Patent Fees and Royalties .....	27
6.08	Permits.....	27
6.09	Laws and Regulations .....	28
6.10	Taxes .....	28
6.11	Use of Site and Other Areas.....	28
6.12	Record Documents .....	29
6.13	Safety and Protection .....	29
6.14	Safety Representative.....	30
6.15	Hazard Communication Programs.....	30
6.16	Emergencies .....	30
6.17	Shop Drawings and Samples .....	31
6.18	Continuing the Work.....	32
6.19	Contractor’s General Warranty and Guarantee .....	33
6.20	Indemnification .....	33
6.21	Delegation of Professional Design Services.....	34
Article 7 – Other Work at the Site.....		35
7.01	Related Work at Site .....	35
7.02	Coordination.....	35
7.03	Legal Relationships.....	36
Article 8 – Owner’s Responsibilities.....		36
8.01	Communications to Contractor.....	36
8.02	Replacement of Engineer.....	36
8.03	Furnish Data.....	36
8.04	Pay When Due.....	36
8.05	Lands and Easements; Reports and Tests.....	36
8.06	Insurance.....	37
8.07	Change Orders.....	37
8.08	Inspections, Tests, and Approvals .....	37
8.09	Limitations on Owner’s Responsibilities .....	37
8.10	Undisclosed Hazardous Environmental Condition .....	37
8.11	Evidence of Financial Arrangements.....	37
8.12	Compliance with Safety Program.....	37
Article 9 – Engineer’s Status During Construction.....		37
9.01	Owner’s Representative .....	37

9.02	Visits to Site .....	38
9.03	Project Representative.....	38
9.04	Authorized Variations in Work .....	38
9.05	Rejecting Defective Work.....	39
9.06	Shop Drawings, Change Orders and Payments.....	39
9.07	Determinations for Unit Price Work .....	39
9.08	Decisions on Requirements of Contract Documents and Acceptability of Work.....	39
9.09	Limitations on Engineer's Authority and Responsibilities .....	40
9.10	Compliance with Safety Program.....	40
Article 10 – Changes in the Work; Claims .....		40
10.01	Authorized Changes in the Work .....	40
10.02	Unauthorized Changes in the Work.....	41
10.03	Execution of Change Orders.....	41
10.04	Notification to Surety.....	41
10.05	Claims.....	41
Article 11 – Cost of the Work; Allowances; Unit Price Work.....		42
11.01	Cost of the Work.....	42
11.02	Allowances.....	45
11.03	Unit Price Work .....	46
Article 12 – Change of Contract Price; Change of Contract Times .....		46
12.01	Change of Contract Price.....	46
12.02	Change of Contract Times .....	47
12.03	Delays.....	48
Article 13 – Tests and Inspections; Correction, Removal or Acceptance of Defective Work.....		48
13.01	Notice of Defects.....	48
13.02	Access to Work .....	48
13.03	Tests and Inspections .....	49
13.04	Uncovering Work.....	49
13.05	Owner May Stop the Work.....	50
13.06	Correction or Removal of Defective Work .....	50
13.07	Correction Period .....	50
13.08	Acceptance of Defective Work.....	51
13.09	Owner May Correct Defective Work .....	52
Article 14 – Payments to Contractor and Completion .....		52
14.01	Schedule of Values.....	52
14.02	Progress Payments .....	53
14.03	Contractor's Warranty of Title.....	55
14.04	Substantial Completion.....	55
14.05	Partial Utilization .....	56
14.06	Final Inspection.....	57
14.07	Final Payment.....	57
14.08	Final Completion Delayed.....	58

14.09 Waiver of Claims .....	58
Article 15 – Suspension of Work and Termination .....	59
15.01 Owner May Suspend Work.....	59
15.02 Owner May Terminate for Cause .....	59
15.03 Owner May Terminate For Convenience .....	60
15.04 Contractor May Stop Work or Terminate.....	61
Article 16 – Dispute Resolution .....	61
16.01 Methods and Procedures .....	61
Article 17 – Miscellaneous .....	62
17.01 Giving Notice .....	62
17.02 Computation of Times .....	62
17.03 Cumulative Remedies .....	62
17.04 Survival of Obligations .....	62
17.05 Controlling Law .....	62
17.06 Headings.....	62



## ARTICLE 1 – DEFINITIONS AND TERMINOLOGY

### 1.01 *Defined Terms*

- A. Wherever used in the Bidding Requirements or Contract Documents and printed with initial capital letters, the terms listed below will have the meanings indicated which are applicable to both the singular and plural thereof. In addition to terms specifically defined, terms with initial capital letters in the Contract Documents include references to identified articles and paragraphs, and the titles of other documents or forms.
1. *Addenda*—Written or graphic instruments issued prior to the opening of Bids which clarify, correct, or change the Bidding Requirements or the proposed Contract Documents.
  2. *Agreement*—The written instrument which is evidence of the agreement between Owner and Contractor covering the Work.
  3. *Application for Payment*—The form acceptable to Engineer which is to be used by Contractor during the course of the Work in requesting progress or final payments and which is to be accompanied by such supporting documentation as is required by the Contract Documents.
  4. *Asbestos*—Any material that contains more than one percent asbestos and is friable or is releasing asbestos fibers into the air above current action levels established by the United States Occupational Safety and Health Administration.
  5. *Bid*—The offer or proposal of a Bidder submitted on the prescribed form setting forth the prices for the Work to be performed.
  6. *Bidder*—The individual or entity who submits a Bid directly to Owner.
  7. *Bidding Documents*—The Bidding Requirements and the proposed Contract Documents (including all Addenda).
  8. *Bidding Requirements*—The advertisement or invitation to bid, Instructions to Bidders, Bid security of acceptable form, if any, and the Bid Form with any supplements.
  9. *Change Order*—A document recommended by Engineer which is signed by Contractor and Owner and authorizes an addition, deletion, or revision in the Work or an adjustment in the Contract Price or the Contract Times, issued on or after the Effective Date of the Agreement.
  10. *Claim*—A demand or assertion by Owner or Contractor seeking an adjustment of Contract Price or Contract Times, or both, or other relief with respect to the terms of the Contract. A demand for money or services by a third party is not a Claim.
  11. *Contract*—The entire and integrated written agreement between the Owner and Contractor concerning the Work. The Contract supersedes prior negotiations, representations, or agreements, whether written or oral.

12. *Contract Documents*—Those items so designated in the Agreement. Only printed or hard copies of the items listed in the Agreement are Contract Documents. Approved Shop Drawings, other Contractor submittals, and the reports and drawings of subsurface and physical conditions are not Contract Documents.
13. *Contract Price*—The moneys payable by Owner to Contractor for completion of the Work in accordance with the Contract Documents as stated in the Agreement (subject to the provisions of Paragraph 11.03 in the case of Unit Price Work).
14. *Contract Times*—The number of days or the dates stated in the Agreement to: (i) achieve Milestones, if any; (ii) achieve Substantial Completion; and (iii) complete the Work so that it is ready for final payment as evidenced by Engineer's written recommendation of final payment.
15. *Contractor*—The individual or entity with whom Owner has entered into the Agreement.
16. *Cost of the Work*—See Paragraph 11.01 for definition.
17. *Drawings*—That part of the Contract Documents prepared or approved by Engineer which graphically shows the scope, extent, and character of the Work to be performed by Contractor. Shop Drawings and other Contractor submittals are not Drawings as so defined.
18. *Effective Date of the Agreement*—The date indicated in the Agreement on which it becomes effective, but if no such date is indicated, it means the date on which the Agreement is signed and delivered by the last of the two parties to sign and deliver.
19. *Engineer*—The individual or entity named as such in the Agreement.
20. *Field Order*—A written order issued by Engineer which requires minor changes in the Work but which does not involve a change in the Contract Price or the Contract Times.
21. *General Requirements*—Sections of Division 1 of the Specifications.
22. *Hazardous Environmental Condition*—The presence at the Site of Asbestos, PCBs, Petroleum, Hazardous Waste, or Radioactive Material in such quantities or circumstances that may present a substantial danger to persons or property exposed thereto.
23. *Hazardous Waste*—The term Hazardous Waste shall have the meaning provided in Section 1004 of the Solid Waste Disposal Act (42 USC Section 6903) as amended from time to time.
24. *Laws and Regulations; Laws or Regulations*—Any and all applicable laws, rules, regulations, ordinances, codes, and orders of any and all governmental bodies, agencies, authorities, and courts having jurisdiction.
25. *Liens*—Charges, security interests, or encumbrances upon Project funds, real property, or personal property.
26. *Milestone*—A principal event specified in the Contract Documents relating to an intermediate completion date or time prior to Substantial Completion of all the Work.

27. *Notice of Award*—The written notice by Owner to the Successful Bidder stating that upon timely compliance by the Successful Bidder with the conditions precedent listed therein, Owner will sign and deliver the Agreement.
28. *Notice to Proceed*—A written notice given by Owner to Contractor fixing the date on which the Contract Times will commence to run and on which Contractor shall start to perform the Work under the Contract Documents.
29. *Owner*—The individual or entity with whom Contractor has entered into the Agreement and for whom the Work is to be performed.
30. *PCBs*—Polychlorinated biphenyls.
31. *Petroleum*—Petroleum, including crude oil or any fraction thereof which is liquid at standard conditions of temperature and pressure (60 degrees Fahrenheit and 14.7 pounds per square inch absolute), such as oil, petroleum, fuel oil, oil sludge, oil refuse, gasoline, kerosene, and oil mixed with other non-Hazardous Waste and crude oils.
32. *Progress Schedule*—A schedule, prepared and maintained by Contractor, describing the sequence and duration of the activities comprising the Contractor's plan to accomplish the Work within the Contract Times.
33. *Project*—The total construction of which the Work to be performed under the Contract Documents may be the whole, or a part.
34. *Project Manual*—The bound documentary information prepared for bidding and constructing the Work. A listing of the contents of the Project Manual, which may be bound in one or more volumes, is contained in the table(s) of contents.
35. *Radioactive Material*—Source, special nuclear, or byproduct material as defined by the Atomic Energy Act of 1954 (42 USC Section 2011 et seq.) as amended from time to time.
36. *Resident Project Representative*—The authorized representative of Engineer who may be assigned to the Site or any part thereof.
37. *Samples*—Physical examples of materials, equipment, or workmanship that are representative of some portion of the Work and which establish the standards by which such portion of the Work will be judged.
38. *Schedule of Submittals*—A schedule, prepared and maintained by Contractor, of required submittals and the time requirements to support scheduled performance of related construction activities.
39. *Schedule of Values*—A schedule, prepared and maintained by Contractor, allocating portions of the Contract Price to various portions of the Work and used as the basis for reviewing Contractor's Applications for Payment.

40. *Shop Drawings*—All drawings, diagrams, illustrations, schedules, and other data or information which are specifically prepared or assembled by or for Contractor and submitted by Contractor to illustrate some portion of the Work.
41. *Site*—Lands or areas indicated in the Contract Documents as being furnished by Owner upon which the Work is to be performed, including rights-of-way and easements for access thereto, and such other lands furnished by Owner which are designated for the use of Contractor.
42. *Specifications*—That part of the Contract Documents consisting of written requirements for materials, equipment, systems, standards and workmanship as applied to the Work, and certain administrative requirements and procedural matters applicable thereto.
43. *Subcontractor*—An individual or entity having a direct contract with Contractor or with any other Subcontractor for the performance of a part of the Work at the Site.
44. *Substantial Completion*—The time at which the Work (or a specified part thereof) has progressed to the point where, in the opinion of Engineer, the Work (or a specified part thereof) is sufficiently complete, in accordance with the Contract Documents, so that the Work (or a specified part thereof) can be utilized for the purposes for which it is intended. The terms “substantially complete” and “substantially completed” as applied to all or part of the Work refer to Substantial Completion thereof.
45. *Successful Bidder*—The Bidder submitting a responsive Bid to whom Owner makes an award.
46. *Supplementary Conditions*—That part of the Contract Documents which amends or supplements these General Conditions.
47. *Supplier*—A manufacturer, fabricator, supplier, distributor, materialman, or vendor having a direct contract with Contractor or with any Subcontractor to furnish materials or equipment to be incorporated in the Work by Contractor or Subcontractor.
48. *Underground Facilities*—All underground pipelines, conduits, ducts, cables, wires, manholes, vaults, tanks, tunnels, or other such facilities or attachments, and any encasements containing such facilities, including those that convey electricity, gases, steam, liquid petroleum products, telephone or other communications, cable television, water, wastewater, storm water, other liquids or chemicals, or traffic or other control systems.
49. *Unit Price Work*—Work to be paid for on the basis of unit prices.
50. *Work*—The entire construction or the various separately identifiable parts thereof required to be provided under the Contract Documents. Work includes and is the result of performing or providing all labor, services, and documentation necessary to produce such construction, and furnishing, installing, and incorporating all materials and equipment into such construction, all as required by the Contract Documents.

51. *Work Change Directive*—A written statement to Contractor issued on or after the Effective Date of the Agreement and signed by Owner and recommended by Engineer ordering an addition, deletion, or revision in the Work, or responding to differing or unforeseen subsurface or physical conditions under which the Work is to be performed or to emergencies. A Work Change Directive will not change the Contract Price or the Contract Times but is evidence that the parties expect that the change ordered or documented by a Work Change Directive will be incorporated in a subsequently issued Change Order following negotiations by the parties as to its effect, if any, on the Contract Price or Contract Times.

1.02 *Terminology*

A. The words and terms discussed in Paragraph 1.02.B through F are not defined but, when used in the Bidding Requirements or Contract Documents, have the indicated meaning.

B. *Intent of Certain Terms or Adjectives:*

1. The Contract Documents include the terms “as allowed,” “as approved,” “as ordered,” “as directed” or terms of like effect or import to authorize an exercise of professional judgment by Engineer. In addition, the adjectives “reasonable,” “suitable,” “acceptable,” “proper,” “satisfactory,” or adjectives of like effect or import are used to describe an action or determination of Engineer as to the Work. It is intended that such exercise of professional judgment, action, or determination will be solely to evaluate, in general, the Work for compliance with the information in the Contract Documents and with the design concept of the Project as a functioning whole as shown or indicated in the Contract Documents (unless there is a specific statement indicating otherwise). The use of any such term or adjective is not intended to and shall not be effective to assign to Engineer any duty or authority to supervise or direct the performance of the Work, or any duty or authority to undertake responsibility contrary to the provisions of Paragraph 9.09 or any other provision of the Contract Documents.

C. *Day:*

1. The word “day” means a calendar day of 24 hours measured from midnight to the next midnight.

D. *Defective:*

1. The word “defective,” when modifying the word “Work,” refers to Work that is unsatisfactory, faulty, or deficient in that it:

a. does not conform to the Contract Documents; or

b. does not meet the requirements of any applicable inspection, reference standard, test, or approval referred to in the Contract Documents; or

- c. has been damaged prior to Engineer's recommendation of final payment (unless responsibility for the protection thereof has been assumed by Owner at Substantial Completion in accordance with Paragraph 14.04 or 14.05).

E. *Furnish, Install, Perform, Provide:*

1. The word "furnish," when used in connection with services, materials, or equipment, shall mean to supply and deliver said services, materials, or equipment to the Site (or some other specified location) ready for use or installation and in usable or operable condition.
  2. The word "install," when used in connection with services, materials, or equipment, shall mean to put into use or place in final position said services, materials, or equipment complete and ready for intended use.
  3. The words "perform" or "provide," when used in connection with services, materials, or equipment, shall mean to furnish and install said services, materials, or equipment complete and ready for intended use.
  4. When "furnish," "install," "perform," or "provide" is not used in connection with services, materials, or equipment in a context clearly requiring an obligation of Contractor, "provide" is implied.
- F. Unless stated otherwise in the Contract Documents, words or phrases that have a well-known technical or construction industry or trade meaning are used in the Contract Documents in accordance with such recognized meaning.

## ARTICLE 2 – PRELIMINARY MATTERS

### 2.01 *Delivery of Bonds and Evidence of Insurance*

- A. When Contractor delivers the executed counterparts of the Agreement to Owner, Contractor shall also deliver to Owner such bonds as Contractor may be required to furnish.
- B. *Evidence of Insurance:* Before any Work at the Site is started, Contractor and Owner shall each deliver to the other, with copies to each additional insured identified in the Supplementary Conditions, certificates of insurance (and other evidence of insurance which either of them or any additional insured may reasonably request) which Contractor and Owner respectively are required to purchase and maintain in accordance with Article 5.

### 2.02 *Copies of Documents*

- A. Owner shall furnish to Contractor up to ten printed or hard copies of the Drawings and Project Manual. Additional copies will be furnished upon request at the cost of reproduction.

### 2.03 *Commencement of Contract Times; Notice to Proceed*

- A. The Contract Times will commence to run on the thirtieth day after the Effective Date of the Agreement or, if a Notice to Proceed is given, on the day indicated in the Notice to Proceed. A Notice to Proceed may be given at any time within 30 days after the Effective Date of the

Agreement. In no event will the Contract Times commence to run later than the sixtieth day after the day of Bid opening or the thirtieth day after the Effective Date of the Agreement, whichever date is earlier.

2.04 *Starting the Work*

- A. Contractor shall start to perform the Work on the date when the Contract Times commence to run. No Work shall be done at the Site prior to the date on which the Contract Times commence to run.

2.05 *Before Starting Construction*

- A. *Preliminary Schedules:* Within 10 days after the Effective Date of the Agreement (unless otherwise specified in the General Requirements), Contractor shall submit to Engineer for timely review:
  - 1. a preliminary Progress Schedule indicating the times (numbers of days or dates) for starting and completing the various stages of the Work, including any Milestones specified in the Contract Documents;
  - 2. a preliminary Schedule of Submittals; and
  - 3. a preliminary Schedule of Values for all of the Work which includes quantities and prices of items which when added together equal the Contract Price and subdivides the Work into component parts in sufficient detail to serve as the basis for progress payments during performance of the Work. Such prices will include an appropriate amount of overhead and profit applicable to each item of Work.

2.06 *Preconstruction Conference; Designation of Authorized Representatives*

- A. Before any Work at the Site is started, a conference attended by Owner, Contractor, Engineer, and others as appropriate will be held to establish a working understanding among the parties as to the Work and to discuss the schedules referred to in Paragraph 2.05.A, procedures for handling Shop Drawings and other submittals, processing Applications for Payment, and maintaining required records.
- B. At this conference Owner and Contractor each shall designate, in writing, a specific individual to act as its authorized representative with respect to the services and responsibilities under the Contract. Such individuals shall have the authority to transmit instructions, receive information, render decisions relative to the Contract, and otherwise act on behalf of each respective party.

2.07 *Initial Acceptance of Schedules*

- A. At least 10 days before submission of the first Application for Payment a conference attended by Contractor, Engineer, and others as appropriate will be held to review for acceptability to Engineer as provided below the schedules submitted in accordance with Paragraph 2.05.A. Contractor shall have an additional 10 days to make corrections and adjustments and to complete

and resubmit the schedules. No progress payment shall be made to Contractor until acceptable schedules are submitted to Engineer.

1. The Progress Schedule will be acceptable to Engineer if it provides an orderly progression of the Work to completion within the Contract Times. Such acceptance will not impose on Engineer responsibility for the Progress Schedule, for sequencing, scheduling, or progress of the Work, nor interfere with or relieve Contractor from Contractor's full responsibility therefor.
2. Contractor's Schedule of Submittals will be acceptable to Engineer if it provides a workable arrangement for reviewing and processing the required submittals.
3. Contractor's Schedule of Values will be acceptable to Engineer as to form and substance if it provides a reasonable allocation of the Contract Price to component parts of the Work.

### **ARTICLE 3 – CONTRACT DOCUMENTS: INTENT, AMENDING, REUSE**

#### **3.01 *Intent***

- A. The Contract Documents are complementary; what is required by one is as binding as if required by all.
- B. It is the intent of the Contract Documents to describe a functionally complete project (or part thereof) to be constructed in accordance with the Contract Documents. Any labor, documentation, services, materials, or equipment that reasonably may be inferred from the Contract Documents or from prevailing custom or trade usage as being required to produce the indicated result will be provided whether or not specifically called for, at no additional cost to Owner.
- C. Clarifications and interpretations of the Contract Documents shall be issued by Engineer as provided in Article 9.

#### **3.02 *Reference Standards***

- A. Standards, Specifications, Codes, Laws, and Regulations
  1. Reference to standards, specifications, manuals, or codes of any technical society, organization, or association, or to Laws or Regulations, whether such reference be specific or by implication, shall mean the standard, specification, manual, code, or Laws or Regulations in effect at the time of opening of Bids (or on the Effective Date of the Agreement if there were no Bids), except as may be otherwise specifically stated in the Contract Documents.
  2. No provision of any such standard, specification, manual, or code, or any instruction of a Supplier, shall be effective to change the duties or responsibilities of Owner, Contractor, or Engineer, or any of their subcontractors, consultants, agents, or employees, from those set forth in the Contract Documents. No such provision or instruction shall be effective to assign to Owner, Engineer, or any of their officers, directors, members, partners, employees, agents, consultants, or subcontractors, any duty or authority to supervise or direct the performance of



the Work or any duty or authority to undertake responsibility inconsistent with the provisions of the Contract Documents.

### 3.03 *Reporting and Resolving Discrepancies*

#### A. *Reporting Discrepancies:*

1. *Contractor's Review of Contract Documents Before Starting Work:* Before undertaking each part of the Work, Contractor shall carefully study and compare the Contract Documents and check and verify pertinent figures therein and all applicable field measurements. Contractor shall promptly report in writing to Engineer any conflict, error, ambiguity, or discrepancy which Contractor discovers, or has actual knowledge of, and shall obtain a written interpretation or clarification from Engineer before proceeding with any Work affected thereby.
2. *Contractor's Review of Contract Documents During Performance of Work:* If, during the performance of the Work, Contractor discovers any conflict, error, ambiguity, or discrepancy within the Contract Documents, or between the Contract Documents and (a) any applicable Law or Regulation, (b) any standard, specification, manual, or code, or (c) any instruction of any Supplier, then Contractor shall promptly report it to Engineer in writing. Contractor shall not proceed with the Work affected thereby (except in an emergency as required by Paragraph 6.16.A) until an amendment or supplement to the Contract Documents has been issued by one of the methods indicated in Paragraph 3.04.
3. Contractor shall not be liable to Owner or Engineer for failure to report any conflict, error, ambiguity, or discrepancy in the Contract Documents unless Contractor had actual knowledge thereof.

#### B. *Resolving Discrepancies:*

1. Except as may be otherwise specifically stated in the Contract Documents, the provisions of the Contract Documents shall take precedence in resolving any conflict, error, ambiguity, or discrepancy between the provisions of the Contract Documents and:
  - a. the provisions of any standard, specification, manual, or code, or the instruction of any Supplier (whether or not specifically incorporated by reference in the Contract Documents); or
  - b. the provisions of any Laws or Regulations applicable to the performance of the Work (unless such an interpretation of the provisions of the Contract Documents would result in violation of such Law or Regulation).

### 3.04 *Amending and Supplementing Contract Documents*

- A. The Contract Documents may be amended to provide for additions, deletions, and revisions in the Work or to modify the terms and conditions thereof by either a Change Order or a Work Change Directive.

B. The requirements of the Contract Documents may be supplemented, and minor variations and deviations in the Work may be authorized, by one or more of the following ways:

1. A Field Order;
2. Engineer's approval of a Shop Drawing or Sample (subject to the provisions of Paragraph 6.17.D.3); or
3. Engineer's written interpretation or clarification.

### 3.05 *Reuse of Documents*

A. Contractor and any Subcontractor or Supplier shall not:

1. have or acquire any title to or ownership rights in any of the Drawings, Specifications, or other documents (or copies of any thereof) prepared by or bearing the seal of Engineer or its consultants, including electronic media editions; or
2. reuse any such Drawings, Specifications, other documents, or copies thereof on extensions of the Project or any other project without written consent of Owner and Engineer and specific written verification or adaptation by Engineer.

B. The prohibitions of this Paragraph 3.05 will survive final payment, or termination of the Contract. Nothing herein shall preclude Contractor from retaining copies of the Contract Documents for record purposes.

### 3.06 *Electronic Data*

- A. Unless otherwise stated in the Supplementary Conditions, the data furnished by Owner or Engineer to Contractor, or by Contractor to Owner or Engineer, that may be relied upon are limited to the printed copies (also known as hard copies). Files in electronic media format of text, data, graphics, or other types are furnished only for the convenience of the receiving party. Any conclusion or information obtained or derived from such electronic files will be at the user's sole risk. If there is a discrepancy between the electronic files and the hard copies, the hard copies govern.
- B. Because data stored in electronic media format can deteriorate or be modified inadvertently or otherwise without authorization of the data's creator, the party receiving electronic files agrees that it will perform acceptance tests or procedures within 60 days, after which the receiving party shall be deemed to have accepted the data thus transferred. Any errors detected within the 60-day acceptance period will be corrected by the transferring party.
- C. When transferring documents in electronic media format, the transferring party makes no representations as to long term compatibility, usability, or readability of documents resulting from the use of software application packages, operating systems, or computer hardware differing from those used by the data's creator.

**ARTICLE 4 – AVAILABILITY OF LANDS; SUBSURFACE AND PHYSICAL CONDITIONS;  
HAZARDOUS ENVIRONMENTAL CONDITIONS; REFERENCE POINTS**

4.01 *Availability of Lands*

- A. Owner shall furnish the Site. Owner shall notify Contractor of any encumbrances or restrictions not of general application but specifically related to use of the Site with which Contractor must comply in performing the Work. Owner will obtain in a timely manner and pay for easements for permanent structures or permanent changes in existing facilities. If Contractor and Owner are unable to agree on entitlement to or on the amount or extent, if any, of any adjustment in the Contract Price or Contract Times, or both, as a result of any delay in Owner's furnishing the Site or a part thereof, Contractor may make a Claim therefor as provided in Paragraph 10.05.
- B. Upon reasonable written request, Owner shall furnish Contractor with a current statement of record legal title and legal description of the lands upon which the Work is to be performed and Owner's interest therein as necessary for giving notice of or filing a mechanic's or construction lien against such lands in accordance with applicable Laws and Regulations.
- C. Contractor shall provide for all additional lands and access thereto that may be required for temporary construction facilities or storage of materials and equipment.

4.02 *Subsurface and Physical Conditions*

- A. *Reports and Drawings:* The Supplementary Conditions identify:
  - 1. those reports known to Owner of explorations and tests of subsurface conditions at or contiguous to the Site; and
  - 2. those drawings known to Owner of physical conditions relating to existing surface or subsurface structures at the Site (except Underground Facilities).
- B. *Limited Reliance by Contractor on Technical Data Authorized:* Contractor may rely upon the accuracy of the "technical data" contained in such reports and drawings, but such reports and drawings are not Contract Documents. Such "technical data" is identified in the Supplementary Conditions. Except for such reliance on such "technical data," Contractor may not rely upon or make any claim against Owner or Engineer, or any of their officers, directors, members, partners, employees, agents, consultants, or subcontractors with respect to:
  - 1. the completeness of such reports and drawings for Contractor's purposes, including, but not limited to, any aspects of the means, methods, techniques, sequences, and procedures of construction to be employed by Contractor, and safety precautions and programs incident thereto; or
  - 2. other data, interpretations, opinions, and information contained in such reports or shown or indicated in such drawings; or
  - 3. any Contractor interpretation of or conclusion drawn from any "technical data" or any such other data, interpretations, opinions, or information.

#### 4.03 *Differing Subsurface or Physical Conditions*

A. *Notice:* If Contractor believes that any subsurface or physical condition that is uncovered or revealed either:

1. is of such a nature as to establish that any "technical data" on which Contractor is entitled to rely as provided in Paragraph 4.02 is materially inaccurate; or
2. is of such a nature as to require a change in the Contract Documents; or
3. differs materially from that shown or indicated in the Contract Documents; or
4. is of an unusual nature, and differs materially from conditions ordinarily encountered and generally recognized as inherent in work of the character provided for in the Contract Documents;

then Contractor shall, promptly after becoming aware thereof and before further disturbing the subsurface or physical conditions or performing any Work in connection therewith (except in an emergency as required by Paragraph 6.16.A), notify Owner and Engineer in writing about such condition. Contractor shall not further disturb such condition or perform any Work in connection therewith (except as aforesaid) until receipt of written order to do so.

B. *Engineer's Review:* After receipt of written notice as required by Paragraph 4.03.A, Engineer will promptly review the pertinent condition, determine the necessity of Owner's obtaining additional exploration or tests with respect thereto, and advise Owner in writing (with a copy to Contractor) of Engineer's findings and conclusions.

C. *Possible Price and Times Adjustments:*

1. The Contract Price or the Contract Times, or both, will be equitably adjusted to the extent that the existence of such differing subsurface or physical condition causes an increase or decrease in Contractor's cost of, or time required for, performance of the Work; subject, however, to the following:
  - a. such condition must meet any one or more of the categories described in Paragraph 4.03.A; and
  - b. with respect to Work that is paid for on a unit price basis, any adjustment in Contract Price will be subject to the provisions of Paragraphs 9.07 and 11.03.
2. Contractor shall not be entitled to any adjustment in the Contract Price or Contract Times if:
  - a. Contractor knew of the existence of such conditions at the time Contractor made a final commitment to Owner with respect to Contract Price and Contract Times by the submission of a Bid or becoming bound under a negotiated contract; or
  - b. the existence of such condition could reasonably have been discovered or revealed as a result of any examination, investigation, exploration, test, or study of the Site and

contiguous areas required by the Bidding Requirements or Contract Documents to be conducted by or for Contractor prior to Contractor's making such final commitment; or

- c. Contractor failed to give the written notice as required by Paragraph 4.03.A.
3. If Owner and Contractor are unable to agree on entitlement to or on the amount or extent, if any, of any adjustment in the Contract Price or Contract Times, or both, a Claim may be made therefor as provided in Paragraph 10.05. However, neither Owner or Engineer, or any of their officers, directors, members, partners, employees, agents, consultants, or subcontractors shall be liable to Contractor for any claims, costs, losses, or damages (including but not limited to all fees and charges of engineers, architects, attorneys, and other professionals and all court or arbitration or other dispute resolution costs) sustained by Contractor on or in connection with any other project or anticipated project.

#### 4.04 *Underground Facilities*

A. *Shown or Indicated:* The information and data shown or indicated in the Contract Documents with respect to existing Underground Facilities at or contiguous to the Site is based on information and data furnished to Owner or Engineer by the owners of such Underground Facilities, including Owner, or by others. Unless it is otherwise expressly provided in the Supplementary Conditions:

1. Owner and Engineer shall not be responsible for the accuracy or completeness of any such information or data provided by others; and
2. the cost of all of the following will be included in the Contract Price, and Contractor shall have full responsibility for:
  - a. reviewing and checking all such information and data;
  - b. locating all Underground Facilities shown or indicated in the Contract Documents;
  - c. coordination of the Work with the owners of such Underground Facilities, including Owner, during construction; and
  - d. the safety and protection of all such Underground Facilities and repairing any damage thereto resulting from the Work.

B. *Not Shown or Indicated:*

1. If an Underground Facility is uncovered or revealed at or contiguous to the Site which was not shown or indicated, or not shown or indicated with reasonable accuracy in the Contract Documents, Contractor shall, promptly after becoming aware thereof and before further disturbing conditions affected thereby or performing any Work in connection therewith (except in an emergency as required by Paragraph 6.16.A), identify the owner of such Underground Facility and give written notice to that owner and to Owner and Engineer. Engineer will promptly review the Underground Facility and determine the extent, if any, to which a change is required in the Contract Documents to reflect and document the

consequences of the existence or location of the Underground Facility. During such time, Contractor shall be responsible for the safety and protection of such Underground Facility.

2. If Engineer concludes that a change in the Contract Documents is required, a Work Change Directive or a Change Order will be issued to reflect and document such consequences. An equitable adjustment shall be made in the Contract Price or Contract Times, or both, to the extent that they are attributable to the existence or location of any Underground Facility that was not shown or indicated or not shown or indicated with reasonable accuracy in the Contract Documents and that Contractor did not know of and could not reasonably have been expected to be aware of or to have anticipated. If Owner and Contractor are unable to agree on entitlement to or on the amount or extent, if any, of any such adjustment in Contract Price or Contract Times, Owner or Contractor may make a Claim therefor as provided in Paragraph 10.05.

#### 4.05 *Reference Points*

- A. Owner shall provide engineering surveys to establish reference points for construction which in Engineer's judgment are necessary to enable Contractor to proceed with the Work. Contractor shall be responsible for laying out the Work, shall protect and preserve the established reference points and property monuments, and shall make no changes or relocations without the prior written approval of Owner. Contractor shall report to Engineer whenever any reference point or property monument is lost or destroyed or requires relocation because of necessary changes in grades or locations, and shall be responsible for the accurate replacement or relocation of such reference points or property monuments by professionally qualified personnel.

#### 4.06 *Hazardous Environmental Condition at Site*

- A. *Reports and Drawings:* The Supplementary Conditions identify those reports and drawings known to Owner relating to Hazardous Environmental Conditions that have been identified at the Site.
- B. *Limited Reliance by Contractor on Technical Data Authorized:* Contractor may rely upon the accuracy of the "technical data" contained in such reports and drawings, but such reports and drawings are not Contract Documents. Such "technical data" is identified in the Supplementary Conditions. Except for such reliance on such "technical data," Contractor may not rely upon or make any claim against Owner or Engineer, or any of their officers, directors, members, partners, employees, agents, consultants, or subcontractors with respect to:
  1. the completeness of such reports and drawings for Contractor's purposes, including, but not limited to, any aspects of the means, methods, techniques, sequences and procedures of construction to be employed by Contractor and safety precautions and programs incident thereto; or
  2. other data, interpretations, opinions and information contained in such reports or shown or indicated in such drawings; or
  3. any Contractor interpretation of or conclusion drawn from any "technical data" or any such other data, interpretations, opinions or information.

- C. Contractor shall not be responsible for any Hazardous Environmental Condition uncovered or revealed at the Site which was not shown or indicated in Drawings or Specifications or identified in the Contract Documents to be within the scope of the Work. Contractor shall be responsible for a Hazardous Environmental Condition created with any materials brought to the Site by Contractor, Subcontractors, Suppliers, or anyone else for whom Contractor is responsible.
- D. If Contractor encounters a Hazardous Environmental Condition or if Contractor or anyone for whom Contractor is responsible creates a Hazardous Environmental Condition, Contractor shall immediately: (i) secure or otherwise isolate such condition; (ii) stop all Work in connection with such condition and in any area affected thereby (except in an emergency as required by Paragraph 6.16.A); and (iii) notify Owner and Engineer (and promptly thereafter confirm such notice in writing). Owner shall promptly consult with Engineer concerning the necessity for Owner to retain a qualified expert to evaluate such condition or take corrective action, if any. Promptly after consulting with Engineer, Owner shall take such actions as are necessary to permit Owner to timely obtain required permits and provide Contractor the written notice required by Paragraph 4.06.E.
- E. Contractor shall not be required to resume Work in connection with such condition or in any affected area until after Owner has obtained any required permits related thereto and delivered written notice to Contractor: (i) specifying that such condition and any affected area is or has been rendered safe for the resumption of Work; or (ii) specifying any special conditions under which such Work may be resumed safely. If Owner and Contractor cannot agree as to entitlement to or on the amount or extent, if any, of any adjustment in Contract Price or Contract Times, or both, as a result of such Work stoppage or such special conditions under which Work is agreed to be resumed by Contractor, either party may make a Claim therefor as provided in Paragraph 10.05.
- F. If after receipt of such written notice Contractor does not agree to resume such Work based on a reasonable belief it is unsafe, or does not agree to resume such Work under such special conditions, then Owner may order the portion of the Work that is in the area affected by such condition to be deleted from the Work. If Owner and Contractor cannot agree as to entitlement to or on the amount or extent, if any, of an adjustment in Contract Price or Contract Times as a result of deleting such portion of the Work, then either party may make a Claim therefor as provided in Paragraph 10.05. Owner may have such deleted portion of the Work performed by Owner's own forces or others in accordance with Article 7.
- G. To the fullest extent permitted by Laws and Regulations, Owner shall indemnify and hold harmless Contractor, Subcontractors, and Engineer, and the officers, directors, members, partners, employees, agents, consultants, and subcontractors of each and any of them from and against all claims, costs, losses, and damages (including but not limited to all fees and charges of engineers, architects, attorneys, and other professionals and all court or arbitration or other dispute resolution costs) arising out of or relating to a Hazardous Environmental Condition, provided that such Hazardous Environmental Condition: (i) was not shown or indicated in the Drawings or Specifications or identified in the Contract Documents to be included within the scope of the Work, and (ii) was not created by Contractor or by anyone for whom Contractor is responsible. Nothing in this Paragraph 4.06.G shall obligate Owner to indemnify any individual or entity from and against the consequences of that individual's or entity's own negligence.

- H. To the fullest extent permitted by Laws and Regulations, Contractor shall indemnify and hold harmless Owner and Engineer, and the officers, directors, members, partners, employees, agents, consultants, and subcontractors of each and any of them from and against all claims, costs, losses, and damages (including but not limited to all fees and charges of engineers, architects, attorneys, and other professionals and all court or arbitration or other dispute resolution costs) arising out of or relating to a Hazardous Environmental Condition created by Contractor or by anyone for whom Contractor is responsible. Nothing in this Paragraph 4.06.H shall obligate Contractor to indemnify any individual or entity from and against the consequences of that individual's or entity's own negligence.
- I. The provisions of Paragraphs 4.02, 4.03, and 4.04 do not apply to a Hazardous Environmental Condition uncovered or revealed at the Site.

## ARTICLE 5 – BONDS AND INSURANCE

### 5.01 *Performance, Payment, and Other Bonds*

- A. Contractor shall furnish performance and payment bonds, each in an amount at least equal to the Contract Price as security for the faithful performance and payment of all of Contractor's obligations under the Contract Documents. These bonds shall remain in effect until one year after the date when final payment becomes due or until completion of the correction period specified in Paragraph 13.07, whichever is later, except as provided otherwise by Laws or Regulations or by the Contract Documents. Contractor shall also furnish such other bonds as are required by the Contract Documents.
- B. All bonds shall be in the form prescribed by the Contract Documents except as provided otherwise by Laws or Regulations, and shall be executed by such sureties as are named in the list of "Companies Holding Certificates of Authority as Acceptable Sureties on Federal Bonds and as Acceptable Reinsuring Companies" as published in Circular 570 (amended) by the Financial Management Service, Surety Bond Branch, U.S. Department of the Treasury. All bonds signed by an agent or attorney-in-fact must be accompanied by a certified copy of that individual's authority to bind the surety. The evidence of authority shall show that it is effective on the date the agent or attorney-in-fact signed each bond.
- C. If the surety on any bond furnished by Contractor is declared bankrupt or becomes insolvent or its right to do business is terminated in any state where any part of the Project is located or it ceases to meet the requirements of Paragraph 5.01.B, Contractor shall promptly notify Owner and Engineer and shall, within 20 days after the event giving rise to such notification, provide another bond and surety, both of which shall comply with the requirements of Paragraphs 5.01.B and 5.02.

### 5.02 *Licensed Sureties and Insurers*

- A. All bonds and insurance required by the Contract Documents to be purchased and maintained by Owner or Contractor shall be obtained from surety or insurance companies that are duly licensed or authorized in the jurisdiction in which the Project is located to issue bonds or insurance policies for the limits and coverages so required. Such surety and insurance companies shall also



meet such additional requirements and qualifications as may be provided in the Supplementary Conditions.

### 5.03 *Certificates of Insurance*

- A. Contractor shall deliver to Owner, with copies to each additional insured and loss payee identified in the Supplementary Conditions, certificates of insurance (and other evidence of insurance requested by Owner or any other additional insured) which Contractor is required to purchase and maintain.
- B. Owner shall deliver to Contractor, with copies to each additional insured and loss payee identified in the Supplementary Conditions, certificates of insurance (and other evidence of insurance requested by Contractor or any other additional insured) which Owner is required to purchase and maintain.
- C. Failure of Owner to demand such certificates or other evidence of Contractor's full compliance with these insurance requirements or failure of Owner to identify a deficiency in compliance from the evidence provided shall not be construed as a waiver of Contractor's obligation to maintain such insurance.
- D. Owner does not represent that insurance coverage and limits established in this Contract necessarily will be adequate to protect Contractor.
- E. The insurance and insurance limits required herein shall not be deemed as a limitation on Contractor's liability under the indemnities granted to Owner in the Contract Documents.

### 5.04 *Contractor's Insurance*

- A. Contractor shall purchase and maintain such insurance as is appropriate for the Work being performed and as will provide protection from claims set forth below which may arise out of or result from Contractor's performance of the Work and Contractor's other obligations under the Contract Documents, whether it is to be performed by Contractor, any Subcontractor or Supplier, or by anyone directly or indirectly employed by any of them to perform any of the Work, or by anyone for whose acts any of them may be liable:
  - 1. claims under workers' compensation, disability benefits, and other similar employee benefit acts;
  - 2. claims for damages because of bodily injury, occupational sickness or disease, or death of Contractor's employees;
  - 3. claims for damages because of bodily injury, sickness or disease, or death of any person other than Contractor's employees;
  - 4. claims for damages insured by reasonably available personal injury liability coverage which are sustained:

- a. by any person as a result of an offense directly or indirectly related to the employment of such person by Contractor, or
  - b. by any other person for any other reason;
5. claims for damages, other than to the Work itself, because of injury to or destruction of tangible property wherever located, including loss of use resulting therefrom; and
  6. claims for damages because of bodily injury or death of any person or property damage arising out of the ownership, maintenance or use of any motor vehicle.

B. The policies of insurance required by this Paragraph 5.04 shall:

1. with respect to insurance required by Paragraphs 5.04.A.3 through 5.04.A.6 inclusive, be written on an occurrence basis, include as additional insureds (subject to any customary exclusion regarding professional liability) Owner and Engineer, and any other individuals or entities identified in the Supplementary Conditions, all of whom shall be listed as additional insureds, and include coverage for the respective officers, directors, members, partners, employees, agents, consultants, and subcontractors of each and any of all such additional insureds, and the insurance afforded to these additional insureds shall provide primary coverage for all claims covered thereby;
2. include at least the specific coverages and be written for not less than the limits of liability provided in the Supplementary Conditions or required by Laws or Regulations, whichever is greater;
3. include contractual liability insurance covering Contractor's indemnity obligations under Paragraphs 6.11 and 6.20;
4. contain a provision or endorsement that the coverage afforded will not be canceled, materially changed or renewal refused until at least 30 days prior written notice has been given to Owner and Contractor and to each other additional insured identified in the Supplementary Conditions to whom a certificate of insurance has been issued (and the certificates of insurance furnished by the Contractor pursuant to Paragraph 5.03 will so provide);
5. remain in effect at least until final payment and at all times thereafter when Contractor may be correcting, removing, or replacing defective Work in accordance with Paragraph 13.07; and
6. include completed operations coverage:
  - a. Such insurance shall remain in effect for two years after final payment.
  - b. Contractor shall furnish Owner and each other additional insured identified in the Supplementary Conditions, to whom a certificate of insurance has been issued, evidence satisfactory to Owner and any such additional insured of continuation of such insurance at final payment and one year thereafter.

5.05 *Owner's Liability Insurance*

- A. In addition to the insurance required to be provided by Contractor under Paragraph 5.04, Owner, at Owner's option, may purchase and maintain at Owner's expense Owner's own liability insurance as will protect Owner against claims which may arise from operations under the Contract Documents.

5.06 *Property Insurance*

- A. Unless otherwise provided in the Supplementary Conditions, Owner shall purchase and maintain property insurance upon the Work at the Site in the amount of the full replacement cost thereof (subject to such deductible amounts as may be provided in the Supplementary Conditions or required by Laws and Regulations). This insurance shall:
1. include the interests of Owner, Contractor, Subcontractors, and Engineer, and any other individuals or entities identified in the Supplementary Conditions, and the officers, directors, members, partners, employees, agents, consultants, and subcontractors of each and any of them, each of whom is deemed to have an insurable interest and shall be listed as a loss payee;
  2. be written on a Builder's Risk "all-risk" policy form that shall at least include insurance for physical loss or damage to the Work, temporary buildings, falsework, and materials and equipment in transit, and shall insure against at least the following perils or causes of loss: fire, lightning, extended coverage, theft, vandalism and malicious mischief, earthquake, collapse, debris removal, demolition occasioned by enforcement of Laws and Regulations, water damage (other than that caused by flood), and such other perils or causes of loss as may be specifically required by the Supplementary Conditions.
  3. include expenses incurred in the repair or replacement of any insured property (including but not limited to fees and charges of engineers and architects);
  4. cover materials and equipment stored at the Site or at another location that was agreed to in writing by Owner prior to being incorporated in the Work, provided that such materials and equipment have been included in an Application for Payment recommended by Engineer;
  5. allow for partial utilization of the Work by Owner;
  6. include testing and startup; and
  7. be maintained in effect until final payment is made unless otherwise agreed to in writing by Owner, Contractor, and Engineer with 30 days written notice to each other loss payee to whom a certificate of insurance has been issued.
- B. Owner shall purchase and maintain such equipment breakdown insurance or additional property insurance as may be required by the Supplementary Conditions or Laws and Regulations which will include the interests of Owner, Contractor, Subcontractors, and Engineer, and any other individuals or entities identified in the Supplementary Conditions, and the officers, directors,

members, partners, employees, agents, consultants and subcontractors of each and any of them, each of whom is deemed to have an insurable interest and shall be listed as a loss payee.

- C. All the policies of insurance (and the certificates or other evidence thereof) required to be purchased and maintained in accordance with this Paragraph 5.06 will contain a provision or endorsement that the coverage afforded will not be canceled or materially changed or renewal refused until at least 30 days prior written notice has been given to Owner and Contractor and to each other loss payee to whom a certificate of insurance has been issued and will contain waiver provisions in accordance with Paragraph 5.07.
- D. Owner shall not be responsible for purchasing and maintaining any property insurance specified in this Paragraph 5.06 to protect the interests of Contractor, Subcontractors, or others in the Work to the extent of any deductible amounts that are identified in the Supplementary Conditions. The risk of loss within such identified deductible amount will be borne by Contractor, Subcontractors, or others suffering any such loss, and if any of them wishes property insurance coverage within the limits of such amounts, each may purchase and maintain it at the purchaser's own expense.
- E. If Contractor requests in writing that other special insurance be included in the property insurance policies provided under this Paragraph 5.06, Owner shall, if possible, include such insurance, and the cost thereof will be charged to Contractor by appropriate Change Order. Prior to commencement of the Work at the Site, Owner shall in writing advise Contractor whether or not such other insurance has been procured by Owner.

#### 5.07 *Waiver of Rights*

- A. Owner and Contractor intend that all policies purchased in accordance with Paragraph 5.06 will protect Owner, Contractor, Subcontractors, and Engineer, and all other individuals or entities identified in the Supplementary Conditions as loss payees (and the officers, directors, members, partners, employees, agents, consultants, and subcontractors of each and any of them) in such policies and will provide primary coverage for all losses and damages caused by the perils or causes of loss covered thereby. All such policies shall contain provisions to the effect that in the event of payment of any loss or damage the insurers will have no rights of recovery against any of the insureds or loss payees thereunder. Owner and Contractor waive all rights against each other and their respective officers, directors, members, partners, employees, agents, consultants and subcontractors of each and any of them for all losses and damages caused by, arising out of or resulting from any of the perils or causes of loss covered by such policies and any other property insurance applicable to the Work; and, in addition, waive all such rights against Subcontractors and Engineer, and all other individuals or entities identified in the Supplementary Conditions as loss payees (and the officers, directors, members, partners, employees, agents, consultants, and subcontractors of each and any of them) under such policies for losses and damages so caused. None of the above waivers shall extend to the rights that any party making such waiver may have to the proceeds of insurance held by Owner as trustee or otherwise payable under any policy so issued.
- B. Owner waives all rights against Contractor, Subcontractors, and Engineer, and the officers, directors, members, partners, employees, agents, consultants and subcontractors of each and any of them for:

1. loss due to business interruption, loss of use, or other consequential loss extending beyond direct physical loss or damage to Owner's property or the Work caused by, arising out of, or resulting from fire or other perils whether or not insured by Owner; and
  2. loss or damage to the completed Project or part thereof caused by, arising out of, or resulting from fire or other insured peril or cause of loss covered by any property insurance maintained on the completed Project or part thereof by Owner during partial utilization pursuant to Paragraph 14.05, after Substantial Completion pursuant to Paragraph 14.04, or after final payment pursuant to Paragraph 14.07.
- C. Any insurance policy maintained by Owner covering any loss, damage or consequential loss referred to in Paragraph 5.07.B shall contain provisions to the effect that in the event of payment of any such loss, damage, or consequential loss, the insurers will have no rights of recovery against Contractor, Subcontractors, or Engineer, and the officers, directors, members, partners, employees, agents, consultants and subcontractors of each and any of them.

5.08 *Receipt and Application of Insurance Proceeds*

- A. Any insured loss under the policies of insurance required by Paragraph 5.06 will be adjusted with Owner and made payable to Owner as fiduciary for the loss payees, as their interests may appear, subject to the requirements of any applicable mortgage clause and of Paragraph 5.08.B. Owner shall deposit in a separate account any money so received and shall distribute it in accordance with such agreement as the parties in interest may reach. If no other special agreement is reached, the damaged Work shall be repaired or replaced, the moneys so received applied on account thereof, and the Work and the cost thereof covered by an appropriate Change Order.
- B. Owner as fiduciary shall have power to adjust and settle any loss with the insurers unless one of the parties in interest shall object in writing within 15 days after the occurrence of loss to Owner's exercise of this power. If such objection be made, Owner as fiduciary shall make settlement with the insurers in accordance with such agreement as the parties in interest may reach. If no such agreement among the parties in interest is reached, Owner as fiduciary shall adjust and settle the loss with the insurers and, if required in writing by any party in interest, Owner as fiduciary shall give bond for the proper performance of such duties.

5.09 *Acceptance of Bonds and Insurance; Option to Replace*

- A. If either Owner or Contractor has any objection to the coverage afforded by or other provisions of the bonds or insurance required to be purchased and maintained by the other party in accordance with Article 5 on the basis of non-conformance with the Contract Documents, the objecting party shall so notify the other party in writing within 10 days after receipt of the certificates (or other evidence requested) required by Paragraph 2.01.B. Owner and Contractor shall each provide to the other such additional information in respect of insurance provided as the other may reasonably request. If either party does not purchase or maintain all of the bonds and insurance required of such party by the Contract Documents, such party shall notify the other party in writing of such failure to purchase prior to the start of the Work, or of such failure to maintain prior to any change in the required coverage. Without prejudice to any other right or remedy, the other party may elect to obtain equivalent bonds or insurance to protect such other party's

interests at the expense of the party who was required to provide such coverage, and a Change Order shall be issued to adjust the Contract Price accordingly.

5.10 *Partial Utilization, Acknowledgment of Property Insurer*

- A. If Owner finds it necessary to occupy or use a portion or portions of the Work prior to Substantial Completion of all the Work as provided in Paragraph 14.05, no such use or occupancy shall commence before the insurers providing the property insurance pursuant to Paragraph 5.06 have acknowledged notice thereof and in writing effected any changes in coverage necessitated thereby. The insurers providing the property insurance shall consent by endorsement on the policy or policies, but the property insurance shall not be canceled or permitted to lapse on account of any such partial use or occupancy.

**ARTICLE 6 – CONTRACTOR’S RESPONSIBILITIES**

6.01 *Supervision and Superintendence*

- A. Contractor shall supervise, inspect, and direct the Work competently and efficiently, devoting such attention thereto and applying such skills and expertise as may be necessary to perform the Work in accordance with the Contract Documents. Contractor shall be solely responsible for the means, methods, techniques, sequences, and procedures of construction. Contractor shall not be responsible for the negligence of Owner or Engineer in the design or specification of a specific means, method, technique, sequence, or procedure of construction which is shown or indicated in and expressly required by the Contract Documents.
- B. At all times during the progress of the Work, Contractor shall assign a competent resident superintendent who shall not be replaced without written notice to Owner and Engineer except under extraordinary circumstances.

6.02 *Labor; Working Hours*

- A. Contractor shall provide competent, suitably qualified personnel to survey and lay out the Work and perform construction as required by the Contract Documents. Contractor shall at all times maintain good discipline and order at the Site.
- B. Except as otherwise required for the safety or protection of persons or the Work or property at the Site or adjacent thereto, and except as otherwise stated in the Contract Documents, all Work at the Site shall be performed during regular working hours. Contractor will not permit the performance of Work on a Saturday, Sunday, or any legal holiday without Owner’s written consent (which will not be unreasonably withheld) given after prior written notice to Engineer.

6.03 *Services, Materials, and Equipment*

- A. Unless otherwise specified in the Contract Documents, Contractor shall provide and assume full responsibility for all services, materials, equipment, labor, transportation, construction equipment and machinery, tools, appliances, fuel, power, light, heat, telephone, water, sanitary facilities, temporary facilities, and all other facilities and incidentals necessary for the performance, testing, start-up, and completion of the Work.

- B. All materials and equipment incorporated into the Work shall be as specified or, if not specified, shall be of good quality and new, except as otherwise provided in the Contract Documents. All special warranties and guarantees required by the Specifications shall expressly run to the benefit of Owner. If required by Engineer, Contractor shall furnish satisfactory evidence (including reports of required tests) as to the source, kind, and quality of materials and equipment.
- C. All materials and equipment shall be stored, applied, installed, connected, erected, protected, used, cleaned, and conditioned in accordance with instructions of the applicable Supplier, except as otherwise may be provided in the Contract Documents.

#### 6.04 *Progress Schedule*

- A. Contractor shall adhere to the Progress Schedule established in accordance with Paragraph 2.07 as it may be adjusted from time to time as provided below.
  - 1. Contractor shall submit to Engineer for acceptance (to the extent indicated in Paragraph 2.07) proposed adjustments in the Progress Schedule that will not result in changing the Contract Times. Such adjustments will comply with any provisions of the General Requirements applicable thereto.
  - 2. Proposed adjustments in the Progress Schedule that will change the Contract Times shall be submitted in accordance with the requirements of Article 12. Adjustments in Contract Times may only be made by a Change Order.

#### 6.05 *Substitutes and "Or-Equals"*

- A. Whenever an item of material or equipment is specified or described in the Contract Documents by using the name of a proprietary item or the name of a particular Supplier, the specification or description is intended to establish the type, function, appearance, and quality required. Unless the specification or description contains or is followed by words reading that no like, equivalent, or "or-equal" item or no substitution is permitted, other items of material or equipment or material or equipment of other Suppliers may be submitted to Engineer for review under the circumstances described below.
  - 1. "*Or-Equal*" Items: If in Engineer's sole discretion an item of material or equipment proposed by Contractor is functionally equal to that named and sufficiently similar so that no change in related Work will be required, it may be considered by Engineer as an "or-equal" item, in which case review and approval of the proposed item may, in Engineer's sole discretion, be accomplished without compliance with some or all of the requirements for approval of proposed substitute items. For the purposes of this Paragraph 6.05.A.1, a proposed item of material or equipment will be considered functionally equal to an item so named if:
    - a. in the exercise of reasonable judgment Engineer determines that:
      - 1) it is at least equal in materials of construction, quality, durability, appearance, strength, and design characteristics;

- 2) it will reliably perform at least equally well the function and achieve the results imposed by the design concept of the completed Project as a functioning whole; and
  - 3) it has a proven record of performance and availability of responsive service.
- b. Contractor certifies that, if approved and incorporated into the Work:
- 1) there will be no increase in cost to the Owner or increase in Contract Times; and
  - 2) it will conform substantially to the detailed requirements of the item named in the Contract Documents.

2. *Substitute Items:*

- a. If in Engineer's sole discretion an item of material or equipment proposed by Contractor does not qualify as an "or-equal" item under Paragraph 6.05.A.1, it will be considered a proposed substitute item.
- b. Contractor shall submit sufficient information as provided below to allow Engineer to determine if the item of material or equipment proposed is essentially equivalent to that named and an acceptable substitute therefor. Requests for review of proposed substitute items of material or equipment will not be accepted by Engineer from anyone other than Contractor.
- c. The requirements for review by Engineer will be as set forth in Paragraph 6.05.A.2.d, as supplemented by the General Requirements, and as Engineer may decide is appropriate under the circumstances.
- d. Contractor shall make written application to Engineer for review of a proposed substitute item of material or equipment that Contractor seeks to furnish or use. The application:
  - 1) shall certify that the proposed substitute item will:
    - a) perform adequately the functions and achieve the results called for by the general design,
    - b) be similar in substance to that specified, and
    - c) be suited to the same use as that specified;
  - 2) will state:
    - a) the extent, if any, to which the use of the proposed substitute item will prejudice Contractor's achievement of Substantial Completion on time,
    - b) whether use of the proposed substitute item in the Work will require a change in any of the Contract Documents (or in the provisions of any other direct contract with Owner for other work on the Project) to adapt the design to the proposed substitute item, and



- c) whether incorporation or use of the proposed substitute item in connection with the Work is subject to payment of any license fee or royalty;
  - 3) will identify:
    - a) all variations of the proposed substitute item from that specified, and
    - b) available engineering, sales, maintenance, repair, and replacement services; and
  - 4) shall contain an itemized estimate of all costs or credits that will result directly or indirectly from use of such substitute item, including costs of redesign and claims of other contractors affected by any resulting change.
- B. *Substitute Construction Methods or Procedures:* If a specific means, method, technique, sequence, or procedure of construction is expressly required by the Contract Documents, Contractor may furnish or utilize a substitute means, method, technique, sequence, or procedure of construction approved by Engineer. Contractor shall submit sufficient information to allow Engineer, in Engineer's sole discretion, to determine that the substitute proposed is equivalent to that expressly called for by the Contract Documents. The requirements for review by Engineer will be similar to those provided in Paragraph 6.05.A.2.
- C. *Engineer's Evaluation:* Engineer will be allowed a reasonable time within which to evaluate each proposal or submittal made pursuant to Paragraphs 6.05.A and 6.05.B. Engineer may require Contractor to furnish additional data about the proposed substitute item. Engineer will be the sole judge of acceptability. No "or equal" or substitute will be ordered, installed or utilized until Engineer's review is complete, which will be evidenced by a Change Order in the case of a substitute and an approved Shop Drawing for an "or equal." Engineer will advise Contractor in writing of any negative determination.
- D. *Special Guarantee:* Owner may require Contractor to furnish at Contractor's expense a special performance guarantee or other surety with respect to any substitute.
- E. *Engineer's Cost Reimbursement:* Engineer will record Engineer's costs in evaluating a substitute proposed or submitted by Contractor pursuant to Paragraphs 6.05.A.2 and 6.05.B. Whether or not Engineer approves a substitute so proposed or submitted by Contractor, Contractor shall reimburse Owner for the reasonable charges of Engineer for evaluating each such proposed substitute. Contractor shall also reimburse Owner for the reasonable charges of Engineer for making changes in the Contract Documents (or in the provisions of any other direct contract with Owner) resulting from the acceptance of each proposed substitute.
- F. *Contractor's Expense:* Contractor shall provide all data in support of any proposed substitute or "or-equal" at Contractor's expense.

#### 6.06 *Concerning Subcontractors, Suppliers, and Others*

- A. Contractor shall not employ any Subcontractor, Supplier, or other individual or entity (including those acceptable to Owner as indicated in Paragraph 6.06.B), whether initially or as a replacement, against whom Owner may have reasonable objection. Contractor shall not be

required to employ any Subcontractor, Supplier, or other individual or entity to furnish or perform any of the Work against whom Contractor has reasonable objection.

- B. If the Supplementary Conditions require the identity of certain Subcontractors, Suppliers, or other individuals or entities to be submitted to Owner in advance for acceptance by Owner by a specified date prior to the Effective Date of the Agreement, and if Contractor has submitted a list thereof in accordance with the Supplementary Conditions, Owner's acceptance (either in writing or by failing to make written objection thereto by the date indicated for acceptance or objection in the Bidding Documents or the Contract Documents) of any such Subcontractor, Supplier, or other individual or entity so identified may be revoked on the basis of reasonable objection after due investigation. Contractor shall submit an acceptable replacement for the rejected Subcontractor, Supplier, or other individual or entity, and the Contract Price will be adjusted by the difference in the cost occasioned by such replacement, and an appropriate Change Order will be issued. No acceptance by Owner of any such Subcontractor, Supplier, or other individual or entity, whether initially or as a replacement, shall constitute a waiver of any right of Owner or Engineer to reject defective Work.
- C. Contractor shall be fully responsible to Owner and Engineer for all acts and omissions of the Subcontractors, Suppliers, and other individuals or entities performing or furnishing any of the Work just as Contractor is responsible for Contractor's own acts and omissions. Nothing in the Contract Documents:
1. shall create for the benefit of any such Subcontractor, Supplier, or other individual or entity any contractual relationship between Owner or Engineer and any such Subcontractor, Supplier or other individual or entity; nor
  2. shall create any obligation on the part of Owner or Engineer to pay or to see to the payment of any moneys due any such Subcontractor, Supplier, or other individual or entity except as may otherwise be required by Laws and Regulations.
- D. Contractor shall be solely responsible for scheduling and coordinating the Work of Subcontractors, Suppliers, and other individuals or entities performing or furnishing any of the Work under a direct or indirect contract with Contractor.
- E. Contractor shall require all Subcontractors, Suppliers, and such other individuals or entities performing or furnishing any of the Work to communicate with Engineer through Contractor.
- F. The divisions and sections of the Specifications and the identifications of any Drawings shall not control Contractor in dividing the Work among Subcontractors or Suppliers or delineating the Work to be performed by any specific trade.
- G. All Work performed for Contractor by a Subcontractor or Supplier will be pursuant to an appropriate agreement between Contractor and the Subcontractor or Supplier which specifically binds the Subcontractor or Supplier to the applicable terms and conditions of the Contract Documents for the benefit of Owner and Engineer. Whenever any such agreement is with a Subcontractor or Supplier who is listed as a loss payee on the property insurance provided in Paragraph 5.06, the agreement between the Contractor and the Subcontractor or Supplier will contain provisions whereby the Subcontractor or Supplier waives all rights against Owner,

Contractor, Engineer, and all other individuals or entities identified in the Supplementary Conditions to be listed as insureds or loss payees (and the officers, directors, members, partners, employees, agents, consultants, and subcontractors of each and any of them) for all losses and damages caused by, arising out of, relating to, or resulting from any of the perils or causes of loss covered by such policies and any other property insurance applicable to the Work. If the insurers on any such policies require separate waiver forms to be signed by any Subcontractor or Supplier, Contractor will obtain the same.

6.07 *Patent Fees and Royalties*

- A. Contractor shall pay all license fees and royalties and assume all costs incident to the use in the performance of the Work or the incorporation in the Work of any invention, design, process, product, or device which is the subject of patent rights or copyrights held by others. If a particular invention, design, process, product, or device is specified in the Contract Documents for use in the performance of the Work and if, to the actual knowledge of Owner or Engineer, its use is subject to patent rights or copyrights calling for the payment of any license fee or royalty to others, the existence of such rights shall be disclosed by Owner in the Contract Documents.
- B. To the fullest extent permitted by Laws and Regulations, Owner shall indemnify and hold harmless Contractor, and its officers, directors, members, partners, employees, agents, consultants, and subcontractors from and against all claims, costs, losses, and damages (including but not limited to all fees and charges of engineers, architects, attorneys, and other professionals, and all court or arbitration or other dispute resolution costs) arising out of or relating to any infringement of patent rights or copyrights incident to the use in the performance of the Work or resulting from the incorporation in the Work of any invention, design, process, product, or device specified in the Contract Documents, but not identified as being subject to payment of any license fee or royalty to others required by patent rights or copyrights.
- C. To the fullest extent permitted by Laws and Regulations, Contractor shall indemnify and hold harmless Owner and Engineer, and the officers, directors, members, partners, employees, agents, consultants and subcontractors of each and any of them from and against all claims, costs, losses, and damages (including but not limited to all fees and charges of engineers, architects, attorneys, and other professionals and all court or arbitration or other dispute resolution costs) arising out of or relating to any infringement of patent rights or copyrights incident to the use in the performance of the Work or resulting from the incorporation in the Work of any invention, design, process, product, or device not specified in the Contract Documents.

6.08 *Permits*

- A. Unless otherwise provided in the Supplementary Conditions, Contractor shall obtain and pay for all construction permits and licenses. Owner shall assist Contractor, when necessary, in obtaining such permits and licenses. Contractor shall pay all governmental charges and inspection fees necessary for the prosecution of the Work which are applicable at the time of opening of Bids, or, if there are no Bids, on the Effective Date of the Agreement. Owner shall pay all charges of utility owners for connections for providing permanent service to the Work.

6.09 *Laws and Regulations*

- A. Contractor shall give all notices required by and shall comply with all Laws and Regulations applicable to the performance of the Work. Except where otherwise expressly required by applicable Laws and Regulations, neither Owner nor Engineer shall be responsible for monitoring Contractor's compliance with any Laws or Regulations.
- B. If Contractor performs any Work knowing or having reason to know that it is contrary to Laws or Regulations, Contractor shall bear all claims, costs, losses, and damages (including but not limited to all fees and charges of engineers, architects, attorneys, and other professionals and all court or arbitration or other dispute resolution costs) arising out of or relating to such Work. However, it shall not be Contractor's responsibility to make certain that the Specifications and Drawings are in accordance with Laws and Regulations, but this shall not relieve Contractor of Contractor's obligations under Paragraph 3.03.
- C. Changes in Laws or Regulations not known at the time of opening of Bids (or, on the Effective Date of the Agreement if there were no Bids) having an effect on the cost or time of performance of the Work shall be the subject of an adjustment in Contract Price or Contract Times. If Owner and Contractor are unable to agree on entitlement to or on the amount or extent, if any, of any such adjustment, a Claim may be made therefor as provided in Paragraph 10.05.

6.10 *Taxes*

- A. Contractor shall pay all sales, consumer, use, and other similar taxes required to be paid by Contractor in accordance with the Laws and Regulations of the place of the Project which are applicable during the performance of the Work.

6.11 *Use of Site and Other Areas*

A. *Limitation on Use of Site and Other Areas:*

1. Contractor shall confine construction equipment, the storage of materials and equipment, and the operations of workers to the Site and other areas permitted by Laws and Regulations, and shall not unreasonably encumber the Site and other areas with construction equipment or other materials or equipment. Contractor shall assume full responsibility for any damage to any such land or area, or to the owner or occupant thereof, or of any adjacent land or areas resulting from the performance of the Work.
2. Should any claim be made by any such owner or occupant because of the performance of the Work, Contractor shall promptly settle with such other party by negotiation or otherwise resolve the claim by arbitration or other dispute resolution proceeding or at law.
3. To the fullest extent permitted by Laws and Regulations, Contractor shall indemnify and hold harmless Owner and Engineer, and the officers, directors, members, partners, employees, agents, consultants and subcontractors of each and any of them from and against all claims, costs, losses, and damages (including but not limited to all fees and charges of engineers, architects, attorneys, and other professionals and all court or arbitration or other dispute resolution costs) arising out of or relating to any claim or action, legal or equitable, brought

by any such owner or occupant against Owner, Engineer, or any other party indemnified hereunder to the extent caused by or based upon Contractor's performance of the Work.

- B. *Removal of Debris During Performance of the Work:* During the progress of the Work Contractor shall keep the Site and other areas free from accumulations of waste materials, rubbish, and other debris. Removal and disposal of such waste materials, rubbish, and other debris shall conform to applicable Laws and Regulations.
- C. *Cleaning:* Prior to Substantial Completion of the Work Contractor shall clean the Site and the Work and make it ready for utilization by Owner. At the completion of the Work Contractor shall remove from the Site all tools, appliances, construction equipment and machinery, and surplus materials and shall restore to original condition all property not designated for alteration by the Contract Documents.
- D. *Loading Structures:* Contractor shall not load nor permit any part of any structure to be loaded in any manner that will endanger the structure, nor shall Contractor subject any part of the Work or adjacent property to stresses or pressures that will endanger it.

#### 6.12 *Record Documents*

- A. Contractor shall maintain in a safe place at the Site one record copy of all Drawings, Specifications, Addenda, Change Orders, Work Change Directives, Field Orders, and written interpretations and clarifications in good order and annotated to show changes made during construction. These record documents together with all approved Samples and a counterpart of all approved Shop Drawings will be available to Engineer for reference. Upon completion of the Work, these record documents, Samples, and Shop Drawings will be delivered to Engineer for Owner.

#### 6.13 *Safety and Protection*

- A. Contractor shall be solely responsible for initiating, maintaining and supervising all safety precautions and programs in connection with the Work. Such responsibility does not relieve Subcontractors of their responsibility for the safety of persons or property in the performance of their work, nor for compliance with applicable safety Laws and Regulations. Contractor shall take all necessary precautions for the safety of, and shall provide the necessary protection to prevent damage, injury or loss to:
  - 1. all persons on the Site or who may be affected by the Work;
  - 2. all the Work and materials and equipment to be incorporated therein, whether in storage on or off the Site; and
  - 3. other property at the Site or adjacent thereto, including trees, shrubs, lawns, walks, pavements, roadways, structures, utilities, and Underground Facilities not designated for removal, relocation, or replacement in the course of construction.

- B. Contractor shall comply with all applicable Laws and Regulations relating to the safety of persons or property, or to the protection of persons or property from damage, injury, or loss; and shall erect and maintain all necessary safeguards for such safety and protection. Contractor shall notify owners of adjacent property and of Underground Facilities and other utility owners when prosecution of the Work may affect them, and shall cooperate with them in the protection, removal, relocation, and replacement of their property.
- C. Contractor shall comply with the applicable requirements of Owner's safety programs, if any. The Supplementary Conditions identify any Owner's safety programs that are applicable to the Work.
- D. Contractor shall inform Owner and Engineer of the specific requirements of Contractor's safety program with which Owner's and Engineer's employees and representatives must comply while at the Site.
- E. All damage, injury, or loss to any property referred to in Paragraph 6.13.A.2 or 6.13.A.3 caused, directly or indirectly, in whole or in part, by Contractor, any Subcontractor, Supplier, or any other individual or entity directly or indirectly employed by any of them to perform any of the Work, or anyone for whose acts any of them may be liable, shall be remedied by Contractor (except damage or loss attributable to the fault of Drawings or Specifications or to the acts or omissions of Owner or Engineer or anyone employed by any of them, or anyone for whose acts any of them may be liable, and not attributable, directly or indirectly, in whole or in part, to the fault or negligence of Contractor or any Subcontractor, Supplier, or other individual or entity directly or indirectly employed by any of them).
- F. Contractor's duties and responsibilities for safety and for protection of the Work shall continue until such time as all the Work is completed and Engineer has issued a notice to Owner and Contractor in accordance with Paragraph 14.07.B that the Work is acceptable (except as otherwise expressly provided in connection with Substantial Completion).

6.14 *Safety Representative*

- A. Contractor shall designate a qualified and experienced safety representative at the Site whose duties and responsibilities shall be the prevention of accidents and the maintaining and supervising of safety precautions and programs.

6.15 *Hazard Communication Programs*

- A. Contractor shall be responsible for coordinating any exchange of material safety data sheets or other hazard communication information required to be made available to or exchanged between or among employers at the Site in accordance with Laws or Regulations.

6.16 *Emergencies*

- A. In emergencies affecting the safety or protection of persons or the Work or property at the Site or adjacent thereto, Contractor is obligated to act to prevent threatened damage, injury, or loss. Contractor shall give Engineer prompt written notice if Contractor believes that any significant changes in the Work or variations from the Contract Documents have been caused thereby or are

required as a result thereof. If Engineer determines that a change in the Contract Documents is required because of the action taken by Contractor in response to such an emergency, a Work Change Directive or Change Order will be issued.

#### 6.17 *Shop Drawings and Samples*

A. Contractor shall submit Shop Drawings and Samples to Engineer for review and approval in accordance with the accepted Schedule of Submittals (as required by Paragraph 2.07). Each submittal will be identified as Engineer may require.

##### 1. *Shop Drawings:*

- a. Submit number of copies specified in the General Requirements.
- b. Data shown on the Shop Drawings will be complete with respect to quantities, dimensions, specified performance and design criteria, materials, and similar data to show Engineer the services, materials, and equipment Contractor proposes to provide and to enable Engineer to review the information for the limited purposes required by Paragraph 6.17.D.

##### 2. *Samples:*

- a. Submit number of Samples specified in the Specifications.
- b. Clearly identify each Sample as to material, Supplier, pertinent data such as catalog numbers, the use for which intended and other data as Engineer may require to enable Engineer to review the submittal for the limited purposes required by Paragraph 6.17.D.

B. Where a Shop Drawing or Sample is required by the Contract Documents or the Schedule of Submittals, any related Work performed prior to Engineer's review and approval of the pertinent submittal will be at the sole expense and responsibility of Contractor.

##### C. *Submittal Procedures:*

1. Before submitting each Shop Drawing or Sample, Contractor shall have:

- a. reviewed and coordinated each Shop Drawing or Sample with other Shop Drawings and Samples and with the requirements of the Work and the Contract Documents;
- b. determined and verified all field measurements, quantities, dimensions, specified performance and design criteria, installation requirements, materials, catalog numbers, and similar information with respect thereto;
- c. determined and verified the suitability of all materials offered with respect to the indicated application, fabrication, shipping, handling, storage, assembly, and installation pertaining to the performance of the Work; and

- d. determined and verified all information relative to Contractor's responsibilities for means, methods, techniques, sequences, and procedures of construction, and safety precautions and programs incident thereto.
2. Each submittal shall bear a stamp or specific written certification that Contractor has satisfied Contractor's obligations under the Contract Documents with respect to Contractor's review and approval of that submittal.
3. With each submittal, Contractor shall give Engineer specific written notice of any variations that the Shop Drawing or Sample may have from the requirements of the Contract Documents. This notice shall be both a written communication separate from the Shop Drawings or Sample submittal; and, in addition, by a specific notation made on each Shop Drawing or Sample submitted to Engineer for review and approval of each such variation.

*D. Engineer's Review:*

1. Engineer will provide timely review of Shop Drawings and Samples in accordance with the Schedule of Submittals acceptable to Engineer. Engineer's review and approval will be only to determine if the items covered by the submittals will, after installation or incorporation in the Work, conform to the information given in the Contract Documents and be compatible with the design concept of the completed Project as a functioning whole as indicated by the Contract Documents.
2. Engineer's review and approval will not extend to means, methods, techniques, sequences, or procedures of construction (except where a particular means, method, technique, sequence, or procedure of construction is specifically and expressly called for by the Contract Documents) or to safety precautions or programs incident thereto. The review and approval of a separate item as such will not indicate approval of the assembly in which the item functions.
3. Engineer's review and approval shall not relieve Contractor from responsibility for any variation from the requirements of the Contract Documents unless Contractor has complied with the requirements of Paragraph 6.17.C.3 and Engineer has given written approval of each such variation by specific written notation thereof incorporated in or accompanying the Shop Drawing or Sample. Engineer's review and approval shall not relieve Contractor from responsibility for complying with the requirements of Paragraph 6.17.C.1.

*E. Resubmittal Procedures:*

1. Contractor shall make corrections required by Engineer and shall return the required number of corrected copies of Shop Drawings and submit, as required, new Samples for review and approval. Contractor shall direct specific attention in writing to revisions other than the corrections called for by Engineer on previous submittals.

**6.18** *Continuing the Work*

- A. Contractor shall carry on the Work and adhere to the Progress Schedule during all disputes or disagreements with Owner. No Work shall be delayed or postponed pending resolution of any



disputes or disagreements, except as permitted by Paragraph 15.04 or as Owner and Contractor may otherwise agree in writing.

6.19 *Contractor's General Warranty and Guarantee*

- A. Contractor warrants and guarantees to Owner that all Work will be in accordance with the Contract Documents and will not be defective. Engineer and its officers, directors, members, partners, employees, agents, consultants, and subcontractors shall be entitled to rely on representation of Contractor's warranty and guarantee.
- B. Contractor's warranty and guarantee hereunder excludes defects or damage caused by:
  - 1. abuse, modification, or improper maintenance or operation by persons other than Contractor, Subcontractors, Suppliers, or any other individual or entity for whom Contractor is responsible; or
  - 2. normal wear and tear under normal usage.
- C. Contractor's obligation to perform and complete the Work in accordance with the Contract Documents shall be absolute. None of the following will constitute an acceptance of Work that is not in accordance with the Contract Documents or a release of Contractor's obligation to perform the Work in accordance with the Contract Documents:
  - 1. observations by Engineer;
  - 2. recommendation by Engineer or payment by Owner of any progress or final payment;
  - 3. the issuance of a certificate of Substantial Completion by Engineer or any payment related thereto by Owner;
  - 4. use or occupancy of the Work or any part thereof by Owner;
  - 5. any review and approval of a Shop Drawing or Sample submittal or the issuance of a notice of acceptability by Engineer;
  - 6. any inspection, test, or approval by others; or
  - 7. any correction of defective Work by Owner.

6.20 *Indemnification*

- A. To the fullest extent permitted by Laws and Regulations, Contractor shall indemnify and hold harmless Owner and Engineer, and the officers, directors, members, partners, employees, agents, consultants and subcontractors of each and any of them from and against all claims, costs, losses, and damages (including but not limited to all fees and charges of engineers, architects, attorneys, and other professionals and all court or arbitration or other dispute resolution costs) arising out of or relating to the performance of the Work, provided that any such claim, cost, loss, or damage is attributable to bodily injury, sickness, disease, or death, or to injury to or destruction of tangible property (other than the Work itself), including the loss of use resulting therefrom but only to the

extent caused by any negligent act or omission of Contractor, any Subcontractor, any Supplier, or any individual or entity directly or indirectly employed by any of them to perform any of the Work or anyone for whose acts any of them may be liable .

- B. In any and all claims against Owner or Engineer or any of their officers, directors, members, partners, employees, agents, consultants, or subcontractors by any employee (or the survivor or personal representative of such employee) of Contractor, any Subcontractor, any Supplier, or any individual or entity directly or indirectly employed by any of them to perform any of the Work, or anyone for whose acts any of them may be liable, the indemnification obligation under Paragraph 6.20.A shall not be limited in any way by any limitation on the amount or type of damages, compensation, or benefits payable by or for Contractor or any such Subcontractor, Supplier, or other individual or entity under workers' compensation acts, disability benefit acts, or other employee benefit acts.
- C. The indemnification obligations of Contractor under Paragraph 6.20.A shall not extend to the liability of Engineer and Engineer's officers, directors, members, partners, employees, agents, consultants and subcontractors arising out of:
  - 1. the preparation or approval of, or the failure to prepare or approve maps, Drawings, opinions, reports, surveys, Change Orders, designs, or Specifications; or
  - 2. giving directions or instructions, or failing to give them, if that is the primary cause of the injury or damage.

#### 6.21 *Delegation of Professional Design Services*

- A. Contractor will not be required to provide professional design services unless such services are specifically required by the Contract Documents for a portion of the Work or unless such services are required to carry out Contractor's responsibilities for construction means, methods, techniques, sequences and procedures. Contractor shall not be required to provide professional services in violation of applicable law.
- B. If professional design services or certifications by a design professional related to systems, materials or equipment are specifically required of Contractor by the Contract Documents, Owner and Engineer will specify all performance and design criteria that such services must satisfy. Contractor shall cause such services or certifications to be provided by a properly licensed professional, whose signature and seal shall appear on all drawings, calculations, specifications, certifications, Shop Drawings and other submittals prepared by such professional. Shop Drawings and other submittals related to the Work designed or certified by such professional, if prepared by others, shall bear such professional's written approval when submitted to Engineer.
- C. Owner and Engineer shall be entitled to rely upon the adequacy, accuracy and completeness of the services, certifications or approvals performed by such design professionals, provided Owner and Engineer have specified to Contractor all performance and design criteria that such services must satisfy.

- D. Pursuant to this Paragraph 6.21, Engineer's review and approval of design calculations and design drawings will be only for the limited purpose of checking for conformance with performance and design criteria given and the design concept expressed in the Contract Documents. Engineer's review and approval of Shop Drawings and other submittals (except design calculations and design drawings) will be only for the purpose stated in Paragraph 6.17.D.1.
- E. Contractor shall not be responsible for the adequacy of the performance or design criteria required by the Contract Documents.

## ARTICLE 7 – OTHER WORK AT THE SITE

### 7.01 *Related Work at Site*

- A. Owner may perform other work related to the Project at the Site with Owner's employees, or through other direct contracts therefor, or have other work performed by utility owners. If such other work is not noted in the Contract Documents, then:
  - 1. written notice thereof will be given to Contractor prior to starting any such other work; and
  - 2. if Owner and Contractor are unable to agree on entitlement to or on the amount or extent, if any, of any adjustment in the Contract Price or Contract Times that should be allowed as a result of such other work, a Claim may be made therefor as provided in Paragraph 10.05.
- B. Contractor shall afford each other contractor who is a party to such a direct contract, each utility owner, and Owner, if Owner is performing other work with Owner's employees, proper and safe access to the Site, provide a reasonable opportunity for the introduction and storage of materials and equipment and the execution of such other work, and properly coordinate the Work with theirs. Contractor shall do all cutting, fitting, and patching of the Work that may be required to properly connect or otherwise make its several parts come together and properly integrate with such other work. Contractor shall not endanger any work of others by cutting, excavating, or otherwise altering such work; provided, however, that Contractor may cut or alter others' work with the written consent of Engineer and the others whose work will be affected. The duties and responsibilities of Contractor under this Paragraph are for the benefit of such utility owners and other contractors to the extent that there are comparable provisions for the benefit of Contractor in said direct contracts between Owner and such utility owners and other contractors.
- C. If the proper execution or results of any part of Contractor's Work depends upon work performed by others under this Article 7, Contractor shall inspect such other work and promptly report to Engineer in writing any delays, defects, or deficiencies in such other work that render it unavailable or unsuitable for the proper execution and results of Contractor's Work. Contractor's failure to so report will constitute an acceptance of such other work as fit and proper for integration with Contractor's Work except for latent defects and deficiencies in such other work.

### 7.02 *Coordination*

- A. If Owner intends to contract with others for the performance of other work on the Project at the Site, the following will be set forth in Supplementary Conditions:

1. the individual or entity who will have authority and responsibility for coordination of the activities among the various contractors will be identified;
  2. the specific matters to be covered by such authority and responsibility will be itemized; and
  3. the extent of such authority and responsibilities will be provided.
- B. Unless otherwise provided in the Supplementary Conditions, Owner shall have sole authority and responsibility for such coordination.

7.03 *Legal Relationships*

- A. Paragraphs 7.01.A and 7.02 are not applicable for utilities not under the control of Owner.
- B. Each other direct contract of Owner under Paragraph 7.01.A shall provide that the other contractor is liable to Owner and Contractor for the reasonable direct delay and disruption costs incurred by Contractor as a result of the other contractor's wrongful actions or inactions.
- C. Contractor shall be liable to Owner and any other contractor under direct contract to Owner for the reasonable direct delay and disruption costs incurred by such other contractor as a result of Contractor's wrongful action or inactions.

**ARTICLE 8 – OWNER'S RESPONSIBILITIES**

8.01 *Communications to Contractor*

- A. Except as otherwise provided in these General Conditions, Owner shall issue all communications to Contractor through Engineer.

8.02 *Replacement of Engineer*

- A. In case of termination of the employment of Engineer, Owner shall appoint an engineer to whom Contractor makes no reasonable objection, whose status under the Contract Documents shall be that of the former Engineer.

8.03 *Furnish Data*

- A. Owner shall promptly furnish the data required of Owner under the Contract Documents.

8.04 *Pay When Due*

- A. Owner shall make payments to Contractor when they are due as provided in Paragraphs 14.02.C and 14.07.C.

8.05 *Lands and Easements; Reports and Tests*

- A. Owner's duties with respect to providing lands and easements and providing engineering surveys to establish reference points are set forth in Paragraphs 4.01 and 4.05. Paragraph 4.02 refers to Owner's identifying and making available to Contractor copies of reports of explorations and

tests of subsurface conditions and drawings of physical conditions relating to existing surface or subsurface structures at the Site.

8.06 *Insurance*

A. Owner's responsibilities, if any, with respect to purchasing and maintaining liability and property insurance are set forth in Article 5.

8.07 *Change Orders*

A. Owner is obligated to execute Change Orders as indicated in Paragraph 10.03.

8.08 *Inspections, Tests, and Approvals*

A. Owner's responsibility with respect to certain inspections, tests, and approvals is set forth in Paragraph 13.03.B.

8.09 *Limitations on Owner's Responsibilities*

A. The Owner shall not supervise, direct, or have control or authority over, nor be responsible for, Contractor's means, methods, techniques, sequences, or procedures of construction, or the safety precautions and programs incident thereto, or for any failure of Contractor to comply with Laws and Regulations applicable to the performance of the Work. Owner will not be responsible for Contractor's failure to perform the Work in accordance with the Contract Documents.

8.10 *Undisclosed Hazardous Environmental Condition*

A. Owner's responsibility in respect to an undisclosed Hazardous Environmental Condition is set forth in Paragraph 4.06.

8.11 *Evidence of Financial Arrangements*

A. Upon request of Contractor, Owner shall furnish Contractor reasonable evidence that financial arrangements have been made to satisfy Owner's obligations under the Contract Documents.

8.12 *Compliance with Safety Program*

A. While at the Site, Owner's employees and representatives shall comply with the specific applicable requirements of Contractor's safety programs of which Owner has been informed pursuant to Paragraph 6.13.D.

## **ARTICLE 9 – ENGINEER'S STATUS DURING CONSTRUCTION**

9.01 *Owner's Representative*

A. Engineer will be Owner's representative during the construction period. The duties and responsibilities and the limitations of authority of Engineer as Owner's representative during construction are set forth in the Contract Documents.

## 9.02 *Visits to Site*

- A. Engineer will make visits to the Site at intervals appropriate to the various stages of construction as Engineer deems necessary in order to observe as an experienced and qualified design professional the progress that has been made and the quality of the various aspects of Contractor's executed Work. Based on information obtained during such visits and observations, Engineer, for the benefit of Owner, will determine, in general, if the Work is proceeding in accordance with the Contract Documents. Engineer will not be required to make exhaustive or continuous inspections on the Site to check the quality or quantity of the Work. Engineer's efforts will be directed toward providing for Owner a greater degree of confidence that the completed Work will conform generally to the Contract Documents. On the basis of such visits and observations, Engineer will keep Owner informed of the progress of the Work and will endeavor to guard Owner against defective Work.
- B. Engineer's visits and observations are subject to all the limitations on Engineer's authority and responsibility set forth in Paragraph 9.09. Particularly, but without limitation, during or as a result of Engineer's visits or observations of Contractor's Work, Engineer will not supervise, direct, control, or have authority over or be responsible for Contractor's means, methods, techniques, sequences, or procedures of construction, or the safety precautions and programs incident thereto, or for any failure of Contractor to comply with Laws and Regulations applicable to the performance of the Work.

## 9.03 *Project Representative*

- A. If Owner and Engineer agree, Engineer will furnish a Resident Project Representative to assist Engineer in providing more extensive observation of the Work. The authority and responsibilities of any such Resident Project Representative and assistants will be as provided in the Supplementary Conditions, and limitations on the responsibilities thereof will be as provided in Paragraph 9.09. If Owner designates another representative or agent to represent Owner at the Site who is not Engineer's consultant, agent or employee, the responsibilities and authority and limitations thereon of such other individual or entity will be as provided in the Supplementary Conditions.

## 9.04 *Authorized Variations in Work*

- A. Engineer may authorize minor variations in the Work from the requirements of the Contract Documents which do not involve an adjustment in the Contract Price or the Contract Times and are compatible with the design concept of the completed Project as a functioning whole as indicated by the Contract Documents. These may be accomplished by a Field Order and will be binding on Owner and also on Contractor, who shall perform the Work involved promptly. If Owner or Contractor believes that a Field Order justifies an adjustment in the Contract Price or Contract Times, or both, and the parties are unable to agree on entitlement to or on the amount or extent, if any, of any such adjustment, a Claim may be made therefor as provided in Paragraph 10.05.

9.05 *Rejecting Defective Work*

- A. Engineer will have authority to reject Work which Engineer believes to be defective, or that Engineer believes will not produce a completed Project that conforms to the Contract Documents or that will prejudice the integrity of the design concept of the completed Project as a functioning whole as indicated by the Contract Documents. Engineer will also have authority to require special inspection or testing of the Work as provided in Paragraph 13.04, whether or not the Work is fabricated, installed, or completed.

9.06 *Shop Drawings, Change Orders and Payments*

- A. In connection with Engineer's authority, and limitations thereof, as to Shop Drawings and Samples, see Paragraph 6.17.
- B. In connection with Engineer's authority, and limitations thereof, as to design calculations and design drawings submitted in response to a delegation of professional design services, if any, see Paragraph 6.21.
- C. In connection with Engineer's authority as to Change Orders, see Articles 10, 11, and 12.
- D. In connection with Engineer's authority as to Applications for Payment, see Article 14.

9.07 *Determinations for Unit Price Work*

- A. Engineer will determine the actual quantities and classifications of Unit Price Work performed by Contractor. Engineer will review with Contractor the Engineer's preliminary determinations on such matters before rendering a written decision thereon (by recommendation of an Application for Payment or otherwise). Engineer's written decision thereon will be final and binding (except as modified by Engineer to reflect changed factual conditions or more accurate data) upon Owner and Contractor, subject to the provisions of Paragraph 10.05.

9.08 *Decisions on Requirements of Contract Documents and Acceptability of Work*

- A. Engineer will be the initial interpreter of the requirements of the Contract Documents and judge of the acceptability of the Work thereunder. All matters in question and other matters between Owner and Contractor arising prior to the date final payment is due relating to the acceptability of the Work, and the interpretation of the requirements of the Contract Documents pertaining to the performance of the Work, will be referred initially to Engineer in writing within 30 days of the event giving rise to the question.
- B. Engineer will, with reasonable promptness, render a written decision on the issue referred. If Owner or Contractor believes that any such decision entitles them to an adjustment in the Contract Price or Contract Times or both, a Claim may be made under Paragraph 10.05. The date of Engineer's decision shall be the date of the event giving rise to the issues referenced for the purposes of Paragraph 10.05.B.
- C. Engineer's written decision on the issue referred will be final and binding on Owner and Contractor, subject to the provisions of Paragraph 10.05.

- D. When functioning as interpreter and judge under this Paragraph 9.08, Engineer will not show partiality to Owner or Contractor and will not be liable in connection with any interpretation or decision rendered in good faith in such capacity.

9.09 *Limitations on Engineer's Authority and Responsibilities*

- A. Neither Engineer's authority or responsibility under this Article 9 or under any other provision of the Contract Documents nor any decision made by Engineer in good faith either to exercise or not exercise such authority or responsibility or the undertaking, exercise, or performance of any authority or responsibility by Engineer shall create, impose, or give rise to any duty in contract, tort, or otherwise owed by Engineer to Contractor, any Subcontractor, any Supplier, any other individual or entity, or to any surety for or employee or agent of any of them.
- B. Engineer will not supervise, direct, control, or have authority over or be responsible for Contractor's means, methods, techniques, sequences, or procedures of construction, or the safety precautions and programs incident thereto, or for any failure of Contractor to comply with Laws and Regulations applicable to the performance of the Work. Engineer will not be responsible for Contractor's failure to perform the Work in accordance with the Contract Documents.
- C. Engineer will not be responsible for the acts or omissions of Contractor or of any Subcontractor, any Supplier, or of any other individual or entity performing any of the Work.
- D. Engineer's review of the final Application for Payment and accompanying documentation and all maintenance and operating instructions, schedules, guarantees, bonds, certificates of inspection, tests and approvals, and other documentation required to be delivered by Paragraph 14.07.A will only be to determine generally that their content complies with the requirements of, and in the case of certificates of inspections, tests, and approvals that the results certified indicate compliance with, the Contract Documents.
- E. The limitations upon authority and responsibility set forth in this Paragraph 9.09 shall also apply to the Resident Project Representative, if any, and assistants, if any.

9.10 *Compliance with Safety Program*

- A. While at the Site, Engineer's employees and representatives shall comply with the specific applicable requirements of Contractor's safety programs of which Engineer has been informed pursuant to Paragraph 6.13.D.

**ARTICLE 10 – CHANGES IN THE WORK; CLAIMS**

10.01 *Authorized Changes in the Work*

- A. Without invalidating the Contract and without notice to any surety, Owner may, at any time or from time to time, order additions, deletions, or revisions in the Work by a Change Order, or a Work Change Directive. Upon receipt of any such document, Contractor shall promptly proceed with the Work involved which will be performed under the applicable conditions of the Contract Documents (except as otherwise specifically provided).



- B. If Owner and Contractor are unable to agree on entitlement to, or on the amount or extent, if any, of an adjustment in the Contract Price or Contract Times, or both, that should be allowed as a result of a Work Change Directive, a Claim may be made therefor as provided in Paragraph 10.05.

#### 10.02 *Unauthorized Changes in the Work*

- A. Contractor shall not be entitled to an increase in the Contract Price or an extension of the Contract Times with respect to any work performed that is not required by the Contract Documents as amended, modified, or supplemented as provided in Paragraph 3.04, except in the case of an emergency as provided in Paragraph 6.16 or in the case of uncovering Work as provided in Paragraph 13.04.D.

#### 10.03 *Execution of Change Orders*

- A. Owner and Contractor shall execute appropriate Change Orders recommended by Engineer covering:
1. changes in the Work which are: (i) ordered by Owner pursuant to Paragraph 10.01.A, (ii) required because of acceptance of defective Work under Paragraph 13.08.A or Owner's correction of defective Work under Paragraph 13.09, or (iii) agreed to by the parties;
  2. changes in the Contract Price or Contract Times which are agreed to by the parties, including any undisputed sum or amount of time for Work actually performed in accordance with a Work Change Directive; and
  3. changes in the Contract Price or Contract Times which embody the substance of any written decision rendered by Engineer pursuant to Paragraph 10.05; provided that, in lieu of executing any such Change Order, an appeal may be taken from any such decision in accordance with the provisions of the Contract Documents and applicable Laws and Regulations, but during any such appeal, Contractor shall carry on the Work and adhere to the Progress Schedule as provided in Paragraph 6.18.A.

#### 10.04 *Notification to Surety*

- A. If the provisions of any bond require notice to be given to a surety of any change affecting the general scope of the Work or the provisions of the Contract Documents (including, but not limited to, Contract Price or Contract Times), the giving of any such notice will be Contractor's responsibility. The amount of each applicable bond will be adjusted to reflect the effect of any such change.

#### 10.05 *Claims*

- A. *Engineer's Decision Required:* All Claims, except those waived pursuant to Paragraph 14.09, shall be referred to the Engineer for decision. A decision by Engineer shall be required as a condition precedent to any exercise by Owner or Contractor of any rights or remedies either may otherwise have under the Contract Documents or by Laws and Regulations in respect of such Claims.

- B. *Notice:* Written notice stating the general nature of each Claim shall be delivered by the claimant to Engineer and the other party to the Contract promptly (but in no event later than 30 days) after the start of the event giving rise thereto. The responsibility to substantiate a Claim shall rest with the party making the Claim. Notice of the amount or extent of the Claim, with supporting data shall be delivered to the Engineer and the other party to the Contract within 60 days after the start of such event (unless Engineer allows additional time for claimant to submit additional or more accurate data in support of such Claim). A Claim for an adjustment in Contract Price shall be prepared in accordance with the provisions of Paragraph 12.01.B. A Claim for an adjustment in Contract Times shall be prepared in accordance with the provisions of Paragraph 12.02.B. Each Claim shall be accompanied by claimant's written statement that the adjustment claimed is the entire adjustment to which the claimant believes it is entitled as a result of said event. The opposing party shall submit any response to Engineer and the claimant within 30 days after receipt of the claimant's last submittal (unless Engineer allows additional time).
- C. *Engineer's Action:* Engineer will review each Claim and, within 30 days after receipt of the last submittal of the claimant or the last submittal of the opposing party, if any, take one of the following actions in writing:
1. deny the Claim in whole or in part;
  2. approve the Claim; or
  3. notify the parties that the Engineer is unable to resolve the Claim if, in the Engineer's sole discretion, it would be inappropriate for the Engineer to do so. For purposes of further resolution of the Claim, such notice shall be deemed a denial.
- D. In the event that Engineer does not take action on a Claim within said 30 days, the Claim shall be deemed denied.
- E. Engineer's written action under Paragraph 10.05.C or denial pursuant to Paragraphs 10.05.C.3 or 10.05.D will be final and binding upon Owner and Contractor, unless Owner or Contractor invoke the dispute resolution procedure set forth in Article 16 within 30 days of such action or denial.
- F. No Claim for an adjustment in Contract Price or Contract Times will be valid if not submitted in accordance with this Paragraph 10.05.

## **ARTICLE 11 – COST OF THE WORK; ALLOWANCES; UNIT PRICE WORK**

### **11.01 *Cost of the Work***

- A. *Costs Included:* The term Cost of the Work means the sum of all costs, except those excluded in Paragraph 11.01.B, necessarily incurred and paid by Contractor in the proper performance of the Work. When the value of any Work covered by a Change Order or when a Claim for an adjustment in Contract Price is determined on the basis of Cost of the Work, the costs to be reimbursed to Contractor will be only those additional or incremental costs required because of the change in the Work or because of the event giving rise to the Claim. Except as otherwise may be agreed to in writing by Owner, such costs shall be in amounts no higher than those prevailing

in the locality of the Project, shall not include any of the costs itemized in Paragraph 11.01.B, and shall include only the following items:

1. Payroll costs for employees in the direct employ of Contractor in the performance of the Work under schedules of job classifications agreed upon by Owner and Contractor. Such employees shall include, without limitation, superintendents, foremen, and other personnel employed full time on the Work. Payroll costs for employees not employed full time on the Work shall be apportioned on the basis of their time spent on the Work. Payroll costs shall include, but not be limited to, salaries and wages plus the cost of fringe benefits, which shall include social security contributions, unemployment, excise, and payroll taxes, workers' compensation, health and retirement benefits, bonuses, sick leave, vacation and holiday pay applicable thereto. The expenses of performing Work outside of regular working hours, on Saturday, Sunday, or legal holidays, shall be included in the above to the extent authorized by Owner.
2. Cost of all materials and equipment furnished and incorporated in the Work, including costs of transportation and storage thereof, and Suppliers' field services required in connection therewith. All cash discounts shall accrue to Contractor unless Owner deposits funds with Contractor with which to make payments, in which case the cash discounts shall accrue to Owner. All trade discounts, rebates and refunds and returns from sale of surplus materials and equipment shall accrue to Owner, and Contractor shall make provisions so that they may be obtained.
3. Payments made by Contractor to Subcontractors for Work performed by Subcontractors. If required by Owner, Contractor shall obtain competitive bids from subcontractors acceptable to Owner and Contractor and shall deliver such bids to Owner, who will then determine, with the advice of Engineer, which bids, if any, will be acceptable. If any subcontract provides that the Subcontractor is to be paid on the basis of Cost of the Work plus a fee, the Subcontractor's Cost of the Work and fee shall be determined in the same manner as Contractor's Cost of the Work and fee as provided in this Paragraph 11.01.
4. Costs of special consultants (including but not limited to engineers, architects, testing laboratories, surveyors, attorneys, and accountants) employed for services specifically related to the Work.
5. Supplemental costs including the following:
  - a. The proportion of necessary transportation, travel, and subsistence expenses of Contractor's employees incurred in discharge of duties connected with the Work.
  - b. Cost, including transportation and maintenance, of all materials, supplies, equipment, machinery, appliances, office, and temporary facilities at the Site, and hand tools not owned by the workers, which are consumed in the performance of the Work, and cost, less market value, of such items used but not consumed which remain the property of Contractor.

- c. Rentals of all construction equipment and machinery, and the parts thereof whether rented from Contractor or others in accordance with rental agreements approved by Owner with the advice of Engineer, and the costs of transportation, loading, unloading, assembly, dismantling, and removal thereof. All such costs shall be in accordance with the terms of said rental agreements. The rental of any such equipment, machinery, or parts shall cease when the use thereof is no longer necessary for the Work.
- d. Sales, consumer, use, and other similar taxes related to the Work, and for which Contractor is liable, as imposed by Laws and Regulations.
- e. Deposits lost for causes other than negligence of Contractor, any Subcontractor, or anyone directly or indirectly employed by any of them or for whose acts any of them may be liable, and royalty payments and fees for permits and licenses.
- f. Losses and damages (and related expenses) caused by damage to the Work, not compensated by insurance or otherwise, sustained by Contractor in connection with the performance of the Work (except losses and damages within the deductible amounts of property insurance established in accordance with Paragraph 5.06.D), provided such losses and damages have resulted from causes other than the negligence of Contractor, any Subcontractor, or anyone directly or indirectly employed by any of them or for whose acts any of them may be liable. Such losses shall include settlements made with the written consent and approval of Owner. No such losses, damages, and expenses shall be included in the Cost of the Work for the purpose of determining Contractor's fee.
- g. The cost of utilities, fuel, and sanitary facilities at the Site.
- h. Minor expenses such as telegrams, long distance telephone calls, telephone service at the Site, express and courier services, and similar petty cash items in connection with the Work.
- i. The costs of premiums for all bonds and insurance Contractor is required by the Contract Documents to purchase and maintain.

B. *Costs Excluded:* The term Cost of the Work shall not include any of the following items:

- 1. Payroll costs and other compensation of Contractor's officers, executives, principals (of partnerships and sole proprietorships), general managers, safety managers, engineers, architects, estimators, attorneys, auditors, accountants, purchasing and contracting agents, expeditors, timekeepers, clerks, and other personnel employed by Contractor, whether at the Site or in Contractor's principal or branch office for general administration of the Work and not specifically included in the agreed upon schedule of job classifications referred to in Paragraph 11.01.A.1 or specifically covered by Paragraph 11.01.A.4, all of which are to be considered administrative costs covered by the Contractor's fee.
- 2. Expenses of Contractor's principal and branch offices other than Contractor's office at the Site.

3. Any part of Contractor's capital expenses, including interest on Contractor's capital employed for the Work and charges against Contractor for delinquent payments.
  4. Costs due to the negligence of Contractor, any Subcontractor, or anyone directly or indirectly employed by any of them or for whose acts any of them may be liable, including but not limited to, the correction of defective Work, disposal of materials or equipment wrongly supplied, and making good any damage to property.
  5. Other overhead or general expense costs of any kind and the costs of any item not specifically and expressly included in Paragraphs 11.01.A.
- C. *Contractor's Fee:* When all the Work is performed on the basis of cost-plus, Contractor's fee shall be determined as set forth in the Agreement. When the value of any Work covered by a Change Order or when a Claim for an adjustment in Contract Price is determined on the basis of Cost of the Work, Contractor's fee shall be determined as set forth in Paragraph 12.01.C.
- D. *Documentation:* Whenever the Cost of the Work for any purpose is to be determined pursuant to Paragraphs 11.01.A and 11.01.B, Contractor will establish and maintain records thereof in accordance with generally accepted accounting practices and submit in a form acceptable to Engineer an itemized cost breakdown together with supporting data.

#### 11.02 Allowances

- A. It is understood that Contractor has included in the Contract Price all allowances so named in the Contract Documents and shall cause the Work so covered to be performed for such sums and by such persons or entities as may be acceptable to Owner and Engineer.
- B. *Cash Allowances:*
1. Contractor agrees that:
    - a. the cash allowances include the cost to Contractor (less any applicable trade discounts) of materials and equipment required by the allowances to be delivered at the Site, and all applicable taxes; and
    - b. Contractor's costs for unloading and handling on the Site, labor, installation, overhead, profit, and other expenses contemplated for the cash allowances have been included in the Contract Price and not in the allowances, and no demand for additional payment on account of any of the foregoing will be valid.
- C. *Contingency Allowance:*
1. Contractor agrees that a contingency allowance, if any, is for the sole use of Owner to cover unanticipated costs.
- D. Prior to final payment, an appropriate Change Order will be issued as recommended by Engineer to reflect actual amounts due Contractor on account of Work covered by allowances, and the Contract Price shall be correspondingly adjusted.

### 11.03 *Unit Price Work*

- A. Where the Contract Documents provide that all or part of the Work is to be Unit Price Work, initially the Contract Price will be deemed to include for all Unit Price Work an amount equal to the sum of the unit price for each separately identified item of Unit Price Work times the estimated quantity of each item as indicated in the Agreement.
- B. The estimated quantities of items of Unit Price Work are not guaranteed and are solely for the purpose of comparison of Bids and determining an initial Contract Price. Determinations of the actual quantities and classifications of Unit Price Work performed by Contractor will be made by Engineer subject to the provisions of Paragraph 9.07.
- C. Each unit price will be deemed to include an amount considered by Contractor to be adequate to cover Contractor's overhead and profit for each separately identified item.
- D. Owner or Contractor may make a Claim for an adjustment in the Contract Price in accordance with Paragraph 10.05 if:
  1. the quantity of any item of Unit Price Work performed by Contractor differs materially and significantly from the estimated quantity of such item indicated in the Agreement; and
  2. there is no corresponding adjustment with respect to any other item of Work; and
  3. Contractor believes that Contractor is entitled to an increase in Contract Price as a result of having incurred additional expense or Owner believes that Owner is entitled to a decrease in Contract Price and the parties are unable to agree as to the amount of any such increase or decrease.

## **ARTICLE 12 – CHANGE OF CONTRACT PRICE; CHANGE OF CONTRACT TIMES**

### 12.01 *Change of Contract Price*

- A. The Contract Price may only be changed by a Change Order. Any Claim for an adjustment in the Contract Price shall be based on written notice submitted by the party making the Claim to the Engineer and the other party to the Contract in accordance with the provisions of Paragraph 10.05.
- B. The value of any Work covered by a Change Order or of any Claim for an adjustment in the Contract Price will be determined as follows:
  1. where the Work involved is covered by unit prices contained in the Contract Documents, by application of such unit prices to the quantities of the items involved (subject to the provisions of Paragraph 11.03); or
  2. where the Work involved is not covered by unit prices contained in the Contract Documents, by a mutually agreed lump sum (which may include an allowance for overhead and profit not necessarily in accordance with Paragraph 12.01.C.2); or

3. where the Work involved is not covered by unit prices contained in the Contract Documents and agreement to a lump sum is not reached under Paragraph 12.01.B.2, on the basis of the Cost of the Work (determined as provided in Paragraph 11.01) plus a Contractor's fee for overhead and profit (determined as provided in Paragraph 12.01.C).

C. *Contractor's Fee:* The Contractor's fee for overhead and profit shall be determined as follows:

1. a mutually acceptable fixed fee; or
2. if a fixed fee is not agreed upon, then a fee based on the following percentages of the various portions of the Cost of the Work:
  - a. for costs incurred under Paragraphs 11.01.A.1 and 11.01.A.2, the Contractor's fee shall be 15 percent;
  - b. for costs incurred under Paragraph 11.01.A.3, the Contractor's fee shall be five percent;
  - c. where one or more tiers of subcontracts are on the basis of Cost of the Work plus a fee and no fixed fee is agreed upon, the intent of Paragraphs 12.01.C.2.a and 12.01.C.2.b is that the Subcontractor who actually performs the Work, at whatever tier, will be paid a fee of 15 percent of the costs incurred by such Subcontractor under Paragraphs 11.01.A.1 and 11.01.A.2 and that any higher tier Subcontractor and Contractor will each be paid a fee of five percent of the amount paid to the next lower tier Subcontractor;
  - d. no fee shall be payable on the basis of costs itemized under Paragraphs 11.01.A.4, 11.01.A.5, and 11.01.B;
  - e. the amount of credit to be allowed by Contractor to Owner for any change which results in a net decrease in cost will be the amount of the actual net decrease in cost plus a deduction in Contractor's fee by an amount equal to five percent of such net decrease; and
  - f. when both additions and credits are involved in any one change, the adjustment in Contractor's fee shall be computed on the basis of the net change in accordance with Paragraphs 12.01.C.2.a through 12.01.C.2.e, inclusive.

## 12.02 *Change of Contract Times*

- A. The Contract Times may only be changed by a Change Order. Any Claim for an adjustment in the Contract Times shall be based on written notice submitted by the party making the Claim to the Engineer and the other party to the Contract in accordance with the provisions of Paragraph 10.05.
- B. Any adjustment of the Contract Times covered by a Change Order or any Claim for an adjustment in the Contract Times will be determined in accordance with the provisions of this Article 12.

### 12.03 *Delays*

- A. Where Contractor is prevented from completing any part of the Work within the Contract Times due to delay beyond the control of Contractor, the Contract Times will be extended in an amount equal to the time lost due to such delay if a Claim is made therefor as provided in Paragraph 12.02.A. Delays beyond the control of Contractor shall include, but not be limited to, acts or neglect by Owner, acts or neglect of utility owners or other contractors performing other work as contemplated by Article 7, fires, floods, epidemics, abnormal weather conditions, or acts of God.
- B. If Owner, Engineer, or other contractors or utility owners performing other work for Owner as contemplated by Article 7, or anyone for whom Owner is responsible, delays, disrupts, or interferes with the performance or progress of the Work, then Contractor shall be entitled to an equitable adjustment in the Contract Price or the Contract Times, or both. Contractor's entitlement to an adjustment of the Contract Times is conditioned on such adjustment being essential to Contractor's ability to complete the Work within the Contract Times.
- C. If Contractor is delayed in the performance or progress of the Work by fire, flood, epidemic, abnormal weather conditions, acts of God, acts or failures to act of utility owners not under the control of Owner, or other causes not the fault of and beyond control of Owner and Contractor, then Contractor shall be entitled to an equitable adjustment in Contract Times, if such adjustment is essential to Contractor's ability to complete the Work within the Contract Times. Such an adjustment shall be Contractor's sole and exclusive remedy for the delays described in this Paragraph 12.03.C.
- D. Owner, Engineer, and their officers, directors, members, partners, employees, agents, consultants, or subcontractors shall not be liable to Contractor for any claims, costs, losses, or damages (including but not limited to all fees and charges of engineers, architects, attorneys, and other professionals and all court or arbitration or other dispute resolution costs) sustained by Contractor on or in connection with any other project or anticipated project.
- E. Contractor shall not be entitled to an adjustment in Contract Price or Contract Times for delays within the control of Contractor. Delays attributable to and within the control of a Subcontractor or Supplier shall be deemed to be delays within the control of Contractor.

## **ARTICLE 13 – TESTS AND INSPECTIONS; CORRECTION, REMOVAL OR ACCEPTANCE OF DEFECTIVE WORK**

### 13.01 *Notice of Defects*

- A. Prompt notice of all defective Work of which Owner or Engineer has actual knowledge will be given to Contractor. Defective Work may be rejected, corrected, or accepted as provided in this Article 13.

### 13.02 *Access to Work*

- A. Owner, Engineer, their consultants and other representatives and personnel of Owner, independent testing laboratories, and governmental agencies with jurisdictional interests will have access to the Site and the Work at reasonable times for their observation, inspection, and



testing. Contractor shall provide them proper and safe conditions for such access and advise them of Contractor's safety procedures and programs so that they may comply therewith as applicable.

### 13.03 *Tests and Inspections*

- A. Contractor shall give Engineer timely notice of readiness of the Work for all required inspections, tests, or approvals and shall cooperate with inspection and testing personnel to facilitate required inspections or tests.
- B. Owner shall employ and pay for the services of an independent testing laboratory to perform all inspections, tests, or approvals required by the Contract Documents except:
  - 1. for inspections, tests, or approvals covered by Paragraphs 13.03.C and 13.03.D below;
  - 2. that costs incurred in connection with tests or inspections conducted pursuant to Paragraph 13.04.B shall be paid as provided in Paragraph 13.04.C; and
  - 3. as otherwise specifically provided in the Contract Documents.
- C. If Laws or Regulations of any public body having jurisdiction require any Work (or part thereof) specifically to be inspected, tested, or approved by an employee or other representative of such public body, Contractor shall assume full responsibility for arranging and obtaining such inspections, tests, or approvals, pay all costs in connection therewith, and furnish Engineer the required certificates of inspection or approval.
- D. Contractor shall be responsible for arranging and obtaining and shall pay all costs in connection with any inspections, tests, or approvals required for Owner's and Engineer's acceptance of materials or equipment to be incorporated in the Work; or acceptance of materials, mix designs, or equipment submitted for approval prior to Contractor's purchase thereof for incorporation in the Work. Such inspections, tests, or approvals shall be performed by organizations acceptable to Owner and Engineer.
- E. If any Work (or the work of others) that is to be inspected, tested, or approved is covered by Contractor without written concurrence of Engineer, Contractor shall, if requested by Engineer, uncover such Work for observation.
- F. Uncovering Work as provided in Paragraph 13.03.E shall be at Contractor's expense unless Contractor has given Engineer timely notice of Contractor's intention to cover the same and Engineer has not acted with reasonable promptness in response to such notice.

### 13.04 *Uncovering Work*

- A. If any Work is covered contrary to the written request of Engineer, it must, if requested by Engineer, be uncovered for Engineer's observation and replaced at Contractor's expense.

- B. If Engineer considers it necessary or advisable that covered Work be observed by Engineer or inspected or tested by others, Contractor, at Engineer's request, shall uncover, expose, or otherwise make available for observation, inspection, or testing as Engineer may require, that portion of the Work in question, furnishing all necessary labor, material, and equipment.
- C. If it is found that the uncovered Work is defective, Contractor shall pay all claims, costs, losses, and damages (including but not limited to all fees and charges of engineers, architects, attorneys, and other professionals and all court or arbitration or other dispute resolution costs) arising out of or relating to such uncovering, exposure, observation, inspection, and testing, and of satisfactory replacement or reconstruction (including but not limited to all costs of repair or replacement of work of others); and Owner shall be entitled to an appropriate decrease in the Contract Price. If the parties are unable to agree as to the amount thereof, Owner may make a Claim therefor as provided in Paragraph 10.05.
- D. If the uncovered Work is not found to be defective, Contractor shall be allowed an increase in the Contract Price or an extension of the Contract Times, or both, directly attributable to such uncovering, exposure, observation, inspection, testing, replacement, and reconstruction. If the parties are unable to agree as to the amount or extent thereof, Contractor may make a Claim therefor as provided in Paragraph 10.05.

13.05 *Owner May Stop the Work*

- A. If the Work is defective, or Contractor fails to supply sufficient skilled workers or suitable materials or equipment, or fails to perform the Work in such a way that the completed Work will conform to the Contract Documents, Owner may order Contractor to stop the Work, or any portion thereof, until the cause for such order has been eliminated; however, this right of Owner to stop the Work shall not give rise to any duty on the part of Owner to exercise this right for the benefit of Contractor, any Subcontractor, any Supplier, any other individual or entity, or any surety for, or employee or agent of any of them.

13.06 *Correction or Removal of Defective Work*

- A. Promptly after receipt of written notice, Contractor shall correct all defective Work, whether or not fabricated, installed, or completed, or, if the Work has been rejected by Engineer, remove it from the Project and replace it with Work that is not defective. Contractor shall pay all claims, costs, losses, and damages (including but not limited to all fees and charges of engineers, architects, attorneys, and other professionals and all court or arbitration or other dispute resolution costs) arising out of or relating to such correction or removal (including but not limited to all costs of repair or replacement of work of others).
- B. When correcting defective Work under the terms of this Paragraph 13.06 or Paragraph 13.07, Contractor shall take no action that would void or otherwise impair Owner's special warranty and guarantee, if any, on said Work.

13.07 *Correction Period*

- A. If within one year after the date of Substantial Completion (or such longer period of time as may be prescribed by the terms of any applicable special guarantee required by the Contract

Documents) or by any specific provision of the Contract Documents, any Work is found to be defective, or if the repair of any damages to the land or areas made available for Contractor's use by Owner or permitted by Laws and Regulations as contemplated in Paragraph 6.11.A is found to be defective, Contractor shall promptly, without cost to Owner and in accordance with Owner's written instructions:

1. repair such defective land or areas; or
  2. correct such defective Work; or
  3. if the defective Work has been rejected by Owner, remove it from the Project and replace it with Work that is not defective, and
  4. satisfactorily correct or repair or remove and replace any damage to other Work, to the work of others or other land or areas resulting therefrom.
- B. If Contractor does not promptly comply with the terms of Owner's written instructions, or in an emergency where delay would cause serious risk of loss or damage, Owner may have the defective Work corrected or repaired or may have the rejected Work removed and replaced. All claims, costs, losses, and damages (including but not limited to all fees and charges of engineers, architects, attorneys, and other professionals and all court or arbitration or other dispute resolution costs) arising out of or relating to such correction or repair or such removal and replacement (including but not limited to all costs of repair or replacement of work of others) will be paid by Contractor.
- C. In special circumstances where a particular item of equipment is placed in continuous service before Substantial Completion of all the Work, the correction period for that item may start to run from an earlier date if so provided in the Specifications.
- D. Where defective Work (and damage to other Work resulting therefrom) has been corrected or removed and replaced under this Paragraph 13.07, the correction period hereunder with respect to such Work will be extended for an additional period of one year after such correction or removal and replacement has been satisfactorily completed.
- E. Contractor's obligations under this Paragraph 13.07 are in addition to any other obligation or warranty. The provisions of this Paragraph 13.07 shall not be construed as a substitute for, or a waiver of, the provisions of any applicable statute of limitation or repose.

#### 13.08 *Acceptance of Defective Work*

- A. If, instead of requiring correction or removal and replacement of defective Work, Owner (and, prior to Engineer's recommendation of final payment, Engineer) prefers to accept it, Owner may do so. Contractor shall pay all claims, costs, losses, and damages (including but not limited to all fees and charges of engineers, architects, attorneys, and other professionals and all court or arbitration or other dispute resolution costs) attributable to Owner's evaluation of and determination to accept such defective Work (such costs to be approved by Engineer as to reasonableness) and for the diminished value of the Work to the extent not otherwise paid by Contractor pursuant to this sentence. If any such acceptance occurs prior to Engineer's

recommendation of final payment, a Change Order will be issued incorporating the necessary revisions in the Contract Documents with respect to the Work, and Owner shall be entitled to an appropriate decrease in the Contract Price, reflecting the diminished value of Work so accepted. If the parties are unable to agree as to the amount thereof, Owner may make a Claim therefor as provided in Paragraph 10.05. If the acceptance occurs after such recommendation, an appropriate amount will be paid by Contractor to Owner.

13.09 *Owner May Correct Defective Work*

- A. If Contractor fails within a reasonable time after written notice from Engineer to correct defective Work, or to remove and replace rejected Work as required by Engineer in accordance with Paragraph 13.06.A, or if Contractor fails to perform the Work in accordance with the Contract Documents, or if Contractor fails to comply with any other provision of the Contract Documents, Owner may, after seven days written notice to Contractor, correct, or remedy any such deficiency.
- B. In exercising the rights and remedies under this Paragraph 13.09, Owner shall proceed expeditiously. In connection with such corrective or remedial action, Owner may exclude Contractor from all or part of the Site, take possession of all or part of the Work and suspend Contractor's services related thereto, take possession of Contractor's tools, appliances, construction equipment and machinery at the Site, and incorporate in the Work all materials and equipment stored at the Site or for which Owner has paid Contractor but which are stored elsewhere. Contractor shall allow Owner, Owner's representatives, agents and employees, Owner's other contractors, and Engineer and Engineer's consultants access to the Site to enable Owner to exercise the rights and remedies under this Paragraph.
- C. All claims, costs, losses, and damages (including but not limited to all fees and charges of engineers, architects, attorneys, and other professionals and all court or arbitration or other dispute resolution costs) incurred or sustained by Owner in exercising the rights and remedies under this Paragraph 13.09 will be charged against Contractor, and a Change Order will be issued incorporating the necessary revisions in the Contract Documents with respect to the Work; and Owner shall be entitled to an appropriate decrease in the Contract Price. If the parties are unable to agree as to the amount of the adjustment, Owner may make a Claim therefor as provided in Paragraph 10.05. Such claims, costs, losses and damages will include but not be limited to all costs of repair, or replacement of work of others destroyed or damaged by correction, removal, or replacement of Contractor's defective Work.
- D. Contractor shall not be allowed an extension of the Contract Times because of any delay in the performance of the Work attributable to the exercise by Owner of Owner's rights and remedies under this Paragraph 13.09.

**ARTICLE 14 – PAYMENTS TO CONTRACTOR AND COMPLETION**

14.01 *Schedule of Values*

- A. The Schedule of Values established as provided in Paragraph 2.07.A will serve as the basis for progress payments and will be incorporated into a form of Application for Payment acceptable to Engineer. Progress payments on account of Unit Price Work will be based on the number of units completed.

## 14.02 *Progress Payments*

### A. *Applications for Payments:*

1. At least 20 days before the date established in the Agreement for each progress payment (but not more often than once a month), Contractor shall submit to Engineer for review an Application for Payment filled out and signed by Contractor covering the Work completed as of the date of the Application and accompanied by such supporting documentation as is required by the Contract Documents. If payment is requested on the basis of materials and equipment not incorporated in the Work but delivered and suitably stored at the Site or at another location agreed to in writing, the Application for Payment shall also be accompanied by a bill of sale, invoice, or other documentation warranting that Owner has received the materials and equipment free and clear of all Liens and evidence that the materials and equipment are covered by appropriate property insurance or other arrangements to protect Owner's interest therein, all of which must be satisfactory to Owner.
2. Beginning with the second Application for Payment, each Application shall include an affidavit of Contractor stating that all previous progress payments received on account of the Work have been applied on account to discharge Contractor's legitimate obligations associated with prior Applications for Payment.
3. The amount of retainage with respect to progress payments will be as stipulated in the Agreement.

### B. *Review of Applications:*

1. Engineer will, within 10 days after receipt of each Application for Payment, either indicate in writing a recommendation of payment and present the Application to Owner or return the Application to Contractor indicating in writing Engineer's reasons for refusing to recommend payment. In the latter case, Contractor may make the necessary corrections and resubmit the Application.
2. Engineer's recommendation of any payment requested in an Application for Payment will constitute a representation by Engineer to Owner, based on Engineer's observations of the executed Work as an experienced and qualified design professional, and on Engineer's review of the Application for Payment and the accompanying data and schedules, that to the best of Engineer's knowledge, information and belief:
  - a. the Work has progressed to the point indicated;
  - b. the quality of the Work is generally in accordance with the Contract Documents (subject to an evaluation of the Work as a functioning whole prior to or upon Substantial Completion, the results of any subsequent tests called for in the Contract Documents, a final determination of quantities and classifications for Unit Price Work under Paragraph 9.07, and any other qualifications stated in the recommendation); and
  - c. the conditions precedent to Contractor's being entitled to such payment appear to have been fulfilled in so far as it is Engineer's responsibility to observe the Work.

3. By recommending any such payment Engineer will not thereby be deemed to have represented that:
  - a. inspections made to check the quality or the quantity of the Work as it has been performed have been exhaustive, extended to every aspect of the Work in progress, or involved detailed inspections of the Work beyond the responsibilities specifically assigned to Engineer in the Contract Documents; or
  - b. there may not be other matters or issues between the parties that might entitle Contractor to be paid additionally by Owner or entitle Owner to withhold payment to Contractor.
4. Neither Engineer's review of Contractor's Work for the purposes of recommending payments nor Engineer's recommendation of any payment, including final payment, will impose responsibility on Engineer:
  - a. to supervise, direct, or control the Work, or
  - b. for the means, methods, techniques, sequences, or procedures of construction, or the safety precautions and programs incident thereto, or
  - c. for Contractor's failure to comply with Laws and Regulations applicable to Contractor's performance of the Work, or
  - d. to make any examination to ascertain how or for what purposes Contractor has used the moneys paid on account of the Contract Price, or
  - e. to determine that title to any of the Work, materials, or equipment has passed to Owner free and clear of any Liens.
5. Engineer may refuse to recommend the whole or any part of any payment if, in Engineer's opinion, it would be incorrect to make the representations to Owner stated in Paragraph 14.02.B.2. Engineer may also refuse to recommend any such payment or, because of subsequently discovered evidence or the results of subsequent inspections or tests, revise or revoke any such payment recommendation previously made, to such extent as may be necessary in Engineer's opinion to protect Owner from loss because:
  - a. the Work is defective, or completed Work has been damaged, requiring correction or replacement;
  - b. the Contract Price has been reduced by Change Orders;
  - c. Owner has been required to correct defective Work or complete Work in accordance with Paragraph 13.09; or
  - d. Engineer has actual knowledge of the occurrence of any of the events enumerated in Paragraph 15.02.A.

C. *Payment Becomes Due:*

1. Ten days after presentation of the Application for Payment to Owner with Engineer's recommendation, the amount recommended will (subject to the provisions of Paragraph 14.02.D) become due, and when due will be paid by Owner to Contractor.

D. *Reduction in Payment:*

1. Owner may refuse to make payment of the full amount recommended by Engineer because:
  - a. claims have been made against Owner on account of Contractor's performance or furnishing of the Work;
  - b. Liens have been filed in connection with the Work, except where Contractor has delivered a specific bond satisfactory to Owner to secure the satisfaction and discharge of such Liens;
  - c. there are other items entitling Owner to a set-off against the amount recommended; or
  - d. Owner has actual knowledge of the occurrence of any of the events enumerated in Paragraphs 14.02.B.5.a through 14.02.B.5.c or Paragraph 15.02.A.
2. If Owner refuses to make payment of the full amount recommended by Engineer, Owner will give Contractor immediate written notice (with a copy to Engineer) stating the reasons for such action and promptly pay Contractor any amount remaining after deduction of the amount so withheld. Owner shall promptly pay Contractor the amount so withheld, or any adjustment thereto agreed to by Owner and Contractor, when Contractor remedies the reasons for such action.
3. Upon a subsequent determination that Owner's refusal of payment was not justified, the amount wrongfully withheld shall be treated as an amount due as determined by Paragraph 14.02.C.1 and subject to interest as provided in the Agreement.

14.03 *Contractor's Warranty of Title*

- A. Contractor warrants and guarantees that title to all Work, materials, and equipment covered by any Application for Payment, whether incorporated in the Project or not, will pass to Owner no later than the time of payment free and clear of all Liens.

14.04 *Substantial Completion*

- A. When Contractor considers the entire Work ready for its intended use Contractor shall notify Owner and Engineer in writing that the entire Work is substantially complete (except for items specifically listed by Contractor as incomplete) and request that Engineer issue a certificate of Substantial Completion.

- B. Promptly after Contractor's notification, Owner, Contractor, and Engineer shall make an inspection of the Work to determine the status of completion. If Engineer does not consider the Work substantially complete, Engineer will notify Contractor in writing giving the reasons therefor.
- C. If Engineer considers the Work substantially complete, Engineer will deliver to Owner a tentative certificate of Substantial Completion which shall fix the date of Substantial Completion. There shall be attached to the certificate a tentative list of items to be completed or corrected before final payment. Owner shall have seven days after receipt of the tentative certificate during which to make written objection to Engineer as to any provisions of the certificate or attached list. If, after considering such objections, Engineer concludes that the Work is not substantially complete, Engineer will, within 14 days after submission of the tentative certificate to Owner, notify Contractor in writing, stating the reasons therefor. If, after consideration of Owner's objections, Engineer considers the Work substantially complete, Engineer will, within said 14 days, execute and deliver to Owner and Contractor a definitive certificate of Substantial Completion (with a revised tentative list of items to be completed or corrected) reflecting such changes from the tentative certificate as Engineer believes justified after consideration of any objections from Owner.
- D. At the time of delivery of the tentative certificate of Substantial Completion, Engineer will deliver to Owner and Contractor a written recommendation as to division of responsibilities pending final payment between Owner and Contractor with respect to security, operation, safety, and protection of the Work, maintenance, heat, utilities, insurance, and warranties and guarantees. Unless Owner and Contractor agree otherwise in writing and so inform Engineer in writing prior to Engineer's issuing the definitive certificate of Substantial Completion, Engineer's aforesaid recommendation will be binding on Owner and Contractor until final payment.
- E. Owner shall have the right to exclude Contractor from the Site after the date of Substantial Completion subject to allowing Contractor reasonable access to remove its property and complete or correct items on the tentative list.

#### 14.05 *Partial Utilization*

- A. Prior to Substantial Completion of all the Work, Owner may use or occupy any substantially completed part of the Work which has specifically been identified in the Contract Documents, or which Owner, Engineer, and Contractor agree constitutes a separately functioning and usable part of the Work that can be used by Owner for its intended purpose without significant interference with Contractor's performance of the remainder of the Work, subject to the following conditions:
  - 1. Owner at any time may request Contractor in writing to permit Owner to use or occupy any such part of the Work which Owner believes to be ready for its intended use and substantially complete. If and when Contractor agrees that such part of the Work is substantially complete, Contractor, Owner, and Engineer will follow the procedures of Paragraph 14.04.A through D for that part of the Work.
  - 2. Contractor at any time may notify Owner and Engineer in writing that Contractor considers any such part of the Work ready for its intended use and substantially complete and request Engineer to issue a certificate of Substantial Completion for that part of the Work.



3. Within a reasonable time after either such request, Owner, Contractor, and Engineer shall make an inspection of that part of the Work to determine its status of completion. If Engineer does not consider that part of the Work to be substantially complete, Engineer will notify Owner and Contractor in writing giving the reasons therefor. If Engineer considers that part of the Work to be substantially complete, the provisions of Paragraph 14.04 will apply with respect to certification of Substantial Completion of that part of the Work and the division of responsibility in respect thereof and access thereto.
4. No use or occupancy or separate operation of part of the Work may occur prior to compliance with the requirements of Paragraph 5.10 regarding property insurance.

#### 14.06 *Final Inspection*

- A. Upon written notice from Contractor that the entire Work or an agreed portion thereof is complete, Engineer will promptly make a final inspection with Owner and Contractor and will notify Contractor in writing of all particulars in which this inspection reveals that the Work is incomplete or defective. Contractor shall immediately take such measures as are necessary to complete such Work or remedy such deficiencies.

#### 14.07 *Final Payment*

##### A. *Application for Payment:*

1. After Contractor has, in the opinion of Engineer, satisfactorily completed all corrections identified during the final inspection and has delivered, in accordance with the Contract Documents, all maintenance and operating instructions, schedules, guarantees, bonds, certificates or other evidence of insurance, certificates of inspection, marked-up record documents (as provided in Paragraph 6.12), and other documents, Contractor may make application for final payment following the procedure for progress payments.
2. The final Application for Payment shall be accompanied (except as previously delivered) by:
  - a. all documentation called for in the Contract Documents, including but not limited to the evidence of insurance required by Paragraph 5.04.B.6;
  - b. consent of the surety, if any, to final payment;
  - c. a list of all Claims against Owner that Contractor believes are unsettled; and
  - d. complete and legally effective releases or waivers (satisfactory to Owner) of all Lien rights arising out of or Liens filed in connection with the Work.
3. In lieu of the releases or waivers of Liens specified in Paragraph 14.07.A.2 and as approved by Owner, Contractor may furnish receipts or releases in full and an affidavit of Contractor that: (i) the releases and receipts include all labor, services, material, and equipment for which a Lien could be filed; and (ii) all payrolls, material and equipment bills, and other indebtedness connected with the Work for which Owner might in any way be responsible, or which might in any way result in liens or other burdens on Owner's property, have been paid

or otherwise satisfied. If any Subcontractor or Supplier fails to furnish such a release or receipt in full, Contractor may furnish a bond or other collateral satisfactory to Owner to indemnify Owner against any Lien.

*B. Engineer's Review of Application and Acceptance:*

1. If, on the basis of Engineer's observation of the Work during construction and final inspection, and Engineer's review of the final Application for Payment and accompanying documentation as required by the Contract Documents, Engineer is satisfied that the Work has been completed and Contractor's other obligations under the Contract Documents have been fulfilled, Engineer will, within ten days after receipt of the final Application for Payment, indicate in writing Engineer's recommendation of payment and present the Application for Payment to Owner for payment. At the same time Engineer will also give written notice to Owner and Contractor that the Work is acceptable subject to the provisions of Paragraph 14.09. Otherwise, Engineer will return the Application for Payment to Contractor, indicating in writing the reasons for refusing to recommend final payment, in which case Contractor shall make the necessary corrections and resubmit the Application for Payment.

*C. Payment Becomes Due:*

1. Thirty days after the presentation to Owner of the Application for Payment and accompanying documentation, the amount recommended by Engineer, less any sum Owner is entitled to set off against Engineer's recommendation, including but not limited to liquidated damages, will become due and will be paid by Owner to Contractor.

**14.08** *Final Completion Delayed*

- A. If, through no fault of Contractor, final completion of the Work is significantly delayed, and if Engineer so confirms, Owner shall, upon receipt of Contractor's final Application for Payment (for Work fully completed and accepted) and recommendation of Engineer, and without terminating the Contract, make payment of the balance due for that portion of the Work fully completed and accepted. If the remaining balance to be held by Owner for Work not fully completed or corrected is less than the retainage stipulated in the Agreement, and if bonds have been furnished as required in Paragraph 5.01, the written consent of the surety to the payment of the balance due for that portion of the Work fully completed and accepted shall be submitted by Contractor to Engineer with the Application for such payment. Such payment shall be made under the terms and conditions governing final payment, except that it shall not constitute a waiver of Claims.

**14.09** *Waiver of Claims*

A. The making and acceptance of final payment will constitute:

1. a waiver of all Claims by Owner against Contractor, except Claims arising from unsettled Liens, from defective Work appearing after final inspection pursuant to Paragraph 14.06, from failure to comply with the Contract Documents or the terms of any special guarantees

specified therein, or from Contractor's continuing obligations under the Contract Documents;  
and

2. a waiver of all Claims by Contractor against Owner other than those previously made in accordance with the requirements herein and expressly acknowledged by Owner in writing as still unsettled.

## ARTICLE 15 – SUSPENSION OF WORK AND TERMINATION

### 15.01 *Owner May Suspend Work*

- A. At any time and without cause, Owner may suspend the Work or any portion thereof for a period of not more than 90 consecutive days by notice in writing to Contractor and Engineer which will fix the date on which Work will be resumed. Contractor shall resume the Work on the date so fixed. Contractor shall be granted an adjustment in the Contract Price or an extension of the Contract Times, or both, directly attributable to any such suspension if Contractor makes a Claim therefor as provided in Paragraph 10.05.

### 15.02 *Owner May Terminate for Cause*

- A. The occurrence of any one or more of the following events will justify termination for cause:
  1. Contractor's persistent failure to perform the Work in accordance with the Contract Documents (including, but not limited to, failure to supply sufficient skilled workers or suitable materials or equipment or failure to adhere to the Progress Schedule established under Paragraph 2.07 as adjusted from time to time pursuant to Paragraph 6.04);
  2. Contractor's disregard of Laws or Regulations of any public body having jurisdiction;
  3. Contractor's repeated disregard of the authority of Engineer; or
  4. Contractor's violation in any substantial way of any provisions of the Contract Documents.
- B. If one or more of the events identified in Paragraph 15.02.A occur, Owner may, after giving Contractor (and surety) seven days written notice of its intent to terminate the services of Contractor:
  1. exclude Contractor from the Site, and take possession of the Work and of all Contractor's tools, appliances, construction equipment, and machinery at the Site, and use the same to the full extent they could be used by Contractor (without liability to Contractor for trespass or conversion);
  2. incorporate in the Work all materials and equipment stored at the Site or for which Owner has paid Contractor but which are stored elsewhere; and
  3. complete the Work as Owner may deem expedient.

- C. If Owner proceeds as provided in Paragraph 15.02.B, Contractor shall not be entitled to receive any further payment until the Work is completed. If the unpaid balance of the Contract Price exceeds all claims, costs, losses, and damages (including but not limited to all fees and charges of engineers, architects, attorneys, and other professionals and all court or arbitration or other dispute resolution costs) sustained by Owner arising out of or relating to completing the Work, such excess will be paid to Contractor. If such claims, costs, losses, and damages exceed such unpaid balance, Contractor shall pay the difference to Owner. Such claims, costs, losses, and damages incurred by Owner will be reviewed by Engineer as to their reasonableness and, when so approved by Engineer, incorporated in a Change Order. When exercising any rights or remedies under this Paragraph, Owner shall not be required to obtain the lowest price for the Work performed.
- D. Notwithstanding Paragraphs 15.02.B and 15.02.C, Contractor's services will not be terminated if Contractor begins within seven days of receipt of notice of intent to terminate to correct its failure to perform and proceeds diligently to cure such failure within no more than 30 days of receipt of said notice.
- E. Where Contractor's services have been so terminated by Owner, the termination will not affect any rights or remedies of Owner against Contractor then existing or which may thereafter accrue. Any retention or payment of moneys due Contractor by Owner will not release Contractor from liability.
- F. If and to the extent that Contractor has provided a performance bond under the provisions of Paragraph 5.01.A, the termination procedures of that bond shall supersede the provisions of Paragraphs 15.02.B and 15.02.C.

15.03 *Owner May Terminate For Convenience*

- A. Upon seven days written notice to Contractor and Engineer, Owner may, without cause and without prejudice to any other right or remedy of Owner, terminate the Contract. In such case, Contractor shall be paid for (without duplication of any items):
  - 1. completed and acceptable Work executed in accordance with the Contract Documents prior to the effective date of termination, including fair and reasonable sums for overhead and profit on such Work;
  - 2. expenses sustained prior to the effective date of termination in performing services and furnishing labor, materials, or equipment as required by the Contract Documents in connection with uncompleted Work, plus fair and reasonable sums for overhead and profit on such expenses;
  - 3. all claims, costs, losses, and damages (including but not limited to all fees and charges of engineers, architects, attorneys, and other professionals and all court or arbitration or other dispute resolution costs) incurred in settlement of terminated contracts with Subcontractors, Suppliers, and others; and
  - 4. reasonable expenses directly attributable to termination.

- B. Contractor shall not be paid on account of loss of anticipated profits or revenue or other economic loss arising out of or resulting from such termination.

15.04 *Contractor May Stop Work or Terminate*

- A. If, through no act or fault of Contractor, (i) the Work is suspended for more than 90 consecutive days by Owner or under an order of court or other public authority, or (ii) Engineer fails to act on any Application for Payment within 30 days after it is submitted, or (iii) Owner fails for 30 days to pay Contractor any sum finally determined to be due, then Contractor may, upon seven days written notice to Owner and Engineer, and provided Owner or Engineer do not remedy such suspension or failure within that time, terminate the Contract and recover from Owner payment on the same terms as provided in Paragraph 15.03.
- B. In lieu of terminating the Contract and without prejudice to any other right or remedy, if Engineer has failed to act on an Application for Payment within 30 days after it is submitted, or Owner has failed for 30 days to pay Contractor any sum finally determined to be due, Contractor may, seven days after written notice to Owner and Engineer, stop the Work until payment is made of all such amounts due Contractor, including interest thereon. The provisions of this Paragraph 15.04 are not intended to preclude Contractor from making a Claim under Paragraph 10.05 for an adjustment in Contract Price or Contract Times or otherwise for expenses or damage directly attributable to Contractor's stopping the Work as permitted by this Paragraph.

**ARTICLE 16 – DISPUTE RESOLUTION**

16.01 *Methods and Procedures*

- A. Either Owner or Contractor may request mediation of any Claim submitted to Engineer for a decision under Paragraph 10.05 before such decision becomes final and binding. The mediation will be governed by the Construction Industry Mediation Rules of the American Arbitration Association in effect as of the Effective Date of the Agreement. The request for mediation shall be submitted in writing to the American Arbitration Association and the other party to the Contract. Timely submission of the request shall stay the effect of Paragraph 10.05.E.
- B. Owner and Contractor shall participate in the mediation process in good faith. The process shall be concluded within 60 days of filing of the request. The date of termination of the mediation shall be determined by application of the mediation rules referenced above.
- C. If the Claim is not resolved by mediation, Engineer's action under Paragraph 10.05.C or a denial pursuant to Paragraphs 10.05.C.3 or 10.05.D shall become final and binding 30 days after termination of the mediation unless, within that time period, Owner or Contractor:
  - 1. elects in writing to invoke any dispute resolution process provided for in the Supplementary Conditions; or
  - 2. agrees with the other party to submit the Claim to another dispute resolution process; or
  - 3. gives written notice to the other party of the intent to submit the Claim to a court of competent jurisdiction.

## ARTICLE 17 – MISCELLANEOUS

### 17.01 *Giving Notice*

- A. Whenever any provision of the Contract Documents requires the giving of written notice, it will be deemed to have been validly given if:
  - 1. delivered in person to the individual or to a member of the firm or to an officer of the corporation for whom it is intended; or
  - 2. delivered at or sent by registered or certified mail, postage prepaid, to the last business address known to the giver of the notice.

### 17.02 *Computation of Times*

- A. When any period of time is referred to in the Contract Documents by days, it will be computed to exclude the first and include the last day of such period. If the last day of any such period falls on a Saturday or Sunday or on a day made a legal holiday by the law of the applicable jurisdiction, such day will be omitted from the computation.

### 17.03 *Cumulative Remedies*

- A. The duties and obligations imposed by these General Conditions and the rights and remedies available hereunder to the parties hereto are in addition to, and are not to be construed in any way as a limitation of, any rights and remedies available to any or all of them which are otherwise imposed or available by Laws or Regulations, by special warranty or guarantee, or by other provisions of the Contract Documents. The provisions of this Paragraph will be as effective as if repeated specifically in the Contract Documents in connection with each particular duty, obligation, right, and remedy to which they apply.

### 17.04 *Survival of Obligations*

- A. All representations, indemnifications, warranties, and guarantees made in, required by, or given in accordance with the Contract Documents, as well as all continuing obligations indicated in the Contract Documents, will survive final payment, completion, and acceptance of the Work or termination or completion of the Contract or termination of the services of Contractor.

### 17.05 *Controlling Law*

- A. This Contract is to be governed by the law of the state in which the Project is located.

### 17.06 *Headings*

- A. Article and paragraph headings are inserted for convenience only and do not constitute parts of these General Conditions.

## SECTION 00800 – SUPPLEMENTARY CONDITIONS

These Supplementary Conditions amend or supplement the Standard General Conditions of the Construction Contract (EJCDC C-700) (2007 Edition) and other provisions of the Contract Documents as indicated below. All provisions which are not so amended or supplemented remain in full force and effect.

### ARTICLE 1 – DEFINITIONS AND TERMINOLOGY

1.01 Defined Terms

1.01.A.12 Replace in its entirety with the following:

“12. Contract Documents – The Contract Documents establish the rights and obligations of the parties and include the Agreement, Addenda (which pertain to the Contract Documents), Contractor’s Bid (including documentation accompanying the Bid and any post Bid documentation submitted prior to the Notice of Award) when attached as an exhibit to the Agreement, the Notice to Proceed, the Bonds, these General Conditions, the Supplementary Conditions, the Specifications and the Drawings as the same are more specifically identified in the Agreement, together with all Written Amendments, Change Orders, Work Change Directives, Field Orders, and Engineer’s written interpretations and clarifications issued on or after the Effective Date of the Agreement. Approved Shop Drawings and the reports and drawings of subsurface and physical conditions are not Contract Documents. Only printed or Hardcopies of the items listed in this paragraph are Contract Documents. Files in electronic format of text, data, graphics, and the like that may be furnished by Owner to Contractor are not Contract Documents”.

1.01.A.44 First sentence, change: “in the opinion of the Engineer”, to “in the opinion of Engineer and Owner”.

1.02 Terminology

Delete 1.02.E and replace with the following:

1.02.E The words “furnish”, “furnish and install”, “install”, and “provide” or words with similar meaning shall be interpreted, unless otherwise specifically stated, to mean “furnish and install complete in place and ready for service”.

Add the following:

1.02.G The terms used in these Supplementary Conditions which are defined in the Standard General Conditions of the Construction Contract (EJCDC C-700, (2007 Edition) have the meanings assigned to them in the General Conditions.

### ARTICLE 2 – PRELIMINARY MATTERS

Add the following:

2.00 Execution of Agreement

2.00.A At least six (6) counterparts of the Agreement will be executed and delivered by the Contractor to the OWNER within fifteen (15) days of the Notice of Award and receipt of the Contract Documents by the Contractor for execution; and OWNER will execute and deliver one counterpart to Contractor within ten (10) days of receipt of the executed Agreement from Contractor.

2.01 Delivery of Bonds and Evidence of Insurance

2.01.B Replace "Before any Work at the Site is started, Contractor and Owner shall each deliver to the other" with "When Contractor delivers the executed counterparts of the Agreement to the Owner, Contractor shall deliver to the Owner", and replace "and Owner respectively are" with "is".

2.02 Copies of Documents

2.02A Revise as follows:

Owner shall furnish to Contractor up to ~~ten~~ three printed or hard copies of the Drawings and Project Manual. Additional copies will be furnished upon request at the cost of reproduction.

2.03 Commencement of Contract Times; Notice to Proceed:

2.03.A Delete in its entirety and substitute the following:

2.03.A The Contract Time will commence to run on the day indicated in the Notice to Proceed; but in no event will the Contract Time commence to run later than the ninetieth day after the day of Bid opening or the thirtieth day after the effective date of the Agreement. By mutual consent of the parties to the Contract, these time limits may be changed.

### ARTICLE 3 – CONTRACT DOCUMENTS: INTENT, AMENDING AND REUSE

3.01 Intent

Add the following:

3.01.D It is the intent of the Specification and Contract Documents to obtain an operable Project. Equipment, components, systems, etc., therein shall be made operable by the Contractor.

3.01.E The Contract Drawings may be supplemented from time to time with additional Drawings by the Engineer as may be required to illustrate the work or, as the work progresses, with additional Drawings, by the Contractor, subject to the approval of the Engineer. Supplementary Drawings, when issued by the Engineer or by the Contractor, after approval by the Engineer, shall be furnished in sufficient quantity to all those who, in the opinion of the Engineer, are affected by such Drawings.

3.03 Reporting and Resolving Discrepancies

Add the following:

3.03.B.2 In resolving such conflicts, errors and discrepancies, the Contract Documents shall be given precedence in the following order:

- a. Agreement
- b. Field and Change Orders
- c. Addenda
- d. Special Conditions
- e. Instruction to Bidders
- f. General Conditions
- g. Project Specifications and Drawings
- h. LFUCG standard specifications and standard details

Figure dimensions on drawings shall govern over scale dimensions and detailed Drawings shall govern over general Drawings.



ARTICLE 4 – AVAILABILITY OF LANDS; SUBSURFACE AND PHYSICAL CONDITIONS; HAZARDOUS ENVIRONMENTAL CONDITIONS; REFERENCE POINTS.

- 4.02 Subsurface and Physical Conditions
- 4.02.A Delete: “the Supplementary Conditions”, and substitute “Section 00320 – Geotechnical Data”.
- 4.02.B Second sentence, delete: “Supplementary Conditions” and substitute “Specifications and Contract Drawings”.
- 4.04 Underground Facilities

Add the following:

- 4.04.B.3 The Owner, Engineer, and Engineer’s Consultants shall not be liable to Contractor for any claims, costs, losses or damages incurred or sustained by Contractor on or in connection with any other project or anticipated project.
- 4.06 Hazardous Environmental Condition at Site
- 4.06.A First sentence, delete “Supplementary Conditions” and substitute “Section 00300 – Information Available To Bidders.”
- 4.06.B Second sentence, delete “Supplementary Conditions: and substitute “Specifications and Contract Drawings.”
- 4.06.G First sentence, insert “Kentucky” between “by” and “Laws”.

Add the following at the end of this section: “The parties understand and acknowledge that no Kentucky case, statute, or Constitutional provision authorizes a local government to indemnify a contractor and that this contract provision may be unenforceable.

ARTICLE 5 – BONDS AND INSURANCE

Delete Article 5 in its entirety and substitute the following:

- 5.01 Performance and Payment Bonds
- 5.01A Concurrent with execution of the Agreement and within fifteen (15) days of the Notice of Award, the successful Contractor shall procure, execute and deliver to the OWNER and maintain, at his own cost and expense, the following bonds in the forms attached, of a surety company approved by the State of Kentucky as a Surety:
- 5.01.B Performance Bond – in an amount not less than 100% of the total amount payable to the Contractor by the terms of the Contract as security for the faithful performance of the work. Bond must be valid until one (1) year after the date of issuance of the Certificate of Substantial Completion.
- 5.01.C Payment Bond – in an amount not less than 100% of the total amount payable to the Contractor by the terms of the Contract as security for the payment of all persons performing labor and furnishing material in connection with the work. Bond must be valid until one (1) year after date of issuance of the Certificate of Substantial Completion.
- 5.01.D All Bonds signed by an agent must be accompanied by a certified copy of the authority to act.

- 5.01.E If the Surety on any Bond furnished by the Contractor is declared bankrupt or becomes insolvent or its right to do business in the State of Kentucky is revoked, the Contractor shall within five (5) days thereafter substitute another Bond or Surety, both of which shall be acceptable to the OWNER.
- 5.02 Insurance Requirements  
See Section 00600 – Bonds and Certificates for Insurance Requirements.
- 5.03 Contractor's Liability Insurance  
See Section 00600 – Bonds and Certificates for Insurance Requirements.
- 5.04 Indemnification Agreement  
See Section 00600 – Bonds and Certificates for Indemnification.

#### ARTICLE 6 – CONTRACTOR'S RESPONSIBILITIES

- 6.06 Concerning Subcontractors, Suppliers and Others
- 6.06.B First sentence, delete: "If the Supplementary Conditions", and substitute "The Bid Form". The seventh line, delete "Supplementary Conditions", and substitute "Bid Form".
- 6.06.G Delete in its entirety and substitute the following:
- 6.06.G All work performed for Contractor by a Subcontractor shall be pursuant to an appropriate agreement between the Contractor and Subcontractor. The Subcontractor shall not commence work until Contractor has obtained all insurance as required by Paragraphs 5.02 through 5.03 inclusive.
- 6.07 Patent Fees and Royalties
- 6.07 Delete 6.07.A, 6.07.B, and 6.07.C in their entirety and substitute the following:
- 6.07.A Contractor shall pay all license fees and royalties and assume all costs incident to the use in the performance of the Work of any invention, design, process, products or device which is the subject of patent rights or copyrights held by others. Contractor shall indemnify and hold harmless OWNER and Engineer and anyone directly or indirectly employed by either of them from and against all claims, damages, losses and expenses, including attorney's fees, arising out of any infringement of patent rights or copyrights incident to the use in the performance of the Work or furnished by him in fulfillment of the requirements of this Contract. In the event of any claim or action by law on account of such patents or fees, it is agreed that the OWNER may retain out of the monies which are or which may become due the Contractor under this Contract, a sum of money sufficient to protect itself against loss, and to retain the same until said claims are paid or are satisfactorily adjusted.
- 6.08 Permits
- 6.08.A Third sentence of paragraph delete, "or if there are no Bids.....to the Work.", and substitute "and the Contractor shall pay all charges of utility owners for connections to the Work."
- 6.09 Laws and Regulations
- 6.09.B Delete 6.09B in its entirety and substitute the following:
- 6.09.B If Contractor observes that the Specifications or Drawings are at variance with any Laws or Regulations, he shall give Engineer prompt written notice thereof. If Contractor performs

any Work knowing it to be contrary to such Laws or Regulations, and without such notice to Engineer, he shall bear all costs arising therefrom. The Contractor shall, at all times, observe and comply with and shall cause all his agents and employees and all his Subcontractors to observe and comply with all such existing Laws or Regulations, and shall protect and indemnify the OWNER and the Engineer and the municipalities in which work is being performed, and their officers and agents against any claim, civil penalty, fine or liability arising from or based on the violation of any such Law or Regulation, whether by himself or his employees or any of his Subcontractors.

6.13 Safety and Protection

6.13.B First sentence, after "CONTRACTOR" add the following:

", subject to provisions 6.09.B,"

6.19 Contractor's General Warranty and Guarantee

6.19.A After the first sentence of Section 6.19.A add the following:

"All materials or equipment delivered to the site shall be accompanied by certificates, signed by an authorized officer of the supplier, and notarized guaranteeing that the materials or equipment conform to specification requirements, Such certificates shall be immediately turned over to the Engineer. Materials or equipment delivered to the site without such certificates will be subject to rejection. The warranty and guarantee period shall be for a period of one (1) year, or such longer period of time as may be prescribed by Law, from the date of Substantial Completion."

6.20 Indemnification

6.20.A First sentence, after "...claims, costs" add the following:

", civil penalties, fines,"

6.20.C Add the following:

6.30.C.3 Nothing in the Contract Documents shall create or give to third parties any claim or right of action against the Contractor, the OWNER or the Engineer beyond such as may legally exist irrespective of the Contract.

#### ARTICLE 7 – OTHER WORK AT THE SITE

7.02 Coordination

Delete in its entirety.

7.03 Legal Relationships

7.03.B Delete "Owner and".

7.03.C Delete "Owner and".

#### ARTICLE 8 – OWNER'S RESPONSIBILITIES

8.02 Replacement of Engineer

8.02.A Delete in its entirety.

- 8.06 Insurance
- 8.06.A Delete in its entirety.
- 8.11 Evidence of Financial Arrangements
- 8.11.A Delete in its entirety.

#### ARTICLE 9 – ENGINEER'S STATUS DURING CONSTRUCTION

- 9.01 OWNER'S Representative
- 9.01.A Delete in its entirety and substitute the following:
- 9.01.A Engineer will be the OWNER'S representative during the construction period, and his instructions shall be carried into effect promptly and efficiently.
- 9.03 Project Representative

Add the following:

- 9.03.B The Resident Project Representative will serve as the Engineer's liaison with the Contractor, working principally through the Contractor's resident superintendent to assist him in understanding the intent of the Contract Documents.
- 9.03.C The Resident Project Representative shall conduct on-site observations of the work in progress to confirm that the work is proceeding in accordance with the Contract Documents. He will verify that tests, equipment and systems start-ups and operating maintenance instructions are conducted as required by the Contract Documents. He will have the authority to disapprove or reject defective work in accordance with Article 13.
- 9.09 Limitations on Engineer's Authority and Responsibilities

Add the following:

- 9.09.F Except upon written instructions of the Engineer, the Resident Project Representative:
  1. Shall not authorize any deviation from the Contract Documents or approve any substitute materials or equipment.
  2. Shall not exceed limitations of Engineer's authority as set forth in the Contract Documents.
  3. Shall not undertake any of the responsibilities of Contractor, Subcontractors, or Contractor's superintendent, or expedite the Work.
  4. Shall not advise on or issue directions relative to any aspect of the means, methods, techniques, sequences or procedures of construction unless such is specifically called for in the Contract.
  5. Shall not advise on or issue directions as to safety precautions and programs in connection with the Work.

#### ARTICLE 11 – COST OF THE WORK; ALLOWANCES, UNIT PRICE WORK

- 11.01 Cost of the Work

- 11.01.A Last sentence, following "...in Paragraph 11.01.B," insert the following:  
"or claims for extra cost shall be considered based on an escalation of labor costs throughout the period of the Contract,"
- 11.01.A.2 Add the following at the end of the paragraph:  
"No claims for extra cost shall be considered based on an escalation of material costs throughout the period of the Contract."
- 11.01.A.3 Delete second sentence "If required...be acceptable."
- 11.01.A.4 Delete in its entirety.
- 11.01.A.5.a Delete in its entirety.
- 11.01.A.5.c Add the following before last sentence of paragraph:  
"These rates shall include all fuel, lubricants, insurance, etc. Equipment rental charges shall not exceed the prorated monthly rental rates listed in the current edition of the 'Compilation of Rental Rates for Construction Equipment' as published by the Associated Equipment Distributors. Charges per hour shall be determined by dividing the monthly rates by 176."
- 11.01.A.5.f Delete in its entirety.
- 11.01.A.5.g Delete in its entirety.
- 11.01.A.5.h Delete in its entirety.
- 11.03 Unit Price of Work:
- 11.03.D.1 Delete "materially and significantly", and insert "by more than plus or minus twenty percent (20%)".

## ARTICLE 12 – CHANGE OF CONTRACT PRICE; CHANGE OF CONTRACT TIMES

- 12.01 Change of Contract Price
- 12.01.A Add the following after the last sentence:  
Section 01025 shall be given precedence over section 00700 in regards to changes in contract price.
- 12.03 Delays
- 12.03.B Delete in its entirety and substitute the following:
- 12.03.B Delays beyond the control of the Contractor, as provided in paragraph 12.03.A, shall not entitle the Contractor to obtain additional project overhead costs unless such delays extend the Project as described below:
1. beyond the original Contract Times,
  2. beyond the Contract Times for which the overhead costs have been previously approved, or
  3. beyond Contract Times that are extended as a result of delays described in 12.03.C.

For the purpose of this paragraph, overhead costs shall be the supplemental costs defined in 11.01.A.5, paragraphs a, b, c, g, h and i. The Contractor's bid shall include all overhead costs as necessary to be on the Project for the original Contract Times.

12.03.C Add the following after the last sentence:

If the Contractor and the Owner cannot agree upon an equitable adjustment in the Contract Times, delays described in this Paragraph 12.03.C shall be determined as follows:

1. Contractor shall obtain weather history for the most recent five (5) years (minimum) preceding the Bid date. Weather history shall be obtained from the National Oceanic & Atmospheric Administration (NOAA) or other source approved by the Engineer. Historical weather shall be based on data from the weather reporting station closest to the project site.
2. For delays to be considered that are associated with an abnormal amount of rain, the Contractor shall use the weather history to calculate an average number of days that rainfall exceeded 0.1-inches for the period (month, quarter, year, etc.) in question. The average value calculated shall be rounded up to the next full day. A time extension may be considered equal to the number of days, above the calculated average, that the period in question experienced rainfall in excess of 0.1-inches. A Contract Time extension will not be considered for rain amounts less than 0.1-inches.
3. For daily rain amounts in excess of 1-inch, a time extension of one day beyond the number of days calculated as described above may be considered.
4. For delays associated with other abnormal weather events, the weather history shall be used to calculate an average number of days for the type of weather considered to be the cause of a delay. (Calculation of the average number of days shall be as described above.) Where the Contractor can demonstrate that the abnormal weather event has impaired his ability to perform work, beyond the day of the abnormal event, to perform site maintenance as necessary to restore the site to a workable condition may be considered.

**ARTICLE 13 – TESTS AND INSPECTIONS; CORRECTION, REMOVAL OR ACCEPTANCE OF DEFECTIVE WORK**

13.03 Tests and Inspections

13.03.B Delete in its entirety and substitute the following:

13.03.B Contractor shall employ and pay for inspections and testing services specifically noted as such in the Contract.

13.03.C Delete in its entirety and substitute the following:

13.03.C If the Contract Documents, laws, ordinances, rules, regulations or orders of any public authority having jurisdiction require any Work to be specifically inspected, tested, or approved by some public body, Contractor shall assume full responsibility therefore, pay all costs in connection therewith and furnish Engineer the required certificates of inspection, testing or approval.

Add the following:

13.03.G The OWNER reserves the right to independently perform at its own expense, laboratory tests on random samples of material or performance tests on equipment delivered to the site. These tests if made will be conducted in accordance with the appropriate referenced standards or Specification requirements. The entire shipment represented by a given

sample, samples or piece of equipment may be rejected on the basis of the failure of samples or pieces of equipment to meet specified test requirements. All rejected materials or equipment shall be removed from the site, whether stored or installed in the Work, and the required replacement shall be made, all at no additional cost to the OWNER.

13.05 OWNER May Stop the Work:

13.05A First sentence, after "...conform to the Contract Documents", insert "or if the Work interferes with the operation of the existing facility".

13.06 Correction or Removal of Defective Work

Add the following:

13.06.C At any time during the progress of the Work and up to the date of final acceptance, the Engineer shall have the right to reject any work which does not conform to the requirements of the Contract Documents, even though such work has been previously inspected and paid for. Any omissions or failure on the part of the Engineer to disapprove or reject any Work or materials at the time of inspection shall not be construed as an acceptance of any defective work or materials.

#### ARTICLE 14 – PAYMENTS TO CONTRACTOR AND COMPLETION

14.01 Schedule of Values

Add the following:

14.01.B The Contractor shall submit for the Engineer's approval, a complete breakdown of all Lump Sum Items in the Proposal. This breakdown, modified as directed by the Engineer, will be used as a basis for preparing estimates and establishing progress payments.

14.02 Progress Payments

14.02.A.3 Delete in its entirety and replace with the following:

14.02.A.3 Progress payment request shall include the percentage of the total amount of the Contract which has been completed from initiation of construction of the Project to and including the last day of the preceding month, or other mutually agreed upon day of the month accompanied by such data and supporting evidence as OWNER or Engineer may require.

Add the following:

14.02.A.4 Forms to be used shall be prepared by the Contractor and submitted to the Engineer for approval.

14.02.A.5 At the option of the OWNER, partial payment up to the estimated value, less retainage, may be allowed for any materials and equipment not incorporated in the Work, pursuant to the following conditions:

- a. Equipment or materials stored on the site shall be properly stored, protected and maintained.
- b. For any partial payment the Contractor shall submit, with his monthly progress payment from each material or equipment manufacturer, bills or invoices indicating actual material cost.
- c. Contractor shall submit evidence that he has paid for materials or equipment stored and for which the Engineer has authorized partial payment and previous progress

payments, prior to submission to the next monthly payment request. (See example letter at the end of this Section 00800).

- 14.02.A.6 The OWNER will retain ten percent (10%) of the amount of each such estimate until Work covered by the Contract is fifty percent (50%) complete. After fifty percent (50%) of the Work of the original Contract has been completed as evidenced by approved Partial Payment Requests exclusive of stored materials and in the opinion of the OWNER, satisfactory progress is being made, the OWNER may adjust future partial payment so that five percent (5%) of the original Contract Price is retained.
- 14.02.A.7 If the OWNER determines it is appropriate to reduce retainage, the method used for such adjustment shall be to fix retainage at five percent (5%) of the original Contract amount (when the work is 50% complete) and to pay all subsequent Partial Payment Requests to the full approved amount. The intent of such an adjustment is to gradually reduce retainage to five percent (5%) of the original Contract amount when the work is one hundred percent (100%) complete.
- 14.02.A.8 The OWNER may reinstate up to ten percent (10%) retainage if it is determined that the Contractor is not making satisfactory progress or there is other specific cause for retainage.
- 14.02.B.1 Review of Applications:  
First sentence, delete "10 days", insert "30 days".
- 14.02.C.1 Payment Becomes Due:  
First sentence, delete "Ten days" and insert "Thirty Days".
- 14.02.D.3 Delete in its entirety.
- 14.04 Substantial Completion
- 14.04 Delete paragraphs A, B, C, and D in their entirety and substitute the following:
- 14.04.A Contractor may, in writing to OWNER and Engineer, certify that the entire project is substantially complete and request that Engineer issue a certificate of Substantial Completion. Within a reasonable time thereafter, OWNER, Contractor and Engineer shall make an inspection of the Project to determine the status of completion. If Engineer and OWNER do not consider the Project substantially complete, Engineer will notify Contractor in writing giving his reasons therefore. If Engineer and OWNER consider the Project substantially complete, Engineer will prepare and deliver to OWNER a tentative certificate of Substantial Completion and the responsibilities between OWNER and Contractor for maintenance, heat and utilities. There shall be attached to the certificate a tentative list of items to be completed or corrected before Substantial Completion, and the certificate shall fix the time within which such items shall be completed or corrected, said time to be within Contract Time.
- 14.04.B In accordance with KRS 371.410, Substantial Completion is the point at which, as certified in writing by the contracting entity, a project is at the level of completion, in strict compliance with the contract, where:
1. Necessary approval by public regulatory authorities has been given;
  2. The Owner has received all required warranties and documentation; and
  3. The Owner may enjoy beneficial use or occupancy and may use, operate, and maintain the project in all respects, for its intended purpose.
- 14.05 Partial Utilization
- 14.05.A Delete in its entirety and substitute the following:



- 14.05.A Prior to Substantial Completion of the Project, OWNER may request Contractor in writing to permit him to use a specified part of the Project which he believes he may use without significant interference with construction of the other parts of the Project. If Contractor agrees, he will certify to OWNER and Engineer that said part of the Project is substantially complete and request the Engineer to issue a certificate of Substantial Completion for that part of the Project. Within a reasonable time thereafter, OWNER, Contractor and Engineer shall make an inspection of that part of the Project to determine its status of completion. If Engineer and OWNER do not consider that it is substantially complete, Engineer will notify Contractor in writing giving his reasons therefor. If Engineer and OWNER consider that part of the Project to be substantially complete, Engineer will execute and deliver to OWNER and Contractor a certificate to that effect, fixing the date of Substantial Completion as to that part of the Project, attaching thereto a tentative list of items to be completed or corrected before Substantial Completion of the entire Project and fixing the responsibility between OWNER and Contractor for maintenance, heat, and utilities as to that part of the Project. OWNER shall have the right to exclude Contractor from any part of the Project which Engineer has so certified to be substantially complete, but OWNER shall allow Contractor reasonable access to complete items on the tentative list.
- 14.05.B Equipment Warranty will not begin until after successful start-up, training, and acceptance by Owner for Partial Utilization. Any manufacturer's request to initiate warranty period earlier than Owner's acceptance will not be valid.

#### ARTICLE 15 – SUSPENSION OF WORK AND TERMINATION

##### 15.01 Owner May Suspend Work

Add the following:

15.01.B Should the OWNER suspend Work due to repeated unsafe Work conducted by the Contractor which is confirmed by subsequent inspection by OSHA, the Contractor shall not be allowed any adjustment in Contract Price or extension of Contract Time attributed to the delay.

##### 15.02 Owner May Terminate for Cause

15.02.A.2 Add the following to the end of first sentence after "jurisdiction":

"(including those governing employee safety)"

15.02D Delete in its entirety.

Add the following:

##### 15.05 Assignment of Contract

15.05 Contractor shall not assign, transfer, convey or otherwise dispose of the Contract, or of his legal right, title, or interest in or to the same or to any part thereof, without the prior written consent of the OWNER. Contractor shall not assign by power of attorney or otherwise any monies due him and payable under this Contract without the prior written consent of the OWNER. Such consent, if given, will in no way relieve the Contractor from any of the obligations of this Contract. OWNER shall not be bound to abide by or observe the requirements of any such assignment.

#### ARTICLE 16 – DISPUTE RESOLUTION

##### 16.01 Methods and Procedures

16.01.A Replace the first sentence with the following:

"If required by applicable laws and regulations, and not specifically excluded elsewhere, either OWNER or Contractor may request mediation of any Claim submitted to Engineer for a decision under Paragraph 10.05 before such decision becomes final and binding."

#### ARTICLE 17 – MISCELLANEOUS

17.01 Giving Notice

Add the following:

17.01.B No oral statement of any person whomsoever shall in any manner or degree modify or otherwise affect the terms of this Contract. Any notice to the Contractor, from OWNER and Engineer, relative to any part of this Contract shall be in writing.

Add the following:

17.07 Claims for Injury or Damage

17.07.A Should OWNER or Contractor suffer injury or damage to person or property because of any error, omission or act of the other party or of any of the other party's employees or agents or others for whose acts the other party is legally liable, claim will be made in writing to the other party within a reasonable time of the first observance of such injury or damage. The provisions of this paragraph 17.07 shall not be construed as a substitute for or a waiver of the provisions of any applicable statute of limitations or repose.

17.08 Non-Discrimination in Employment

17.08.A The Contractor shall comply with the following requirements prohibiting discrimination:

17.08.A.1 That no person (as defined in KRS 344.010) shall Bid on Lexington-Fayette Urban County Government Construction projects, or bid to furnish materials or supplies to the Lexington-Fayette Urban County Government, if, within six months prior to the time of opening of Bids, said person shall have been found, by declaratory judgment action in Fayette Circuit Court, to be presently engaging in an unlawful practice, as hereinafter defined. Such declaratory judgment action may be brought by an aggrieved individual or upon an allegation that an effort at conciliation pursuant to KRS 344.200 has been attempted and failed, by the Lexington-Fayette County Human Rights Commission.

17.08.A.2 That it is an unlawful practice for any employer:

- a. to fail or refuse to hire, or to discharge any individual or otherwise to discriminate against an individual, with respect to his compensation, terms, conditions, or privileges of employment, because of such individual's race, color, religion, sex, age, or national origin; or
- b. to limit, segregate or classify his employees in any way which would deprive or tend to deprive an individual of employment opportunities or otherwise adversely affect his status as an employee because of such individual's sex, race, color, religion, age, or national origin.

17.08.A.3 That it is unlawful practice for an employer, labor organization, or joint-labor management committee controlling apprenticeship or other training or retraining, including on-the-job training programs to discriminate against an individual because of his race, color, religion,

sex, age, or national origin in admission to, or employment in, any program established to provide apprenticeship or other training.

- 17.08.A.4 That a copy of the LFUCG Ordinance shall be available for viewing at the Lexington-Fayette Urban County Government offices.
- 17.09 Temporary Street Closing or Blockage
- 17.09.A The Contractor will notify the Engineer, Owner, and LFUCG Division of Traffic Engineering at least 72 hours prior to making any temporary street closing or blockage. This will permit orderly notification to all concerned public agencies.
- 17.10 Percentage of Work Performed by Prime Contractor
- 17.10.A The Contractor shall perform on site, and with its own organization, Work equivalent to at least fifty percent (50%) of the total amount of Work to be performed under the Contract. This percentage may be reduced by a supplemental agreement to this Contract if, during performing the Work, the Contractor requests a reduction and the Engineer determines that the reduction would be to the advantage of the OWNER.
- 17.11 Clean-Up
- 17.11.A Clean-up shall progress, to the greatest degree practicable, throughout the course of the Work. The Work will not be considered as completed, and final payment will not be made, until the right-of-way and all ground occupied or affected by the Contractor in connection with the Work has been cleared of all rubbish, equipment, excess materials, temporary structures, and weeds. Rubbish and all waste materials of whatever nature shall be disposed of, off of the project site, in an acceptable manner. All property, both public and private, which has been damaged in the prosecution of the Work, shall be restored in an acceptable manner. All areas shall be draining, and all drainage-ways shall be left unobstructed, and in such a condition that drift will not collect or scour be induced.
- 17.12 General
- 17.12.A The duties and obligations imposed by the Contract Documents and the rights and remedies available hereunder to the parties hereto, and, in particular but without limitation, the warranties, guarantees and obligations imposed upon Contractor, and all of the rights and remedies available to OWNER and Engineer, are in addition to, and are not to be construed in any way as a limitation of, any rights and remedies available to any or all of them which are otherwise imposed or available by Laws or Regulations, by special warranty or guarantee or by other provisions of the Contract Documents, and the provisions of this paragraph will be as effective as if repeated specifically in the Contract Documents in connection with each particular duty, obligation, right and remedy to which they apply. All representations, warranties and guarantees made in the Contract Documents will survive final payment and termination or completion of the Agreement.
- 17.13 Debris Disposal
- 17.13.A For all LFUCG projects any fill, trash, construction demolition debris, yard waste, dirt or debris of any kind that is removed from the project site must be disposed of in accordance with local, state, and federal regulations. The disposal site or facility must be approved in advance by the LFUCG and disposal documentation is required. The Contractor will be responsible for payment of any fines associated with improper disposal of material removed from the project site.
- 17.14 Maintenance of Traffic

- 17.14.A Traffic shall be maintained on state and LFUCG highways and streets at all times during construction. For all work that impacts traffic, the Contractor shall obtain a traffic permit at least two (2) working days in advance from the Division of Traffic Engineering (859) 258-3489.
- 17.14.B It shall be the Contractor's responsibility to notify LFUCG Police Department's Safety Officer (859) 258-3600 prior to performing any construction work, which might interfere with traffic or compromise the public safety.

Add the following:

**ARTICLE 18 – LIQUIDATED DAMAGES FOR FAILURE TO COMPLETE WORK ON TIME**

18.01 Liquidated Damages

- 18.01.A If the Contractor shall fail to complete the Work within the Contract Time, or extension of time granted by the OWNER in accordance with Article 12, then the Contractor will pay to the OWNER the amount for liquidated damages as specified in the Contract for each calendar day that the Contractor shall be in default after the time stipulated in the Contract Documents.

**\*\*\*PUT ON CONTRACTOR'S LETTERHEAD\*\*\***

DATE: \_\_\_\_\_

TO: OWNER: \_\_\_\_\_

ADDRESS: \_\_\_\_\_

\_\_\_\_\_

\_\_\_\_\_

RE: Project Title: \_\_\_\_\_  
Lexington Fayette Urban County Government  
Lexington, Kentucky  
LFUCG Bid No.: \_\_\_\_\_

We hereby certify that the labor and materials listed on this request for payment have been used in the construction of this work, or that all materials included in this request for payment and not yet incorporated into the construction are now on the site or stored at an approved location with proper insurance to protect these stored materials; and that all lawful charges for labor, materials etc., covered by previous Certificates of Payment have been paid and that all other lawful charges on which this request for payment is based have been paid for in full or will be paid for in full from the funds received in payment of this request within ten (10) calendar days from receipt of this partial payment from the OWNER.

CONTRACTOR: \_\_\_\_\_

BY: \_\_\_\_\_

TIME: \_\_\_\_\_

State of: \_\_\_\_\_

County of: \_\_\_\_\_

Sworn to and subscribed before me this \_\_\_\_\_ day of \_\_\_\_\_, 20\_\_\_\_.

\_\_\_\_\_  
Notary Public (Seal)

My Commission Expires: \_\_\_\_\_

END OF SECTION

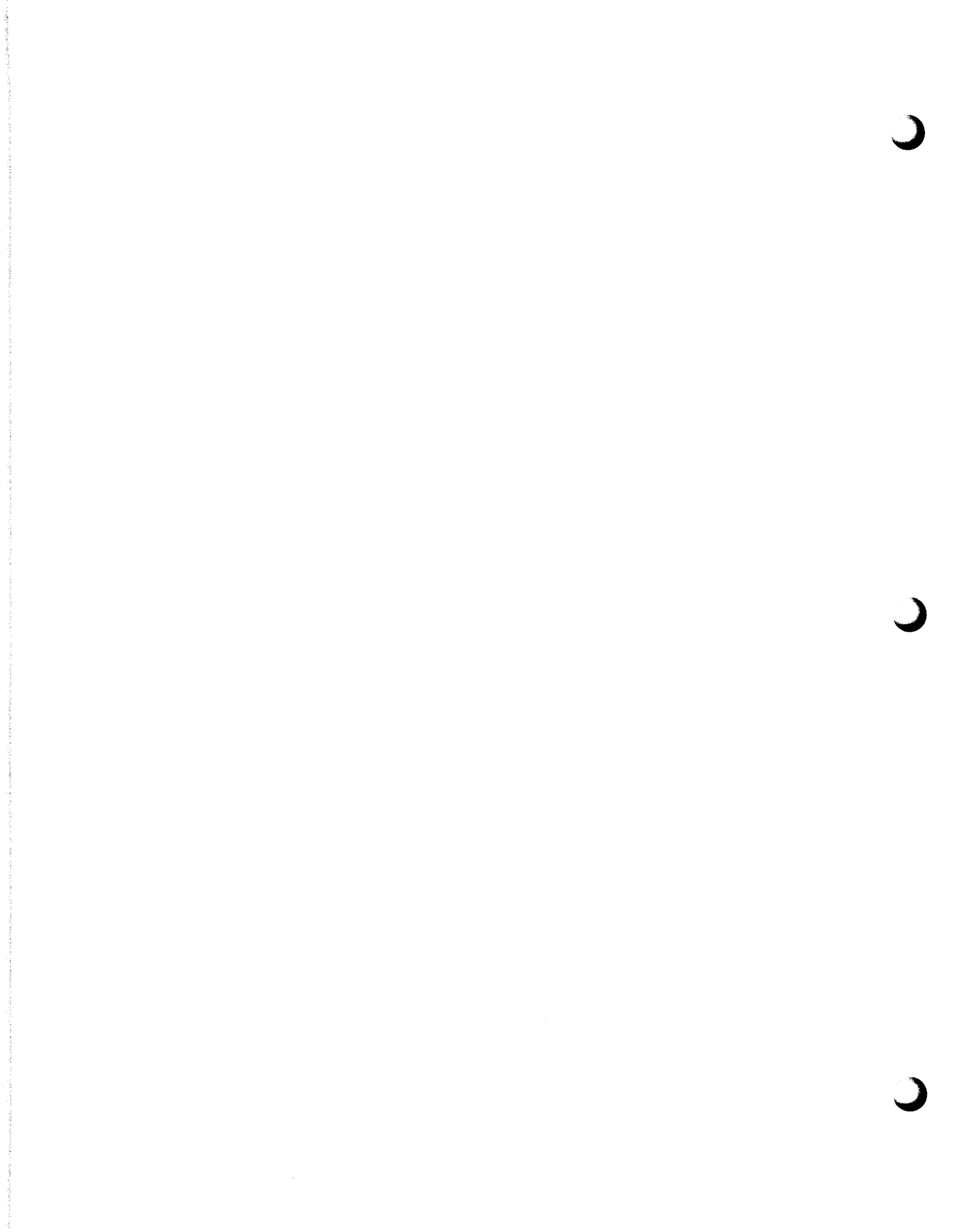

**SECTION 00810 – SUPPLEMENTAL GENERAL CONDITIONS FOR CLEAN WATER STATE  
REVOLVING FUND**

(This page intentionally left blank)

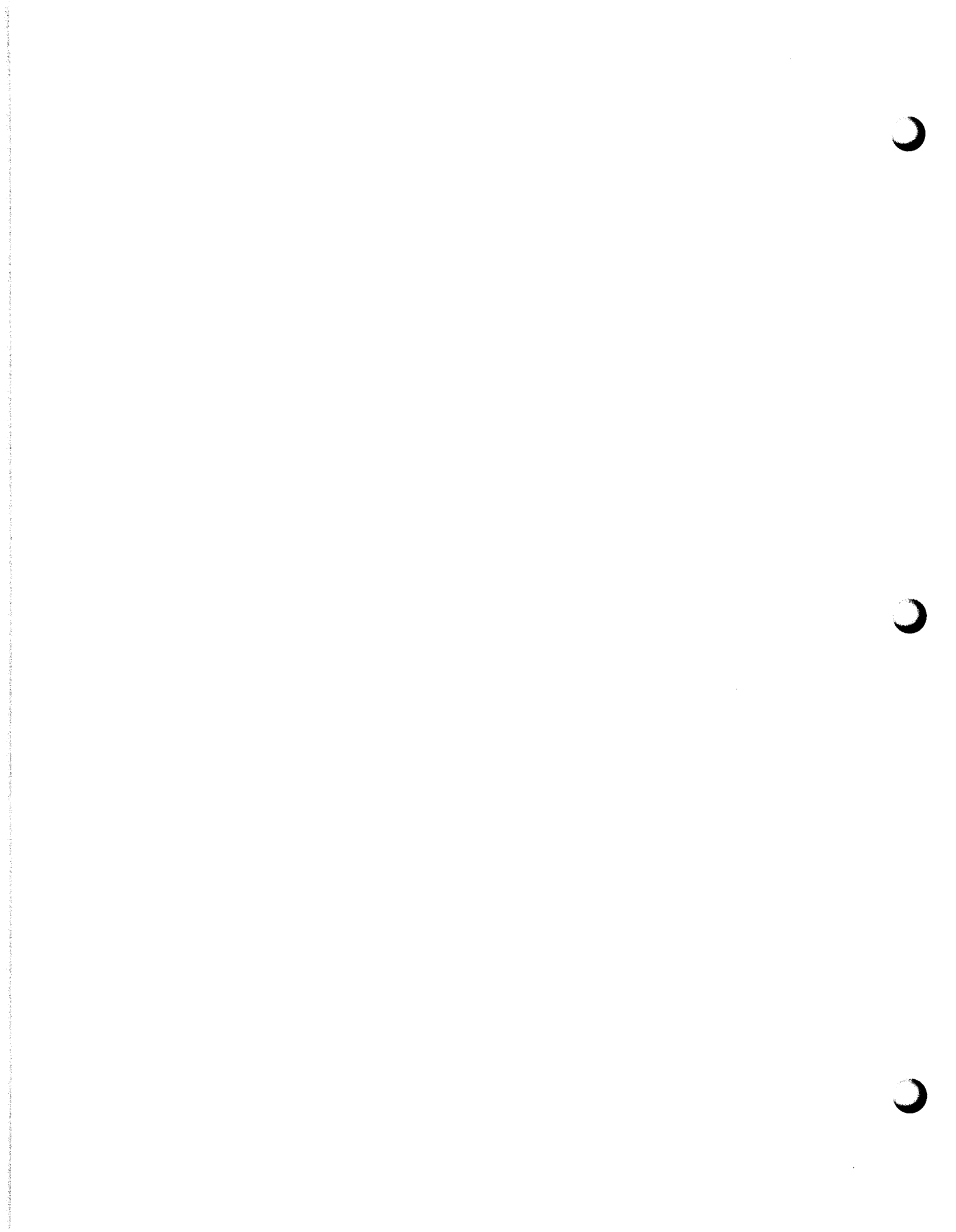



**SUPPLEMENTAL GENERAL CONDITIONS**  
**FOR**  
**CLEAN WATER STATE REVOLVING FUND**  
**DRINKING WATER STATE REVOLVING FUND**  
**(Drinking Water and Wastewater)**

The attached instructions and regulations as listed below shall be incorporated into the Specifications and comprise Special Conditions.

	<u>Attachment No.</u>
<b>SRF Special Provisions</b>	<b>1</b>
<b>KRS Chapter 45A-Kentucky Model Procurement Code</b>	<b>2</b>
<b>Equal Employment Opportunity (EEO) Documents:</b>	
<b>Notice of Requirement for Affirmative Action</b>	<b>3</b>
<b>Contract Specifications (Executive Order 11246)</b>	<b>4</b>
<b>EEO Goals for Region 4 Economic Areas</b>	<b>5</b>
<b>Special Notice #1 - Check List of EEO Documentation</b>	<b>6</b>
<b>Employer Information Report EEO-1 (SF 100)</b>	<b>7</b>
<b>Labor Standards Provisions for Federally Assisted Construction, EPA Form 5720-4</b>	<b>8</b>
<b>Certifications</b>	
<b>Debarment, Suspension and Other Responsibility Matters</b>	<b>9</b>
<b>Anti-lobbying</b>	<b>10</b>
<b>Region 4 Disadvantaged Business Enterprise (DBE)</b>	<b>11</b>
<b>Bonds and Insurance</b>	<b>12</b>
<b>Storm Water General Permit</b>	<b>13</b>
<b>Davis-Bacon Wage Rate Requirements under FY 2013 Continuing Resolution</b>	<b>14</b>
<b>American Iron and Steel Requirement</b>	<b>15</b>

**SRF SPECIAL PROVISIONS**

- (a) Line crossings of all roads and streets shall be done in accordance with the Kentucky Transportation Cabinet requirements as may be set forth in the Special Conditions.
- (b) Construction is to be carried out so as to prevent by-passing of flows during construction unless a schedule has been approved by the State or EPA, whichever is applicable. Siltation and soil erosion must be minimized during construction. All construction projects with surface disturbance of more than 1 acre during the period of construction must have a KPDES Storm Water General Permit. The permit can be found at the following web address: <https://dep.gateway.ky.gov/eForms/default.aspx?FormID=7>.  
  
If you have any questions regarding the completion of this form call the Surface Water Permits Branch at (502) 564-3410.
- (c) Restore disturbed areas to original or better condition.
- (d) **Use of Chemicals:** All chemicals used during project construction or furnished for project operation, whether herbicide, pesticide, disinfectant, polymer, reactant or of other classification, must show approval of either DOW or EPA. Use of all such chemicals and disposal of residues shall be in conformance with instructions on the manufacturer's label.
- (e) The construction of the project, including the letting of contracts in connection therewith, shall conform to the applicable requirements of state, territorial, and local laws and ordinances to the extent that such requirements do not conflict with Federal laws and this subchapter.
- (f) The owner shall provide and maintain competent and adequate supervision and inspection.
- (g) The Kentucky Infrastructure Authority and Kentucky Division of Water shall have access to the site and the project work at all times.
- (h) In the event Archaeological materials (arrowheads, stone tools, stone axes, prehistoric and historic pottery, bottles, foundations, Civil War artifacts, and other types of artifacts) are uncovered during the construction of this project, work is to immediately cease at the location and the Kentucky Heritage Council shall be contacted. The telephone number is (502) 564-7005. Construction shall commence at this location until a written release is received from the Kentucky Heritage Council. Failure to report a find could result in legal action.
- (i) This procurement will be subject to DOW Procurement Guidance including the Davis-Bacon Act.
- (j) Reasonable care shall be taken during construction to avoid damage to vegetation. Ornamental shrubbery and tree branches shall be temporarily tied back, where appropriate, to minimize damage. Trees which receive damage to branches shall be trimmed of those branches to improve the appearance of the tree. Tree trunks receiving damage from equipment shall be treated with a tree dressing.
- (k) No wastewater bypassing will occur during construction unless a schedule has been approved by the Kentucky Division of Water.
- (l) Change orders to the construction contract (if required) must be negotiated pursuant to DOW/KIA Procurement Guidance for Construction and Equipment Contracts.

**KRS Chapter 45A  
Kentucky Model Procurement Code**

**45A.075 Methods of awarding state contracts.**

Except as otherwise authorized by law, all state contracts shall be awarded by:

- (1) Competitive sealed bidding, pursuant to KRS 45A.080; or
- (2) Competitive negotiation, pursuant to KRS 45A.085 and 45A.090 or 45A.180; or
- (3) Noncompetitive negotiation, pursuant to KRS 45A.095; or
- (4) Small purchase procedures, pursuant to KRS 45A.100.

**Effective:** June 24, 2003

**History:** Amended 2003 Ky. Acts ch. 98, sec. 4, effective June 24, 2003. -- Created 1978 Ky. Acts ch. 110, sec. 16, effective January 1, 1979.

**45A.080 Competitive sealed bidding.**

(1) Contracts exceeding the amount provided by KRS 45A.100 shall be awarded by competitive sealed bidding, which may include the use of a reverse auction, unless it is determined in writing that this method is not practicable. Factors to be considered in determining whether competitive sealed bidding is not practicable shall include:

- (a) Whether specifications can be prepared that permit award on the basis of best value; and
- (b) The available sources, the time and place of performance, and other relevant circumstances as are appropriate for the use of competitive sealed bidding.

(2) The invitation for bids shall state that awards shall be made on the basis of best value. In any contract which is awarded under an invitation to bid which requires delivery by a specified date and imposes a penalty for late delivery, if the delivery is late, the contractor shall be given the opportunity to present evidence that the cause of the delay was beyond his control. If it is the opinion of the purchasing officer that there is sufficient justification for delayed delivery, the purchasing officer may adjust or waive any penalty that is provided for in the contract.

(3) Adequate public notice of the invitation for bids and any reverse auction shall be given a sufficient time prior to the date set forth for the opening of bids or beginning of the reverse auction. The notice may include posting on the Internet or publication in a newspaper or newspapers of general circulation in the state as determined by the secretary of the Finance and Administration Cabinet not less than seven (7) days before the date set for the opening of the bids and any reverse auction. The provisions of this subsection shall also apply to price contracts and purchase contracts of state institutions of higher education.

(4) Bids shall be opened publicly or entered through a reverse auction at the time and place designated in the invitation for bids. At the time the bids are opened, or the reverse auction has ended, the purchasing agency shall announce the agency's engineer's estimate, if applicable, and make it a part of the agency records pertaining to the letting of any contract for which bids were received. Each written or reverse auction bid, together with the name of the bidder and the agency's engineer's estimate, shall be recorded and be open to public inspection. Electronic bid opening and posting of the required information for public viewing shall satisfy the requirements of this subsection.

(5) The contract shall be awarded by written notice to the responsive and responsible bidder whose bid offers the best value.

(6) Correction or withdrawal of written or reverse auction bids shall be allowed only to the extent permitted by regulations issued by the secretary.

**Effective:** July 15, 2010

**History:** Amended 2010 Ky. Acts ch. 63, sec. 3, effective July 15, 2010. -- Amended 2000 Ky. Acts ch. 509, sec. 1, effective July 14, 2000. -- Amended 1998 Ky. Acts ch. 120, sec. 10, effective July 15, 1998. -- Amended 1997 (1st Extra. Sess.) Ky. Acts ch. 4, sec. 27, effective May 30, 1997. -- Amended 1996 Ky. Acts ch. 60, sec. 2, effective July 15, 1996. -- Amended 1994 Ky. Acts ch. 278, sec. 1, effective July 15, 1994. -- Amended 1982 Ky. Acts ch. 282, sec. 1, effective July 15, 1982. -- Amended 1979 (1st Extra. Sess.) Ky. Acts ch. 9, sec. 1, effective February 10, 1979. -- Created 1978 Ky. Acts ch. 110, sec. 17, effective January 1, 1979.

**45A.085 Competitive negotiation.**

(1) When, under administrative regulations promulgated by the secretary or under KRS 45A.180, the purchasing officer determines in writing that the use of competitive sealed bidding is not practicable, and except as provided in KRS 45A.095 and 45A.100, a contract may be awarded by competitive negotiation, which may include the use of a reverse auction.

(2) Adequate public notice of the request for proposals and any reverse auction shall be given in the same manner and circumstances as provided in KRS 45A.080(3).

(3) Contracts other than contracts for projects utilizing an alternative project delivery method under KRS 45A.180 may be competitively negotiated when it is determined in writing by the purchasing officer that the bids received by competitive sealed bidding either are unreasonable as to all or part of the requirements, or were not independently reached in open competition, and for which each competitive bidder has been notified of the intention to negotiate and is given reasonable opportunity to negotiate.

(4) Contracts for projects utilizing an alternative project delivery method shall be processed in accordance with KRS 45A.180.

(5) The request for proposals shall indicate the relative importance of price and other evaluation factors, and any reverse auction procedures.

(6) Award shall be made to the responsible and responsive offeror whose proposal is determined in writing to be the most advantageous to the Commonwealth, taking into consideration price and the evaluation factors set forth in the request for proposals and the reciprocal preference for resident bidders required under KRS 45A.494.

(7) Written or oral discussions shall be conducted with all responsible offerors who submit proposals determined in writing to be reasonably susceptible of being selected for award. Discussions shall not disclose any information derived from proposals submitted by competing offerors. Discussions need not be conducted:

(a) With respect to prices, where the prices are fixed by law, reverse auction, or administrative regulation, except that consideration shall be given to competitive terms and conditions;

(b) Where time of delivery or performance will not permit discussions; or

(c) Where it can be clearly demonstrated and documented from the existence of adequate competition or prior experience with the particular supply, service, or construction item, that acceptance of an initial offer without discussion would result in fair and reasonable best value procurement, and the request for proposals notifies all offerors of the possibility that award may be made on the basis of the initial offers.

**Effective:** July 15, 2010

**History:** Amended 2010 Ky. Acts ch. 63, sec. 4, effective July 15, 2010; and ch. 162, sec. 8, effective July 15, 2010. -- Amended 2003 Ky. Acts ch. 98, sec. 5, effective June 24, 2003. -- Amended 1997 (1st Extra. Sess.) Ky. Acts ch. 4, sec. 28, effective May 30, 1997. -- Amended 1979 (1st Extra. Sess.) Ky. Acts ch. 9, sec. 2, effective February 10, 1979. -- Created 1978 Ky. Acts ch. 110, sec. 18, effective January 1, 1979.

**45A.090 Negotiation after competitive sealed bidding when all bids exceed available funds.**

(1) In the event that all bids submitted pursuant to competitive sealed bidding under KRS 45A.080 result in bid prices in excess of the funds available for the purchase, and the chief purchasing officer determines in writing:

DOW – Feb 2016

(a) That there are no additional funds available from any source so as to permit an award to the responsive and responsible bidder whose bid offers the best value; and  
(b) The best interest of the state will not permit the delay attendant to a resolicitation under revised specifications, or for revised quantities, under competitive sealed bidding as provided in KRS 45A.080, then a negotiated award may be made as set forth in subsections (2) or (3) of this section.

(2) Where there is more than one (1) bidder, competitive negotiations pursuant to KRS 45A.085(3) shall be conducted with the three (3) (two (2) if there are only two (2)) bidders determined in writing to be the most responsive and responsible bidders, based on criteria contained in the bid invitation and the reciprocal preference for resident bidders under KRS 45A.494. Such competitive negotiations shall be conducted under the following restrictions:

(a) If discussions pertaining to the revision of the specifications or quantities are held with any potential offeror, all other potential offerors shall be afforded an opportunity to take part in such discussions; and

(b) A request for proposals, based upon revised specifications or quantities, shall be issued as promptly as possible, shall provide for an expeditious response to the revised requirements, and shall be awarded upon the basis of best value.

(3) Where, after competitive sealed bidding, it is determined in writing that there is only one (1) responsive and responsible bidder, a noncompetitive negotiated award may be made with such bidder in accordance with KRS 45A.095.

**Effective:** July 15, 2010

**History:** Amended 2010 Ky. Acts ch. 162, sec. 9, effective July 15, 2010. -- Amended 2003 Ky. Acts ch. 98, sec. 6, effective June 24, 2003. -- Amended 1997 (1st Extra. Sess.) Ky. Acts ch. 4, sec. 29, effective May 30, 1997. -- Created 1978 Ky. Acts ch. 110, sec. 19, effective January 1, 1979.

#### **45A.095 Noncompetitive negotiation.**

(1) A contract may be made by noncompetitive negotiation only for sole source purchases, or when competition is not feasible, as determined by the purchasing officer in writing prior to award, under administrative regulations promulgated by the secretary of the Finance and Administration Cabinet or the governing boards of universities operating under KRS Chapter 164A, or when emergency conditions exist. Sole source is a situation in which there is only one (1) known capable supplier of a commodity or service, occasioned by the unique nature of the requirement, the supplier, or market conditions. Insofar as it is practical, no less than three (3) suppliers shall be solicited to submit written or oral quotations whenever it is determined that competitive sealed bidding is not feasible. Award shall be made to the supplier offering the best value. The names of the suppliers submitting quotations and the date and amount of each quotation shall be placed in the procurement file and maintained as a public record. Competitive bids may not be required:

(a) For contractual services where no competition exists, such as telephone service, electrical energy, and other public utility services;

(b) Where rates are fixed by law or ordinance;

(c) For library books;

(d) For commercial items that are purchased for resale;

(e) For interests in real property;

(f) For visiting speakers, professors, expert witnesses, and performing artists;

(g) For personal service contracts executed pursuant to KRS 45A.690 to 45A.725; and

(h) For agricultural products in accordance with KRS 45A.645.

(2) The chief procurement officer, the head of a using agency, or a person authorized in writing as the designee of either officer may make or authorize others to make emergency procurements when an emergency condition exists.

(3) An emergency condition is a situation which creates a threat or impending threat to public health, welfare, or safety such as may arise by reason of fires, floods, tornadoes, other natural or man-caused disasters, epidemics, riots, enemy attack, sabotage, explosion, power failure, energy shortages, transportation emergencies, equipment failures, state or federal legislative mandates, or similar events. The existence of the emergency condition creates an immediate and serious need for services, construction, or items of tangible personal property that cannot be met through normal procurement methods and the lack of which would seriously threaten the functioning of government, the preservation or protection of property, or the health or safety of any person.

(4) The Finance and Administration Cabinet may negotiate directly for the purchase of contractual services, supplies, materials, or equipment in bona fide emergencies regardless of estimated costs. The existence of the emergency shall be fully explained, in writing, by the head of the agency for which the purchase is to be made. The explanation shall be approved by the secretary of the Finance and Administration Cabinet and shall include the name of the vendor receiving the contract along with any other price quotations and a written determination for selection of the vendor receiving the contract. This information shall be filed with the record of all such purchases and made available to the public. Where practical, standard specifications shall be followed in making emergency purchases. In any event, every effort should be made to effect a competitively established price for purchases made by the state.

**Effective:** July 15, 2002

**History:** Amended 2002 Ky. Acts ch. 344, sec. 9, effective July 15, 2002. -- Amended 1997 (1st Extra. Sess.) Ky. Acts ch. 4, sec. 30, effective May 30, 1997. -- Amended 1990 Ky. Acts ch. 496, sec. 4, effective July 13, 1990. -- Created 1978 Ky. Acts ch. 110, sec. 20, effective January 1, 1979

#### **45A.100 Small purchases by state governmental bodies.**

(1) Procurements may be made in accordance with small purchase administrative regulations promulgated by the secretary of the Finance and Administration Cabinet, pursuant to KRS Chapter 13A, as follows:

(a) Up to ten thousand dollars (\$10,000) per project for construction and one thousand dollars (\$1,000) for purchases by any state governmental body, except for those state administrative bodies specified in paragraph (b) of this subsection; and

(b) Up to forty thousand dollars (\$40,000) per project for construction or purchases by the Finance and Administration Cabinet, state institutions of higher education, and the legislative branch of government.

(2) Procurement requirements shall not be artificially divided so as to constitute a small purchase under this section. Reverse auctions may be used for small purchase procurements. At least every two (2) years, the secretary shall review the prevailing costs of labor and materials and may make recommendations to the next regular session of the General Assembly for the revision of the then current maximum small purchase amount as justified by intervening changes in the cost of labor and materials.

(3) The secretary of the Finance and Administration Cabinet may grant to any state agency with a justifiable need a delegation of small purchasing authority which exceeds the agency's small purchase limit provided in subsection (1) of this section. Delegations of small purchasing authority shall be granted or revoked by the secretary of the Finance and Administration Cabinet, in accordance with administrative regulations promulgated by the cabinet pursuant to KRS Chapter 13A. These administrative regulations shall establish, at a minimum, the criteria for granting and revoking delegations of small purchasing authority, including the requesting

agency's past compliance with purchasing regulations, the level of training of the agency's purchasing staff, and the extent to which the agency utilizes the Kentucky Automated Purchasing System. The administrative regulations may permit the secretary of the Finance and Administration Cabinet to delegate small purchase procurements up to the maximum amount specified in subsection (1)(b) of this section.

**Effective:** July 15, 2010

**History:** Amended 2010 Ky. Acts ch. 63, sec. 5, effective July 15, 2010. -- Amended 2002 Ky. Acts ch. 320, sec. 2, effective July 15, 2002. -- Amended 2000 Ky. Acts ch. 225, sec. 1, effective July 14, 2000. -- Amended 1996 Ky. Acts ch. 60, sec. 1, effective July 15, 1996. -- Amended 1994 Ky. Acts ch. 323, sec. 1, effective July 15, 1994. -- Amended 1990 Ky. Acts ch. 496, sec. 5, effective July 13, 1990. -- Amended 1986 Ky. Acts ch. 384, sec. 1, effective July 15, 1986. -- Amended 1984 Ky. Acts ch. 384, sec. 1, effective July 13, 1984. -- Amended 1982 Ky. Acts ch. 282, sec. 2, effective July 15, 1982. -- Amended 1980 Ky. Acts ch. 242, sec. 1, effective July 15, 1980; and ch. 250, sec. 19, effective April 9, 1980. -- Created 1978 Ky. Acts ch. 110, sec. 21, effective January 1, 1979.



**NOTICE OF REQUIREMENT FOR AFFIRMATIVE ACTION TO ENSURE  
EQUAL EMPLOYMENT OPPORTUNITY (EXECUTIVE ORDER 11246)**

The following excerpts are from 45 FR 65984 (October 3, 1980):

The minority and female goals apply to Federal and federally assisted construction contractors and subcontractors which have covered contracts. The goals are expressed as a percentage of the total hours worked by such a covered or subcontractor's entire onsite construction workforce, which is working on any construction site within a relevant area. The goal applies to each construction craft and trade in the contractor's entire workforce in the relevant area including those employees working on private non-federally involved projects.

Until further notice, the following goals for minority utilization in each construction craft and trade shall be included in all Federal or federally assisted construction contracts and subcontracts in excess of \$10,000 to be performed in the respective geographic area. The goals are applicable to each nonexempt contractor's total onsite construction workforce, regardless of whether or not part of that workforce is performing work on a Federal, federally assisted or non-federally related project, contract or subcontract.

Construction contractors which are participating in an approved Hometown Plan (see 41 CFR 60-4.5) are required to comply with the goals of the Hometown Plan with regard to construction work they perform in the area covered by the Hometown Plan. With regard to all their other covered construction work, such contractors are required to comply as follows:

- Goals for female participation in each trade.....6.9%
- Goals for minority participation in each trade.....Insert goals for each year  
(see Attachment Number 5)

These goals are applicable to all the Contractor's construction work (whether or not it is Federal or Federally assisted) performed in the covered area.

The following excerpts are from 45 FR 65977 (October 3, 1980):

The Contractor's compliance with the Executive Order and the regulations in 41 CFR Part 60-4 shall be based on its implementation of the Equal Opportunity Clause, specific affirmative action obligations required by the specifications set forth in 41 CFR 60-4.3(a), and its efforts to meet the goals established for the geographical area where the contract resulting from this solicitation is to be performed. The hours of minority and female employment and training must be substantially uniform throughout the length of the contract, and in each trade, and the contractor shall make a good faith effort to employ minorities and women evenly on each of its projects. The transfer of minority or female employees or trainees from Contractor to Contractor or from project to project for the sole purpose of meeting the Contractor's goals shall be a violation of the contract, the Executive Order and the regulations in 41 CFR Part 60-4. Compliance with the goals will be measured against the total work hours performed.

3. The Contractor shall provide written notification to the Director of the Office of Federal Contract Compliance Programs within 10 working days of award of any construction subcontract in excess of \$10,000 at any tier for construction work under the contract resulting from this solicitation. The notification shall list the name, address and telephone number of the subcontractor; employer identification number; estimated dollar amount of the subcontract; estimated starting and completion dates of the subcontract; and the geographical area in which the contract is to be performed.

4. As used in this Notice, and in the contract resulting from this solicitation, the covered area is (insert description of the geographical areas where the contract is to be performed giving the state, country, and city, if any).

**STANDARD FEDERAL EQUAL EMPLOYMENT OPPORTUNITY CONSTRUCTION  
CONTRACT SPECIFICATIONS (EXECUTIVE ORDER 11246)**

EEO Specifications

Following is the standard language, which must be incorporated into all solicitations for offers and bids on all Federal and Federally assisted construction contracts or subcontracts in excess of \$10,000 to be performed in designated geographical areas:

1. As used in these specifications:
  - (a) Covered Area means the geographical area described in the solicitation from which this contract resulted.
  - (b) Director means Director, Office of Federal Contract Compliance Program, United States Department of Labor, or any person to whom the Director delegates authority;
  - (c) Employer identification number means the Federal Social Security number used on the Employer's Quarterly Federal Tax Return, U.S. Treasury Department Form 941.
  - (d) Minority includes:
    - (i) Black (all persons having origins in any of the Black African racial groups not of Hispanic origin);
    - (ii) Hispanic (all persons of Mexican, Puerto Rican, Cuban, Central or South American or other Spanish Culture or origin, regardless of race);
    - (iii) Asian and Pacific Islander (all persons having origins in any of the original peoples of the Far East, Southeast Asia, the Indian Subcontinent, or the Pacific Islands); and
    - (iv) American Indian or Alaskan Native (all persons having origins in any of the original peoples of North America and maintaining identifiable tribal affiliations through membership and participation or community identification).
2. Whenever the Contractor or any Subcontractor at any tier, subcontracts a portion of the work involving any construction trade, it shall physically include in each subcontract in excess of \$10,000 the provisions of these specifications and the Notice which contains the applicable goals for minority and female participation and which is set forth in the solicitations from which this contract resulted.
3. If the Contractor is participating (pursuant to 41 CFR 60-4.5) in a Hometown Plan approved by the U.S. Department of Labor in the covered area either individually or through an association, its affirmative action obligations on all work in the Plan area (including goals and timetables) shall be in accordance with that Plan for those trades which have unions participating in the Plan. Contractors must be able to demonstrate their participation in and compliance with the provisions of any such Hometown Plan. Each Contractor or Subcontractor participating in an approved Plan is individually required to comply with its obligations under the EEO clause, and to make a good faith effort to achieve each goal under the Plan in each trade in which it has employees. The overall good faith performance by other Contractors or Subcontractors toward a goal in an approved Plan does not excuse any covered Contractor's or Subcontractor's failure to take a good faith efforts to achieve the Plan goals and timetables.
4. The Contractor shall implement the specific affirmative action standards provided in paragraphs 7-a through p of these specifications. The goals set forth in the solicitation from which this contract resulted are expressed as percentages of the total hours of employment and training of minority and female utilization the Contractor should reasonably be able to achieve in each construction trade in which it has

employees in the covered area. The Contractor is expected to make substantially uniform progress toward its goals in each craft during the period specified.

5. Neither the provisions of any collective bargaining agreement, nor the failure by a union with whom the Contractor has a collective bargaining agreement, to refer either minorities or women shall excuse the Contractor's obligations under these specifications, Executive Order 11246, or the regulations promulgated pursuant thereto.

6. In order for the non-working training hours of apprentices and trainees to be counted in meeting the goals, such apprentices and trainees must be employed by the contractor during the training period, and the Contractor must have made a commitment to employ the apprentices and trainees at the completion of their training, subject to the availability of employment opportunities. Trainees must be trained pursuant to training programs approved by the U.S. Department of Labor.

7. The Contractor shall take specific affirmative action to ensure equal employment opportunity. The evaluation of the Contractor's compliance with these specifications shall be based upon its effort to achieve maximum results from its actions. The Contractor shall document these efforts fully, and shall implement affirmative actions steps at least as extensively as the following:

a. Ensure and maintain a working environment free of harassment, intimidation, and coercion at all sites, and in all facilities at which the contractor's employees are assigned to work. The Contractor, where possible, will assign two or more women to each construction project. The Contractor shall specifically ensure that all foremen, superintendents, and other on-site supervisory personnel are aware of and carry out the Contractor's obligation to maintain such a working environment, with specific attention to minority or female individuals working at such sites or in such facilities.

b. Establish and maintain a current list of minority and female recruitment sources, provide written notification to minority and female recruitment sources and to community organizations when the contractor or its unions have employment opportunities available, and maintain a record of the organizations responses.

c. Maintain a current file of the names, addresses and telephone numbers of each minority and female off-the-street applicant and minority or female referral from a union, a recruitment source or community organization and of what action was taken with respect to each such individual. If such individual was sent to the union hiring hall for referral and was not referred back to the Contractor by the union or, if referred, not employed by the contractor, this shall be documented in the file with the reason therefore, along with whatever additional actions the contractor may have taken.

d. Provide immediate written notification to the Director when the union or unions with which the Contractor has a collective bargaining agreement has not referred to the Contractor a minority person or woman sent by the Contractor, or when the Contractor has other information that the union referral process has impeded the Contractor's efforts to meet its obligation.

e. Develop on-the-job training opportunities and/or participate in training programs for the area which expressly include minorities and women, including upgrading programs and apprenticeship and trainee programs relevant to the Contractor's employment needs, especially those programs funded or approved by the Department of Labor. The Contractor shall provide notice of these programs to the sources complied under 7-b above.

f. Disseminate the Contractor's EEO policy by providing notice of the policy to unions and training programs and requesting their cooperation in assisting the Contractor in meeting its EEO obligations; by including it in any policy manual and collective bargaining agreement; by publicizing it in the company newspaper, annual report, etc.; by specific review of the policy with all management personnel and with all minority and female employees at least once a year; and

by posting the company EEO policy on bulletin boards accessible to all employees at each location where construction work is performed.

g. Review, at least annually, the company's EEO policy and affirmative action obligations under these specifications with all employees having any responsibility for hiring, assignment, lay-off, termination or other employment decisions including specific review of these items with on-site supervisory personnel such as Superintendents, General Foreman, etc., prior to the initiation of construction work at any job site. A written record shall be made and maintained identifying the time and place of these meetings, persons attending, subject matter discussed, and disposition of the subject matter.

h. Disseminate the Contractor's EEO policy externally by including it in any advertising in the news media, specifically including minority and female news media, and providing written notification to and discussing the Contractor's EEO policy with other Contractors and Subcontractors with whom the Contractor does or anticipates doing business.

i. Direct its recruitment efforts, both oral and written, to minority, female and community organizations, to schools with minority and female students and to minority and female recruitment and training organizations serving the Contractor's recruitment area and employment needs. Not later than one month prior to the date for the acceptance of applications for apprenticeship or other training by any recruitment source, the contractor shall send written notification to organizations such as the above, describing the openings, screening procedures, and tests to be used in the selection process.

j. Encourage present minority and female employees to recruit other minority persons and women and, where reasonable, provide after school, summer and vacation employment to minority and female youth both on the site and in other areas of a Contractor's workforce.

k. Validate all tests and other selection requirements where there is an obligation to do so under 41 CFR Part 60-3.

l. Conduct, at least annually, an inventory and evaluation of all minority and female personnel for promotional opportunities and encourage these employees to seek or to prepare for, through appropriate training, etc., such opportunities.

m. Ensure that seniority practices, job classifications, work assignments and other personnel practices, do not have a discriminatory effect by continually monitoring all personnel and employment related activities to ensure that EEO policy and the Contractor's obligations under these specifications are being carried out.

n. Ensure that all facilities and company activities are nonsegregated except that separate or single-user toilet and necessary changing facilities shall be provided to assure privacy between the sexes.

o. Document and maintain a record of all solicitations of offers for subcontracts from minority and female construction contractors and suppliers, including circulation of solicitations to minority and female contractor associations and other business associations.

p. Conduct a review, at least annually, of all supervisor's adherence to and performance under the Contractor's EEO policies and affirmative action obligations.

8. Contractors are encouraged to participate in voluntary associations, which assist in fulfilling one or more of their affirmative actions obligations (7 a through p). The efforts of a contractor association, joint contractor-union, contractor-community, of other similar group of which the contractor is a member and participant may be asserted as fulfilling any one or more of its obligations under 7 a through p of these specifications provided that the contractor actively participates in the group, makes every effort to assure

that the group has a positive impact on the employment of minorities and women in the industry, ensures that the concrete benefits of the program are reflected in the Contractor's minority and female workforce participation, makes a good faith effort to meet its individual goals and timetables, and can provide access to documentation which demonstrates the effectiveness of actions taken on behalf of the Contractor. The obligation to comply, however, is the Contractor's and failure of such a group to fulfill an obligation shall not be defense for the Contractor's noncompliance.

9. A single goal for minorities and a separate single goal for women have been established. The contractor, however, is required to provide equal employment opportunity and to take affirmative action for all minority groups, both male and female, and all women, both minority and non-minority. Consequently, the Contractor may be in violation of the Executive Order if a particular group is employed in a substantially disparate manner (for example: even though the Contractor has achieved its goal for women generally, the Contractor may be in violation of the Executive Order if a specific minority group of women is underutilized).

10. The Contractor shall not use the goals and timetables for affirmative action standards to discriminate against any person because of race, color, religion, sex or national origin.

11. The Contractor shall not enter into any Subcontract with any person or firm debarred from Government contracts pursuant to Executive Order 11246.

12. The Contractor shall carry out such sanctions and penalties for violation of these specifications and of the Equal Opportunity Clause, including suspension, termination and cancellation of existing subcontracts as may be imposed or ordered pursuant to Executive Order 11246, as amended, and its implementing regulations, by the Office of Federal Contract Compliance Programs. Any Contractor who fails to carry out such sanctions and penalties shall be in violation of these specifications and executive Order 11246, as amended.

13. The Contractor, in fulfilling its obligations under these specifications, shall implement specific affirmative action steps, at least as extensive as those standards prescribed in paragraph 7 of these specifications, so as to achieve maximum results from its efforts to ensure equal employment opportunity. If the Contractor fails to comply with the requirements of the Executive Order, the implementing regulations, or these specifications, the Director shall proceed in accordance with 41 CFR 60-4.8.

14. The Contractor shall designate a responsible official to monitor all employment related activity to ensure that the company EEO policy is being carried out, to submit reports relating to the provisions hereof as may be required by the Government and to keep records. Records shall at least include for each employee the name, address, telephone numbers, construction trade, union affiliation, if any, employee identification number when assigned, social security number, race, sex, status (e.g., mechanic, apprentice, trainee, helper or laborer), dates of changes in status, hours worked per week in the indicated trade, rate of pay, and locations at which the work was performed. Records shall be maintained in an easily understandable and retrievable form; however, to the degree that existing records satisfy this requirement, contractors shall not be required to maintain separate records.

15. Nothing herein provided shall be construed as a limitation upon the application of other laws which establish different standards of compliance or upon the application of requirements for the hiring of local or other area residents (e.g., those under the Public Works Employment Act of 1977 and the Community Development Block Grant Program).

**EEO Goals for Economic Areas in Region 4**

Source: Appendix B-80 in 45 FR 65984 (October 3, 1980)

**Kentucky:**

053 Knoxville, TN

SMSA Counties:

3840 Knoxville, TN .....6.6

TN Anderson; TN Blount; TN Knox; TN Union.

Non-SMSA Counties .....4.5

KY Bell; KY Harlan; KY Knox; KY Laurel; KY McCreary; KY Wayne; KY Whitley; TN Campbell; TN Claiborne; TN Cocke; TN Cumberland; TN Fentress; TN Grainger, TN Hamblen; TN Jefferson; TN Loudon; TN Morgan; TN Roane; TN Scott; TN Sevier.

054 Nashville, TN:

SMSA Counties:

1660 Clarksville - Hopkinsville, TN - KY .....18.2

KY Christian; TN Montgomery.

5360 Nashville - Davidson, TN .....15.8

TN Cheatham, TN Davidson; TN Dickson; TN Robertson; TN Rutherford; TN Sumner; TN Williamson; TN Wilson.

Non-SMSA Counties .....12.0

KY Allen; KY Barren; KY Butler; KY Clinton; KY Cumberland; KY Edmonson; KY Logan; KY Metcalfe; KY Monroe; KY Simpson; KY Todd; KY Trigg; KY Warren; TN Bedford; TN Cannon; TN Clay; TN Coffee; TN DeKalb; TN Franklin; TN Giles; TN Hickman; TN Houston; TN Humphreys; TN Jackson; TN Lawrence; TN Lewis; TN Macon; TN Marshall; TN Maury; TN Moore; TN Overton; TN Perry; TN Pickett; TN Putnam; TN Smith; TN Stewart; TN Trousdale; TN Van Buren; TN Warren; TN Wayne; TN White.

056 Paducah, KY:

Non-SMSA Counties .....5.2

IL Hardin; IL Massac; IL Pope; KY Ballard; KY Caldwell; KY Calloway. KY Carlisle; KY Crittenden; KY Fulton; KY Graves; KY Hickman; KY Livingston; KY Lyon. KY McCracken; KY Marshall.

057 Louisville, KY:

SMSA Counties:

4520 Louisville, KY-IN .....11.2

IN Clark; IN Floyd; KY Bullitt; KY Jefferson; KY Oldham.

Non-SMSA Counties .....9.6

IN Crawford; IN Harrison; IN Jefferson; IN Orange; IN Scott; IN Washington; KY Breckinridge; KY Grayson; KY Hardin; KY Hart; KY Henry; KY Larue; KY Marion; KY Meade; KY Nelson; KY Shelby; KY Spencer; KY Trimble; KY Washington.

058 Lexington, KY

SMSA Counties

4280 Lexington-Fayette, KY .....10.8

KY Bourbon; KY Clark; KY Fayette; KY Jessamine; KY Scott; KY Woodford.

Non-SMSA Counties .....7.0

KY Adair KY Anderson; KY Bath; KY Boyle; KY Breathitt; KY Casey; KY Clay; KY Estill; KY Franklin; KY Garrard; KY Green; KY Harrison; KY Jackson; KY Knott; KY Lee; KY Leslie; KY Letcher; KY Lincoln; KY Madison; KY Magoffin; KY Menifee; KY Mercer; KY Montgomery; KY Morgan. KY Nicholas; KY Owsley; KY Perry; KY Powell; KY Pulaski; KY Rockcastle; KY Russell; KY Taylor; KY Wolfe.

059 Huntington, WV:

SMSA Counties:

3400 Huntington - Ashland, WV-KY-OH .....2.9

KY Boyd; KY Greenup; OH Lawrence; WV Cabell; WV Wayne.

Non-SMSA Counties .....2.5

KY Carter; KY Elliott; KY Floyd; KY Johnson; KY Lawrence; KY Martin; KY Pike; KY Rowan; OH Gallia; WV Lincoln; WV Logan; WV Mason; WV Mingo.

067 Cincinnati, OH:

SMSA Counties:

1640 Cincinnati, OH-KY-IN .....11.0

IN Dearborn; KY Boone; KY Campbell; KY Kenton; OH Clermont; OH Hamilton; OH Warren.

3200 Hamilton-Middletown, OH .....	5.0
OH Butler.	
Non-SMSA Counties .....	9.2
IN Franklin; IN Ohio; IN Ripley; IN Switzerland; KY Bracken; KY Carroll; KY Fleming; KY Gallatin; KY Grant; KY Lewis; KY Mason; KY Owen; KY Pendleton; KY Robertson; OH Adams; OH Brown; OH Clinton; OH Highland.	
080 Evansville, IN:	
SMSA Counties	
2440 Evansville, IN-KY .....	4.8
IN Gibson; IN Posey; IN Vanderburgh; IN Warrick; KY Henderson.	
5990 Owensboro, KY .....	4.7
KY Daviess.	
Non-SMSA Counties .....	3.5
IL Edwards; IL Gallatin; IL Hamilton; IL Lawrence; IL Saline; IL Wabash; IL White; IN Dubois; IN Knox; IN Perry; IN Pike; IN Spencer; KY Hancock; KY Hopkins; KY McLean; KY Muhlenberg; KY Ohio; KY Union; KY Webster.	

**CHECK LIST OF EEO DOCUMENTATION FOR BIDDERS  
ON GRANT/LOAN CONSTRUCTION  
(Required by Executive Order 11246 as amended)**

The low, responsive responsible bidder must forward the following items, in duplicate, to the owner no later than ten (10) days after bid opening. The owner shall have one (1) copy available for inspection by the Office of Federal Contracts Compliance within 14 days after the bid opening. The web site for the OFCC is [http://www.dol.gov/ofccp/regs/compliance/ca\\_11246.htm](http://www.dol.gov/ofccp/regs/compliance/ca_11246.htm).

1. Project Number. Project Location. Type of Construction.
2. Proof of registration with the Joint Reporting Commission. (See Attachment Number 7.)
3. Copy of Affirmative Action Plan of contractor. Indicate company official responsible for EEO.
4. List of current construction contracts, with dollar amount. List contracting Federal Agency, if applicable.
5. Statistics concerning company percent workforce, permanent and temporary, by sex, race, trade, handicapped, and age. 40 CFR Part 7.
6. List of employment sources for project in question. If union sources are utilized, indicate percentage of minority membership within the union crafts.
7. Anticipated employment needs for this project, by sex, race and trade, with estimate of minority participation in specific trades.
8. List of subcontractors (name, address and telephone) with dollar amount and duration of subcontract. Subcontractor contracts over \$10,000 must submit items 1- 8. The following information must be provided for all supplier contracts regardless of contract size: name of company, contact person, address, telephone number, dollar value of the contract, and a list of the materials to be supplied to the prime contractor.
9. List of any subcontract work yet to be committed with estimate of dollar amount and duration of contract.
10. Contract Price. Duration of prime contract.
11. DBE Documents - See special instructions regarding use of Minority, and Women Owned, and Small Businesses.



## Employer Information Report EEO-1

Under the direction of the US Equal Employment Opportunity Commission, the Joint Reporting Committee is responsible for the full-length, multi-phase processing of employment statistics collected on the Employer Information Report EEO-1. This report, also termed Standard Form 100, details the sex and race/ethnic composition of an employer's work force by job category.

The Employer Information EEO-1 survey is conducted annually under the authority of Public Law 88-352, Title VII of the Civil Rights Act of 1964, as amended by the Equal Employment Opportunity Act of 1972. All employers with 15 or more employees are covered by Public Law 88-352 and are required to keep employment records as specified by Commission regulations. Based on the number of employees and federal contract activities, certain large employers are required to file an EEO-1 Report on an annual basis.

The EEO-1 Report must be filed by:

(A) All private employers who are: (1) subject to Title VII of the Civil Rights Act of 1964 (as amended by the Equal Employment Opportunity Act of 1972) with 100 or more employees EXCLUDING State and local governments, primary and secondary school systems, institutions of higher education, Indian tribes and tax-exempt private memberships clubs other than labor organizations; OR (2) subject to Title VII who have fewer than 100 employees if the company is owned or affiliated with another company, or there is centralized ownership, control or management (such as central control of personnel policies and labor relations) so that the group legally constitutes a single enterprise and the entire enterprise employs a total of 100 or more employees.

(B) All federal contractors (private employers), who: (1) are not exempt as provided for by 41 CFR 60-1.5, (2) have 50 or more employees, and (a) are prime contractors or first-tier subcontractors, and have a contract, subcontract, or purchase order amounting to \$50,000 or more; or (b) serve as depository of Government funds in any amount, or (c) is a financial institution which is an issuing an paying agent for U.S. Savings Bonds and Notes.

Only those establishments located in the District of Columbia and the 50 states are required to submit the EEO-1 Report. No Reports should be filed for establishments in Puerto Rico, the Virgin Islands or other American Protectorates.

When filing for the EEO-1 Report for the first time, go to the web site at:

<http://www.eeoc.gov/employers/eo1survey/>

and select "Filing Time Filers" from the box labeled INFORMATION. File out the electronic questionnaire to enter your company into Joint Reporting Committee (JRC) system. Once you have completed the registration process, you will be contacted on how to proceed with the EEO-1 Report. If you have previously registered with the JRC, follow their instructions to update your information.

### Labor Standards Provisions for Federally Assisted Construction

Labor standards provisions applicable to contracts covering federally financed and assisted construction (29 CFR 5.5, Contract Provisions and Related Matters) that apply to EPA Special Appropriations Projects grants are:

- (a)(4)(iii) Equal employment opportunity. The utilization of apprentices, trainees and journeymen under this part shall be in conformity with the equal employment opportunity requirements of Executive Order 11246, as amended, and 29 CFR Part 30.
- (a)(5) Compliance with Copeland Act requirements. The contractor shall comply with the requirements of 29 CFR Part 3, which are incorporated by reference in this contract.
- (a)(6) Subcontracts. The contractor or subcontractor shall insert in any subcontracts the clauses contained in 29 CFR 5.5 (a) (1) through (10) and such other clauses as the U.S. Environmental Protection Agency may by appropriate instructions require, and also a clause requiring the subcontractors to include these clauses in any lower tier subcontracts. The prime contractor shall be responsible for the compliance by any subcontractor or lower tier subcontractor with all the contract clauses in 29 CFR 5.5.
- (a)(7) Contract termination: debarment. A breach of the contract clauses in 29 CFR 5.5 may be grounds for termination of the contract, and debarment as a contractor and a subcontractor as provided in 29 CFR 5.12.
- (b) Contractor Work Hours and Safety Standards Act. The Administrator, EPA shall cause or require the contracting officer to insert the following clauses set forth in paragraph (b)(1),(2),(3), and (4) of this section in full in any contract subject to the overtime provisions of the Contract Work Hours and Safety Standards Act. These clauses shall be inserted in addition to the clauses required by \*Section 5.5(a) of this title. As used in this paragraph, the terms laborers and mechanics include watchmen and guards.
- (1) Overtime requirements. No contractor or subcontractor contracting for any part of the contract work which may require or involve the employment of laborers or mechanics shall require or permit any such laborer or mechanic in any work week in which he or she is employed on such work to in excess of forty hours in such workweek unless such laborer or mechanic receives compensation at a rate not less than one and one-half times the basic rate of pay for all hours worked in excess of forty hours in such workweek.
- (2) Violation; liability for unpaid wages; liquidated damages. In the event of any violation of the clause set forth in paragraph (b) (1) of this section the contractor and any subcontractor responsible therefore shall be liable for the unpaid wages. In addition, such contractor and subcontractor shall be liable to the United States (in the case of work done under contract for the District of Columbia or a territory, to such District or to such territory), for unliquidated damages. Such liquidated damages shall be computed with respect to each individual laborer or mechanic, including watchmen and guards, employed in violation of the clause set forth in paragraph (b)(1) of this section, in the sum of \$10 for each calendar day on which such individual was required or permitted to work in excess of the standard workweek of forty hours without payment of the overtime wages required by the clause set forth in paragraph (b)(1) of this section.
- (3) Withholding for unpaid wages and liquidated damages. The U.S. Environmental Protection Agency shall upon its own action or upon written request of an authorized representative of the Department of Labor withhold or cause to be withheld, from any moneys payable on account of work performed by the contractor or subcontractor under any such contract or any other Federal contract with the same prime contractor, or any other Federally- assisted contract subject to the Contract Work Hours and Safety Standards Act, which is held by the same prime contractor, such liabilities of such contractor or

subcontractor for unpaid wages and liquidated damages as provided in the clause set forth in paragraph (b) (2) of this section.

(4) Subcontracts. The contractor or subcontractor shall insert in any subcontracts the clauses set forth in paragraph (b)(1) through (4) of this section and also a clause requiring the subcontractors to include these clauses in any lower tier subcontracts. The prime contractor shall be responsible for compliance by any subcontractor or lower tier subcontractor with the clauses set forth in paragraphs (b)(1) through (4) of this section.

(c) In addition to the clauses contained in paragraph (b), in any contract subject only to the Contract Work Hours and Safety Standards Act and not to any of the other statutes cited in section 5.1, the Administrator of EPA shall cause or require the contracting officer to insert a clause requiring that the contractor or subcontractor shall maintain payrolls and basic payroll records during the course of the work and shall preserve them for a period of three years from the completion of the contract for all laborers and mechanics, including guards and watchmen, working on the contract. Such records shall contain the name and address of each such employee, social security number, correct classifications, hourly worked, deductions made, and actual wages paid. Further, the Administrator of EPA shall cause or require the contracting officer to insert in any such contract a clause providing that the records to be maintained under this paragraph shall be made available by the contractor or subcontractor for inspection, copying, or transcription by authorized representatives of the U.S. Environmental Protection Agency and the Department of Labor, and the contractor or subcontractor will permit such representatives to interview employees during working hours on the job. (Approved by the Office of Management and Budget under OMB control numbers 1215-0140 and 1215-0017.)

## **CERTIFICATIONS**

### **Debarred Firms**

All prime Construction Contractors shall certify that Subcontractors have not and will not be awarded to any firm that is currently on the EPA Master List of Debarred, Suspended and Voluntarily Excluded Persons in accordance with the provisions of 40 CFR 32.500(c). Debarment action is taken against a firm for noncompliance with Federal Law.

All bidders shall complete the attached certification (Attachment Number 9) and submit to the owner with the bid proposal.

### **Anti-lobbying Certification**

All prime Construction Contractors must certify (Attachment Number 10) that no appropriated funds were or will be expended for the purpose of lobbying the Executive or Legislative Branches of the Federal Government or Federal Agency concerning this contract (contract in excess of \$100,000). If the Contractor has made or agreed to make payment to influence any member of Congress in regard to award of this contract, a Disclosure Form must be completed and submitted to the owner with the bid proposal.

All prime Contractors must require all Subcontractors to submit the certification, which must also be submitted to the owner.

**CERTIFICATION REGARDING DEBARMENT,  
SUSPENSION AND OTHER RESPONSIBILITY MATTERS**

The prospective participant certifies to the best of its knowledge and belief that it and its principals:

- (a) Are not presently debarred, suspended, proposed for debarment, declared ineligible, or voluntarily excluded from covered transactions by any Federal department or agency;
- (b) Have not within a three year period preceding this proposal been convicted of or had a civil judgment rendered against them for commission of fraud or a criminal offense in connection with obtaining, attempting to obtain, or performing a public (Federal, State, or local) transaction or contract under a public transaction; violation of Federal or State antitrust statutes or commission of embezzlement, theft, forgery, bribery, falsification or destruction of records, making false statements, or receiving stolen property;
- (c) Are not presently indicted for or otherwise criminally or civilly charged by a government entity (Federal, State, or Local) with commission of any of the offenses enumerated in paragraph (1)(b) of this certification; and
- (d) Have not within a three-year period preceding this application/proposal had one or more public transactions (Federal, State, or local) terminated for cause or default.

I understand that a false statement on this certification may be grounds for rejection of this proposal or termination of the award. In addition, under 18 USC Sec. 1001, a false statement may result in a fine of up to \$10,000 or imprisonment for up to 5 years, or both.

\_\_\_\_\_  
Typed Name & Title of Authorized Representative

\_\_\_\_\_  
Signature of Authorized Representative

\_\_\_\_\_  
Date

\_\_\_\_\_ I am unable to certify to the above statements. My explanation is attached.

**CERTIFICATION REGARDING LOBBYING**  
**Certification for Contracts, Grants,**  
**Loans, and Cooperative Agreements**

The undersigned certifies, to the best of his or her knowledge and belief, that:

(1) No Federal appropriated funds have been paid or will be paid, by or on behalf of the undersigned, to any person for influencing or attempting to influence an officer or employee of an agency, a Member of Congress, an officer or employee of Congress, or an employee of a Member of Congress in connection with the awarding of any Federal contract, the making of any Federal grant, the making of any Federal loan, the entering into of any cooperative agreement, and the extension, continuation, renewal, amendment, or modification of any Federal contract, grant, loan, or cooperative agreement.

(2) If any funds other than Federal appropriated funds have been paid or will be paid to any person for influencing or attempting to influence an officer or employee of any agency, a Member of Congress, an officer or employee of Congress, or an employee of a Member of Congress in connection with this Federal contract, grant, loan, or cooperative agreement, the undersigned shall complete and submit Standard Form-LLL, "Disclosure Form to Report Lobbying," in accordance with its instructions.

(3) The undersigned shall require that the language of this certification be included in the award documents for all sub-awards at all tiers (including subcontracts, sub-grants, and contracts under grants, loans, and cooperative agreements) and that all sub-recipients shall certify and disclose accordingly.

This certification is a material representation of fact upon which reliance was placed when this transaction was made or entered into. Submission of this certification is a prerequisite for making or entering into this transaction imposed by section 1352, title 31, U.S. Code. Any person who fails to file the required certification shall be subject to a civil penalty of not less than \$10,000 and not more than \$100,000 for each such failure.

\_\_\_\_\_  
Typed Name & Title of Authorized Representative

\_\_\_\_\_  
Signature of Authorized Representative

\_\_\_\_\_  
Date

\_\_\_\_\_ I am unable to certify to the above statements. My explanation is attached.

## EPA DISADVANTAGED BUSINESS ENTERPRISE PROGRAM

EPA's Disadvantaged Business Enterprise Program rule applies to contract procurement actions funded in part by EPA assistance agreements awarded after May 27, 2008. The rule is found at Federal regulation Title 40, Part 33. Specific responsibilities are highlighted below.

### Grant recipient responsibilities:

- Conduct an Availability Analysis and negotiate fair share objectives with EPA (§33.411), or adopt the fair share objectives of the oversight state agency revolving loan fund for comparable infrastructure. (§33.405(b)(3)).
- Include the Appendix A term and condition in each contract with a primary contractor (§3.106). The term and condition is included in the EPA Region 4 contract specifications insert *FEDERAL REQUIREMENTS AND CONTRACT PROVISIONS FOR SPECIAL APPROPRIATION ACT PROJECTS US ENVIRONMENTAL PROTECTION AGENCY, Region III, June 2008*.
- Employ the six Good Faith Efforts during prime contractor procurement (§33.301).
- Require prime contractor to comply with the following prime contractor requirements of Title 40 Part 33:
  - To employ the six Good Faith Efforts steps in paragraphs (a) through (e) of §33.301 if the prime contractor awards subcontracts (§33.301(f)).
  - To provide EPA form 6100-2 – *DBE Subcontractor Participation Form* to all DBE subcontractors (§33.302(e)).
  - To submit EPA forms 6100-3 – *DBE Program Subcontractor Performance Form* and 6100-4 – *DBE Program Subcontractor Utilization Form* with bid package or proposal. (§33.302 (f) and (g)).
  - To pay its subcontractor for satisfactory performance no more than 30 days from the prime contractor's receipt of payment from the recipient (§33.302(a)).
  - To notify recipient in writing by its prime contractor prior to any termination of a DBE subcontractor for convenience by the prime contractor (§33.302(b)).
  - To employ the six good faith efforts described in §33.301 if soliciting a replacement subcontractor after a DBE subcontractor fails to complete work under the subcontract for any reason. (§33.302(c)).
  - To employ the six good faith efforts described in §33.301 even if the prime contractor has achieved its fair share objectives under subpart D of Part 33. (§33.302(d)).

- Semiannually complete and submit to Charles Hayes, EPA Region 4 DBE Coordinator EPA form 5700-52A summarizing DBE participation achieved during the previous six months (§33.502).
- Maintain records documenting its compliance with the requirements of Title 40 Part 33, including documentation of its, and its prime contractors', good faith efforts (§33.501(a)).

**Prime Contractor Responsibilities:**

- Employ the six Good Faith Efforts steps in paragraphs (a) through (e) of §33.301 if the prime contractor awards subcontracts (§33.301(f)).
- Provide EPA form number 6100-2 – *DBE Program Subcontractor Participation Form* and form number 6100-3 – *DBE Program Subcontractor Performance Form* to each DBE subcontractor prior to opening of the contractor's bid or proposal (§33.302(e) and (f)).
- Complete EPA form number 6100-4 – *DBE Program Subcontractor Utilization Form* (§33.302(g)).
- Submit to recipient with it bid package or proposal the completed EPA form number 6100-4, plus an EPA form number 6100-3 for each DBE subcontractor used in the contractor's bid or proposal (§33.302(f) and (g)).
- Pay subcontractors for satisfactory performance no more than 30 days from the prime contractor's receipt of payment from the recipient (§33.302(a)).
- Notify the recipient in writing prior to prime contractor termination of a DBE subcontractor for convenience (§33.302(b)).
- Employ the six good faith efforts described in §33.301 if soliciting a replacement subcontractor after a DBE subcontractor fails to complete work under the subcontract for any reason. (§33.302(c)).
- Employ the six good faith efforts described in §33.301 even if the prime contractor has achieved its fair share objectives under subpart D of Part 33. (§33.302(d)).
- Semiannually inform recipient of DBE participation achieved (§33.502).
- Maintain records documenting its compliance with the requirements of Title 40 Part 33, including documentation of its, and its prime contractors', good faith efforts (§33.501(a)).



**Subcontractor Responsibilities:**

- May submit EPA form 6100-2 – *DBE Subcontractor Participation Form* to Charles Hayes, EPA Region 4 DBE Coordinator (§33.302(e)).
- Must complete EPA form 6100-3 – *DBE Program Subcontractor Performance Form*, and submit it to the prime contractor soliciting services from the subcontractor prior to the opening of bids for the prime contract.

**SPAP Requirements:**

Form	Requirement	Provided By:	Completed By:	Submitted To:
EPA Form 6100-2	Grant Recipients required to have prime contractors provide form to Subcontractors	Prime Contractors	DBE Subcontractors	EPA Region 4 DBE Coordinator Charles Hayes
EPA Form 6100-3	Grant Recipients required to have prime contractors provide form to Subcontractors	Prime Contractors	DBE Subcontractors	Grant Recipients as part of a bid or proposal package
EPA Form 6100-4	Grant Recipients required to have prime contractors complete the form	Grant Recipients	Prime Contractors	Grant Recipients as part of a bid or proposal package

**SRF Requirements:**

Form	Requirement	Provided By:	Completed By:	Submitted To:
EPA Form 6100-2	Recipients required to have prime contractors provide form to Subcontractors	Prime Contractors	DBE Subcontractors	DOW Project Administrator
EPA Form 6100-3	Recipients required to have prime contractors provide form to Subcontractors	Prime Contractors	DBE Subcontractors	Dow Project Administrator w/ATA Package
EPA Form 6100-4	Recipients required to have prime contractors complete the form	Recipients	Prime Contractors	DOW Project Administrator w/ATA Package
Pay Request DBE Form	Recipients required to have prime contractors complete the form	Recipients	Prime Contractors	DOW Project Administrator w/EACH PAYMENT

# DISADVANTAGED BUSINESS ENTERPRISE PARTICIPATION POLICY

PROJECT NAME: \_\_\_\_\_ BID DATE: \_\_\_\_\_

**1. Name, address and telephone number of contact person on all DBE matters:**

Prime Contractor's Name: \_\_\_\_\_  
Contact Person: \_\_\_\_\_  
Address: \_\_\_\_\_  
Phone: \_\_\_\_\_  
Cell Phone: \_\_\_\_\_  
Email: \_\_\_\_\_  
Total Contract Amount: \_\_\_\_\_

**2. Total dollar amount/percent of contract of MBE participation:** \_\_\_\_\_

**3. Total dollar amount/percent of contract of WBE participation:** \_\_\_\_\_

**4. Are certifications\* for each MBE/WBE/DBE subcontractor enclosed; if no, please explain:**  Yes  No

**5. Are MBE/WBE/DBE subcontracts or letters of intent signed by both parties enclosed; if no, please explain:**  Yes  No

**6. List of MBE Subcontractors:**

Name: \_\_\_\_\_  
Contact Person: \_\_\_\_\_  
Address: \_\_\_\_\_  
Phone: \_\_\_\_\_  
Cell Phone: \_\_\_\_\_  
Email: \_\_\_\_\_  
Type of Contract: \_\_\_\_\_  
Work to be Done: \_\_\_\_\_  
Amount: \_\_\_\_\_

**7. List of WBE Subcontractors:**

Name: \_\_\_\_\_  
Contact Person: \_\_\_\_\_  
Address: \_\_\_\_\_  
Phone: \_\_\_\_\_  
Cell Phone: \_\_\_\_\_  
Email: \_\_\_\_\_  
Type of Contract: \_\_\_\_\_  
Work to be Done: \_\_\_\_\_  
Amount: \_\_\_\_\_

Attach Additional Sheets, If Necessary

\*Self-certification: Self certification of MBE/WBE/DBE firms will NOT be accepted as a valid form of certification of MBE/WBE/DBE status.

8. **Information and documentation concerning efforts taken to comply with EPA's "six good faith efforts"**

- (i). Ensure DBE construction firms or material suppliers are made aware of contracting opportunities to the fullest extent practicable through outreach and recruitment activities; including placing DBEs on solicitation lists and soliciting them whenever they are potential sources. A good source for a list of DBEs is the Kentucky Transportation's website: <http://transportation.ky.gov/Civil-Rights-and-Small-Business-Development/Pages/Certified-DBE-Directory.aspx>.
- The prime contractor certifies that a bidders list (see example sheet below) of qualified vendors, including DBEs, was developed for current and future solicitations and that the list will be maintained. *Submit a copy of the list as documentation.*
- (ii). Make information on forthcoming opportunities available to DBEs and arrange time frames for contracts and establish delivery schedules, where the requirements permit, in a way that encourages and facilitates participation by DBEs in the competitive process; including, whenever possible, posting solicitation for bids or proposals for a sufficient amount of time as to receive a competitive bid or proposal pool.
- The prime contractor certifies that every opportunity was provided to a number of DBEs to encourage their participation in the competitive process and that an adequate amount of time was provided for response.
- a. List each DBE construction firm or material supplier to which a solicitation was attempted. *Submit copies of letters, emails, faxes, telecommunication logs, certified mail receipts, returned envelopes, certified mail return receipts, etc. as documentation.*
- Company name and phone number: \_\_\_\_\_  
Area of work expertise: \_\_\_\_\_  
Date of any follow-ups and person spoke to: \_\_\_\_\_
- b. Advertisements, if applicable: List each publication in which an announcement or notification was placed. *Submit a tear sheet of each announcement from each publication as documentation.*
- Name of publication: \_\_\_\_\_  
Date(s) of advertisement: \_\_\_\_\_  
Specific subcontract areas announced: \_\_\_\_\_
- c. Other, if applicable: List each notification method in which an announcement or outreach was used; list serve, public meeting, etc. *Submit applicable information to document effort.*
- Method of notification: \_\_\_\_\_  
Date(s) of notification: \_\_\_\_\_
- (iii). Consider in the contracting process whether firms competing for large contracts could subcontract with DBEs; including dividing total requirements, when economically feasible, into smaller tasks or quantities to permit maximum participation by DBEs in the competitive process.
- The prime contractor certifies that the project was broken into its basic elements (i.e., dirt hauling, landscaping, painting, pipe installation, material supplies, etc.) and that a determination was made whether it's economically feasible to bid the elements separately and that the analysis of this effort was documented with a short memo to the project file.

(iv). Establishing delivery schedules, where the requirement permits, which encourage participation by small and minority business, and women's business enterprises.

The prime contractor certifies that they established delivery schedules which would allow DBEs to participate in the projects.

(v). Use the services and assistance of the Small Business Administration (SBA) and the Minority Business Development Agency (MBDA) of the U.S. Department of Commerce. The easiest way to utilize the services of SBA and MBDA is to visit their websites: [www.sba.gov](http://www.sba.gov) and [www.mbda.gov](http://www.mbda.gov) and use the electronic tools available there or you may send the nearest SBA and MBDA office a certified letter that generally describes the solicitation, the dates it will be open, the types of vendors you are seeking and applicable Standard Industrial Classification (SIC) or North American Industry Classification System (NAIC) codes if known. You may also use the services and assistance of the Procurement Technical Assistance Center (PTAC). The easiest way to utilize the services of PTAC is to send an email: [ptac@ksbdc.org](mailto:ptac@ksbdc.org) and generally describe the solicitation, the dates it will be open, the types of vendors you are seeking and applicable SIC or NAIC codes if known.

The prime contractor certifies that the assistance of the SBA, MBDA, and/or PTAC was utilized. *Submit pages printed off the SBA and MBDA websites which evidence efforts to register a solicitation on those sites or submit copies of the letter sent and certified mail receipt as documentation; submit copies of emails with PTAC as documentation.*

(vi). If a subcontractor awards any subcontracts, require the subcontractor to take the steps in numbers (i) through (v) above.

The prime contractor certifies that subcontractors used for this project will be required to follow the steps of the "six good faith efforts" as listed above.

**9. Signature and date:**

To the best of my knowledge and belief, all "six good faith efforts" have been met and the information contained in this document is true and correct; the document has been duly authorized by the legal representative.

\_\_\_\_\_  
Signature

\_\_\_\_\_  
Print name and title

\_\_\_\_\_  
Date



**BONDS AND INSURANCE**

The minimum requirements shall be as follows:

Bonding requirements for contracts of \$100,000 or less are contained in 40 CFR 31.36(h).

Bond requirements for contracts in excess of \$100,000 are:

- Bid guarantee equivalent to five percent of the bid price. The bid guarantee shall consist of a firm commitment such as a certified check or bid bond submitted with the bid;
- Performance bond equal to 100 percent of the contract price, and
- Payment bond equal to 100 percent of the contract price. Bonds must be obtained from companies holding Certificates of Authority as acceptable sureties, issued by the U.S. Treasury.

Insurance requirements are contained in the General Conditions of the contract. In addition to the other required insurance, the owner or the contractor, as appropriate, must acquire any flood insurance made available by the Federal Emergency Management Agency as required by 44 CFR Parts 59-79, if construction will take place in a flood hazard area identified by the Federal Emergency Management Agency. The owner's requirements on Flood Insurance are contained in the Special Conditions Section of the Contracts Documents.

**NOTICE OF INTENT**

All construction projects with surface disturbance of more than 1 acre during the period of construction must have a KPDES Storm Water General Permit. The permit can be found at the following web address:  
<https://dep.gateway.kv.gov/eForms/default.aspx?FormID=7>.

If you have any questions regarding the completion of this form call the Surface Water Permits Branch, at (502) 564-3410.

### **Davis-Bacon Wage Rate Requirements**

**CWSRF:** The recipient agrees to include in all agreements to provide assistance for the construction of treatment works carried out in whole or in part with such assistance made available by a State water pollution control revolving fund as authorized by title VI of the Federal Water Pollution Control Act (33 U.S.C. 1381 et seq.), or with such assistance made available under section 205(m) of that Act (33 U.S.C. 1285(m)), or both, a term and condition requiring compliance with the requirements of section 513 of that Act (33 U.S.C. 1372) in all procurement contracts and sub-grants, and require that loan recipients, procurement contractors and sub-grantees include such a term and condition in subcontracts and other lower tiered transactions. All contracts and subcontracts for the construction of treatment works carried out in whole or in part with assistance made available as stated herein shall insert in full in any contract in excess of \$2,000 the contract clauses as set forth below titled "Wage Rate Requirements Under The Consolidated and Further Continuing Appropriations Act, 2013 (P.L. 113-6)". This term and condition applies to all agreements to provide assistance under the authorities referenced herein, whether in the form of a loan, bond purchase, grant, or any other vehicle to provide financing for a project, where such agreements are executed on or after October 30, 2009.

**DWSRF:** The recipient agrees to include in all agreements to provide assistance for any construction project carried out in whole or in part with such assistance made available by a drinking water treatment revolving loan fund as authorized by section 1452 of the Safe Drinking Water Act (42 U.S.C. 300j-12), a term and condition requiring compliance with the requirements of section 1450(e) of the Safe Drinking Water Act (42 U.S.C.300j-9(e)) in all procurement contracts and sub-grants, and require that loan recipients, procurement contractors and sub-grantees include such a term and condition in subcontracts and other lower tiered transactions All contracts and subcontracts for any construction project carried out in whole or in part with assistance made available as stated herein shall insert in full in any contract in excess of \$2,000 the contract clauses as set forth below entitled "Wage Rate Requirements Under The Consolidated and Further Continuing Appropriations Act, 2013 (P.L. 113-6)". This term and condition applies to all agreements to provide assistance under the authorities referenced herein, whether in the form of a loan, bond purchase, grant, or any other vehicle to provide financing for a project, where such agreements are executed on or after October 30, 2009.

### **Wage Rate Requirements Under The Consolidated and Further Continuing Appropriations Act, 2013 (P.L. 113-6)**

#### **Preamble**

With respect to the Clean Water and Safe Drinking Water State Revolving Funds, EPA provides capitalization grants to each State which in turn provides subgrants or loans to eligible entities within the State. Typically, the subrecipients are municipal or other local governmental entities that manage the funds. For these types of recipients, the provisions set forth under Roman Numeral I, below, shall apply. Although EPA and the State remain responsible for ensuring subrecipients' compliance with the wage rate requirements set forth herein, those subrecipients shall have the primary responsibility to maintain payroll records as described in Section 3(ii)(A), below and for compliance as described in Section I-5.



Occasionally, the subrecipient may be a private for profit or not for profit entity. For these types of recipients, the provisions set forth in Roman Numeral II, below, shall apply. Although EPA and the State remain responsible for ensuring subrecipients' compliance with the wage rate requirements set forth herein, those subrecipients shall have the primary responsibility to maintain payroll records as described in Section II-3(ii)(A), below and for compliance as described in Section II-5.

**I. Requirements Under The Consolidated and Further Continuing Appropriations Act, 2013 (P.L. 113-6) For Subrecipients That Are Governmental Entities:**

The following terms and conditions specify how recipients will assist EPA in meeting its Davis-Bacon (DB) responsibilities when DB applies to EPA awards of financial assistance under the FY 2013 Continuing Resolution with respect to State recipients and subrecipients that are governmental entities. If a subrecipient has questions regarding when DB applies, obtaining the correct DB wage determinations, DB provisions, or compliance monitoring, it may contact the State recipient. The recipient or subrecipient may also obtain additional guidance from DOL's website at <http://www.dol.gov/whd/>

**1. Applicability of the Davis- Bacon (DB) prevailing wage requirements.**

Under the FY 2013 Continuing Resolution, DB prevailing wage requirements apply to the construction, alteration, and repair of treatment works carried out in whole or in part with assistance made available by a State water pollution control revolving fund and to any construction project carried out in whole or in part by assistance made available by a drinking water treatment revolving loan fund. If a subrecipient encounters a unique situation at a site that presents uncertainties regarding DB applicability, the subrecipient must discuss the situation with the recipient State before authorizing work on that site.

**2. Obtaining Wage Determinations.**

(a) Subrecipients shall obtain the wage determination for the locality in which a covered activity subject to DB will take place prior to issuing requests for bids, proposals, quotes or other methods for soliciting contracts (solicitation) for activities subject to DB. These wage determinations shall be incorporated into solicitations and any subsequent contracts. Prime contracts must contain a provision requiring that subcontractors follow the wage determination incorporated into the prime contract.

(i) While the solicitation remains open, the subrecipient shall monitor [www.wdol.gov](http://www.wdol.gov) weekly to ensure that the wage determination contained in the solicitation remains current. The subrecipients shall amend the solicitation if DOL issues a modification more than 10 days prior to the closing date (i.e. bid opening) for the solicitation. If DOL modifies or supersedes the applicable wage determination less than 10 days prior to the closing date, the subrecipients may request a finding from the State recipient that there is not a reasonable time to notify interested contractors of the modification of the wage determination. The State recipient will provide a report of its findings to the subrecipient.

(ii) If the subrecipient does not award the contract within 90 days of the closure of the solicitation, any modifications or supersedes DOL makes to the wage determination contained in the solicitation shall be effective unless the State recipient, at the request of the subrecipient, obtains an extension of the 90 day period from DOL pursuant to 29 CFR 1.6(c)(3)(iv). The subrecipient shall monitor [www.wdol.gov](http://www.wdol.gov) on a weekly basis if it does not award the contract within 90 days of closure of the solicitation to ensure that wage determinations contained in the solicitation remain current.

(b) If the subrecipient carries out activity subject to DB by issuing a task order, work assignment or similar instrument to an existing contractor (ordering instrument) rather than by publishing a solicitation, the subrecipient shall insert the appropriate DOL wage determination from [www.wdol.gov](http://www.wdol.gov) into the ordering instrument.

(c) Subrecipients shall review all subcontracts subject to DB entered into by prime contractors to verify that the prime contractor has required its subcontractors to include the applicable wage determinations.

(d) As provided in 29 CFR 1.6(f), DOL may issue a revised wage determination applicable to a subrecipient's contract after the award of a contract or the issuance of an ordering instrument if DOL determines that the subrecipient has failed to incorporate a wage determination or has used a wage determination that clearly does not apply to the contract or ordering instrument. If this occurs, the subrecipient shall either terminate the contract or ordering instrument and issue a revised solicitation or ordering instrument or incorporate DOL's wage determination retroactive to the beginning of the contract or ordering instrument by change order. The subrecipient's contractor must be compensated for any increases in wages resulting from the use of DOL's revised wage determination.

### **3. Contract and Subcontract provisions.**

(a) The Recipient shall insure that the subrecipient(s) shall insert in full in any contract in excess of \$2,000 which is entered into for the actual construction, alteration and/or repair, including painting and decorating, of a treatment work under the CWSRF or a construction project under the DWSRF financed in whole or in part from Federal funds or in accordance with guarantees of a Federal agency or financed from funds obtained by pledge of any contract of a Federal agency to make a loan, grant or annual contribution (except where a different meaning is expressly indicated), and which is subject to the labor standards provisions of any of the acts listed in § 5.1 or the FY 2013 Continuing Resolution, the following clauses:

#### **(1) Minimum wages.**

(i) All laborers and mechanics employed or working upon the site of the work will be paid unconditionally and not less often than once a week, and without subsequent deduction or rebate on any account (except such payroll deductions as are permitted by regulations issued by the Secretary of Labor under the Copeland Act (29 CFR part 3)), the full amount of wages and bona fide fringe benefits (or cash equivalents thereof) due at time of payment computed at rates not less than those contained in the wage determination of the Secretary of Labor which is attached hereto and made a part hereof, regardless of any contractual relationship which may be alleged to exist between the contractor and such laborers and mechanics.

Contributions made or costs reasonably anticipated for bona fide fringe benefits under section 1(b)(2) of the Davis-Bacon Act on behalf of laborers or mechanics are considered wages paid to such laborers or mechanics, subject to the provisions of paragraph (a)(1)(iv) of this section; also, regular contributions made or costs incurred for more than a weekly period (but not less often than quarterly) under plans, funds, or programs which cover the particular weekly period, are deemed to be constructively made or incurred during such weekly period. Such laborers and mechanics shall be paid the appropriate wage rate and fringe benefits on the wage determination for the classification of work actually performed, without regard to skill, except as provided in § 5.5(a)(4). Laborers or mechanics performing work in more than one classification may be compensated at the rate specified for each classification for the time actually worked therein: Provided, that the employer's payroll records accurately set forth the time spent in each classification in which work is performed. The wage determination (including any additional classification and wage rates conformed under paragraph (a)(1)(ii) of this section) and the Davis-Bacon poster (WH-1321) shall be posted at all times by the contractor and its subcontractors at the site of the work in a prominent and accessible place where it can be easily seen by the workers.

Subrecipients may obtain wage determinations from the U.S. Department of Labor's website, [www.dol.gov](http://www.dol.gov).

(ii)(A) The subrecipient(s), on behalf of EPA, shall require that any class of laborers or mechanics, including helpers, which is not listed in the wage determination and which is to be employed under the contract shall be classified in conformance with the wage determination. The State award official shall approve a request for an additional classification and wage rate and fringe benefits therefore only when the following criteria have been met:

- (1) The work to be performed by the classification requested is not performed by a classification in the wage determination; and
- (2) The classification is utilized in the area by the construction industry; and
- (3) The proposed wage rate, including any bona fide fringe benefits, bears a reasonable relationship to the wage rates contained in the wage determination.

(B) If the contractor and the laborers and mechanics to be employed in the classification (if known), or their representatives, and the subrecipient(s) agree on the classification and wage rate (including the amount designated for fringe benefits where appropriate), documentation of the action taken and the request, including the local wage determination shall be sent by the subrecipient (s) to the State award official. The State award official will transmit the request, to the Administrator of the Wage and Hour Division, Employment Standards Administration, U.S. Department of Labor, Washington, DC 20210 and to the EPA DB Regional Coordinator concurrently. The Administrator, or an authorized representative, will approve, modify, or disapprove every additional classification request within 30 days of receipt and so advise the State award official or will notify the State award official within the 30-day period that additional time is necessary.

(C) In the event the contractor, the laborers or mechanics to be employed in the classification or their representatives, and the subrecipient(s) do not agree on the proposed classification and wage rate (including the amount designated for fringe benefits, where appropriate), the award official shall refer the request and the local wage determination, including the views of all

interested parties and the recommendation of the State award official, to the Administrator for determination. The request shall be sent to the EPA DB Regional Coordinator concurrently. The Administrator, or an authorized representative, will issue a determination within 30 days of receipt of the request and so advise the contracting officer or will notify the contracting officer within the 30-day period that additional time is necessary.

(D) The wage rate (including fringe benefits where appropriate) determined pursuant to paragraphs (a)(1)(ii)(B) or (C) of this section, shall be paid to all workers performing work in the classification under this contract from the first day on which work is performed in the classification.

(iii) Whenever the minimum wage rate prescribed in the contract for a class of laborers or mechanics includes a fringe benefit which is not expressed as an hourly rate, the contractor shall either pay the benefit as stated in the wage determination or shall pay another bona fide fringe benefit or an hourly cash equivalent thereof.

(iv) If the contractor does not make payments to a trustee or other third person, the contractor may consider as part of the wages of any laborer or mechanic the amount of any costs reasonably anticipated in providing bona fide fringe benefits under a plan or program, Provided, That the Secretary of Labor has found, upon the written request of the contractor, that the applicable standards of the Davis-Bacon Act have been met. The Secretary of Labor may require the contractor to set aside in a separate account assets for the meeting of obligations under the plan or program.

(2) Withholding. The subrecipient(s), shall upon written request of the EPA Award Official or an authorized representative of the Department of Labor, withhold or cause to be withheld from the contractor under this contract or any other Federal contract with the same prime contractor, or any other federally-assisted contract subject to Davis-Bacon prevailing wage requirements, which is held by the same prime contractor, so much of the accrued payments or advances as may be considered necessary to pay laborers and mechanics, including apprentices, trainees, and helpers, employed by the contractor or any subcontractor the full amount of wages required by the contract. In the event of failure to pay any laborer or mechanic, including any apprentice, trainee, or helper, employed or working on the site of the work, all or part of the wages required by the contract, the (Agency) may, after written notice to the contractor, sponsor, applicant, or owner, take such action as may be necessary to cause the suspension of any further payment, advance, or guarantee of funds until such violations have ceased.

(3) Payrolls and basic records.

(i) Payrolls and basic records relating thereto shall be maintained by the contractor during the course of the work and preserved for a period of three years thereafter for all laborers and mechanics working at the site of the work. Such records shall contain the name, address, and social security number of each such worker, his or her correct classification, hourly rates of wages paid (including rates of contributions or costs anticipated for bona fide fringe benefits or cash equivalents thereof of the types described in section 1(b)(2)(B) of the Davis-Bacon Act), daily and weekly number of hours worked, deductions made and actual wages paid. Whenever the Secretary of Labor has found under 29 CFR 5.5(a)(1)(iv) that the wages of any laborer or mechanic include the amount of any costs reasonably anticipated in providing benefits under a plan or program described in section 1(b)(2)(B) of the Davis-Bacon Act, the contractor shall maintain records which show that the commitment to provide such benefits is enforceable, that

the plan or program is financially responsible, and that the plan or program has been communicated in writing to the laborers or mechanics affected, and records which show the costs anticipated or the actual cost incurred in providing such benefits. Contractors employing apprentices or trainees under approved programs shall maintain written evidence of the registration of apprenticeship programs and certification of trainee programs, the registration of the apprentices and trainees, and the ratios and wage rates prescribed in the applicable programs.

(ii)(A) The contractor shall submit weekly, for each week in which any contract work is performed, a copy of all payrolls to the subrecipient, that is, the entity that receives the sub-grant or loan from the State capitalization grant recipient. Such documentation shall be available on request of the State recipient or EPA. As to each payroll copy received, the subrecipient shall provide written confirmation in a form satisfactory to the State indicating whether or not the project is in compliance with the requirements of 29 CFR 5.5(a)(1) based on the most recent payroll copies for the specified week. The payrolls shall set out accurately and completely all of the information required to be maintained under 29 CFR 5.5(a)(3)(i), except that full social security numbers and home addresses shall not be included on the weekly payrolls. Instead the payrolls shall only need to include an individually identifying number for each employee (e.g., the last four digits of the employee's social security number). The required weekly payroll information may be submitted in any form desired. Optional Form WH-347 is available for this purpose from the Wage and Hour Division Web site at <http://www.dol.gov/whd/forms/wh347instr.htm> or its successor site. The prime contractor is responsible for the submission of copies of payrolls by all subcontractors. Contractors and subcontractors shall maintain the full social security number and current address of each covered worker, and shall provide them upon request to the subrecipient(s) for transmission to the State or EPA if requested by EPA, the State, the contractor, or the Wage and Hour Division of the Department of Labor for purposes of an investigation or audit of compliance with prevailing wage requirements. It is not a violation of this section for a prime contractor to require a subcontractor to provide addresses and social security numbers to the prime contractor for its own records, without weekly submission to the subrecipient(s).

(B) Each payroll submitted shall be accompanied by a "Statement of Compliance," signed by the contractor or subcontractor or his or her agent who pays or supervises the payment of the persons employed under the contract and shall certify the following:

(1) That the payroll for the payroll period contains the information required to be provided under §5.5 (a)(3)(ii) of Regulations, 29 CFR part 5, the appropriate information is being maintained under §5.5 (a)(3)(i) of Regulations, 29 CFR part 5, and that such information is correct and complete;

(2) That each laborer or mechanic (including each helper, apprentice, and trainee) employed on the contract during the payroll period has been paid the full weekly wages earned, without rebate, either directly or indirectly, and that no deductions have been made either directly or indirectly from the full wages earned, other than permissible deductions as set forth in Regulations, 29 CFR part 3;

(3) That each laborer or mechanic has been paid not less than the applicable wage rates and fringe benefits or cash equivalents for the classification of work performed, as specified in the applicable wage determination incorporated into the contract.

(C) The weekly submission of a properly executed certification set forth on the reverse side of Optional Form WH-347 shall satisfy the requirement for submission of the "Statement of Compliance" required by paragraph (a)(3)(ii)(B) of this section.

(D) The falsification of any of the above certifications may subject the contractor or subcontractor to civil or criminal prosecution under section 1001 of title 18 and section 231 of title 31 of the United States Code.

(iii) The contractor or subcontractor shall make the records required under paragraph (a)(3)(i) of this section available for inspection, copying, or transcription by authorized representatives of the State, EPA or the Department of Labor, and shall permit such representatives to interview employees during working hours on the job. If the contractor or subcontractor fails to submit the required records or to make them available, the Federal agency or State may, after written notice to the contractor, sponsor, applicant, or owner, take such action as may be necessary to cause the suspension of any further payment, advance, or guarantee of funds. Furthermore, failure to submit the required records upon request or to make such records available may be grounds for debarment action pursuant to 29 CFR 5.12.

(4) Apprentices and trainees.

(i) Apprentices. Apprentices will be permitted to work at less than the predetermined rate for the work they performed when they are employed pursuant to and individually registered in a bona fide apprenticeship program registered with the U.S. Department of Labor, Employment and Training Administration, Office of Apprenticeship Training, Employer and Labor Services, or with a State Apprenticeship Agency recognized by the Office, or if a person is employed in his or her first 90 days of probationary employment as an apprentice in such an apprenticeship program, who is not individually registered in the program, but who has been certified by the Office of Apprenticeship Training, Employer and Labor Services or a State Apprenticeship Agency (where appropriate) to be eligible for probationary employment as an apprentice. The allowable ratio of apprentices to journeymen on the job site in any craft classification shall not be greater than the ratio permitted to the contractor as to the entire work force under the registered program. Any worker listed on a payroll at an apprentice wage rate, who is not registered or otherwise employed as stated above, shall be paid not less than the applicable wage rate on the wage determination for the classification of work actually performed. In addition, any apprentice performing work on the job site in excess of the ratio permitted under the registered program shall be paid not less than the applicable wage rate on the wage determination for the work actually performed. Where a contractor is performing construction on a project in a locality other than that in which its program is registered, the ratios and wage rates (expressed in percentages of the journeyman's hourly rate) specified in the contractor's or subcontractor's registered program shall be observed. Every apprentice must be paid at not less than the rate specified in the registered program for the apprentice's level of progress, expressed as a percentage of the journeymen hourly rate specified in the applicable wage determination. Apprentices shall be paid fringe benefits in accordance with the provisions of the apprenticeship program. If the apprenticeship program does not specify fringe benefits, apprentices must be paid the full amount of fringe benefits listed on the wage determination for the applicable classification. If the Administrator determines that a different practice prevails for the applicable apprentice classification, fringes shall be paid in accordance with that determination. In the event the Office of Apprenticeship Training, Employer and Labor Services, or a State Apprenticeship Agency recognized by the Office, withdraws approval of an apprenticeship program, the contractor will

no longer be permitted to utilize apprentices at less than the applicable predetermined rate for the work performed until an acceptable program is approved.

(ii) Trainees. Except as provided in 29 CFR 5.16, trainees will not be permitted to work at less than the predetermined rate for the work performed unless they are employed pursuant to and individually registered in a program which has received prior approval, evidenced by formal certification by the U.S. Department of Labor, Employment and Training Administration. The ratio of trainees to journeymen on the job site shall not be greater than permitted under the plan approved by the Employment and Training Administration. Every trainee must be paid at not less than the rate specified in the approved program for the trainee's level of progress, expressed as a percentage of the journeyman hourly rate specified in the applicable wage determination. Trainees shall be paid fringe benefits in accordance with the provisions of the trainee program. If the trainee program does not mention fringe benefits, trainees shall be paid the full amount of fringe benefits listed on the wage determination unless the Administrator of the Wage and Hour Division determines that there is an apprenticeship program associated with the corresponding journeyman wage rate on the wage determination which provides for less than full fringe benefits for apprentices. Any employee listed on the payroll at a trainee rate who is not registered and participating in a training plan approved by the Employment and Training Administration shall be paid not less than the applicable wage rate on the wage determination for the classification of work actually performed. In addition, any trainee performing work on the job site in excess of the ratio permitted under the registered program shall be paid not less than the applicable wage rate on the wage determination for the work actually performed. In the event the Employment and Training Administration withdraws approval of a training program, the contractor will no longer be permitted to utilize trainees at less than the applicable predetermined rate for the work performed until an acceptable program is approved.

(iii) Equal employment opportunity. The utilization of apprentices, trainees and journeymen under this part shall be in conformity with the equal employment opportunity requirements of Executive Order 11246, as amended, and 29 CFR part 30.

(5) Compliance with Copeland Act requirements. The contractor shall comply with the requirements of 29 CFR part 3, which are incorporated by reference in this contract.

(6) Subcontracts. The contractor or subcontractor shall insert in any subcontracts the clauses contained in 29 CFR 5.5(a)(1) through (10) and such other clauses as the EPA determines may be appropriate, and also a clause requiring the subcontractors to include these clauses in any lower tier subcontracts. The prime contractor shall be responsible for the compliance by any subcontractor or lower tier subcontractor with all the contract clauses in 29 CFR 5.5.

(7) Contract termination; debarment. A breach of the contract clauses in 29 CFR 5.5 may be grounds for termination of the contract, and for debarment as a contractor and a subcontractor as provided in 29 CFR 5.12.

(8) Compliance with Davis-Bacon and Related Act requirements. All rulings and interpretations of the Davis-Bacon and Related Acts contained in 29 CFR parts 1, 3, and 5 are herein incorporated by reference in this contract.

(9) Disputes concerning labor standards. Disputes arising out of the labor standards provisions of this contract shall not be subject to the general disputes clause of this contract. Such disputes shall be resolved in accordance with the procedures of the Department of Labor set forth in 29

CFR parts 5, 6, and 7. Disputes within the meaning of this clause include disputes between the contractor (or any of its subcontractors) and Subrecipient(s), State, EPA, the U.S. Department of Labor, or the employees or their representatives.

(10) Certification of eligibility.

(i) By entering into this contract, the contractor certifies that neither it (nor he or she) nor any person or firm who has an interest in the contractor's firm is a person or firm ineligible to be awarded Government contracts by virtue of section 3(a) of the Davis-Bacon Act or 29 CFR 5.12(a)(1).

(ii) No part of this contract shall be subcontracted to any person or firm ineligible for award of a Government contract by virtue of section 3(a) of the Davis-Bacon Act or 29 CFR 5.12(a)(1).

(iii) The penalty for making false statements is prescribed in the U.S. Criminal Code, 18 U.S.C. 1001.

**4. Contract Provision for Contracts in Excess of \$100,000.**

(a) Contract Work Hours and Safety Standards Act. The subrecipient shall insert the following clauses set forth in paragraphs (a)(1), (2), (3), and (4) of this section in full in any contract in an amount in excess of \$100,000 and subject to the overtime provisions of the Contract Work Hours and Safety Standards Act. These clauses shall be inserted in addition to the clauses required by Item 3, above or 29 CFR 4.6. As used in this paragraph, the terms laborers and mechanics include watchmen and guards.

(1) Overtime requirements. No contractor or subcontractor contracting for any part of the contract work which may require or involve the employment of laborers or mechanics shall require or permit any such laborer or mechanic in any workweek in which he or she is employed on such work to work in excess of forty hours in such workweek unless such laborer or mechanic receives compensation at a rate not less than one and one-half times the basic rate of pay for all hours worked in excess of forty hours in such workweek.

(2) Violation; liability for unpaid wages; liquidated damages. In the event of any violation of the clause set forth in paragraph (a)(1) of this section the contractor and any subcontractor responsible therefore shall be liable for the unpaid wages. In addition, such contractor and subcontractor shall be liable to the United States (in the case of work done under contract for the District of Columbia or a territory, to such District or to such territory), for liquidated damages. Such liquidated damages shall be computed with respect to each individual laborer or mechanic, including watchmen and guards, employed in violation of the clause set forth in paragraph (a)(1) of this section, in the sum of \$10 for each calendar day on which such individual was required or permitted to work in excess of the standard workweek of forty hours without payment of the overtime wages required by the clause set forth in paragraph (a)(1) of this section.

(3) Withholding for unpaid wages and liquidated damages. The subrecipient, upon written request of the EPA Award Official or an authorized representative of the Department of Labor, shall withhold or cause to be withheld, from any moneys payable on account of work performed by the contractor or subcontractor under any such contract or any other Federal contract with the same prime contractor, or any other federally-assisted contract subject to the Contract Work Hours and Safety Standards Act, which is held by the same prime contractor, such sums as may



be determined to be necessary to satisfy any liabilities of such contractor or subcontractor for unpaid wages and liquidated damages as provided in the clause set forth in paragraph (b)(2) of this section.

(4) Subcontracts. The contractor or subcontractor shall insert in any subcontracts the clauses set forth in paragraph (a)(1) through (4) of this section and also a clause requiring the subcontractors to include these clauses in any lower tier subcontracts. The prime contractor shall be responsible for compliance by any subcontractor or lower tier subcontractor with the clauses set forth in paragraphs (a)(1) through (4) of this section.

(b) In addition to the clauses contained in Item 3, above, in any contract subject only to the Contract Work Hours and Safety Standards Act and not to any of the other statutes cited in 29 CFR 5.1, the Subrecipient shall insert a clause requiring that the contractor or subcontractor shall maintain payrolls and basic payroll records during the course of the work and shall preserve them for a period of three years from the completion of the contract for all laborers and mechanics, including guards and watchmen, working on the contract. Such records shall contain the name and address of each such employee, social security number, correct classifications, hourly rates of wages paid, daily and weekly number of hours worked, deductions made, and actual wages paid. Further, the Subrecipient shall insert in any such contract a clause providing that the records to be maintained under this paragraph shall be made available by the contractor or subcontractor for inspection, copying, or transcription by authorized representatives of the (write the name of agency) and the Department of Labor, and the contractor or subcontractor will permit such representatives to interview employees during working hours on the job.

## **5. Compliance Verification.**

(a) The subrecipient shall periodically interview a sufficient number of employees entitled to DB prevailing wages (covered employees) to verify that contractors or subcontractors are paying the appropriate wage rates. As provided in 29 CFR 5.6(a)(6), all interviews must be conducted in confidence. The subrecipient must use Standard Form 1445 (SF 1445) or equivalent documentation to memorialize the interviews. Copies of the SF 1445 are available from EPA on request.

(b) The subrecipient shall establish and follow an interview schedule based on its assessment of the risks of noncompliance with DB posed by contractors or subcontractors and the duration of the contract or subcontract. Subrecipients must conduct more frequent interviews if the initial interviews or other information indicates that there is a risk that the contractor or subcontractor is not complying with DB. Subrecipients shall immediately conduct necessary interviews in response to an alleged violation of the prevailing wage requirements. All interviews shall be conducted in confidence.

(c) The subrecipient shall periodically conduct spot checks of a representative sample of weekly payroll data to verify that contractors or subcontractors are paying the appropriate wage rates. The subrecipient shall establish and follow a spot check schedule based on its assessment of the risks of noncompliance with DB posed by contractors or subcontractors and the duration of the contract or subcontract. At a minimum, if practicable, the subrecipient should spot check payroll data within two weeks of each contractor or subcontractor's submission of its initial payroll data and two weeks prior to the completion date the contract or subcontract. Subrecipients must conduct more frequent spot checks if the initial spot check or other information indicates that there is a risk that the contractor or subcontractor is not complying with DB. In addition, during

the examinations the subrecipient shall verify evidence of fringe benefit plans and payments thereunder by contractors and subcontractors who claim credit for fringe benefit contributions.

(d) The subrecipient shall periodically review contractors and subcontractor's use of apprentices and trainees to verify registration and certification with respect to apprenticeship and training programs approved by either the U.S Department of Labor or a state, as appropriate, and that contractors and subcontractors are not using disproportionate numbers of, laborers, trainees and apprentices. These reviews shall be conducted in accordance with the schedules for spot checks and interviews described in Item 5(b) and (c) above.

(e) Subrecipients must immediately report potential violations of the DB prevailing wage requirements to the EPA DB contact listed above and to the appropriate DOL Wage and Hour District Office listed at <http://www.dol.gov/contacts/whd/america2.htm>.

## **II. Requirements Under The Consolidated and further Continuing Appropriations Act, 2013 (P.L. 113-6) For Subrecipients That Are Not Governmental Agencies**

The following terms and conditions specify how recipients will assist EPA in meeting its DB responsibilities when DB applies to EPA awards of financial assistance under the FY2013 Continuing Resolution with respect to subrecipients that are not governmental entities. If a subrecipient has questions regarding when DB applies, obtaining the correct DB wage determinations, DB provisions, or compliance monitoring, it may contact the State recipient for guidance. The recipient or subrecipient may also obtain additional guidance from DOL's web site at <http://www.dol.gov/whd/>.

**Under these terms and conditions, the subrecipient must submit its proposed DB wage determinations to the State recipient for approval prior to including the wage determination in any solicitation, contract task orders, work assignments, or similar instruments to existing contractors.**

### **1. Applicability of the Davis- Bacon (DB) prevailing wage requirements.**

Under the FY 2013 Continuing Resolution, Davis-Bacon prevailing wage requirements apply to the construction, alteration, and repair of treatment works carried out in whole or in part with assistance made available by a State water pollution control revolving fund and to any construction project carried out in whole or in part by assistance made available by a drinking water treatment revolving loan fund. If a subrecipient encounters a unique situation at a site that presents uncertainties regarding DB applicability, the subrecipient must discuss the situation with the recipient State before authorizing work on that site.

### **2. Obtaining Wage Determinations.**

(a) Subrecipients must obtain proposed wage determinations for specific localities at [www.wdol.gov](http://www.wdol.gov). After the Subrecipient obtains its proposed wage determination, it must submit the wage determination to (insert contact information for State recipient DB point of contact for wage determination) for approval prior to inserting the wage determination into a solicitation, contract or issuing task orders, work assignments or similar instruments to existing contractors

(ordering instruments unless subsequently directed otherwise by the State recipient Award Official).

(b) Subrecipients shall obtain the wage determination for the locality in which a covered activity subject to DB will take place prior to issuing requests for bids, proposals, quotes or other methods for soliciting contracts (solicitation) for activities subject to DB. These wage determinations shall be incorporated into solicitations and any subsequent contracts. Prime contracts must contain a provision requiring that subcontractors follow the wage determination incorporated into the prime contract.

(i) While the solicitation remains open, the subrecipient shall monitor [www.wdol.gov](http://www.wdol.gov) on a weekly basis to ensure that the wage determination contained in the solicitation remains current. The subrecipients shall amend the solicitation if DOL issues a modification more than 10 days prior to the closing date (i.e. bid opening) for the solicitation. If DOL modifies or supersedes the applicable wage determination less than 10 days prior to the closing date, the subrecipients may request a finding from the State recipient that there is not a reasonable time to notify interested contractors of the modification of the wage determination. The State recipient will provide a report of its findings to the subrecipient.

(ii) If the subrecipient does not award the contract within 90 days of the closure of the solicitation, any modifications or supersedes DOL makes to the wage determination contained in the solicitation shall be effective unless the State recipient, at the request of the subrecipient, obtains an extension of the 90 day period from DOL pursuant to 29 CFR 1.6(c)(3)(iv). The subrecipient shall monitor [www.wdol.gov](http://www.wdol.gov) on a weekly basis if it does not award the contract within 90 days of closure of the solicitation to ensure that wage determinations contained in the solicitation remain current.

(c) If the subrecipient carries out activity subject to DB by issuing a task order, work assignment or similar instrument to an existing contractor (ordering instrument) rather than by publishing a solicitation, the subrecipient shall insert the appropriate DOL wage determination from [www.wdol.gov](http://www.wdol.gov) into the ordering instrument.

(c) Subrecipients shall review all subcontracts subject to DB entered into by prime contractors to verify that the prime contractor has required its subcontractors to include the applicable wage determinations.

(d) As provided in 29 CFR 1.6(f), DOL may issue a revised wage determination applicable to a subrecipient's contract after the award of a contract or the issuance of an ordering instrument if DOL determines that the subrecipient has failed to incorporate a wage determination or has used a wage determination that clearly does not apply to the contract or ordering instrument. If this occurs, the subrecipient shall either terminate the contract or ordering instrument and issue a revised solicitation or ordering instrument or incorporate DOL's wage determination retroactive to the beginning of the contract or ordering instrument by change order. The subrecipient's contractor must be compensated for any increases in wages resulting from the use of DOL's revised wage determination.

### 3. Contract and Subcontract provisions.

(a) The Recipient shall insure that the subrecipient(s) shall insert in full in any contract in excess of \$2,000 which is entered into for the actual construction, alteration and/or repair, including

painting and decorating, of a treatment work under the CWSRF or a construction project under the DWSRF financed in whole or in part from Federal funds or in accordance with guarantees of a Federal agency or financed from funds obtained by pledge of any contract of a Federal agency to make a loan, grant or annual contribution (except where a different meaning is expressly indicated), and which is subject to the labor standards provisions of any of the acts listed in § 5.1 or the FY 2013 Continuing Resolution, the following clauses:

(1) Minimum wages.

(i) All laborers and mechanics employed or working upon the site of the work, will be paid unconditionally and not less often than once a week, and without subsequent deduction or rebate on any account (except such payroll deductions as are permitted by regulations issued by the Secretary of Labor under the Copeland Act (29 CFR part 3) ), the full amount of wages and bona fide fringe benefits (or cash equivalents thereof) due at time of payment computed at rates not less than those contained in the wage determination of the Secretary of Labor which is attached hereto and made a part hereof, regardless of any contractual relationship which may be alleged to exist between the contractor and such laborers and mechanics.

Contributions made or costs reasonably anticipated for bona fide fringe benefits under section 1(b)(2) of the Davis-Bacon Act on behalf of laborers or mechanics are considered wages paid to such laborers or mechanics, subject to the provisions of paragraph (a)(1)(iv) of this section; also, regular contributions made or costs incurred for more than a weekly period (but not less often than quarterly) under plans, funds, or programs which cover the particular weekly period, are deemed to be constructively made or incurred during such weekly period. Such laborers and mechanics shall be paid the appropriate wage rate and fringe benefits on the wage determination for the classification of work actually performed, without regard to skill, except as provided in § 5.5(a)(4). Laborers or mechanics performing work in more than one classification may be compensated at the rate specified for each classification for the time actually worked therein: Provided, that the employer's payroll records accurately set forth the time spent in each classification in which work is performed. The wage determination (including any additional classification and wage rates conformed under paragraph (a)(1)(ii) of this section) and the Davis-Bacon poster (WH-1321) shall be posted at all times by the contractor and its subcontractors at the site of the work in a prominent and accessible place where it can be easily seen by the workers.

Subrecipients may obtain wage determinations from the U.S. Department of Labor's web site, [www.dol.gov](http://www.dol.gov).

(ii)(A) The subrecipient(s), on behalf of EPA, shall require that any class of laborers or mechanics, including helpers, which is not listed in the wage determination and which is to be employed under the contract shall be classified in conformance with the wage determination. The State award official shall approve a request for an additional classification and wage rate and fringe benefits therefore only when the following criteria have been met:

(1) The work to be performed by the classification requested is not performed by a classification in the wage determination; and

(2) The classification is utilized in the area by the construction industry; and

(3) The proposed wage rate, including any bona fide fringe benefits, bears a reasonable relationship to the wage rates contained in the wage determination.

(B) If the contractor and the laborers and mechanics to be employed in the classification (if known), or their representatives, and the subrecipient(s) agree on the classification and wage rate (including the amount designated for fringe benefits where appropriate), documentation of the action taken and the request, including the local wage determination shall be sent by the subrecipient(s) to the State award official. The State award official will transmit the report, to the Administrator of the Wage and Hour Division, Employment Standards Administration, U.S. Department of Labor, Washington, DC 20210 and to the EPA DB Regional Coordinator concurrently. The Administrator, or an authorized representative, will approve, modify, or disapprove every additional classification request within 30 days of receipt and so advise the State award official or will notify the State award official within the 30-day period that additional time is necessary.

(C) In the event the contractor, the laborers or mechanics to be employed in the classification or their representatives, and the and the subrecipient(s) do not agree on the proposed classification and wage rate (including the amount designated for fringe benefits, where appropriate), the award official shall refer the request, and the local wage determination, including the views of all interested parties and the recommendation of the State award official, to the Administrator for determination. The request shall be sent to the EPA Regional Coordinator concurrently. The Administrator, or an authorized representative, will issue a determination within 30 days of receipt of the request and so advise the contracting officer or will notify the contracting officer within the 30-day period that additional time is necessary.

(D) The wage rate (including fringe benefits where appropriate) determined pursuant to paragraphs (a)(1)(ii)(B) or (C) of this section, shall be paid to all workers performing work in the classification under this contract from the first day on which work is performed in the classification.

(iii) Whenever the minimum wage rate prescribed in the contract for a class of laborers or mechanics includes a fringe benefit which is not expressed as an hourly rate, the contractor shall either pay the benefit as stated in the wage determination or shall pay another bona fide fringe benefit or an hourly cash equivalent thereof.

(iv) If the contractor does not make payments to a trustee or other third person, the contractor may consider as part of the wages of any laborer or mechanic the amount of any costs reasonably anticipated in providing bona fide fringe benefits under a plan or program, Provided, That the Secretary of Labor has found, upon the written request of the contractor, that the applicable standards of the Davis-Bacon Act have been met. The Secretary of Labor may require the contractor to set aside in a separate account assets for the meeting of obligations under the plan or program.

(2) Withholding. The subrecipient(s) shall upon written request of the EPA Award Official or an authorized representative of the Department of Labor, withhold or cause to be withheld from the contractor under this contract or any other Federal contract with the same prime contractor, or any other federally-assisted contract subject to Davis-Bacon prevailing wage requirements, which is held by the same prime contractor, so much of the accrued payments or advances as may be considered necessary to pay laborers and mechanics, including apprentices, trainees, and helpers, employed by the contractor or any subcontractor the full amount of wages required by

the contract. In the event of failure to pay any laborer or mechanic, including any apprentice, trainee, or helper, employed or working on the site of the work, all or part of the wages required by the contract, the (Agency) may, after written notice to the contractor, sponsor, applicant, or owner, take such action as may be necessary to cause the suspension of any further payment, advance, or guarantee of funds until such violations have ceased.

### **(3) Payrolls and basic records.**

(i) Payrolls and basic records relating thereto shall be maintained by the contractor during the course of the work and preserved for a period of three years thereafter for all laborers and mechanics working at the site of the work. Such records shall contain the name, address, and social security number of each such worker, his or her correct classification, hourly rates of wages paid (including rates of contributions or costs anticipated for bona fide fringe benefits or cash equivalents thereof of the types described in section 1(b)(2)(B) of the Davis-Bacon Act), daily and weekly number of hours worked, deductions made and actual wages paid. Whenever the Secretary of Labor has found under 29 CFR 5.5(a)(1)(iv) that the wages of any laborer or mechanic include the amount of any costs reasonably anticipated in providing benefits under a plan or program described in section 1(b)(2)(B) of the Davis-Bacon Act, the contractor shall maintain records which show that the commitment to provide such benefits is enforceable, that the plan or program is financially responsible, and that the plan or program has been communicated in writing to the laborers or mechanics affected, and records which show the costs anticipated or the actual cost incurred in providing such benefits. Contractors employing apprentices or trainees under approved programs shall maintain written evidence of the registration of apprenticeship programs and certification of trainee programs, the registration of the apprentices and trainees, and the ratios and wage rates prescribed in the applicable programs.

(ii)(A) The contractor shall submit weekly, for each week in which any contract work is performed, a copy of all payrolls to the subrecipient, that is, the entity that receives the sub-grant or loan from the State capitalization grant recipient. Such documentation shall be available on request of the State recipient or EPA. As to each payroll copy received, the subrecipient shall provide written confirmation in a form satisfactory to the State indicating whether or not the project is in compliance with the requirements of 29 CFR 5.5(a)(1) based on the most recent payroll copies for the specified week. The payrolls shall set out accurately and completely all of the information required to be maintained under 29 CFR 5.5(a)(3)(i), except that full social security numbers and home addresses shall not be included on the weekly payrolls. Instead the payrolls shall only need to include an individually identifying number for each employee (e.g., the last four digits of the employee's social security number). The required weekly payroll information may be submitted in any form desired. Optional Form WH-347 is available for this purpose from the Wage and Hour Division Web site at <http://www.dol.gov/whd/forms/wh347instr.htm> or its successor site. The prime contractor is responsible for the submission of copies of payrolls by all subcontractors. Contractors and subcontractors shall maintain the full social security number and current address of each covered worker, and shall provide them upon request to the subrecipient(s) for transmission to the State or EPA if requested by EPA, the State, the contractor, or the Wage and Hour Division of the Department of Labor for purposes of an investigation or audit of compliance with prevailing wage requirements. It is not a violation of this section for a prime contractor to require a subcontractor to provide addresses and social security numbers to the prime contractor for its own records, without weekly submission to the subrecipient(s).

(B) Each payroll submitted shall be accompanied by a "Statement of Compliance," signed by the contractor or subcontractor or his or her agent who pays or supervises the payment of the persons employed under the contract and shall certify the following:

(1) That the payroll for the payroll period contains the information required to be provided under § 5.5 (a)(3)(ii) of Regulations, 29 CFR part 5, the appropriate information is being maintained under § 5.5 (a)(3)(i) of Regulations, 29 CFR part 5, and that such information is correct and complete;

(2) That each laborer or mechanic (including each helper, apprentice, and trainee) employed on the contract during the payroll period has been paid the full weekly wages earned, without rebate, either directly or indirectly, and that no deductions have been made either directly or indirectly from the full wages earned, other than permissible deductions as set forth in Regulations, 29 CFR part 3;

(3) That each laborer or mechanic has been paid not less than the applicable wage rates and fringe benefits or cash equivalents for the classification of work performed, as specified in the applicable wage determination incorporated into the contract.

(C) The weekly submission of a properly executed certification set forth on the reverse side of Optional Form WH-347 shall satisfy the requirement for submission of the "Statement of Compliance" required by paragraph (a)(3)(ii)(B) of this section.

(D) The falsification of any of the above certifications may subject the contractor or subcontractor to civil or criminal prosecution under section 1001 of title 18 and section 231 of title 31 of the United States Code.

(iii) The contractor or subcontractor shall make the records required under paragraph (a)(3)(i) of this section available for inspection, copying, or transcription by authorized representatives of the State, EPA or the Department of Labor, and shall permit such representatives to interview employees during working hours on the job. If the contractor or subcontractor fails to submit the required records or to make them available, the Federal agency or State may, after written notice to the contractor, sponsor, applicant, or owner, take such action as may be necessary to cause the suspension of any further payment, advance, or guarantee of funds. Furthermore, failure to submit the required records upon request or to make such records available may be grounds for debarment action pursuant to 29 CFR 5.12.

(4) Apprentices and trainees.

(i) Apprentices. Apprentices will be permitted to work at less than the predetermined rate for the work they performed when they are employed pursuant to and individually registered in a bona fide apprenticeship program registered with the U.S. Department of Labor, Employment and Training Administration, Office of Apprenticeship Training, Employer and Labor Services, or with a State Apprenticeship Agency recognized by the Office, or if a person is employed in his or her first 90 days of probationary employment as an apprentice in such an apprenticeship program, who is not individually registered in the program, but who has been certified by the Office of Apprenticeship Training, Employer and Labor Services or a State Apprenticeship Agency (where appropriate) to be eligible for probationary employment as an apprentice. The allowable ratio of apprentices to journeymen on the job site in any craft classification shall not be greater than the ratio permitted to the contractor as to the entire work force under the registered

program. Any worker listed on a payroll at an apprentice wage rate, who is not registered or otherwise employed as stated above, shall be paid not less than the applicable wage rate on the wage determination for the classification of work actually performed. In addition, any apprentice performing work on the job site in excess of the ratio permitted under the registered program shall be paid not less than the applicable wage rate on the wage determination for the work actually performed. Where a contractor is performing construction on a project in a locality other than that in which its program is registered, the ratios and wage rates (expressed in percentages of the journeyman's hourly rate) specified in the contractor's or subcontractor's registered program shall be observed. Every apprentice must be paid at not less than the rate specified in the registered program for the apprentice's level of progress, expressed as a percentage of the journeymen hourly rate specified in the applicable wage determination. Apprentices shall be paid fringe benefits in accordance with the provisions of the apprenticeship program. If the apprenticeship program does not specify fringe benefits, apprentices must be paid the full amount of fringe benefits listed on the wage determination for the applicable classification. If the Administrator determines that a different practice prevails for the applicable apprentice classification, fringes shall be paid in accordance with that determination. In the event the Office of Apprenticeship Training, Employer and Labor Services, or a State Apprenticeship Agency recognized by the Office, withdraws approval of an apprenticeship program, the contractor will no longer be permitted to utilize apprentices at less than the applicable predetermined rate for the work performed until an acceptable program is approved.

(ii) Trainees. Except as provided in 29 CFR 5.16, trainees will not be permitted to work at less than the predetermined rate for the work performed unless they are employed pursuant to and individually registered in a program which has received prior approval, evidenced by formal certification by the U.S. Department of Labor, Employment and Training Administration. The ratio of trainees to journeymen on the job site shall not be greater than permitted under the plan approved by the Employment and Training Administration. Every trainee must be paid at not less than the rate specified in the approved program for the trainee's level of progress, expressed as a percentage of the journeyman hourly rate specified in the applicable wage determination. Trainees shall be paid fringe benefits in accordance with the provisions of the trainee program. If the trainee program does not mention fringe benefits, trainees shall be paid the full amount of fringe benefits listed on the wage determination unless the Administrator of the Wage and Hour Division determines that there is an apprenticeship program associated with the corresponding journeyman wage rate on the wage determination which provides for less than full fringe benefits for apprentices. Any employee listed on the payroll at a trainee rate who is not registered and participating in a training plan approved by the Employment and Training Administration shall be paid not less than the applicable wage rate on the wage determination for the classification of work actually performed. In addition, any trainee performing work on the job site in excess of the ratio permitted under the registered program shall be paid not less than the applicable wage rate on the wage determination for the work actually performed. In the event the Employment and Training Administration withdraws approval of a training program, the contractor will no longer be permitted to utilize trainees at less than the applicable predetermined rate for the work performed until an acceptable program is approved.

(iii) Equal employment opportunity. The utilization of apprentices, trainees and journeymen under this part shall be in conformity with the equal employment opportunity requirements of Executive Order 11246, as amended, and 29 CFR part 30.

(5) Compliance with Copeland Act requirements. The contractor shall comply with the requirements of 29 CFR part 3, which are incorporated by reference in this contract.



(6) Subcontracts. The contractor or subcontractor shall insert in any subcontracts the clauses contained in 29 CFR 5.5(a)(1) through (10) and such other clauses as the EPA determines may be appropriate, and also a clause requiring the subcontractors to include these clauses in any lower tier subcontracts. The prime contractor shall be responsible for the compliance by any subcontractor or lower tier subcontractor with all the contract clauses in 29 CFR 5.5.

(7) Contract termination: debarment. A breach of the contract clauses in 29 CFR 5.5 may be grounds for termination of the contract, and for debarment as a contractor and a subcontractor as provided in 29 CFR 5.12.

(8) Compliance with Davis-Bacon and Related Act requirements. All rulings and interpretations of the Davis-Bacon and Related Acts contained in 29 CFR parts 1, 3, and 5 are herein incorporated by reference in this contract.

(9) Disputes concerning labor standards. Disputes arising out of the labor standards provisions of this contract shall not be subject to the general disputes clause of this contract. Such disputes shall be resolved in accordance with the procedures of the Department of Labor set forth in 29 CFR parts 5, 6, and 7. Disputes within the meaning of this clause include disputes between the contractor (or any of its subcontractors) and Subrecipient(s), State, EPA, the U.S. Department of Labor, or the employees or their representatives.

(10) Certification of eligibility.

(i) By entering into this contract, the contractor certifies that neither it (nor he or she) nor any person or firm who has an interest in the contractor's firm is a person or firm ineligible to be awarded Government contracts by virtue of section 3(a) of the Davis-Bacon Act or 29 CFR 5.12(a)(1).

(ii) No part of this contract shall be subcontracted to any person or firm ineligible for award of a Government contract by virtue of section 3(a) of the Davis-Bacon Act or 29 CFR 5.12(a)(1).

(iii) The penalty for making false statements is prescribed in the U.S. Criminal Code, 18 U.S.C. 1001.

#### **4. Contract Provision for Contracts in Excess of \$100,000.**

(a) Contract Work Hours and Safety Standards Act. The subrecipient shall insert the following clauses set forth in paragraphs (a)(1), (2), (3), and (4) of this section in full in any contract in an amount in excess of \$100,000 and subject to the overtime provisions of the Contract Work Hours and Safety Standards Act. These clauses shall be inserted in addition to the clauses required by Item 3, above or 29 CFR 4.6. As used in this paragraph, the terms laborers and mechanics include watchmen and guards.

(1) Overtime requirements. No contractor or subcontractor contracting for any part of the contract work which may require or involve the employment of laborers or mechanics shall require or permit any such laborer or mechanic in any workweek in which he or she is employed on such work to work in excess of forty hours in such workweek unless such laborer or mechanic receives compensation at a rate not less than one and one-half times the basic rate of pay for all hours worked in excess of forty hours in such workweek.

(2) Violation; liability for unpaid wages; liquidated damages. In the event of any violation of the clause set forth in paragraph (b)(1) of this section the contractor and any subcontractor responsible therefore shall be liable for the unpaid wages. In addition, such contractor and subcontractor shall be liable to the United States (in the case of work done under contract for the District of Columbia or a territory, to such District or to such territory), for liquidated damages. Such liquidated damages shall be computed with respect to each individual laborer or mechanic, including watchmen and guards, employed in violation of the clause set forth in paragraph (b)(1) of this section, in the sum of \$10 for each calendar day on which such individual was required or permitted to work in excess of the standard workweek of forty hours without payment of the overtime wages required by the clause set forth in paragraph (b)(1) of this section.

(3) Withholding for unpaid wages and liquidated damages. The subrecipient shall upon the request of the EPA Award Official or an authorized representative of the Department of Labor, withhold or cause to be withheld, from any moneys payable on account of work performed by the contractor or subcontractor under any such contract or any other Federal contract with the same prime contractor, or any other federally-assisted contract subject to the Contract Work Hours and Safety Standards Act, which is held by the same prime contractor, such sums as may be determined to be necessary to satisfy any liabilities of such contractor or subcontractor for unpaid wages and liquidated damages as provided in the clause set forth in paragraph (a)(2) of this section.

(4) Subcontracts. The contractor or subcontractor shall insert in any subcontracts the clauses set forth in paragraph (b)(1) through (4) of this section and also a clause requiring the subcontractors to include these clauses in any lower tier subcontracts. The prime contractor shall be responsible for compliance by any subcontractor or lower tier subcontractor with the clauses set forth in paragraphs (b)(1) through (4) of this section.

(c) In addition to the clauses contained in Item 3, above, in any contract subject only to the Contract Work Hours and Safety Standards Act and not to any of the other statutes cited in 29 CFR 5.1, the Subrecipient shall insert a clause requiring that the contractor or subcontractor shall maintain payrolls and basic payroll records during the course of the work and shall preserve them for a period of three years from the completion of the contract for all laborers and mechanics, including guards and watchmen, working on the contract. Such records shall contain the name and address of each such employee, social security number, correct classifications, hourly rates of wages paid, daily and weekly number of hours worked, deductions made, and actual wages paid. Further, the Subrecipient shall insert in any such contract a clause providing that the records to be maintained under this paragraph shall be made available by the contractor or subcontractor for inspection, copying, or transcription by authorized representatives of the (write the name of agency) and the Department of Labor, and the contractor or subcontractor will permit such representatives to interview employees during working hours on the job.

## **5. Compliance Verification.**

(a) The subrecipient shall periodically interview a sufficient number of employees entitled to DB prevailing wages (covered employees) to verify that contractors or subcontractors are paying the appropriate wage rates. As provided in 29 CFR 5.6(a)(6), all interviews must be conducted in confidence. The subrecipient must use Standard Form 1445 (SF 1445) or equivalent documentation to memorialize the interviews. Copies of the SF 1445 are available from EPA on request.

(b) The subrecipient shall establish and follow an interview schedule based on its assessment of the risks of noncompliance with DB posed by contractors or subcontractors and the duration of the contract or subcontract. Subrecipients must conduct more frequent interviews if the initial interviews or other information indicates that there is a risk that the contractor or subcontractor is not complying with DB. Subrecipients shall immediately conduct necessary interviews in response to an alleged violation of the prevailing wage requirements. All interviews shall be conducted in confidence.

(c) The subrecipient shall periodically conduct spot checks of a representative sample of weekly payroll data to verify that contractors or subcontractors are paying the appropriate wage rates. The subrecipient shall establish and follow a spot check schedule based on its assessment of the risks of noncompliance with DB posed by contractors or subcontractors and the duration of the contract or subcontract. At a minimum, if practicable the subrecipient should spot check payroll data within two weeks of each contractor or subcontractor's submission of its initial payroll data and two weeks prior to the completion date the contract or subcontract. Subrecipients must conduct more frequent spot checks if the initial spot check or other information indicates that there is a risk that the contractor or subcontractor is not complying with DB . In addition, during the examinations the subrecipient shall verify evidence of fringe benefit plans and payments thereunder by contractors and subcontractors who claim credit for fringe benefit contributions.

(d) The subrecipient shall periodically review contractors and subcontractors use of apprentices and trainees to verify registration and certification with respect to apprenticeship and training programs approved by either the U.S Department of Labor or a state, as appropriate, and that contractors and subcontractors are not using disproportionate numbers of, laborers, trainees and apprentices. These reviews shall be conducted in accordance with the schedules for spot checks and interviews described in Item 5(b) and (c) above.

(e) Subrecipients must immediately report potential violations of the DB prevailing wage requirements to the EPA DB contact listed above and to the appropriate DOL Wage and Hour District Office listed at <http://www.dol.gov/whd/america2.htm> or its successor site.

**American Iron and Steel Requirement**

The Contractor acknowledges to and for the benefit of the \_\_\_\_\_ (“Purchaser”) and the State of Kentucky (the “State”) that it understands the goods and services under this Agreement are being funded with monies made available by the Clean Water State Revolving Fund and/or Drinking Water State Revolving Fund that have statutory requirements commonly known as “American Iron and Steel;” that requires all of the iron and steel products used in the project to be produced in the United States (“American Iron and Steel Requirement”) including iron and steel products provided by the Contactor pursuant to this Agreement.

The Contractor hereby represents and warrants to and for the benefit of the Purchaser and the State that (a) the Contractor has reviewed and understands the American Iron and Steel Requirement, (b) all of the iron and steel products used in the project will be and/or have been produced in the United States in a manner that complies with the American Iron and Steel Requirement, unless a waiver of the requirement is approved, and (c) the Contractor will provide any further verified information, certification or assurance of compliance with this paragraph, or information necessary to support a waiver of the American Iron and Steel Requirement, as may be requested by the Purchaser or the State. Notwithstanding any other provision of this Agreement, any failure to comply with this paragraph by the Contractor shall permit the Purchaser or State to recover as damages against the Contractor any loss, expense, or cost (including without limitation attorney’s fees) incurred by the Purchaser or State resulting from any such failure (including without limitation any impairment or loss of funding, whether in whole or in part, from the State or any damages owed to the State by the Purchaser).

While the Contractor has no direct contractual privity with the State, as a lender to the Purchaser for the funding of its project, the Purchaser and the Contractor agree that the State is a third-party beneficiary and neither this paragraph (nor any other provision of this Agreement necessary to give this paragraph force or effect) shall be amended or waived without the prior written consent of the State.

## Sample Certification

The following information is provided as a sample letter of step certification for AIS compliance. Documentation must be provided on company letterhead.

Date

Company Name

Company Address

City, State Zip

Subject: American Iron and Steel Step Certification for Project (XXXXXXXXXXXX)

I, (company representative), certify that the (melting, bending, coating, galvanizing, cutting, etc.) process for (manufacturing or fabricating) the following products and/or materials shipped or provided for the subject project is in full compliance with the American Iron and Steel requirement as mandated in EPA's State Revolving Fund Programs.

Item, Products and/or Materials:

1. XXXX
2. XXXX
3. XXXX

Such process took place at the following location:

\_\_\_\_\_

If any of the above compliance statements change while providing material to this project we will immediately notify the prime contractor and the engineer.

Signed by company representative



**SECTION 00815 – GUIDANCE FOR THE IMPLEMENTATION OF AMERICAN IRON AND STEEL PROVISIONS**

(This page intentionally left blank)

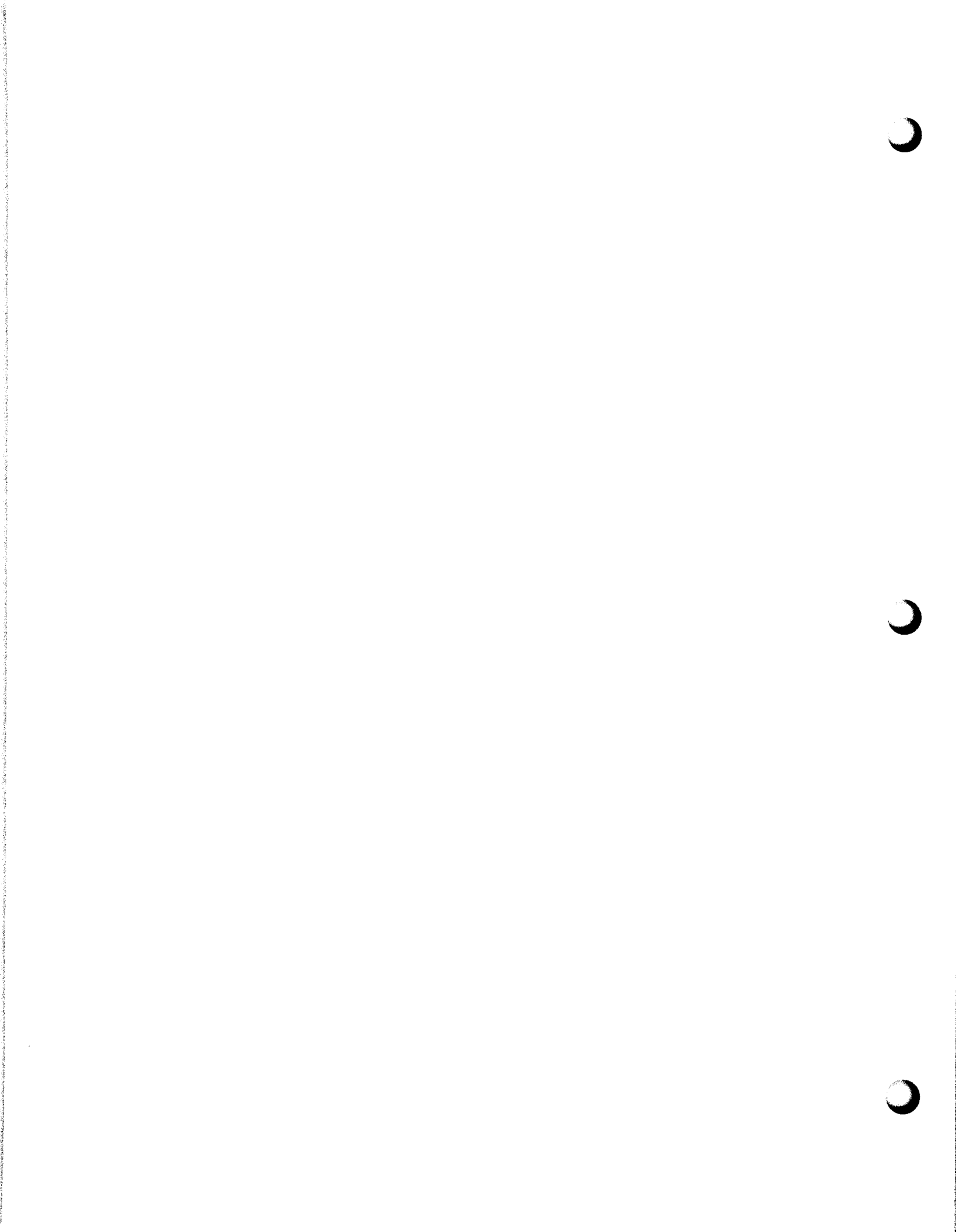





UNITED STATES ENVIRONMENTAL PROTECTION AGENCY  
WASHINGTON, D.C. 20460

MAR 20 2014

OFFICE OF WATER

**MEMORANDUM**

SUBJECT: Implementation of American Iron and Steel provisions of P.L. 113-76,  
Consolidated Appropriations Act, 2014

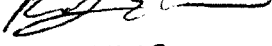
FROM: For Andrew D. Sawyers, Director   
Office of Wastewater Management (4201M)

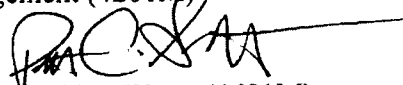
Peter C. Grevatt, Director   
Office of Ground Water and Drinking Water (4601M)

TO: Water Management Division Directors  
Regions I - X

P.L. 113-76, Consolidated Appropriations Act, 2014 (Act), includes an "American Iron and Steel (AIS)" requirement in section 436 that requires Clean Water State Revolving Loan Fund (CWSRF) and Drinking Water State Revolving Loan Fund (DWSRF) assistance recipients to use iron and steel products that are produced in the United States for projects for the construction, alteration, maintenance, or repair of a public water system or treatment works if the project is funded through an assistance agreement executed beginning January 17, 2014 (enactment of the Act), through the end of Federal Fiscal Year 2014.

Section 436 also sets forth certain circumstances under which EPA may waive the AIS requirement. Furthermore, the Act specifically exempts projects where engineering plans and specifications were approved by a State agency prior to January 17, 2014.

The approach described below explains how EPA will implement the AIS requirement. The first section is in the form of questions and answers that address the types of projects that must comply with the AIS requirement, the types of products covered by the AIS requirement, and compliance. The second section is a step-by-step process for requesting waivers and the circumstances under which waivers may be granted.

## Implementation

The Act states:

Sec. 436. (a)(1) None of the funds made available by a State water pollution control revolving fund as authorized by title VI of the Federal Water Pollution Control Act (33 U.S.C. 1381 et seq.) or made available by a drinking water treatment revolving loan fund as authorized by section 1452 of the Safe Drinking Water Act (42 U.S.C. 300j-12) shall be used for a project for the construction, alteration, maintenance, or repair of a public water system or treatment works unless all of the iron and steel products used in the project are produced in the United States.

(2) In this section, the term “iron and steel products” means the following products made primarily of iron or steel: lined or unlined pipes and fittings, manhole covers and other municipal castings, hydrants, tanks, flanges, pipe clamps and restraints, valves, structural steel, reinforced precast concrete, and construction materials.

(b) Subsection (a) shall not apply in any case or category of cases in which the Administrator of the Environmental Protection Agency (in this section referred to as the “Administrator”) finds that—

(1) applying subsection (a) would be inconsistent with the public interest;

(2) iron and steel products are not produced in the United States in sufficient and reasonably available quantities and of a satisfactory quality; or

(3) inclusion of iron and steel products produced in the United States will increase the cost of the overall project by more than 25 percent.

(c) If the Administrator receives a request for a waiver under this section, the Administrator shall make available to the public on an informal basis a copy of the request and information available to the Administrator concerning the request, and shall allow for informal public input on the request for at least 15 days prior to making a finding based on the request. The Administrator shall make the request and accompanying information available by electronic means, including on the official public Internet Web site of the Environmental Protection Agency.

(d) This section shall be applied in a manner consistent with United States obligations under international agreements.

(e) The Administrator may retain up to 0.25 percent of the funds appropriated in this Act for the Clean and Drinking Water State Revolving Funds for carrying out

the provisions described in subsection (a)(1) for management and oversight of the requirements of this section.

(f) This section does not apply with respect to a project if a State agency approves the engineering plans and specifications for the project, in that agency's capacity to approve such plans and specifications prior to a project requesting bids, prior to the date of the enactment of this Act.

The following questions and answers provide guidance for implementing and complying with the AIS requirements:

### **Project Coverage**

#### **1) What classes of projects are covered by the AIS requirement?**

All treatment works projects funded by a CWSRF assistance agreement, and all public water system projects funded by a DWSRF assistance agreement, from the date of enactment through the end of Federal Fiscal Year 2014, are covered. The AIS requirements apply to the entirety of the project, no matter when construction begins or ends. Additionally, the AIS requirements apply to all parts of the project, no matter the source of funding.

#### **2) Does the AIS requirement apply to nonpoint source projects or national estuary projects?**

No. Congress did not include an AIS requirement for nonpoint source and national estuary projects unless the project can also be classified as a 'treatment works' as defined by section 212 of the Clean Water Act.

#### **3) Are any projects for the construction, alteration, maintenance, or repair of a public water system or treatment works excluded from the AIS requirement?**

Any project, whether a treatment works project or a public water system project, for which engineering plans and specifications were approved by the responsible state agency prior to January 17, 2014, is excluded from the AIS requirements.

#### **4) What if the project does not have approved engineering plans and specifications but has signed an assistance agreement with a CWSRF or DWSRF program prior to January 17, 2014?**

The AIS requirements do not apply to any project for which an assistance agreement was signed prior to January 17, 2014.

- 5) What if the project does not have approved engineering plans and specifications, but bids were advertised prior to January 17, 2014 and an assistance agreement was signed after January 17, 2014?**

If the project does not require approved engineering plans and specifications, the bid advertisement date will count in lieu of the approval date for purposes of the exemption in section 436(f).

- 6) What if the assistance agreement that was signed prior to January 17, 2014, only funded a part of the overall project, where the remainder of the project will be funded later with another SRF loan?**

If the original assistance agreement funded any construction of the project, the date of the original assistance agreement counts for purposes of the exemption. If the original assistance agreement was only for planning and design, the date of that assistance agreement will count for purposes of the exemption only if there is a written commitment or expectation on the part of the assistance recipient to fund the remainder of the project with SRF funds.

- 7) What if the assistance agreement that was signed prior to January 17, 2014, funded the first phase of a multi-phase project, where the remaining phases will be funded by SRF assistance in the future?**

In such a case, the phases of the project will be considered a single project if all construction necessary to complete the building or work, regardless of the number of contracts or assistance agreements involved, are closely related in purpose, time and place. However, there are many situations in which major construction activities are clearly undertaken in phases that are distinct in purpose, time, or place. In the case of distinct phases, projects with engineering plans and specifications approval or assistance agreements signed prior to January 17, 2014 would be excluded from AIS requirements while those approved/signed on January 17, 2014, or later would be covered by the AIS requirements.

- 8) What if a project has split funding from a non-SRF source?**

Many States intend to fund projects with "split" funding, from the SRF program and from State or other programs. Based on the Act language in section 436, which requires that American iron and steel products be used in any project for the construction, alteration, maintenance, or repair of a public water system or treatment works receiving SRF funding between and including January 17, 2014 and September 30, 2014, any project that is funded in whole or in part with such funds must comply with the AIS requirement. A "project" consists of all construction necessary to complete the building or work regardless of the number of contracts or assistance agreements involved so long as all contracts and assistance agreements awarded are closely related in purpose, time and place. This precludes the intentional splitting of SRF projects into separate and smaller contracts or assistance agreements to avoid AIS coverage on some portion of a larger

project, particularly where the activities are integrally and proximately related to the whole. However, there are many situations in which major construction activities are clearly undertaken in separate phases that are distinct in purpose, time, or place, in which case, separate contracts or assistance agreement for SRF and State or other funding would carry separate requirements.

**9) What about refinancing?**

If a project began construction, financed from a non-SRF source, prior to January 17, 2014, but is refinanced through an SRF assistance agreement executed on or after January 17, 2014 and prior to October 1, 2014, AIS requirements will apply to all construction that occurs on or after January 17, 2014, through completion of construction, unless, as is likely, engineering plans and specifications were approved by a responsible state agency prior to January 17, 2014. There is no retroactive application of the AIS requirements where a refinancing occurs for a project that has completed construction prior to January 17, 2014.

**10) Do the AIS requirements apply to any other EPA programs, besides the SRF program, such as the Tribal Set-aside grants or grants to the Territories and DC?**

No, the AIS requirement only applies to funds made available by a State water pollution control revolving fund as authorized by title VI of the Federal Water Pollution Control Act (33 U.S.C. 1381 et seq.) or made available by a drinking water treatment revolving loan fund as authorized by section 1452 of the Safe Drinking Water Act (42 U.S.C. 300j-12)

**Covered Iron and Steel Products**

**11) What is an iron or steel product?**

For purposes of the CWSRF and DWSRF projects that must comply with the AIS requirement, an iron or steel product is one of the following made primarily of iron or steel that is permanently incorporated into the public water system or treatment works:

- Lined or unlined pipes or fittings;
- Manhole Covers;
- Municipal Castings (defined in more detail below);
- Hydrants;
- Tanks;
- Flanges;
- Pipe clamps and restraints;
- Valves;
- Structural steel (defined in more detail below);
- Reinforced precast concrete; and
- Construction materials (defined in more detail below).

**12) What does the term 'primarily iron or steel' mean?**

'Primarily iron or steel' places constraints on the list of products above. For one of the listed products to be considered subject to the AIS requirements, it must be made of greater than 50% iron or steel, measured by cost. The cost should be based on the material costs.

**13) Can you provide an example of how to perform a cost determination?**

For example, the iron portion of a fire hydrant would likely be the bonnet, body and shoe, and the cost then would include the pouring and casting to create those components. The other material costs would include non-iron and steel internal workings of the fire hydrant (i.e., stem, coupling, valve, seals, etc). However, the assembly of the internal workings into the hydrant body would not be included in this cost calculation. If one of the listed products is not made primarily of iron or steel, United States (US) provenance is not required. An exception to this definition is reinforced precast concrete, which is addressed in a later question.

**14) If a product is composed of more than 50% iron or steel, but is not listed in the above list of items, must the item be produced in the US? Alternatively, must the iron or steel in such a product be produced in the US?**

The answer to both question is no. Only items on the above list must be produced in the US. Additionally, the iron or steel in a non-listed item can be sourced from outside the US.

**15) What is the definition of steel?**

Steel means an alloy that includes at least 50 percent iron, between .02 and 2 percent carbon, and may include other elements. Metallic elements such as chromium, nickel, molybdenum, manganese, and silicon may be added during the melting of steel for the purpose of enhancing properties such as corrosion resistance, hardness, or strength. The definition of steel covers carbon steel, alloy steel, stainless steel, tool steel and other specialty steels.

**16) What does 'produced in the United States' mean?**

Production in the United States of the iron or steel products used in the project requires that all manufacturing processes, including application of coatings, must take place in the United States, with the exception of metallurgical processes involving refinement of steel additives. All manufacturing processes includes processes such as melting, refining, forming, rolling, drawing, finishing, fabricating and coating. Further, if a domestic iron and steel product is taken out of the US for any part of the manufacturing process, it becomes foreign source material. However, raw materials such as iron ore, limestone and iron and steel scrap are not covered by the AIS requirement, and the

material(s), if any, being applied as a coating are similarly not covered. Non-iron or steel components of an iron and steel product may come from non-US sources. For example, for products such as valves and hydrants, the individual non-iron and steel components do not have to be of domestic origin.

**17) Are the raw materials used in the production of iron or steel required to come from US sources?**

No. Raw materials, such as iron ore, limestone, scrap iron, and scrap steel, can come from non-US sources.

**18) If an above listed item is primarily made of iron or steel, but is only at the construction site temporarily, must such an item be produced in the US?**

No. Only the above listed products made primarily of iron or steel, permanently incorporated into the project must be produced in the US. For example trench boxes, scaffolding or equipment, which are removed from the project site upon completion of the project, are not required to be made of U.S. Iron or Steel.

**19) What is the definition of 'municipal castings'?**

Municipal castings are cast iron or steel infrastructure products that are melted and cast. They typically provide access, protection, or housing for components incorporated into utility owned drinking water, storm water, wastewater, and surface infrastructure. They are typically made of grey or ductile iron, or steel. Examples of municipal castings are:

- Access Hatches;
- Ballast Screen;
- Benches (Iron or Steel);
- Bollards;
- Cast Bases;
- Cast Iron Hinged Hatches, Square and Rectangular;
- Cast Iron Riser Rings;
- Catch Basin Inlet;
- Cleanout/Monument Boxes;
- Construction Covers and Frames;
- Curb and Corner Guards;
- Curb Openings;
- Detectable Warning Plates;
- Downspout Shoes (Boot, Inlet);
- Drainage Grates, Frames and Curb Inlets;
- Inlets;
- Junction Boxes;
- Lampposts;
- Manhole Covers, Rings and Frames, Risers;

Meter Boxes;  
Service Boxes;  
Steel Hinged Hatches, Square and Rectangular;  
Steel Riser Rings;  
Trash receptacles;  
Tree Grates;  
Tree Guards;  
Trench Grates; and  
Valve Boxes, Covers and Risers.

**20) What is 'structural steel'?**

Structural steel is rolled flanged shapes, having at least one dimension of their cross-section three inches or greater, which are used in the construction of bridges, buildings, ships, railroad rolling stock, and for numerous other constructional purposes. Such shapes are designated as wide-flange shapes, standard I-beams, channels, angles, tees and zees. Other shapes include H-piles, sheet piling, tie plates, cross ties, and those for other special purposes.

**21) What is a 'construction material' for purposes of the AIS requirement?**

Construction materials are those articles, materials, or supplies made primarily of iron and steel, that are permanently incorporated into the project, not including mechanical and/or electrical components, equipment and systems. Some of these products may overlap with what is also considered "structural steel". This includes, but is not limited to, the following products: wire rod, bar, angles, concrete reinforcing bar, wire, wire cloth, wire rope and cables, tubing, framing, joists, trusses, fasteners (i.e., nuts and bolts), welding rods, decking, grating, railings, stairs, access ramps, fire escapes, ladders, wall panels, dome structures, roofing, ductwork, surface drains, cable hanging systems, manhole steps, fencing and fence tubing, guardrails, doors, and stationary screens.

**22) What is not considered a 'construction material' for purposes of the AIS requirement?**

Mechanical and electrical components, equipment and systems are not considered construction materials. Mechanical equipment is typically that which has motorized parts and/or is powered by a motor. Electrical equipment is typically any machine powered by electricity and includes components that are part of the electrical distribution system.

The following examples (including their appurtenances necessary for their intended use and operation) are NOT considered construction materials: pumps, motors, gear reducers, drives (including variable frequency drives (VFDs)), electric/pneumatic/manual accessories used to operate valves (such as electric valve actuators), mixers, gates, motorized screens (such as traveling screens), blowers/aeration equipment, compressors, meters, sensors, controls and switches, supervisory control and



data acquisition (SCADA), membrane bioreactor systems, membrane filtration systems, filters, clarifiers and clarifier mechanisms, rakes, grinders, disinfection systems, presses (including belt presses), conveyors, cranes, HVAC (excluding ductwork), water heaters, heat exchangers, generators, cabinetry and housings (such as electrical boxes/enclosures), lighting fixtures, electrical conduit, emergency life systems, metal office furniture, shelving, laboratory equipment, analytical instrumentation, and dewatering equipment.

**23) If the iron or steel is produced in the US, may other steps in the manufacturing process take place outside of the US, such as assembly?**

No. Production in the US of the iron or steel used in a listed product requires that all manufacturing processes must take place in the United States, except metallurgical processes involving refinement of steel additives.

**24) What processes must occur in the US to be compliant with the AIS requirement for reinforced precast concrete?**

While reinforced precast concrete may not be at least 50% iron or steel, in this particular case, the reinforcing bar and wire must be produced in the US and meet the same standards as for any other iron or steel product. Additionally, the casting of the concrete product must take place in the US. The cement and other raw materials used in concrete production are not required to be of domestic origin.

If the reinforced concrete is cast at the construction site, the reinforcing bar and wire are considered to be a construction material and must be produced in the US.

**Compliance**

**25) How should an assistance recipient document compliance with the AIS requirement?**

In order to ensure compliance with the AIS requirement, specific AIS contract language must be included in each contract, starting with the assistance agreement, all the way down to the purchase agreements. Sample language for assistance agreements and contracts can be found in Appendix 3 and 4.

EPA recommends the use of a step certification process, similar to one used by the Federal Highway Administration. The step certification process is a method to ensure that producers adhere to the AIS requirement and assistance recipients can verify that products comply with the AIS requirement. The process also establishes accountability and better enables States to take enforcement actions against violators.

Step certification creates a paper trail which documents the location of the manufacturing process involved with the production of steel and iron materials. A step certification is a process under which each handler (supplier, fabricator, manufacturer,

processor, etc) of the iron and steel products certifies that their step in the process was domestically performed. Each time a step in the manufacturing process takes place, the manufacturer delivers its work along with a certification of its origin. A certification can be quite simple. Typically, it includes the name of the manufacturer, the location of the manufacturing facility where the product or process took place (not its headquarters), a description of the product or item being delivered, and a signature by a manufacturer's responsible party. Attached, as Appendix 5, are sample certifications. These certifications should be collected and maintained by assistance recipients.

Alternatively, the final manufacturer that delivers the iron or steel product to the worksite, vendor, or contractor, may provide a certification asserting that all manufacturing processes occurred in the US. While this type of certification may be acceptable, it may not provide the same degree of assurance. Additional documentation may be needed if the certification is lacking important information. Step certification is the best practice.

**26) How should a State ensure assistance recipients are complying with the AIS requirement?**

In order to ensure compliance with the AIS requirement, States SRF programs must include specific AIS contract language in the assistance agreement. Sample language for assistance agreements can be found in Appendix 3.

States should also, as a best practice, conduct site visits of projects during construction and review documentation demonstrating proof of compliance which the assistance recipient has gathered.

**27) What happens if a State or EPA finds a non-compliant iron and/or steel product permanently incorporated in the project?**

If a potentially non-compliant product is identified, the State should notify the assistance recipient of the apparent unauthorized use of the non-domestic component, including a proposed corrective action, and should be given the opportunity to reply. If unauthorized use is confirmed, the State can take one or more of the following actions: request a waiver where appropriate; require the removal of the non-domestic item; or withhold payment for all or part of the project. Only EPA can issue waivers to authorize the use of a non-domestic item. EPA may use remedies available to it under the Clean Water Act, the Safe Drinking Water Act, and 40 CFR part 31 grant regulations, in the event of a violation of a grant term and condition.

It is recommended that the State work collaboratively with EPA to determine the appropriate corrective action, especially in cases where the State is the one who identifies the item in noncompliance or there is a disagreement with the assistance recipient.

If fraud, waste, abuse, or any violation of the law is suspected, the Office of Inspector General (OIG) should be contacted immediately. The OIG can be reached at 1-

888-546-8740 or [OIG\\_Hotline@epa.gov](mailto:OIG_Hotline@epa.gov). More information can be found at this website: <http://www.epa.gov/oig/hotline.htm>.

**28) How do international trade agreements affect the implementation of the AIS requirements?**

The AIS provision applies in a manner consistent with United States obligations under international agreements. Typically, these obligations only apply to direct procurement by the entities that are signatories to such agreements. In general, SRF assistance recipients are not signatories to such agreements, so these agreements have no impact on this AIS provision. In the few instances where such an agreement applies to a municipality, that municipality is under the obligation to determine its applicability and requirements and document the actions taken to comply for the State.

**Waiver Process**

The statute permits EPA to issue waivers for a case or category of cases where EPA finds (1) that applying these requirements would be inconsistent with the public interest; (2) iron and steel products are not produced in the US in sufficient and reasonably available quantities and of a satisfactory quality; or (3) inclusion of iron and steel products produced in the US will increase the cost of the overall project by more than 25 percent.

In order to implement the AIS requirements, EPA has developed an approach to allow for effective and efficient implementation of the waiver process to allow projects to proceed in a timely manner. The framework described below will allow States, on behalf of the assistance recipients, to apply for waivers of the AIS requirement directly to EPA Headquarters. Only waiver requests received from states will be considered. Pursuant to the Act, EPA has the responsibility to make findings as to the issuance of waivers to the AIS requirements.

**Definitions**

The following terms are critical to the interpretation and implementation of the AIS requirements and apply to the process described in this memorandum:

**Reasonably Available Quantity:** The quantity of iron or steel products is available or will be available at the time needed and place needed, and in the proper form or specification as specified in the project plans and design.

**Satisfactory Quality:** The quality of iron or steel products, as specified in the project plans and designs.

**Assistance Recipient:** A borrower or grantee that receives funding from a State CWSRF or DWSRF program.

## Step-By-Step Waiver Process

### Application by Assistance Recipient

Each local entity that receives SRF water infrastructure financial assistance is required by section 436 of the Act to use American made iron and steel products in the construction of its project. However, the recipient may request a waiver. Until a waiver is granted by EPA, the AIS requirement stands, except as noted above with respect to municipalities covered by international agreements.

The waiver process begins with the SRF assistance recipient. In order to fulfill the AIS requirement, the assistance recipient must in good faith design the project (where applicable) and solicit bids for construction with American made iron and steel products. It is essential that the assistance recipient include the AIS terms in any request for proposals or solicitations for bids, and in all contracts (see Appendix 3 for sample construction contract language). The assistance recipient may receive a waiver at any point before, during, or after the bid process, if one or more of three conditions is met:

1. Applying the American Iron and Steel requirements of the Act would be inconsistent with the public interest;
2. Iron and steel products are not produced in the United States in sufficient and reasonably available quantities and of a satisfactory quality; or
3. Inclusion of iron and steel products produced in the United States will increase the cost of the overall project by more than 25 percent.

Proper and sufficient documentation must be provided by the assistance recipient. A checklist detailing the types of information required for a waiver to be processed is attached as Appendix 1.

Additionally, it is strongly encouraged that assistance recipients hold pre-bid conferences with potential bidders. A pre-bid conference can help to identify iron and steel products needed to complete the project as described in the plans and specifications that may not be available from domestic sources. It may also identify the need to seek a waiver prior to bid, and can help inform the recipient on compliance options.

In order to apply for a project waiver, the assistance recipient should email the request in the form of a Word document (.doc) to the State SRF program. It is strongly recommended that the State designate a single person for all AIS communications. The State SRF designee will review the application for the waiver and determine whether the necessary information has been included. Once the waiver application is complete, the State designee will forward the application to either of two email addresses. For CWSRF waiver requests, please send the application to: [cwsrfwaiver@epa.gov](mailto:cwsrfwaiver@epa.gov). For DWSRF waiver requests, please send the application to: [dwsrfwaiver@epa.gov](mailto:dwsrfwaiver@epa.gov).

## Evaluation by EPA

After receiving an application for waiver of the AIS requirements, EPA Headquarters will publish the request on its website for 15 days and receive informal comment. EPA Headquarters will then use the checklist in Appendix 2 to determine whether the application properly and adequately documents and justifies the statutory basis cited for the waiver – that it is quantitatively and qualitatively sufficient – and to determine whether or not to grant the waiver.

In the event that EPA finds that adequate documentation and justification has been submitted, the Administrator may grant a waiver to the assistance recipient. EPA will notify the State designee that a waiver request has been approved or denied as soon as such a decision has been made. Granting such a waiver is a three-step process:

1. Posting – After receiving an application for a waiver, EPA is required to publish the application and all material submitted with the application on EPA's website for 15 days. During that period, the public will have the opportunity to review the request and provide informal comment to EPA. The website can be found at: [http://water.epa.gov/grants\\_funding/aisrequirement.cfm](http://water.epa.gov/grants_funding/aisrequirement.cfm)
2. Evaluation – After receiving an application for waiver of the AIS requirements, EPA Headquarters will use the checklist in Appendix 2 to determine whether the application properly and adequately documents and justifies the statutory basis cited for the waiver – that it is quantitatively and qualitatively sufficient – and to determine whether or not to grant the waiver.
3. Signature of waiver approval by the Administrator or another agency official with delegated authority – As soon as the waiver is signed and dated, EPA will notify the State SRF program, and post the signed waiver on our website. The assistance recipient should keep a copy of the signed waiver in its project files.

## Public Interest Waivers

EPA has the authority to issue public interest waivers. Evaluation of a public interest waiver request may be more complicated than that of other waiver requests so they may take more time than other waiver requests for a decision to be made. An example of a public interest waiver that might be issued could be for a community that has standardized on a particular type or manufacturer of a valve because of its performance to meet their specifications. Switching to an alternative valve may require staff to be trained on the new equipment and additional spare parts would need to be purchased and stocked, existing valves may need to be unnecessarily replaced, and portions of the system may need to be redesigned. Therefore, requiring the community to install an alternative valve would be inconsistent with public interest.

EPA also has the authority to issue a public interest waiver that covers categories of products that might apply to all projects.

EPA reserves the right to issue national waivers that may apply to particular classes of assistance recipients, particular classes of projects, or particular categories of iron or steel products. EPA may develop national or (US geographic) regional categorical waivers through the identification of similar circumstances in the detailed justifications presented to EPA in a waiver request or requests. EPA may issue a national waiver based on policy decisions regarding the public's interest or a determination that a particular item is not produced domestically in reasonably available quantities or of a sufficient quality. In such cases, EPA may determine it is necessary to issue a national waiver.

If you have any questions concerning the contents of this memorandum, you may contact us, or have your staff contact Jordan Dorfman, Attorney-Advisor, State Revolving Fund Branch, Municipal Support Division, at [dorfman.jordan@epa.gov](mailto:dorfman.jordan@epa.gov) or (202) 564-0614 or Kiri Anderer, Environmental Engineer, Infrastructure Branch, Drinking Water Protection Division, at [anderer.kirsten@epa.gov](mailto:anderer.kirsten@epa.gov) or (202) 564-3134.

Attachments

## Appendix 1: Information Checklist for Waiver Request

The purpose of this checklist is to help ensure that all appropriate and necessary information is submitted to EPA. EPA recommends that States review this checklist carefully and provide all appropriate information to EPA. This checklist is for informational purposes only and does not need to be included as part of a waiver application.

Items	✓	Notes
<p><b>General</b></p> <ul style="list-style-type: none"> <li>• Waiver request includes the following information:               <ul style="list-style-type: none"> <li>— Description of the foreign and domestic construction materials</li> <li>— Unit of measure</li> <li>— Quantity</li> <li>— Price</li> <li>— Time of delivery or availability</li> <li>— Location of the construction project</li> <li>— Name and address of the proposed supplier</li> <li>— A detailed justification for the use of foreign construction materials</li> </ul> </li> <li>• Waiver request was submitted according to the instructions in the memorandum</li> <li>• Assistance recipient made a good faith effort to solicit bids for domestic iron and steel products, as demonstrated by language in requests for proposals, contracts, and communications with the prime contractor</li> </ul>	✓	
<p><b>Cost Waiver Requests</b></p> <ul style="list-style-type: none"> <li>• Waiver request includes the following information:               <ul style="list-style-type: none"> <li>— Comparison of overall cost of project with domestic iron and steel products to overall cost of project with foreign iron and steel products</li> <li>— Relevant excerpts from the bid documents used by the contractors to complete the comparison</li> <li>— Supporting documentation indicating that the contractor made a reasonable survey of the market, such as a description of the process for identifying suppliers and a list of contacted suppliers</li> </ul> </li> </ul>		
<p><b>Availability Waiver Requests</b></p> <ul style="list-style-type: none"> <li>• Waiver request includes the following supporting documentation necessary to demonstrate the availability, quantity, and/or quality of the materials for which the waiver is requested:               <ul style="list-style-type: none"> <li>— Supplier information or pricing information from a reasonable number of domestic suppliers indicating availability/delivery date for construction materials</li> <li>— Documentation of the assistance recipient's efforts to find available domestic sources, such as a description of the process for identifying suppliers and a list of contacted suppliers.</li> <li>— Project schedule</li> <li>— Relevant excerpts from project plans, specifications, and permits indicating the required quantity and quality of construction materials</li> </ul> </li> <li>• Waiver request includes a statement from the prime contractor and/or supplier confirming the non-availability of the domestic construction materials for which the waiver is sought</li> <li>• Has the State received other waiver requests for the materials described in this waiver request, for comparable projects?</li> </ul>		

## Appendix 2: HQ Review Checklist for Waiver Request

Instructions: To be completed by EPA. Review all waiver requests using the questions in the checklist, and mark the appropriate box as Yes, No or N/A. Marks that fall inside the shaded boxes may be grounds for denying the waiver. If none of your review markings fall into a shaded box, the waiver is eligible for approval if it indicates that one or more of the following conditions applies to the domestic product for which the waiver is sought:

1. The iron and/or steel products are not produced in the United States in sufficient and reasonably available quantities and of a satisfactory quality.
2. The inclusion of iron and/or steel products produced in the United States will increase the cost of the overall project by more than 25 percent.

Review Items	Yes	No	N/A	Comments
<b>Cost Waiver Requests</b> <ul style="list-style-type: none"> <li>• Does the waiver request include the following information?                             <ul style="list-style-type: none"> <li>— Comparison of overall cost of project with domestic iron and steel products to overall cost of project with foreign iron and steel products</li> <li>— Relevant excerpts from the bid documents used by the contractors to complete the comparison</li> <li>— A sufficient number of bid documents or pricing information from domestic sources to constitute a reasonable survey of the market</li> </ul> </li> <li>• Does the Total Domestic Project exceed the Total Foreign Project Cost by more than 25%?</li> </ul>				
<b>Availability Waiver Requests</b> <ul style="list-style-type: none"> <li>• Does the waiver request include supporting documentation sufficient to show the availability, quantity, and/or quality of the iron and/or steel product for which the waiver is requested?                             <ul style="list-style-type: none"> <li>— Supplier information or other documentation indicating availability/delivery date for materials</li> <li>— Project schedule</li> <li>— Relevant excerpts from project plans, specifications, and permits indicating the required quantity and quality of materials</li> </ul> </li> <li>• Does supporting documentation provide sufficient evidence that the contractors made a reasonable effort to locate domestic suppliers of materials, such as a description of the process for identifying suppliers and a list of contacted suppliers?</li> <li>• Based on the materials delivery/availability date indicated in the supporting documentation, will the materials be unavailable when they are needed according to the project schedule? (By item, list schedule date and domestic delivery quote date or other relevant information)</li> <li>• Is EPA aware of any other evidence indicating the non-availability of the materials for which the waiver is requested?                             <p>Examples include:</p> <ul style="list-style-type: none"> <li>— Multiple waiver requests for the materials described in this waiver request, for comparable projects in the same State</li> <li>— Multiple waiver requests for the materials described in this waiver request, for comparable projects in other States</li> <li>— Correspondence with construction trade associations indicating the non-availability of the materials</li> </ul> </li> <li>• Are the available domestic materials indicated in the bid documents of inadequate quality compared those required by the project plans, specifications, and/or permits?</li> </ul>				



### Appendix 3: Example Loan Agreement Language

ALL ASSISTANCE AGREEMENT MUST HAVE A CLAUSE REQUIRING COMPLIANCE WITH THE AIS REQUIREMENT. THIS IS AN EXAMPLE OF WHAT COULD BE INCLUDED IN SRF ASSISTANCE AGREEMENTS. EPA MAKES NO CLAIMS REGARDING THE LEGALITY OF THIS CLAUSE WITH RESPECT TO STATE LAW:

Comply with all federal requirements applicable to the Loan (including those imposed by the 2014 Appropriations Act and related SRF Policy Guidelines) which the Participant understands includes, among other, requirements that all of the iron and steel products used in the Project are to be produced in the United States (“American Iron and Steel Requirement”) unless (i) the Participant has requested and obtained a waiver from the Agency pertaining to the Project or (ii) the Finance Authority has otherwise advised the Participant in writing that the American Iron and Steel Requirement is not applicable to the Project.

Comply with all record keeping and reporting requirements under the Clean Water Act/Safe Drinking Water Act, including any reports required by a Federal agency or the Finance Authority such as performance indicators of program deliverables, information on costs and project progress. The Participant understands that (i) each contract and subcontract related to the Project is subject to audit by appropriate federal and state entities and (ii) failure to comply with the Clean Water Act/Safe Drinking Water Act and this Agreement may be a default hereunder that results in a repayment of the Loan in advance of the maturity of the Bonds and/or other remedial actions.

#### Appendix 4: Sample Construction Contract Language

ALL CONTRACTS MUST HAVE A CLAUSE REQUIRING COMPLIANCE WITH THE AIS REQUIREMENT. THIS IS AN EXAMPLE OF WHAT COULD BE INCLUDED IN ALL CONTRACTS IN PROJECTS THAT USE SRF FUNDS. EPA MAKES NO CLAIMS REGARDING THE LEGALITY OF THIS CLAUSE WITH RESPECT TO STATE OR LOCAL LAW:

The Contractor acknowledges to and for the benefit of the City of \_\_\_\_\_ (“Purchaser”) and the \_\_\_\_\_ (the “State”) that it understands the goods and services under this Agreement are being funded with monies made available by the Clean Water State Revolving Fund and/or Drinking Water State Revolving Fund that have statutory requirements commonly known as “American Iron and Steel;” that requires all of the iron and steel products used in the project to be produced in the United States (“American Iron and Steel Requirement”) including iron and steel products provided by the Contractor pursuant to this Agreement. The Contractor hereby represents and warrants to and for the benefit of the Purchaser and the State that (a) the Contractor has reviewed and understands the American Iron and Steel Requirement, (b) all of the iron and steel products used in the project will be and/or have been produced in the United States in a manner that complies with the American Iron and Steel Requirement, unless a waiver of the requirement is approved, and (c) the Contractor will provide any further verified information, certification or assurance of compliance with this paragraph, or information necessary to support a waiver of the American Iron and Steel Requirement, as may be requested by the Purchaser or the State. Notwithstanding any other provision of this Agreement, any failure to comply with this paragraph by the Contractor shall permit the Purchaser or State to recover as damages against the Contractor any loss, expense, or cost (including without limitation attorney’s fees) incurred by the Purchaser or State resulting from any such failure (including without limitation any impairment or loss of funding, whether in whole or in part, from the State or any damages owed to the State by the Purchaser). While the Contractor has no direct contractual privity with the State, as a lender to the Purchaser for the funding of its project, the Purchaser and the Contractor agree that the State is a third-party beneficiary and neither this paragraph (nor any other provision of this Agreement necessary to give this paragraph force or effect) shall be amended or waived without the prior written consent of the State.

## Appendix 5: Sample Certifications

The following information is provided as a sample letter of **step** certification for AIS compliance. Documentation must be provided on company letterhead.

Date

Company Name

Company Address

City, State Zip

Subject: American Iron and Steel Step Certification for Project (XXXXXXXXXX)

I, (company representative), certify that the (melting, bending, coating, galvanizing, cutting, etc.) process for (manufacturing or fabricating) the following products and/or materials shipped or provided for the subject project is in full compliance with the American Iron and Steel requirement as mandated in EPA's State Revolving Fund Programs.

Item, Products and/or Materials:

1. Xxxx
2. Xxxx
3. Xxxx

Such process took place at the following location:

\_\_\_\_\_

If any of the above compliance statements change while providing material to this project we will immediately notify the prime contractor and the engineer.

Signed by company representative

The following information is provided as a sample letter of certification for AIS compliance. Documentation must be provided on company letterhead.

Date

Company Name

Company Address

City, State Zip

Subject: American Iron and Steel Certification for Project (XXXXXXXXXX)

I, (company representative), certify that the following products and/or materials shipped/provided to the subject project are in full compliance with the American Iron and Steel requirement as mandated in EPA's State Revolving Fund Programs.

Item, Products and/or Materials:

1. Xxxx
2. Xxxx
3. Xxxx

Such process took place at the following location:

\_\_\_\_\_

If any of the above compliance statements change while providing material to this project we will immediately notify the prime contractor and the engineer.

Signed by company representative

## SECTION 00820 – WAGE DETERMINATION SCHEDULE

### PART 1 – GENERAL

#### 1.01 GENERAL REQUIREMENTS

- A. This Contract shall be based upon payment by the Contractor and his Subcontractors of wage rates not less than the prevailing hourly wage rate for each craft or type of workman engaged on the Work as determined by the US Department of Labor and the Davis-Bacon and Related Acts (DBRA).
- B. The Contractor and each Subcontractor shall keep accurate records indicating the hours worked each day by each employee in each classification of work and the amount paid each employee for his work in each classification. Such records shall be submitted weekly to the contracting agency.
- D. The Contractor and each Subcontractor shall post and keep posted in a conspicuous place or places at the construction site a copy or copies of federal prevailing rates of wages and working hours as prescribed in these Contract Documents.
- E. If, during the life of this Contract, the prevailing hourly rate of wages is changed by the US Department of Labor, such change shall not be the basis of any claim by the Contractor against the Owner, nor will deductions be made by the Owner against sums due the Contractor by reason of any such change.
- F. The federal prevailing wage law does not prohibit payment of more than the prevailing rate of wages.
- G. Pursuant to Kentucky Revised Statute 337.510, no laborer, workman, mechanic, helper, assistant, or apprentice shall be permitted to work more than 8 hours in one calendar day, nor more than 40 hours in one week, except in cases of emergency caused by fire, flood, or damage to life or property. Whenever work in excess of 8 hours per day or 40 hours per week is required, payment of overtime shall be at not less than one and one-half times the prevailing rate of wages.

#### 1.02 PREVAILING WAGE REQUIREMENTS

- A. Wage rates applicable to this project are included in the following pages, or will be issued by an addendum prior to the bid opening.

END OF SECTION

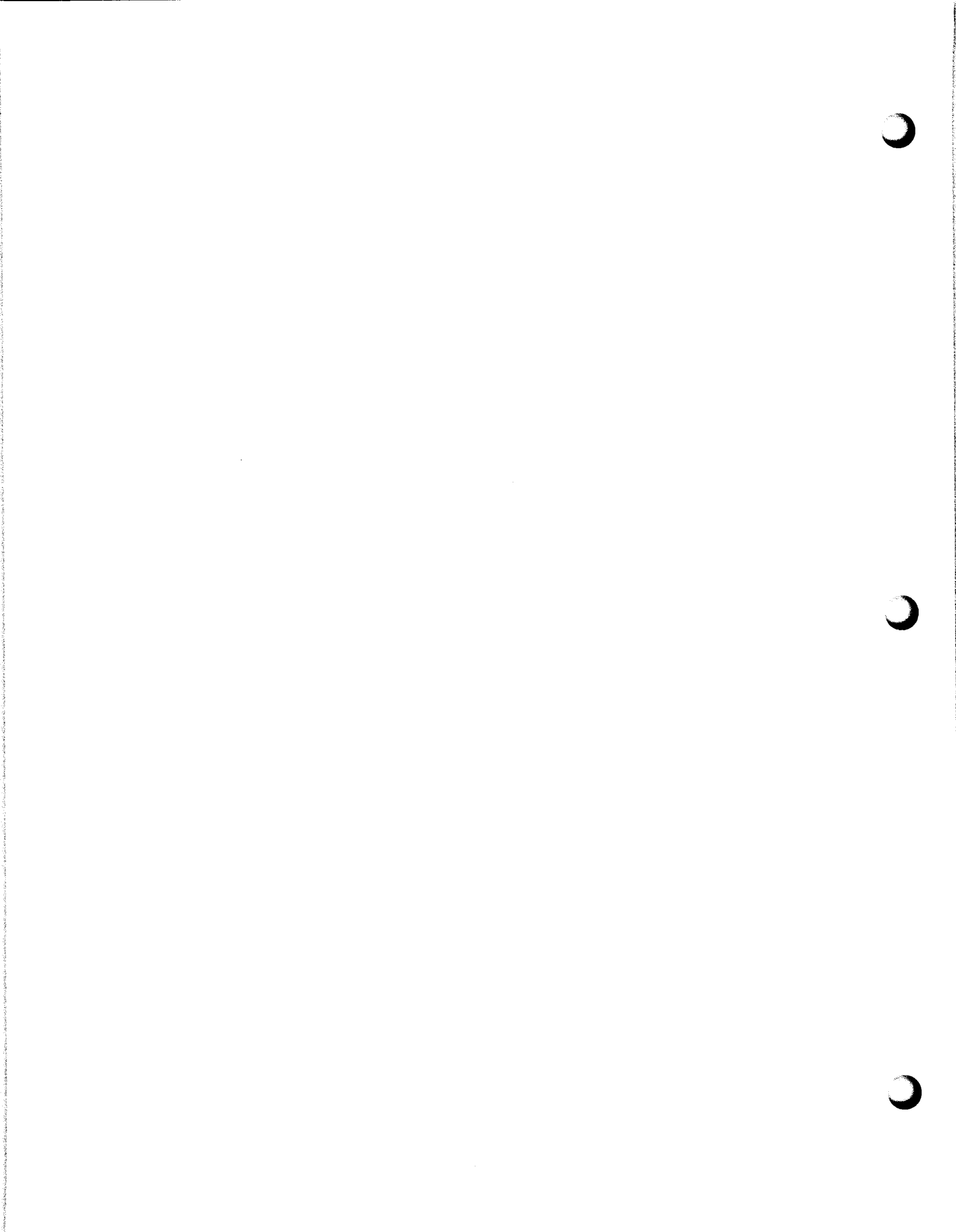

Addendum No. 6

General Decision Number: KY170161 08/11/2017 KY161

Superseded General Decision Number: KY20160161

State: Kentucky

Construction Type: Heavy

Counties: Bourbon, Clark, Fayette, Jessamine, Scott and Woodford Counties in Kentucky.

HEAVY CONSTRUCTION PROJECTS (including sewer/water construction).

Note: Under Executive Order (EO) 13658, an hourly minimum wage of \$10.20 for calendar year 2017 applies to all contracts subject to the Davis-Bacon Act for which the contract is awarded (and any solicitation was issued) on or after January 1, 2015. If this contract is covered by the EO, the contractor must pay all workers in any classification listed on this wage determination at least \$10.20 (or the applicable wage rate listed on this wage determination, if it is higher) for all hours spent performing on the contract in calendar year 2017. The EO minimum wage rate will be adjusted annually. Additional information on contractor requirements and worker protections under the EO is available at [www.dol.gov/whd/govcontracts](http://www.dol.gov/whd/govcontracts).

Modification Number	Publication Date
0	01/06/2017
1	02/24/2017
2	07/14/2017
3	08/04/2017
4	08/11/2017

ELEC0369-004 09/05/2016

	Rates	Fringes
LINE CONSTRUCTION		
Equipment Operator.....	\$ 32.27	20%+5.46
Groundman.....	\$ 21.29	20%+5.46
Lineman.....	\$ 36.12	20%+5.46

ELEC0369-008 06/01/2016

	Rates	Fringes
ELECTRICIAN.....	\$ 30.56	16.10

ENGI0181-016 07/01/2016

	Rates	Fringes
POWER EQUIPMENT OPERATOR		
GROUP 1.....	\$ 31.05	14.65

OPERATING ENGINEER CLASSIFICATIONS

GROUP 1 - Crane; Forklift

Operators on cranes with boom 150 feet and over, including jib, shall receive \$0.75 above Group 1. All cranes with piling leads will receive \$0.50 above Group 1 rate regardless of boom length. Combination rate shall mean \$0.50 per hour above the basic hourly rate of pay.

Employees assigned to work below ground level are to be paid 10% above basic wage rate. This does not apply to open cut work.

-----  
 ENGI0181-051 07/01/2016

	Rates	Fringes
POWER EQUIPMENT OPERATOR		
GROUP 1.....	\$ 31.05	14.65
GROUP 2.....	\$ 28.28	14.65
GROUP 4.....	\$ 27.97	14.65

OPERATING ENGINEER CLASSIFICATIONS

GROUP 1 - Drill; Pumpcrete; Roller (Bituminous)

GROUP 2 - Bobcat/Skid Steer/Skid Loader; Concrete Pump; Roller (Rock)

GROUP 4 - Pump; Roller (Earth)

Operators on cranes with booms 150 feet and over (including jib) shall receive \$1.00 above Group 1 rate; 250 feet and over including jib shall receive \$1.50 above Class 1 rate. Combination Rate: All crane operators operating cranes, where the length of the boom in combination with the length of the piling leads equal or exceeds 150 feet, shall receive \$1.00 above the Group 1 rate.

Employees assigned to work below ground level are to be paid 10% above basic wage rate. This does not apply to open cut work.

-----  
 IRON0044-005 06/01/2017

	Rates	Fringes
IRONWORKER (STRUCTURAL AND REINFORCING).....	\$ 27.60	20.10

\* IRON0070-011 06/01/2017

	Rates	Fringes
IRONWORKER, ORNAMENTAL.....	\$ 28.30	21.85

-----  
 LABO0189-020 07/01/2015



	Rates	Fringes
LABORER		
Concrete Worker.....	\$ 22.30	12.46
-----		
LABO0265-014 05/01/2015		

	Rates	Fringes
LABORER		
Concrete Saw (Hand		
Held/Walk Behind).....	\$ 28.89	9.85
Flagger.....	\$ 28.72	9.85
-----		
SUKY2011-038 06/25/2014		

	Rates	Fringes
CARPENTER (Form Work Only).....	\$ 24.80	8.76
LABORER: Common or General.....	\$ 22.17	9.64
LABORER: Concrete Finishing.....	\$ 25.75	8.60
LABORER: Pipelayer.....	\$ 19.66	10.85
OPERATOR:		
Backhoe/Excavator/Trackhoe.....	\$ 22.56	12.10
OPERATOR: Bulldozer.....	\$ 27.90	13.00
OPERATOR: Loader.....	\$ 26.68	13.00
OPERATOR: Mechanic.....	\$ 28.60	11.83
OPERATOR: Oiler.....	\$ 24.34	13.00
OPERATOR: Trencher.....	\$ 26.27	12.37
TRUCK DRIVER: Dump Truck.....	\$ 17.82	3.26
-----		

WELDERS - Receive rate prescribed for craft performing operation to which welding is incidental.

=====

Note: Executive Order (EO) 13706, Establishing Paid Sick Leave for Federal Contractors applies to all contracts subject to the Davis-Bacon Act for which the contract is awarded (and any solicitation was issued) on or after January 1, 2017. If this contract is covered by the EO, the contractor must provide employees with 1 hour of paid sick leave for every 30 hours they work, up to 56 hours of paid sick leave each year. Employees must be permitted to use paid sick leave for their own illness, injury or other health-related needs, including preventive care; to assist a family member (or person who is like family to the employee) who is ill, injured, or has other health-related needs, including preventive care; or for reasons resulting from, or to assist a family member (or person who is

like family to the employee) who is a victim of, domestic violence, sexual assault, or stalking. Additional information on contractor requirements and worker protections under the EO is available at [www.dol.gov/whd/govcontracts](http://www.dol.gov/whd/govcontracts).

Unlisted classifications needed for work not included within the scope of the classifications listed may be added after award only as provided in the labor standards contract clauses (29CFR 5.5 (a) (1) (ii)).

---

The body of each wage determination lists the classification and wage rates that have been found to be prevailing for the cited type(s) of construction in the area covered by the wage determination. The classifications are listed in alphabetical order of "identifiers" that indicate whether the particular rate is a union rate (current union negotiated rate for local), a survey rate (weighted average rate) or a union average rate (weighted union average rate).

#### Union Rate Identifiers

A four letter classification abbreviation identifier enclosed in dotted lines beginning with characters other than "SU" or "UAVG" denotes that the union classification and rate were prevailing for that classification in the survey. Example: PLUM0198-005 07/01/2014. PLUM is an abbreviation identifier of the union which prevailed in the survey for this classification, which in this example would be Plumbers. 0198 indicates the local union number or district council number where applicable, i.e., Plumbers Local 0198. The next number, 005 in the example, is an internal number used in processing the wage determination. 07/01/2014 is the effective date of the most current negotiated rate, which in this example is July 1, 2014.

Union prevailing wage rates are updated to reflect all rate changes in the collective bargaining agreement (CBA) governing this classification and rate.

#### Survey Rate Identifiers

Classifications listed under the "SU" identifier indicate that no one rate prevailed for this classification in the survey and the published rate is derived by computing a weighted average rate based on all the rates reported in the survey for that classification. As this weighted average rate includes all rates reported in the survey, it may include both union and non-union rates. Example: SULA2012-007 5/13/2014. SU indicates the rates are survey rates based on a weighted average calculation of rates and are not majority rates. LA indicates the State of Louisiana. 2012 is the year of survey on which these classifications and rates are based. The next number, 007 in the example, is an internal number used in producing the wage determination. 5/13/2014 indicates the survey completion date for the classifications and rates under that identifier.

Survey wage rates are not updated and remain in effect until a new survey is conducted.

#### Union Average Rate Identifiers

Classification(s) listed under the UAVG identifier indicate that no single majority rate prevailed for those classifications; however, 100% of the data reported for the classifications was union data. EXAMPLE: UAVG-OH-0010 08/29/2014. UAVG indicates that the rate is a weighted union average rate. OH indicates the state. The next number, 0010 in the example, is an internal number used in producing the wage determination. 08/29/2014 indicates the survey completion date for the classifications and rates under that identifier.

A UAVG rate will be updated once a year, usually in January of each year, to reflect a weighted average of the current negotiated/CBA rate of the union locals from which the rate is based.

---

#### WAGE DETERMINATION APPEALS PROCESS

1.) Has there been an initial decision in the matter? This can be:

- \* an existing published wage determination
- \* a survey underlying a wage determination
- \* a Wage and Hour Division letter setting forth a position on a wage determination matter
- \* a conformance (additional classification and rate) ruling

On survey related matters, initial contact, including requests for summaries of surveys, should be with the Wage and Hour Regional Office for the area in which the survey was conducted because those Regional Offices have responsibility for the Davis-Bacon survey program. If the response from this initial contact is not satisfactory, then the process described in 2.) and 3.) should be followed.

With regard to any other matter not yet ripe for the formal process described here, initial contact should be with the Branch of Construction Wage Determinations. Write to:

Branch of Construction Wage Determinations  
Wage and Hour Division  
U.S. Department of Labor  
200 Constitution Avenue, N.W.  
Washington, DC 20210

2.) If the answer to the question in 1.) is yes, then an interested party (those affected by the action) can request review and reconsideration from the Wage and Hour Administrator (See 29 CFR Part 1.8 and 29 CFR Part 7). Write to:

Wage and Hour Administrator  
U.S. Department of Labor

200 Constitution Avenue, N.W.  
Washington, DC 20210

The request should be accompanied by a full statement of the interested party's position and by any information (wage payment data, project description, area practice material, etc.) that the requestor considers relevant to the issue.

3.) If the decision of the Administrator is not favorable, an interested party may appeal directly to the Administrative Review Board (formerly the Wage Appeals Board). Write to:

Administrative Review Board  
U.S. Department of Labor  
200 Constitution Avenue, N.W.  
Washington, DC 20210

4.) All decisions by the Administrative Review Board are final.

=====

END OF GENERAL DECISION

**SECTION 00890 – PERMITS**

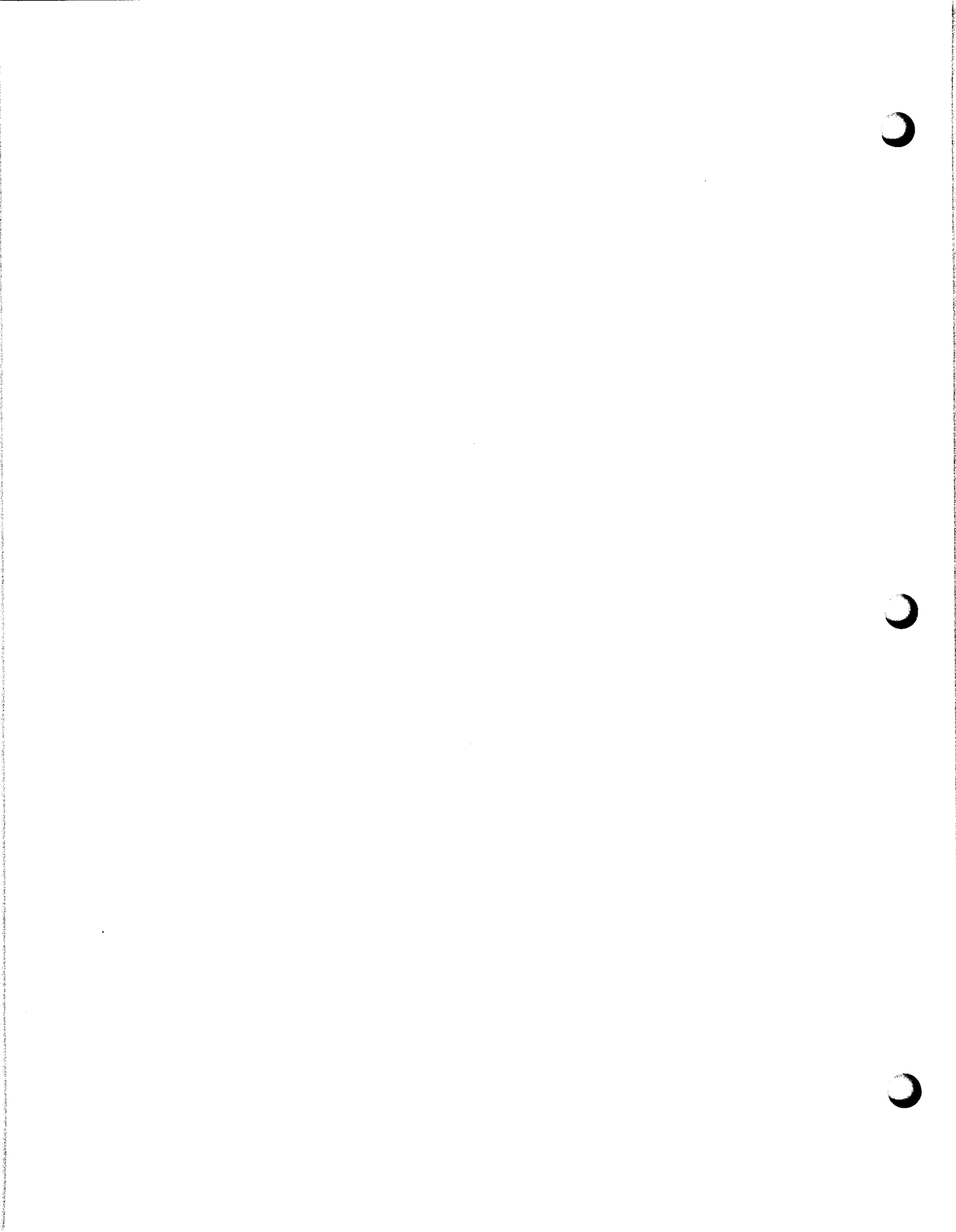

Rec'd 1/31/17



Matthew G. Bevin  
Governor

COMMONWEALTH OF KENTUCKY  
TRANSPORTATION CABINET  
Department of Highways, District 7 Office  
763 West New Circle Road  
Lexington, Kentucky 40511  
(859) 248-2355  
[www.transportation.ky.gov/](http://www.transportation.ky.gov/)

Greg Thomas  
Secretary

January 26, 2017

Lexington Fayette Urban Co. Govt.  
125 Lisle Industrial Avenue Suite 180  
Lexington, Kentucky 40511

Subject: Permit #: 07-2017-00038  
Permit Type: Utilities - Sewer  
Approval

Dear Applicant:

Attached is your permit approval and documentation for the subject permit.

Be advised that all work must be done in conformity with permit and application conditions. If you have any questions, please contact the Permits Section at this office.

Sincerely,

A handwritten signature in cursive script that reads "Kelly A. Baker".

Kelly A Baker  
D7 - Chief District Engineer

Attachments

A stylized, bold, and slightly italicized logo of the word "Kentucky" in a serif font.

An Equal Opportunity Employer M/F/D





**NOTICE OF COMPLETION OF ENCROACHMENT PERMIT WORK**

---

**PERMITEE**

Name: Lexington Fayette Urban Co. Govt.  
Contact Person:  
Address: 125 Lisle Industrial Avenue Suite 180  
City: Lexington  
State: Kentucky  
Zip: 40511  
Telephone:

**PROJECT IDENTIFICATION**

Permit Number: 07-2017-00038

---

I wish to notify the Department of Highways that the above mentioned permit work and any necessary right-of-way restoration have been completed and are ready for final inspection.

---

Applicant

---

Please return this form to the address below when work is completed and ready for final inspection.

Please Return to: Permit Engineer  
Department of Highways, District 7 Office  
763 West New Circle Road  
Lexington, Kentucky 40511  
(859) 246-2355  
[www.transportation.ky.gov/](http://www.transportation.ky.gov/)

LOCATION(S)			
Description	County, Route	Latitude	Longitude
175 MP 115.480	Fayette - I 75	38.101679	-84.489242





Kentucky Transportation Cabinet  
Department of Highways  
Permits Branch

TC 99-1 (A)  
8/2012  
Page 1 of 4

APPLICATION FOR ENCROACHMENT PERMIT

<b>Permittee Information</b>				KYTC No. <u>07-2017-00038</u>			
Name	Lexington Fayette Urban County Government			<b>Permit Information</b>			
Address	125 Lisle Industrial Avenue			Address			
	suite 180			City	Lexington		
City	Lexington			State	KY	Zip	40511
State	KY	Zip	40511	County	Fayette		
Phone#	859 258 - 3415			Route No.	<del>104</del> /175	Mile-Point	115.48
Contact	Vernon Azevedo P.E.			Longitude (X)	84 deg 29 min 21.36 sec		
Phone	859 425 - 2438	Cell	859 771 - 1155	Latitude (Y)	38 deg 06 min 05.54 sec		
Email	wazevedo@leingtonky.gov			<i>Information below to be filled out by KYTC</i>			
Contact	Benton Hanson, P.E.			<input type="checkbox"/> Air Right	<input type="checkbox"/> Entrance		
Phone	859 629-4838	Cell	859 361- 5983	<input checked="" type="checkbox"/> Utilities	<input type="checkbox"/> Other: _____		
Email	Benton.hanson@hdrinc.com						
				<input type="checkbox"/> Left	<input type="checkbox"/> Right	<input checked="" type="checkbox"/> X-ing	
<b>Access:</b>				<input checked="" type="checkbox"/> Full	<input type="checkbox"/> Partial	<input type="checkbox"/> by Permit	

General Description of Work:

Construction of a new 24" sewage force main to be contained within a 48" steel casing pipe under Interstates ~~104~~/175 for a LFUCG sewer improvement project.

THE UNDERSIGNED PERMITTEE(s) (being duly authorized representative(s) or owner(s)) DO AGREE TO ALL TERMS AND CONDITIONS ON THE TC 99-1 (A).

Kevin Levesque (KEVIN LEVESQUE)  
Signature

1/20/2017  
Date

This is not a permit unless and until the permittee(s) receives an approved TC 99-1(B) from KYTC. This application will become void if not approved by the cancellation date. The cancellation date will be one year from the date the permittee submits their application.



## APPLICATION FOR ENCROACHMENT PERMIT

### TERMS AND CONDITIONS

1. The permit, including this application and all related and accompanying documents and drawings making up the permit, remains in effect and is binding upon the Applicant/Permittee, its successors and assigns, as long as the encroachment(s) exists and also until the permittee is finally relieved by the Department of Highways from all its obligations.
2. Applicant shall meet all requirements of the Clean Water Act if the project will disturb one acre or more, the applicant shall obtain a KPDES KYR10 Permit from the Kentucky Division of Water. All disturbed areas shall meet the requirements of the Department of Highway's Standard Specifications, Sections 212 and 213, as amended.
3. **INDEMNITY:**
  - A. **PERFORMANCE BOND:** The permittee shall provide to the Department a performance bond according to the Permits Manual, Section PE-203 as a guarantee of conformance with the Department's Encroachment Permit requirements.
  - B. **PAYMENT BOND:** At the discretion of the department, a payment bond shall be required of the permittee to ensure payment of liquidated damages assessed to the permittee.
  - C. **LIABILITY INSURANCE:** Liability insurance shall be required of the permittee (in an amount approved by the department) to cover all liabilities associated with the encroachment.
  - D. It shall be the responsibility of the permittee, its successors and assigns, to maintain all indemnities in full force and effect until the permittee is authorized to release the Indemnity by the Department.
4. A copy of this application and all related documents making up the approved permit shall be given to the applicant and shall be made readily available for review at the work site at all times.
5. Perpetual maintenance of the encroachment is the responsibility of the permittee, its successors and assigns, with the approval of the Department as required, unless otherwise stated.
6. Permittee, its successors and assigns, shall comply with and agree to be bound by the requirements and terms of (a) this application and all related documents making up the approved permit, (b) by the Department's Permits Manual, and (c) by the Manual on Uniform Traffic Control Devices, both manuals as revised to and in effect on the date of issuance of the permit, all of which documents are made a part thereof by this reference. Compliance by the permittee, its successors and assigns, with subsequent revisions to applicable provisions of either manual or other policy of the Department may be made a condition of allowing the encroachment to persist under the permit.
7. Permittee agrees that this and any encroachment may be ordered removed by the Department at any time, and for any reason, upon thirty days written notice to the last known address of the applicant or to the address at the location of the encroachment. The permittee agrees that the cost of removing and of restoring the associated right-of-way is the responsibility of the permittee, its successors and assigns.
8. Permittee, its successors and assigns, agree that if the Department determines that motor vehicular safety deficiencies develop as a result of the installation or use of the encroachment, the permittee, its successors and assigns, shall provide and bear the expenses to adjust, relocate, or reconstruct the facilities, add signs, auxiliary lanes, or other corrective measures reasonably deemed necessary by the Department within a reasonable time after receipt of a written notice of such deficiency. The period within which such adjustments, relocations, additions, modifications, or other corrective measures must be completed will be specified in the notice.



### APPLICATION FOR ENCROACHMENT PERMIT

9. Where traffic signals are required as a condition of granting the requested permit or are thereafter required to correct motor vehicular safety deficiencies, as determined by the Department, the costs for signal equipment and installation(s) shall be borne by the permittee, its successors and assigns and the Department in its reasonable discretion and only in accordance with the Department's current policy set forth in the Traffic Operations Manual and Permits Manual. Any modifications to the permittee's entrance necessary to accommodate signalization (including necessary easement(s) on private property) shall be the responsibility of the permittee, its successors and assigns, at no expense to the Department.

10. The requested encroachment shall not infringe on the frontage rights of an abutting owner without their written consent as hereinafter described. Each abutting owner shall express their consent, which shall be binding on their successors and assigns, by the submission of a notarized statement as follows, "I (we), \_\_\_\_\_, hereby consent to the granting of the permit requested by the applicant along Route \_\_\_\_\_, which permit does affect frontage rights along my (our) adjacent real property." By signature(s) \_\_\_\_\_, subscribed and sworn by \_\_\_\_\_, on this date \_\_\_\_\_.

11. The permit, if approved, is subject to the agreement that it shall not interfere with any similar rights or permit(s) previously granted to any other party, except as otherwise provided by law.

12. Permittee shall include documentation which describes the facilities to be constructed. Permittee, its successors and assigns, agree as a condition of the granting of the permit to construct and maintain any and all permitted facilities or other encroachments in strict accordance with the submitted and approved permit documentation and the policies and procedures of the Department. Permittee, its successors and assigns, shall not use facilities authorized herein in any manner contrary to that prescribed by the approved permit. Only normal usage as contemplated by the parties and by this application and routine maintenance are authorized by the permit.

13. Permittee, its successors and assigns, at all times from the date permitted work is commenced until such time as all permitted facilities or other encroachments are removed from the right-of-way and the right-of-way restored, shall defend, protect, indemnify and save harmless the Department from any and all liability claims and demands arising out of the work, encroachment, maintenance, or other undertaking by the permittee, its successors and assigns, related or undertaken pursuant to the granted permit, due to any claimed act or omission by the permittee, its servants, agents, employees, or contractors. This provision shall not inure to the benefit of any third party nor operate to enlarge any liability of the Department beyond that existing at common law or otherwise if this right to indemnity did not exist.

14. Upon a violation of any provision of the permit, or otherwise in its reasonable discretion, the Department may require additional action by the permittee, its successors and assigns, up to and including the removal of the encroachment and restoration of the right-of-way. In the event additional actions required by the Department under the permit are not undertaken as ordered and within a reasonable time, the Department may in its discretion cause those or other additional corrective actions to be undertaken and the Department shall recover the reasonable costs of those corrective actions from the permittee, its successors and assigns.

15. Permittee, its successors and assigns, shall use the encroachment premises in compliance with all requirements of federal law and regulation, including those imposed pursuant to Title VI of the Civil Right Act of 1964 (42 U.S.C. § 2000d et seq.) and the related regulations of the U.S. Department of Transportation in Title 49 C.F.R. Part 21, all as amended.



### APPLICATION FOR ENCROACHMENT PERMIT

16. Permittee, its successors and assigns, agree that if the Department determines it is necessary for the facilities or other encroachment authorized by the permit to be removed, relocated or reconstructed in connection with the reconstruction, relocation or improvement of a highway, the Department may revoke permission for the encroachment to remain under the permit and may order its removal, relocation or reconstruction by the permittee, its successors and assigns, at the expense of the permittee, except where the Department is required by law to pay any or all of those costs.

17. Permittee agrees that the authorized permit is personal to the permittee and shall remain in effect until such time as (a) the permittee's rights to the adjoining real property to have benefitted from the requested encroachment have been relinquished, (b) until all permit obligations have been assumed by appropriate successors and assigns, and (c) unless and until a written release from permit obligations has been granted by the Department. The permit and its requirements shall also bind the real property to have benefitted from the requested encroachment to the extent permitted by law. The permit and the related encroachment become the responsibility of the successors and assigns of the permittee and the successors and assigns of each property owner benefitting from the encroachment, or the encroachment may not otherwise permissibly continue to be maintained on the right-of-way. (Does not apply to utility encroachments serving the general public.)

18. If work authorized by the permit is within a highway construction project in the construction phase, it shall be the responsibility of the permittee to make personal contact with the Department's Engineer on the project in order to coordinate all permitted work with the Department's prime contractor on the project.

19. This permit is not intended to, nor shall it, affect, alter or alleviate any requirement imposed upon the permittee, its successors and assigns, by any other agency.

20. Permittee, its successors and assigns, agree to contain and maintain all dirt, mud, and other debris emanating from the encroachment away from the surrounding right-of-way and the travel way of the highway hereafter and at all times that its obligations under the permit remain in effect.



Kentucky Transportation Cabinet  
 Department of Highways  
 Division of Maintenance  
 Permits Branch

TC 99-1 (B)  
 03/2016  
 Page 1 of 1

**ENCROACHMENT PERMIT**

**KEPT No.:** 07-2017-00038

**Permittee:** Lexington Fayette Urban Co. Govt.

**Permit Type / Subtype:** Utilities / Sewer

**Work Completion Date:** 7/1/2017

INDEMNITIES		
TYPE	Amount (dollars)	Tracking Number
Performance Bond	\$0.00	
ENCROACH	\$0.00	
SEWERING	\$15,000.00	0009633
ROADWAY BOND	\$0.00	
UTILITY INDEMNITY	\$0.00	

*attached D7-11*

This permit has been: APPROVED  DENIED

Kelly A Baker D7 - Chief District Engineer 1/25/2017

SIGNATURE *Kelly A. Baker* TITLE DATE

The TC 99-1(B), including the application TC-99 1(A) and all related and accompanying documents and drawings make up the permit. It is not a permit unless both the TC 99-1(A) and TC 99-1(B) are both present.

LOCATION(S)			
PROJECT	ROUTE / MILE	STATION	POSTMILE
175 MP 115.480	Fayette - I 75	38.101679	-84.489242

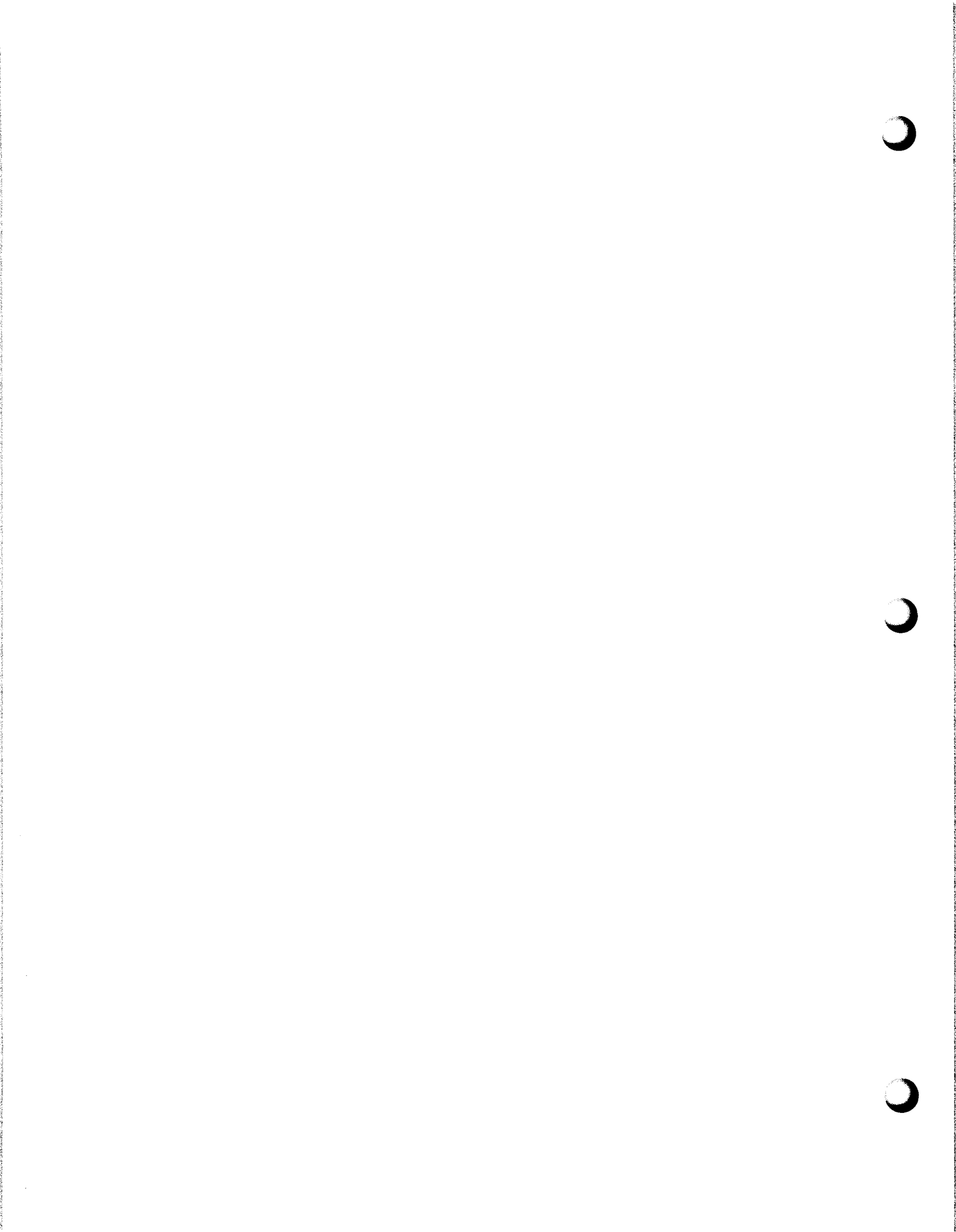



D7 - 16

• Rev. 2-88

Page 1 of 1

COMMONWEALTH OF KENTUCKY  
TRANSPORTATION CABINET  
DEPARTMENT OF HIGHWAYS  
ENCROACHMENT PERMIT MISCELLANEOUS REQUIREMENTS

---

THE FOLLOWING STIPULATIONS ARE REQUIREMENTS FOR YOUR APPROVED  
PERMIT NO. 07-2017-00038

- Any construction vehicles are prohibited on the I-75 ROW during installation for any reason. All work areas must be accessed from private property.

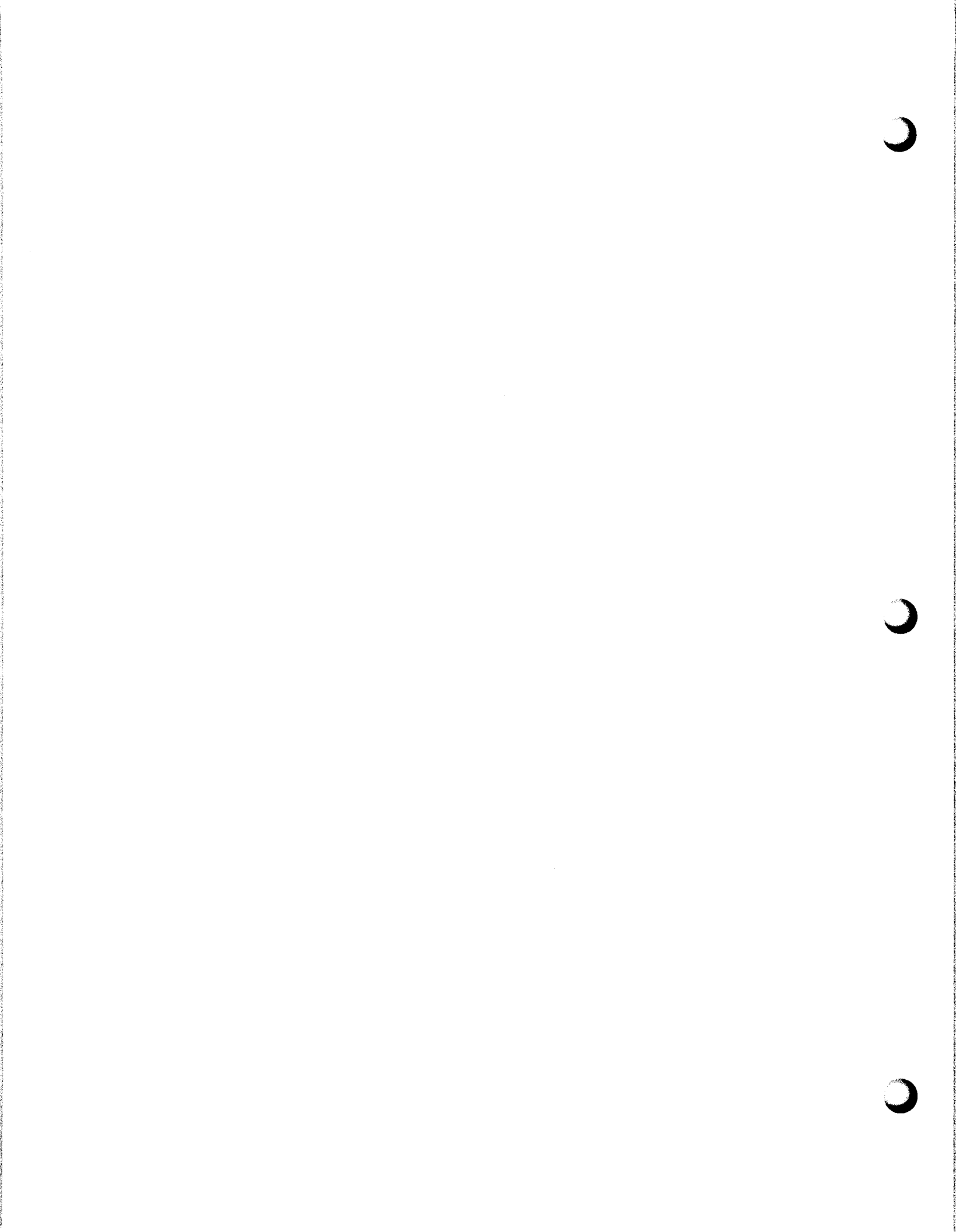



Kentucky Transportation Cabinet  
Department of Highways  
Permits Branch

TC 99-1 (A)  
8/2012  
Page 1 of 4

APPLICATION FOR ENCROACHMENT PERMIT

<b>Permittee Information</b>				KYTC No. <u>07-2017-00038</u>			
Name	Lexington Fayette Urban County Government			<b>Permit Information</b>			
Address	125 Lisle Industrial Avenue		Address				
	suite 180		City		Lexington		
City	Lexington		State		KY Zip 40511		
State	KY	Zip	40511		County Fayette		
Phone#	859 258 - 3415		Route No.		104/175 Mile-Point 115.48		
Contact	Vernon Azevedo P.E.		Longitude (X)		84 deg 29 min 21.36 sec		
Phone	859 425 - 2438	Cell	859 771 - 1155		Latitude (Y) 38 deg 06 min 05.54 sec		
Email	wazevedo@leingtonky.gov		<i>Information below to be filled out by KYTC</i>				
Contact	Benton Hanson, P.E.		<input type="checkbox"/> Air Right		<input type="checkbox"/> Entrance		
Phone	859 629-4838	Cell	859 361- 5983		<input checked="" type="checkbox"/> Utilities <input type="checkbox"/> Other: _____		
Email	Benton.hanson@hdrinc.com		<input type="checkbox"/> Left		<input type="checkbox"/> Right <input checked="" type="checkbox"/> X-Ing		
			Access:		<input checked="" type="checkbox"/> Full <input type="checkbox"/> Partial <input type="checkbox"/> by Permit		

General Description of Work:

Construction of a new 24" sewage force main to be contained within a 48" steel casing pipe under Interstates 104/175 for a LFUCG sewer improvement project.

THE UNDERSIGNED PERMITTEE(s) (being duly authorized representative(s) or owner(s)) DO AGREE TO ALL TERMS AND CONDITIONS ON THE TC 99-1 (A).

Kevin Lavoie (KEVIN LAVOIE)  
Signature

1/20/2017  
Date

This is not a permit unless and until the permittee(s) receives an approved TC 99-1(B) from KYTC. This application will become void if not approved by the cancellation date. The cancellation date will be one year from the date the permittee submits their application.



## APPLICATION FOR ENCROACHMENT PERMIT

### TERMS AND CONDITIONS

1. The permit, including this application and all related and accompanying documents and drawings making up the permit, remains in effect and is binding upon the Applicant/Permittee, its successors and assigns, as long as the encroachment(s) exists and also until the permittee is finally relieved by the Department of Highways from all its obligations.
2. Applicant shall meet all requirements of the Clean Water Act if the project will disturb one acre or more, the applicant shall obtain a KPDES KYR10 Permit from the Kentucky Division of Water. All disturbed areas shall meet the requirements of the Department of Highway's Standard Specifications, Sections 212 and 213, as amended.
3. **INDEMNITY:**
  - A. **PERFORMANCE BOND:** The permittee shall provide to the Department a performance bond according to the Permits Manual, Section PE-203 as a guarantee of conformance with the Department's Encroachment Permit requirements.
  - B. **PAYMENT BOND:** At the discretion of the department, a payment bond shall be required of the permittee to ensure payment of liquidated damages assessed to the permittee.
  - C. **LIABILITY INSURANCE:** Liability insurance shall be required of the permittee (in an amount approved by the department) to cover all liabilities associated with the encroachment.
  - D. It shall be the responsibility of the permittee, its successors and assigns, to maintain all indemnities in full force and effect until the permittee is authorized to release the indemnity by the Department.
4. A copy of this application and all related documents making up the approved permit shall be given to the applicant and shall be made readily available for review at the work site at all times.
5. Perpetual maintenance of the encroachment is the responsibility of the permittee, its successors and assigns, with the approval of the Department as required, unless otherwise stated.
6. Permittee, its successors and assigns, shall comply with and agree to be bound by the requirements and terms of (a) this application and all related documents making up the approved permit, (b) by the Department's Permits Manual, and (c) by the Manual on Uniform Traffic Control Devices, both manuals as revised to and in effect on the date of issuance of the permit, all of which documents are made a part thereof by this reference. Compliance by the permittee, its successors and assigns, with subsequent revisions to applicable provisions of either manual or other policy of the Department may be made a condition of allowing the encroachment to persist under the permit.
7. Permittee agrees that this and any encroachment may be ordered removed by the Department at any time, and for any reason, upon thirty days written notice to the last known address of the applicant or to the address at the location of the encroachment. The permittee agrees that the cost of removing and of restoring the associated right-of-way is the responsibility of the permittee, its successors and assigns.
8. Permittee, its successors and assigns, agree that if the Department determines that motor vehicular safety deficiencies develop as a result of the installation or use of the encroachment, the permittee, its successors and assigns, shall provide and bear the expenses to adjust, relocate, or reconstruct the facilities, add signs, auxiliary lanes, or other corrective measures reasonably deemed necessary by the Department within a reasonable time after receipt of a written notice of such deficiency. The period within which such adjustments, relocations, additions, modifications, or other corrective measures must be completed will be specified in the notice.



### APPLICATION FOR ENCROACHMENT PERMIT

9. Where traffic signals are required as a condition of granting the requested permit or are thereafter required to correct motor vehicular safety deficiencies, as determined by the Department, the costs for signal equipment and installation(s) shall be borne by the permittee, its successors and assigns and the Department in its reasonable discretion and only in accordance with the Department's current policy set forth in the Traffic Operations Manual and Permits Manual. Any modifications to the permittee's entrance necessary to accommodate signalization (including necessary easement(s) on private property) shall be the responsibility of the permittee, its successors and assigns, at no expense to the Department.

10. The requested encroachment shall not infringe on the frontage rights of an abutting owner without their written consent as hereinafter described. Each abutting owner shall express their consent, which shall be binding on their successors and assigns, by the submission of a notarized statement as follows, "I (we), \_\_\_\_\_, hereby consent to the granting of the permit requested by the applicant along Route \_\_\_\_\_, which permit does affect frontage rights along my (our) adjacent real property." By signature(s) \_\_\_\_\_ subscribed and sworn by \_\_\_\_\_, on this date \_\_\_\_\_.

11. The permit, if approved, is subject to the agreement that it shall not interfere with any similar rights or permit(s) previously granted to any other party, except as otherwise provided by law.

12. Permittee shall include documentation which describes the facilities to be constructed. Permittee, its successors and assigns, agree as a condition of the granting of the permit to construct and maintain any and all permitted facilities or other encroachments in strict accordance with the submitted and approved permit documentation and the policies and procedures of the Department. Permittee, its successors and assigns, shall not use facilities authorized herein in any manner contrary to that prescribed by the approved permit. Only normal usage as contemplated by the parties and by this application and routine maintenance are authorized by the permit.

13. Permittee, its successors and assigns, at all times from the date permitted work is commenced until such time as all permitted facilities or other encroachments are removed from the right-of-way and the right-of-way restored, shall defend, protect, indemnify and save harmless the Department from any and all liability claims and demands arising out of the work, encroachment, maintenance, or other undertaking by the permittee, its successors and assigns, related or undertaken pursuant to the granted permit, due to any claimed act or omission by the permittee, its servants, agents, employees, or contractors. This provision shall not inure to the benefit of any third party nor operate to enlarge any liability of the Department beyond that existing at common law or otherwise if this right to indemnity did not exist.

14. Upon a violation of any provision of the permit, or otherwise in its reasonable discretion, the Department may require additional action by the permittee, its successors and assigns, up to and including the removal of the encroachment and restoration of the right-of-way. In the event additional actions required by the Department under the permit are not undertaken as ordered and within a reasonable time, the Department may in its discretion cause those or other additional corrective actions to be undertaken and the Department shall recover the reasonable costs of those corrective actions from the permittee, its successors and assigns.

15. Permittee, its successors and assigns, shall use the encroachment premises in compliance with all requirements of federal law and regulation, including those imposed pursuant to Title VI of the Civil Right Act of 1964 (42 U.S.C. § 2000d et seq.) and the related regulations of the U.S. Department of Transportation in Title 49 C.F.R. Part 21, all as amended.



### APPLICATION FOR ENCROACHMENT PERMIT

**16.** Permittee, its successors and assigns, agree that if the Department determines it is necessary for the facilities or other encroachment authorized by the permit to be removed, relocated or reconstructed in connection with the reconstruction, relocation or improvement of a highway, the Department may revoke permission for the encroachment to remain under the permit and may order its removal, relocation or reconstruction by the permittee, its successors and assigns, at the expense of the permittee, except where the Department is required by law to pay any or all of those costs.

**17.** Permittee agrees that the authorized permit is personal to the permittee and shall remain in effect until such time as (a) the permittee's rights to the adjoining real property to have benefitted from the requested encroachment have been relinquished, (b) until all permit obligations have been assumed by appropriate successors and assigns, and (c) unless and until a written release from permit obligations has been granted by the Department. The permit and its requirements shall also bind the real property to have benefitted from the requested encroachment to the extent permitted by law. The permit and the related encroachment become the responsibility of the successors and assigns of the permittee and the successors and assigns of each property owner benefitting from the encroachment, or the encroachment may not otherwise permissibly continue to be maintained on the right-of-way. (Does not apply to utility encroachments serving the general public.)

**18.** If work authorized by the permit is within a highway construction project in the construction phase, it shall be the responsibility of the permittee to make personal contact with the Department's Engineer on the project in order to coordinate all permitted work with the Department's prime contractor on the project.

**19.** This permit is not intended to, nor shall it, affect, alter or alleviate any requirement imposed upon the permittee, its successors and assigns, by any other agency.

**20.** Permittee, its successors and assigns, agree to contain and maintain all dirt, mud, and other debris emanating from the encroachment away from the surrounding right-of-way and the travel way of the highway hereafter and at all times that its obligations under the permit remain in effect.



Kentucky Transportation Cabinet  
 Department of Highways  
 Division of Maintenance  
 Permits Branch

TC 99-1 (B)  
 03/2016  
 Page 1 of 1

**ENCROACHMENT PERMIT**

**KEPT No.:** 07-2017-00038

---

**Permittee:** Lexington Fayette Urban Co. Govt.

---

**Permit Type / Subtype:** Utilities / Sewer

---

**Work Completion Date:** 7/1/2017

---

INDEMNITIES		
Type	Amount Required	Check No.
Performance Bond	\$0.00	
Cost of Signage	\$0.00	
Signage	\$15,000.00	0009633
Payment of PI	\$0.00	
Utility Indemnity	\$0.00	

*attached D7-11*

This permit has been: **APPROVED**  **DENIED**

Kelly A Baker	D7 - Chief District Engineer	1/25/2017
<b>SIGNATURE</b> <i>Kelly A. Baker</i>	<b>TITLE</b>	<b>DATE</b>

The TC 99-1(B), including the application TC-99 1(A) and all related and accompanying documents and drawings make up the permit. It is not a permit unless both the TC 99-1(A) and TC 99-1(B) are both present.

COORDINATES			
Description	Stationing	Easting	Northing
I 75 MP 115.480	Fayette - I 75	38.101679	-84.488242





COMMONWEALTH OF KENTUCKY  
TRANSPORTATION CABINET  
DEPARTMENT OF HIGHWAYS  
ENCROACHMENT PERMIT MISCELLANEOUS REQUIREMENTS

---

THE FOLLOWING STIPULATIONS ARE REQUIREMENTS FOR YOUR APPROVED PERMIT NO. 07-2017-00038

- Any construction vehicles are prohibited on the I-75 ROW during installation for any reason. All work areas must be accessed from private property.





## ENCROACHMENT PERMIT GENERAL NOTES & SPECIFICATIONS

Permit No. ROAD BORE

### I. SAFETY

#### A. General Provisions

- All signs and control of traffic shall be in accordance with the Manual on Uniform Traffic Control Devices for Streets and Highways, latest edition, Part VI, and safety requirements shall comply with the Permits Manual.
- All work necessary in shoulder or ditch line areas of a state highway shall be scheduled to be promptly completed so that hazards adjacent to the traveled way are kept to an absolute minimum.
- No more than one (1) traveled-lane shall be blocked or obstructed during normal working hours. All signs and flaggers during lane closure shall conform to the Manual on Uniform Traffic Control Devices.
- When necessary to block one (1) traveled-lane of a state highway, the normal working hours shall be as directed by the Department. No lanes shall be blocked or obstructed during adverse weather conditions (rain, snow, fog, etc.) without specific permission from the Department. Working hours shall be between 9:00 a.m. and 3:30 p.m.
- The traveled-way and shoulders shall be kept clear of mud and other construction debris at all times during construction of the permitted facility.
- No nonconstruction equipment or vehicles or office trailers shall be allowed on the right of way during working hours.
- The right of way shall be left free and clear of equipment, material, and vehicles during non-working hours.

#### B. Explosives

- No explosive devices or explosive material shall be used within state right of way without proper license and approval of the Kentucky Department of Mines and Minerals, Explosive Division.

#### C. Other Safety Requirements

- All workers within right-of-way shall wear high-visibility safety apparel that meets the Performance Class 2 or 3 requirements of the ANSI/ISEA 107-2004 publication entitled "American National Standard for Safety Apparel and Headwear"

### II. UTILITIES - Buried Utilities, Cables, and Other Facilities

- \*All work necessary within the right of way shall be performed behind a temporary fence erected prior to a boring operation.
- \*The temporary woven wire fence shall be removed immediately upon completion of work on the right of way, and the control of access immediately restored to original condition, in accordance with applicable Kentucky Department of Highways Standard Drawings.
- \*All vents, valves, manholes, etc., shall be located outside of the right-of-way.
- \*Encasement pipe shall extend from right-of-way line to right-of-way line and shall be one continuous run of pipe. The encasement pipe shall be welded at all joints.
- The boring pit and tail ditch shall extend past the existing toe of slope or bottom of ditch line and shall be a minimum of 42 inches deep.

**IV. RIGHT OF WAY RESTORATION**

All disturbed portions of the right of way shall be restored to grass as per Kentucky Department of Highways Standard Specifications for Road and Bridge Construction (latest edition). A satisfactory turf, as determined by the Department, shall be established by the permittee prior to release of indemnity. Sodding or seeding shall be as follows:

Lawn or High Maintenance Situation

70% Lawn Fescue (e.g., variety - Falcon)  
30% Bluegrass or

70% Lawn Rye (e.g., variety - Derby)  
30% Bluegrass

Right of Way Lawn Maintenance Situation

70% KY 31 Fescue  
30% Perennial Rye Grass or

100% KY Fescue

- Two tons of clean straw mulch per acre of seeding.
- Prior to seeding, the ground shall be prepared in accordance with Kentucky Department of Highways Standard Specifications for Road and Bridge Construction (latest edition).
- Substitutes for sod such as artificial turf, rocked mulch, or paved areas may be acceptable if they are aesthetically pleasing.
- All ditch-flow lines and all ditch-side slopes shall be sodded.
- Existing concrete right of way markers shall not be disturbed, but if damaged in any way, they shall be entirely replaced by the permittee, with new concrete markers to match the original markers, in accordance with Kentucky Department of Highways Standard Drawings. Markers that are entirely removed shall be re-established in the proper locations by the permittee and to the satisfaction of the Department.
- Other right of way restoration requirements are as follows:

**V. DRAINAGE**

- All pipe shall be laid in a straight alignment, to proper grades, and with all materials and methods of installation including bedding and joint seating in accordance with Department Standard Specifications for Road and Bridge Construction (latest edition). Pipe shall not be covered until inspected by the Department and express permission obtained to make backfill.
- All gutter lines at the base of new curbs shall be on continuous grades, and pockets of water along with curbs or in entrance areas or other paved areas within the right of way shall not be acceptable.
- All drainage structures and appurtenances (manholes, catch basins, curbing, inlet basins, etc.) shall conform to Department specifications and shall be constructed in accordance with the Department Standard Drawings. Type required:

---

---

Kentucky Transportation Cabinet  
 Department of Highways  
 Permits Branch

EXHIBIT 8

TC 99-10  
 Rev. 9/200

TYPICAL HIGHWAY BORING CROSSING DETAIL

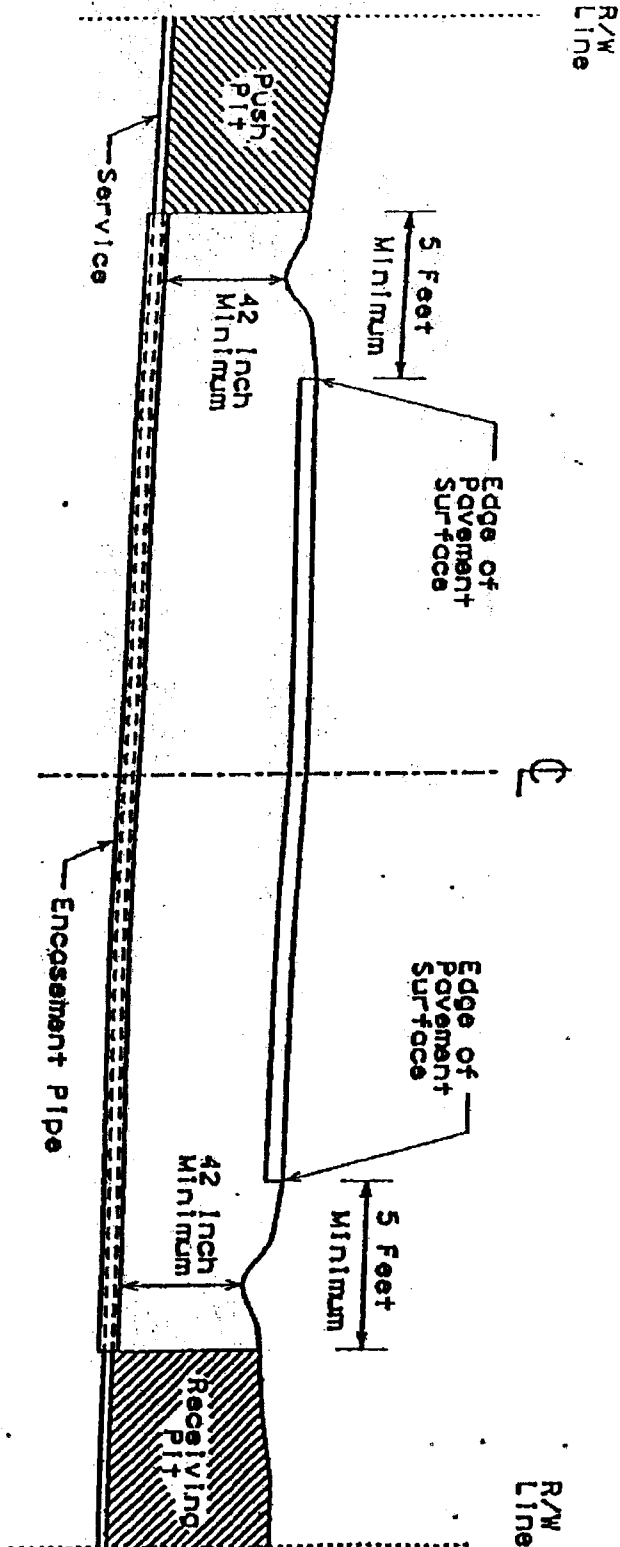

Permit No. \_\_\_\_\_  
 Route No. \_\_\_\_\_  
 Pavement Width \_\_\_\_\_

1. Push pit and Receiving Pit shall be backfilled and thoroughly compacted.
2. All ditch lines are to remain open at all times.
3. Seed and straw all disturbed areas immediately after completing the work.
4. Provide traffic control as required to insure the safety of the travelling public in accordance with the current edition of the Manual on Uniform Traffic Control Devices.

ALL SERVICES OVER 2" IN DIAMETER SHALL REQUIRE ENCASEMENT.



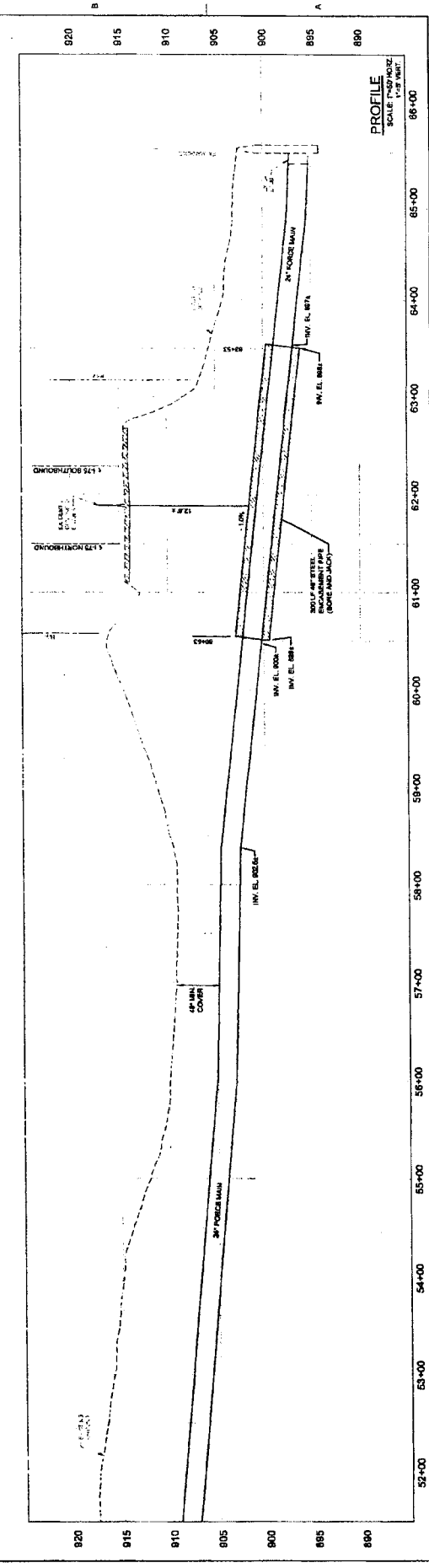
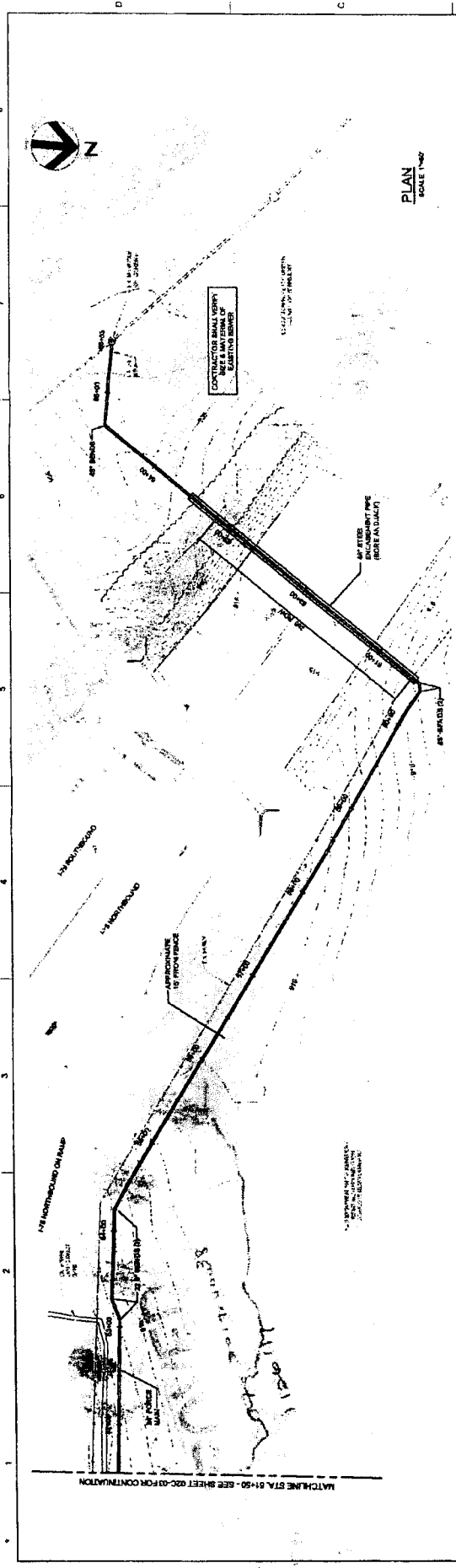

**EXPANSION AREA 3  
PUMP STATION AND FORCE MAIN  
IMPROVEMENTS**

**FORCE MAIN  
STA. 51+50 TO STA. 65+56.13**

**PRELIMINARY  
NOT FOR  
CONSTRUCTION OR  
RECORDING**

PROJECT NUMBER: 15041100  
DATE: 02/15/11

PROJECT MANAGER: B. BENTON HANSEN  
DESIGNER: G. T. COLVIN  
CHECKED: GAC  
DATE: 02/15/11

PROJECT NUMBER: 15041100  
DATE: 02/15/11

PROJECT NUMBER: 15041100  
DATE: 02/15/11

PROJECT NUMBER: 15041100  
DATE: 02/15/11

PROJECT NUMBER: 15041100  
DATE: 02/15/11

PROJECT NUMBER: 15041100  
DATE: 02/15/11







# Kentucky Infrastructure Authority

## Cost & Effectiveness Self Certification



In accordance with Section 602(b)(13) of the Clean Water Act, as amended:

(13) ... the recipient of such assistance must certify, in a manner determined by the Governor of the State, that the recipient:

- A) Has studied and evaluated the cost and effectiveness of the processes, materials, techniques, and technologies for carrying out the proposed project or activity for which assistance is sought under this title; and
- B) Has selected, to the maximum extent practicable, a project or activity that maximizes the potential for efficient water use, reuse, recapture, and conservation, and energy conservation, taking into account -
  - i. The cost of constructing the project or activity;
  - ii. The cost of operating and maintaining the project or activity over the life of the project or activity; and
  - iii. The cost of replacing the project or activity.

Check the appropriate statement below and sign the signature block.

For Planning and Design Loans: By signing below, the loan recipient agrees to develop and implement a cost and effectiveness analysis that meets the requirements of clauses (A) and (B) above.

For Construction Loans: By signing below, the loan recipient certifies that:  
1. A planning document served as the basis for selection of the recommended alternative; and  
2. The undersigned agrees to develop a summary of findings from the planning document that addresses the requirements of clauses (A) and (B) above.

Loan Number: A17-016 Project Number: SX21067002

Name and Title of Authorized Official: Kevin Levesque - Project Manager

Signature of Authorized Official:  Date: 01/09/2017

Name of Professional Engineer: P. Benton Hanson, PE - HDR Inc

# Kentucky Infrastructure Authority

## Fiscal Sustainability Plan Self Certification

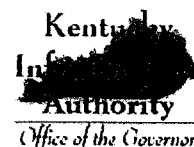

As stated in section 603(d)(1)(E) of the *Federal Water Pollution Control Act*, as amended:

- (E) for a treatment works proposed for repair, replacement, or expansion, and eligible for assistance under subsection (c)(1), the recipient of a loan shall –
- i. develop and implement a fiscal sustainability plan that includes –
    - I. an inventory of critical assets that are part of the treatment works;
    - II. an evaluation of the conditions and performance of inventoried assets or asset groupings;
    - III. a certification that the recipient has evaluated and will be implementing water and energy conservation efforts as part of the plan; and
    - IV. a plan for maintaining, repairing, and, as necessary, replacing the treatment works and a plan for funding such activities; or
  - ii. certify that the recipient has developed and implemented a plan that meets requirements under clause (i);

Check the appropriate statement below and sign the signature block.

- By signing below, the loan recipient agrees to utilize the Water Resource Information System (WRIS) Asset Management tool to develop and implement a Fiscal Sustainability Plan as described above.
- By signing below, the loan recipient certifies that they have developed a planning document that will satisfy the requirements as described above.

Loan Number: A17-016 Project Number: SX21067002

Name and Title of Authorized Official: Kevin Levesque - Project Manager

Signature of Authorized Official:  Date: 01/09/2017

Name of Professional Engineer: P. Benton Hanson, PE - HDR Inc



**KENTUCKY  
AMERICAN WATER**

2300 Richmond Road  
Lexington, KY 40502  
Customer Service: (800) 678-6301  
Fax: (859) 268-6315  
[www.kentuckyamwater.com](http://www.kentuckyamwater.com)

## NEW SERVICE PROCESS

(2" and smaller)

### STEP 1

To request new service we will need the following:

- Tap Application Form
- Contract or Master Agreement Number\*
- State Plumbing Inspection to verify if inspection is complete  
(Visit [www.approvedwaterservices.com](http://www.approvedwaterservices.com) for updates)
- Tap Fee
- Backflow Prevention Survey (for non-residential services only)

*Fees effective August 28, 2016:*

5/8" meter	<b>\$1,280.00</b>
1" meter	<b>\$2,201.00</b>
2" meter	<b>\$4,238.00</b>

*\*You may fill out a master agreement form to avoid having to complete a contract with each application.*

### STEP 2

Submit completed tap application form\*\* and fee by mail or deliver to:

ATTN: New Services  
Kentucky American Water  
2300 Richmond Road  
Lexington, KY 40502

### STEP 3

Once all information is submitted:

- If requesting a new installation, service will be installed within 20 to 25 business days.
- If setting is already installed (dual setting), an order is sent to field representative and meter is installed within 5 to 10 business days.
- Order is returned to office and account is set up for billing.

*\*\* Incomplete applications will be returned.*

### STEP 4

To inquire or follow up on application process:

- Call and leave a message on 24-hour Tap Line at (859) 268-6379
- Fax inquiry to the attention of "New Services" at (859) 268-6315

**REMEMBER:** When inquiring about the status of your application, remember to leave:

- Name and contact phone number
- Address about which you are inquiring

You should receive a response or return call the same day or within 24 hours (one business day). You may also contact our Customer Service Center at 1-800-678-6301, and if they are unable to assist you (due to the process being handled locally), they will get a message to our local dispatcher who will contact you.

All new customers should call the Customer Service Center (available 24 hours a day, seven days a week) at 1-800-678-6301 to have service set up in their names. All information can be found on our Web site at [www.kentuckyamwater.com](http://www.kentuckyamwater.com).

# NEW TAP APPLICATION



**PLEASE COMPLETE AND RETURN TO:**

Attn: New Taps  
 Kentucky American Water  
 2300 Richmond Road  
 Lexington, KY 40502  
 24-Hour Tap Line #: (859) 268-6379  
 Fax #: (859) 268-6315  
 www.kentuckyamwater.com

**FOR OFFICE USE ONLY:**

Plumbing Permit #:			
Inspection Date:			
Customer #:		Account #:	
Premise#:			
Private Setting:	Yes	No:	
<i>If yes, inspected and approved by :</i>			
WBS#		Spec Conn Agmt (or Multiple Svc Agmt) #:	
Type of service:		Size:	
Amount Paid		Date Paid:	

**IMPORTANT:** This application must be completed and returned with the tap fee. Proof of inspection and approval of water service by State Plumbing Inspector required. A signed "Contract for New Service" is required unless a "Master Service Agreement" has been executed. Allow 20-25 days for service to be installed after all paperwork is received. **(PLEASE NOTE: Services larger than 2" are applied for and coordinated through the New Development/Construction Department. Installation time will vary, but will be a minimum of 90 days after application is made.)**

**PLEASE ENSURE ADDRESS IS MARKED AND VISIBLE FROM THE STREET**

The undersigned makes application for water service at Address \_\_\_\_\_  
 County \_\_\_\_\_ Subdivision \_\_\_\_\_ City \_\_\_\_\_ Zip \_\_\_\_\_

and hereby requests Kentucky American Water to make a connection to its main. **Kentucky American Water will specify the location, size, kind and quality of all material entering into the service connection and will set and turn on the meter.** The undersigned has completed the following requirements for the installation of a water meter at the above address:

- Service line has been installed to the point where the meter is to be permanently connected **and** visibly marked by the customer to identify the connection point. **Non-residential service lines are required to have a testable approved backflow prevention device installed.**
- The service line which connects the customer supply at the meter setting is \_\_\_\_\_ inch (minimum 3/4") and will require a \_\_\_\_\_-inch meter to be set (1 1/2" and larger meters require a completed Customer Data Sheet). The service line is at 30 inches below ground level. **Service lines up to 2"** will have Type "L" or "K" copper line installed at the connection point or affixed with a male adapter at the connection point if the customer's line is other than Type "L" or "K" copper. **Service lines larger than 2"** will have Ductile Iron pipe or C-900 plastic pipe installed to the connection point. If another type of pipe is used at the connection point, the customer is required to make the connection; and
- This service line is equipped with an easily accessible stop and waste valve inside and near the foundation of the building being supplied.

**THE UNDERSIGNED AGREES TO THE FOLLOWING:**

- Comply with all rules and regulations of Kentucky American Water, as approved by the Kentucky Public Service Commission.
- Comply with local codes and ordinances in the construction, use and alteration of the plumbing system.
- If non-residential, shall install an approved backflow prevention device to avert a cross connection or backflow condition.
- Shall not create an electric shock hazard by improper electric grounding to the plumbing system. Kentucky American Water assumes no responsibility for continuity of electrical grounding systems by the installation or removal of its meter.
- Must, at all times, take necessary measures to protect the meter box, meter setting and service line and is responsible for damages to Kentucky American Water property caused by them, their contractor and/or subcontractors.

**THIS METER SERVES THE FOLLOWING PREMISE TYPE (CHECK ONE):**

- Residential (single premise residence, duplex or multiple premise residence where each unit is served by its own meter).
- Commercial (multiple premise residence [apartment building] served by a single meter, private educational institutions, all businesses where water is not used principally in manufacturing or processing of a product. Commercial includes laundries, hotels, motels, restaurants, bars, non-government office buildings, non-government hospitals and other medical facilities, retail shops, etc.)
- Industrial (manufacturing or processing establishments where the water is used principally in the manufacturing or processing of a product. Industrial includes factories, refineries, bottling plants, etc.)
- Other Public Authority (OPA) (municipal, county, state or federal agencies). OPA includes municipal buildings, public schools, public libraries, government hospitals, fire stations, public housing developments, etc.
- Sales for Resale (sales to private or public water utilities where the water is to be resold to the customers of the utility).

**SEWER SERVICE PROVIDED BY (CHECK ONE):**

- LFUCG
- GEORGETOWN MUNICIPAL
- ROCKWELL VILLAGE
- TREE HAVEN
- SEPTIC
- IRRIGATION ONLY
- OTHER
- N/A (FIRE HYDRANT/FIRE SERVICE)

Owner/Builder \_\_\_\_\_  
 Master Agreement Number (if applicable) \_\_\_\_\_  
 Phone: \_\_\_\_\_ Plumber Name \_\_\_\_\_  
 Authorized Signature \_\_\_\_\_ Title \_\_\_\_\_ Date \_\_\_\_\_

# CONTRACT FOR NEW SERVICE



**FOR KENTUCKY AMERICAN WATER OFFICE USE ONLY:**

Premise No.: \_\_\_\_\_ Acct. No.: \_\_\_\_\_ Customer No.: \_\_\_\_\_  
Application for Special Connection No.: \_\_\_\_\_ WBS No.: \_\_\_\_\_  
Type of Service: \_\_\_\_\_  
Person assigned: \_\_\_\_\_

I hereby make application and authorize Kentucky American Water to place a meter and turn on the water at the following address, and I agree to pay all bills by the due date specified on the bill for water furnished to any address where I either have an interest in the ownership of the property, directly or indirectly, or have requested service, and I hereby agree to continue to be responsible for the same until I notify Kentucky American Water in writing to the contrary.

I agree to take the necessary measures to protect the meter box, meter setting and the service during the installation of new services. I will be responsible for damages to Kentucky American Water property caused by me, my contractor and/or sub-contractor during on-site construction.

I agree to abide by the local codes and ordinances in the construction, use, and alteration of my plumbing system. I shall not create an electric shock hazard by improper electric grounding to the plumbing system. I agree to install an approved, testable backflow prevention device on all nonresidential incoming lines and irrigation systems to prevent the creation of a cross connection or backflow condition.

Kentucky American Water assumes no responsibility for continuity of electrical grounding systems by the installation or removal of its meter.

I agree to abide by and comply with all rules, regulations and rates of Kentucky American Water, as approved by the Public Service Commission of the Commonwealth of Kentucky and as changed from time to time.

If, at any time, any bill owed by me to Kentucky American Water, whether collectible under this Agreement or otherwise, is not paid when due and payable, then Kentucky American Water shall have the right to discontinue the supply of water to the location.

**PLEASE COMPLETE THE FOLLOWING INFORMATION (return with deposit and signed agreements)**

Service Address \_\_\_\_\_

City \_\_\_\_\_ State \_\_\_\_\_ Zip Code \_\_\_\_\_

Is this a multi-unit building?  Yes  No If yes, how many units \_\_\_\_\_

Please check primary use of service:  Residential  Commercial  Industrial  OPA

Please check type (s) of service use (if more than one type or number, individual application is required for each service)

Domestic  Irrigation  Fire service -- size: \_\_\_\_\_  Fire hydrant -- quantity: \_\_\_\_\_  Other

Billing Name \_\_\_\_\_

Billing Address, if different from service address \_\_\_\_\_

City \_\_\_\_\_ State \_\_\_\_\_ Zip Code \_\_\_\_\_

Telephone number: (Home) \_\_\_\_\_ (Office) \_\_\_\_\_

Name of person filling out form \_\_\_\_\_

Contact Person \_\_\_\_\_ Phone Number \_\_\_\_\_

Do you own or lease this building? Own \_\_\_\_\_ Lease \_\_\_\_\_

Authorized Signature \_\_\_\_\_ Title \_\_\_\_\_ Date \_\_\_\_\_



**KENTUCKY  
AMERICAN WATER**

2300 Richmond Road  
Lexington, KY 40502  
1-800-678-6301  
www.kentuckyamwater.com

# MASTER AGREEMENT FOR NEW SERVICE

Agreement Number \_\_\_\_\_

Customer Name \_\_\_\_\_

Billing Address \_\_\_\_\_

\_\_\_\_\_ Zip Code \_\_\_\_\_

Daytime Phone Number \_\_\_\_\_ Evening/Weekend Phone \_\_\_\_\_

Have you had water service with Kentucky American Water before? YES NO (Circle one)

I hereby make application and authorize Kentucky American Water to place a meter and turn on the water for all addresses for which a Tap Application is signed by me or a representative and I agree to pay all bills by the due date specified on the bill for water furnished to any address which I either have an interest in the ownership of the property, directly or indirectly or have requested service, and I hereby agree to continue to be responsible for the same until I notify Kentucky American Water in writing to the contrary.

I agree to take the necessary measures to protect the meter box, meter setting and the service during the installation of new services. I will be responsible for damages to Kentucky American Water property caused by me, my contractor and/or sub-contractor during on-site construction.

I agree to abide by local codes and ordinances in the construction, use and alteration of my plumbing system. I shall not create cross connection or backflow conditions. I shall not create an electric shock hazard by improper electric grounding to the plumbing system. Kentucky American Water assumes no responsibility for continuity of electrical grounding systems by the installation or removal of its meter.

I agree to abide by and comply with all rules, regulations and rates of Kentucky American Water as approved by the Public Service Commission of the Commonwealth of Kentucky and as changed from time to time.

If, at any time, any bill owed by me to Kentucky American Water, whether collectible under this agreement or otherwise, is not paid when due and payable, then Kentucky American Water shall have the right to discontinue the supply of water to all addresses for which I have submitted an application for service from Kentucky American Water.

Authorized signature \_\_\_\_\_ Title \_\_\_\_\_ Date \_\_\_\_\_

Please print names of persons authorized to sign for service:

NAME \_\_\_\_\_

NAME \_\_\_\_\_

NAME \_\_\_\_\_

NAME \_\_\_\_\_

NAME \_\_\_\_\_

NAME \_\_\_\_\_

Please notify us of any changes to this authorization list.

## KENTUCKY AMERICAN WATER Water Customer Data Sheet

Customer:		Address	
Building Address:			
Subdivision:		Lot No:	
Type of Occupancy:			

Fixture	Number of Fixtures
Bathtub	
Bedpan Washers	
Combination Sink and Tray	
Dental Unit	
Dental Lavatory	
Drinking Fountain - Cooler	
Drinking Fountain - Public	
Kitchen Sink - 1/2" Connection	
Kitchen Sink - 3/4" Connection	
Lavatory Tray - 3/8" Connection	
Lavatory Tray - 1/2" Connection	
Laundry Tray - 1/2" Connection	
Laundry Tray - 3/4" Connection	
Shower Head (Shower only)	
Service Sink - 1/2" Connection	
Service Sink - 3/4" Connection	
Urinal- Pedestal Flush Valve	
Urinal- Wall Flush Valve	
Urinal - Trough (2ft. Unit)	
Wash Sink (each set of faucets)	
Water Closet - Flush Valve	
Water Closet - Tank Type	
Dishwasher - 1/2" Connection	
Dishwasher - 3/4" Connection	
Washing Machine - 1/2" Connection	
Washing Machine - 3/4" Connection	
Washing Machine - 1" Connection	
Hose Connection (Wash Down) - 1/2"	
Hose Connection (Wash Down) - 3/4"	
Hose (50 feet Wash Down) 1/2"	
Hose (50 feet Wash Down) 5/8"	
Hose (50 feet Wash Down) 3/4"	

**BACKFLOW PREVENTION SURVEY**  
(For non-residential customers)

Please complete and return this survey with your tap application so that we can determine the appropriate back flow device requirements for your new service. Should you have any questions or need assistance in completing this survey please call (859) 268-6310.

**Service Address:**

**City:**

<p>Please answer the following questions if your service request is for <b>Commercial, Industrial, or Public Authority Account:</b></p> <ul style="list-style-type: none"> <li>• <u>Check the box or boxes that best describes the use of water with your facility:</u> <ul style="list-style-type: none"> <li><input type="checkbox"/> Typical, such as bathrooms, drinking fountains, outside water faucets, household laundry or dishwashing appliances</li> <li><input type="checkbox"/> Private well(s) supplying any part of your facility</li> <li><input type="checkbox"/> Piped into a manufacturing process</li> <li><input type="checkbox"/> Piped into a chemical process</li> <li><input type="checkbox"/> Piped, underground lawn irrigation system</li> <li><input type="checkbox"/> Piped into a swimming pool</li> <li><input type="checkbox"/> Piped into water operated/cooled equipment/appliances</li> </ul> </li> <li>• <u>Check the types of backflow prevention devices installed on your plumbing system. (Residential Dual Check valves are not acceptable)</u> <ul style="list-style-type: none"> <li><input type="checkbox"/> None</li> <li><input type="checkbox"/> Reduced Pressure Zone device (RPZ)</li> <li><input type="checkbox"/> Testable Double Check Valve(DCV)</li> <li><input type="checkbox"/> Pressure Vacuum Breaker (PVB) –for use on underground irrigation systems only</li> <li><input type="checkbox"/> Other _____</li> </ul> </li> </ul>	<p>Please answer the following questions if your service request is for <b>Fire Protection:</b></p> <ul style="list-style-type: none"> <li>• <u>Check the box or boxes that best describes your fire protection account:</u> <ul style="list-style-type: none"> <li><input type="checkbox"/> This account serves private hydrants only (no fire sprinkler system in facility)</li> <li><input type="checkbox"/> This account serves an installed fire sprinkler system</li> <li><input type="checkbox"/> Fire sprinkler system has outside fire department connections for pumping into the system</li> <li><input type="checkbox"/> Fire sprinkler system contains antifreeze or other chemicals</li> <li><input type="checkbox"/> Fire sprinkler system is also supplied by an auxiliary source of water (i.e., pond, reservoir, or storage tank)</li> </ul> </li> <li>• <u>Check the types of backflow prevention devices installed on your sprinkler system if applicable.</u> <ul style="list-style-type: none"> <li><input type="checkbox"/> None</li> <li><input type="checkbox"/> Reduced Pressure Zone device (RPZ)</li> <li><input type="checkbox"/> Double Detector Check Assembly (DDCA)</li> <li><input type="checkbox"/> Testable Double Check Valve (DCV)</li> <li><input type="checkbox"/> Other _____</li> </ul> </li> </ul>
---	---

**IMPORTANT:** If backflow prevention devices are installed on your plumbing/fire sprinkler system, they are required to be tested annually and copies of the test reports must be maintained on file with Kentucky American Water. If you do not have current copies of the test reports on file with us, please attach copies of the test(s) to this survey.

\_\_\_\_\_  
Date Signature of person completing survey Phone Number

**Please mail or fax completed survey to:** Kentucky American Water  
2300 Richmond Rd.  
Lexington, KY 40502  
Attn. Cross Connection Supervisor



SECTION 00910 - ADDENDA

END OF SECTION





**ADDENDUM #1**

Bid Number: #106-2017

Date: August 11, 2017

Subject: Expansion Area 3 Pump Station (Contract No.1)  
and Force Main (Contract No. 2) Improvements

Address inquiries to:  
Brian Marçum  
brianm@lexingtonky.gov  
(859) 258-3325

**TO ALL PROSPECTIVE SUBMITTERS:**

Please be advised of the following clarifications to the above referenced Bid:

**1. CLARIFICATIONS**

- a. The pre-bid meeting date has been changed to August 24<sup>th</sup>, 2017. For more details see specifications below.
- b. The pre-bid meeting is now mandatory.
- c. The last day to submit questions to purchasing has been changed to September 8<sup>th</sup>, 2017. For more details see specifications below.
- d. The bid submission and open date has been changed to September 21<sup>st</sup>, 2017. For more details see specifications below.

**2. SPECIFICATIONS**

- a. Section 00100, Advertisement for Bids, page 2: Article 1.08 **SUBMISSION OF BIDS** shall be deleted and replaced with the following:

**"Contractors shall submit their Bids to the Lexington-Fayette Urban County Government, Division of Purchasing, Third Floor, 200 East Main Street, Lexington, Kentucky 40507. Bids shall be submitted in a sealed envelope not later than 2:00 p.m. (local time) September 21, 2017. Sealed proposals shall be marked clearly on the outside of the container "Sealed Proposal for: Expansion Area 3 Pump Station (Contract No. 1) and Force Main (Contract No. 2) Improvements to be opened at 2:00 p.m. Local Time, September 21, 2017. Bids received after the scheduled closing time for receipt of Bids will not be considered and will be returned unopened."**





- b. Section 00100, Advertisement for Bids, page 3: Article 1.11 PRE-BID MEETING shall be deleted and replaced with the following:

"A Mandatory pre-Bid meeting will be held at 9:00 a.m. local time, August 24, 2017 at 125 Lisle Industrial Avenue, Tate Bldg. 1<sup>st</sup> Floor, Suite 18, Lexington, KY 40511."

- c. Section 00300, Information Available to Bidders, page 3: Article 1.09 ADDENDA AND INTERPRETATIONS shall be deleted and replaced with the following:

"No interpretation of the meaning of the Contract Documents will be made to any Bidder orally. Every request for such interpretation should be in writing addressed to the Director of Central Purchasing, in care of Brian Marcum at [brianm@lexingtonky.gov](mailto:brianm@lexingtonky.gov) (859) 258-3320, who in turn will have an addendum issued for the Lexington-Fayette Urban County Government, and to be given consideration must be received prior to close of business September 8th, 2017. Any and all such interpretations and any supplemental instructions will be in the form of written addenda to the specifications. Acknowledgement of the receipt of addenda must be included with all submitted Bids. Failure of any Bidder to receive any such addendum or interpretation shall not relieve such Bidder from any obligation under his Bid as submitted. All addenda so issued shall become part of the Contract Documents."

*Todd Slatin*

Todd Slatin, Director  
Division of Central Purchasing

All other terms and conditions of the Bid and specifications are unchanged.  
This letter should be signed, attached to and become a part of your Bid.

COMPANY NAME: \_\_\_\_\_

ADDRESS: \_\_\_\_\_

SIGNATURE OF BIDDER: \_\_\_\_\_



MAYOR JIM GRAY



LEXINGTON

TODD SLATIN  
DIRECTOR  
CENTRAL PURCHASING

**ADDENDUM #2**

Bid Number: #106-2017

Date: August 24, 2017

Subject: Expansion Area 3 Pump Station (Contract 1) and Force Main  
(Contract 2) Improvements

Address inquiries to:  
Brian Marcum  
(859) 258-3320

**TO ALL PROSPECTIVE SUBMITTERS:**

**Please be advised of the following clarifications to the above referenced bid:**

"The EPA forms *are* required to be completed with the bid documents. The subcontractor information must be included on the EPA forms".

**Attached find a list of MBE/DBE & Veteran Owned contractors to contact for this project.**

Todd Slatin, Director  
Division of Central Purchasing

All other terms and conditions of the RFP and specifications are unchanged. This letter should be signed, attached to and become a part of your submittal.

COMPANY NAME: \_\_\_\_\_

ADDRESS: \_\_\_\_\_

SIGNATURE OF BIDDER: \_\_\_\_\_







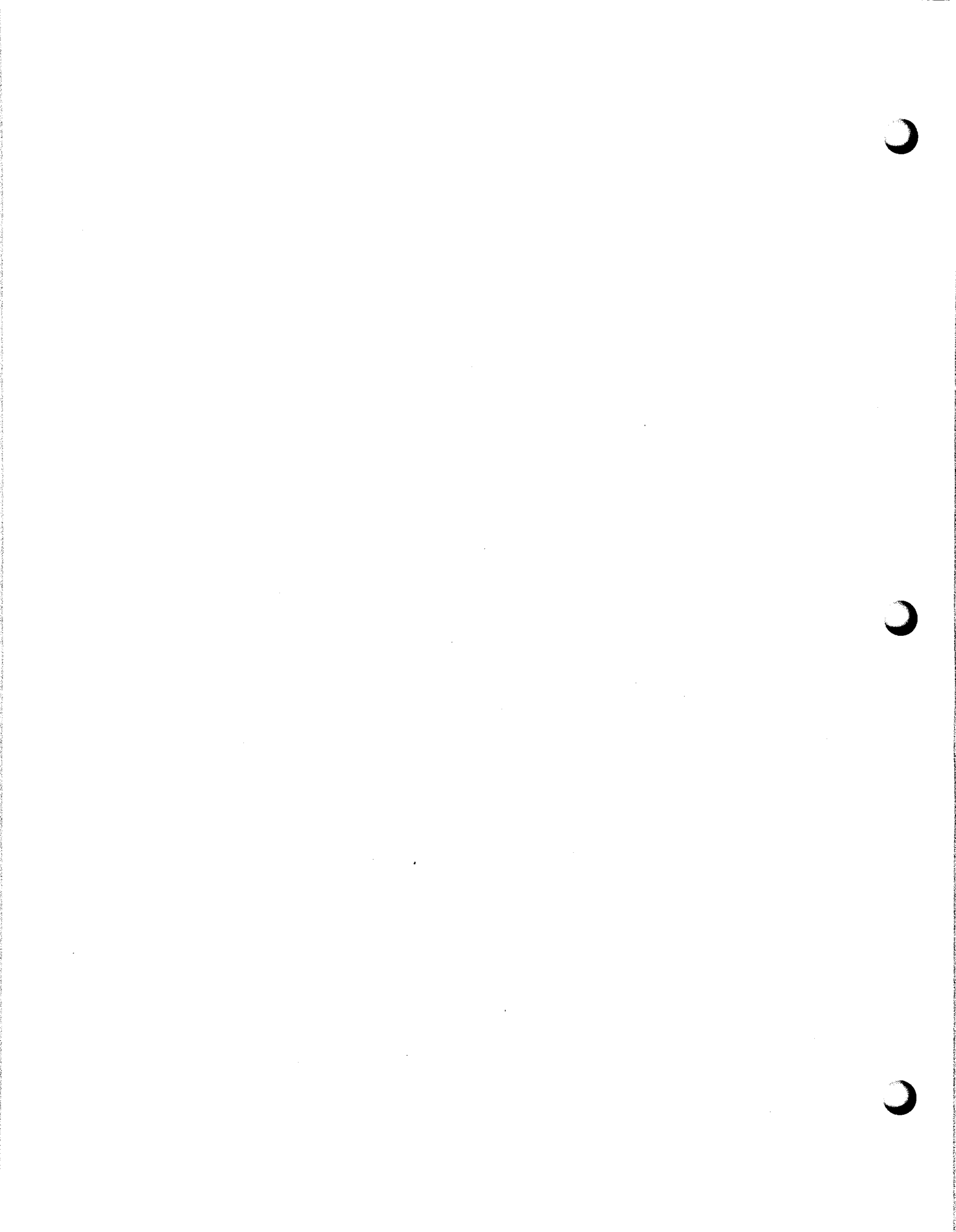



MAYOR JIM GRAY



**LEXINGTON**

TODD SLATIN  
DIRECTOR  
CENTRAL PURCHASING

**ADDENDUM #3**

Bid Number: #106-2017

Date: September 7, 2017

Subject: Expansion Area 3 Pump Station (Contract 1) and Force Main  
(Contract 2) Improvements

Address inquiries to:  
Brian Marcum  
(859) 258-3320

**TO ALL PROSPECTIVE SUBMITTERS:**

**Please be advised of the following clarifications to the above referenced bid:**

The question deadline has been extended to September 12, 2017 at 5:00 PM.

Todd Slatin, Director  
Division of Central Purchasing

All other terms and conditions of the RFP and specifications are unchanged. This letter should be signed, attached to and become a part of your submittal.

COMPANY NAME: \_\_\_\_\_

ADDRESS: \_\_\_\_\_

SIGNATURE OF BIDDER: \_\_\_\_\_



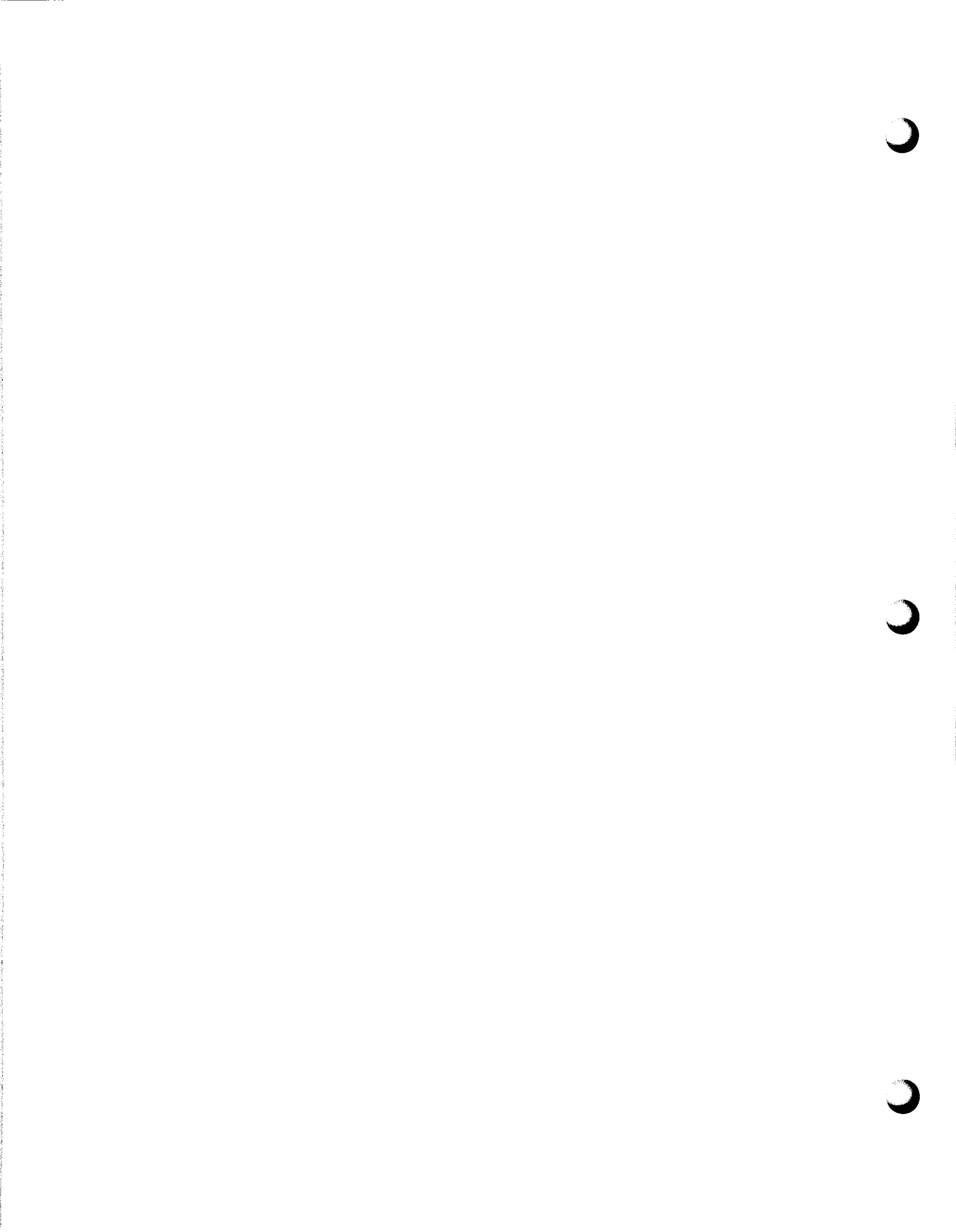

**ADDENDUM #4**Bid Number: #106-2017

Date: September 8, 2017

Subject: Expansion Area 3 Pump Station (Contract No. 1)  
and Force Main (Contract No. 2) ImprovementsAddress inquiries to:  
Brian Marcum  
[brianm@lexingtonky.gov](mailto:brianm@lexingtonky.gov)  
(859) 258-3325**TO ALL PROSPECTIVE SUBMITTERS:**

Please be advised of the following clarifications to the above referenced Bid:

**1. QUESTIONS****\*\*An excel spreadsheet will not be provided for bidding this project please use the bid forms.\*\***

	Questions	Answers
1.	Can a combine bid bond be provided for if bidding both contracts?	No. A separate bid bond is required for the largest bid amount for each contract bid. Two bid bonds are required if bidding both Contract No.1 and No. 2.
2.	What is the Contract No. 2 starting point?	Contract No. 2 starts at Sta. 10+00, erosion and sediment control shall start at Sta. 10+00.
3.	Can Huber Technology and Duperon be listed as an acceptable screen, screen compactor, and screen conveyor?	Contract No. 1 equipment manufacturers list has been revised as attached with the revised bid form to include: 1) Huber and Duperon have been added; 2) Other has been removed and will not be considered
4.	What are SRF Loan Funding wage rate, MBE/WBE, and AIS requirements?	SRF Loan Funding requires inclusion of Davis-Bacon wage rates, EPA MBE/WBE Good Faith Efforts, and American Iron and Steel (AIS) Provisions. Compliance with LFUCG's MBE/WBE Good Faith Efforts is required.



5.	What are Local Funding wage rate, MBE/WBE, and AIS requirements?	Local Funding does not require the use of Davis-Bacon wage rates, or American Iron and Steel (AIS) Provisions. Compliance with LFUCG's MBE/WBE Good Faith Efforts is required.
6.	What are the American Iron and Steel (AIS) Provisions versus Buy American requirements?	See Specification Section 00815 Guidance for the Implementation American Iron and Steel Provisions.
7.	What is the "ka" level for surge protection devices.	Surge Protection Devices shall have a 100kA minimum rating per attached revised Sheet 01E-02.
8.	What is the description of the power meter for the "MDP".	As part of the Addendum is a revised Specification Section 16441 – Switchboards.
9.	Is a 4 pole switch required for the automatic transfer switch?	No. Per specification Section 16496, Automatic Transfer Switch, paragraph 2.02.A.7, for 3-phase, 4-wire systems, the transfer switch shall have a solid neutral bus and therefore the transfer switch should be a 3-pole switch. Since the system does not have 277 volt requirements but the neutral is still required, paragraph 2.02.A.2 which calls for a 4-pole switch does not apply.
10.	Does the owner want a "switch neutral or an overlapping neutral"?	Switched neutral.
11.	Is the automatic transfer switch supposed to be a bypass switch type?	No.
12.	What is the basis of award for the projects?	The basis of award will be what is in the best interest of the city, looking at cash on hand, cost of KIA money and overhead.

## 2. CLARIFICATIONS

- A. Electrical layout work on Sheet 01E-09 shall coordinate exact location of water heater with plumbing design.
- B. The EA3 Pump Station specification Section 01010 Summary of Work shall include the wet well and valve vault.
- C. Contract time for Contract No. 1 is revised to 450 calendar days. Contract time for Contract No. 2 is revised to 270 calendar days.
- D. Contract No. 2 seed mixture for the UK Agriculture Farm shall be a mixture of KY31 Fescue (80%) and Perennial Rye grass (20%)
- E. All certificates of insurances shall name LFUCG and Hospice of the Bluegrass, Inc. as additional insured.



- F. Bidders for Contract No. 1 must complete the Bid Schedule (SRF Loan Funding) and Deductive Alternative (Local Funding) to be considered for Award.
- G. Bidders for Contract No. 2 must complete both Bid Schedules, SRF Loan Funding and Local Funding, to be considered for Award.
- H. Final restoration shall follow Non-paved Site Restoration as shown on Sheet 00G-04. Final payment shall not be made until completed.

### 3. DRAWINGS

- A. Sheet 01C-09, Access Road and Profile has been revised to include survey requirements, temporary fence, and Access Road entrance requirements. See attached.
- B. Sheet 01P-01, Plumbing Upper Plan has been revised to eliminate the instantaneous water heater in the restroom, pipe the lavatory from the heater, and add a thermostatic mixing valve at the restroom lavatory. See attached.
- C. Sheet 01P-02, Plumbing Schedule, Details and Notes has revised the requirements of the tank type water heater, add thermostatic mixing valve, and delete restroom instantaneous water heater from the fixture schedule. See attached.
- D. Sheet 01E-02, One-Line Diagram and Conduit Schedule has been revised to include Surge Protection Device rating. See attached.
- E. Sheet 00G-05, Project Specific Notes (Contract No. 2) Note 5 has been revised to include restoration requirements on UK Agricultural Farm. See attached.
- F. Sheet 01E-03, Panelboard Schedules has been revised to delete Circuit #22 and replace Circuit #26 with a 30A, 2-pole circuit breaker and #10 wire in ¾" conduit. See attached.

### 4. SPECIFICATIONS

- A. Sections 00410A, 00520A, and 00550A shall be revised to provide 450 calendar days to substantially complete work for Contract No.1.
- B. Sections 00410B, 00520B, and 00550B shall be revised to provide 270 calendar days to substantially complete work for Contract No. 2.
- C. Section 00410A, revised Bid Form is attached.
- D. Section 00410B, revised Bid Form is attached.
- E. Section 00600, Bonds and Certificates, Rick Management Provisions Insurance and Indemnifications, all certificates of insurance shall name LFUCG and Hospice of the Bluegrass, Inc. as additional insured.
- F. Section 01025, Measurement and Payment, EA3 Force Main (Contract No. 2) A5. shall be revised to provide "payment will be made at the Contact unit price per square yard for site restoration of the force main route for areas disturbed during construction."
- G. Section 01025, Measurement and Payment, EA3 Force Main (Contract No. 2) A6. shall be deleted. This item of work shall be miscellaneous to the force main unit price per linear foot.
- H. Section 01025, Measurement and Payment, EA3 Pump Station (Contract No. 1) B5. shall be revised to provide "payment will be made at the Contact unit price per square yard for site restoration of the gravity sewer route for areas disturbed during construction."



- I. Section 11421, Mechanical Screens and Screenings Compactors Duperon is attached.
- J. Section 16441, Switchboards shall be revised by adding Article 2.03 Digital Metering Device as follows:

**" 2.03 DIGITAL METERING DEVICE**

**A. General:**

- 1. Direct reading metered or calculated values.
- 2. Microprocessor based.
- 3. Integral LED or LCD display.
- 4. Current and potential transformers as required.
- 5. Integral fusing.
- 6. Operating temperature: 0 DEGF to 150 DEGF.
- 7. Standards:
  - a. NEMA/ANSI C12.20.
  - b. UL 508

**B. Type 'A' Low Range Meter:**

- 1. Display the following minimum electrical parameters (accuracy):
  - a. RMS current per phase (+0.3 PCT full scale).
  - b. RMS Voltage line-to-line and line-to-neutral (+0.3 PCT full scale).
  - c. Communication: Modbus
- 2. Supply voltage: 120 VAC.

**C. Unit to be Schneider ION6200 or equal."**

**5. GENERAL INFORMATION**

- A. Attached are the pre-bid meeting agenda, Erosion Control/SWPPP Requirements, and the pre-bid meeting sign-in-sheet for both contracts.



**Pre-Bid Meeting Agenda**

**Expansion Area 3 Pump Station (Contract No. 1) and**

**Force Main (Contract No. 2) Improvements**

**For**

**LFUCG – Division of Water Quality**

**Lexington, Kentucky**

**August 24, 2017**

**9:00 a.m. (local time)**

**I. Introduction / Sign In**

- LFUCG – Division of Water Quality(Owner)
- HDR Engineering, Inc.
- TetraTech
- Hazen and Sawyer

**II. Project Description**

- Contract No. 1 – Class A Pumping Station with mechanical screens, screen compactors, four (4) submersible pumps, odor control equipment, building with screen room, dumpster room, odor control room, electrical room, and emergency generator. Also, approximately 220 LF of 24" force main and 660 LF of 10" gravity sanitary sewer.
- Contract No. 2 – 5,550 LF of 24" PVC force main, 300 LF of 48" steel casing pipe bored and jacked under I-64/I-75.
- Contract No. 1 is required to make the final connection of the 24" force main at Station 10+00 located near the property line between the pump station and Hospice properties.

**III. Storm Water Management**

- Erosion Control/SWPPP Requirements (Richard Walker, TetraTech)

**IV. MWDBE Participation Goals**

- MWDBE Goal (Sherita Miller, Purchasing)

**V. Bid Format / Procedure**

**A. General Information (Brian Marcum, Purchasing)**

- Bid are due September 21, 2017, 2:00 p.m. (local time)



- Location: Lexington-Fayette Urban County Government (LFUCG)  
Division of Purchasing, Third Floor  
200 East Main Street  
Lexington, KY 40507
  - Bid questions and answer deadline is September 8, 2017 @ COB. Submit questions to Brian Marcum at [brianm@lexingtonky.gov](mailto:brianm@lexingtonky.gov).
  - Basis of award.
  - Any Bid from Bidder not recorded as a Plan Holder may not be considered and returned unopened.
  - Bid Security amount of 5 percent is required (Section 00300, Article 1.05)
- B. Time for Completion/Liquidated Damage
- Substantial Completion: Contract No. 1 within 450 calendar days; Contract No. 2 within 270 calendar days. These times are different than the bid documents, and will be modified via addendum.
  - Project Closeout – As set forth in Section 01770 - Project Closeout
  - Liquidated Damages:  
\$800/Day for failure to meet Final Completion
- C. Funding/Labor Requirements
- SRF/KIA or Local Funding (to be determined before contract award)
  - Federal (Davis Bacon) Wage Rates Apply if SRF/KIA funded
  - Buy America Provisions (AIS) if SRF/KIA funded
- D. Other
- Section 00410A (Contract No. 1) and Section 00410B (Contract No. 2) – Bid Forms (requested additional information)
  - Allowances for each contact
  - Deductive Alternative for Contract No. 1. Contract No. 2 shall have two bid schedules, one for KIA funding (with David-Bacon wage rates) and one for local funding (no wage rates).

## VI. Work Issues / Comments

- A. Access to work areas
- B. Easement requirements/MOU Conditions
- C. Site restoration
- D. General Notes
- E. Project specific notes (see Sheets 00G-05 and SS1.0)





F. Coordination between contractors

G. Communication with property owners shall be routed through the Engineer

H. No disturbance to Dr. Poole's property is allowed (adjacent to access road)

I. Other

**VII. Miscellaneous**

A. Contract Documents – Lynn Imaging, 328 Old Vine Street, Lexington, KY 40507 ([www.lynnimaging.com](http://www.lynnimaging.com))

**VIII. Questions / Closing Remark / Site Visit**

A. Site visit directly after pre-bid meeting. Any other visits to the site prior to bid must be coordinated with Engineer.

**Permitting, Inspection, and Enforcement Procedures for  
Erosion and Sediment Control on Capital Projects  
Division of Water Quality Remedial Measures Plan (RMP)**

RMP Program Manager: Vernon Azevedo  
RMP Project Managers: Kevin Levesque  
RMP Administrative Specialist Principal: Diann Williams  
Construction Contract Administrators (CA): DWQ Consultants  
Resident Project Representatives (RPR): DWQ Consultants  
ESC Plan Reviewer: DWQ Stormwater Section – Amad AL-Humadi  
ACCELA Data Entry: DWQ Compliance and Monitoring – Kevin Lyne  
Permittee: Contractor

**Permitting Procedures**

1. Contractor shall develop a Stormwater Pollution Prevention Plan / Erosion and Sediment Control Plan (SWPPP/ESC Plan).  
  
On some projects, the construction contract documents may contain a SWPPP/ESC Plan prepared by LFUCG's staff engineer or consultant for purposes of establishing bid quantities. If the Contractor chooses to use this SWPPP/ESC Plan to obtain the required permits, the Contractor takes sole responsibility for the content of the SWPPP/ESC Plan and the implementation of the SWPPP during construction.
2. Contractor must submit an application for a Land Disturbance Permit to the LFUCG Division of Engineering before beginning project construction. A permit application is on the LFUCG website at <https://www.lexingtonky.gov/new-development>.
3. Contractor must submit a Notice of Intent (NOI) to the KY Division of Water (KDOW) and obtain KYR10 Permit coverage before beginning construction of any kind on the site. The NOI can be submitted electronically at:  
<http://dep.ky.gov/formslibrary/Documents/KYR10PermitPage.pdf>.
4. Contractor cannot start project work until they have obtained the LFUCG Land Disturbance Permit and KYR10 Permit coverage. In addition, Contractor will be required to post an ESC Performance Bond before starting construction. (Note: ESC will be bid as lump sum. The value of the bond will be equal to the lump sum amount.)
5. Amad AL-Humadi reviews the SWPPP/ESC Plan, confirms that the Contractor has obtained KYR10 Permit coverage, and authorizes the Contractor to install the initial BMPs.
6. Amad AL-Humadi inspects the installation of the initial BMPs and authorizes DOE to issue the LFUCG Land Disturbance Permit.

## Contractor Responsibilities

Contractor shall:

1. Attend a pre-construction conference with LFUCG.
2. Post the LFUCG Land Disturbance Permit and KYR10 Permit on the project sign at the site.
3. Follow the SWPPP/ESC Plan; revise and redline it as conditions change on the site.
4. Install and maintain BMPs to prevent sediment from washing into streets, storm sewers, and streams.
5. Conduct an ESC inspection at least once every 7 calendar days and within 24 hours after each rainfall event of 0.5 inches or greater (or a snow event of 4 inches or greater).
6. Complete an inspection form after each inspection.
7. Stabilize the site within 14 days after reaching temporary or final grade.
8. Maintain a 50-foot vegetative buffer strip along streams, wetlands, sinkholes, and inlets.
9. If work must be done within 50 feet of a stream, wetland, sinkhole, or inlet, complete work as soon as possible and stabilize the area within 24 hours after completing work.
10. File a Notice of Termination with the KY Division of Water, LFUCG Division of Engineering, and LFUCG Division of Water Quality when final stabilization has been achieved. Final stabilization is defined as follows from KYR10:  

"All soil disturbing activities at the site have been completed and either of the two following criteria are met:

  - a. a uniform(e.g., evenly distributed, without large bare areas) perennial vegetative cover with a density of 70 percent of the native background vegetative cover for the area has been established on all unpaved areas and areas not covered by permanent structures, or
  - b. equivalent stabilization measures (such as the use of riprap, gabions, or geotextiles) have been employed."
11. Respond promptly to Verbal Warnings from LFUCG regarding correcting ESC problems.

## Inspection Procedures of the RPR

### RPR Monthly Field Inspection (two times a month if crossing a stream or in a floodplain)

1. Ensure the LFUCG Land Disturbance Permit and KYR10 Permit are posted at the site
2. Ensure ESC Plan and SWPPP are available for review
3. Ensure Contractors' weekly inspection forms are available for review
4. Walk the perimeter of the entire site
5. Note downgradient controls
  - Inspect silt fences, culvert/ditch outlets
  - Significant sediment discharges?
6. Walk around internal disturbed areas
  - Idle for more than 14 days . . . stabilized?
7. Inspect all inlets and ditches
  - Inlets protected, ditches stabilized?
8. Check out material/fuel storage areas
  - Spills? Leaks? Leaching pollutants?
9. Inspect concrete washout(s)
10. Inspect the construction entrance/exit
11. Inspect the vegetated buffer strip adjacent to streams (no disturbance allowed)
12. Complete the LFUCG monthly inspection checklist. Submit an electronic copy of the completed checklist to Kevin Lyne, the RMP Project Manager, and Diann Williams. Kevin will enter it into ACCELA.
13. Inspect the site the next working day after a storm event of 0.5 inches or greater and complete the inspection checklist. Submit a copy to the RMP Project Manager and Diann Williams.

### Important things for the RPR to look for:

- Posted permits, plans, and inspection reports
- Graded areas stabilized with seed, mulch, blankets, mats, etc.
- Stabilized ditches
- Maintenance on silt fences and curb/drop inlets
- No mud on the street
- Trash and litter managed
- No disturbance in 50-foot buffer zone adjacent to streams, wetlands, sinkholes, and inlets, unless stabilized within 24 hours.

## Enforcement Procedures

1. The Contractor will be paid for erosion and sediment control based upon a schedule of values established within the Measurement and Payment section of the specifications (e.g. 25% paid once initial ESCs have been installed and LDP obtained, 50% paid in equal monthly payments for maintenance over the construction period, 25% paid for removal of ESCs and final stabilization). The intent of this provision is to pay the Contractor for monthly ESC maintenance only if the BMPs are functioning properly.
2. When the RPR identifies ESC deficiencies, the RPR shall issue a verbal warning to the Contractor to address the deficiencies. If the deficiencies are not addressed after two verbal warnings, the RPR shall notify the RMP Contract Administrator of the deficiencies. In some cases, the RMP Contract Administrator should be notified immediately. Refer to the attached Compliance Assistance Guidance for RPRs.
3. The RMP Contract Administrator shall prepare a written summary of the deficiencies referred by the RPR, and shall notify the RMP Project Manager that additional enforcement measures are needed to achieve compliance.
4. The RMP Project Manager shall use all available means in the contract to obtain compliance, including:
  - a. stopping work
  - b. withholding payment
  - c. notifying the Contractor that LFUCG intends to initiate the process for declaring that the Contractor is in default of the contract and specifying a deadline for addressing the ESC deficiencies
  - d. initiating the process for calling the ESC Performance Bond
  - e. issuing NOVs

### Compliance Assistance Guidance for RPRs on RMP Projects

Observed Condition	Verbal Warning to Correct within 3-5 days	Verbal Warning to Correct within 24 hours (See Note 1)	Notify RMP Contract Administrator Immediately
Construction Entrance to Public Road	Rock pad poorly installed/maintained	Rock pad not installed	
	Small amount of sediment on road	Rock pad completely covered with soil	
Unstabilized Areas	Flat inactive disturbed areas not stabilized in 14 days	Significant amount of sediment on road	
		Ditches not stabilized immediately after construction	
Inlet Protection		Disturbed, inactive slopes not stabilized within 14 days	Disturbed, inactive slopes above waterways, wetlands, floodplains, critical areas not stabilized within 24 hours
	Sediment needs to be removed around inlet protection	Curb inlet protection not in place or improperly installed	Discharge of concrete wash water, chemicals, other pollutants into inlets, streams, wetlands, etc.
Silt Fencing	Does not match ESC Plan but critical areas and roads are protected	Silt fence not installed per plan	
	Does not comply with Stormwater Manual but is functional	Blowouts have occurred with discharge of sediment to critical areas	
Soil Stockpiles	Needs maintenance/repair, but is not near an inlet or surface water	Not trenched in, is not functional	
	No perimeter controls, downstream BMPs in place	Needs repaired in critical areas	
Permit Violations		No perimeter controls, downstream BMPs not in place	
		Permit expired	Site not permitted
		Permit not posted or available on site	
		Contact name/phone not posted	
		No self-inspection reports; reports not on site	
		Self-inspection reports not current	
		ESC Plan / SWPPP not on site	
	Minor unapproved construction activities in 50-foot buffer zone around sinkholes, streams, wetlands, etc.	Major unapproved construction activities in 50-foot buffer zone around sinkholes, streams, wetlands, etc.	

1. Refer issue to RMP Contract Administrator after 2nd Verbal Warning
2. Critical areas are streams, wetlands, sinkholes, and inlets

Expansion Area 3 Pump Station Improvements  
(Contract No.1)  
LFUCG – Division of Water Quality  
Lexington, Kentucky

Mandatory Pre-Bid Meeting Sign-In Sheet  
August 24, 2017 at 9:00 a.m.

Name	Company Represented	Phone Number
Barton Hanson	HDR Eng.	859-629-4800
BISHOP CARTER IV	EMANUE ALLEN LLC	859 221 1563
Shane Paxter	Building Crafts, Inc.	859-701-9500
John Kraft	MAC Construction	812-725-4146
Tom HARRAH	Tribute Contracting	740-451-1010
Kerry Smith	Smith Contractors	502-839-4196
Kenin Cassidy	Norris Bros. Excavating	931-277-5665
Freddie Comp	Connhurst, LLC	606-286-0387
Carl Schroedel	Schroedel Construction	270-357-7717
BRIAN BILLINGS	ATS CONSTRUCTION	859 223-1001
KURT Zehnder	HAZEN and SAWYER	859.286.1265
Richard Walker	Tetra Tech	859-514-8749
Vernon Ayewelo	DWG	859.425.2438
Darren Cleary	Cleary Const. Inc	270-487-1784
MARK POMBOVSKY	THIENEMAN CONSTRUCTION	317-967-3462
STEVE Judy	Judy Construction Co.	859 234 6900
BEN Williams	Judy Const Co	859 236-4900
Shannon Hubert	Hubert Excavating & Cont.	502-680-0759
MAURICE S. ZAW	BRACKNEY INC	765 687 6551
Douglas Medema	W ROGERS COMPANY	859-410-7221
BOYD ROGERS	W. ROGERS COMPANY	859-410-7220
Jerry Wilson	Todd Johnson Contracting, Inc.	859-326-0325

Expansion Area 3 Pump Station Improvements  
 (Contract No.1)  
 LFUCG – Division of Water Quality  
 Lexington, Kentucky

Mandatory Pre-Bid Meeting Sign-In Sheet  
 August 24, 2017 at 9:00 a.m.

Name	Company Represented	Phone Number
Mike Mulhall	Pace Contracting	502-471-1158
Robert Weber	Allied pump Rentals	513-407-2403
Richard Younger	Younger Electric	502-863-3046
Jim Pelton	Pelton Env.	773-428-4499
Eric Deaton	Davis Industrial Construction Co.	937-479-2908
DYLAN MURPHY	ATS CONSTRUCTION	859-223-7001
Tom Colley	CJ Hughes Const	304-399-2313
Coac Terry	J. Lumby Construction	931-526-5158
Chris Webb	Ferguson WW	859-302-5075
Braed Shouse	T.E.M. Elect.	859-229-4873
Kyle Rabe	Dugan & Meyers LLC	513-678-0254
Rob Hill	MARTIN CONTRACTING	859-324-0389
ALLAN FARRIS	MARTIN CONTRACTING	606-305-4283
SHERIE MILLER	LFUCG PURCHASING	(859) 258-3323
Primo Mancini	LFUCG	258-3322
Jon Sentenest	HAFGEN AND STUYVER	(859) 219-1126



Expansion Area 3 Force Main Improvements  
(Contract No.2)  
LFUCG - Division of Water Quality  
Lexington, Kentucky

Mandatory Pre-Bid Meeting Sign-In Sheet  
August 24, 2017 at 9:00 a.m.

Name	Company Represented	Phone Number
Barton Hanson	HDR Eng.	857-629-4800
BISHOP CARTER	EXAMINE ALDEN LLC	859-221-1563
Joe Finley	Twin States Utilities	270-427-0710
CHRIS ADAMS	TWIN STATES UTILITIES	270-407-8366
Shane Paxon	Building Credits, Inc	859-781-9500
John Kraft	MAC Construction	812-725-4146
TODD HARRAH	Tribute Contracting	740-451-1010
Kerry Smith	Smith Contractors	502-839-4196
Kevin Cassidy	Norris Bros. Excavating	931-277-5665
Freddie Conn	Connhurst, LLC.	606-286-0387
MARK DOMBROSKY	THREEMAN CONSTRUCTION	270-967-3462
Kael Schroeder	Schroeder Contracting, Inc	270-737-7777
BRIAN BILLINGS	ATS CONSTRUCTION	859-327-4533
KURT Zehnder	HAZEN and SAWYER	859.286.1265
Darren Clesry	Clesry Const Inc.	270-487-1784
Vernon Aywede	DWA	859-425-2438
Dawn Hobbes	W. ROBERTS	859-231-6290
Gage Terry	J. Comby Construction	931-526-5158
Harold Skaggs	M Ke ENYART & Sons	740-646-6215
Tom Colley	CI Hughes CONST	304-399-2313
DYLAN MURPHY	ATS CONSTRUCTION	859-223-7001
RHONDA FISTER	FREE CONTRACTING, INC.	859-621-6420

Expansion Area 3 Force Main Improvements  
 (Contract No.2)  
 LFUCG – Division of Water Quality  
 Lexington, Kentucky

Mandatory Pre-Bid Meeting Sign-In Sheet  
 August 24, 2017 at 9:00 a.m.

Name	Company Represented	Phone Number
Mike Mathall	Pace Contracting	502-471-1158
Robert Weber	Allied Pump Rentals	513-467-2483
Chris Webb	Ferguson WH	859-302-5075
Brad Shouse	T.E.M. Elect.	859-229-4873
Kyle Rabe	Dugan & Meyers LLC	513-678-0254
Rob Hill	MARTIN CONTRACTING	859-324-0329
ALLAN FARRIS	MARTIN CONTRACTING	606-305-4283
Ben Williams	Judy Const Co	859-234-6900
Shannon Hubert	Hubert Excavating	502-680-0759
NATHAN TURTLE	B A ACK W C Y T W C	765-647654
Jeremy Johnson	Todd Johnson Contracting, Inc.	859-286-0335
Rob Harris	Nixon Power Services	802-777-8274
Jon Senterbart	Hazen and Sawyer	859 219 1126

SECTION 00410A – BID FORM

Expansion Area 3 Pump Station Improvements (Contract No. 1)

Division of Water Quality  
Lexington-Fayette Urban County Government

LFUCG Bid No. 160-2017

1.01 GENERAL

Place: Lexington, Kentucky

Date: \_\_\_\_\_

The following Bid Form shall be followed exactly in submitting a Bid for this Work.

This Bid Form Submitted by \_\_\_\_\_  
\_\_\_\_\_  
(Name and Address of Bidder)

(Hereinafter called "Bidder"), organized and existing under the laws of the State of \_\_\_\_\_, doing  
business as \_\_\_\_\_  
"a corporation," "a partnership", or an "individual" as applicable

To: Lexington-Fayette Urban County Government  
(Hereinafter called "Owner")  
Office of the Director of Central Purchasing  
200 East Main Street, Room 338  
Lexington, KY 40507

The Bidder, in compliance with your Advertisement for Bids for the **Expansion Area 3 Pump Station Improvements (Contract No. 1)**; Lexington, Kentucky, having examined the Contract Documents including the Plans and Specifications with related documents, having examined the site for proposed Work, and being familiar with all of the conditions and any and all addendums surrounding the construction of the proposed Project, including the availability of materials and labor, hereby proposes to furnish all labor, materials, and supplies, and to construct the Project in accordance with the Contract Documents, within the time set forth therein, and at the lump sum stated hereinafter. These prices are to cover all expenses incurred in performing the Work required under the Contract Documents, of which this Bid is a part. This bid includes the Pump Station, Pump Station site work and access road.

The Bidder hereby agrees to commence Work under this Contract on a date to be specified in a written "Notice to Proceed" of the Owner and to substantially complete the Project within 450 consecutive calendar days. Bidder further agrees to pay liquidated damages, the sum of eight hundred dollars and no cents (\$800.00) for each consecutive day thereafter.

The Bidder hereby acknowledges receipt of the following addenda:

Addendum No. \_\_\_\_ Date \_\_\_\_\_;      Addendum No. \_\_\_\_ Date \_\_\_\_\_  
Addendum No. \_\_\_\_ Date \_\_\_\_\_;      Addendum No. \_\_\_\_ Date \_\_\_\_\_  
Addendum No. \_\_\_\_ Date \_\_\_\_\_;      Addendum No. \_\_\_\_ Date \_\_\_\_\_  
Addendum No. \_\_\_\_ Date \_\_\_\_\_;      Addendum No. \_\_\_\_ Date \_\_\_\_\_

Insert above the number and the date of any Addendum issued and received. If none has been issued and received, the word "NONE" should be inserted.

**1.02 LEGAL STATUS OF BIDDER**

Bidder \_\_\_\_\_

Date \_\_\_\_\_

\*A. A corporation duly organized and doing business under the laws of the State of \_\_\_\_\_,  
for whom \_\_\_\_\_, bearing the  
official title of \_\_\_\_\_, whose signature is  
affixed to this Bid is duly authorized to execute contracts.

\*B. A Partnership, all of the members of which, with addresses are: (Designate general partners  
as such)

\_\_\_\_\_  
\_\_\_\_\_  
\_\_\_\_\_  
\_\_\_\_\_  
\_\_\_\_\_

\*C. An individual, whose signature is affixed to this Bid. (Print name)

\_\_\_\_\_  
\_\_\_\_\_  
\_\_\_\_\_

\* The Bidder shall fill out the appropriate form and strike out the other two.

1.03 BIDDERS AFFIDAVIT

Comes the Affiant, \_\_\_\_\_, and after being first duly sworn, states under penalty of perjury as follows:

- A. His/her name is \_\_\_\_\_ and he/she is the individual submitting the Bid or is the authorized representative of \_\_\_\_\_, the entity submitting the Bid (hereinafter referred to as "Bidder").
- B. Bidder will pay all taxes and fees, which are owed to the Lexington-Fayette Urban County Government at the time the Bid is submitted, prior to award of the Agreement and will maintain a "current" status in regard to those taxes and fees during the life of the Agreement.
- C. Bidder will obtain a Lexington-Fayette Urban County Government business license, if applicable, prior to award of the Agreement.
- D. Bidder has authorized the Division of Central Purchasing to verify the above-mentioned information with the Division of Revenue and to disclose to the Urban County Council that taxes and/or fees are delinquent or that a business license has not been obtained.
- E. Bidder has not knowingly violated any provision of the campaign finance laws of the Commonwealth of Kentucky within the past five (5) years and the award of an Agreement to the Bidder will not violate any provision of the campaign finance laws of the Commonwealth.
- F. Bidder has not knowingly violated any provision of Chapter 25 of the Lexington-Fayette Urban County Government Code of Ordinances, known as the "Ethics Act."
- G. Bidder acknowledges that "knowingly" for purposes of this Affidavit means, with respect to conduct or to circumstances described by a statute or ordinance defining an offense, that a person is aware or should have been aware that his/her conduct is of that nature or that the circumstance exists.

Further, Affiant sayeth naught.

\_\_\_\_\_  
Affiant Signature

STATE OF \_\_\_\_\_

COUNTY OF \_\_\_\_\_

The foregoing instrument was subscribed, sworn to and acknowledged before me by

\_\_\_\_\_ on this the \_\_\_\_\_ day of \_\_\_\_\_, 20\_\_\_\_.

My Commission expires: \_\_\_\_\_

\_\_\_\_\_  
NOTARY PUBLIC, STATE AT LARGE

**1.04 BID SCHEDULE**

The Bidder agrees to perform all the Work described in the Specifications and shown on the Plans for the following proposed lump sum, which shall include the furnishing of all labor, materials, supplies, equipment and/or vehicle usage, services, all items of cost, overhead, taxes (federal, state, local), and profit for the Contractor and any Subcontractor involved, within the time set forth herein. If unit prices are applicable, Bidder must make the extensions and additions showing the total amount of Bid. In all cases of discrepancies or math errors the amount written in for the unit price of an item shall govern.

If a lump sum total price is illegible or is omitted, the bid may be determined nonresponsive.

For a lump sum based bid, the item total is the bid amount the Owner uses for bid comparison.

The Owner's decision on the bid amount is final.

**Contractor shall complete the bid schedule and deductive alternative.**

**EA3 PUMP STATION BID SCHEDULE (Contract No. 1)<sup>1</sup> (SRF Loan Funding)**

<b>B. EA3 Pump Station:</b>					
B1	Base Bid for Construction of the EA3 Pump Station per the Contract Documents, Exclusive of the Following Items	1	LS	\$	\$
B2	10-inch Sanitary Sewer	662	LF	\$	\$
B3	4-foot Diameter Manhole	3	EA	\$	\$
B4	4-foot Diameter Drop Manhole	1	EA	\$	\$
B5	Gravity Sewer Site Restoration: Method B	3,800	SY	\$	\$
<b>C. Allowances:</b>					
C1	Control Touch SCADA Integration	1	EA	\$50,000	\$50,000
C2	Project Video Monitoring	1	EA	\$11,000	\$11,000
C3	Miscellaneous Site Improvements	1	EA	\$500,000	\$500,000
C4	Emergency Generator Fuel Tank Permit	1	EA	\$200	\$200
C5	Electrical Service	1	EA	\$10,000	\$10,000
C6	Water Service	1	EA	\$6,000	\$6,000
<b>TOTAL BID (Items B thru C)</b>					

Note: <sup>1</sup> Total Bid (Items B thru C) shall be based on a SRF loan which includes Davis-Bacon wage rates, Good Faith Efforts per EPA requirements, and all American Iron and Steel (AIS) provisions.

**TOTAL BID AMOUNT:**

\_\_\_\_\_ Dollars (\$ \_\_\_\_\_)

**DEDUCTIVE ALTERNATE <sup>1</sup> (Local Funding):**

\_\_\_\_\_ Dollars (\$ \_\_\_\_\_)

**Note:** <sup>1</sup> Deductive Alternate is the amount of difference between the Bid amount **with** Davis Bacon wage rates Good Faith Efforts, AIS provisions and the amount **without** Davis Bacon wage rates, Good Faith Efforts, and AIS provisions.

Respectfully Submitted,

FIRM: \_\_\_\_\_

ADDRESS: \_\_\_\_\_

CITY/STATE/ZIP: \_\_\_\_\_

DATE: \_\_\_\_\_

BY: \_\_\_\_\_  
(must be original signature)

TITLE: \_\_\_\_\_

PHONE: \_\_\_\_\_ FAX: \_\_\_\_\_  
(area code, number & extension)

EMAIL ADDRESS: \_\_\_\_\_

**OFFICIAL ADDRESS AND PHONE:**

\_\_\_\_\_

\_\_\_\_\_

\_\_\_\_\_ (Seal if Bid is by Corporation)

By signing this form you agree to all of the terms and associated forms.

**1.05 STATEMENT OF BIDDER'S QUALIFICATIONS**

The following statement of the Bidder's qualifications is required to be filled in, executed, and submitted with the Bid:

- A. Name of Bidder: \_\_\_\_\_
- B. Permanent Place of Business: \_\_\_\_\_
- C. When Organized: \_\_\_\_\_
- D. Where Incorporated: \_\_\_\_\_
- E. Financial Condition: \_\_\_\_\_

If specifically requested by the Owner, the apparent low Bidder is required to submit its latest three (3) years audited financial statements to the Owner's Division of Central Purchasing within seven (7) calendar days following the Bid opening.

- F. In the event the Agreement is awarded to the undersigned, Performance, Payment, Erosion and Sediment Control, and Warranty bonds will be furnished by:

\_\_\_\_\_ (Surety)

Signed: \_\_\_\_\_ (Representative of Surety)

- G. The following is a list of similar projects performed by the Bidder: (Attach separate sheet if necessary).

<u>NAME</u>	<u>LOCATION</u>	<u>CONTRACT SUM</u>
_____	_____	_____
_____	_____	_____
_____	_____	_____
_____	_____	_____
_____	_____	_____

- H. The Bidder has now under contract and bonded the following projects:

<u>NAME</u>	<u>LOCATION</u>	<u>CONTRACT SUM</u>
_____	_____	_____
_____	_____	_____
_____	_____	_____
_____	_____	_____
_____	_____	_____



I. List Key Bidder Personnel who will work on this Project.

<u>NAME</u>	<u>POSITION DESCRIPTION</u>	<u>NO. OF YEARS WITH BIDDER</u>
_____	_____	_____
_____	_____	_____
_____	_____	_____
_____	_____	_____
_____	_____	_____

J. MWDBE Participation on current bonded projects under contract:

<u>SUBCONTRACTORS (LIST)</u>	<u>PROJECT (SPECIFIC TYPE)</u>	<u>MWDBE</u>	<u>% of WORK</u>
_____	_____	_____	_____
_____	_____	_____	_____
_____	_____	_____	_____
_____	_____	_____	_____
_____	_____	_____	_____
_____	_____	_____	_____
_____	_____	_____	_____

(USE ADDITIONAL SHEETS IF NECESSARY)

K. We acknowledge that, if we are the apparent low Bidder, we may be required to submit to the Owner within seven (7) calendar days following the Bid Opening, a sworn statement regarding all office management and field management personnel. Additionally, if requested by the Owner, we will within seven (7) days following the request submit audited financial statements and loss history for insurance claims for the three (3) most recent years (or a lesser period if stipulated by the Owner)

**1.06 LIST OF PROPOSED SUBCONTRACTORS**

The following list of proposed subcontractors is required by the Owner to be executed, completed and submitted with the Bid Form. All subcontractors are subject to approval of the Lexington-Fayette Urban County Government. Failure to submit this list completely filled out may be cause for rejection of Bid.

<u>BRANCH OF WORK**</u> (List each major item)	<u>SUBCONTRACTOR</u>	<u>MWDBE (yes/no)</u>	<u>% of WORK</u>
1. _____	Name: _____	_____	_____
	Address: _____		
	_____		
2. _____	Name: _____	_____	_____
	Address: _____		
	_____		
3. _____	Name: _____	_____	_____
	Address: _____		
	_____		
4. _____	Name: _____	_____	_____
	Address: _____		
	_____		
5. _____	Name: _____	_____	_____
	Address: _____		
	_____		
6. _____	Name: _____	_____	_____
	Address: _____		
	_____		

\*\* Such as: Grading, bituminous paving, concrete, seeding and protection, construction staking, etc.

**1.07 AUTHENTICATION OF BID AND STATEMENT OF NON-COLLUSION AND NON-CONFLICT OF INTEREST**

I hereby swear (or affirm) under the penalty for false swearing:

- A. That I am the Bidder (if the Bidder is an individual), a partner of the Bidder (if the Bidder is a partnership), or an officer or employee of the Bidding corporation having authority to sign on its behalf (if the Bidder is a corporation);
- B. That the attached Bid has been arrived at by the Bidder independently, and has been submitted without collusion with, and without any agreement, understanding or planned common course of action, with any other contractor, vendor of materials, supplies, equipment or services described in the Advertisement for Bid, designed to limit independent bidding or competition;
- C. That the contents of the Bid or Bids have not been communicated by the Bidder or its employees or agents to any person not an employee or agent of the Bidder or its surety on any bond furnished, with the Bid or Bids, and will not be communicated to any such person, prior to the official opening of the Bid or Bids;
- D. That the Bidder is legally entitled to enter into the contracts with the Lexington-Fayette Urban County Government, and is not in violation of any prohibited conflict of interest;
- E. (Applicable to corporation only) That as a foreign corporation, we are registered with the Secretary of State, Commonwealth of Kentucky, and authorized to do business in the State \_\_\_\_\_ or, that as a domestic corporation, we are in good standing with the Secretary of State, Commonwealth of Kentucky \_\_\_\_\_. [Check the statement applicable.]
- F. This offer is for ninety (90) calendar days from the date this Bid is opened. In submitting the above, it is expressly agreed that, upon proper acceptance by the Lexington-Fayette Urban County Government of any or all items Bid above, an Agreement shall thereby be created with respect to the items accepted.
- G. That I have fully informed myself regarding the accuracy of the statements made in this statement.
- H. That I certify that Subcontractors have not and will not be awarded to any firm(s) that have been debarred from noncompliance with the Federal Labor Standards, Title VI of the Civil Rights Act of 1964 As Amended, Executive Order 11246 As Amended or any other Federal Law.

\_\_\_\_\_  
Company

\_\_\_\_\_  
Date

\_\_\_\_\_  
Representative

**1.08 STATEMENT OF EXPERIENCE**

NAME OF INDIVIDUAL: \_\_\_\_\_

POSITION/TITLE: \_\_\_\_\_

STATEMENT OF EXPERIENCE: \_\_\_\_\_

\_\_\_\_\_

NAME OF INDIVIDUAL: \_\_\_\_\_

POSITION/TITLE: \_\_\_\_\_

STATEMENT OF EXPERIENCE: \_\_\_\_\_

\_\_\_\_\_

NAME OF INDIVIDUAL: \_\_\_\_\_

POSITION/TITLE: \_\_\_\_\_

STATEMENT OF EXPERIENCE: \_\_\_\_\_

\_\_\_\_\_

NAME OF INDIVIDUAL: \_\_\_\_\_

POSITION/TITLE: \_\_\_\_\_

STATEMENT OF EXPERIENCE: \_\_\_\_\_

\_\_\_\_\_

\* Include all officers, office management, Affirmative Action officials, and field management personnel.  
Attach separate sheets if necessary.

## 1.09 EQUAL OPPORTUNITY AGREEMENT

### The Law

- \* Title VII of the Civil Rights Act of 1964 (amended 1972) states that it is unlawful for an employer to discriminate in employment because of race, color, religion, sex, age (40-70 years) or national origin.
- \* Executive Order No. 11246 on Nondiscrimination under Federal contract prohibits employment discrimination by contractor and subcontractor doing business with the Federal Government or recipients of Federal funds. This order was later amended by Executive Order No. 11375 to prohibit discrimination on the basis of sex.
- \* Section 503 of the Rehabilitation Act of 1973 States:

*The Contractor will not discriminate against any employee or applicant for employment because of physical or mental handicap.*
- \* Section 2012 of the Vietnam Era Veterans Readjustment Act of 1973 requires Affirmative Action on behalf of disabled veterans and veterans of the Vietnam Era by contractors having Federal Contracts.
- \* Section 206 (A) of Executive Order 12086, Consolidation of Contract Compliance Functions for Equal Employment Opportunity, states:

*The Secretary of Labor may investigate the employment practices of any Government contractor or sub-contractor to determine whether or not the contractual provisions specified in Section 202 of this order have been violated.*

The Lexington-Fayette Urban County Government practices Equal Opportunity in recruiting, hiring and promoting. It is the Government's intent to affirmatively provide employment opportunities for those individuals who have previously not been allowed to enter into the mainstream of society. Because of its importance to the local Government, this policy carries the full endorsement of the Mayor, Commissioners, Directors, and all supervisory personnel. In following this commitment to Equal Employment Opportunity and because the Government is the benefactor of the Federal funds, it is both against the Urban County Government policy and illegal for the Government to let contracts to companies which knowingly or unknowingly practice discrimination in their employment practices. Violation of the above mentioned ordinances may cause an Agreement to be canceled and the contractor may be declared ineligible for future consideration.

Please sign this statement in the appropriate space acknowledging that you have read and understand the provisions contained herein. Return this document as part of your application packet.

### Bidders

I/We agree to comply with the Civil Rights Laws listed above that govern employment rights of minorities, women, Vietnam veterans, handicapped, and aged persons.

\_\_\_\_\_  
Signature

\_\_\_\_\_  
Name of Business

The Entity (regardless of whether construction Contractor, non-construction Contractor or supplier) agrees to provide equal opportunity in employment for all qualified persons, to prohibit discrimination in employment because of race, color, creed, national origin, sex or age, and to promote equal employment through a positive, continuing program from itself and each of its sub-contracting agents. This program of equal employment opportunity shall apply to every aspect of its employment policies and practices.

The Kentucky Equal Employment Opportunity Act of 1978 (KRS 45.560-45.640) requires that any county, city, town, school district, water district, hospital district, or other political subdivision of the state shall include in directly or indirectly publicly funded contracts for supplies, materials, services, or equipment hereinafter entered into the following provisions:

During the performance of this contract, the contractor agrees as follows:

- (1) *The contractor will not discriminate against any employee or applicant for employment because of race, color, religion, sex, age or national origin;*
- (2) *The contractor will state in all solicitations or advertisements for employees placed by or on behalf of the contractors that all qualified applicants will receive consideration for employment without regard to race, color, religion, sex, age or national origin;*
- (3) *The contractor will post notices in conspicuous places, available to employees and applicants for employment, setting forth the provisions of the non-discrimination clauses required by this section; and*
- (4) *The contractor will send a notice to each labor union or representative of workers with which he has a collective bargaining agreement or other contract or understanding advising the labor union or workers' representative of the contractor's commitments under the nondiscrimination clauses.*

The Act further provides:

**KRS 45.610. Hiring minorities - Information required**

- (1) *For the length of the contract, each contractor shall hire minorities from other sources within the drawing area, should the union with which he has collective bargaining agreements be unwilling to supply sufficient minorities to satisfy the agreed upon goals and timetable.*
- (2) *Each contractor shall, for the length of the contract, furnish such information as required by KRS 45.560 to KRS 45.640 and by such rules, regulations and orders issued pursuant thereto and will permit access to all books and records pertaining to his employment practices and work sites by the contracting agency and the department for purposes of investigation to ascertain compliance with KRS 45.560 to 45.640 and such rules, regulations and orders issued pursuant thereto.*

**KRS 45.620. Action against contractor - Hiring of minority contractor or subcontractor**

- (1) *If any contractor is found by the department to have engaged in an unlawful practice under this chapter during the course of performing under a contract or subcontract covered under KRS 45.560 to 45.640, the department shall so certify to the contracting agency and such certification shall be binding upon the contracting agency unless it is reversed in the course of judicial review.*
- (2) *If the contractor is found to have committed an unlawful practice under KRS 45.560 to 45.640, the contracting agency may cancel or terminate the contract, conditioned upon a program for future compliance approved by the contracting agency and the department. The contracting agency may declare such a contractor ineligible to bid on further contracts with that agency until such time as the contractor complies in full with the requirements of KRS 45.560 to 45.640.*
- (3) *The equal employment provisions of KRS 45.560 to 45.640 may be met in part by a contractor by subcontracting to a minority contractor or subcontractor. For the provisions of KRS 45.560 to 45.640, a minority contractor or subcontractor shall mean a business that is owned and controlled by one or more persons disadvantaged by racial or ethnic circumstances.*

KRS 45.630 Termination of existing employee not required, when

*Any provision of KRS 45.560 to 45.640 notwithstanding, no contractor shall be required to terminate an existing employee upon proof that that employee was employed prior to the date of the contract.*

KRS 45.640 Minimum skills

*Nothing in KRS 45.560 to 45.640 shall require a contractor to hire anyone who fails to demonstrate the minimum skills required to perform a particular job.*

In the case of an Agreement exceeding \$250,000, the Contractor will be required within seven (7) days following the Bid Opening to furnish evidence that its work-force in Kentucky is representative of the available work-force in the area from which it draws employees, or to supply an Affirmative Action plan which will achieve such representation during the life of the Contract.

1.10 MWDBE SUBCONTRACTOR PARTICIPATION FORM



OMB Control No: 2090-0030  
 Approved: 8/13/2013  
 Approval Expires: 8/31/2015

**Disadvantaged Business Enterprise (DBE) Program  
 DBE Subcontractor Participation Form**

An EPA Financial Assistance Agreement Recipient must require its prime contractors to provide this form to its DBE subcontractors. This form gives a DBE<sup>1</sup> subcontractor<sup>2</sup> the opportunity to describe work received and/or report any concerns regarding the EPA-funded project (e.g., in areas such as termination by prime contractor, late payments, etc.). The DBE subcontractor can, as an option, complete and submit this form to the EPA DBE Coordinator at any time during the project period of performance.

Subcontractor Name		Project Name	
Bid/ Proposal No.	Assistance Agreement ID No. (if known)	Point of Contact	
Address			
Telephone No.		Email Address	
Prime Contractor Name		Issuing/Funding Entity:	

Contract Item Number	Description of Work Received from the Prime Contractor Involving Construction, Services, Equipment or Supplies	Amount Received by Prime Contractor

<sup>1</sup> A DBE is a Disadvantaged, Minority, or Woman Business Enterprise that has been certified by an entity from which EPA accepts certifications as described in 40 CFR 33.204-33.205 or certified by EPA. EPA accepts certifications from entities that meet or exceed EPA certification standards as described in 40 CFR 33.202.

<sup>2</sup> Subcontractor is defined as a company, firm, joint venture, or individual who enters into an agreement with a contractor to provide services pursuant to an EPA award of financial assistance.

**EPA FORM 6100-2 (DBE Subcontractor Participation Form)**





1.11 MWDBE SUBCONTRACTOR PERFORMANCE FORM



OMB Control No: 2090-0030  
 Approved: 8/13/2013  
 Approval Expires: 8/31/2015

**Disadvantaged Business Enterprise (DBE) Program  
 DBE Subcontractor Performance Form**

This form is intended to capture the DBE<sup>1</sup> subcontractor's<sup>2</sup> description of work to be performed and the price of the work submitted to the prime contractor. An EPA Financial Assistance Agreement Recipient must require its prime contractor to have its DBE subcontractors complete this form and include all completed forms in the prime contractors bid or proposal package.

Subcontractor Name		Project Name	
Bid/ Proposal No.	Assistance Agreement ID No. (if known)	Point of Contact	
Address			
Telephone No.		Email Address	
Prime Contractor Name		Issuing/Funding Entity:	

Contract Item Number	Description of Work Submitted to the Prime Contractor Involving Construction, Services, Equipment or Supplies	Price of Work Submitted to the Prime Contractor
DBE Certified By: ___ DOT ___ SBA ___ Other: _____		Meets/ exceeds EPA certification standards? ___ YES ___ NO ___ Unknown

<sup>1</sup> A DBE is a Disadvantaged, Minority, or Woman Business Enterprise that has been certified by an entity from which EPA accepts certifications as described in 40 CFR 33.204-33.205 or certified by EPA. EPA accepts certifications from entities that meet or exceed EPA certification standards as described in 40 CFR 33.202.

<sup>2</sup> Subcontractor is defined as a company, firm, joint venture, or individual who enters into an agreement with a contractor to provide services pursuant to an EPA award of financial assistance.

**EPA FORM 6100-3 (DBE Subcontractor Performance Form)**

**Disadvantaged Business Enterprise (DBE) Program  
DBE Subcontractor Performance Form**

I certify under penalty of perjury that the forgoing statements are true and correct. Signing this form does not signify a commitment to utilize the subcontractors above. I am aware of that in the event of a replacement of a subcontractor, I will adhere to the replacement requirements set forth in 40 CFR Part 33 Section 33.302 (c).

<b>Prime Contractor Signature</b>	<b>Print Name</b>
<b>Title</b>	<b>Date</b>

<b>Subcontractor Signature</b>	<b>Print Name</b>
<b>Title</b>	<b>Date</b>

The public reporting and recordkeeping burden for this collection of information is estimated to average three (3) hours per response. Send comments on the Agency's need for this information, the accuracy of the provided burden estimates, and any suggested methods for minimizing respondent burden, including through the use of automated collection techniques to the Director, Collection Strategies Division, U.S. Environmental Protection Agency (2822T), 1200 Pennsylvania Ave., NW, Washington, D.C. 20460. Include the OMB control number in any correspondence. Do not send the completed form to this address.

**EPA FORM 6100-3 (DBE Subcontractor Performance Form)**

1.12 MWDBE SUBCONTRACTOR UTILIZATION FORM



OMB Control No: 2090-0030  
 Approved: 8/13/2013  
 Approval Expires: 8/31/2015

**Disadvantaged Business Enterprise (DBE) Program  
 DBE Subcontractor Utilization Form**

This form is intended to capture the prime contractor's actual and/or anticipated use of identified certified DBE<sup>1</sup> subcontractors<sup>2</sup> and the estimated dollar amount of each subcontract. An EPA Financial Assistance Agreement Recipient must require its prime contractors to complete this form and include it in the bid or proposal package. Prime contractors should also maintain a copy of this form on file.

Prime Contractor Name		Project Name	
Bid/ Proposal No.	Assistance Agreement ID No. (if known)	Point of Contact	
Address			
Telephone No.		Email Address	
Issuing/Funding Entity:			

I have identified potential DBE certified subcontractors	<input type="checkbox"/> YES	<input type="checkbox"/> NO	
If yes, please complete the table below. If no, please explain:			
Subcontractor Name/ Company Name	Company Address/ Phone/ Email	Est. Dollar Amt	Currently DBE Certified?

Continue on back if needed

<sup>1</sup> A DBE is a Disadvantaged, Minority, or Woman Business Enterprise that has been certified by an entity from which EPA accepts certifications as described in 40 CFR 33.204-33.205 or certified by EPA. EPA accepts certifications from entities that meet or exceed EPA certification standards as described in 40 CFR 33.202.

<sup>2</sup> Subcontractor is defined as a company, firm, joint venture, or individual who enters into an agreement with a contractor to provide services pursuant to an EPA award of financial assistance.

**EPA FORM 6100-4 (DBE Subcontractor Utilization Form)**

**Disadvantaged Business Enterprise (DBE) Program  
DBE Subcontractor Utilization Form**

I certify under penalty of perjury that the forgoing statements are true and correct. Signing this form does not signify a commitment to utilize the subcontractors above. I am aware of that in the event of a replacement of a subcontractor, I will adhere to the replacement requirements set forth in 40 CFR Part 33 Section 33.302 (c).

<b>Prime Contractor Signature</b>	<b>Print Name</b>
<b>Title</b>	<b>Date</b>

The public reporting and recordkeeping burden for this collection of information is estimated to average three (3) hours per response. Send comments on the Agency's need for this information, the accuracy of the provided burden estimates, and any suggested methods for minimizing respondent burden, including through the use of automated collection techniques to the Director, Collection Strategies Division, U.S. Environmental Protection Agency (2822T), 1200 Pennsylvania Ave., NW, Washington, D.C. 20460. Include the OMB control number in any correspondence. Do not send the completed form to this address.

**EPA FORM 6100-4 (DBE Subcontractor Utilization Form)**

**1.13 MWDBE PARTICIPATION POLICY**

**PROJECT NAME:** \_\_\_\_\_

Lexington-Fayette Urban County Government

**LFUCG BID NO.** \_\_\_\_\_

**BID DATE:** \_\_\_\_\_

**A. Name, address and telephone number of contact person on all MWDBE matters:**

Prime Contractor's Name \_\_\_\_\_  
Contact Person: \_\_\_\_\_  
Address: \_\_\_\_\_  
Phone: \_\_\_\_\_ Cell: \_\_\_\_\_  
Email: \_\_\_\_\_  
Total Contract Amount: \_\_\_\_\_

**B. Total dollar amount/percent of contract of DBE participation:** \_\_\_\_\_

**C. Total dollar amount/percent of contract of MBE participation:** \_\_\_\_\_

**D. Total dollar amount/percent of contract of WBE participation:** \_\_\_\_\_

**E. Are certifications\* for each MWDBE subcontractor enclosed; if no, please explain:**

Yes  No \_\_\_\_\_

**F. Are MWDBE subcontracts or letters of intent signed by both parties enclosed; if no, please explain:**  Yes  No \_\_\_\_\_

**G. List of DBE Subcontractors:**

Name \_\_\_\_\_  
Contact Person: \_\_\_\_\_  
Address: \_\_\_\_\_  
Phone: \_\_\_\_\_ Cell: \_\_\_\_\_  
Email: \_\_\_\_\_  
Type of Contract: \_\_\_\_\_  
Work to be Done: \_\_\_\_\_  
Amount: \_\_\_\_\_

**H. List of MBE Subcontractors:**

Name \_\_\_\_\_  
Contact Person: \_\_\_\_\_  
Address: \_\_\_\_\_  
Phone: \_\_\_\_\_ Cell: \_\_\_\_\_  
Email: \_\_\_\_\_  
Type of Contract: \_\_\_\_\_  
Work to be Done: \_\_\_\_\_  
Amount: \_\_\_\_\_

**I. List of WBE Subcontractors:**

Name \_\_\_\_\_  
 Contact Person: \_\_\_\_\_  
 Address: \_\_\_\_\_  
 Phone: \_\_\_\_\_ Cell: \_\_\_\_\_  
 Email: \_\_\_\_\_  
 Type of Contract: \_\_\_\_\_  
 Work to be Done: \_\_\_\_\_  
 Amount: \_\_\_\_\_

**Attach additional sheets, if necessary.**

\*Self-certification: Self-certification of MWDBE firms will NOT be accepted as a valid form of certification of MWDBE status.

**J. Information and documentation concerning efforts taken to comply with EPA's "six good faith efforts"**

1. Ensure MWDBE construction firms or material suppliers are made aware of contracting opportunities to the fullest extent practicable through outreach and recruitment activities; including placing MWDBEs on solicitation lists and soliciting them whenever they are potential sources. A good source for a list of MWDBEs is the Kentucky Transportation's website: <http://transportation.ky.gov/Civil-Rights-and-Small-Business-Development/Pages/Certified-DBE-Directory.aspx>.

The prime contractor certifies that a bidders list (see example sheet below) of qualified vendors, including MWDBEs, was developed for current and future solicitations and that the list will be maintained. *Submit a copy of the list as documentation.*

2. Make information on forthcoming opportunities available to MWDBEs and arrange time frames for contracts and establish delivery schedules, where the requirements permit, in a way that encourages and facilitates participation by MWDBEs in the competitive process; including, whenever possible, posting solicitation for bids or proposals for a sufficient amount of time as to receive a competitive bid or proposal pool.

The prime contractor certifies that every opportunity was provided to a number of MWDBEs to encourage their participation in the competitive process and that an adequate amount of time was provided for response.

- a. List each MWDBE construction firm or material supplier to which a solicitation was attempted. *Submit copies of letters, emails, faxes, telecommunication logs, certified mail receipts, returned envelopes, certified mail return receipts, etc. as documentation.*

Company Name and Phone Number: \_\_\_\_\_

Area of Work Expertise: \_\_\_\_\_

Date of any Follow-Ups and Person Spoke to: \_\_\_\_\_

- b. Advertisements, if applicable: List each publication in which an announcement or notification was placed. *Submit a tear sheet of each announcement from each publication as documentation.*

Name of Publication: \_\_\_\_\_

Date(s) of Advertisement: \_\_\_\_\_

Specific Subcontract Areas Announced: \_\_\_\_\_

- c. Other, if applicable: List each notification method in which an announcement or outreach was used; list serve, public meeting, etc. *Submit applicable information to document effort.*

Method of Notification: \_\_\_\_\_

Date(s) of Notification: \_\_\_\_\_

3. Consider in the contracting process whether firms competing for large contracts could subcontract with MWDBEs; including dividing total requirements, when economically feasible, into smaller tasks or quantities to permit maximum participation by MWDBEs in the competitive process.

The prime contractor certifies that the project was broken into its basic elements (i.e. dirt hauling, landscaping, painting, pipe installation, material supplies, etc.) and that a determination was made whether it's economically feasible to bid the elements separately and that the analysis of this effort was documented with a short memo to the project file.

4. Establishing delivery schedules, where the requirement permits, which encourage participation by small and minority business, and women's business enterprises.

The prime contractor certifies that they established delivery schedules which would allow MWDBEs to participate in the projects.

5. Use the services and assistance of the Small Business Administration (SBA) and the Minority Business Development Agency (MBDA) of the U.S. Department of Commerce. The easiest way to utilize the services of SBA and MBDA is to visit their websites: [www.sba.gov](http://www.sba.gov) and [www.mbda.gov](http://www.mbda.gov) and use the electronic tools available there or you may send the nearest SBA and MBDA office a certified letter that generally describes the solicitation, the dates it will be open, the types of vendors you are seeking and applicable SIC or NAIC codes if known. You may also use the services and assistance of the Kentucky Procurement Assistance Program (KPAP). The easiest way to utilize the services of KPAP is to send an email: [ced.kpap@ky.gov](mailto:ced.kpap@ky.gov) and provide information on forthcoming opportunities available to MWDBEs.

The prime contractor certifies that the assistance of the SBA, MBDA, and/or KPAP was utilized. *Submit pages printed off the SBA and MBDA websites which evidence efforts to register a solicitation on those sites or submit copies of the letter send and certified mail receipt as documentation; submit copies of emails with KPAP as documentation.*

6. If a subcontractor awards any subcontracts, require the subcontractor to take the steps in numbers 1 and 5 above.

The prime contractor certifies that subcontractors used for this project will be required to follow the steps of the "six good faith efforts" as listed above.

**Signature and Date:**

To the best of my knowledge and belief, all "six good faith efforts" have been met and the information contained in this document is true and correct; the document has been duly authorized by the legal representative.

\_\_\_\_\_  
Signature

\_\_\_\_\_  
Print Name and Title

\_\_\_\_\_  
Date



**1.14 EQUAL EMPLOYMENT OPPORTUNITY AFFIRMATIVE ACTION POLICY**

It is the policy of \_\_\_\_\_  
(Name of Bidder)

to assure that all applicants for employment and all employees are treated on a fair and equitable basis without regard to their race, religion, sex, color, handicap, natural origin or age.

Such action shall include employment, promotion, demotion, recruitment or recruitment advertising, layoff or termination, rates of pay and other forms of compensation, and selection for training, whether apprenticeship and/or on-the-job-training.

Furthermore, this company agrees to make special recruitment efforts to hire the protected class whenever feasible. This company also agrees to adhere to all applicable federal, state, and local laws relating to Equal Employment Opportunity for all individuals.

1.15 WORKFORCE ANALYSIS FORM

Name of Organization: \_\_\_\_\_

Categories	Total		White (not Hispanic or Latino)		Hispanic or Latino		Black or African-American (not Hispanic or Latino)		Native Hawaiian and other Pacific Islander (not Hispanic or Latino)		Asian (not Hispanic or Latino)		American Indian or Alaskan Native (not Hispanic or Latino)		Two or more races (not Hispanic or Latino)		Total		
	M	F	M	F	M	F	M	F	M	F	M	F	M	F	M	F	M	F	
Administrators																			
Professionals																			
Superintendents																			
Supervisors																			
Foremen																			
Technicians																			
Protective Service																			
Para-Professionals																			
Office/Clerical																			
Skilled Craft																			
Service/Maintenance																			
Total																			

Prepared By: \_\_\_\_\_

Date / / \_\_\_\_\_

1.16 EVIDENCE OF INSURABILITY

LEXINGTON-FAYETTE UBAN COUNTY GOVERNMENT CONTRUCTION PROJECT  
 (Use separate form for each Agency or Brokerage agreeing to provide coverage)

Names Insured: \_\_\_\_\_  
 Address: \_\_\_\_\_  
 Project to be insured: \_\_\_\_\_

In lieu of obtaining certificates of insurance at this time, the undersigned agrees to provide the above Named Insured with the minimum coverage listed below. These are outlined in the Insurance and Risk Management of Section 00600 - Bonds and Certifications, including all requirements, and conditions:

Article Items	Coverage	Minimum Limits and Policy Requirements	Limits Provided to Insured	Name of Insurer	A.M. Best's	
					Code	Rating
1.05.D.1	CGL	\$1,000,000/per occ., \$2,000,000/aggregate or \$2,000,000 combined single limit Requirements (a) through (e)				
1.05.D.1	Auto	Combined single \$1,000,000/per occ. aggregate Requirements (a) through (c)				
1.05.D.1	WC	\$ _____ Statutory				
1.05.D.1	Employer's Liability	\$500,000				

Section 00600 includes required provisions, statements regarding insurance requirements, and the undersigned agrees to abide by all provisions for the coverage's checked above unless stated otherwise when submitting

Agency or Brokerage \_\_\_\_\_ Name of Authorized Representative \_\_\_\_\_  
 Street Address \_\_\_\_\_ Title \_\_\_\_\_  
 City \_\_\_\_\_ Authorized Signature \_\_\_\_\_  
 Telephone Number \_\_\_\_\_ Date \_\_\_\_\_

NOTE: Authorized signatures may be the agent's if agent has placed insurance through an agency agreement with the insurer. If insurance is brokered, authorized signature must be that of authorized representative of insurer.

**IMPORTANT: CONTRACT MAY NOT BE AWARDED IF A COMPLETED AND SIGNED COPY OF THIS FORM FOR ALL COVERAGES LISTED ABOVE IS NOT PROVIDED.**

**1.17 DEBARRED FIRMS**

**PROJECT NAME:**

**LFUCG BID NO.:**

**LEXINGTON-FAYETTE URBAN COUNTY GOVERNMENT  
LEXINGTON, KY**

All prime Contractors shall certify that Subcontractors have not and will not be awarded to any firms that has been debarred for noncompliance with the Federal Labor Standards, Title VI of the Civil Rights Act of 1964 As Amended, Executive Order 11246 As Amended or any other Federal Law.

All Bidders shall complete the Debarment Certification in duplicate and submit both copies to the Owner with the Bid Form. The Owner (grantee) shall transmit one copy to the Lexington-Fayette Urban County Government, Division of Community Development within fourteen (14) days after Bid opening.

The undersigned hereby certifies that the firm of \_\_\_\_\_ has not and will not award a subcontract, in connection with any Agreement award to it as the result of this bid, to any firm that has been debarred for noncompliance with the Federal Labor Standards, Title VI of the Civil Rights Act of 1964, Executive Order 11246 As Amended or any Federal Law.

\_\_\_\_\_  
Name of Firm Submitting Bid

\_\_\_\_\_  
Signature of Authorized Official

\_\_\_\_\_  
Title

\_\_\_\_\_  
Date

**1.18 DEBARMENT CERTIFICATION**

All Contractors/Subcontractors shall complete this certification.

The Contractor/Subcontractor certifies in accordance with Executive Order 12549 (Debarment and Suspension 2/18/86) that to the best of its knowledge and belief, that it and its principals:

- 1) Are not presently debarred, suspended, proposed for debarment, declared negligible, or voluntarily excluded from covered transactions or contract by any Federal department or agency for noncompliance with the Federal Labor Standards, Title VI of the Civil Rights Act of 1964 As Amended, Executive Order 11246 As Amended or any other Federal Law.
  - a) Have not within a three year period preceding this Bid been convicted of or had a civil judgment rendered against them for commission of fraud or a criminal offense in connection with obtaining, attempting to obtain, or performing a public (Federal, State or local) transaction or contract under a public transaction; violation of Federal or State antitrust statutes or commission of embezzlement, theft, forgery, bribery, falsification or destruction of records, making false statements or receiving stolen property;
  - b) Are not presently indicted for or otherwise criminally or civilly charged by a government entity (Federal, State or local) with commission of any of the offenses enumerated in paragraph (1)(a) of this certification; and
  - c. Have not within a three (3) year period preceding this Bid has one or more public (Federal, State or local) transactions or contracts terminated for cause or default.
- 2) Where the Contractor is unable to certify to any of the statements in this certification, such prospective contractors shall attach an explanation to this certification form.

Firm Name: \_\_\_\_\_

Project: \_\_\_\_\_

Printed Name: \_\_\_\_\_

Title of Authorized Representative: \_\_\_\_\_

Signature: \_\_\_\_\_

Date: \_\_\_\_\_

**1.19 CERTIFICATION REGARDING LOBBYING**

**Certification for Contracts, Grants, Loans, and Cooperative Agreements**

The undersigned certifies, to the best of his or her knowledge and belief, that:

- (1) No Federal appropriated funds have been paid or will be paid, by or on behalf of the undersigned, to any person for influencing or attempting to influence an officer or employee of an agency, a Member of Congress, an officer or employee of Congress, or an employee of a Member of Congress in connection with the awarding of any Federal contract, the making of any Federal grant, the making of any Federal loan, the entering into of any cooperative agreement, and the extension, continuation, renewal, amendment, or modification of any Federal contract, grant, loan, or cooperative agreement.
- (2) If any funds other than Federal appropriated funds have been paid or will be paid to any person for influencing or attempting to influence an officer or employee of any agency, a Member of Congress, an officer or employee of Congress, or an employee of a Member of Congress in connection with this Federal contract, grant, loan, or cooperative agreement, the undersigned shall complete and submit Standard Form-LLL, "Disclosure Form to Report Lobbying," in accordance with its instructions.
- (3) The undersigned shall require that the language of this certification be included in the award documents for all sub-awards at all tiers (including subcontracts, sub-grants, and contracts under grants, loans, and cooperative agreements) and that all sub-recipients shall certify and disclose accordingly.

This certification is a material representation of fact upon which reliance was placed when this transaction was made or entered into. Submission of this certification is a prerequisite for making or entering into this transaction imposed by Section 1352, Title 31, U.S. Code. Any person who fails to file the required certification shall be subject to a civil penalty for not less than \$10,000 and not more than \$100,000 for each such failure.

\_\_\_\_\_  
Typed Name & Title of Authorized Representative

\_\_\_\_\_  
Signature of Authorized Representative

\_\_\_\_\_  
Date

\_\_\_\_\_ I am unable to certify to the above statements. My explanation is attached.

1.20 BID BOND

BID BOND

Bond Number: \_\_\_\_\_

KNOW ALL MEN BY THESE PRESENTS, that we \_\_\_\_\_

as principal (the "Principal") and \_\_\_\_\_

hereinto called Surety, are held and firmly bound unto

LEXINGTON-FAYETTE URBAN COUNTY GOVERNMENT  
200 East Main Street, Third Floor  
Lexington, Kentucky 40507

as obligee (the "Obligee"), in the penal sum of \_\_\_\_\_ dollars for the payment of which sum well and truly to be made, the said Principal and the said Surety, bind ourselves, our heirs, executors, administrators, successors and assigns, jointly and severally, firmly by these presents.

WHEREAS, the Principal has submitted a bid for \_\_\_\_\_

NOW, THEREFORE, if the Obligee shall accept the bid of the Principal within the period specified therein, or, if no period be specified, within ninety (90) days after opening, and the Principal shall enter into a contract with the Obligee in accordance with the terms of such bid, and give such bond or bonds as may be specified in the bidding or contract documents, or in the event of the failure of the Principal to enter into such contract and give such bond or bonds, if the Principal shall pay to the Obligee the difference in money not to exceed the penal sum hereof between the amount specified in said bid and such larger amount for which the Obligee may in good faith contract with another party to perform the work covered by said bid, then this obligation shall be null and void; otherwise to remain in full force and effect. In no event shall the liability hereunder exceed the penal sum thereof.

PROVIDED AND SUBJECT TO THE CONDITION PRECEDENT, that any claim by Obligee under this bond must be submitted in writing by registered mail, to the attention of the Surety Law Department at the address above, within 120 days of the date of this bond. Any suit under this bond must be instituted before the expiration of one (1) year from the date of this bond. If the provisions of this paragraph are void or prohibited by law, the minimum period of limitation available to sureties as a defense in the jurisdiction of the suit shall apply.

DATED as of this \_\_\_\_\_ day of \_\_\_\_\_, 20\_\_\_\_\_.

WITNESS / ATTEST:

\_\_\_\_\_  
Principal (Secretary)

\_\_\_\_\_  
Principal

By: \_\_\_\_\_ (seal)  
Name:  
Title:

\_\_\_\_\_  
Surety (Secretary)

\_\_\_\_\_  
Surety

By: \_\_\_\_\_ (seal)  
Name:  
Title:

# POWER OF ATTORNEY

(Attach to Bid Bond)

END OF SECTION



EA3 Pump Station (Contract No. 1) Equipment Manufacturer (circle one) – Bid Basis	
Solids Handling Submersible Pumps	ABS Flygt KSB
Mechanical Bar Screens	Headworks Huber Technology Duperon
Screenings Compactors	Headworks Huber Technology Duperon
Screening Conveyors	Headworks Huber Technology Duperon
Sump Pumps	Myers Flygt Hydromatic Zoeller
Odor Control Absorber	ECS Environmental Solutions/Calgon Daniel Company Pure Air Filtration
Odor Control Chemical Feed System	Evoqua
Check Valves	Apco Golden Anderson Val-matic
Modulating Plug Valve	Dezurik Golden Anderson Henry Pratt
Slide/Sluice Gates	Aquanox Waterman Golden Harvest
Electric Actuators	Limatorque Auma EIM
Generator	Generac Caterpillar Cummins/ONAN MTU/Detroit Diesel Kohler
Level Transmitters	Endress+Hauser Foxboro Siemens Yokogawa
VFDs	Square D Eaton Allen Bradley
SCADA PLC's	Allen Bradley Compactlogix
Motor Control Centers	Square D Cutler Hammer Allen Bradley



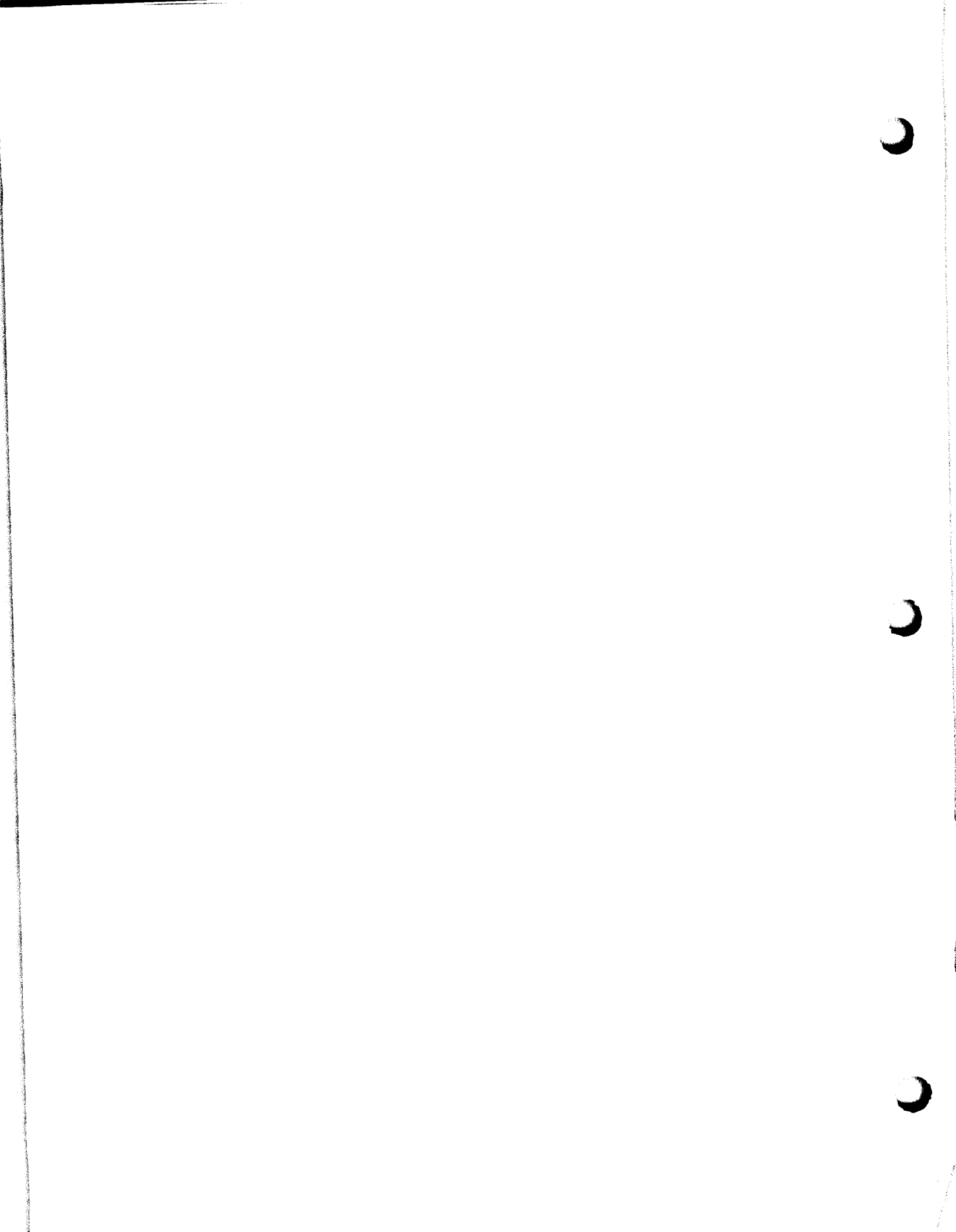

**BMP KEYNOTES:**

- ① INSTALL SILT FENCE PER CHAPTER 11, FIGURES 11-21 AND 11-22 OF THE LFUGG STORMWATER MANUAL.
- ② INSTALL ROCK CONSTRUCTION EXIT PER CHAPTER 11, FIGURES 11-3 AND 11-4 OF THE LFUGG STORMWATER MANUAL.
- ③ INSTALL ROCK CHECK DAMS PER CHAPTER 11, FIGURES 11-16 OF THE LFUGG STORMWATER MANUAL.

**BMP NOTES**

1. CONTRACTOR IS REQUIRED TO CLEAN UP ALL ADJACENT ROADWAYS EACH DAY OF DEBRIS, DIRT, MUD, ETC. NO MUD IS ALLOWED TO BE TRACKED ONTO THE PAVED AREAS.

**CAUTION NOTICE TO CONTRACTOR:**

IF PROPERLY IMPLEMENTED, THIS PLAN WILL PROVIDE AN EFFECTIVE MEANS FOR CONTROLLING EROSION. HOWEVER, IT IS ACKNOWLEDGED THAT NO ONE PLAN CAN BE PREPARED THAT WILL DEPICT ALL POSSIBLE CONTROL MEASURES NECESSARY FOR VARIOUS STAGES OF CONSTRUCTION. THE CONTRACTOR SHALL INCLUDE IN THE BASE BID ADEQUATE FUNDS TO PROVIDE ALL EROSION CONTROL MEASURES NECESSARY TO COMPLY WITH CODES FOR THE DURATION OF THE CONSTRUCTION PROJECT.

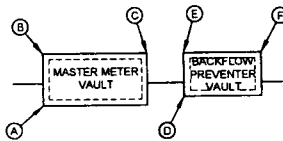

STRUCTURE COORDINATES			
POINT	NORTHING	EASTING	STRUCTURE
A	219341.90	1574159.40	METER VAULT
B	219344.52	1574153.45	METER VAULT
C	219356.41	1574158.68	METER VAULT
D	219358.32	1574165.52	BACKFLOW VAULT
E	219360.53	1574160.49	BACKFLOW VAULT
F	219369.23	1574164.31	BACKFLOW VAULT

**VAULT LOCATION COORDINATES**

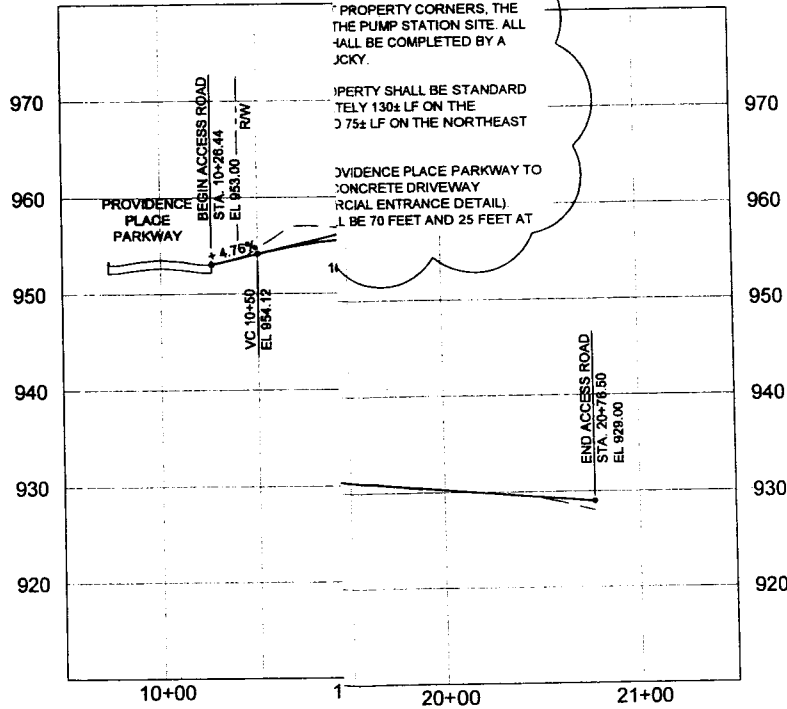

**PROFILE**

SCALE: 1"=50' HORZ.  
1"=5' VERT.

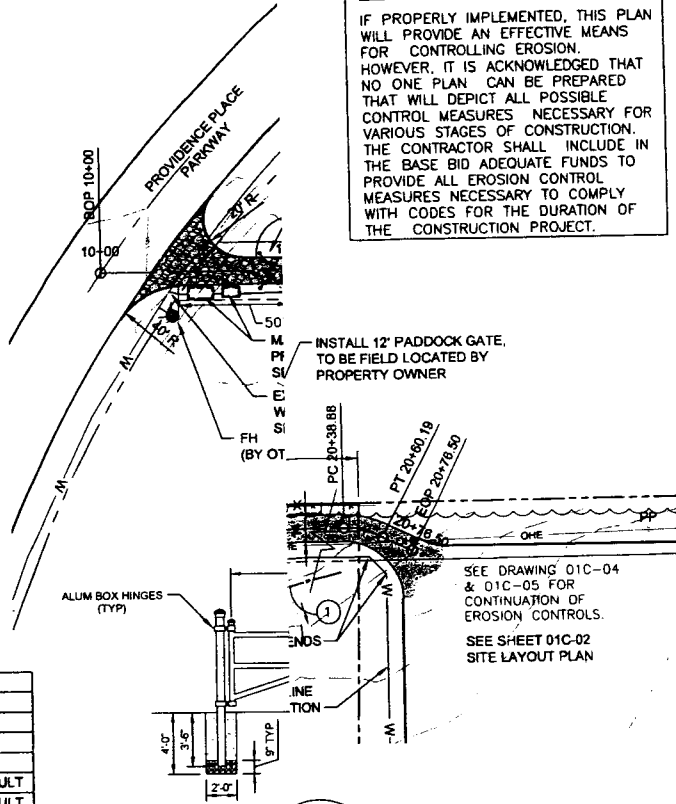

**DOUBLE T**

ATION OF PERMANENT EASEMENT AND ENTRANCE PROVIDENCE PLACE PARKWAY. ALSO PROPERTY CORNERS, THE THE PUMP STATION SITE. ALL SHALL BE COMPLETED BY A JACKY.

PROPERTY SHALL BE STANDARD WIDELY 130± LF ON THE 75± LF ON THE NORTHEAST

PROVIDENCE PLACE PARKWAY TO CONCRETE DRIVEWAY (SEE DETAIL). SHALL BE 70 FEET AND 25 FEET AT

NOTE: ALL WATER LINE FITTINGS SHALL BE RESTRAINED JOINTS. ALL WATER LINE PIPE JOINTS SHALL BE RESTRAINED 30 FEET EITHER SIDE OF A FITTING.



: MAIN	
1	9/8/17
DATE	

**ACCESS ROAD PLAN AND PROFILE**

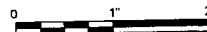

FILENAME | 01C-09.dwg  
SCALE | AS NOTED

SHEET  
**01C-09**







**PLUMBING GENERAL NOTES**

- THE EQUIPMENT ROUGH-IN ITEMS AND THEIR DIMENSIONED LOCATIONS FOR ALL CONNECTIONS ARE ACCURATE TO THE BEST OF OUR KNOWLEDGE. IN SOME INSTANCES THE OWNER OR SUPPLIER MAY MAKE SUBSTITUTIONS OR THE EQUIPMENT ITEMS MAY VARY FROM WHAT IS SHOWN. THEREFORE, THESE ITEMS AND DIMENSIONS SHALL BE VERIFIED WITH THE EQUIPMENT SUPPLIER, OWNER AND/OR EQUIPMENT ROUGH-IN DRAWINGS. THE ARCHITECT/ENGINEER SHALL BE IMMEDIATELY NOTIFIED, PRIOR TO CONSTRUCTION, OF ANY DEVIATIONS FROM WHAT IS SHOWN OR IMPLIED ON THESE DRAWINGS. FAILURE OF THE APPROPRIATE CONTRACTOR TO VERIFY ROUGH-INS OR THEIR LOCATIONS SHALL PLACE THE RESPONSIBILITY FOR ANY SUBSEQUENT RELOCATION AND/OR ADDITIONAL ROUGH-INS DIRECTLY UPON THE CONTRACTOR.
- CONTRACTOR SHALL SUPPLY TO THE ARCHITECT SIX COPIES OF SHOP DRAWINGS FOR APPROVAL SO THE QUALITY OF INTENDED MATERIALS OR EQUIPMENT CAN BE REVIEWED BEFORE INSTALLATION. THERE WILL BE NO DRAW UNLIT SHOP DRAWINGS HAVE BEEN SUBMITTED AND REVIEWED BY ARCHITECT/ENGINEER.
- DO NOT SCALE THIS DRAWING. REFER TO ARCHITECTURAL FLOOR PLAN FOR BUILDING DIMENSIONS.
- THE SUBMISSION OF A PROPOSAL WILL BE CONSTRUED AS EVIDENCE THAT THE CONTRACTOR HAS FAMILIARIZED HIMSELF WITH THE PLANS AND BUILDING SITE. CLAIMS MADE SUBSEQUENT TO THE PROPOSAL FOR MATERIALS AND LABOR BECAUSE OF DIFFICULTIES ENCOUNTERED WILL NOT BE RECOGNIZED, IF THEY COULD HAVE BEEN FORESEEN HAD PROPER EXAMINATION BEEN MADE.
- ALL ROOF PENETRATIONS FOR PLUMBING PIPING SHALL BE MADE IN ACCORDANCE WITH ROOF SYSTEM MANUFACTURER'S GUIDELINES. COORDINATE WITH ARCHITECTURAL DETAILS AND/OR LANDLORD FOR ROOF SYSTEM USED.
- FURNISH AND INSTALL SHUTOFF OR BALL VALVE AND DIELECTRIC UNION ON ALL EQUIPMENT HOT AND COLD WATER LINES. PLUMBING CONTRACTOR SHALL MAKE ALL FINAL CONNECTIONS TO EQUIPMENT. COORDINATE WITH EQUIPMENT SUPPLIER FOR EXACT REQUIREMENTS.
- FURNISH & INSTALL 1/2" (MIN) FIBERGLASS INSULATION WITH ALL-SERVICE JACKET ON ALL HOT, COLD & RECIRCULATING WATER LINES IN ENTIRE BLDG.
- WATER PIPE AND FITTINGS SHALL BE COPPER OR BRASS PER CODE. ABOVE GROUND SHALL BE TYPE L RIGID COPPER. BELOW GROUND SHALL BE TYPE K SOFT COPPER WITH NO JOINTS PERMITTED BELOW GROUND. ALL JOINTS SHALL BE MADE WITH 95-5 SOLDER OR EQUAL.
- MATERIALS, EQUIPMENT, ASSEMBLIES AND SYSTEMS SHALL MEET ALL PERTINENT REQUIREMENTS OF NATIONALLY RECOGNIZED TESTING ORGANIZATION SUCH AS THE UL, ASTM, ASSE, ANMA, AGA AND NFPA AS WELL AS THE MOST CURRENT VERSION OF THE STATE CODE AND LOCAL AMENDMENTS.
- ALL VENT PIPE TO BE COMPATIBLE WITH STRUCTURE, MECHANICAL EQUIPMENT AND DUCTWORK, ELECTRICAL EQUIPMENT AND LIGHTING.
- THE CONTRACTOR SHALL COOPERATE FULLY AMONG THE TRADES.
- FURNISH AND INSTALL CONDENSATE LINES FROM ANY MECHANICAL EQUIPMENT AS REQUIRED. ANY CONDENSATE LINE RUN ABOVE THE CEILING OR IN A LOCATION WHERE THE PIPE'S SWEATING COULD CAUSE DAMAGE, SHALL BE INSULATED. SEE NOTE 7 FOR INSULATION REQUIREMENTS. RUN FULL SIZE TO DRAIN OR AS INDICATED ON PLANS. TURN DOWN WITH REQUIRED AIR GAP.
- PLUMBING CONTRACTOR SHALL VERIFY WITH THE LOCAL HEALTH DEPARTMENT AND/OR WATER COMPANY AS TO THE METER AND VALVING ARRANGEMENTS OF THE DOMESTIC WATER SERVICE LINE WHICH ENTERS THE BUILDING. SHOULD A BACKFLOW PREVENTER ASSEMBLY AND/OR PRESSURE REDUCING VALVE ASSEMBLY BE REQUIRED, THE PLUMBER SHALL FURNISH AND INSTALL SAME PER LOCAL AND STATE REQUIREMENTS. THE BACKFLOW ASSEMBLY SHALL BE A "WATTS" SERIES #909, OR APPROVED EQUAL MEETING ASSE STANDARDS 1013, 1015 AND 1020. IF WATER PRESSURE IS 80 PSI OR ABOVE, THE PRESSURE REDUCING VALVE ASSEMBLY SHALL BE A "WATTS" SERIES #J5 SET AT 50 LBS. DELIVERY PRESSURE UNLESS OTHERWISE NOTED.
- THE POTABLE WATER SUPPLY SHALL BE PROTECTED AGAINST BACKFLOW AND SIPHONAGE BOTH NATURAL AND INDUCED. ALL EQUIPMENT CONNECTED TO THE POTABLE WATER SYSTEM BEING CAPABLE OF POLLUTING OR CONTAMINATING THE POTABLE WATER DISTRIBUTION SYSTEM OR ANY PART THEREOF BY MEANS OF A REVERSAL OF FLOW, PRESSURE DROP, PRESSURE LOSS, INDUCED VACUUM OR BY INJECTION BECAUSE OF ANY PRIMARY OR AUXILIARY PUMPING SYSTEM CONNECTED THERETO MUST BE ISOLATED AND CONTAINED BY MEANS OF APPROVED BACKFLOW DEVICES, CHECK VALVES, AIR GAPS OR VACUUM BREAKERS. PLUMBING CONTRACTOR SHALL FURNISH AND INSTALL THESE DEVICES PER LOCAL CODE REQUIREMENTS.

**PLUMBING FIXTURE SCHEDULE**

W	HW	CW	WASTE	DESCRIPTION
TOILET CLOSET (RIFER FREE)	--	1/2"	4"	AMERICAN STANDARD "CHAMPION" PRESSURE ASSIST MODEL NO. 2372-1000 1.6 GAL. FLUSH, WHITE OPEN FRONT PLASTIC SEAT W/O COVER, PROVIDE CHROME PLATED BRASS SUPPLY AND STOP. TOP OF SEAT AT 18" A.F.F.
W/ATDRY OP-IN TYPE (RIFER FREE)	1/2"	1/2"	1 1/2"	KOHLER "PENNINGTON" No K-2196 : VITREOUS CHINA, DROP IN 20 1/2" X 17 1/2" WITH OVERFLOW AND SINGLE FAUCET HOLE. PROVIDE KOHLER "CORALAIS" No K-15182, SINGLE LEVER, CERAMIC DISC VALVES. POP UP DRAIN WITH 1 1/2" TAILPIECE.GRID DRAIN, P-TRAP, CHROME FITTINGS. PROVIDE TRAP WRAP FOR BARRIER FREE PROTECTION WHERE REQUIRED.
OR IN	--	--	3"	JAY R. SMITH, 2005-A, 6" SQUARE POLISHED BRONZE TOP. TRAP PRIMER CONN. IF REQ'D.
IN/ N EPTACLE	--	--	LINE SIZE	JAY R. SMITH 2646 ZURN OR WADE STRAIGHT SPIGOT ADAPTER WITH TOP AT 4" AFF OR AS REQUIRED.
SE BIBB (TERIOR)	--	1/2"	--	WOODFORD MODEL 24P-1/2 WITH TEE KEY. VACUUM BREAKER AND POLISHED CHROME FINISH. PROVIDE TWO KEYS TO OWNER FOR EACH UNIT.
I. HYDRANT (TERIOR)	--	3/4"	--	WOODFORD MODEL 65. AUTOMATIC DRAINING, FREEZELESS WITH VACUUM BREAKER, LOOSE KEY. PROVIDE TWO KEYS TO OWNER FOR EACH UNIT.
RGENCY ) WASH ) SHOWER	1-1/4"	1-1/4"	--	BRADLEY EYEWASH/SHOWER UNIT MODEL S19 310AC, 18" ROUND YELLOW IMPACT RESISTANT PLASTIC BOWL, STANDARD SPRAY HEAD ASSEMBLY, STAY OPEN BALL VALVE HAND OPERATED, DOME STRAINER AND DRAIN FITTING. 1" STAY OPEN SHOWER VALVE WITH PULL ROD AND TRIANGLE HANDLE
W/FLOW VENTER	--	1-1/2"	--	SEE P-1 FOR DETAIL.
TER VTER	1"	1"	--	A.O. SMITH, DEN-1200, 119 GALLON CAPACITY, 12 GPH RECOVERY AT 100 DEG F., 2 ELEMENTS, 3 KW EACH, 208V SINGLE PHASE WIRE ELEMENTS NON-SIMULTANEOUS, FACTORY INSTALLED ASME AND ANSI Z21.22 RATED TEMP. PRESSURE RELIEF VALVE AND AMTROL THERM-X-TROL MODEL ST-12 EXPANSION TANK, 4.5 GAL. TANK VOLUME, 3.2 GAL. ACCEPTANCE FACTOR.(SEE WATER HEATER DETAIL.)
SINK	1/2"	1/2"	3"	FIAT MOLDED STONE MOP SERVICE BASIN MSB2424. PROVIDE WITH SERVICE FAUCET 838-AA, HOSE AND HOSE BRACKET 832-AA, MOP HANGER 889-CC.
ING VALVE RGENCY SHOWER	1-1/4"	1-1/4"	--	SYMMONS, BRADLEY OR APPROVED EQUIVALENT, SET AT 85F.
USED				
ING VALVE TROOM LAVATORY	1/2"	1/2"	--	BRADLEY NAVIGATOR MODEL S59-4000BY, SUPPLIED WITH MOUNTING BRACKET, BY-PASS FOR COLD WATER SUPPLY TO FAUCET, INTEGRAL CHECK VALVES AND STRAINERS. P.C SHALL SET TEMPERATURE AT 110F

RES IN SCHEDULE MAY NOT BE USED.  
 LL EQUIPMENT POWER REQUIREMENTS WITH EC PRIOR TO PURCHASE.

**PLUMBING FIXTURE SCHEDULE NOTES:**

- CONTRACTOR SHALL FURNISH AND INSTALL CARRIER FOR EACH FIXTURE WHICH IS WALL HUNG, UNLESS OTHERWISE NOTED. PROVIDE APPROPRIATE CARRIER PER FIXTURE TYPE AND REQUIREMENTS.
- CONTRACTOR SHALL FURNISH AND INSTALL P.P.P. INC. TRAP PRIMERS, MODEL OREGON #1 TO SERVE ALL APPROPRIATE FLOOR DRAINS AND/OR OPEN RECEPTABLES AS REQUIRED.
- ACCEPTABLE ALTERNATE MANUFACTURERS FOR ITEMS INCLUDING BUT NOT LIMITED TO WATER CLOSETS: AMERICAN STANDARD, KOHLER, ELGER, CRANE, MANSFIELD FLOOR DRAINS AND CLEANOUTS: WADE, J.R. SMITH, ZURN, PLASTIC COODITIES, WATER HEATERS: STATE, LOCKINVAR, RHEEM HOSE BIBBS/WALL HYDRANTS: WOODFORD, ZURN, CHICAGO FAUCET, T&S BRASS.

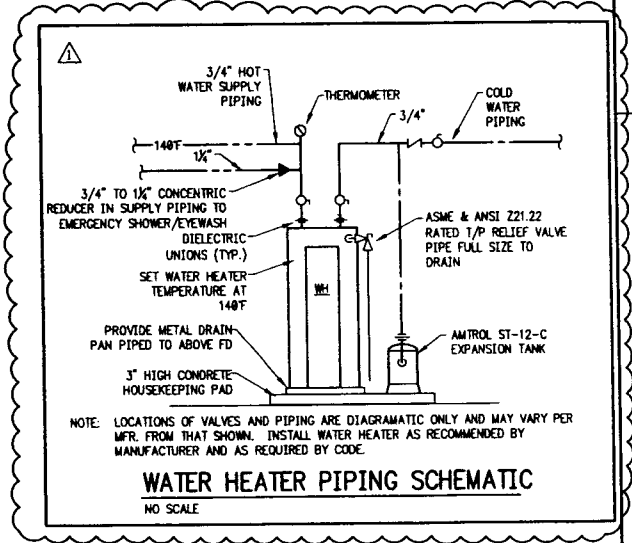

**PLUMBING SCHEDULE, DETAILS & NOTES**



MAIN  
 ISSUE D



FILENAME | 16212  
 SCALE | AS NOTED

SHEET

01P-02





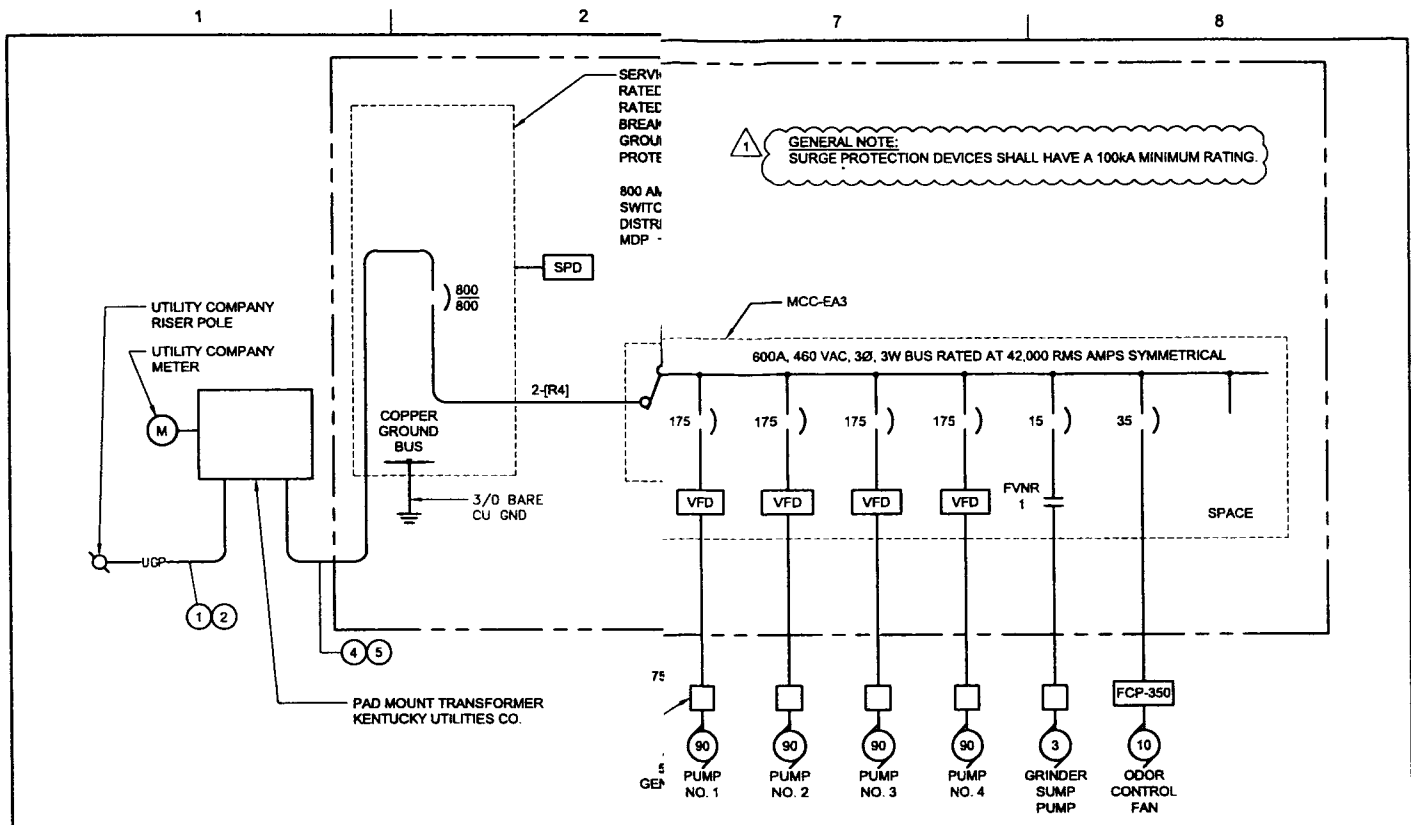

CONDUIT		
TAG NO.	FROM	TO
1	UTILITY COMPANY RISER POLE	PAD MOUNT TRANSFORMER
2	UTILITY COMPANY RISER POLE	PAD MOUNT TRANSFORMER
3	UTILITY COMPANY RISER POLE	ELECTRICAL TELEPHONE
4	PAD MOUNT TRANSFORMER	ELECTRICAL MAIN CIRCUIT
5	PAD MOUNT TRANSFORMER	ELECTRICAL MAIN CIRCUIT
6	AUTOMATIC TRANSFER SWITCH	EMERGENCY GENERATOR
7	AUTOMATIC TRANSFER SWITCH	EMERGENCY GENERATOR
8	ENTRANCE GATE LIGHT FIXTURE	ELECTRICAL PAN
9	FLOW METER VAULT SUMP PUMP RECEP., LIGHT	ELECTRICAL PAN
10	ELECTRICAL ROOM PANEL LP	EMERGENCY ENCL.
11	ELECTRICAL ROOM RTU	EMERGENCY ENCL.
12	ELECTRICAL ROOM AUTO. TRANSFER SW.	EMERGENCY ENCL.
13	FLOW INDICATOR/ TRANSMITTER FIT-202	FEED FLOW ME
14	GENERATOR MAIN CONTROL PANEL	GENERATOR ANNUNCIATION

CONDUIT CALLOUTS	
[3/4] =	[1 1/4" CONDUIT, 2-#14]
[3/4] =	[1 1/4" CONDUIT, 3-#14]
[3/4] =	[1 1/4" CONDUIT, 4-#14]
[3/4] =	[1 1/4" CONDUIT, 5-#14]
[3/4] =	[1 1/4" CONDUIT, 6-#14]
[3/4] =	[1 1/4" CONDUIT, 7-#14]
[1" =	[1" CONDUIT, 8-#14]
[1" =	[1" CONDUIT, 10-#14]
[1" =	[1" CONDUIT, 12-#14]
[1 1/4" =	[1 1/4" CONDUIT, 14-#14]
[1 1/4" =	[1 1/4" CONDUIT, 18-#14]
[3/4" =	[3/4" CONDUIT, 2-#12, 1-#12 GROUND]
[3/4" =	[3/4" CONDUIT, 3-#12, 1-#12 GROUND]
[3/4" =	[3/4" CONDUIT, 4-#12, 1-#12 GROUND]
[3/4" =	[3/4" CONDUIT, 5-#12, 1-#12 GROUND]
[1" =	[1" CONDUIT, 8-#12, 1-#12 GROUND]
[3/4" =	[3/4" CONDUIT, 2-#10, 1-#10 GROUND]
[3/4" =	[3/4" CONDUIT, 3-#10, 1-#10 GROUND]
[1" =	[1" CONDUIT, 6-#10, 1-#10 GROUND]
[E3] =	[1 1/4" CONDUIT, 3-#6, 1-#8 GROUND]
[F3] =	[1 1/4" CONDUIT, 3-#6, 1-#8 GROUND]
[4] =	[2" CONDUIT, 4-#1, 1-#6 GROUND]
[J3] =	[2" CONDUIT, 3-#1/0, 1-#6 GROUND]
[J4] =	[2" CONDUIT, 4-#1/0, 1-#6 GROUND]
[P3] =	[3" CONDUIT, 3-#350 KCM, 1-#1/0 GROUND]
[P4] =	[3 1/2" CONDUIT, 4-#350 KCM, 1-#2 GROUND]
[Q4] =	[3 1/2" CONDUIT, 4-#400 KCM, 1-#1/0 GROUND]
[R4] =	[4" CONDUIT, 4-#500 KCM, 1-#2/0 GROUND]
[S1] =	[3/4" CONDUIT, 1-2/C SHIELDED CABLE]
[S2] =	[3/4" CONDUIT, 2-2/C SHIELDED CABLES]
[S3] =	[1" CONDUIT, 3-2/C SHIELDED CABLES]
[W1] =	[3/4" CONDUIT, CABLE SUPPLIED WITH EQUIP.]
[X1] =	[3/4" CONDUIT, WITH PULL CORD]
[Y1] =	[CABLE SUPPLIED WITH EQUIPMENT]

NOTE: CONDUITS 3, 4, 5, 6, 13 AND 15 TO BE ENCASED IN 01E-10. ALL OTHER CONDUITS TO HAVE SAND BAG



1	9/8/17
---	--------

MAIN

ONE-LINE DIAGRAM AND CONDUIT SCHEDULE

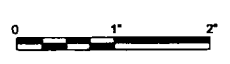

FILENAME | 01E-02.dwg  
SCALE | NONE

SHEET  
01E-02





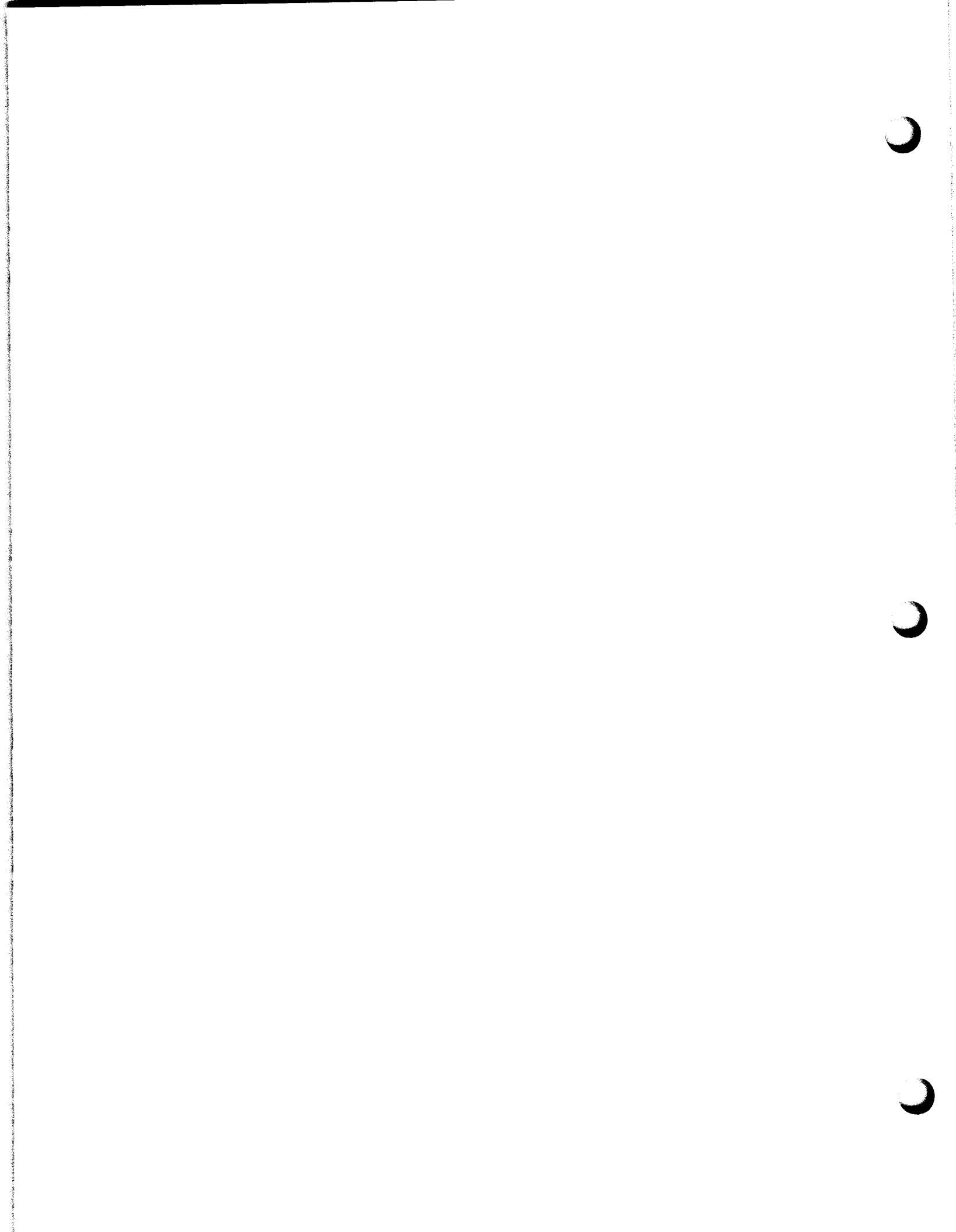

## **SECTION 11421 - MECHANICAL SCREENS AND SCREENINGS COMPACTORS DUPERON**

### **PART 1 - GENERAL**

#### **1.01 SCOPE OF WORK**

- A. Provide all labor, materials, equipment, delivering, installing, testing, and placing into service all mechanical screen and screenings compactor equipment with all appurtenances complete as shown on the Drawings and more fully described hereinafter.
- B. The Contractor shall install a screenings transfer system (chute) between the screens and the screenings compactors, provided by the same manufacturer as the screens and screening compactors. Contractor shall be responsible for properly supporting the screenings transfer system.
- C. The screening equipment and compactors shall be provided complete with all accessories, special tools, spare parts, mountings, anchor bolts and other appurtenances as specified and as may be required for a complete and operating installation. Any modifications or changes to the building, in addition to those shown on the Drawings, necessary to facilitate the screens and screenings compactors shall be the responsibility of the Contractor at no additional cost to the Owner.
- D. It shall be the Contractor's responsibility to install the mechanical screen and screenings compactors and appurtenances with the necessary operating clearances with the structural elements and equipment shown on the Contract Drawings.
- E. Layout, dimensions, and elevations shown on the Drawings are representative of the mechanical screens and screenings compactors. Any costs for re-design, materials, or construction due to requirements of the mechanical screens and screenings compactors equipment ultimately furnished shall be the responsibility of the Contractor.

#### **1.02 RELATED WORK SPECIFIED ELSEWHERE**

- A. Submittals: Section 01300
- B. Operating & Maintenance Manuals: Section 01780

#### **1.03 OPERATING CONDITIONS AND PERFORMANCE REQUIREMENTS**

- A. The mechanical screens shall be designed to remove screenings from raw wastewater and to discharge the screenings into washer compactors. The screens shall be designed for operation in a rectangular channel as shown on the Contract Drawings. Screen shall be a mechanically cleaned bar screen with link system design. The mechanically cleaned bar screen shall have a head sprocket only, with no sprockets, bearings, idlers, or similar drive components under water to trap the chain. Equipment featuring reciprocating rake arms or lower bearings/sprockets/tracks below the water is not acceptable. The design shall be such to ensure that all maintenance can be accomplished at the operating floor level or above. No part of the drive system including sprockets shall be located below the water surface at maximum design flow.
- B. Screening equipment shall be designed to run continuously (24/7), without operator supervision. Screen cleaning system shall be front cleaning and front return design, to prevent the potential of "carry-over" of screenings material.

- C. Debris collected on the bars shall be lifted above deck level by multiple link-mounted scrapers and debris blades. The screenings shall be discharged to a chute connected to the head frame. The chute shall discharge via gravity to the screenings compactors located on the downstream side of the screen. The screen shall consist essentially of the frame, screen field, dead plate, seals, rake assembly (link system, scrapers, debris blades, drive unit, bearing), gearbox, screen drive, local controls and appurtenances specified or otherwise required for a complete and properly operating installation.

#### Mechanical Screens

Parameter	Value
Number of units required	2
Channel width at screen, per screen	3 FT
Channel invert at screen, elevation	896.0
Operating floor elevation (top of channel)	926.5
Maximum upstream water surface elevation (WSEL)	930.0
Minimum screen field width, per screen	2.2
Installed angle, degrees from vertical	75
Flow rate per screen - maximum (peak flow)	10.0 mgd
Flow rate per screen - minimum	10.0 mgd
Max headloss allowable at peak flow, clean screen <sup>(1)</sup>	8.98"
Max headloss allowable at peak flow, 30% blind <sup>(1)</sup>	10.21"
Max head differential across the screen <sup>(2)</sup>	2-ft
Discharge elevation above upper operating floor, minimum	8' (Bar Screen)
Bar spacing (clear space), maximum	0.25 inches
Minimum raking capacity (cf/hr), per screen	5.83 ft <sup>3</sup> /hr
Rake travel speed (feet per minute)	Low Speed: 23 ft/min. High Speed: 46 ft/min.
<sup>(1)</sup> Headloss calculation(s) shall be based on the assumption that the water depth within the channel downstream of screen equals 2.0 ft	
<sup>(2)</sup> All components, including the gear reducer, shall be designed to withstand, without damage or permanent distortion, the maximum headloss allowable (full screen blinding).	

- D. The heavy duty screw type screenings washer compactor shall be suitable for installation and operation with the screen and shall accept screenings, compress and dewater them and deliver them to the screenings dumpster as shown on the Drawings. The screenings compactor shall also be equipped with a washing zone. The screenings washer compactors shall be provided by the same manufacturer as the screens and shall be connected to the screens by a covered chute as specified herein.

#### Screenings Compactor

Parameter	Value
Number of units	2
Number of hopper inlets per unit	1
Screw length, minimum (ft)	26 ft and 34.9 ft
Minimum capacity (cf/hr), total	Maximum 133 ft <sup>3</sup> /hr
Feed concentration, % dry solids content	0 - 5 %
Compactor discharge concentration, % dry solids content	25 - 30 %
Minimum screenings volume reduction, %	35 - 40 %
Minimum screw diameter, inches	11 - 1/4"
Maximum screw rotational speed, rpm	15 rpm

#### 1.04 MANUFACTURER

- A. The mechanical screen and screenings compactor units shall be provided by a single manufacturer with a minimum of ten (10) years' experience in designing and manufacturing screening equipment of similar type, size and capacity. The mechanical screens and screenings compactors shall be manufactured by Duperon Corporation or approved equal.
- B. To assure unity of responsibility, the mechanical screens and screenings compactors, chute, controls, motors, VFDs, gearboxes, and appurtenances specified and other auxiliary equipment, and materials specified in this Section shall be furnished and coordinated by the screen manufacturer (Manufacturer) who shall assume responsibility for the satisfactory operation of the entire screening system.
- C. Replacement Parts Capability: The manufacturer shall have the ability to promptly furnish any and all interchangeable replacement parts as may be needed at any time within the expected life of the equipment. Upon request, the Contractor shall submit evidence of the proposed manufacturer's ability to promptly fill replacement orders.
- D. Quality Assurance: All screening equipment shall be of approved design and make products of manufacturers who have built equipment of similar type, size and capacity. Upon request, the Manufacturer shall provide evidence of at least five (5) installations in which similar sized equipment has provided satisfactory performance for a minimum of five (5) years in a similar application.
  - 1. The Contractor shall obtain the screening equipment, controls and appurtenances from the screen manufacturer, as a complete and integrated package to insure proper coordination and compatibility and operation of the system.
  - 2. All components made of stainless steel shall meet the acid passivation requirements of ASTM A380. Stainless steel components shall be fabricated in a manner to prevent contamination with carbon steel.
  - 3. Provide fabrication in compliance with all applicable ASTM standards or equivalent international standards.
  - 4. The equipment manufacturer's shop welds, welding procedures, welders and welding operators shall be qualified and certified in accordance with the requirements of the latest edition of ANSI/AWS D1.6 "Structural Welding Code - Steel" published by the American Welding Society or equivalent standard.
  - 5. Perform all welding in the factory using shielded arc, inert gas, MIG or TIG method. Add filler wire to all welds to provide for a cross section and weld metal equal to or greater than the parent metal. Fully penetrate butt welds to the interior surface and provide gas shielding to interior and exterior of the joint.
- E. Additional Submittals: The Contractor shall submit, upon request, any additional information that the Engineer may deem necessary to determine the ability of the proposed manufacturer to produce the specified equipment.
- F. Manufacturer Information: All manufacturer information required by the specifications shall be submitted by the Contractor within thirty (30) calendar days of the date of receipt of the Notice to Proceed.

Any additional information or data, specifically requested by the Engineer, concerning manufacturer's capabilities (especially relating to requirements described hereinbefore), shall be submitted by the Contractor within fourteen (14) calendar days of the receipt of the written request thereof, unless otherwise specified.



Approval of manufacturers or suppliers will not be given until all information required by the specifications or requested by the Engineer has been submitted and acceptable.

**G. Disqualification of Manufacturer:**

1. Poor performance of similar screening equipment now in operation under the specified conditions of service and screen rating constitute grounds for disqualification of the screen manufacturer, supplier, or both, unless such poor performance has been corrected.
2. Failure to successfully comply with the provisions of subparagraphs A through G, inclusive, will constitute grounds for disqualification of screen manufacturer.

**1.05 SUBMITTALS (SHOP DRAWINGS)**

- A. General: The Contractor shall comply with the provisions of the specifications regarding submittals, unless otherwise specified herein.
- B. At the time of submission, the Contractor shall, in writing, call the Engineer's attention to any deviations that the submittals may have from the requirements of the Engineer's Contract Drawings and Specifications.
- C. The Contractor shall provide a notarized certification indicating that all screening products meet the required Specifications.
- D. Descriptive literature shall be submitted on all items specified herein to the Engineer for review and approval before ordering.
- E. Content of Submittals: The following shall be included in submittals as a minimum. However, any additional information or data shall be added if and whenever requested by the Owner or the Engineer. Where applicable, submit separate data for each mechanical screen and screenings compactor.
  1. Descriptive Literature:
    - a. Equipment dimensions and weight.
    - b. Materials of Construction (including required coating).
    - c. Complete motor nameplate data as defined by NEMA.
    - d. Gear reducer data including service factor, efficiency, torque rating and materials.
    - e. Shop drawing data for accessory items.
    - f. Certified setting plans, with tolerances, for anchor bolts.
    - g. List of recommended spare parts other than those specified.
    - h. Shop and field inspection reports.
    - i. Qualifications of field service engineer.
    - j. Recommendations for short and long-term storage.
    - k. Shop and field testing procedures, set up and equipment to be used.

- l. Special tools.
        - m. Schematic control and power wiring diagrams including interconnecting and internal wiring diagrams.
        - n. Control panel drawings and heat load / dissipation calculations.
        - o. Manufacturer's literature as needed to supplement certified data.
2. Installation Information: Submit installation drawings and information for pump connections, connecting piping and valves, electrical connections, and auxiliary equipment.

The Contractor shall submit all other drawings, material lists and other information specified, requested and/or necessary to show complete compliance with all details of the contract documents.

3. Operation and Maintenance Manual: Manual shall contain all information necessary for proper operation and maintenance of mechanical screens and screenings compactors units, as well as the location of the nearest permanent service headquarters.

F. Calculations:

1. Maximum headloss and velocity at peak flow for clean screens.
2. Maximum headloss and velocity at peak flow for 30% blinded screen conditions to verify screens can handle peak flows.
3. Structural calculations of screen design strength to handle the maximum head differential across the screens (maximum water level upstream and no water downstream) to verify screens can handle full blinded conditions.
4. Calculations shall be signed and sealed by a Professional Engineer.

## 1.06 TESTS

A. Shop Tests:

1. All equipment shall be tested in the shop of the manufacturer in a manner which shall conclusively prove that its characteristics comply fully with the requirements of the Contract Documents and that it will operate in the manner specified or implied.

B. Field Tests:

1. The field tests shall be made on each mechanical screen and screenings compactor unit by the Contractor in the presence of and as directed by the Engineer.
2. The Contractor shall give at least two (2) week's notice to the Owner and Engineer when the field tests are to be accomplished so that the Owner and Engineer may have a representative present at the said tests.
3. Before any screening equipment is rotated, the Contractor shall make certain that no debris is present in screening channels. Any damage done to equipment while starting up shall be assumed to be caused by debris and shall be replaced at the Contractor's expense.

4. During the test, the screening equipment shall be checked for proper alignment of the rake and bar screen, operated at maximum rated speed to confirm smooth operation and no undue noise, vibration, overheating or overloading of drive motors and components. Controls shall be checked to verify screening equipment operates as specified. Safety interlocks and devices shall be checked for proper operation.
5. Contractor shall be responsible for making all adjustments necessary to place equipment in specified working order at time of above tests.
6. Field tests shall also conform to Part 3, Paragraph 3.03 as specified hereinafter.

**C. Failure of Tests:**

1. Any defects in the equipment or failure to meet the guarantees or requirements of the specifications shall be promptly corrected by the Contractor by replacements or otherwise. The decision of the Engineer as to whether or not the Contractor has fulfilled his obligations under the Contract shall be final and conclusive. If the Contractor fails or refuses to make these corrections or if the improved equipment, when tested, shall fail again to meet the guarantees of specified requirements, the Owner notwithstanding its having made partial payment for work and materials which have entered into the manufacture of said equipment, may reject said equipment and order the Contractor to remove it from the premises at his own expense.
2. In case the Owner rejects said equipment, then the Contractor hereby agrees to repay to the Owner all sums of money paid to him for said rejected equipment on progress certificates or otherwise on account of the lump sum prices herein specified, and upon the receipt of said sum of money the Owner will execute and deliver to the Contractor a bill of sale of all its rights, title, and interest in and to said rejected equipment; provided, however, that said equipment shall not be removed from the premises of the Owner until the Owner obtains from other sources the equipment to take the place of the rejected. The Owner hereby agrees to obtain said other equipment within a reasonable time and the Contractor agrees that the Owner may use the equipment furnished by him without rental or other charge until said other new equipment is obtained.

**D. Responsibility During Test:** The Contractor shall be fully responsible for the proper operation of equipment during tests and instruction periods and shall neither have nor make any claim for damage which may occur to equipment prior to the time when the Owner formally takes over the operation thereof.

**E. Manufacturer's Representative:** For all screening equipment, the Contractor shall furnish the services of accredited representatives of the equipment manufacturer who shall supervise the installation, adjustment, and field tests of each screening unit and give instructions to the operating personnel. As one condition necessary to acceptance of any screening equipment, the Contractor shall submit a certificate from the manufacturer, stating that the installation of the equipment is satisfactory, that the unit is ready for operation, and that the operating personnel have been suitably instructed in the operation, lubrication, and care of the unit.

**1.07 GUARANTEE PERIOD**

- A. After successful completion of tests and trials under operating conditions on all equipment, the Contractor shall guarantee all equipment, materials and workmanship from undue wear and tear, from mechanical and electrical defects, and from any failure whatever, for a minimum of one (1) year. This one (1) year minimum shall not replace a standard manufacturer's guarantee if it exceeds one (1) year.

**1.08 WARRANTY**

- A. The Contractor guarantees and warrants that during the first one year of operation, the mechanical screens and screenings compactors will operate satisfactorily and continuously according to the operating conditions and performance requirements specified herein, and that after due notice has been given by the Owner, he or the equipment manufacturer will proceed, within a reasonable time, to adjust, regulate, repair and renew at his own expense or perform such work as is necessary to maintain the guaranteed capacities, efficiencies and performances.

## **PART 2 - PRODUCTS**

### **2.01 MECHANICAL SCREENS**

A. Frame:

1. Framework of screen shall be constructed of 304 stainless steel bent plate with minimum of 3/16" cross section. Horizontal members shall be of 304 stainless steel bent plate with a minimum thickness of 3/16". The side frames shall be connected to the support frames. The support frames shall be securely anchored to the operating floor. A 304 stainless steel channel bottom plate shall be an integral part of the bar screen assembly to fully engage scrapers in the bar screen at the base of the unit and assure that the raking mechanism reaches the bottom of the screen to prevent debris accumulation. The minimum bottom plate thickness shall be 3/16". No braces, gussets or stiffeners shall be inside the Screen Frame that will allow for screenings to collect
2. All parts shall be designed and manufactured to handle the forces that may be exerted on the screen during fabrication, shipping, erection, and proper operation according to the Operation and Maintenance Manual. All components shall be so designed that jamming at any point will not result in structural failure, but will cause the drive motor to stall. All components, including the gear reducer, shall be designed to withstand, without damage or permanent distortion, the full stalling torque of the drive motor.
3. Frame width and height shall be customized to fit the specified channel dimensions, discharge height, and hydraulic force requirements. The mechanical screen assembly shall be shipped in one piece. Screen construction shall allow for disassembly in the event modular construction is required.
4. The unit shall be supported and anchored on the operating floor and rest on the bottom of the channel.
5. Anchor bolts shall be a minimum 3/8" diameter furnished by the Contractor. Bolts and nuts shall be of Type 304 stainless steel. Anti-galling compound shall be used to assemble all stainless steel nuts, bolts and fasteners.
6. Stainless steel backing plates will be mounted along the upstream edges of the frame to seal the outer edge of the frame against the channel walls.
7. The bottom seal shall consist of a neoprene seal to prevent the flow from passing under the screening.
8. Link slide assembly shall be provided per manufacturer standard design and shall be constructed of UV Stable UHMW PE rollers and 304 stainless steel supports and components.
9. Screen enclosure / covers which are easily removable shall be provided with handles and turn locks for "no tool required" access. A 14 gauge. (minimum thickness) #4 brushed satin finish 304 stainless steel enclosure shall be installed to cover the screen above the

operating deck level. Front Enclosure shall have continuously hinged stainless steel doors with polycarbonate viewing pane for access to equipment. Removable panels shall be constructed of 304 stainless steel with a minimum thickness of 16 gauge. Alignment notches shall be included to support repositioning of removable panels. Rear Enclosure shall have hinged removable doors and shall be secured with a lift-slide-latch handle. Rear removable door shall include an integral viewing door that shall be secured with a lift-slide-latch handle to provide access for a quick look inside.

**B. Screenfield and Deadplate:**

1. Screen bars shall be constructed of 304 stainless steel and be "tear-shaped" with a hydraulic coefficient shape factor of 0.76 and the minimum dimensions of 0.25 inch x 0.75 inch x 0.13 inch.
2. Bars shall be supported from framework and shall be individually replaceable without welding or cutting. Replacement screen bars shall be available from the screen manufacturer.
3. There shall be no space wider than the opening between the bars which would permit passage of larger solids through the screen.
4. Dead plate of 304 stainless steel plate (minimum thickness is ¼") shall be flat and true; span the entire width of the unit; transition from bar screen and extend to the discharge point.

**C. Screen Cleaning:**

1. The equipment shall have multiple scrapers on the bar screen at one time cleaning continuously from bottom to top, the entire width of the bar screen. Units which have single raking arms or that require cycle times shall not be allowed.
2. Manufacturer's equipment shall have a head sprocket only, with no sprockets, bearings, idlers, or similar drive components under water to trap the chain. Equipment featuring reciprocating rake arms or lower bearings/sprockets/tracks below the water is not acceptable.
3. The link system shall have jam evasion capability by flexing around and collecting large objects such as a 2 X 4 board, bowling ball, grease balls and surges of solids at peak loading times without overloading and shutting down the unit. The link system shall be such that it bends in one direction only which allows it to become its own lower sprocket and frame and shall have a 1,000 pound lifting capacity.
4. The link system shall be stainless steel castings and have a minimum ultimate strength of 60,000 lbs with a minimum cross section of 1.5 inches and weighing a minimum of 4.5 lbs each. Links and pins shall be constructed of 304 stainless steel material. Retaining rings shall be constructed of 302 stainless steel.
5. Scrapers shall be spaced 21 inches apart. To provide long product life the scraper shall move at no greater than 28 inches per minute at standard operating speed of ½ rpm allowing for approximately 1 debris discharge per minute. Staging Scrapers and Thru Bar Scrapers shall be a maximum ratio of 3:1 per manufacturer recommendations. At least one scraper every 84 inches shall fully penetrate the bar screen, cleaning all three sides of the bars as well as through to the cross members in openings of 0.25, 0.375 and 0.50 inches.
6. Staging Scrapers shall be 1 inch thick x 5 inches x screen width UV Stable UHMW-PE with a serrated edge.

7. Thru Bar Scrapers shall be minimum 0.375 inch thick 304 stainless steel.
8. A 304 stainless steel and UV Stable UHMW-PE debris blade assembly, which does not require a separate drive, shall be installed to assist in removing debris from the scraper on the mechanically cleaned bar screen unit as recommended by the manufacturer.
9. Return guide/Closeouts shall be 304 stainless steel and shall assure proper alignment of scrapers as they enter the bar screen and assure that there is no space wider than the clear opening between bars to prevent passage of larger solids than allowed through the screen.
10. Screenings transported to the top of the screen shall be discharged positively by means of a scraper mechanism to the discharge chute. Cleaning mechanisms that utilize shock absorbers, springs, or other dampening or hydraulic actuators are unacceptable.
11. A discharge chute shall be provided for each screen to divert screenings discharged from the screen to a screenings compactor. The discharge chute shall be constructed of 304 stainless steel with a minimum thickness of 11 gauge. The discharge chute shall be bolted to the dead plate.

D. Drive Mechanism:

1. The Drive Head shall be located at the top of the mechanically cleaned bar screen. The drive mechanism for the rakes shall incorporate a solid shaft constructed of AISI 1018 steel or Type 304 stainless steel. The drive shaft shall have a minimum diameter of 3-1/8 inch. The drive output shaft rotation shall be constant and in one direction in order to reduce maintenance and increase product life.
3. Drive Sprockets shall be coated ASTM A48, CL40 cast iron with ASTM A536 80-55-06 ductile cast iron end castings.
5. All ball or roller bearings shall be L 10 rated and manufactured by a member of the Antifriction Bearing Manufacturer's Association for 100,000 hour life (minimum). At least one bearing on each shaft shall be of the combined radial and thrust type.
6. The rake mechanism shall be capable of 2 cleaning speeds. Normal (slow) speed shall have between a 10 to 15 second cleaning interval (between rakes) and high (fast) speed shall have between a 5 to 10 second cleaning interval.

E. Speed Reducer:

1. Speed reducers shall shaft mounted and shall be of the cycloidal and spiral bevel gearing type fully enclosed in a weatherproof casing of cast iron or welded steel. Reducers shall have ball or roller bearings throughout with all moving parts immersed in oil. Shafts shall be of high strength alloy steel ground to required tolerances. Bevel gearing shall be in compliance with ANSI/AGMA Standards 2003-A86 and shall be carbonized to a hardness of 58-62 HRC for durability. All ball or roller bearings shall be L 10 rated and manufactured by a member of the Antifriction Bearing Manufacturer's Association for 100,000 hour life (minimum). At least one bearing on each shaft shall be of the combined radial and thrust type.
2. Reducer units shall meet the standards of the American Gear Manufacturers Association for such equipment under moderate shock, 24 hour, Class II service with a service factor of 1.25 (minimum) and an AGMA rating plate showing compliance shall be affixed to each unit. The output capacity of the speed reducer shall be equal to the motor horsepower less reducer losses.

3. Speed reducers running on a positive circulation of lubricating oil shall have sight windows for inspection of oil flow. A drain shall be provided in each casing. A sight glass shall be provided such that oil level may be inspected from operator access level. The gearbox shall not be vented to the outside atmosphere.
4. All seals shall be double lip, spring-loaded type and made of nitrile rubber.
5. Speed reducers and motors requiring coupling shall be coupled by means of approved all metal flexible couplings, furnished and installed complete with coupling guards, if not otherwise guarded.

## 2.02 SCREENINGS COMPACTORS

- A. The screenings compactor shall be of the dual auger design. The system shall be designed to receive, wash, positively convey and compact screenings discharged from the mechanical screen(s). The compactor shall be capable of continuous operation and of handling all wastewater screenings received from the mechanical screen, in addition to the washer compactor's wash water flows. Compactor shall have the ability to process multiple pieces of clothing, variable volumes of debris, and unprocessed septage or grease. Compactor shall be equipped with a self-regulating, active pressure zone designed to accept non-standard wastewater debris in its original form, such as rocks, broken concrete, and metal (bolts, short pipe, etc.) up to 4 inches long. Manufacturer shall provide calculations to show the screenings compactor is sufficiently sized to convey the maximum amount of screenings that the screening equipment can deliver.
- B. The screenings shall be introduced into the inlet hopper directly over the Sieve Zone, washed in the Wash Zone, compacted in the Press Zone, conveyed through the Transport Zone, and discharged from the Discharge Tube into a suitable receptacle. The excess liquid shall drain through holes in the inlet trough.
- C. Each compactor shall be designed to handle capacity per paragraph 1.03. The compactor shall reduce screenings volume by a minimum of 50% and produce dry screenings content per paragraph 1.03.
- D. Unless specified otherwise hereinafter, stainless steel shall be grade 304. All mechanical parts shall be designed to handle the forces that may be exerted on the Washer Compactor during fabrication, shipping, erection, and operation.
- E. Augers (shafted screw assemblies):
  1. Dual augers shall provide positive displacement action, be orientated on top of each other and rotate in opposing directions. The augers shall be intermeshed and shall be of 1 left hand and 1 right hand lead.
  2. Augers shall be constructed of 304 stainless steel with flights welded to a solid shaft. Minimum thickness of Auger flights shall be 3/8 inch with 4 inch flight pitch.
  3. Augers shall float mounted in a UHMW thrust and plane bearing arrangement that allows movement for accommodation of irregular debris. Stainless steel fasteners shall be provided to hold the auger support in place.
- F. Frame / Housing:
  1. The compactor housing shall be constructed of 304 stainless steel with a minimum thickness of 11 gauge and connect to 3/8 inch thick flanges.

2. Housing shall be furnished with minimum ½ inch diameter water supply line connection fitting. Wash port manifold shall be integrated prior to the compaction housing and delivers 3 to 5 GPM. The Washer Compactor manufacturer shall provide all solenoid valves and isolation valves, required to control the flow of wash water. All interconnecting piping, valves, etc. between the water source, and Washer Compactor housing and the solenoid and isolation valves shall be supplied and installed by the Contractor.
3. Drain connection shall be 3 inch NPT (minimum).
4. Rear leg, front leg and intermediate leg supports, as required, shall be furnished for rigid support to the concrete slab. Anchor bolts shall be a minimum ½ inch diameter 304 stainless steel furnished by the Contractor. Anti-galling compound shall be used to assemble all stainless steel nuts, bolts and fasteners.

G. Discharge Tube:

1. Discharge Tube shall be constructed of minimum 14 gauge 304 stainless steel. The discharge tube shall increase in diameter/size over its length in order to reduce the potential for plugging.
2. Discharge Tube shall direct and discharge screenings at a clear discharge height that allows for placement of a dumpster (provided by Owner) to collect the screenings.
3. Supports shall be furnished, as required for rigid support of the tubing to the concrete slab.

H. Bagging System:

1. Cassette Holder shall be constructed of 304 stainless steel and ABS Plastic with a continuous bagger cassette, 230 ft (80 meters) in length, minimum.

I. Speed Reducer:

1. Speed reducers shall be of the helical or bevel gear type fully enclosed in a weatherproof casing of cast iron or welded steel. Reducers shall have ball or roller bearings throughout with all moving parts immersed in oil. Shafts shall be of high strength alloy steel ground to required tolerances. Bevel gearing shall be in compliance with ANSI/AGMA Standards 2003-A86 and shall be carbonized to a hardness of 58-62 HRC for durability. All ball or roller bearings shall be L 10 rated and manufactured by a member of the Antifriction Bearing Manufacturer's Association for 100,000 hour life (minimum). At least one bearing on each shaft shall be of the combined radial and thrust type.
2. Reducer units shall meet the standards of the American Gear Manufacturers Association for such equipment under moderate shock, 24-hour, Class II service with a service factor of 1.4 (minimum) and an AGMA rating plate showing compliance shall be affixed to each unit. The output capacity of the speed reducer shall be equal to the motor horsepower less reducer losses.
3. Speed reducers running on a positive circulation of lubricating oil shall have sight windows for inspection of oil flow. A drain shall be provided in each casing. A sight glass shall be provided such that oil level may be inspected from operator access level.
4. Speed reducers and motors requiring coupling shall be coupled by means of approved all-metal flexible couplings, furnished and installed complete with coupling guards, if not otherwise guarded.

J. Safety Devices and Limit Switches:



## 1. Safety Trip Cords

- a. Each screw compactor shall be furnished with safety trip cords running on all sides of the hopper inlet with a safety stop switch in compliance with OSHA standards.
- b. Trip cabling shall be stranded galvanized aircraft cable and orange colored nylon outer sheathing. Cabling shall be supported by stainless steel eyebolts every 4 feet. Wire clamps shall be stainless steel.
- c. Safety switch shall be housed in a NEMA 7 enclosure and shall have 2 SP/DT micro-switch and stainless steel external hardware. Switch shall be maintained once activated and shall require a manual reset.
- d. If a trip cord signal is received from the safety trip cord switch, when the motor is running, the compactor shall alarm and stop.
- e. Emergency trip cord and safety switch shall be Conveyor Components Company Model RS-2X, or equal.

## 2. Zero Speed Switch

- a. Provide non-contacting, proximity-type speed switch on the screw press to detect zero speed condition. The zero speed switch shall consist of a sensor with internally mounted pre-amplifier and a transmitter output unit. The switch shall be located on the non-driven end.
- b. The sensor shall utilize magnetic proximity effect to detect equipment rotational speed without physical connection to the rotating equipment. Sensors shall provide output pulses in proportion to rotational speed by detection of the rotating flights of a screw press assembly. The sensor shall operate satisfactorily with air gaps of up to 4". The sensor/pre-amplifier shall be provided complete with mounting flange, threaded body, locknut, and ferrous mass of mounting on screw flight.
- c. The amplifier/output switch unit shall provide two SPDT contacts that operate on detection of an under speed operating condition. The SPDT contact outputs shall be rated for 5A at 120 volts AC. The unit shall include an adjustable start-up delay of 0 to 60 seconds to override zero speed alarm during initial acceleration. Units shall operate on 120 volt AC power. Provide set point adjustment range of 2 to 3,000 pulses per minute.
- d. If a zero speed signal is received from the zero speed switch, when the motor is running, the compactor shall alarm and stop.
- e. Zero speed detection switches shall be Milltronics MFA-4P with Milltronics XPP-5 sensor, or equal.

## 2.03 ELECTRICAL AND CONTROL REQUIREMENTS

- A. All electrical appurtenances, with the exception of the control panel, furnished by the equipment manufacturer shall be rated for installation in a Class I, Division 1 hazardous location within the screenings areas.
- B. All conduit, couplings, fittings, and fasteners furnished by the equipment manufacturer shall be rigid aluminum and liquid tight, PVC coated, flexible metal conduit rated for the conditions noted.

C. Electrical Requirements:

Motors	Screens	Screenings Compactors
VFD	Yes	No
Rating	460V, 3 ph, 60 Hz	460V, 3 ph, 60 Hz
Horsepower, Max	5	5
Speed, rpm	1800	1800
Enclosure	TEFC-XP	TEFC-XP
Insulation	Class H	Class H
Inverter Duty	Yes	No
Service Factor	1.0	1.15
Space Heater	No	No
Motor Winding Temperature Switch	No	No

**2.04 VARIABLE FREQUENCY DRIVES**

- A. The speed control for variable speed pumps shall be Variable Frequency Drives, as specified in Division 16 suitable for installation as shown on the Drawings.
- B. The Variable Frequency Drives shall be supplied by the Manufacturer and shall be completely coordinated with the pumps and pump driving motors and shall include all internal auxiliaries required to meet the functional specifications.
- C. The Variable Frequency Drives shall be compatible with the motors provided by the Manufacturer.

**2.05 CONTROL PANELS**

- A. Each screen and each compactor shall be provided with a separate Local Control Station (LCS) located at the equipment. Controls for each LCS shall include the following features:
  - 1. NEMA 7 rating suitable for a Class I, Division 1 hazardous location.
  - 2. Screen LCS shall have FORWARD and JOG-REVERSE pushbuttons and a maintained-type mushroom-head emergency stop button.
  - 3. Compactor LCS shall have RUN and JOG-REVERSE pushbuttons and a maintained-type mushroom-head emergency stop button
  - 4. In addition each compactor shall have a remote Emergency Stop Station (LLCS).
- B. Each screen shall be supplied with a combined Screen/Compactor Local Control Panel (CP) to be located away from the equipment in the electrical room. These CP shall be vendor furnished and shall include the following features:
  - 1. In addition each compactor shall have a remote Emergency Stop Station (LLCS).
  - 2. Each CP shall be painted steel and rated NEMA 12 suitable for unclassified locations. Panel shall be supplied with a flange mounted disconnect switch and main circuit breaker. Power supply to panel shall be 480VAC, three phase, 60Hz AC.

3. A variable frequency drive (VFD) shall be provided in the LCP for control of the screen drive system. VFDs shall be as specified in Section 16446, Variable Frequency Drives.
4. Design of the control panel shall be with 120VAC logic.
5. For each bar screen, dual input Ultrasonic level indicating transmitters (LITs) as manufactured by Siemens shall be provided, these transmitters shall be mounted inside the CPs. Two ultrasonic level transducers shall be provided for each bar screens, refer to contract drawings for mounting location. Refer to Division 17 for additional requirements.
6. Programmable Logic Controllers (PLC) shall be furnished for an integrated PLC-based control system. The PLC shall be Allen-Bradley CompactLogix series furnished in accordance with Section 17311.
7. The supplier shall furnish an integrated PLC-based control system to monitor and control the operation of each screen and screenings compactor.
8. Front panel devices, at a minimum, shall include as a minimum an Allen-Bradley PanelView Plus 6 1000 Operator Interface Terminal (OIT), Control Power On (blue indicating lamp), Emergency Pushbutton (mushroom type), and a non-resettable mechanical elapsed time meter.
9. The OIT shall display the process and equipment using a graphic representation of the actual screen/compactor system. It shall display all parameters being monitored including alarms. Also, allow for adjustment of timers and set points by the operator. The graphic screens shall be tailored specific to this project.
10. All the PLC adjustable set points and control parameters shall be through the OIT.
11. The PLC shall have an Ethernet port and connect to the RTU- ESPS panel to allow control and set point adjustment from remote.
12. The Supplier shall coordinate with Instrumentation and control system subcontractor for addressing and tagging.
13. Discrete Inputs (from remote dry contact):
  - a. Screen Level High (override from level float switch)
  - b. Screen LCS Auto
  - c. Screen LCS Forward
  - d. Screen LCS E-Stop
  - e. Compactor LCS Auto
  - f. Compactor LCS Forward
  - g. Compactor LCS E-Stop
  - h. Compactor Pull Cord activated
  - i. Compactor Fail
  - j. System Enable (from plant PLC)
  - k. Level High Differential (from level transmitter)

- I. Level High-High Differential (from level transmitter)
- C. Discrete Outputs (rated 5A @ 120VAC):
    1. Screen Switch In Auto (to pump station PLC)
    2. Screen Running at Low Speed (to pump station PLC)
    3. Screen Running at High Speed (to pump station PLC)
    4. Screen Common Fault (to pump station PLC)
    5. Compactor Switch In Auto (to pump station PLC)
    6. Compactor Running (to pump station PLC)
    7. Compactor Common Fault (to pump station PLC)
  - D. Analog Inputs (4-20mA):
    1. Screen channel upstream Level
    2. Screen channel downstream Level
  - E. All other equipment manufacturer recommended safety alarms shall be included.
  - F. All accessories and appurtenances required for a complete and operational system shall be provided. Refer to division 17 for additional requirements.
  - G. SCREEN CONTROL OPERATIONS:
    1. The Bar Screens shall operate in the manual and automatic mode. In the manual mode initiated by the operator and in the automatic mode based on channel differential level and repeat cycle timers.
    2. Each LCS includes the following selector switches a Hand/Off/Remote (HOR) switch a Forward/Off/Reverse-Jog (FOR) switch, and an Emergency Stop Pushbutton Switch.
    3. When the Hand/Off/Remote (HOR) switch on the LCS is in the hand position, the screen shall be controlled from the LCS as follows:
      - a. When the FOR selector switch on the LCS is in the Forward position, the screen shall run in the forward direction at slow speed.
      - b. When the FOR selector switch on the LCS is in the Off position, the screen shall not run.
      - c. When the FOR selector switch on the LCS is held in the Reverse position, the screen shall run in the reverse direction.
    4. When the HOR switch on the LCS is in the Off position, the screen shall not run.
    5. When the HOR switch on the LCS is in the Remote position, the screen shall be controlled from the OIT at the CP as follows:
      - a. When the On/Off/Auto (OOA) System Enable selector on the CP OIT is in the On position, the screen shall run.

- b. When the OOA System Enable selector on the CP OIT is in the Off position, the screen shall not run.
- c. When the OOA System Enable selector on the CP OIT is in the Automatic position, the screen shall cycle on and off based on the repeat cycle timer or level mode based on the differential level. The repeat cycle timer shall be adjustable from the OIT (initially set at 60 minutes) during the repeat cycle the screen shall run for a predetermined time span (initially set at 15 minutes) one screen run continuously at slow speed, as configured on the VFD drive or PLC. In the automatic mode the high differential level set point (adjustable from the OIT) will override the automatic timer control, and start the screen and shall run in fast speed, as configured on the VFD or PLC drive.

Upon detection of a jam, by high motor current, the screen shall attempt to dislodge the item by alternating and reversing the motor a preset period of time before stopping and alarming. Upon overload the screen shall alarm and shutdown.

#### H. COMPACTOR CONTROL OPERATIONS:

1. When the HOR switch on the LCS is in the Hand position, the compactor shall be controlled from the LCS as follows:
  - a. When the Forward/Off/Reverse (FOR) selector switch on the LCS is in the Forward position, the compactor shall run in the forward direction.
  - b. When the FOR selector switch on the LCS is in the Off position, the compactor shall not run.
  - c. When the FOR selector switch on the LCS is held in the Reverse position, the compactor shall run in the reverse direction
2. When the HOR switch on the LCS is in the Off position, the compactor shall not run.
3. When the HOR switch on the LCS is in the Remote position, the compactor shall be controlled from the OIT at the CP as follows:
  - a. Sequence of operation for compactor is initiated based on the run time of the associated screen. The compactor shall run whenever the associated screen is in operation. The compactor start, initiates a wash cycle.
  - b. Wash cycle:
    - 1) Wash water supply is activated: ON/OFF mode with adjustable timers for each operational condition
    - 2) Drive runs forward also controlled by timers with adjustable ON/OFF sequence
    - 3) Wash cycle is followed by discharge cycle: screw is running forward for an adjustable time
    - 4) Pan wash is activated
    - 5) Wash cycle finished
  - c. The screen, compactor, spray, and all spray washes shall alarm and stop immediately if any of the e-stop pushbuttons are pressed.

- d. Compactor shall have the ability to clear blocking automatically: if current monitoring relay senses high load condition the screw stops and a clearing cycle is initiated: the screw stops immediately and reverses (time is adjustable at operator interface) and starts running forward. The number of attempts to clear the blocking is also adjustable – if screw is not cleared after allowed number of attempts or the overload is sensed during reversing, the system stops immediately and an alarm signal is rendered. Compactors shall also be furnished with over-torque and overload safety devices.

## 2.06 SPARE PARTS

- A. The Contractor shall furnish all special tools (one per like piece of equipment) necessary to disassemble, service, repair and adjust the equipment.
- B. The Contractor shall furnish spare parts as recommended by the equipment manufacturer in addition to those listed below.
- C. Equipment General Provisions and shall include the following at a minimum:
  - 1. Mechanical screens (per screen)
    - a. One (1) Drive Clevis Pin
    - b. Four (4) Link Clevis Pins
    - c. Ten (10) Snap/Retaining Rings and Tool
    - d. Four (4) Scraper Nuts
    - e. Four (4) Scraper Bolts
    - f. One (1) Snap Ring Tool
    - g. One (1) "Never Seez" Lubricant (3 oz. Tube)
    - h. One year supply of all recommended lubricants
  - 2. Screenings Compactors (per compactor)
    - a. One (1) Plane Bearing Kit
    - b. One year supply of all recommended lubricants
    - c. Three (3) Continuous bagger cassettes
  - 3. Control Devices
    - a. Two of all relay, timer or control device used in the system
    - b. Two sets of spare fuses for each type used in the system
    - c. One indicating lamp for each type used in the system

## PART 3 - EXECUTION

### **3.01 PREPARATION**

- A. Coordinate with other trades, equipment and systems to the fullest extent possible.
- B. Take all necessary measurements in the field to determine the exact dimensions for all work and the required sizes of all equipment under this contract. All pertinent data and dimensions shall be verified by the Contractor.

### **3.02 INSTALLATION**

- A. Installation shall be in strict accordance with the manufacturer's instructions and recommendations in the locations shown on the Drawings. Anchor bolts shall be set in accordance with the manufacturer's recommendations and setting plans.
- B. The Contractor shall also provide from the manufacturer the service of a qualified start-up engineer (factory representative) who has had prior on-site start-up experience to assist in performing start-up, checkout and initial operation services of screening equipment. The start-up engineer shall also instruct the Owner's personnel on the operation and maintenance procedures for the station. Qualified supervisory services, including manufacturers' engineering representatives, shall be provided for a minimum of 4 man-days to insure that the work is done in a manner fully approved by the respective equipment manufacturer. The manufacturer's representatives shall specifically supervise the installation of the screen and compactor. If there are difficulties in the start-up or operation of the equipment due to the manufacturer's design or fabrication, additional service shall be provided at no cost to the Owner. Services of the manufacturer's representatives and training shall be provided when the first screen is started, with follow-up visits upon start-up of each subsequent screen.
- C. A certificate from each equipment manufacturer shall be submitted stating that the installation of his/her equipment is satisfactory, that the equipment is ready for operation and that the operating personnel have been suitably instructed in the operation, lubrication and care of each unit.

### **3.03 FIELD TESTS**

- A. All defects or defective equipment revealed by or noted during the tests shall be corrected or replaced promptly at the expense of the Contractor, and if necessary, the tests shall be repeated until results acceptable to the Engineer are obtained. The Contractor shall furnish all labor, equipment, and materials necessary for conducting the tests. A report of the field tests shall be submitted to the Engineer.
- B. After installation of the screening equipment, and after inspection, operation, testing and adjustment have been completed by the manufacturer's representative, each mechanical screen and screenings compactor shall be given a running test in the presence of the Engineer, such tests as necessary to indicate that the screening equipment, motors, and drives generally conform to the operating conditions specified and its ability to operate without vibration or overheating. The screening equipment and motors shall operate at the specified speed and capacities without undue noise or vibration. Any undue noise or vibration in the equipment, which is deemed objectionable by the Engineer, will be sufficient cause for rejection of the units.
- C. A thirty-day operating period of the mechanical screens and screenings equipment will be required before acceptance. If equipment performance does not meet the Specifications, corrective measures shall be taken or the equipment shall be removed and replaced with equipment which satisfies the conditions specified.

- D. Written test procedures shall be submitted to the Engineer for approval 30 days prior to testing.

#### **3.04 TRAINING**

- A. A factory representative shall provide a minimum of eight (8) person-hours of training to the Owner's operations staff concerning the recommended operation and maintenance of the equipment. Training shall be performed after substantial completion of the project with the use of operating equipment.

END OF SECTION



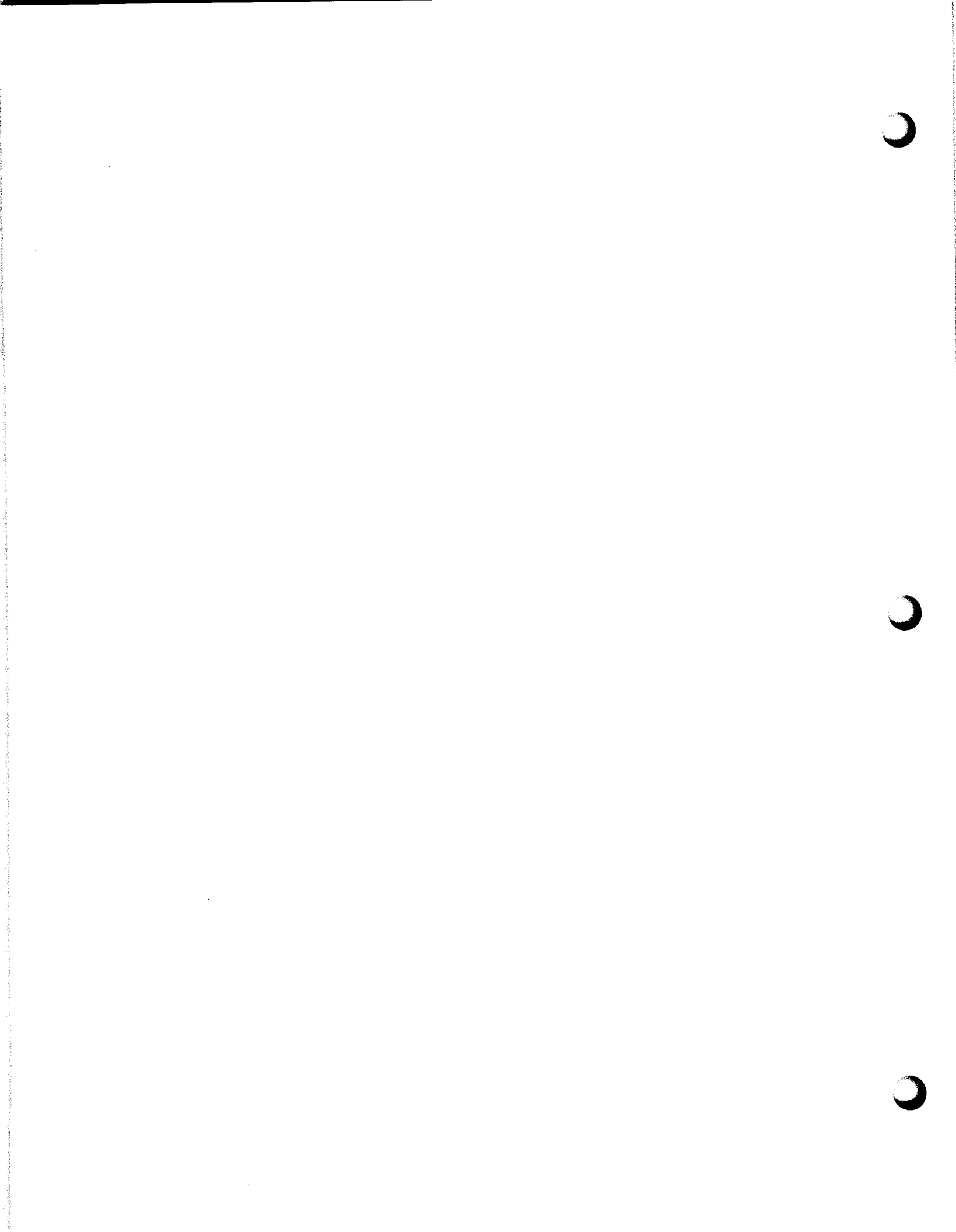

MAYOR JIM GRAY



**LEXINGTON**

TODD SLATIN  
DIRECTOR  
CENTRAL PURCHASING

**ADDENDUM #5**

**Bid Number: #106-2017**

**Date: September 15, 2017**

**Subject: Expansion Area 3 Pump Station (Contract 1) and Force Main  
(Contract 2) Improvements**

**Address inquiries to:  
Brian Marcum  
(859) 258-3320**

**TO ALL PROSPECTIVE SUBMITTERS:**

**Please be advised of the following clarifications to the above referenced bid:**

**The bid opening date has been extended to September 26, 2017 at 2:00 PM EST.**

**Todd Slatin, Director  
Division of Central Purchasing**

**All other terms and conditions of the bid and specifications are unchanged. This letter should be signed, attached to and become a part of your submittal.**

**COMPANY NAME:** \_\_\_\_\_

**ADDRESS:** \_\_\_\_\_

**SIGNATURE OF BIDDER:** \_\_\_\_\_





MAYOR JIM GRAY



**LEXINGTON**

TODD SLATIN  
DIRECTOR  
CENTRAL PURCHASING

**ADDENDUM #6**

Bid Number: #106-2017

Date: September 18, 2017

Subject: Expansion Area 3 Pump Station (Contract 1) and Force Main  
(Contract 2) Improvements

Address inquiries to:  
Brian Marcum  
(859) 258-3320

**TO ALL PROSPECTIVE SUBMITTERS:**

**Please be advised of the following clarifications to the above referenced bid:**

Please see the attached documents for question responses, clarifications and updated wage rates.

A handwritten signature in black ink that reads "Todd Slatin".

Todd Slatin, Director  
Division of Central Purchasing

All other terms and conditions of the bid and specifications are unchanged. This letter should be signed, attached to and become a part of your submittal.

COMPANY NAME: \_\_\_\_\_

ADDRESS: \_\_\_\_\_

SIGNATURE OF BIDDER: \_\_\_\_\_



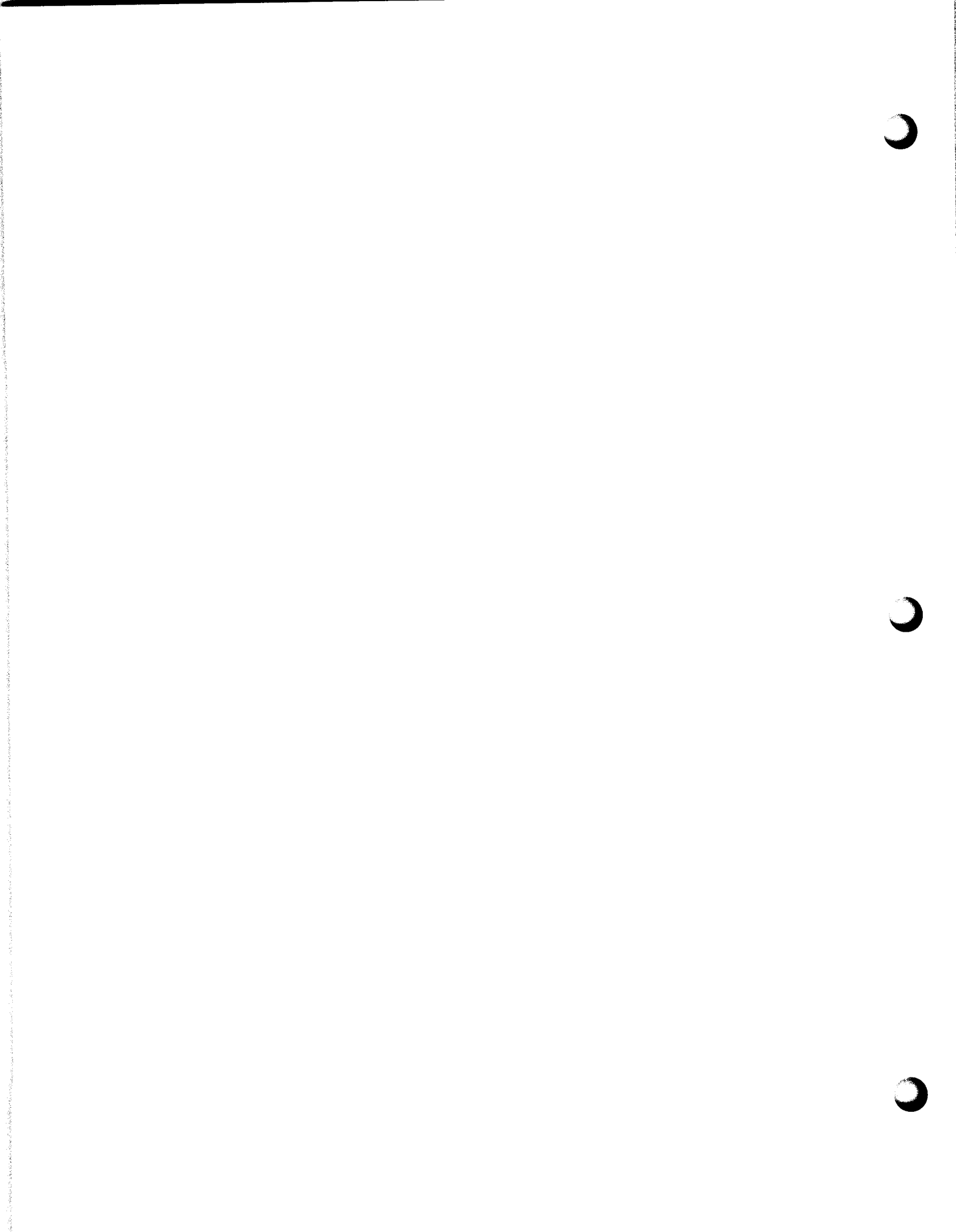

**ADDENDUM #6**Bid Number: #106-2017

Date: September 18, 2017

Subject: Expansion Area 3 Pump Station (Contract No. 1)  
and Force Main (Contract No. 2) ImprovementsAddress inquiries to:  
Brian Marcum  
[brianm@lexingtonky.gov](mailto:brianm@lexingtonky.gov)  
(859) 258-3325**TO ALL PROSPECTIVE SUBMITTERS:**

Please be advised of the following clarifications to the above referenced Bid:

Addendum#4 did not provide a signature line to acknowledge receipt and acceptance of the addendum by signing Addendum#6 you acknowledge receipt of and acceptance of Addendum#4 as well as Addendum#6.

**1. QUESTIONS**

	<b>Questions</b>	<b>Answers</b>
1.	On Spec 08330, Overhead Coiling Doors, operation is listed as manual and motor operated. Do these doors require motor operation or should they be manual chain hoist?	The Overhead Coiling Doors require both manual and motor operation.
2.	The building elevations on Drwg 01A-02 reference a "cupola (vinyl covered)", however there is no specification for this cupola. Please provide a specification for the vinyl covered cupola in the next addendum.	A Cupola description will be added to Sheet 01A-02.
3.	The building elevations on Drwg 01A-02 reference a "vinyl siding", however there is no specification for this siding. Please provide a specification for the vinyl siding in the next addendum.	A vinyl siding description will be added to Sheet 01A-02.
4.	Who pays for structural special inspections and tests?	LFUCG will provide and pay for special inspections.
5.	Is there a fee for the LFUCG Land Disturbance Permit and LFUCG Traffic Engineering Traffic Control or Lane Closure Permit?	\$25 for a Land Disturbance Permit. LFUCG DWQ will cover the cost of any permits fees for Traffic Control or Lane Closures.



6.	Who pays for the KYR10 Storm Water Construction permit? If it is the Contractor, who issues this permit and is there a fee associated with obtaining it?	No fee. KDOW issues the permit.
7.	Section 13252, Article 2.04.F, makes reference to Section 15892 (FRP Piping Systems). This section is not included in the project bid documents. Please provide applicable specifications for the odor control duct and related accessories.	Specification Section 15892 will be added.
8.	Please provide applicable specifications for shot rock material intended for uses where indicated in the bid documents.	See Clarifications.
9.	Sheet 00G-005, Pump Station Contract No. 1, Memorandum of Understanding and Agreement, Item 1.6., discusses Norway Spruce trees to be planted along the Poole property line. Are these trees to be included in the Pump Station bid?	Yes. Contract No. 1 is responsible for all MOU requirements on the Poole property.
10.	In Section 08710, Article 3.03, the Finish Schedule includes 3 hardware sets. No information is provided for Interior Double Doors (required for Door D-13 in the Mechanical Room on Sheet 01A-01). Please provide the applicable information.	Specification Section 08710 will be revised to add a hardware set.
11.	We find no specifications for the landscape plantings. Please provide applicable information.	Use information provided on Sheet SS2.0.
12.	I have attached an RFI asking if Fusible PVC would be allowed for the casing pipe on the above project. If you have any questions please let me know.	Fusible PVC is not allowed for the casing pipe.
13.	We have a question concerning the \$50,000 allowance for Control Touch SCADA Integration. Is this \$50,000 allowance to be used to cover all the work depicted on sheets 01Y-01 thru 01Y-06 and specifications Division 17 Instrumentation?	No. The \$50,000 only covers services provided by Control Touch for software and programming. No instrumentation, panels or hardware, etc., are included.
14.	The door and frame scheduled on plan sheet 01-A-04 indicates that Door 12 (D-12) is a double frame door. Plan sheet 01A-01 shows	Single door is correct as shown on Sheet 01A-01.



	this door as a single door. Please indicate with plan sheet is correct.	
15.	The door and frame scheduled on plan sheet 01-A-04 indicates that Door 13 (D-13) is a single frame door. Plan sheet 01A-01 shows this door as a double door. Please indicate which plan sheet is correct.	Double door is correct as shown on Sheet 01A-01.
16.	Please provide a detail for the Detention Basin Outlet Structure trash rack.	Bid as shown.
17.	How many fire extinguishers are required? The specifications do not state a quantity and we do not see fire extinguishers indicated on the plans.	One is required.
18.	Is the tower referenced in note 12 on plan sheet 01Y-05 existing? If it is existing, please provide tower height and location in relationship to the Pump Station. If it is not an existing tower, please provide a detail of the tower and base, specifications, and location in relationship to the Pump Station.	No. It is new and shall be provided in Contract No.1. Specification Section 17312 will be revised.
19.	What specific items does the \$50,000 Control Touch System Programming Services allowance include?	Software and programming.
20.	Does the allowance include software? If so, what software?	See services included in allowance as indicated in Specification Section 17311.
21.	Does the allowance include programming? If so, what programming?	See services included in allowance as indicated in Specification Section 17311.
22.	The bid documents state that there is a 10% MWDBE goal and a 3% Veteran Owned Business goal giving a total goal of 13%. Can this goal be met by all MWDBE or Veteran Owned, or do the goals need to be met independently?	The goals are independent of each other.
23.	Please confirm the extent of the Contract No. 1 work represented on Drawings SS1.0 and SS2.0 is that of the 10" Sanitary Sewer (Bid Item B2), 4-foot Diameter Manholes (Bid Item B3), 4-foot Diameter Drop	All work, except one area, indicated on Sheets SS1.0 and SS2.0 is required to be completed by Contract No. 1. This includes clearing if needed, berm, landscaping, and all required erosion control requirements in the 75' parallel





	Manhole (Bid Item B4), and Gravity Sewer Site Restoration: Method B (Bid Item B5) and that no clearing, berm, or landscaping work is included under Contract No. 1.	property, adjacent to the pump station property. All work in the force main & access easement area (40') along the north side of property shall be the responsibility of Contract No. 2.
24.	Water Line and Service Connection Note 4 on Drawing 01C-09 stipulates "Contractor to provide water meter service fee". Please provide information on how much this fee is and to whom it get paid.	The water meter service fee is included in Allowance C6. See Specification Section 00890 Permits for KAW requirements.

## 2. CLARIFICATIONS

- A. Blasting is allowed on this project except for pipe installation on the University of Kentucky Agriculture Farm per the MOU listed on Sheet 00G-05, and on LFUCG property South of I-75/I-64. If blasting is performed on the Hospice or Pump Station Site then all blasting requirements shall be followed per Section 02225 Excavating, Backfilling, and Compacting for Sewers including pre-blast surveys, and Project Specific Notes.
- B. Shot rock that is reused per Sheet 01S-01 shall meet KY No. 57 gradation or another gradation approved by the Engineer.
- C. Door Number Labels as shown on Sheet 01A-04 shall be reversed for Doors D-12 and D-13.

## 3. DRAWINGS

- A. Sheet 01A-02, Building Elevations has been revised to include descriptions for a Cupola (vinyl covered) and Vinyl Siding. See Attached.
- B. Sheet 01E-02, One-Line Diagram and Conduit Schedule, revise the "One-Line Diagram" to include a 48" x 48" x 12" NEMA 4X CT Cabinet for secondary service metering. The installation of the cabinet shall be coordinated with Kentucky Utilities. See attached.
- C. Sheet 01E-02, One-Line Diagram and Conduit Schedule, revise the "One-Line Diagram" to include local disconnect switches for Pumps 1, 2, 3 and 4. See attached.
- D. Sheet 01E-02, One-Line Diagram and Conduit Schedule, for the "One-Line Diagram" delete tag note "Pedestal Mounted Enclosure. Typical See Detail Sheet 01E-10" and replace with "Pedestal Mounted Enclosure. Typical See Detail Sheet 01E-08". See attached.
- E. Sheet 01E-02, One-Line Diagram and Conduit Schedule, for the "One-Line Diagram" delete "Grinder Sump Pump" and replace with "Sump Pump SP-251". See attached.



- F. Sheet 01E-02, One-Line Diagram and Conduit Schedule, for the "One-Line Diagram" add a second 3HP sump pump with a 15 amp breaker and FVNR NEMA Size 1. Pump to be labeled "Sump Pump SP-252". See attached.
- G. Sheet 01E-02, One-Line Diagram and Conduit Schedule, for the "MCC-EA3 Elevation" add a second sump pump. Label one pump "Sump Pump SP-251" and the other "Sump Pump SP-252". See attached.
- H. Sheet 01E-04, Control Diagrams, for the "Sump Pump Control Schematic" add "Typical for Pumps SP-251, SP-252". See attached.
- I. Sheet 01E-06, Pump Station Intermediate and Lower Plan Lighting, for the "Light Fixture Schedule", add light fixture LF10 – Emergency battery pack LED light fixture with dual heads, wall mounted. Fixture to be equal to Holophane DM72-N-5—T-NG-2-T. See attached.
- J. Sheet 01E-07, Pump Station Upper Floor Plan Lighting, for the Loadout Area, change light fixtures LF2 to LF8. See attached.
- K. Sheet 01E-07, Pump Station Upper Floor Plan Lighting, for the Electrical Room, change light fixtures LF2A to LF2. See attached.
- L. Sheet 01E-08, Pump Station Intermediate and Lower Plan Power", add a second 3HP, wet well sump pump. Label one pump "Sump Pump SP-251" and the other "Sump Pump SP-252".
- M. Sheet 01E-09, Pump Station Upper Floor Plan Power, add a CT cabinet on the exterior west wall of the building outside the electrical room. For the CT cabinet, add tag note 23, "48" x 48" x 12" NEMA 4X CT Cabinet. Coordinate installation with KUCO." See attached.
- N. Sheet 01E-09, Pump Station Upper Floor Plan Power, for the sump pump pedestal mounted enclosure (tag note 21) delete conduits "[C3], [A6]" and replace with "[C6], [A12]". See attached.
- O. Sheet 01E-09, Pump Station Upper Floor Plan Power, all horn/strobe alarm stations labeled WAH should be changed to XAH. See attached.
- P. Sheet 01E-09, Pump Station Upper Floor Plan Power, relocate horn/strobe alarm station XAH-212 to Screen Room entrance from the Loadout area. See attached.
- Q. Sheet 01E-09, Pump Station Upper Floor Plan Power, add Wet Well and Valve Vault entrance alarm stations located on exterior west wall of the pump station. Label stations "XAH-215" and XAH-216". Add Loadout Area entrance alarm station. Label station "XAH-217. Provide conduit [A3] to LCP-200 for each station. See attached.
- R. Sheet 01E-09, Pump Station Upper Floor Plan Power, for the Screen Room gas sensors, delete conduit [A2] and replace with [S1]. Delete conduit [A6] and replace with [S3]. See attached.



- S. Sheet 01E-09, Pump Station Upper Floor Plan Power, for the Odor Control Room add gas sensors AS-360A, 360B and 360C each with conduit [S1] to AIT-201. Add horn/strobe station at the door entrance to the room. Horn/strobe to be labeled XAH-361 with conduit [A3] to LCP-200. See attached.
- T. Sheet 01E-09, Pump Station Upper Floor Plan Power, for tag note 3, change sheet reference "01E-10" to "01E-08". See attached.
- U. Sheet 01E-09, Pump Station Upper Floor Plan Power, for tag note 16, change sheet reference "01Y-05" to "03Y-04". See attached.
- V. Sheet 01Y-02, Screen Room and Wetwell P&ID, all horn/strobe alarm stations labeled WAH should be changed to XAH. See attached.
- W. Sheet 01Y-02, Screen Room and Wetwell P&ID, devices LSH-101, LSH-111, LE-102 and LE-112 tagged with a single asterisk should be changed to a double asterisk. See attached.
- X. Sheet 01Y-02, Screen Room and Wetwell P&ID, for panel LCP-200, add inputs from XAH-215, XAH-216 and XAH-361. See attached.
- Y. Sheet 01Y-02, Screen Room and Wetwell P&ID, for AIT-201, add sensor inputs from the Odor Control Room sensors AS-360A, AS-360B and AS-360C. See attached.
- Z. Sheet 01Y-02, Screen Room and Wetwell P&ID, for Slide Gate SG-102, the OIT and SCADA I/O labeled "211" should be changed to "102". See attached.
- AA. Sheet 01Y-02, Screen Room and Wetwell P&ID, for the Wet Well high level alarms, the OIT and SCADA labeled "103" should be changed to "203". See attached.
- BB. Sheet 01Y-02, Screen Room and Wetwell P&ID, for the Wet Well high level alarms, the OIT and SCADA labeled "104" should be changed to "204". See attached.
- CC. Sheet 01Y-02, Screen Room and Wetwell P&ID, for the Valve Vault high level, the OIT and SCADA I/O labeled "LSH" should be changed to "LAH". See attached.
- DD. Sheet 01Y-03, Odor Control and Chemical Feed P&ID, for the Odor Control Room, add gas sensors AS-360A, AS-360B and AS-360C; AS-201M, AS-201N and AS-201O. Add horn/strobe alarm stations XAH-361 and XAH-217. See attached.
- EE. Sheet 01Y-03, Odor Control and Chemical Feed P&ID, add Sump Pump SP-252 and the following sheet note:
- FF. "1. Instrumentation shown for Sump Pump SP-251 is typical for Sump Pump SP-252." See attached.
- GG. Sheet 01Y-03, Odor Control and Chemical Feed P&ID, the ATS I/O for the OIT and SCADA labeled "ZI-402" should be changed to "ZI-402A" and "ZI-402B". See attached.
- HH. Sheet 01Y-04, Control Diagram, make the following changes:
  - 1. Add input alarms for Wet Well gas detection, Valve Vault gas detection, Loadout Area and Odor Control Room gas detection. Control and timing relays to be added for each alarm.



2. Provide a common gas alarm from the panel to the RTU.
3. Panel to include controls for horn/strobe stations XAH-215, XAH-216, XAH-217 and XAH-361. The controls shall initiate a horn and strobe light and have the ability to silence the horn.
4. Add a manual reset button for the smoke detectors. See attached.

**4. SPECIFICATIONS**

- A. Section 00820, Wage Determination Schedule, 1.02 A. shall be deleted in its entirety and replaced with General Decision Number: KY170161 08/11/2017 KY161. See attached.
- B. Section 02505, Water Piping shall be revised by adding Article 2.03 Polyvinyl Chloride (PVC) Plastic Water Pipe as follows:
  - “2.03 POLYVINYL CHLORIDE (PVC) PLASTIC WATER PIPE
  - A. AWWA C900 (Outside Diameter compatible with Cast Iron O.D.)
    1. 4 inch through 24-inch PVC plastic pipe shall conform to ANSI/AWWA C900. Pipe shall be pressure Class 165, DR 25. PVC pipe shall have a minimum laying length of 16 feet, with bell end and elastomeric gasket, and with plain end for cast-iron or ductile-iron fittings. Elastomeric gasket shall conform with the requirements of ASTM F-477. The seal of the National Sanitation Foundation Testing Laboratory must appear on each pipe.
    2. Joints for polyvinyl chloride (PVC) mains shall be integral bell and spigot type joints with o-ring gaskets. The cleaning and assembling of the pipe joints shall be in accordance with manufacturer’s recommendations.
    3. If pipe restraint devices are needed, the Contractor shall provide a system compatible with PVC pipe.
    4. All fittings shall be ductile iron per Article 2.01.”
- C. Section 08710, Finish Hardware, Part 3 Execution, Subpart 3.03 Hardware Schedule Shall be revised by adding Set No. 4 – Double Doors Opening Inside  
“3 pr. BB1191 Hinges 4 ½” x 4 ½”



- 1 ea. Lockset 93K-20N15CS3626
  - 1 ea. Closer 4114H-CUSH
  - 2 ea. 407 Wall Stop
  - 2 ea. Door Bottom & Drip DB593A
  - 1 ea. Safety Hasps Hager 1915x4-1/2
  - 1 ea. Threshold S205A"
- D. Section 09250, Gypsum Board is attached.
- E. Section 09660, Vinyl Composition Tile Flooring and Resilient Base is attached.
- F. Section 11133, Submersible Sump Pumps, Part 1 General, Subpart 1.02 A. Sump Pump Schedule shall be revised to provide 2 Duplex pumps in the Wet Well.
- F. Section 11420, Mechanical Screens and Screenings Compactors, Part 2 Products 2.01 A. 4. Shall be revised by removing the acceptance of a one piece Screen Frame. Only flanged subassemblies for the Screen Frame are allowed as indicated in 11420 2.01 A.4.a.
- G. Section 11420, Mechanical Screens and Screenings Compactors, Part 1 General 1.03 A. Maximum Upstream Water Surface Elevation (WSEL) shall be revised to 899.85.
- H. Section 11420, Mechanical Screens and Screenings Compactors, Part 1 General 1.03 A. Discharge Elevation Above Upper Operating Floor, Minimum shall be revised to Minimum 5' or as required by the manufacturer.
- I. Section 11420, Mechanical Screens and Screenings Compactors, Part 1 General 1.04 Manufacturer A. The last sentence shall be deleted and replaced as follows:
- "The mechanical screens and screenings compactors shall be manufactured by Headworks, Inc. or Huber Technology, Inc. or approved equal. The Headworks, Inc. Model shall be Bar Screen MS1."
- J. Section 11420, Mechanical Screens and Screenings Compactors, Part 2 Products 2.01 A.1 shall be revised to provide side frames wall thickness of 0.375" minimum, bottom thickness of 0.3125" minimum, and U-profile support beams for frame of 0.25" thickness minimum.
- K. Section 11420, Mechanical Screens and Screenings Compactors, Part 2 Products 2.01 C.4 shall be deleted and replaced with the following:



"4. Upper Bearings shall be (5.) below. (6.) shall not be used."

- M. Section 11420, Mechanical Screens and Screenings Compactors, Part 2 Products 2.01 E. shall be revised to provide a discharge chute of a thickness of 0.1875 minimum.
- N. Section 15892, Fiberglass Reinforced Plastic Duct is attached.
- O. Section 16050, Basic Electrical Materials and Methods, page 16050-11, Article 1.28 HAZARDOUS AREA CLASSIFICATIONS, delete the area classification "Corrosive, Unclassified" for the Load Out Area and replace with "Class I, Division 1, Group D".
- P. Section 16120, Conductors and Cables, page 16120-2, Article 2.02.B., delete "VFD Cable" and replace with "VFD Cable (Four Wet Weather Pumps Only):"
- Q. Section 16446, Variable Frequency Drives, page 16446-6, Article 2.04, add the following paragraphs:
  - X. The VFD shall be supplied with line side reactors. Reactors to have 5.0 percent nominal impedance; rated for 150 percent overload for 1 minute; insulation temperature rating of 180 degree C; and copper windings.
  - Y. Provide output dv/dt filters where indicated on the Drawings. Filters shall be installed inside the VFD enclosure on the inverter output. Output filters shall consist of a minimum 1.5 percent impedance reactor, in conjunction with a resistor and capacitor network, to form a damped low-pass filter. Use of output reactors alone is not acceptable. Output filters shall be manufa. by TCI or equal.
- R. Section 17311, PLC Hardware and Software, Part 3 Execution shall be revised to include the following:

**" 3.03 SOFTWARE/PROGRAMMING**

Services included in the \$50,000 allowance will be to supply programming necessary for SCADA and should not be considered to be a full I&C proposal. All controls engineering, PLC/ HMI programming, and hardware necessary for the RTU panels will not be included. Included is graphics, database, and alarming for the SCADA system which will present the data to the operator via a PID style graphics screen as well as a text based screen intended to match the pump station screens, and provide trending and historical archiving of data as requested. This effort includes alarming and reports integrated into the SCADA system. Also included is O&M manual and operator training.

Not included is SCADA hardware or software licenses, installation labor and materials, PLC/HMI programming, and all hardware and field Devices."



- S. Section 17312, Radio Telemetry System, Part 1 General shall be revised in include the following:

“B. Contractor shall be responsible to conduct a path study prior to submittals to determine the required antenna height. Results of the path study shall be included with the equipment submittal. For bidding purposes and based on preliminary review, it is anticipated that the tower will be not taller than 30 ft. The tower shall be a self-supporting galvanized steel tower with 316 stainless steel mounting hardware. A concrete foundation shall be adequate for the tower with lightning protection direct connected to ground. The tower shall be in accordance with TIA/EIA/ANSI 222-G.”

- T. Section 17430, Boxes, Panels, and Control Centers, page 17430-1: Article 2.01 FABRICATION, add the following paragraph A.1.b.:

“b. LCP-200 Control Panel. For details, see Sheet 01Y-04.”

- U. Section 17480, Instrument Lists and Reports, page 17480-4: Article 1.04 INSTRUMENT SCHEDULE, add the following instruments:

- Float Switch Low Level Cutoff, LS-252, for Wet Well #2 Sump Pump.
- Gas Sensors, AS-360A, B, C, for Odor Control Room Gas Sensors.
- Pressure Gauge, PSI-211, for Pump Discharge Pressure in the Valve Vault.

- V. Section 17480, Instrument Lists and Reports, page 17480-4: Add the following Article:

1.05 INPUT/OUTPUT LIST:

TAG	DESCRIPTION	TYPE	MODULE	CHANNEL
SI-210	PUMP NO. 1, P-210, SPEED FEEDBACK	AI	1	0
SI-220	PUMP NO. 2, P-220, SPEED FEEDBACK	AI	1	1
SI-230	PUMP NO. 3, P-230, SPEED FEEDBACK	AI	1	2
SI-240	PUMP NO. 4, P-240, SPEED FEEDBACK	AI	1	3
FIR-270	EFFLUENT FLOW, FIT-270	AI	2	0
LIR-252	WET WELL NO. 1 LEVEL	AI	2	1
LIR-262	WET WELL NO. 2 LEVEL	AI	2	2



		AI	2	3
	SPARE	AI	2	3
LI-310	BIOXIDE STORAGE TANK NO. 1, T-310, LEVEL	AI	3	0
LI-320	BIOXIDE STORAGE TANK NO. 2, T-320, LEVEL	AI	3	1
	SPARE	AI	3	2
	SPARE	AI	3	3
SC-210	PUMP NO. 1, P-210, SPEED CONTROL	AO	4	0
SC-220	PUMP NO. 2, P-220, SPEED CONTROL	AO	4	1
SC-230	PUMP NO. 3, P-230, SPEED CONTROL	AO	4	2
SC-240	PUMP NO. 4, P-240, SPEED CONTROL	AO	4	3
	SPARE	AO	5	0
	SPARE	AO	5	1
	SPARE	AO	5	2
	SPARE	AO	5	3
YID-110	MECHANICAL SCREEN NO. 1 RUN STATUS	DI	6	0
XA-110	MECHANICAL SCREEN NO. 1 OVERLOAD	DI	6	1
YID-111	COMPACTOR NO. 1 RUN STATUS	DI	6	2
XA-111	COMPACTOR NO. 1 OVERLOAD	DI	6	3
YID-120	MECHANICAL SCREEN NO. 2 RUN STATUS	DI	6	4
XA-120	MECHANICAL SCREEN NO. 2 OVERLOAD	DI	6	5
YID-121	COMPACTOR NO. 2 RUN STATUS	DI	6	6
XA-121	COMPACTOR NO. 2 OVERLOAD	DI	6	7
YR-101	SLIDE GATE SG-101 IN REMOTE	DI	6	8
XA-101	SLIDE GATE SG-101 ALARM	DI	6	9
ZSO-101	SLIDE GATE SG-101 OPEN	DI	6	10
ZSC-101	SLIDE GATE SG-101 CLOSED	DI	6	11
YR-102	SLIDE GATE SG-102 IN REMOTE	DI	6	12
XA-102	SLIDE GATE SG-102 ALARM	DI	6	13
ZSO-102	SLIDE GATE SG-102 OPEN	DI	6	14
ZSC-102	SLIDE GATE SG-102 CLOSED	DI	6	15
YR-103	SLIDE GATE SG-103 IN REMOTE	DI	7	0
XA-103	SLIDE GATE SG-103 ALARM	DI	7	1
ZSO-103	SLIDE GATE SG-103 OPEN	DI	7	2
ZSC-103	SLIDE GATE SG-103 CLOSED	DI	7	3
YR-111	SLIDE GATE SG-111 IN REMOTE	DI	7	4
XA-111	SLIDE GATE SG-111 ALARM	DI	7	5
ZSO-111	SLIDE GATE SG-111 OPEN	DI	7	6
ZSC-111	SLIDE GATE SG-111 CLOSED	DI	7	7





YR-112	SLIDE GATE SG-112 IN REMOTE	DI	7	8
XA-112	SLIDE GATE SG-112 ALARM	DI	7	9
ZSO-112	SLIDE GATE SG-112 OPEN	DI	7	10
ZSC-112	SLIDE GATE SG-112 CLOSED	DI	7	11
YR-113	SLIDE GATE SG-113 IN REMOTE	DI	7	12
XA-113	SLIDE GATE SG-113 ALARM	DI	7	13
ZSO-113	SLIDE GATE SG-113 OPEN	DI	7	14
ZSC-113	SLIDE GATE SG-113 CLOSED	DI	7	15
YR-301	SLIDE GATE SG-301 IN REMOTE	DI	8	0
XA-301	SLIDE GATE SG-301 ALARM	DI	8	1
ZSO-301	SLIDE GATE SG-301 OPEN	DI	8	2
ZSC-301	SLIDE GATE SG-301 CLOSED	DI	8	3
SDA-211	SCREEN ROOM SMOKE ALARM	DI	8	4
AAH-201	SCREEN ROOM GAS ALARM	DI	8	5
LAH-203	WET WELL NO. 1 HIGH LEVEL ALARM	DI	8	6
LAH-204	WET WELL NO. 2 HIGH LEVEL ALARM	DI	8	7
YID-210A	PUMP NO. 1, P-210, RUN STATUS	DI	8	8
YID-210B	PUMP NO. 1, P-210, IN HAND	DI	8	9
YID-210C	PUMP NO. 1, P-210, VFD/PLC SELECTOR SWITCH STATUS	DI	8	10
XA-210	PUMP NO. 1, P-210, COMMON ALARM	DI	8	11
YID-220A	PUMP NO. 2, P-220, RUN STATUS	DI	8	12
YID-220B	PUMP NO. 2, P-220, IN HAND	DI	8	13
YID-220C	PUMP NO. 2, P-220, VFD/PLC SELECTOR SWITCH STATUS	DI	8	14
XA-220	PUMP NO. 2, P-220, COMMON ALARM	DI	8	15
YID-230A	PUMP NO. 3, P-230, RUN STATUS	DI	9	0
YID-230B	PUMP NO. 3, P-230, IN HAND	DI	9	1
YID-230C	PUMP NO. 3, P-230, VFD/PLC SELECTOR SWITCH STATUS	DI	9	2
XA-230	PUMP NO. 3, P-230, COMMON ALARM	DI	9	3
YID-240A	PUMP NO. 4, P-240, RUN STATUS	DI	9	4
YID-240B	PUMP NO. 4, P-240, IN HAND	DI	9	5
YID-240C	PUMP NO. 4, P-240, VFD/PLC SELECTOR SWITCH STATUS	DI	9	6
XA-240	PUMP NO. 4, P-240, COMMON ALARM	DI	9	7
LAH-201	VALVE VAULT HIGH LEVEL ALARM	DI	9	8
TAH-121	ELECTRICAL ROOM HIGH TEMPERATURE ALARM	DI	9	9
XA-330	BIOXIDE FEED SYSTEM COMMON ALARM	DI	9	10
XA-340	SHOWER/EYEWASH FLOW ALARM	DI	9	11
YID-350	ODOR CONTROL FAN RUN STATUS	DI	9	12



XA-350	ODOR CONTROL FAN RUN OVERLOAD	DI	9	13
YID-251	WET WELL NO. 1 SUMP PUMP RUN STATUS	DI	9	14
XA-251	WET WELL NO. 1 SUMP PUMP ALARM	DI	9	15
YID-252	WET WELL NO. 2 SUMP PUMP RUN STATUS	DI	10	0
XA-252	WET WELL NO. 2 SUMP PUMP ALARM	DI	10	1
YI-401	GENERATOR IN AUTO	DI	10	2
YA-401	GENERATOR PRE-SHUTDOWN ALARM	DI	10	3
YR-401	GENERATOR RUN STATUS	DI	10	4
XA-401	GENERATOR SHUTDOWN ALARM	DI	10	5
LAL-401	GENERATOR LOW FUEL ALARM	DI	10	6
ZI-402A	ATS IN NORMAL POSITION	DI	10	7
ZI-402B	ATS IN EMERGENCY POSITION	DI	10	8
	SPARE	DI	10	9
	SPARE	DI	10	10
	SPARE	DI	10	11
	SPARE	DI	10	12
	SPARE	DI	10	13
	SPARE	DI	10	14
	SPARE	DI	10	15
	SPARE	DI	11	0
	SPARE	DI	11	1
	SPARE	DI	11	2
	SPARE	DI	11	3
	SPARE	DI	11	4
	SPARE	DI	11	5
	SPARE	DI	11	6
	SPARE	DI	11	7
	SPARE	DI	11	8
	SPARE	DI	11	9
	SPARE	DI	11	10
	SPARE	DI	11	11
	SPARE	DI	11	12
	SPARE	DI	11	13
	SPARE	DI	11	14
	SPARE	DI	11	15
ZCC-101	SLIDE GATE SG-101 CLOSE COMMAND	DO	12	0
ZCO-101	SLIDE GATE SG-101 OPEN COMMAND	DO	12	1



ZCC-102	SLIDE GATE SG-102 CLOSE COMMAND	DO	12	2
ZCO-102	SLIDE GATE SG-102 OPEN COMMAND	DO	12	3
ZCC-103	SLIDE GATE SG-103 CLOSE COMMAND	DO	12	4
ZCO-103	SLIDE GATE SG-103 OPEN COMMAND	DO	12	5
ZCC-111	SLIDE GATE SG-111 CLOSE COMMAND	DO	12	6
ZCO-111	SLIDE GATE SG-111 OPEN COMMAND	DO	12	7
ZCO-112	SLIDE GATE SG-112 CLOSE COMMAND	DO	12	8
ZCO-112	SLIDE GATE SG-112 OPEN COMMAND	DO	12	9
ZCO-113	SLIDE GATE SG-113 CLOSE COMMAND	DO	12	10
ZCO-113	SLIDE GATE SG-113 OPEN COMMAND	DO	12	11
ZCC-301	SLIDE GATE SG-301 CLOSE COMMAND	DO	12	12
ZCO-301	SLIDE GATE SG-301 OPEN COMMAND	DO	12	13
	SPARE	DO	12	14
	SPARE	DO	12	15
HS-210	PUMP NO. 1, P-210, RUN COMMAND	DO	13	0
HS-220	PUMP NO. 2, P-220, RUN COMMAND	DO	13	1
HS-230	PUMP NO. 3, P-230, RUN COMMAND	DO	13	2
HS-240	PUMP NO. 4, P-240, RUN COMMAND	DO	13	3
HS-251	WET WELL NO. 1 SUMP PUMP RUN COMMAND	DO	13	4
HS-252	WET WELL NO. 2 SUMP PUMP RUN COMMAND	DO	13	5
	SPARE	DO	13	6
	SPARE	DO	13	7
	SPARE	DO	13	8
	SPARE	DO	13	9
	SPARE	DO	13	10
	SPARE	DO	13	11
	SPARE	DO	13	12
	SPARE	DO	13	13
	SPARE	DO	13	14
	SPARE	DO	13	15

General Decision Number: KY170161 08/11/2017 KY161

Superseded General Decision Number: KY20160161

State: Kentucky

Construction Type: Heavy

Counties: Bourbon, Clark, Fayette, Jessamine, Scott and Woodford Counties in Kentucky.

HEAVY CONSTRUCTION PROJECTS (including sewer/water construction).

Note: Under Executive Order (EO) 13658, an hourly minimum wage of \$10.20 for calendar year 2017 applies to all contracts subject to the Davis-Bacon Act for which the contract is awarded (and any solicitation was issued) on or after January 1, 2015. If this contract is covered by the EO, the contractor must pay all workers in any classification listed on this wage determination at least \$10.20 (or the applicable wage rate listed on this wage determination, if it is higher) for all hours spent performing on the contract in calendar year 2017. The EO minimum wage rate will be adjusted annually. Additional information on contractor requirements and worker protections under the EO is available at [www.dol.gov/whd/govcontracts](http://www.dol.gov/whd/govcontracts).

Modification Number	Publication Date
0	01/06/2017
1	02/24/2017
2	07/14/2017
3	08/04/2017
4	08/11/2017

ELEC0369-004 09/05/2016

	Rates	Fringes
LINE CONSTRUCTION		
Equipment Operator.....	\$ 32.27	20%+5.46
Groundman.....	\$ 21.29	20%+5.46
Lineman.....	\$ 36.12	20%+5.46

ELEC0369-008 06/01/2016

	Rates	Fringes
ELECTRICIAN.....	\$ 30.56	16.10

ENGI0181-016 07/01/2016

	Rates	Fringes
POWER EQUIPMENT OPERATOR		
GROUP 1.....	\$ 31.05	14.65
OPERATING ENGINEER CLASSIFICATIONS		

GROUP 1 - Crane; Forklift

Operators on cranes with boom 150 feet and over, including jib, shall receive \$0.75 above Group 1. All cranes with piling leads will receive \$0.50 above Group 1 rate regardless of boom length. Combination rate shall mean \$0.50 per hour above the basic hourly rate of pay.

Employees assigned to work below ground level are to be paid 10% above basic wage rate. This does not apply to open cut work.

-----  
 ENGI0181-051 07/01/2016

	Rates	Fringes
POWER EQUIPMENT OPERATOR		
GROUP 1.....	\$ 31.05	14.65
GROUP 2.....	\$ 28.28	14.65
GROUP 4.....	\$ 27.97	14.65

OPERATING ENGINEER CLASSIFICATIONS

GROUP 1 - Drill; Pumpcrete; Roller (Bituminous)

GROUP 2 - Bobcat/Skid Steer/Skid Loader; Concrete Pump; Roller (Rock)

GROUP 4 - Pump; Roller (Earth)

Operators on cranes with booms 150 feet and over (including jib) shall receive \$1.00 above Group 1 rate; 250 feet and over including jib shall receive \$1.50 above Class 1 rate. Combination Rate: All crane operators operating cranes, where the length of the boom in combination with the length of the piling leads equal or exceeds 150 feet, shall receive \$1.00 above the Group 1 rate.

Employees assigned to work below ground level are to be paid 10% above basic wage rate. This does not apply to open cut work.

-----  
 IRON0044-005 06/01/2017

	Rates	Fringes
IRONWORKER (STRUCTURAL AND REINFORCING).....	\$ 27.60	20.10

-----  
 \* IRON0070-011 06/01/2017

	Rates	Fringes
IRONWORKER, ORNAMENTAL.....	\$ 28.30	21.85

-----  
 LABO0189-020 07/01/2015

	Rates	Fringes
LABORER		
Concrete Worker.....	\$ 22.30	12.46
-----		
LABO0265-014 05/01/2015		

	Rates	Fringes
LABORER		
Concrete Saw (Hand Held/Walk Behind).....	\$ 28.89	9.85
Flagger.....	\$ 28.72	9.85
-----		
SUKY2011-038 06/25/2014		

	Rates	Fringes
CARPENTER (Form Work Only).....	\$ 24.80	8.76
LABORER: Common or General.....	\$ 22.17	9.64
LABORER: Concrete Finishing.....	\$ 25.75	8.60
LABORER: Pipelayer.....	\$ 19.66	10.85
OPERATOR:		
Backhoe/Excavator/Trackhoe.....	\$ 22.56	12.10
OPERATOR: Bulldozer.....	\$ 27.90	13.00
OPERATOR: Loader.....	\$ 26.68	13.00
OPERATOR: Mechanic.....	\$ 28.60	11.83
OPERATOR: Oiler.....	\$ 24.34	13.00
OPERATOR: Trencher.....	\$ 26.27	12.37
TRUCK DRIVER: Dump Truck.....	\$ 17.82	3.26
-----		

WELDERS - Receive rate prescribed for craft performing operation to which welding is incidental.

=====

Note: Executive Order (EO) 13706, Establishing Paid Sick Leave for Federal Contractors applies to all contracts subject to the Davis-Bacon Act for which the contract is awarded (and any solicitation was issued) on or after January 1, 2017. If this contract is covered by the EO, the contractor must provide employees with 1 hour of paid sick leave for every 30 hours they work, up to 56 hours of paid sick leave each year. Employees must be permitted to use paid sick leave for their own illness, injury or other health-related needs, including preventive care; to assist a family member (or person who is like family to the employee) who is ill, injured, or has other health-related needs, including preventive care; or for reasons resulting from, or to assist a family member (or person who is

like family to the employee) who is a victim of, domestic violence, sexual assault, or stalking. Additional information on contractor requirements and worker protections under the EO is available at [www.dol.gov/whd/govcontracts](http://www.dol.gov/whd/govcontracts).

Unlisted classifications needed for work not included within the scope of the classifications listed may be added after award only as provided in the labor standards contract clauses (29CFR 5.5 (a) (1) (ii)).

---

The body of each wage determination lists the classification and wage rates that have been found to be prevailing for the cited type(s) of construction in the area covered by the wage determination. The classifications are listed in alphabetical order of "identifiers" that indicate whether the particular rate is a union rate (current union negotiated rate for local), a survey rate (weighted average rate) or a union average rate (weighted union average rate).

#### Union Rate Identifiers

A four letter classification abbreviation identifier enclosed in dotted lines beginning with characters other than "SU" or "UAVG" denotes that the union classification and rate were prevailing for that classification in the survey. Example: PLUM0198-005 07/01/2014. PLUM is an abbreviation identifier of the union which prevailed in the survey for this classification, which in this example would be Plumbers. 0198 indicates the local union number or district council number where applicable, i.e., Plumbers Local 0198. The next number, 005 in the example, is an internal number used in processing the wage determination. 07/01/2014 is the effective date of the most current negotiated rate, which in this example is July 1, 2014.

Union prevailing wage rates are updated to reflect all rate changes in the collective bargaining agreement (CBA) governing this classification and rate.

#### Survey Rate Identifiers

Classifications listed under the "SU" identifier indicate that no one rate prevailed for this classification in the survey and the published rate is derived by computing a weighted average rate based on all the rates reported in the survey for that classification. As this weighted average rate includes all rates reported in the survey, it may include both union and non-union rates. Example: SULA2012-007 5/13/2014. SU indicates the rates are survey rates based on a weighted average calculation of rates and are not majority rates. LA indicates the State of Louisiana. 2012 is the year of survey on which these classifications and rates are based. The next number, 007 in the example, is an internal number used in producing the wage determination. 5/13/2014 indicates the survey completion date for the classifications and rates under that identifier.

Survey wage rates are not updated and remain in effect until a new survey is conducted.

#### Union Average Rate Identifiers

Classification(s) listed under the UAVG identifier indicate that no single majority rate prevailed for those classifications; however, 100% of the data reported for the classifications was union data. EXAMPLE: UAVG-OH-0010 08/29/2014. UAVG indicates that the rate is a weighted union average rate. OH indicates the state. The next number, 0010 in the example, is an internal number used in producing the wage determination. 08/29/2014 indicates the survey completion date for the classifications and rates under that identifier.

A UAVG rate will be updated once a year, usually in January of each year, to reflect a weighted average of the current negotiated/CBA rate of the union locals from which the rate is based.

---

#### WAGE DETERMINATION APPEALS PROCESS

1.) Has there been an initial decision in the matter? This can be:

- \* an existing published wage determination
- \* a survey underlying a wage determination
- \* a Wage and Hour Division letter setting forth a position on a wage determination matter
- \* a conformance (additional classification and rate) ruling

On survey related matters, initial contact, including requests for summaries of surveys, should be with the Wage and Hour Regional Office for the area in which the survey was conducted because those Regional Offices have responsibility for the Davis-Bacon survey program. If the response from this initial contact is not satisfactory, then the process described in 2.) and 3.) should be followed.

With regard to any other matter not yet ripe for the formal process described here, initial contact should be with the Branch of Construction Wage Determinations. Write to:

Branch of Construction Wage Determinations  
Wage and Hour Division  
U.S. Department of Labor  
200 Constitution Avenue, N.W.  
Washington, DC 20210

2.) If the answer to the question in 1.) is yes, then an interested party (those affected by the action) can request review and reconsideration from the Wage and Hour Administrator (See 29 CFR Part 1.8 and 29 CFR Part 7). Write to:

Wage and Hour Administrator  
U.S. Department of Labor



200 Constitution Avenue, N.W.  
Washington, DC 20210

The request should be accompanied by a full statement of the interested party's position and by any information (wage payment data, project description, area practice material, etc.) that the requestor considers relevant to the issue.

3.) If the decision of the Administrator is not favorable, an interested party may appeal directly to the Administrative Review Board (formerly the Wage Appeals Board). Write to:

Administrative Review Board  
U.S. Department of Labor  
200 Constitution Avenue, N.W.  
Washington, DC 20210

4.) All decisions by the Administrative Review Board are final.

=====  
END OF GENERAL DECISION

**SECTION 09250  
GYPSUM BOARD**

**PART 1 - GENERAL**

**1.1 SUMMARY**

- A. Section Includes:
  - 1. Gypsum board.
  - 2. Tile backer board.
- B. Related Specification Sections include but are not necessarily limited to:
  - 1. Division 00 - Procurement and Contracting Requirements.
  - 2. Division 01 - General Requirements.
  - 3. Section 07900 - Joint Sealants

**1.2 QUALITY ASSURANCE**

- A. Referenced Standards:
  - 1. ASTM International (ASTM):
    - a. A653, Standard Specification for Steel Sheet, Zinc-Coated (Galvanized) or Zinc-Iron Alloy-Coated (Galvannealed) by the Hot-Dip Process.
    - b. C475, Standard Specification for Joint Compound and Joint Tape for Finishing Gypsum Board.
    - c. C840, Standard Specification for Application and Finishing of Gypsum Board.
    - d. C1047, Standard Specification for Accessories for Gypsum Wallboard and Gypsum Veneer Base.
    - e. C1396, Standard Specification for Gypsum Board.
    - f. D3273, Standard Test Method for Resistance to Growth of Mold on the Surface of Interior Coatings in an Environmental Chamber.
  - 2. Gypsum Association (GA):
    - a. GA-214, Recommended Levels of Gypsum Board Finish.
  - 3. Underwriters Laboratories, Inc. (UL):
    - a. Building Materials Directory.
    - b. Fire Resistance Directory.

**1.3 DEFINITIONS**

- A. Wet Area:
  - 1. Toilet rooms, showers, laboratories, janitor closets, or similar areas.
  - 2. Areas within 5 FT of emergency showers, eye wash stations, service sinks, or mop sinks.

**1.4 SUBMITTALS**

- A. Shop Drawings:
  - 1. See Specification Section 01300 for requirements for the mechanics and administration of the submittal process.
  - 2. Drawings of unusual conditions.
    - a. Control joint layout.
  - 3. Product technical data including:
    - a. Acknowledgement that products submitted meet requirements of standards referenced.
    - b. Manufacturer's installation instructions.
  - 4. Manufacturer's adhesive, joint treatment compound and tape recommendations.

## **PART 2 - PRODUCTS**

### **2.1 ACCEPTABLE MANUFACTURERS**

- A. Subject to compliance with the Contract Documents, the following manufacturers are acceptable:
  - 1. Gypsum board and accessories:
    - a. American Gypsum.
    - b. Georgia-Pacific Building Products.
    - c. National Gypsum.
    - d. USG Corporation.
  - 2. Gypsum board suspension system:
    - a. Armstrong.
    - b. Chicago Metallic Corp.
    - c. USG.
- B. Submit request for substitution in accordance with Specification Section 01631.

### **2.2 MATERIALS**

- A. General:
  - 1. Provide UL Listed materials in fire-resistant rated construction.
  - 2. Furnish in lengths as long as practicable.
- B. Gypsum Board (GB):
  - 1. ASTM C1396.
  - 2. Thickness: 5/8 IN unless noted otherwise.
  - 3. Edges: Tapered.
  - 4. Fire-rated board: Type X.
  - 5. Water-Resistant Gypsum Board (WRGB):
    - a. Water-resistant core and facers.
      - 1) Smooth face for finishing similar to standard gypsum board.
    - b. Mold-resistant: ASTM D3273.
    - c. USG "Sheetrock Mold Tough".
- C. Abuse Resistant Panels (ARP):
  - 1. ASTM C1278.
  - 2. ASTM E119, Flame Spread: 5.
  - 3. ASTM E84, Smoke Developed: 0.
  - 4. Mold-resistant: ASTM D3273.
  - 5. Thickness: 5/8 IN.
  - 6. Edges: Tapered.
  - 7. USG "Fiberock Aqua-Tough AR."
- D. Adhesive: As recommended by board manufacturer.
- E. Joint Treatment Compound:
  - 1. ASTM C475.
  - 2. Recommended by manufacturer for specified board type and location.
  - 3. Do not use self-adhesive fiber mesh tape.
- F. Joint Tape:
  - 1. ASTM C475.
  - 2. Recommended by manufacturer for specified board type and location.

### **2.3 ACCESSORIES**

- A. Trim:
  - 1. ASTM C1047.
  - 2. Galvanized: ASTM A653 G-60, unless noted otherwise.

3. Corner bead:
    - a. Standard type with perforated flanges.
    - b. ClarkDietrich "#103 Deluxe Corner Bead".
  4. Casing and trim bead:
    - a. ClarkDietrich "#200-A Metal U-Trim.
  5. Control and expansion joints:
    - a. ClarkDietrich "#093 Zinc Control Joint."
- B. Fasteners:
1. Gypsum board:
    - a. Self-drilling Type S, corrosion-resistant bugle head screws.
    - b. Provide stainless steel fasteners in wet areas.
- C. Tie Wire and Suspension Wire:
1. Galvanized, soft annealed 12 GA minimum.
  2. Use soft stainless steel wire of same gage in all wet areas and/or exterior areas.
- D. Gypsum Board Suspension System:
1. Direct hung factory fabricated heavy duty rated, single web system.
  2. Electro-galvanized.
  3. Fire rated system, UL-listed.
  4. Chicago Metallic "Fire Front 650 Drywall Furring System."

## **PART 3 - EXECUTION**

### **3.1 INSTALLATION**

- A. General:
1. Verify that metal stud framing has been installed plumb, true, and in accordance with the Contract Documents.
  2. Install ceiling suspension system in accordance with manufacturer's recommendations.
  3. Install gypsum board in accordance with ASTM C840.
  4. Install board in fire-rated construction in accordance with UL requirements.
    - a. Self-adhesive applied fire rated tape is not acceptable for use on board joints in fire rated walls.
    - b. Tape all joints using conventional fire rated joint tape and joint treatment compound.
  5. Erect all board vertically with edges over supporting members.
    - a. See Specification Section 09 22 16 non-structural metal framing.
  6. Provide fasteners of sufficient length to penetrate framing member or stud not less than 3/8 IN.
  7. In curved wall or ceiling applications use 1/4 IN thick board specifically designed for use in radius construction.
    - a. Apply in multiple layers as required to meet minimum drywall thickness specified.
  8. In areas having gypsum board ceilings and walls, install ceiling first.
  9. Bring boards into contact, but do not force into place.
  10. Fit neatly and carefully.
  11. Stagger edge joints on opposite side of a partition so they occur on different framing members.
  12. Hold board in firm contact with support while fasteners are being driven.
  13. Proceed with attachment from center of board toward ends and edges.
  14. Scribe board prior to cutting.
  15. Where gypsum board abuts concrete, masonry, metal deck, exterior doors and windows, or other dissimilar material; provide 3/8 IN joint between edge of gypsum board and abutting material.
    - a. Provide continuous casing bead trim on edge of board.

- b. Seal joint with sealant and backer rod.
- 16. Use water-resistant gypsum board (WRGB) in wet locations not scheduled to receive tile finish or abuse resistant panels (ARP).  
Provide Abuse Installation:
  - 1. Set fasteners between 3/8 and 1/2 IN from edges and 2 IN in from board corner.
    - a. Space maximum of 12 IN on center at edges and in field of board.
    - b. Where board butts at wall/ceiling juncture, hold fasteners back 6 IN from edges.
    - c. Space fasteners closer if required by UL.
  - 2. Where two layers of gypsum board are required:
    - a. Base layer: Install per single layer system procedures.
    - b. Finish layer: Install per single layer system but stagger joints not less than one (1) support from the base layer.
  - 3. Install fasteners, in gypsum board, so that head rests in a slight dimple without cutting face paper or fracturing core or as recommended by board/panel manufacturer.
  - 4. Install screws, in cement backer board, flush with board surface.
    - a. Do not countersink screws.
- C. Control Joints:
  - 1. Install prefabricated control joints to provide following maximum unjointed lengths or areas:
    - a. Partitions: 30 FT, maximum straight run, and at lock side of jamb from head of each door opening to top of partition.
    - b. Ceilings:
      - 1) 50 FT maximum in one (1) direction,
      - 2) At change of direction or irregular shapes.
      - 3) Ceiling area: 2500 SQFT, maximum.
  - 2. Where control or expansion joints occur in fire or sound rated assemblies, install suitable backing material to maintain required rating.
  - 3. Where a partition or ceiling abuts a structural element or dissimilar wall or ceiling, install corner bead, casing bead or other trim as required.
- D. Board Finishing:
  - 1. Securely attach continuous corner beads to all external corners in accordance with manufacturer's recommendations.
  - 2. Provide the following minimum levels of gypsum board finish in accordance with GA-214.
    - a. Areas exposed to view:
      - 1) Surfaces to receive vinyl wall covering: Level #4.
      - 2) Surfaces to receive painted finish: Level #5.
    - b. Areas not exposed to view:
      - 1) Fire rated partitions: Level #2 unless a higher grade of finish is required by UL.
      - 2) Non-fire rated partitions: Level #2.
    - c. Provide additional coats of joint compound as required to completely conceal joints, fasteners and accessories.
      - 1) Joint photographing will not be acceptable.
  - 3. Sand each coat to remove excess joint compound.
    - a. Avoid roughing paper facing on board.
  - 4. Finish surface shall be smooth and free of tool marks and ridges.
  - 5. Prime gypsum board surfaces in accordance with Specification Section 09 91 10.
    - a. After primer has been applied, inspect surfaces and repair and refinish all areas which show defects.
  - 6. Refer to ASTM C840 for additional finishing requirements.

END OF SECTION



**SECTION 09660**  
**VINYL COMPOSITION TILE FLOORING AND RESILIENT BASE**

**PART 1 - GENERAL**

**1.1 SUMMARY**

- A. Section Includes:
  - 1. Vinyl composition tile (VCT).
  - 2. Resilient base (RB).
- B. Related Specification Sections include but are not necessarily limited to:
  - 1. Division 00 - Procurement and Contracting Requirements.
  - 2. Division 01 - General Requirements.

**1.2 QUALITY ASSURANCE**

- A. Referenced Standards:
  - 1. Americans with Disabilities Act (ADA):
    - a. Accessibility Guidelines for Buildings and Facilities (ADAAG).
  - 2. ASTM International (ASTM):
    - a. E648, Standard Test Method for Critical Radiant Flux of Floor-Covering Systems Using a Radiant Heat Energy Source.
    - b. F710, Standard Practice for Preparing Concrete Floors to Receive Resilient Flooring.
    - c. F1066, Standard Specification for Vinyl Composition Floor Tile.
    - d. F1861, Standard Specification for Resilient Wall Base.
    - e. F2034, Standard Specification for Sheet Linoleum Floor Covering.

**1.3 SUBMITTALS**

- A. Shop Drawings:
  - 1. See Specification Section 01300 for requirements for the mechanics and administration of the submittal process.
  - 2. Product technical data including:
    - a. Acknowledgement that products submitted meet requirements of standards referenced.
    - b. Manufacturer's installation instructions.
    - c. Recommendations on adhesives, primers and leveling and patching compounds.
- B. Samples:
  - 1. Full range of colors and patterns for Engineer's color selection of each component specified.
- C. Contract Closeout Information:
  - 1. Operation and Maintenance Data:
    - a. See Specification Section 01780 for requirements for the mechanics, administration, and the content of Operation and Maintenance Manual submittals.

**PART 2 - PRODUCTS**

**2.1 MANUFACTURERS**

- A. Subject to compliance with the Contract Documents, the following manufacturers are acceptable:
  - 1. Vinyl composition tile (VCT):
    - a. Armstrong.
    - b. Azrock.
    - c. Congoleum.
    - d. Mannington Commercial.
    - e. Tarkett Inc.



2. Resilient base:
  - a. Armstrong.
  - b. Burke Flooring.
  - c. Flexco.
  - d. Johnsonite.
  - e. Roppe.
  - f. VPI.
3. Edging strips, reducers and joiners:
  - a. Burke Flooring.
  - b. Flexco.
  - c. Johnsonite.
  - d. Roppe.

B. Submit request for substitution in accordance with Specification Section 01631.

## 2.2 MANUFACTURED UNITS

- A. Vinyl Composition Tile (VCT):
  1. 12 IN SQ x 1/8 IN.
  2. ASTM F1066, Comp 1, Class 2.
- B. Resilient Base (RB):
  1. Rubber or vinyl, ASTM F1861.
    - a. Group 1, solid through-color.
    - b. Style B, covered.
    - c. 1/8 by 4 IN.
  2. Factory-formed outside corners.
  3. Continuous rolls, minimum 95 FT long.
- C. Leveling compound as recommended by manufacturer compatible with adhesives.
- D. Adhesives and primers as recommended by manufacturer.
- E. Sheet Vinyl Accent Stripes: 1/8 x 1 IN plain color homogeneous vinyl with backing.
- F. Edging Strips, Reducers and Joiners:
  1. Thermoplastic vinyl.
    - a. ASTM E648, Class 1 Fire Rated.

## 2.3 MAINTENANCE MATERIALS

- A. Extra Materials:
  1. Furnish Owner the following extra material:
    - a. One (1) carton of each type and color of [slip-resistant floor tile and] vinyl composition tile.
    - b. Minimum 12 LF of resilient linoleum sheet flooring and enough welding rod to install all 12 LF of material.
    - c. Remaining portion of one (1) partially used roll of resilient base material with a minimum of 10 LF of each height, color and type.
  2. Package and label extra materials to protect material during storage.

## PART 3 - EXECUTION

### 3.1 PREPARATION

- A. Prepare surfaces in accordance with manufacturer's recommendations and ASTM F710.
- B. Acclimate [linoleum and] tile to area in which it is to be installed for minimum 72 HRS at 68 DEGF prior to installation.
  1. Provide manufacturer's recommended relative humidity levels.

- C. Fill cracks, joints (except specified expansion joints), etc., in floors with a water-resistant noncrumbling patching and leveling compound.
  - 1. Trowel level.
  - 2. Verify moisture content in concrete substrate is within acceptable limits per the floor covering manufacturer.
    - a. Conduct one (1) test for every 1000 SQFT of flooring per room or area in accordance with manufacturer's recommendation.
    - b. Provide necessary measures to dry out the substrate in accordance with flooring manufacturer's recommendations and retest until acceptable moisture levels are obtained.
- D. Where tile flooring abuts other finish flooring materials and finished surfaces do not align, install and feather leveling compound for approximately 6 IN so that finished surfaces will align.

### 3.2 INSTALLATION

- A. Install products in accordance with manufacturer's instructions.
- B. Floors to be free of all dust, paint, grease, oils, solvents, curing and hardening compounds, sealers and any other deleterious material which may affect the bonding of the adhesive used to install the floor coverings.
- C. Ensure recommended minimum installation temperatures are maintained before, during and after installation as required by the manufacturer.
- D. General:
  - 1. Apply primer and adhesive as recommended by manufacturer.
  - 2. Maintain minimum temperature of 68 DEGF for a minimum of 72 HRS prior to, during and after installation.
- E. Vinyl Composition Tile:
  - 1. Lay in pattern selected by Engineer.
  - 2. Bond tile to floor, flush, tight, and in true alignment with adjacent tiles and with finished surface.
  - 3. Fit neatly into breaks and recesses, against walls, around pipes, and other obstructions.
  - 4. Install edging strips where tile edge is exposed or where flooring terminates.
  - 5. Lay out tile to avoid less than one-half tile at permanent perimeter walls.
  - 6. Perform any cutting or drilling of tile as required.
  - 7. Install accent strips in all door openings directly under door when in closed position.
  - 8. Roll entire floor.
  - 9. Immediately after application and rolling, remove surplus adhesive.
- F. Resilient Base:
  - 1. Install base after wall material has thoroughly dried out.
  - 2. Provide base at intersections of floor and all vertical surfaces in areas scheduled to receive base, where intersection is exposed to view.
  - 3. Set base straight and true.
  - 4. Fit into breaks and recesses.
  - 5. Provide factory-formed outside corners; miter inside corners.
    - a. Make joints tight.
    - b. Where door frames are inset in opening, provide factory formed outside corner returned to frame; trim flush with face of frame.
  - 6. Install with top level and bottom edge in firm contact with floor.
- G. Edging Strips, Reducers and Joiners:
  - 1. Provide edging, reducers and transitions as necessary for terminating flooring or transitioning to adjacent flooring materials.
    - a. Profiles shall be ADA compliant.

### **3.3 CLEANING**

- A. Clean floors in accordance with manufacturer's recommendations.
- B. Prior to final acceptance, wash, wax and buff floors.
  - 1. After thorough cleaning, apply two (2) coats of wax recommended by flooring manufacturer.
  - 2. After each coat, buff floor.

### **3.4 PROTECTION**

- A. Protect with nonstaining, nonsticking building paper as may be necessary to prevent dirt and damage.
- B. Protect traffic areas with fiberboard or plywood laid over nonstaining, nonsticking building paper.

**END OF SECTION**

**SECTION 15892**  
**FIBERGLASS REINFORCED PLASTIC DUCT**

**PART 1 - GENERAL**

**1.1 SUMMARY**

- A. Section Includes:
1. Fiberglass reinforced plastic (FRP) ductwork and accessories as specified and as shown on the Contract Documents for Odor Control Ductwork.
- B. Related Sections include but are not necessarily limited to:
1. Division 00 - Procurement and Contracting Requirements.
  2. Division 01 - General Requirements.

**1.2 QUALITY ASSURANCE**

- A. Referenced Standards:
1. Air Movement and Control Association (AMCA):
    - a. 500-D, Laboratory Methods of Testing Dampers for Rating.
  2. American National Standards Institute (ANSI).
  3. American Society of Mechanical Engineers (ASME).
  4. ASTM International (ASTM):
    - a. C582, Standard Specification for Contact-Molded Reinforced Thermosetting Plastic (RTP) Laminates for Corrosion-Resistant Equipment.
    - b. D2310, Standard Classification for Machine-Made "Fiberglass" (Glass-Fiber-Reinforced Thermosetting-Resin) Pipe.
    - c. D2563, Standard Practice for Classifying Visual Defects in Glass-Reinforced Plastic Laminate Parts.
    - d. D2996, Standard Specification for Filament-Wound "Fiberglass" (Glass-Fiber-Reinforced Thermosetting-Resin) Pipe.
    - e. D3982, Standard Specification for Contact Molded "Fiberglass" (Glass Fiber Reinforced Thermosetting Resin) Ducts.
    - f. E84, Standard Test Method for Surface Burning Characteristics of Building Materials.
  5. Sheet Metal and Air-Conditioning National Contractors Association (SMACNA):
    - a. Thermoset FRP Duct Construction Manual, 1997.
- B. Manufacturer's FRP Quality Assurance Program:
1. Either in-house program or retained from qualified and approved outside source.
  2. Independent from manufacturing production personnel.
  3. Quality control manager experienced in the FRP industry with at least five (5) years of verifiable experience in fabrication of fiberglass structures.
    - a. QC manager is to be approved by the Engineer based on qualifications submitted by the biotower system supplier before fabrication is started.
  4. All steps of the duct fabrication to be witnessed by the quality control manager
  5. Maintain fabrication logs including:
    - a. Record of each level of quality control inspections
  6. All areas of the facility where duct is manufactured or stored must be available for inspection by Owner's representative during normal working hours. Inspection will be at the Owner's discretion.
- C. Manufacturer's Qualifications: Manufacturer shall have experience in manufacturing FRP duct of similar size and configuration to the duct specified herein. For a manufacturer to be determined acceptable for providing the FRP duct on this project, they must show evidence of a minimum of five installations and five years' experience in the design and manufacturer of FRP duct of similar size and type as specified herein. Verifiable installations with contact numbers are required for at least three (3) similar applications.

- D. Except where shown in the Contract Documents, the manufacturer is responsible for locating flexible connections and expansion joints to accommodate installation and thermal expansion, respectively.
- E. Provide, coordinate, service, and guarantee duct and duct accessories specified in this Specification, from one supplier.

### 1.3 SUBMITTALS

- A. See Specification Section 01300 for requirements for the mechanics and administration of the submittal process.
- B. Shop Drawings and Product Data shall include the following:
  - 1. Technical Data:
    - a. Technical bulletins, technical data sheets from "soft-cover" catalogs with name of the manufacturer and all the manufacturer details for systems and products being provided. Items being provided are to be specifically identified in a summary listing.
    - b. All illustrations, detailed drawings, and instructions necessary for installing, operation, and maintenance repair.
    - c. Drawings for each shop fabricated ductwork assembly, flexible couplings, expansion/contraction joints, dampers, or blast gates.
    - d. Ductwork pressure, vacuum, and temperature ratings.
    - e. Blast gate and damper information including pressure ratings, leakage data and performance data. Include copies of AMCA 500D certified leakage rate test reports for sample dampers of every size.
    - f. Flexible Connections and Expansion Joints: Expansion and contraction characteristics and limits.
    - g. Manufacturer's recommended spare parts list.
    - h. Manufacturer's delivery, storage, handling and installation instructions.
    - i. Acknowledgement that products submitted fully complies with the requirements of referenced standards and specifications.
  - 2. System Design sealed by a [Enter the State] Registered Engineer.
    - a. Duct support location Drawings.
    - b. Duct system flexible connectors, expansion joint, fittings and appurtenances location and detail Drawings.
    - c. Duct interfacing requirements with duct accessories and method of fastening or support.
    - d. Duct support reactions at each support for all applicable loads including dead load, live load, wind load and thermal expansion and contraction loads.
    - e. Fabricator's detailed structural calculations for fiberglass laminate design.
      - 1) Design for pressure, vacuum, expansion, wind, snow loading as well as deflection for support spacing shown on Drawings.
      - 2) Detailed structural calculations for wall thickness, stress and strain support reactions (including expansion/contraction forces) and expected loadings.
  - 3. Scaled installation Drawings for all foul air duct system shown on the Drawings which shall include the following minimum information:
    - a. Dimensioned locations.
    - b. Elevations (centerline).
    - c. Duct and joint description.
    - d. Location of dampers and fittings.
    - e. Location of supports.
    - f. Location of expansion and contraction joints.
    - g. Details of duct supports (frames, stanchions, towers, etc.) including modifications (if any) to details shown on Drawings.
  - 4. Samples of duct materials.
- C. Operation and Maintenance Manuals:
  - 1. Submit for all applicable equipment.
  - 2. See Section 01780.

- D. Warranty Certificate: Submit manufacturer's sample warranty certificate with product data submittal for Engineer's review. Warranty certificate shall reflect the warranty requirements and duration and as specified herein.
- E. Testing:
  - 1. Preliminary source and field quality control testing format to be used as basis for final quality control reporting.
  - 2. Source quality control test reports in accordance with Article 2.4 of this Specification.
  - 3. Field quality control test reports in accordance with Article 3.3 of this Specification.

#### 1.4 SYSTEM DESCRIPTION

- A. Manufacturer and Contractor shall coordinate with the odor control equipment supplier to ensure compatibility of the ductwork with the other components of the odor control system.

### PART 2 - PRODUCTS

#### 2.1 MANUFACTURERS

- A. Subject to compliance with the Contract Documents, the following manufacturers are acceptable:
  - 1. Ductwork and Dampers:
    - a. Augusta Fiberglass.
    - b. Belco Manufacturing Company, Inc.
    - c. Daniel Company.
    - d. Viron International Corp.
  - 2. Flexible Connections and Expansion Joints:
    - a. Mercer Rubber Co.
    - b. Holz Rubber Co., Inc.

#### 2.2 SERVICE CONDITIONS

- A. Outdoors and Indoors.
- B. Temperature: -10 to +110 DEGF.
- C. Design operating conditions:
  - 1. Vacuum service, inches water: [-20].
  - 2. Pressure service, inches water: [20].
- D. Gases conveyed: Odorous air from municipal wastewater process sources.
- E. Relative humidity: 30 to 100 PCT.
- F. Maximum velocity: 3,000 FT per minute.
- G. Hydrogen sulfide exposure: up to [XXX] ppm.

#### 2.3 COMPONENTS

- A. Ductwork:
  - 1. Duct shall consist of a filament-wound, exterior, structural layer and an internal corrosion barrier composed of a resin-rich inner surface followed by a layered-up interior layer.
  - 2. The internal corrosion barrier shall be in compliance with ASTM C582, ASTM D3982, and Thermoset FRP Duct Construction Manual, 1997.
  - 3. Resin:
    - a. Hexion 992FR, Derakane 510B.
    - b. Premium grade and corrosion resistant.
    - c. Shall not contain thixotropic agents or fillers unless specified.
    - d. Shall not contain dyes, pigments or colorants except in the exterior gel coats.
    - e. Include ultraviolet absorbers added to outer layers to improve weather resistance.

- f. May contain up to 3 PCT antimony oxide in order to meet the class I flame spread rating per ASTM E84.
- 4. Inner surface:
  - a. Minimum of 20 mils thick and consist of a "C" glass surfacing veil with approximately 90 PCT resin content by weight.
  - b. Free of cracks and crazing with a smooth finish comparable to that achieved by the rotary contact molding method, with an average of not over two (2) pits/SQ FT, providing the pits are less than 1/8 IN DIA and not over 1/32 IN deep. Pits shall be covered with sufficient resin to avoid exposure of interior layer.
- 5. Interior layer:
  - a. Reinforced by not less than two plies of 1-1/2 OZ/SQ FT chopped strand mat with approximately 75 PCT resin and 25 PCT glass content by weight. Total thickness shall be at least 100 mils.
- 6. Exterior layer:
  - a. The exterior layer or body of the laminate shall be of chemically resistant construction suitable for operating in the service conditions above and providing additional mechanical strength necessary to meet the tensile and flexural requirements.
  - b. For rectangular duct and transitions, the exterior layer shall conform to the requirements of ASTM D3982 unless otherwise specified and consist of alternating layers of chopped-strand mat or equivalent chopper roving and woven roving to form composite construction of approximately 70 PCT resin by weight. A continuous layer shall be achieved by staggering and lipping layers. The exterior surface shall be relatively smooth and coated to ensure no exposed fiber.
  - c. For round duct, the exterior layer shall conform to the requirements of ASTM D2310 Type I, Grade 2, Class E and be in compliance with ASTM C582 and Thermoset FRP Duct Construction Manual, 1997 unless otherwise specified. The exterior layer shall be constructed of continuous roving by filament winding per ASTM D2996 with a single layer of woven roving to be applied after every 3/8 IN of filament winding to allow for exotherming.
  - d. Woven roving: Type E glass, nominal 24 OZ per square yard, four by five weave, with silane type finish.
  - e. Continuous roving used in chopper gun for spray-up: Type E glass.
  - f. Continuous roving used in filament winding: Type E glass, with silane type finish.
  - g. Shop applied resin gel coat of a color selected by the Engineer shall be provided to the exterior of the duct.
- 7. Laminate quality: Meet requirements of the visual acceptance criteria in ASTM D2563, Level II for the interior and Level III for the exterior.
- 8. Wall thickness for rectangular duct shall be calculated using a safety factor of five to one for both vacuum and positive pressure per ASTM D3982. Wall thickness for round duct shall be calculated using a safety factor of five to one for vacuum pressure and 10 to 1 for positive pressure per ASTM D3982. Calculations shall be based on the structural fiberglass reinforced portion of the wall only. Where calculated structural wall thickness is less than the corresponding minimum wall thickness provided below, the minimum wall thickness dictated by the schedule shall be used.

Duct Size	Minimum Wall Thickness (inches)	Maximum Wall Thickness (inches)
For 18 IN & smaller ducts	0.25	0.375
20 to 36 IN ducts	0.375	0.50
40 to 54 IN ducts	0.50	0.625
60 to 72 IN ducts	0.625	0.75

9. Duct shall be supplied in the largest possible fabricated sections, allowing as few field joints as possible while assuring maximum quality control.
  - a. Minimize the use of flanges with butt wrapped joints where required for installation.
  - b. Shop spool duct and fittings as much as possible.
10. Reinforcing shall be factory installed with spacing between reinforcing located to avoid all hangers and support saddles.

B. Flanges:

1. Drill per ASTM D3982 Table 1 for all duct-to-duct connections and drilled to match for all equipment connections.
2. Spot-faced back, flat and parallel with the flange face, of sufficient diameter to accept a SAE metal washer under the bolt head or nut.
3. Provide full-faced, 1/8 IN thick, fabricated from ethylene propylene rubber (EPR) gaskets at each flanged connection.
4. Flat washers shall be provided on all flange back faces.

C. Fasteners:

1. Bolts for flanges: ASTM A193, Type 316 L stainless steel, Grade B8M hex head bolts fabricated in accordance with ANSI B18.2.
2. Nuts: ASTM A194, Type 316 L stainless steel, Grade 8M hex head nuts.
3. Washers: ASME B18.22.1, Type 316 L stainless steel.
4. Interior bolts for dampers: FRP bolts.

D. Joints:

1. All joints shall be of the same resin as and equal or superior in strength to the adjacent duct section, and shall have the same internal dimensions as the adjacent duct.
2. Total width of overlay for butt-wrap joints: 6 IN minimum.
3. Bell and spigot joints shall be sealed with a standard butt joint overlay as per ASTM D3982. The interior opening between the bell and spigot joint shall be sealed with a resin paste so that no glass fibers are exposed and all voids are filled.

E. Fittings:

1. All fittings shall be of the same resin as and equal or superior in strength to the adjacent duct section, and shall have the same internal dimensions as the adjacent duct.
2. Construction: Spray-up/contact molding or mitered/hand lay-up methods.
3. Unless restricted by space constraints, bends shall have a minimum radius of 1.5 times the duct diameter. Under no circumstances shall bends have a radius less than 1.0 times the duct diameter.

F. Flexible Connections and Expansion Joints:

1. Flexible connections shall be provided for connections to draw-offs and equipment including as indicated on the Drawings. Supports shall be provided where necessary to avoid strain on the flexible connections.
2. Flexible connections and expansion joints shall be furnished and installed as determined by the manufacturer and where indicated on the Drawings. Expansion joints shall be used for lateral, torsional, angular and axial movement due to expansion/contraction and vibration or where required to accommodate thermal expansion.
3. Flexible connections and expansion joints shall be constructed of multiple layers of vulcanized polyester tire cord fabric reinforcement, sandwiched between 60 - 70 durometer EPDM elastomer inner liner and exterior cover. Tire cord fabric shall be layered at an optimal bias angle with Resorcinol Formaldehyde latex for superior rubber-to-fabric bonding.
4. Flexible connections and expansion joints shall be of seamless construction, built as one continuous piece with integral molded, hollow arched volutes permitting up to 4 IN of axial contraction and expansion.
5. Type 316 L stainless steel back up retainers and Type 316 L stainless steel nuts, bolts and washers shall be provided.



6. Flexible connections shall be able to withstand the 25 IN water column, positive and negative pressure.
  7. Flexible connections shall be designed to withstand a maximum temperature of 220 DEGF continuous service with 250 DEGF intermittent spikes.
  8. Flexible connections and expansion joints shall be UV resistant.
  9. Flexible connections shall be designed to allow for a minimum of 1 IN of offset movement in any direction.
  10. Flanges shall be provided in accessible locations for removal of flexible connections and expansion joints. Flanges shall be drilled per ASTM D3982 Table 1 for all duct-to-duct connections and drilled to match for all equipment connections.
  11. Manufacturers.
    - a. RM Holtz.
    - b. Mercer.
- G. FRP Butterfly Dampers:
1. Butterfly balancing dampers for odorous air service shall be fiberglass reinforced plastic body, disc, and shaft. All dampers shall be flanged.
  2. Dampers must be suitable for service conditions previously mentioned.
  3. Laminate construction shall conform to ASTM C582. Laminating resins for exposed dampers shall contain compounds for fire retardance. All inner surfaces shall be reinforced with C-glass. All interior layers shall be a minimum of 0.1 IN thick, reinforced with chopped strand mat applied in a minimum of two (2) piles. The structural layer shall be alternating layers of chopped strand mat and woven roving.
  4. The final resin coat color shall be the same as the adjacent ductwork.
  5. Connections to FRP ductwork shall conform to ASTM D3982.
  6. Isolation Dampers are to be bubble tight, no leak. These include dampers to isolate fans and individual scrubber systems.
  7. Construction:
    - a. Round, flange ends matching inside diameter of connecting ductwork.
    - b. Single blade type complete with channel type frame.
    - c. Full circumference blade seal.
    - d. Angle type blade stop.
    - e. Body material: FRP.
    - f. Disc material: FRP.
    - g. Shaft: Type 316 stainless steel.
    - h. Shaft seal: EPDM or Teflon.
    - i. Blade stop: FRP bar or angle.
    - j. Blade seal: EPDM.
    - k. Sleeve bearings: Molded Teflon.
  8. Dampers shall carry the AMCA Certified Ratings Seal for air leakage and shall be tested as specified herein.
    - a. Leakage: [2 CUFTM/SQ FT at 30 IN w.g., maximum].
  9. Manufacturers:
    - a. Daniel Mechanical Company.
    - b. Indusco.
    - c. Belco.
    - d. Augusta Fiberglass.
- H. FRP Butterfly Damper Operators:
1. Manual Operator:
    - a. Operator force not to exceed 40 LBS under any operating condition, including initial breakaway. Gear reduction operator when force exceeds 40 LBS.
    - b. Operator self-locking type or equipped with self-locking device.
    - c. Worm and gear operators 1-piece design worm gears of gear bronze material. Worm hardened alloy steel with thread ground and polished. Traveling nut type operators threaded steel reach rods with internally threaded bronze or ductile iron nut.

- d. For dampers less than 30 IN DIA, provide Type 316 stainless steel shaft, lever operators, and accessories. For dampers 30 IN DIA or larger, provide handwheel and necessary hardware in lieu of lever operator.
- e. Chainwheel operators with tiebacks, extension stem, and other accessories will be required at all FRP dampers with the operator mounted higher than 6 FT.
- f. All dampers must permit operation from normal operation level. The operator shall maintain the damper in a fixed position, preventing accidental movement.
- g. Provide damper position indicator such that position can be identified from a distance of 15 FT.
- h. Provide motorized operators where shown on the drawings.
- 2. Motor Operated Electric Damper Actuator:
  - a. Motor actuators are to be provided and installed as shown in the contract drawings. Operator functionality is to be consistent with P&IDs [with ability to be controlled remotely from plant SCADA].
  - b. Damper actuators are to include remote local control panels.
- 3. Manufacturers:
  - a. Rotork IQT Pro 1000.
- I. Blast Gates:
  - 1. Blast gates shall be furnished at all take-off points for odor control ductwork where shown in contract drawings.
  - 2. Material: FRP and of the same resin used for the ductwork.
  - 3. Blast gates shall be single blade, ultra low leak, corrosion resistant and suitable for operating in the service conditions above.
  - 4. All blast gates shall be equipped with manual type operators.
    - a. Provide a means of locking the gate in place once the odor control system has been balanced.
  - 5. Blast gates shall be designed to be serviced without removal from the system.
- J. Accessories:
  - 1. Extra Tappings:
    - a. Test port tappings shall be positioned as necessary for air balancing. Manufacturer shall ensure tapping points are accessible for measurement.
    - b. Drain tappings shall be positioned as indicated on Drawings. Drains shall be FRP threaded couplings glassed into the bottom of the duct. The fitting shall be trimmed flush with the interior surface of the duct and the duct shall be recoated at the connection.
  - 2. Hangers and Supports:
    - a. System design for supports shall include snow, wind, thermal and seismic loads as specified in the Building Code and as indicated on the Drawings.
    - b. All hangers and supports shall be manufactured from [aluminum] for corrosion resistance, unless shown otherwise on the Drawings.
    - c. Saddles, guides, sleeves, sleeve liners, etc. shall be provided as recommended by the Manufacturer and meeting Design Detail requirements in the Drawings.
    - d. Design the necessary supports to ensure maximum deflection of 1/2 PCT of duct diameter.
    - e. All duct hangers shall be provided per SMACNA recommendations and the requirements of the Manufacturer. Hangers are to be securely fastened to avoid vibration and care shall be taken to install hangers so as to avoid creating conditions of stress in the finished installation.
    - f. Supports shall be designed to accommodate thermal expansion of the FRP ducts for a temperature range of 100 DEGF through the use of sliding surfaces or location of expansion joints.

## 2.4 SOURCE QUALITY CONTROL

- A. Factory inspection: Inspect fabrications for required construction, intended function, and conformance with referenced standards.

- B. Inspection of products is required prior to shipment, unless specifically waived in writing by Engineer.
- C. Notify Engineer one week prior to estimated date of factory inspection.
- D. Engineer has the option to test FRP duct materials and inspect the manufacturing facility at any time to assure compliance with specifications.

### **PART 3 - EXECUTION**

#### **3.1 DESIGN**

- A. Project Engineer's Bidding Drawings contain information on duct support locations which are only estimates. Duct support design shall be the responsibility of the Duct supplier and Contractor. Sealed layout drawings are to be provided for review and approval prior to fabrication and installation.
- B. Final location of supports may be affected by below grade piping or utilities. Contractor shall coordinate.

#### **3.2 INSTALLATION**

- A. Install duct systems as shown on plans in conformance with duct manufacturer's instructions.
  - 1. The manufacturer shall have a qualified employee at the job site to instruct the Contractor's personnel in proper installation procedures for a minimum of three days.
  - 2. Instruction should include review of material safety data sheets as well as storage and handling of materials.
  - 3. Install to the lines and grades shown on the Drawings and approved duct layout submittals.
  - 4. Whenever duct laying is stopped, close open end of the duct with an end board closely fitting the end of the duct to keep foreign material out of the duct.
- B. Field joints:
  - 1. Field assembly joints must be completed in a neat and orderly manner, in compliance with manufactures instructions.
  - 2. Provide material for each field joint in kit form. One kit shall make one joint.
  - 3. Make field joints only when temperature is between 40 and 100 DEGF.
  - 4. Provide craftsmen who are trained and certified by the manufacturer to perform field joints.
  - 5. The Engineer shall inspect the first field joint made for quality purposes. No additional field joints shall be made without approval of the Engineer. The first joint will set the quality standard for all subsequent joints.
- C. After laminate inspection has been completed, touch-up duct with field applied resin gel coat. Match color to factory applied gel coat, using resin supplied from duct manufacturer. Obtain Engineer's approval for uniform quality of field and factory applied gel coats.

#### **3.3 FIELD QUALITY CONTROL**

- A. Testing:
  - 1. Testing shall not start without an approved leak testing procedure from the Duct Supplier. Unless otherwise approved in this procedure the following is required.
  - 2. Prior to testing, pressurize system to 1.0 PSI and survey all joints for audible or visual leaks.
    - a. Repair/seal as necessary to seal all audible leaks.
  - 3. After all audible leaks have been eliminated, test duct system at 0.75 PSI pressure with air for one hour.
  - 4. Pressure drop during test shall be less than 5 PCT.
  - 5. Contractor to repair all leaks and repeat test.
  - 6. Determine leakage by loss of pressure.
  - 7. Plug or cap branch lines as required during testing.
  - 8. All testing shall be at the expense of the Contractor.
- B. Identification:

1. Identify each shop fabricated duct section with a permanent marker on the inside near the ends.
  2. Project Engineer has option to test FRP duct during construction to ensure compliance with specifications.
- C. Engineer has the option to require testing of FRP duct materials and inspect the manufacturing facility at any time to assure compliance with specifications.

**END OF SECTION**

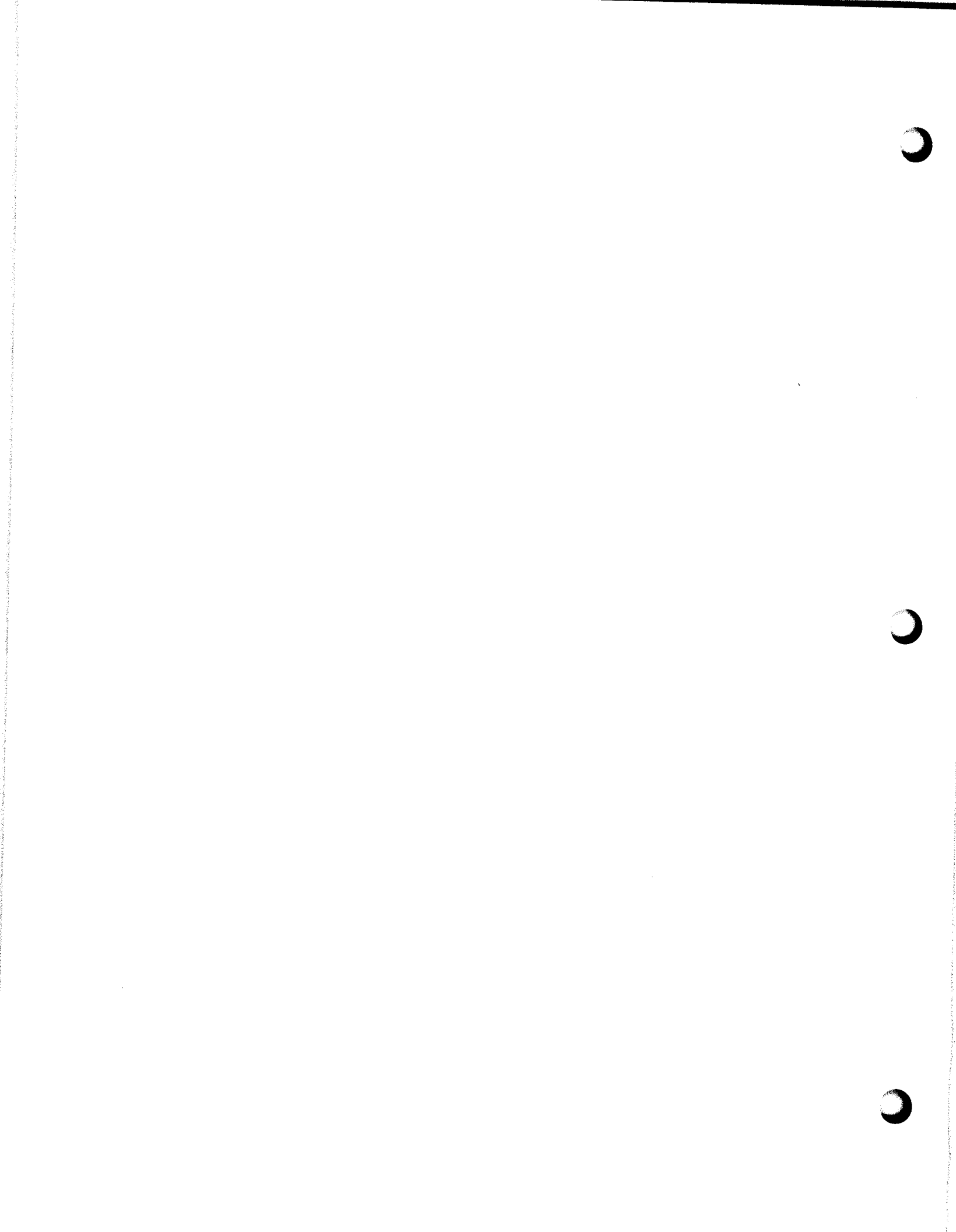



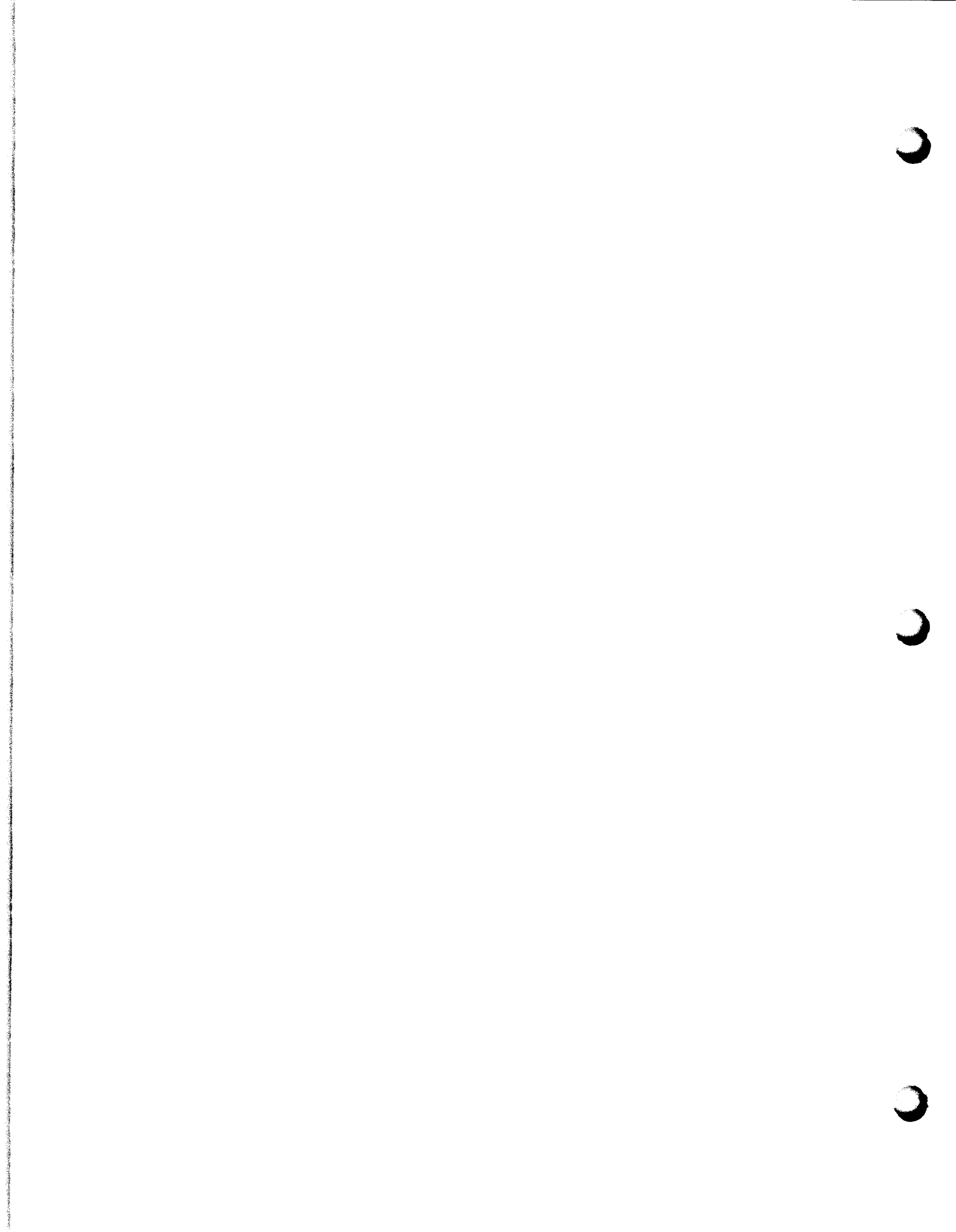

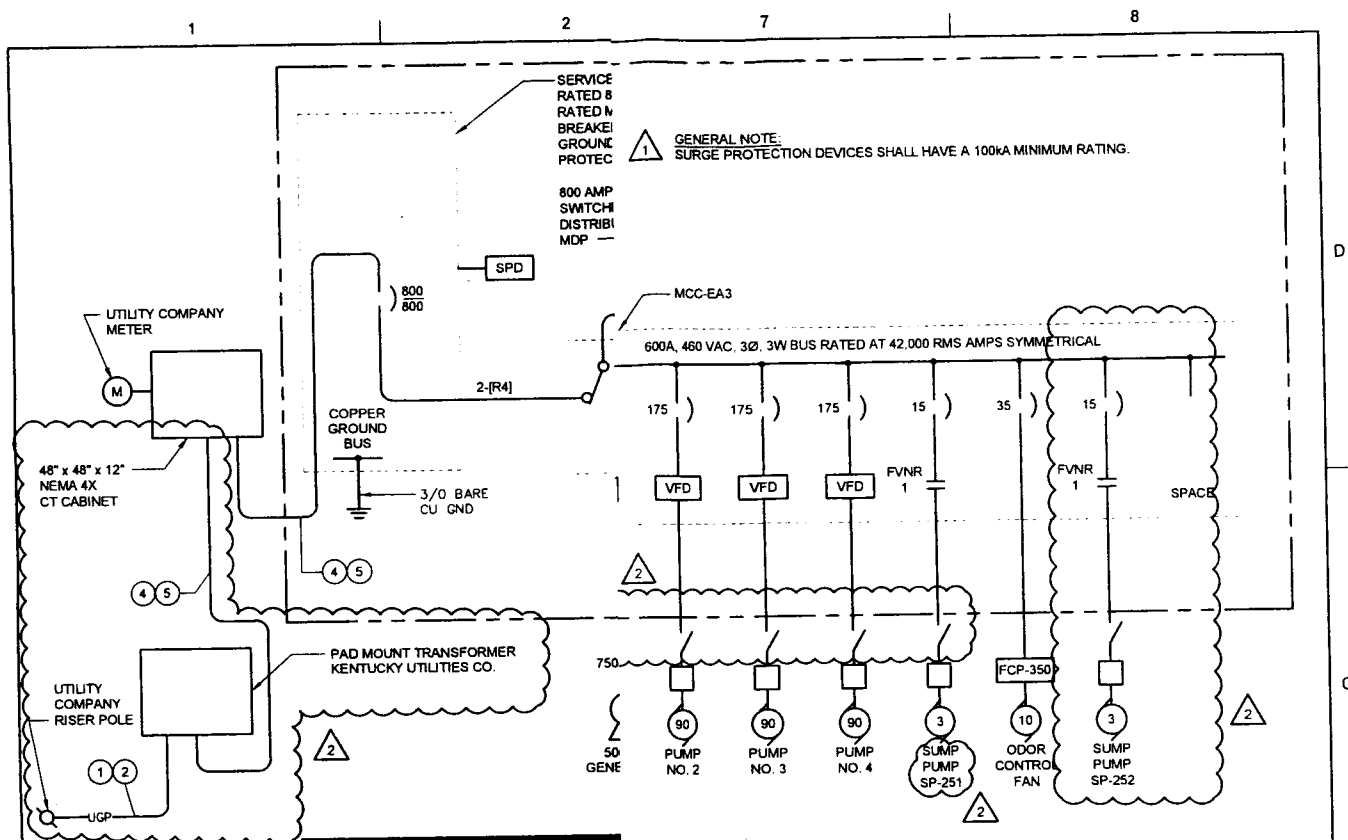

GENERAL NOTE: SURGE PROTECTION DEVICES SHALL HAVE A 100KA MINIMUM RATING.

SERVICE RATED 8 RATED N BREAKER GROUNDED PROTECT

800 AMP SWITCH DISTRIBUTION

CONDUIT SCHEDULE

TAG NO.	FROM	TO	UNIT CALLOUTS
①	UTILITY COMPANY RISER POLE	TRANSFORMER	TRN 3/4" CONDUIT, 2-#14
②	UTILITY COMPANY RISER POLE	TRANSFORMER	TRN 3/4" CONDUIT, 3-#14
③	UTILITY COMPANY RISER POLE	ELECTRICAL ROOM	ELE 3/4" CONDUIT, 4-#14
④	PAD MOUNT TRANSFORMER	ELECTRICAL ROOM	ELE 3/4" CONDUIT, 5-#14
⑤	PAD MOUNT TRANSFORMER	ELECTRICAL ROOM	ELE 3/4" CONDUIT, 7-#14
⑥	AUTOMATIC TRANSFER SWITCH	ELECTRICAL ROOM	ELE 1" CONDUIT, 8-#14
⑦	AUTOMATIC TRANSFER SWITCH	ELECTRICAL ROOM	ELE 1" CONDUIT, 10-#14
⑧	ENTRANCE GATE LIGHT FIXTURE	ELECTRICAL ROOM	ELE 1 1/4" CONDUIT, 14-#14
⑨	FLOW METER VAULT SUMP PUMP RECP., LIGHT	ELECTRICAL ROOM	ELE 1 1/4" CONDUIT, 18-#14
⑩	ELECTRICAL ROOM PANEL LP	ELECTRICAL ROOM	EMERG 3/4" CONDUIT, 3-#12, 1-#12 GROUND
⑪	ELECTRICAL ROOM RTU	ELECTRICAL ROOM	EMERG 3/4" CONDUIT, 4-#12, 1-#12 GROUND
⑫	ELECTRICAL ROOM AUTO. TRANSFER SW.	ELECTRICAL ROOM	EMERG 3/4" CONDUIT, 5-#12, 1-#12 GROUND
⑬	FLOW INDICATOR/TRANSMITTER FIT-202	ELECTRICAL ROOM	FLO 3/4" CONDUIT, 2-#10, 1-#10 GROUND
⑭	GENERATOR MAIN CONTROL PANEL	ELECTRICAL ROOM	GEN ANN 1" CONDUIT, 6-#10, 1-#10 GROUND

NOTE: CONDUITS 3, 4, 5, 6, 13 AND 15 TO BE ENCASED IN RIGID PVC. ALL OTHER CONDUITS TO HAVE SA...



2	9/1
1	9/1
ISSUE	D

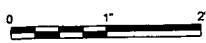

ONE-LINE DIAGRAM AND CONDUIT SCHEDULE

FILENAME: 01E-02.dwg  
SCALE: NONE

SHEET 01E-02





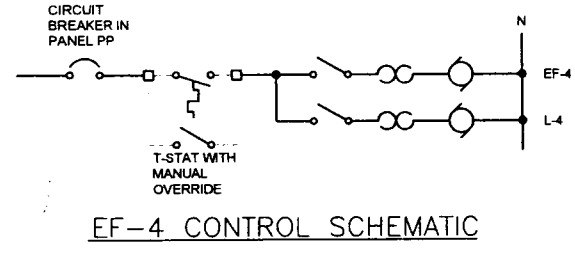
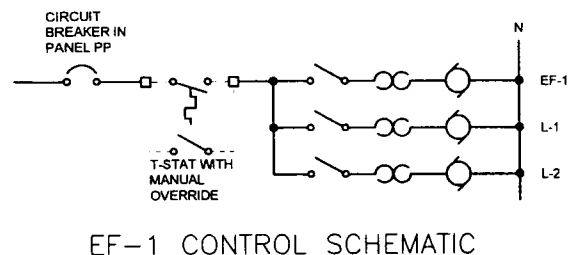
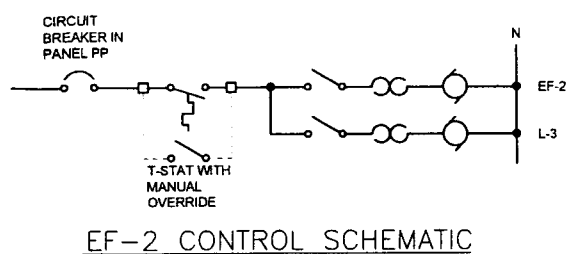
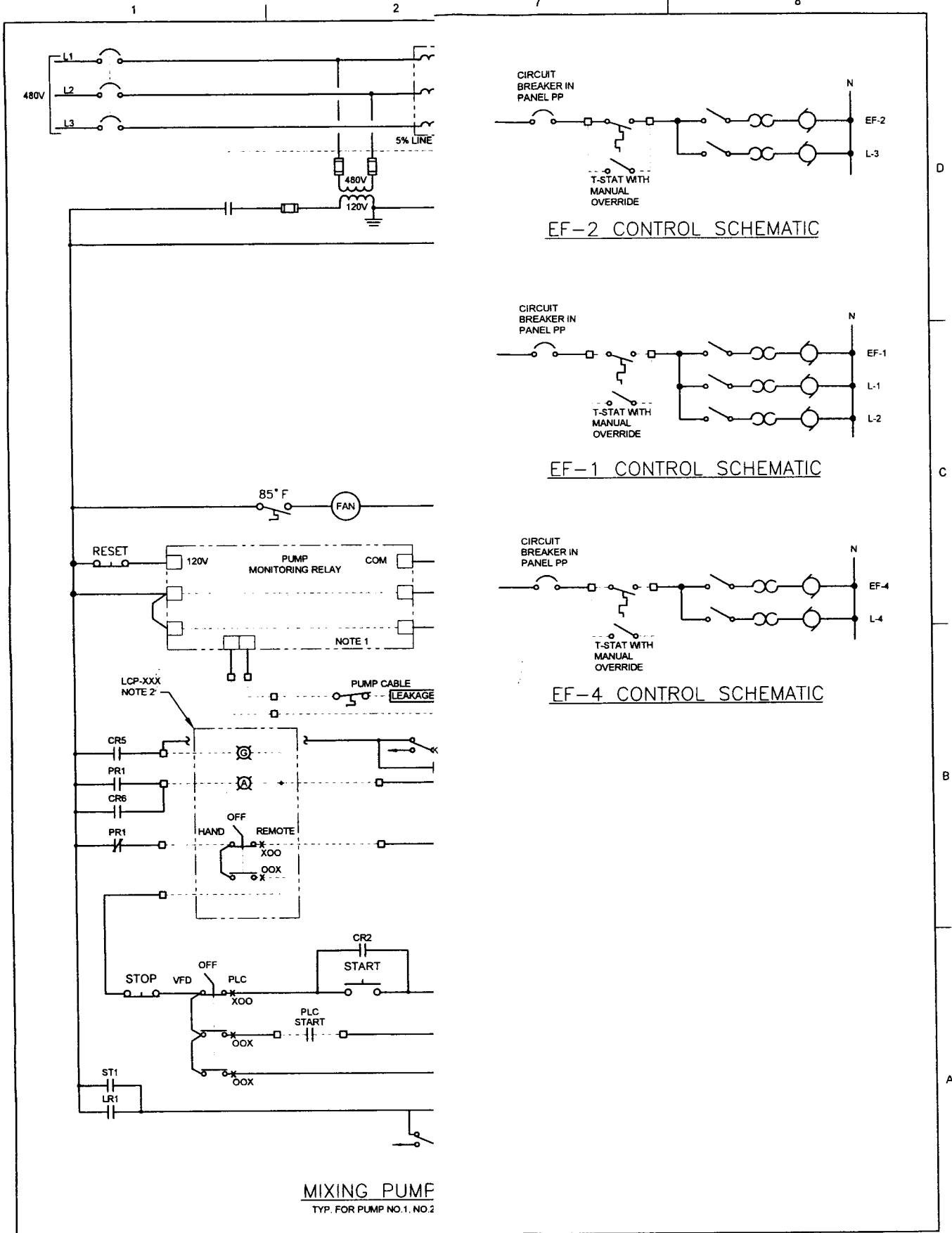

**MIXING PUMP**  
TYP. FOR PUMP NO.1, NO.2



MAIN	
2	9/1
1	9/2
ISSUE	DI

**CONTROL DIAGRAMS**

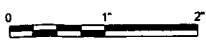

FILENAME | 01E-04.dwg  
SCALE | NONE

SHEET  
**01E-04**





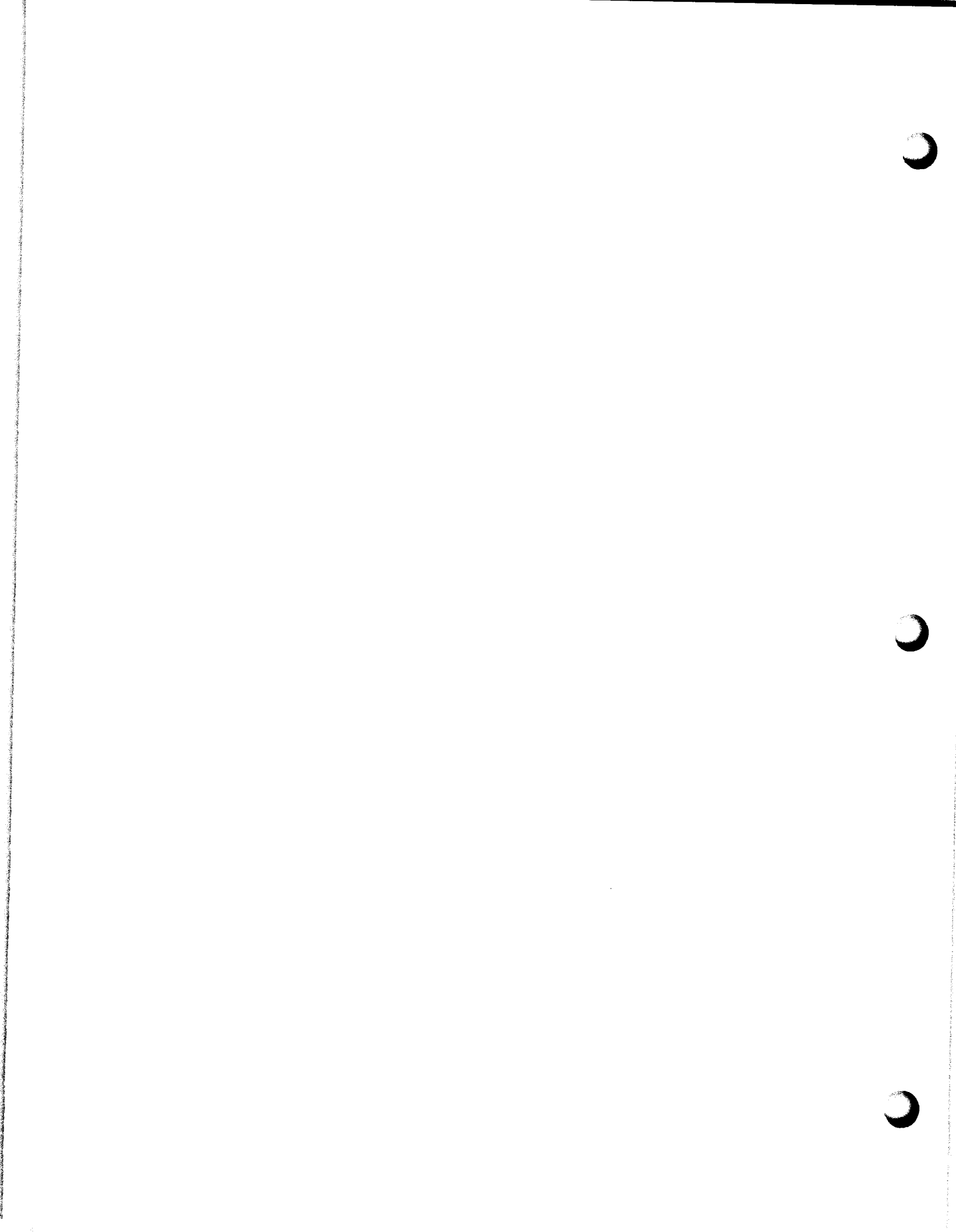

**KEY NOTES:**

- ① SURFACE MOUNT FIXTURE TO CEILING.
- ② WALL MOUNT FIXTURE AT 12'-0" AFF.
- ③ WALL MOUNT FIXTURE WITH BOTTOM OF FIXTURE 1" ABOVE TOP OF ADJACENT OVERHEAD DOOR FRAMES, APPROXIMATELY 14'-4" AFF.
- ④ WALL MOUNT FIXTURE WITH BOTTOM OF FIXTURE 1" ABOVE TOP OF OVERHEAD DOOR FRAME, APPROXIMATELY 18'-4" AFF.
- ⑤ HAND-OFF-AUTO SELECTOR SWITCH TO CONTROL EXTERIOR LIGHTING.
- ⑥ CONNECT BATTERY PACK IN FIXTURE TO UNSWITCHED CONDUCTORS.
- ⑦ ALL ELECTRICAL WORK IN THIS ROOM TO COMPLY WITH NFPA HAZARDOUS AREA CLASSIFICATION CLASS1, DIVISION 2, GROUPS C & D.
- ⑧ ALL ELECTRICAL WORK IN THIS ROOM TO COMPLY WITH NFPA HAZARDOUS AREA CLASSIFICATION CLASS1, DIVISION 1, GROUPS C & D.

**GENERAL NOTES:**

- 1. REFER TO SHEET 01E-06 FOR LIGHT FIXTURE SCHEDULE.
- 2. REFER TO SHEET 01E-02 FOR CIRCUIT CALLOUTS.

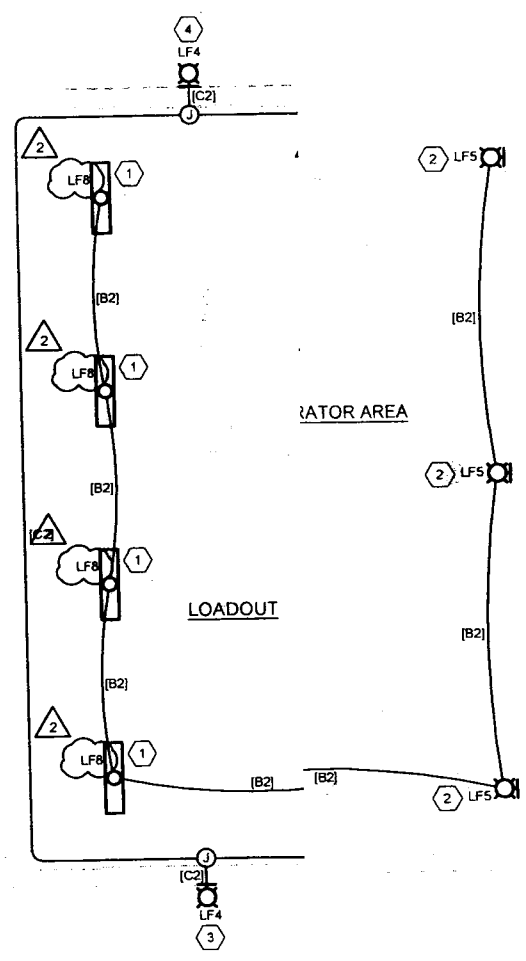

MAIN	
2	9/
1	9
ISSUE	1

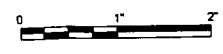

**PUMP STATION  
UPPER FLOOR PLAN  
LIGHTING**

FILENAME | 01E-07.dwg  
SCALE | 3/16" = 1'-0"

SHEET  
**01E-07**



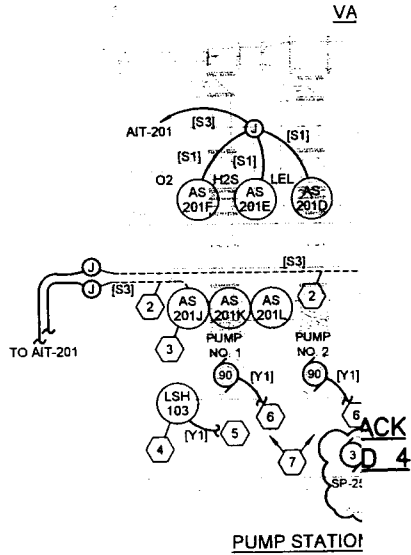

IM AND  
ITIONS  
WELDS

AND  
OUR

**LOWER AND INTERMEDIATE**

**KEY NOTES:**

- 1 PRESSURE TRANSDUCER IN STILLING WELL. COORDINATE EXACT LOCATION WITH INSTALLED EQUIPMENT. SEE MOUNTING DETAIL SHEET 01Y-06.
- 2 ROUTE 3/4" CONDUIT WITH CABLE SUPPLIED WITH EQUIPMENT UNDER WETWELL SLAB.
- 3 MOUNT TO WETWELL CEILING.
- 4 HIGH LEVEL FLOAT SWITCH.
- 5 FLOAT CABLE PROVIDED WITH EQUIPMENT UP TO CONDUIT WITH BELL END. SEE UPPER PLAN FOR CONTINUATION. SUPPORT FLOAT CABLE WITH STAINLESS STEEL WIRE MESH TYPE CORD GRIPS.
- 6 PUMP POWER AND CONTROL CABLES PROVIDED WITH EQUIPMENT UP TO PEDESTAL MOUNTED ENCLOSURE ABOVE. SEE UPPER PLAN FOR CONTINUATION. SUPPORT PUMP CABLES WITH STAINLESS STEEL WIRE MESH TYPE CORD GRIPS.
- 7 ALL ELECTRICAL WORK IN THIS AREA TO COMPLY WITH NFPA HAZARDOUS AREA CLASSIFICATION CLASS 1, DIVISION 1, GROUPS C & D.
- 8 WEATHERPROOF GROUND FAULT INTERRUPTER TYPE DUPLEX RECEPTACLE MOUNTED NEAR TOP OF EQUIPMENT RACK WITH 2-#10, 1-#10 GROUND TO PANEL LP IN ELECTRICAL BUILDING
- 9 ELECTRICAL EQUIPMENT RACK. SEE DETAIL THIS SHEET
- 10 NEMA 4X STAINLESS STEEL JUNCTION BOX FOR FLOAT SWITCH.
- 11 200 AMP 3-POLE, 600 VOLT, NON-FUSED DISCONNECT SWITCH IN NEMA 4X ENCLOSURE, TYPICAL OF 4.
- 12 3-#1/0, 1-#6 GND, 2-#14 CONTROL IN 2" CONDUIT FOR PUMP POWER WIRING AND CONTROL WIRING FOR DISCONNECT INTERLOCK.
- 13 FURNISH AND INSTALL CLASS 1, DIVISION 1 SEALING FITTING, TYPICAL OF 16.
- 14 NEMA 4X STAINLESS STEEL JUNCTION BOX, FOR CONNECTION TO PUMP, WITH TERMINAL STRIP FOR POWER AND CONTROL CONDUCTORS. ONE TERMINAL FOR EACH CONDUCTOR. PROVIDE BARRIER IN BOX TO SEPERATE LOW VOLTAGE AND POWER SIGNALS. BOND BOX TO EQUIPMENT GROUND, TYPICAL OF 4.
- 15 CROUSE-HINDS CGB (COPPER FREE ALUMINUM) CORD FITTING OR EQUIVALENT SIZED FOR EACH CORD, TYPICAL OF 6.
- 16 FURNISH AND INSTALL 8" x 8" EXPANDED METAL (ALUMINUM) WIREWAY, WITH HINGED DOOR AND LOCK HASP, AS MANUFACTURED BY U.S.F. FABRICATION, INC. ANCHOR TO CONCRETE SLAB USING 1" x 4" STAINLESS STEEL CONCRETE ANCHOR BOLTS, TYPICAL OF 6.
- 17 POWER/SIGNAL CABLES FURNISHED WITH PUMP MOTOR OR LEVEL DEVICE, TYPICAL OF 6.
- 18 CONDUIT TO WET WELL. SEAL WITH SILICONE RUBBER, TYPICAL OF 6.
- 19 16-#14, IN 1" CONDUIT FOR DISCONNECT INTERLOCK, SELECTOR SWITCH, PUMP OVERTEMP AND SEAL LEAK CONTROL, TYPICAL OF 4.
- 20 3-#1/0, 1-#6 GND IN 2" CONDUIT TO VFD IN ELECTRICAL BUILDING FOR PUMP POWER, TYPICAL OF 4.
- 21 1-2/C SHIELDED CABLES IN 1" CONDUIT TO ELECTRICAL BUILDING.
- 22 6-#14 IN 3/4" CONDUIT TO LCP-200 IN ELECTRICAL BUILDING
- 23 NEMA 4X STAINLESS STEEL JUNCTION BOX FOR CONNECTION TO LEVEL TRANSDUCER AND PUMP MONITOR CABLES WITH SIGNAL LINE PROTECTION AND INTRINSIC BARRIER. SEE DETAIL DRAWING 01Y-06.
- 24 NEMA 4X STAINLESS STEEL LOCAL CONTROL PANEL. SEE CONTROL DIAGRAM SHEET 01E107, TYPICAL OF 4.
- 25 6-#14 IN 3/4" CONDUIT, TYPICAL OF 4.
- 26 ARRANGE DISCONNECT SWITCHES, JUNCTION BOXES, CONDUIT, ETC. ON BACKBOARD AS REQUIRED. JUNCTION BOXES MAY BE ON BACK SIDE OF BOARD, DISCONNECT SWITCHES AND CONTROL STATIONS TO FACE PUMPS.
- 27 1-2/C SHIELDED PUMP MONITOR CABLE IN 3/4" CONDUIT
- 28 2-2/C SHIELDED PUMP MONITOR CABLES IN 1" CONDUIT TO ELECTRICAL BUILDING.

**GENERAL NOTES:**

- 1. REFER TO SHEET 01E-06 FOR LIGHT FIXTURE SCHEDULE.
- 2. REFER TO SHEET 01E-02 FOR CIRCUIT CALLOUTS.



2	9/
1	9/
ISSUE	D



FILENAME | 01E-08.dwg  
SCALE | 3/16" = 1'-0"

SHEET  
**01E-08**

**PUMP STATION  
INTERMEDIATE AND LOWER PLAN  
POWER**









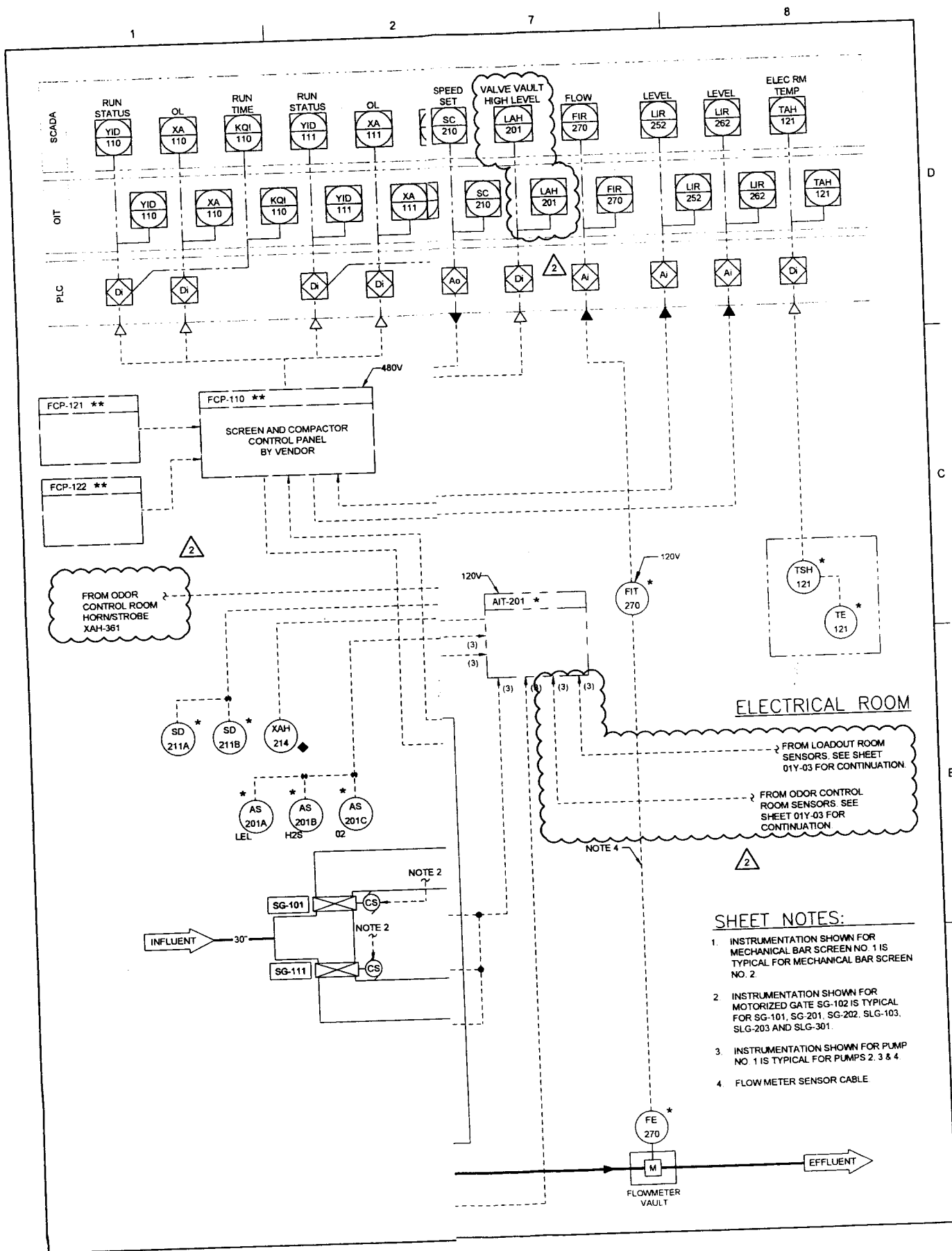

- SHEET NOTES:**
1. INSTRUMENTATION SHOWN FOR MECHANICAL BAR SCREEN NO. 1 IS TYPICAL FOR MECHANICAL BAR SCREEN NO. 2
  2. INSTRUMENTATION SHOWN FOR MOTORIZED GATE SG-102 IS TYPICAL FOR SG-101, SG-201, SG-202, SLG-103, SLG-203 AND SLG-301.
  3. INSTRUMENTATION SHOWN FOR PUMP NO. 1 IS TYPICAL FOR PUMPS 2, 3 & 4.
  4. FLOW METER SENSOR CABLE



2	9/
1	9/
ISSUE	C

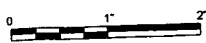

**SCREEN ROOM AND WETWELL P&ID**

FILENAME | 01Y-02.dwg  
SCALE | NONE

SHEET  
**01Y-02**

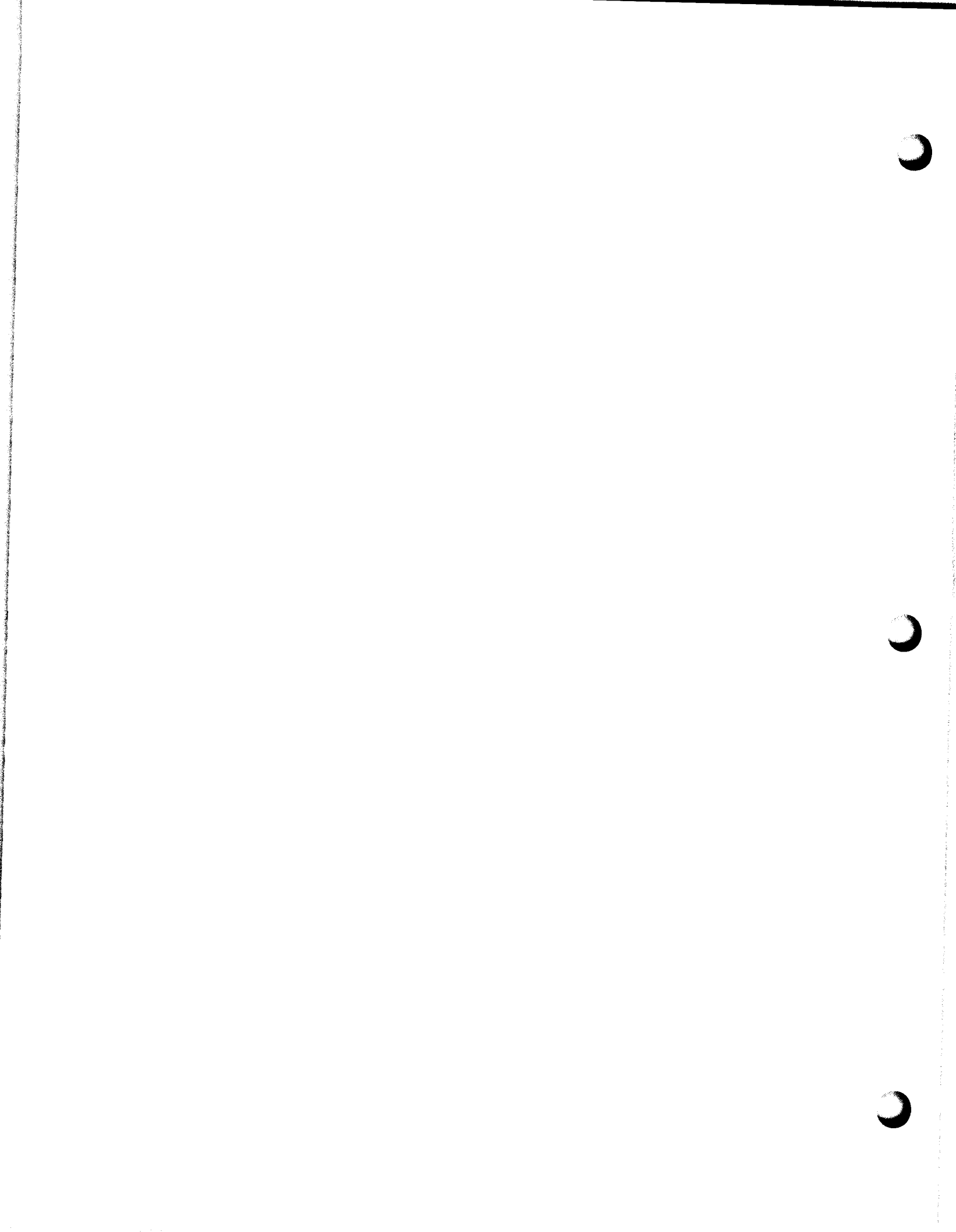

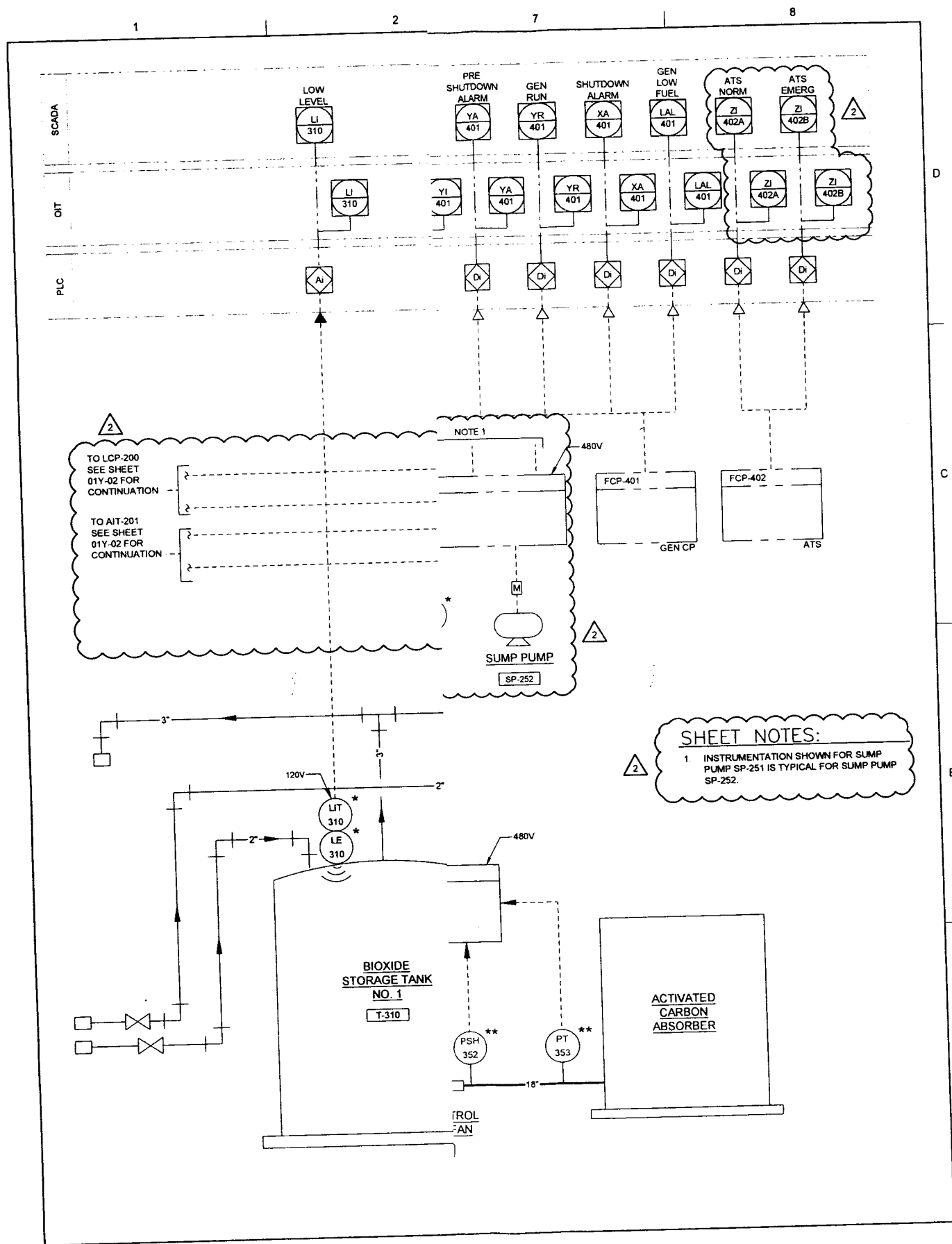

MAIN	
2	9/1
1	9/1
ISSUE	D

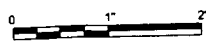

**ODOR CONTROL AND CHEMICAL FEED P&ID**

FILENAME 01Y-03.dwg  
SCALE NONE

SHEET 01Y-03

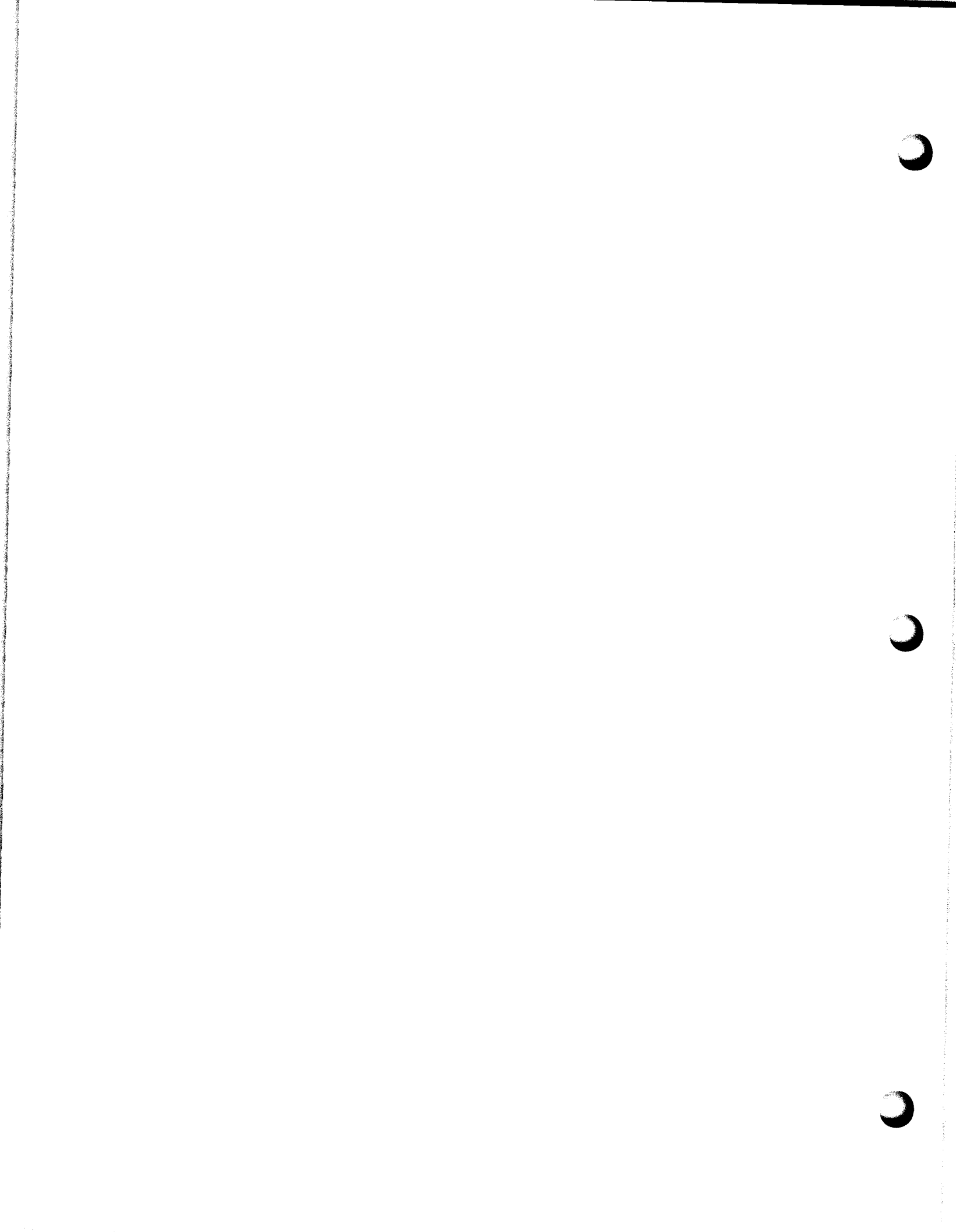







MAYOR JIM GRAY



**LEXINGTON**

TODD SLATIN  
DIRECTOR  
CENTRAL PURCHASING

**ADDENDUM #7**

Bid Number: #106-2017

Date: September 19, 2017

Subject: Expansion Area 3 Pump Station (Contract 1) and Force Main  
(Contract 2) Improvements

Address inquiries to:  
Brian Marcum  
(859) 258-3320

**TO ALL PROSPECTIVE SUBMITTERS:**

**Please be advised of the following clarifications to the above referenced bid:**

The odor control ductwork is PVC, as shown on the drawings, and FRP as specified in 15892 added in Addendum#6. The material for the ductwork, dampers and transition pieces can be either PVC or FRP.

Todd Slatin, Director  
Division of Central Purchasing

All other terms and conditions of the bid and specifications are unchanged. This letter should be signed, attached to and become a part of your submittal.

COMPANY NAME: \_\_\_\_\_

ADDRESS: \_\_\_\_\_

SIGNATURE OF BIDDER: \_\_\_\_\_



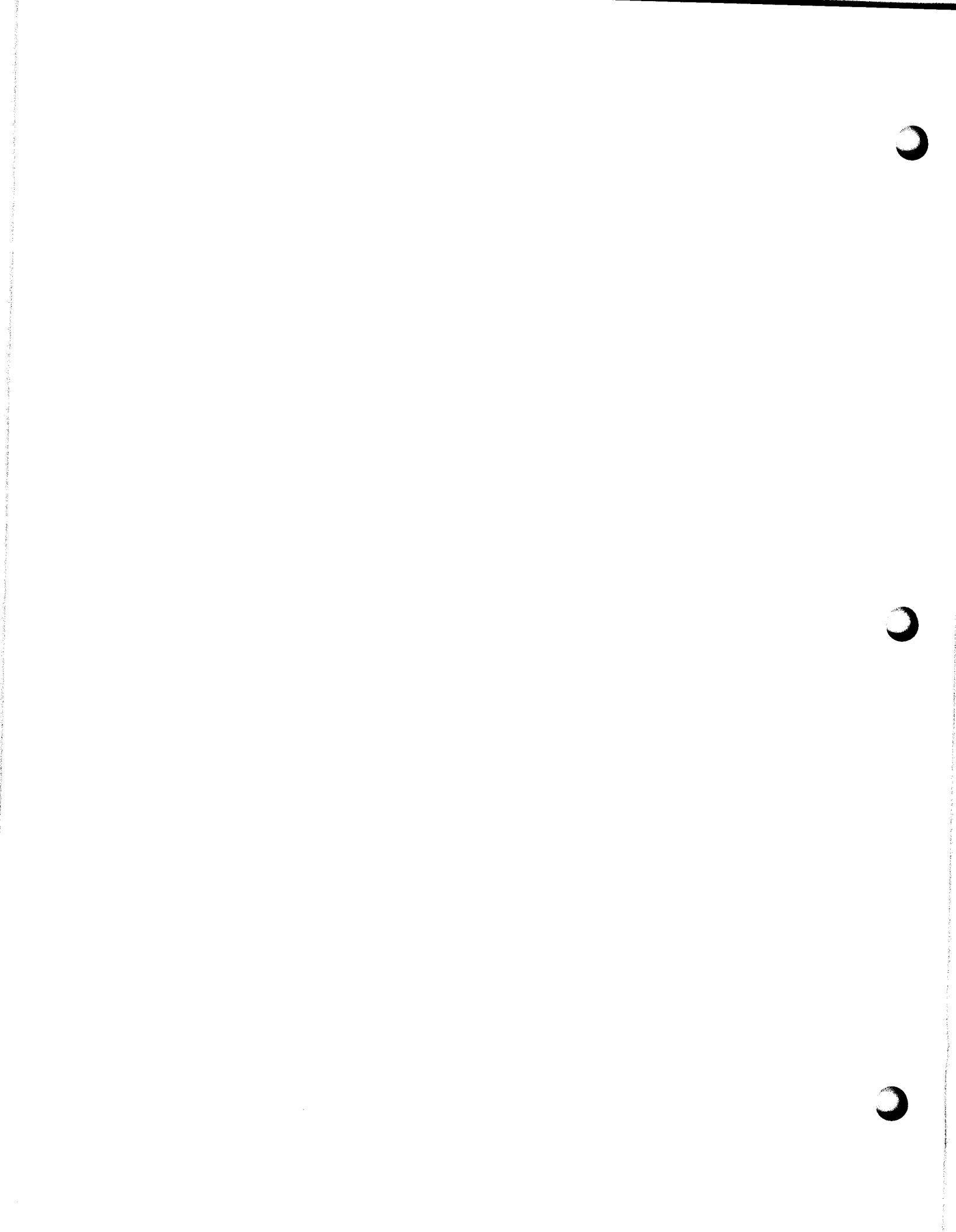

MAYOR JIM GRAY



**LEXINGTON**

TODD SLATIN  
DIRECTOR  
CENTRAL PURCHASING

**ADDENDUM #8**

Bid Number: #106-2017

Date: September 22, 2017

Subject: Expansion Area 3 Pump Station (Contract 1) and Force Main  
(Contract 2) Improvements

Address inquiries to:  
Brian Marcum  
(859) 258-3320

**TO ALL PROSPECTIVE SUBMITTERS:**

**Please be advised of the following clarifications to the above referenced bid:**

There is a conflict between the Contract Plans and Contract Specifications with respect to force main pipe material from station 10+00 to station 65+51. The Contract Specifications shall prevail. The following pipe materials are approved equals for force main pipe material from station 10+00 to station 65+51.

- Polyvinyl Chloride (PVC)
- Ductile Iron (DI)
- Fiberglass Reinforced Polymer Mortar (FRPM)
- Prestressed Concrete Cylinder Pipe (PCCP)

Todd Slatin, Director  
Division of Central Purchasing

All other terms and conditions of the bid and specifications are unchanged. This letter should be signed, attached to and become a part of your submittal.

COMPANY NAME: \_\_\_\_\_



ADDRESS: \_\_\_\_\_

SIGNATURE OF BIDDER: \_\_\_\_\_

