



**CONTRACT DOCUMENTS
AND
SPECIFICATIONS**

DIVISION OF PARKS & RECREATION

FOR

**SOUTHLAND PARK
TENNIS COURT RENOVATION**

Bid No. 6 -2014

Set # 1

Mayors Copy

TABLE OF CONTENTS
CONTRACT DOCUMENTS
Southland Park
Tennis Court Renovation

PART I	ADVERTISEMENT FOR BIDS
PART II	INFORMATION FOR BIDDERS
PART III	FORM OF PROPOSAL
PART IV	GENERAL CONDITIONS
PART V	SPECIAL CONDITIONS
PART VI	CONTRACT AGREEMENT
PART VII	PERFORMANCE AND PAYMENT BONDS
PART VIII	ADDENDA
PART IX	TECHNICAL SPECIFICATIONS AND PLANS

PART 1

ADVERTISEMENT FOR BIDS

INDEX

1.	INVITATION	AB-2
2.	DESCRIPTION OF WORK	AB-2
3.	OBTAINING PLANS, SPECIFICATIONS, AND BID DOCUMENTS	AB-2
4.	METHOD OF RECEIVING BIDS.....	AB-3
5.	METHOD OF AWARD	AB-3
6.	BID WITHDRAWAL.....	AB-3
7.	BID SECURITY	AB-3
8.	SUBMISSION OF BIDS	AB-3
9.	RIGHT TO REJECT.....	AB-4
10.	NOTIFICATION TO THE LFUCG FOR AFFIRMATIVE ACTION	AB-4
11.	NOTICE CONCERNING DBE GOAL.....	AB-4
12.	PRE-BID MEETING	AB-5

ADVERTISEMENT FOR BIDS

1. INVITATION

Sealed proposals for the following work will be received by the Lexington-Fayette Urban County Government (LFUCG) until 2:00 p.m., local time, **February 2, 2016**, for furnishing all labor and/or materials and performing all work as set forth by this advertisement, conditions (general and special), specifications, and/or the drawings prepared by and for Lexington-Fayette Urban County Government, Division of Parks and Recreation. Immediately following the scheduled closing time for reception of bids, all proposals which have been submitted in accordance with the above will be publicly opened and read aloud.

2. DESCRIPTION OF WORK

Consisting of the construction and/or furnishing of items as listed in the Bid Schedule beginning on page P-6, Part III, Form of Proposal, of this document, for the Southland Park Tennis Court Renovation, Lexington-Fayette County, Kentucky.

3. OBTAINING PLANS, SPECIFICATIONS, AND BID DOCUMENTS

Specifications, Plans, and Bid Documents may be examined at the following places:

LFUCG
Division of Central Purchasing
200 East Main Street, Third Floor, Rm 338
Lexington, Kentucky 40507
(859) 258-3320

LFUCG
Division of Parks and Recreation
469 Parkway Drive
Lexington, Kentucky 40504

4. METHOD OF RECEIVING BIDS

Bids will be received from Prime Contracting firms on a **Lump Sum** for total Project. The Bidder must include a price for all bid items to be considered. Bids shall be submitted in the manner and subject to the conditions as set forth and described in the Instruction to Bidders and Special Conditions.

Sealed bids shall be clearly marked on the outside of the container as follows: Company Name and Address, Bid Invitation Number, and the Project Name. Bids are to remain sealed until official Bid closure time.

Mailed bids/proposals should be sent to the Director, Division of Central Purchasing, 200 East Main Street, Lexington, KY 40507.

5. METHOD OF AWARD

The Contract, if awarded, will be to the lowest, qualified responsible bidder for the total project whose qualifications indicate the award will be in the best interest of the OWNER and whose bid/proposal complies with all the prescribed requirements. No Notice of Award will be given until the OWNER has concluded such investigation as deemed necessary to establish the responsibility, qualifications and financial ability of Bidders to do the work in accordance with the Contract Documents to the satisfaction of the OWNER within the time prescribed. The OWNER reserves the right to reject the Bid of any Bidder who does not pass such investigation to the OWNER's satisfaction. In analyzing Bids, the OWNER may take into consideration alternate and unit prices, if requested by the Bid forms.

6. BID WITHDRAWAL

No bidder may withdraw his bid for a period of sixty (60) calendar days after the closing date for receipt of bids. Errors and omissions will not be cause for withdrawal of bid without forfeit of bid bond. Bids may be withdrawn in person prior to the closing date of receipt of bids.

7. BID SECURITY

If the bid is \$50,000 or greater, bid shall be accompanied by a certified /cashier's check or bid bond payable to the Lexington-Fayette Urban County Government in an amount not less than Five Percent (5%) of the base bid. Bid bond shall be executed by a Surety Company authorized to do business in the Commonwealth of Kentucky and countersigned by a licensed Kentucky Resident Agent, representing the Surety Company. Bid Bonds are not required for bids under \$50,000. A certified check or cashier's check is also acceptable forms of bid security.

8. SUBMISSION OF BIDS

CONTRACTORS shall submit their bids to the Lexington-Fayette Urban County Government, Division of Purchasing, Third Floor, 200 East Main Street, Lexington, Kentucky 40507. Bids shall be submitted in a sealed envelope not later than 2:00 p.m. local

time, February 2, 2016. Sealed proposals shall be clearly marked on the outside of the container as follows: Company Name and Address, Bid Invitation Number, and Project Name to be opened at 2:00 p.m. local time February 2, 2016. Bids are to remain sealed until official Bid closure time. Bids received after the scheduled closing time for receipt of bids will not be considered and will be returned unopened.

9. RIGHT TO REJECT

The Lexington-Fayette Urban County Government reserves the right to reject any and all bids and to waive all informalities and/or technicalities where the best interest of the Lexington-Fayette Urban County Government may be served.

10. NOTIFICATION TO THE LEXINGTON-FAYETTE URBAN COUNTY GOVERNMENT FOR AFFIRMATIVE ACTION PLAN AND CURRENT WORKFORCE

The successful bidder must submit with their bid the following items to the Lexington-Fayette Urban County Government:

1. Affirmative Action Plan for his/her firm.
2. Current Workforce Analysis Form.

Failure to submit these items as required herein may result in disqualification of the Bidder from the award of the contract.

All submissions should be directed to:

Lexington-Fayette Urban County Government
Division of Purchasing
200 East Main Street, 3rd Floor, Room 338
Lexington, Kentucky 40507

11. NOTICE CONCERNING MWDBE GOAL

Notice of requirement for Affirmative Action to ensure Equal Employment Opportunities and Disadvantaged Business Enterprises (DBE) Contract participation. Disadvantaged Business Enterprises (DBE) consists of Minority-Owned Business Enterprises (MBE) and Woman-Owned Business Enterprises (WBE).

The Lexington-Fayette Urban County Government has set a goal that not less than ten percent (10%) of the total value of this Contract be subcontracted to Disadvantaged Business Enterprises, which is made up of MBEs and WBEs. The goal for the utilization of Disadvantaged Business Enterprises as subcontractors is a recommended goal. Contractor(s) who fail to meet such goal will be expected to provide written explanations to the Director of the Division of Purchasing of efforts they have made to accomplish the recommended goal, and the extent to which they are successful in accomplishing the

recommended goal will be a consideration in the procurement process. Depending on the funding source, other DBE goals may apply.

For assistance in locating Disadvantaged Business Enterprises Subcontractors contact:

Sherita Miller, Division of Central Purchasing
Lexington-Fayette Urban County Government
200 East Main Street, 3rd Floor, Room 338
Lexington, Kentucky 40507

12. PRE-BID MEETING

A non-mandatory pre-bid meeting will be held at 10:00 AM local time on January 26, 2016 at 469 Parkway, Lexington, KY 40504.

END OF SECTION

PART II
INFORMATION FOR BIDDERS

INDEX

1.	RECEIPT AND OPENING OF BIDS	IB-2
2.	PREPARATION OF BID.....	IB-2
3.	SUBCONTRACTS.....	IB-2
4.	QUALIFICATION OF BIDDER	IB-3
5.	BID SECURITY	IB-4
6.	LIQUIDATED DAMAGES FOR FAILURE TO ENTER INTO CONTRACT.....	IB-4
7.	TIME OF COMPLETION AND LIQUIDATED DAMAGES.....	IB-4
8.	EXAMINATION OF CONTRACT DOCUMENTS AND SITE.....	IB-5
9.	ADDENDA AND INTERPRETATIONS	IB-5
10.	SECURITY FOR FAITHFUL PERFORMANCE	IB-6
11.	POWER OF ATTORNEY	IB-6
12.	TAXES AND WORKMEN'S COMPENSATION	IB-6
13.	LAWS AND REGULATIONS	IB-6
14.	EROSION AND SEDIMENT CONTROL AND PERMITS	IB-6
15.	PREVAILING WAGE LAW AND MINIMUM HOURLY RATES.....	IB-7
16.	AFFIRMATIVE ACTION PLAN.....	IB-7
17.	CONTRACT TIME.....	IB-7
18.	SUBSTITUTION OR "OR-EQUAL" ITEMS.....	IB-7
19.	ALTERNATE BIDS.....	IB-8
20.	SIGNING OF AGREEMENT.....	IB-8
21.	ASSISTANCE TO BE OFFERED TO DBE CONTRACTORS.....	IB-8
22.	LFUCG NON-APPROPRIATION CLAUSE.....	IB-10



PART II

INFORMATION FOR BIDDERS

1. RECEIPT AND OPENING OF BIDS

The Lexington-Fayette Urban County Government (herein called the OWNER) invites bids from firms on the project described in the Advertisement for Bids. The OWNER will receive bids at the Division of Purchasing, at the time and in the manner set forth in the Advertisement for Bids, and the Bids will then be publicly opened and read aloud. The OWNER may consider informal any bid not prepared and submitted in accordance with the provisions hereof and may waive any informalities or reject any and all bids. Any bid may be withdrawn prior to the scheduled time for the opening of bids or authorized postponement thereof. Any bid received after the time and date specified shall not be considered. No bidder may withdraw a bid within 60 days after the actual time and date of the bid opening, but OWNER may, in its sole discretion, release any bid and return the Bid Security prior to that date.

The Lexington-Fayette Urban County Government assumes no responsibility for bids that are not addressed and delivered as indicated above. Bids that are not delivered to the Division of Central Purchasing by the stated time and date will be rejected.

2. PREPARATION OF BID

Each bid must be submitted on the prescribed Form of Proposal. All blank spaces for the bid prices must be filled in, either in ink or typewritten, for both unit prices and extensions. Totals for each bid item must be added to show the total amount of the bid. Each bid must be submitted in a sealed envelope bearing on the outside the name of the bidder, their address, the name of the project, the invitation number and time and date for which the bid is submitted. Bids must be addressed to the Director of Purchasing, Lexington-Fayette Urban County Government, Third Floor, 200 East Main Street, Lexington, Kentucky 40507. If forwarded by mail, the sealed envelope containing the bid must be enclosed in another envelope addressed as specified above.

3. SUBCONTRACTS

The bidder is specifically advised that any person, firm, or other party to whom it is proposed to award a subcontract under this Contract must be acceptable to the OWNER. All proposed subcontractors must be identified on the Form of Proposal. Prior to the award of Contract, the OWNER or the OWNER'S representative will advise the CONTRACTOR of the acceptance and approval thereof or of any action necessary to be taken. Should any Subcontractor be rejected by the OWNER, the CONTRACTOR shall present a new name and/or firm to the OWNER at no change in the Contract Price.

4. QUALIFICATION OF BIDDER

The OWNER may make such investigations as the OWNER deems necessary to determine the ability of the bidder to perform the Work, and the bidder shall furnish to the OWNER all such information and data for this purpose as the OWNER may request. The OWNER reserves the right to reject any bid if the evidence submitted by, or investigation of, such bidder fails to satisfy the OWNER that such bidder is properly qualified to carry out the obligations of the Contract and to complete the Work contemplated therein. Conditional bids will not be accepted.

In evaluating Bids, OWNER shall consider the qualifications of the BIDDERS, whether or not the Bids comply with the prescribed requirements, and alternatives and unit prices, as requested. OWNER may consider maintenance requirements, performance data, and disruption or damage to private property. It is OWNER'S intent to accept alternatives, if requested by the bid forms, in the order in which they are listed in the Bid Form but OWNER may accept or decline them in any order or combination. The contract, if awarded, will be awarded to the lowest, qualified, responsible BIDDER based upon OWNER'S evaluation which indicates that the award will be in the best interest of OWNER and the general public.

In the event there is any question as to the bidder's qualifications and ability to complete the work, a final determination will be made in accordance with a fair evaluation by the Urban County Government of the above listed elements.

- A. If the OWNER requires filling out a detailed financial statement, the bidder may provide its current certified financial statement(s) for the required time interval.
- B. Corporate firms are required to be registered and in good standing with the requirements and provisions of the Office of the Secretary of State, Commonwealth of Kentucky.
- C. Good standing with Public Works Act - any CONTRACTOR and/or subcontractors in violation of any wage or work act provisions (KRS 337.510 to KRS 337.550) are prohibited by Statutory Act (KRS 337.990) from bidding on or working on any and all public works contracts, either in their name or in the name of any other company, firm or other entity in which he might be interested. No bid from a prime contractor in violation of the Act can be considered, nor will any subcontractor in violation of the Act be approved and/or accepted. The responsibility for the qualifications of the subcontractor is solely that of the prime contractor.
- D. Documents Required of CONTRACTOR - (1) A sworn statement signed by the President or owner of the Company regarding all current work in progress anywhere; (2) A document showing the percent of completion of each project and the total worth of each project; and (3) Documentation showing the percentage of the DBE employment levels on each project of the Bidder's current work force, and DBE participation levels for Subcontractors.

- E. Optional OWNER Requirements - The OWNER, at its discretion, may require the BIDDER/CONTRACTOR to provide: (1) a current detailed financial statement for a period including up to 3 prior years; (2) financial security or insurance in amounts and kinds acceptable to the OWNER to meet the financial responsibility requirements for the CONTRACTOR to indemnify the OWNER. (3) Additional information and/or DBE work force data, as well as DBE participation data.

Each bidder agrees to waive any claim it has or may have against the Owner, the Consultant, and their respective employees, arising out of or in connection with the administration, evaluation, or recommendation of any bid.

5. BID SECURITY

- A. Each bid must be accompanied by a bid bond prepared on a Form of Bid Bond and attached hereto, duly executed by the bidder as principal and having as surety thereon a surety company approved by the OWNER, in the amount of 5% of the bid. Such bid bond will be returned to the unsuccessful bidder(s) only upon written request to the Director of Central Purchasing within seven (7) days of opening of bids. Bid bond shall be made payable to the Lexington-Fayette Urban County Government. Bid security is not required for projects under \$50,000.
- B. Bonds shall be placed with an agent licensed in Kentucky with surety authorized to do business within the state. When the premium is paid for such coverage, the full commission payable shall be paid to such local agent who shall not divide such commission with any person other than a duly licensed resident local agent.

6. LIQUIDATED DAMAGES FOR FAILURE TO ENTER INTO CONTRACT

The successful bidder, upon his failure or refusal to execute and deliver the Contract and bonds required within ten (10) days after he has received notice of the acceptance of his bid, shall forfeit to the OWNER, as liquidated damages for such failure or refusal, the security deposited with his bid.

7. TIME OF COMPLETION AND LIQUIDATED DAMAGES

Bidder must agree to commence work on or before a date to be specified in a written "Notice to Proceed" from the OWNER and to fully complete the Project within the time as specified in the Contract. Bidder must agree also to pay **\$100.00** per day as liquidated damages, or the sum as specified in the Contract for each consecutive calendar day thereafter as hereinafter provided in the General Conditions.

8. EXAMINATION OF CONTRACT DOCUMENTS AND SITE

- A. It is the responsibility of each Bidder before submitting a Bid, to (a) examine the Contract Documents thoroughly, (b) visit the site(s) to become familiar with local conditions that may affect cost, progress, performance or furnishing of the work, (c) consider Federal, State and Local laws and regulations that may affect cost, progress, performance or furnishing of the work, (d) study and carefully correlate Bidder's observations with the Contract Documents, and (e) notify Consultant of all conflicts, errors or discrepancies in the Contract Documents.
- B. Bidders should examine the requirements of section 4 of the General Conditions for information pertaining to subsurface conditions, underground structures, underground facilities, and availability of lands, easements, and rights-of-way. The completeness of data, presented in the Contract Documents, pertaining to subsurface conditions, underground structures, and underground facilities for the purposes of bidding or construction is not assured. The Bidder will, at Bidder's own expense, make or obtain any additional examinations, investigations, explorations, tests and studies and obtain any additional information and data which pertain to the physical conditions (surface and subsurface) which may affect cost, progress, performance or furnishing of the Work and which Bidder deems necessary to determine its Bid for performing and furnishing the Work in accordance with the time, price, and other terms and conditions of the Contract Documents. On request in advance, OWNER will provide access to the site to conduct such explorations and tests as each Bidder deems necessary for submission of a bid. Bidder shall fill all holes, clean up and restore the site to its former condition upon completion of such explorations.
- C. The submission of a Bid will constitute an incontrovertible representation by the Bidder that Bidder has complied with every requirement of this paragraph 8; that without exception the Bid is premised upon furnishing and performing the Work required by the Contract Documents and such means, methods, techniques, sequences or procedures of construction as may be indicated in or required by the Contract Documents; and that the Contract Documents are sufficient in scope and detail to indicate and convey understanding of all terms and conditions for performance and furnishing of the Work.

9. ADDENDA AND INTERPRETATIONS

No interpretation of the meaning of the Contract Documents will be made to any bidder orally. Every request for such interpretation should be in writing addressed to the Director of Central Purchasing, who in turn will have an Addendum issued for the Lexington-Fayette Urban County Government, and to be given consideration must be received prior to the date fixed for the opening of bids. Any and all such interpretations and any supplemental instructions will be in the form of written addenda to the specifications. Acknowledgement of the receipt of addenda must be included with all submitted bids. Failure of any bidder to receive any such addendum or interpretation shall not relieve such bidder from any obligation under his bid as submitted. All addenda so issued shall become part of the Contract Documents.

10. SECURITY FOR FAITHFUL PERFORMANCE

- A. Simultaneously with his delivery of the executed Contracts, the CONTRACTOR shall furnish a surety bond or bonds as security for the faithful performance of this Contract and for payment of all persons performing labor on the Project under this Contract and furnishing materials in connection with this Contract, as specified in the General Conditions. The surety on such bond or bonds shall be a duly authorized surety company satisfactory to the OWNER and authorized to do business in the Commonwealth of Kentucky.
- B. All bonds required by this Contract and laws of this State shall be placed with agents licensed in the State of Kentucky. When the premium is paid for such coverage's, the full commission shall be paid to such local agent who shall not divide such commission with any person other than a duly licensed resident local agent.
- C. **Contractor shall use standard Performance and Payment Bond forms such as documents provided with this contract book or AIA form A312-1984 (or later). Each document will be for 100% of the Contract Bid Amount.**

11. POWER OF ATTORNEY

Attorney-in-fact who signs bid bonds or contract bonds must file with each bond a certified and effectively dated copy of their power of attorney.

12. TAXES AND WORKMEN'S COMPENSATION

The CONTRACTOR and subcontractor will be required to accept liability for payment of all payroll taxes, sales and use tax, and all other taxes or deductions required by local, state or federal law, such as old age pension, social security, or annuities measured by wages. Each shall carry Workmen's Compensation Insurance to the full amounts as required by Statutes and shall include the cost of all foregoing items in the proposal. The CONTRACTOR will not otherwise be reimbursed or compensated for such tax payments. The CONTRACTOR is urged to ascertain at his own risk his actual tax liability in connection with the execution or performance of his Contract.

13. LAWS AND REGULATIONS

The bidder's attention is directed to the fact that all applicable state laws, municipal ordinances, and the rules and regulations of all authorities having jurisdiction over construction of the Project shall apply to the Contract throughout, and they will be deemed to be included in the contract, the same as though herein written out in full.

14. EROSION AND SEDIMENT CONTROL AND PERMITS

The CONTRACTOR and Subcontractors performing work on projects on behalf of the OWNER shall also comply with all applicable federal, state, and local environmental

regulations and all requirements and conditions set forth in "special" permits including but not limited to Corp of Engineers 404 permits, 401 Water Quality Certifications, Stream Crossing and Floodplain Encroachment Permits as described in Part 4 General Conditions Paragraph 5.17.

15. PREVAILING WAGE LAW AND MINIMUM HOURLY RATES

Federal or state wage rates and regulations, if required for this Project, will be as described in the Special Conditions.

16. AFFIRMATIVE ACTION PLAN

The successful Bidder must submit with their bid, the following items to the Urban County Government:

1. Affirmative Action Plan of the firm
2. Current Work Force Analysis Form
3. Good Faith Effort Documentation
4. List of Disadvantaged Business Enterprise Subcontractors and the Dollar Value of each Subcontract

A Work Force Analysis Form shall be submitted for each Contract. Failure to submit these items as required herein may result in disqualification of the Bidder from award of the Contract.

All submissions should be directed to:

Director, Division of Central Purchasing
Lexington-Fayette Urban County Government
200 East Main Street, Third Floor
Lexington, KY 40507

17. CONTRACT TIME

The number of calendar days within which the Work is to be substantially completed and ready for final payment (the Contract Time) is set forth in the Form of Proposal and the Agreement.

18. SUBSTITUTE OR "OR-EQUAL" ITEMS

The Contract, if awarded, will be on the basis of materials and equipment described in the Drawings or specified in the Specifications without consideration of possible substitute or "or-equal" items. Whenever it is indicated in the Drawings or specified in the Specifications that a substitute or "or-equal" item of material or equipment may be furnished or used by the CONTRACTOR if acceptable to the CONSULTANT and

OWNER, application for such acceptance will not be considered by the CONSULTANT and OWNER until after the effective date of the Agreement. The procedure for submission of any such application by the CONTRACTOR and consideration by the CONSULTANT and OWNER is set forth in the General Conditions.

19. ALTERNATE BIDS

Bidders shall submit alternate bids/proposals only if and when such alternate bids/proposals have been specifically requested in an Invitation for Bids. If alternate bids/proposals are requested in an Invitation for Bids, the form of submission of such alternate bid and the conditions under which such alternate bids will be considered for award of a contract will be established in the Invitation.

Any Bidder who submits a bid incorporating an alternate proposal when alternate bids/proposals have not been requested in the Invitation for Bids shall have his/her bid rejected as non-responsive.

Any Bidder who submits a bid incorporating two (2) or more prices for an item or groups of items (unless such method of pricing is requested in the Invitation for Bids), or which imposes conditions for acceptance other than those established in the Invitation for Bids, shall have their bid rejected as non-responsive.

20. SIGNING OF AGREEMENT

When OWNER gives a Notice of Award to the successful Bidder, it will be accompanied by the required number of unsigned counterparts of the Agreement with all other written Contract Documents attached. Within ten days thereafter, CONTRACTOR shall sign and deliver the required number of counterparts of the Agreement and attached documents to OWNER with the required Bonds, Certificate of Insurance, and Power of Attorney. The OWNER will deliver one fully signed counterpart to CONTRACTOR at such time as it has been signed by the Mayor.

21. ASSISTANCE TO BE OFFERED TO DISADVANTAGED BUSINESS ENTERPRISE (MWDBE) CONTRACTORS

A. Outreach for MWDBE(s)

The Lexington-Fayette Urban County Government (LFUCG) maintains a database of MWDBE contractors and organizations. When a LFUCG construction project is advertised for bidding, notices are sent to companies registered at <https://lfucg.economicengine.com>. The notices describe the project and indicate the deadline for submitting bids.

If you wish to be added to the LFUCG MWDBE contractor database, please contact:

Sherita Miller, Division of Central Purchasing
Lexington-Fayette Urban County Government
200 East Main Street, Room 338
Lexington, Kentucky 40507
mclark@lexingtonky.gov

B. Bid Bond Assistance for MWDBE(s)

For those MWDBE contractors who wish to bid on LFUCG project, bid bond assistance is available. This bid bond assistance is in the form of a "Letter of Certification" which is accepted by the LFUCG's Division of Purchasing, in lieu of a bid bond. The "Letter of Certification" must be included in the bid package when it is submitted to the Division of Purchasing. The "Letter of Certification" will reference the specific project for which the bid is being submitted, and the time and date on which the bid is due. Bid bond assistance must be requested from the Lexington-Fayette Urban County Government's Division of Central Purchasing.

C. Eligibility for Bid Bond Assistance for MWDBE(s)

In order to be eligible for any Bid bonding assistance, a MWDBE construction company must be owned or controlled at the level of 51% or more by a member or members of a minority group or females. Prior to receiving assistance, a statement providing evidence of ownership and control of the company by a member or members of a minority group or females must be signed by the Owner or corporate officer and by an attorney or accountant submitted to:

Sherita Miller, Division of Central Purchasing
Lexington-Fayette Urban County Government
200 East Main Street, Room 338
Lexington, Kentucky 40507
mclark@lexingtonky.gov

D. MWDBE Subcontractors

The LFUCG will, upon request, assist prime contractors in the procurement of eligible DBE subcontractors in an effort to achieve 10% minimum MWDBE goal.

For a list of eligible subcontractors, please contact:

Sherita Miller, Division of Central Purchasing
Lexington-Fayette Urban County Government
200 East Main Street, Room 338
Lexington, Kentucky 40507
smiller@lexingtonky.gov

22. LFUCG NON-APPROPRIATION CLAUSE

Contractor acknowledges that the LFUCG is a governmental entity, and the contract validity is based upon the availability of public funding under the authority of its statutory mandate.

In the event that public funds are unavailable and not appropriated for the performance of the LFUCG's obligations under this contract, then this contract shall automatically expire without penalty to the LFUCG thirty (30) days after written notice to Contractor of the unavailability and non-appropriation of public funds. It is expressly agreed that the LFUCG shall not activate this non-appropriation provision for its convenience or to circumvent the requirements of this contract, but only as an emergency fiscal measure during a substantial fiscal crisis, which affects generally its governmental operations.

In the event of a change in the LFUCG's statutory authority, mandate and mandated functions, by state and federal legislative or regulatory action, which adversely affects the LFUCG's authority to continue its obligations under this contract, then this contract shall automatically terminate without penalty to the LFUCG upon written notice to Contractor of such limitation or change in the LFUCG's legal authority.

PART III
FORM OF PROPOSAL

INDEX

1.	FORM OF PROPOSAL	P-2
2.	LEGAL STATUS OF BIDDER.....	P-4
3.	BIDDERS AFFIDAVIT	P-5
4.	BID SCHEDULE – SCHEDULE OF VALUES	P-6
5.	STATEMENT OF BIDDER'S QUALIFICATIONS	P-10
6.	LIST OF PROPOSED SUBCONTRACTORS	P-13
7.	LEXINGTON FAYETTE URBAN COUNTY GOVERNMENT MWDDBE PARTICIPATION GOALS, FORMS, AND GOOD FAITH EFFORTS	P-14
8.	AUTHENTICATION OF BID AND STATEMENT OF NON-COLLUSION AND NON-CONFLICT OF INTEREST.....	P-26
9.	STATEMENT OF EXPERIENCE.....	P-27
10.	EQUAL OPPORTUNITY AGREEMENT.....	P-29
11.	EQUAL EMPLOYMENT OPPORTUNITY AFFIRMATIVE ACTION POLICY	P-32
12.	WORKFORCE ANALYSIS	P-33
13.	EVIDENCE OF INSURABILITY	P-34
14.	DEBARRED FIRMS.....	P-35
15.	DEBARRED CERTIFICATION	P-36

PART III

Invitation to Bid No.

**Southland Park
Tennis Court Renovation**

1. FORM OF PROPOSAL

Place: Lexington, Kentucky

Date: 2/2/2016

The following Form of Proposal shall be followed exactly in submitting a proposal for this Work.

This Proposal Submitted by Tennis Technology, Inc.
PO Box 19709 Louisville, KY 40259
(Name and Address of Bidding Contractor)

(Hereinafter called "Bidder"), organized and existing under the laws of the State of Kentucky, doing business as a corporation
"a corporation," "a partnership", or an "individual" as applicable.

To: Lexington-Fayette Urban County Government
(Hereinafter called "OWNER")
Office of the Director of Purchasing
200 East Main Street, 3rd Floor
Lexington, KY 40507

Gentlemen:

The Bidder, in compliance with your Invitation for Bids for Tennis Court Renovation, Southland having examined the Plans and Specifications with related documents, having examined the site for proposed Work, and being familiar with all of the conditions surrounding the construction of the proposed Project, including the availability of materials and labor, hereby proposes to furnish all labor, materials, and supplies, and to construct the Project in accordance with the Contract Documents, within the time set forth therein, and at the lump sum and/or unit prices stated hereinafter. These prices are to cover all expenses incurred in performing the Work required under the Contract Documents, of which this proposal is a part. The OWNER will issue work orders for work to be performed under this Contract.

BIDDER hereby agrees to commence work under this contract on or before a date to be specified in the Notice to Proceed and to fully complete the project within the time provided in the

Purchase Order or Work Orders issued by the OWNER. BIDDER further agrees to pay liquidated damages, the sum of \$100.00 for each consecutive calendar day thereafter.

The Bidder hereby acknowledges receipt of the following addenda:

Addendum No. 1 Date 1/27/16

Addendum No. 2 Date 2/2/16

Addendum No. Date

Addendum No. Date

Addendum No. Date

Addendum No. Date

Addendum No. Date

Addendum No. Date

Insert above the number and the date of any Addendum issued and received. If none has been issued and received, the word "NONE" should be inserted.

2. **LEGAL STATUS OF BIDDER**

Bidder Tennis Technology Inc

Date 2/2/2016

* 1. A corporation duly organized and doing business under the laws of the State of Kentucky, for whom Jeff Henderson, bearing the official title of President, whose signature is affixed to this Bid/Proposal, is duly authorized to execute contracts.

* 2. A Partnership, all of the members of which, with addresses are: (Designate general partners as such)

~~_____

_____~~

* 3. An individual, whose signature is affixed to this Bid/Proposal (please print name)

~~_____
_____~~

*(The Bidder shall fill out the appropriate form and strike out the other two.)

3. **BIDDERS AFFIDAVIT**

Comes the Affiant, Jeff Henderson, and after being first duly sworn, states under penalty of perjury as follows:

1. His/her name is Jeff Henderson and he/she is the individual submitting the bid or is the authorized representative of Tennis Technology Inc, the entity submitting the bid (hereinafter referred to as "Bidder").
 2. Bidder will pay all taxes and fees, which are owed to the Lexington-Fayette Urban County Government at the time the bid is submitted, prior to award of the contract and will maintain a "current" status in regard to those taxes and fees during the life of the contract.
 3. Bidder will obtain a Lexington-Fayette Urban County Government business license, if applicable, prior to award of the contract.
 4. Bidder has authorized the Division of Central Purchasing to verify the above-mentioned information with the Division of Revenue and to disclose to the Urban County Council that taxes and/or fees are delinquent or that a business license has not been obtained.
 5. Bidder has not knowingly violated any provision of the campaign finance laws of the Commonwealth of Kentucky within the past five (5) years and the award of a contract to the Bidder will not violate any provision of the campaign finance laws of the Commonwealth.
 6. Bidder has not knowingly violated any provision of Chapter 25 of the Lexington-Fayette Urban County Government Code of Ordinances, known as the "Ethics Act."
 7. Bidder acknowledges that "knowingly" for purposes of this Affidavit means, with respect to conduct or to circumstances described by a statute or ordinance defining an offense, that a person is aware or should have been aware that his conduct is of that nature or that the circumstance exists.
- Further, Affiant sayeth naught.

[Signature]

(Affiant)

STATE OF Kentucky
COUNTY OF Jefferson

The foregoing instrument was subscribed, sworn to and acknowledged before me by Jeff Henderson on this the 9th day of February, 2016.

My Commission expires: 9 February 2020

[Signature]

NOTARY PUBLIC, STATE AT LARGE

AGNES KARLEENE COX
NOTARY PUBLIC
Kentucky, State At Large
I.D. # 460107
My Commission Expires 2/9/2020

4. BID SCHEDULE – SCHEDULE OF VALUES

The Bidder agrees to perform all the Work described in the Specifications and shown on the Plans for the following proposed lump sum and/or unit prices, if applicable, which shall include the furnishing of all labor, materials, supplies, equipment and/or vehicle usage, services, all items of cost, overhead, taxes (federal, state, local), and profit for the Contractor and any Subcontractor involved, within the time set forth herein. If unit prices are applicable, Bidder must make the extensions and additions showing the total amount of bid.

Form of proposal must include unit bid prices written in words, unit price written in numbers and total amount bid (unit price x quantity) per line item OR bid may be considered non-responsive. In case of price discrepancy, unit bid price written in words will prevail followed by unit price written in numbers then total amount bid per line item.

If a discrepancy between the unit price and the item total exists, the unit price prevails except:

If the unit price is illegible, omitted, or the same as the item total, item total prevails and the unit price is the quotient of the item total and the quantity.

If the unit price and the item total are illegible or are omitted, the bid may be determined nonresponsive. If a lump sum total price is illegible or is omitted, the bid may be determined nonresponsive.

For a lump sum based bid, the item total is the bid amount the Division uses for bid comparison.

For a unit price based bid, the sum of the item totals is the bid amount the Division uses for bid comparison.

The LFUCG reserves the right to accept base bids and/or alternates in any order in the best interest of the government. The LFUCG's decision on the bid amount is final.

Item No.	Description w/Unit Bid Price Written in Words	Unit	Total Bid Amount
1.	<p>Base Bid - Remove asphalt to gravel base. Compact base as necessary to ensure proctor density. Reset net standards re-sleeved in concrete. Apply new asphalt 1 1/2" base course, milled asphalt can be utilized in base course. Apply 1 1/2" of surface asphalt in accordance with attached "court spec". Replace galvanized fencing and posts. Color coat court. Environmental controls as listed in special considerations. All in accordance with Contract Documents</p> <p><u>NINETY</u> <u>NINE FIFTY FOUR</u> Dollars <u>20</u> Cents</p>	LS	\$ <u>95,954.00</u>

Item No.	Description w/Unit Bid Price Written in Words	Unit	Total Bid Amount
2.	Add Alternate #1 Apply new asphalt with aramid fibers 1 1/4" base course, milled asphalt can be utilized in base course. Apply 1 1/4" of surface asphalt in accordance with attached "court spec" <u>THREE THOUSAND EIGHT NINETY FOUR</u> Dollars <u>N</u> Cents	LS	\$ <u>3894.00</u>
3.	Add Alternate #2 Install welded connections for galvanized fence fabric in accordance with Contract Documents _____ Dollars _____ Cents	LS	\$ <u>NO BID</u>
4.	Add Alternate #3 Supply and install tennis court standards in accordance with Contract Documents <u>NO</u> Dollars <u>NO</u> Cents	LS	\$ <u>NO BID</u> INCLUDED IN BASE
5.	Add Alternate #4 Upgrade galvanized fence to vinyl coated fence fabric in accordance with Contract Documents <u>SIX HUNDRED EIGHTY</u> Dollars <u>NO</u> Cents	LS	\$ <u>618.00</u>
6.	Add Alternate #5 Supply, assemble and install surface mount bench in accordance with Contract Documents <u>TWO THOUSAND EIGHT HUNDRED</u> Dollars <u>NO</u> Cents	LS	\$ <u>2800.00</u>

TOTAL OF ALL BID PRICES FOR Southland Park Tennis Court Renovation. In case of discrepancy, the amount shown in words will govern.

ONE HUNDRED THREE TWO SIXTY SIX

 (\$ 103,266.00)

LIST OF UNIT PRICES

The following List of Unit Prices is required by the Owner to be completely executed and submitted with each Bidder's Proposal. Each unit price shall include the furnishing of all labor, materials, supplies and services, and shall include all items of cost, overhead, and profit for the Contractor and any Sub-Contractors involved, and shall be used uniformly, without modification, for either additions or deductions from the Bid. These unit prices as established shall also be used to determine the equitable adjustment of the Contract Price in connection with changes, or extra work performed under the Contract. The "Rules of Measurement" set forth in the Special Conditions shall govern where volume units are concerned.

DESCRIPTION OF WORK	UNIT PRICE	
1. Silt Fence	<u>3.00</u>	LF
2. Grass Seed Mix	<u> </u>	AC
3. Straw Mulch	<u> </u>	SF
4. Concrete installed	<u>500.00</u>	CY
5. #57 stone	<u>22.00</u>	TN
6. Chain Link Fence Gate	<u>250.00</u>	EA
7. Court Color Coating	<u>4.25</u>	SY
8. Tennis Court Striping - 2"	<u>1.00</u>	LF
9. Asphalt Surface	<u>96.00</u>	TN
10. Asphalt Base	<u>95.00</u>	TN
11. Demolition & Removal or Bit. Concrete	<u>30.00</u>	CY

Submitted by:

Tennis Technology Inc
Firm

PO Box 19709
Address

Louisville, KY 40259
City, State & Zip

**Bid must be signed:
(original signature)**

[Handwritten Signature]
Signature of Authorized Company Representative - Title

Jeff Henderson
Representative/s Name (Typed or Printed)

502 969-8861 502 969 8871
Area Code - Phone - Extension Fax #

tenntech@bellsouth.net
E-Mail Address

OFFICIAL ADDRESS:

Tennis Technology Inc
PO Box 19709
Louisville, KY 40259

_____ (Seal if Bid is by Corporation)

By signing this form you agree to ALL terms, conditions, and associated forms in this bid package

Southland

5. STATEMENT OF BIDDER'S QUALIFICATIONS

The following statement of the Bidder's qualifications is required to be filled in, executed, and submitted with the Proposal:

- 1. Name of Bidder: Tennis Technology Inc
PO Box 19709
Louisville KY. 40259
- 2. Permanent Place of Business: 5510 Poplar Park Blvd.
Louisville, KY. 40228
- 3. When Organized: 1978
- 4. Where Incorporated: Kentucky
- 5. Construction Plant and Equipment Available for this Project:

<u>Loader</u>	<u>Trencher / Ditch litch</u>
<u>Backhoe</u>	<u>Compactors</u>
<u>Dump Truck</u>	<u>Various hand tools</u>
<u>Power</u>	
<u>Skid Steer</u>	
<u>Auger</u>	

(Attach Separate Sheet If Necessary)

6. Financial Condition:

If specifically requested by the OWNER, the apparent low Bidder is required to submit its latest three (3) years audited financial statements to the OWNER'S Division of Central Purchasing within seven (7) calendar days following the bid opening.

7. In the event the Contract is awarded to the undersigned, surety bonds will be furnished by:

Lexon Insurance Company (Surety)

Signed:  (Representative of Surety)

8. The following is a list of similar projects performed by the Bidder. (Attach separate sheet if necessary).

<u>NAME</u>	<u>LOCATION</u>	<u>CONTRACT SUM</u>
Various other Projects for LFUCB to date		
Silver Creek High School	Sellersburg, IN	527,523
Danville Board of Education	Danville, IN	386,103
North Posey High School	Poseyville, IN	174,00
Petersburg Park	Louisville, IN	294,880

9. The Bidder has now under contract and bonded the following projects:

<u>NAME</u>	<u>LOCATION</u>	<u>CONTRACT SUM</u>
Morgan County Board of Education	Scylesville, KY	\$377007.30
Sun Valley Tennis Courts	Louisville, IN	\$159715.
_____	_____	_____
_____	_____	_____
_____	_____	_____

10. List Key Bidder Personnel who will work on this Project.

<u>NAME</u>	<u>POSITION DESCRIPTION</u>	<u>NO. OF YEARS WITH BIDDER</u>
Jeff Henderson	President	38
William R Nunn	Project Manager	33
William T Milam	Project Manager	23
Mike Devere	Project Manager	13
Jose Lopez	Project Manager	8

11. DBE Participation on current bonded projects under contract:

<u>SUBCONTRACTORS</u> <u>(LIST)</u>	<u>PROJECT</u> <u>(SPECIFIC TYPE)</u>	<u>DBE</u>	<u>% of WORK</u>
_____	_____	_____	_____
_____	_____	_____	_____
_____	_____	_____	_____
_____	_____	_____	_____
_____	_____	_____	_____
_____	_____	_____	_____
_____	_____	_____	_____

(USE ADDITIONAL SHEETS IF NECESSARY)

12. We acknowledge that, if we are the apparent low Bidder, we may be required to submit to the OWNER within 7 calendar days following the Bid Opening, a sworn statement regarding all current work on hand and under contract, and a statement on the OWNER'S form of the experience of our officers, office management and field management personnel. Additionally, if requested by the OWNER, we will within 7 days following the request submit audited financial statements and loss history for insurance claims for the 3 most recent years (or a lesser period stipulated by the OWNER).

6. LIST OF PROPOSED SUBCONTRACTORS

The following list of proposed subcontractors is required by the OWNER to be executed, completed and submitted with the BIDDER'S FORM OF PROPOSAL. All subcontractors are subject to approval of the Lexington-Fayette Urban County Government. Failure to submit this list completely filled out may be cause for rejection of bid.

BRANCH OF WORK - LIST EACH MAJOR ITEM Such as: Grading, bituminous paving, concrete, seeding and protection, construction staking, etc.	SUBCONTRACTOR	DBE Yes/No	% of Work
1. <u>Asphalt</u>	Name: <u>McGloire Construction</u> <u>836 N. College St.</u> Address: <u>Fernoxburg, KY. 40330</u>	<u>NO</u>	<u>27%</u>
2. <u>Fencing</u>	Name: <u>Myers Fencing Co.</u> <u>5001 Park Central Dr</u> Address: <u>Nicholasville, KY. 40356</u>	<u>NO</u>	<u>13%</u>
3. _____	Name: _____	_____	_____
4. _____	Address: _____	_____	_____
5. _____	Name: _____	_____	_____
6. _____	Address: _____	_____	_____
7. _____	Name: _____	_____	_____
8. _____	Address: _____	_____	_____

(Attach additional sheet(s) if necessary.)



LFUCG MWDBE PARTICIPATION FORM

Bid/RFP/Quote Reference # 6-2016

The MWDBE subcontractors listed have agreed to participate on this Bid/RFP/Quote. If any substitution is made or the total value of the work is changed prior to or after the job is in progress, it is understood that those substitutions must be submitted to Central Purchasing for approval immediately.

MWDBE Company, Name, Address, Phone, Email	Work to be Performed	Total Dollar Value of the Work	% Value of Total Contract
1.			
2.			
3.			
4.			

The undersigned company representative submits the above list of MWDBE firms to be used in accomplishing the work contained in this Bid/RFP/Quote. Any misrepresentation may result in the termination of the contract and/or be subject to applicable Federal and State laws concerning false statements and false claims.

Tennis Technology Inc
Company

[Signature]
Date 2-9-16

[Signature]
Company Representative

President
Title



LFUCG MWDBE SUBSTITUTION FORM
 Bid/RFP/Quote Reference # 6-2016

The substituted MWDBE subcontractors listed below have agreed to participate on this Bid/RFP/Quote. These substitutions were made prior to or after the job was in progress. These substitutions were made for reasons stated below and are now being submitted to Central Purchasing for approval. By the authorized signature of a representative of our company, we understand that this information will be entered into our file for this project.

SUBSTITUTED MWDBE Company Name, Address, Phone, Email	MWDBE Formally Contracted/ Name, Address, Phone, Email	Work to Be Performed	Reason for the Substitution	Total Dollar Value of the Work	% Value of Total Contract
1.					
2.					
3.					
4.					

The undersigned acknowledges that any misrepresentation may result in termination of the contract and/or be subject to applicable Federal and State laws concerning false statements and false claims.

Tennis Technology Inc
 Company
2-9-16
 Date

[Signature]
 Company Representative
President
 Title



MWDBE QUOTE SUMMARY FORM

Bid/RFP/Quote Reference # 6-2016

The undersigned acknowledges that the minority subcontractors listed on this form did submit a quote to participate on this project.

Company Name	Contact Person
Address/Phone/Email	Bid Package / Bid Date

MWDBE Company Address	Contact Person	Contact Information (work phone, Email, cell)	Date Contacted	Services to be performed	Method of Communication (email, phone meeting, ad, event etc)	Total dollars \$\$ Do Not Leave Blank (Attach Documentation)	MBE * AA HA AS NA Female

(MBE designation / AA=African American / HA= Hispanic American/AS = Asian American/Pacific Islander/ NA= Native American)

The undersigned acknowledges that all information is accurate. Any misrepresentation may result in termination of the contract and/or be subject to applicable Federal and State laws concerning false statements and claims

Tennis Technology Inc
Company
2-9-16
Date

[Signature]
Company Representative
President
Title



LFUCG SUBCONTRACTOR MONTHLY PAYMENT REPORT

The LFUCG has a 10% goal plan adopted by city council to increase the participation of minority and women owned businesses in the procurement process. In order to measure that goal LFUCG will track spending with MWDBE vendors on a monthly basis. By the signature below of an authorized company representative, you certify that the information is correct, and that each of the representations set forth below is true. Any misrepresentation may result in termination of the contract and/or prosecution under applicable Federal and State laws concerning false statements and false claims. Please submit this form monthly to the Division of Central Purchasing/ 200 East Main Street / Room 338 / Lexington, KY 40507.

Bid/RFP/Quote # 6-2016
 Total Contract Amount Awarded to Prime Contractor for this Project _____

Project Name/ Contract #	Work Period/ From: _____ To: _____
Company Name:	Address:
Federal Tax ID:	Contact Person:

Subcontractor Vendor ID (name, address, phone, email)	Description of Work	Total Subcontract Amount	% of Total Contract Awarded to Prime for this Project	Total Amount Paid for this Period	Purchase Order number for subcontractor work (please attach PO)	Scheduled Project Start Date	Scheduled Project End Date

By the signature below of an authorized company representative, you certify that the information is correct, and that each of the representations set forth below is true. Any misrepresentations may result in the termination of the contract and/or prosecution under applicable Federal and State laws concerning false statements and false claims.

 Company

 Date

 Company Representative

 Title

LFUCG STATEMENT OF GOOD FAITH EFFORTS

Bid/RFP/Quote # 6-2016

By the signature below of an authorized company representative, we certify that we have utilized the following Good Faith Efforts to obtain the maximum participation by MWDBE business enterprises on the project and can supply the appropriate documentation.

- _____ Advertised opportunities to participate in the contract in at least two (2) publications of general circulation media; trade and professional association publications; small and minority business or trade publications; and publications or trades targeting minority, women and disadvantaged businesses not less than fifteen (15) days prior to the deadline for submission of bids to allow MWDBE firms to participate.
- _____ Included documentation of advertising in the above publications with the bidders good faith efforts package
- _____ Attended LFUCG Central Purchasing Economic Inclusion Outreach event
- _____ Attended pre-bid meetings that were scheduled by LFUCG to inform MWDBEs of subcontracting opportunities
- _____ Sponsored Economic Inclusion event to provide networking opportunities for prime contractors and MWDBE firms
- _____ Requested a list of MWDBE subcontractors or suppliers from LFUCG Economic Engine and showed evidence of contacting the companies on the list(s).
- _____ Contacted organizations that work with MWDBE companies for assistance in finding certified MWDBE firms to work on this project. Those contacted and their responses should be a part of the bidder's good faith efforts documentation.
- _____ Sent written notices, by certified mail, email or facsimile, to qualified, certified MWDBEs soliciting their participation in the contract not less than seven (7) days prior to the deadline for submission of bids to allow them to participate effectively.
- _____ Followed up initial solicitations by contacting MWDBEs to determine their level of interest.
- _____ Provided the interested MWDBE firm with adequate and timely information about the plans, specifications, and requirements of the contract.
- _____ Selected portions of the work to be performed by MWDBE firms in order to increase the likelihood of meeting the contract goals. This includes, where appropriate, breaking out contract work items into economically feasible units to facilitate MWDBE participation, even when the prime contractor may otherwise perform these work items with its own workforce

The Entity (regardless of whether construction contractor, non-construction contractor or supplier) agrees to provide equal opportunity in employment for all qualified persons, to prohibit discrimination in employment because of race, color, creed, national origin, sex or age, and to promote equal employment through a positive, continuing program from itself and each of its sub-contracting agents. This program of equal employment opportunity shall apply to every aspect of its employment policies and practices.

The Kentucky equal Employment Opportunity Act of 1978 (KRS 45.560-45.640) requires that any count, city, town, school district, water district, hospital district, or other political subdivision of the state shall include in directly or indirectly publicly funded contracts for supplies, materials, services, or equipment hereinafter entered into the following provisions:

During the performance of this contract, the contractor agrees as follows:

- (1) *The contractor will not discriminate against any employee or applicant for employment because of race, color, religion, sex, age or national origin;*
- (2) *The contractor will state in all solicitations or advertisements for employees placed by or on behalf of the contractors that all qualified applicants will receive consideration for employment without regard to race, color, religion, sex, age or national origin;*
- (3) *The contract will post notices in conspicuous places, available to employees and applicants for employment, setting forth the provisions of the non-discrimination clauses required by this section; and*
- (4) *The contractor will send a notice to each labor union or representative of workers with which he has a collective bargaining agreement or other contract or understanding advising the labor union or workers' representative of the contractor's commitments under the nondiscrimination clauses.*

The Act further provides:

KRS 45.610. Hiring minorities – Information required

- (1) *For the length of the contract, each contractor shall hire minorities from other sources within the drawing area, should the union with which he has collective bargaining agreements be unwilling to supply sufficient minorities to satisfy the agreed upon goals and timetable.*
- (2) *Each contractor shall, for the length of the contract, furnish such information as required by KRS 45.560 to KRS 45.640 and by such rules, regulations and orders issued pursuant thereto and will permit access to all books and records pertaining to his employment practices and work sites by the contracting agency and the department for purposes of investigation to ascertain compliance with KRS 45.560 to 45.640 and such rules, regulations and orders issued pursuant thereto.*

KRS 45.620. Action against contractor – Hiring of minority contractor or subcontractor

- (1) *If any contractor is found by the department to have engaged in an unlawful practice under this chapter during the course of performing under a contract or subcontract covered under KRS 45.560 to 45.640, the department shall so certify to the contracting agency and such certification shall be binding upon the contracting agency unless it is reversed in the course of judicial review.*
- (2) *If the contractor is found to have committed an unlawful practice under KRS 45.560 to 45.640, the contracting agency may cancel or terminate the contract, conditioned upon a program for future compliance approved by the contracting agency and the department. The contracting agency may declare such a contractor ineligible to bid on further contracts with that agency until such time as the contractor complies in full with the requirements of KRS 45.560 - 45.640.*
- (3) *The equal employment provisions of KRS 45.560 to 45.640 may be met in part by a contractor by subcontracting to a minority contractor or subcontractor. For the provisions of KRS 45.560 to 45.640, a minority contractor or subcontractor shall mean a business that is owned and controlled by one or more persons disadvantaged by racial or ethnic circumstances.*

KRS 45.630 Termination of existing employee not required, when

Any provision of KRS 45.560 to 45.640 notwithstanding, no contractor shall be required to terminate an existing employee upon proof that that employee was employed prior to the date of the contract.

KRS 45.640 Minimum skills

Nothing in KRS 45.560 to 45.640 shall require a contractor to hire anyone who fails to demonstrate the minimum skills required to perform a particular job.

It is recommended that all of the provisions quoted above to be included as special conditions in each contract. In the case of a contract exceeding \$250,000, the contractor is required to furnish evidence that his work-force in Kentucky is representative of the available work-force in the area from which he draws employees, or to supply an Affirmative Action plan which will achieve such representation during the life of the contract.

11. **EQUAL EMPLOYMENT OPPORTUNITY AFFIRMATIVE ACTION POLICY**

It is the policy of Tennis Technology Inc

to assure that all applicants for employment and all employees are treated on a fair and equitable basis without regard to their race, religion, sex, color, handicap, natural origin or age.

Such action shall include employment, promotion, demotion, recruitment or recruitment advertising, layoff or termination, rates of pay and other forms of compensation, and selection for training, whether apprenticeship and/or on-the-job-training.

Furthermore, this company agrees to make special recruitment efforts to hire the protected class whenever feasible. This company also agrees to adhere to all applicable federal, state, and local laws relating to Equal Employment Opportunity for all individuals.

12. WORKFORCE ANALYSIS FORM

Name of Organization: Tennis Technology Inc Date: 2/21/2016

Categories	Total	White		Black		Other		Total	
		M	F	M	F	M	F	M	F
Administrators	1	1						1	
Professionals									
Superintendents									
Supervisors									
Foremen									
Technicians									
Protective Service									
Para-Professionals									1
Office/Clerical	1		1						
Skilled Craft	6	3				3		6	
Service/Maintenance	10	1		2		7		10	
Total:	18	4	1	2		10		17	1

Prepared By: Kathleen Cox

13. EVIDENCE OF INSURABILITY

LEXINGTON-FAYETTE URBAN COUNTY GOVERNMENT CONSTRUCTION PROJECT
(Use separate form for each Agency or Brokerage agreeing to provide coverage)

Name Insured Tennis Technology Inc
 Address PO Box 19709 Louisville, KY 40259
 Project to be insured Southland Park Tennis Court Renovation Bid C-2016
 Employee ID _____ Phone 502 969 8861

In lieu of obtaining certificates of insurance at this time, the undersigned agrees to provide the above Names Insured with the minimum coverage listed below. These are obtained in the Insurance and Risk Management of Part V (Special Conditions), including all requirements, and conditions.

Section Items	Coverage	Minimum Limits and Policy Requirements	Limits Provided To Insured	Name of Insurer	A.M. Best's Code	Rating
SC-3, Section 2, Part 4 1 - see provisions	CGI	\$1,000,000 per occ. And \$2,000,000 aggregate	\$1,000,000	AUTOOWNERS	18788	A++
SC-3, Section 2, Part 4 1 - see provisions	AUTO	\$2,000,000 per occ.	\$1,000,000	AUTOOWNERS	18788	A++
SC-3, Section 2, Part 4 1 - see provisions	WC	Statutory w/ endorsement as noted	\$			

Section 2 includes required provisions, statements regarding insurance requirements, and the undersigned agrees to abide by all provisions for the coverage checked above unless stated otherwise when submitting.

Agency of Brokerage Louisville FOS Network Name of Authorized Representative ERIC LIEDTKE
901 LILY CREEK RD #201 Title OWNER
 Street Address _____
 City Louisville Ky State Ky Zip 40343
502 473 8660 Authorized Signature Eric Liedtke
 Telephone Number _____ Date 2-4-16

NOTE: Authorized signatures may be the agent's if agent has placed insurance through an agency agreement with the insurer. If insurance is brokered, authorized signature must be that of authorized representative of insurer.

IMPORTANT: Contract may not be awarded if a completed and signed copy of this form for all coverage's listed above is not provided with the bid.

13. EVIDENCE OF INSURABILITY

LEXINGTON-FAYETTE URBAN COUNTY GOVERNMENT CONSTRUCTION PROJECT
(Use separate form for each Agency or Brokerage agreeing to provide coverage).

Name Insured: Femis Technology, Inc Employee ID: 502 969 8861
 Address: PO Box 19709 Louisville, KY 40259 Phone: 502 969 8861
 Project to be insured: Southland Park Tennis Court Renovation Bid C-2016

In lieu of obtaining certificates of insurance at this time, the undersigned agrees to provide the above named insured with the minimum coverage listed below. These are outlined in the Insurance and Risk Management of Part V (Special Conditions), including all requirements, and conditions.

Section Items	Coverage	Minimum Limits and Policy Requirements	Limits Provided To Insured	Name of Insurer	A.M. Best's Code	Rating
SC-3, Section 2, Part 4.1 - see provisions	COL	\$1,000,000 per occ. And \$2,000,000 aggregate	\$			
SC-3, Section 2, Part 4.1 - see provisions	AUTO	\$2,000,000 per occ.	\$			
SC-3, Section 2, Part 4.1 - see provisions	WC	Statutory w/ endorsement as noted	\$400,000 E.L. Statutory Benefits	KY Associated Service Co (Contract No. C553002)	C553002	A-VII

Section 2 includes required provisions, statements regarding insurance requirements, and the undersigned agrees to abide by all provisions for Cap coverage's checked above unless stated otherwise when submitting:

Agency or Brokerage: Assured Partners LLC Name of Authorized Representative: Sara E. Olwick
2305 River Road Senior Account Executive
 Street Address: Louisville KY 40206 The Authorized Signature: Sara E. Olwick
 City: Louisville State: KY Zip: 40206 Date: 2-4-16
 Telephone Number: 502-894-2100

NOTE: Authorized signatures may be the agent's if agent has placed insurance through an agency agreement with the insurer. If insurer is brokered, authorized signature must be that of authorized representative of insurer.

IMPORTANT: Contract may not be awarded if a completed and signed copy of this form for all coverage's listed above is not provided with the bid.

14. DEBARRED FIRMS

PROJECT NAME: Southland Park Tennis Court Renovation

BID NUMBER: 6-2016

LEXINGTON-FAYETTE URBAN COUNTY GOVERNMENT
LEXINGTON, KY

All prime Contractors shall certify that Subcontractors have not and will not be awarded to any firms that has been debarred for noncompliance with the Federal Labor Standards, Title VI of the Civil Rights Act of 1964 As Amended, Executive Order 11246 As Amended or any other Federal Law.

All bidders shall complete the attached certification in duplicate and submit both copies to the Owner with the bid proposal. The Owner (grantee) shall transmit one copy to the Lexington-Fayette Urban County Government, Division of Community Development, within fourteen (14) days after bid opening.

The undersigned hereby certifies that the firm of Tennis Technology Inc has not and will not award a subcontract, in connection with any contract award to it as the result of this bid, to any firm that has been debarred for noncompliance with the Federal labor Standards, Title VI of the civil Rights Act of 1964, Executive Order 11246 as amended or any Federal Law.

Tennis Technology Inc
Name of Firm Submitting Bid

Signature of Authorized Official

President
Title

2-9-16
Date

15. DEBARMENT CERTIFICATION

All contractors/subcontractors shall complete the following certification and submit it with the bid proposal.

The contractor/subcontractor certifies in accordance with Executive Order 12549 (Debarment and Suspension 2/18/86) that to the best of its knowledge and belief, that it and its principals:

- 1) Are not presently debarred, suspended, proposed for debarment, declared negligible, or voluntarily excluded from covered transactions or contract by any Federal department or agency for noncompliance with the Federal Labor Standards, Title VI of the Civil Rights Act of 1964 as amended, Executive Order 11246 as amended or any other Federal law;
 - a) Have not within a three year period preceding this proposal been convicted of or had a civil judgment rendered against them for commission of fraud or a criminal offense in connection with obtaining, attempting to obtain, or performing a public (Federal, State or local) transaction or contract under a public transaction; violation of Federal or State antitrust statutes or commission of embezzlement, theft, forgery, bribery, falsification or destruction of records, making false statements, or receiving stolen property;
 - b) Are not presently indicted for or otherwise criminally or civilly charged by a government entity (Federal, State or local) with commission of any of the offenses enumerated in paragraph (1)(a) of this certification; and
 - c) Have not within a three year period preceding this bid has one or more public (Federal, State or local) transactions or contracts terminated for cause or default.
- 2) Where the contractor is unable to certify to any of the statements in this certification, such prospective contractors shall attach an explanation to this certification form.

Firm Name: Tennis Technology Inc

Project: Southland Park Tennis Court Renovation

Printed Name and Title of Authorized Representative: Jeff Henderson President

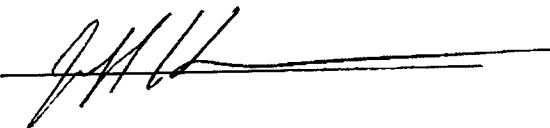
Signature: 

Date: 2-9-16

END OF SECTION

AIA Document A310™ – 2010

Bid Bond

CONTRACTOR:
(Name, legal status and address)

Tennis Technology, Inc
P. O. Box 19709
Louisville, KY 40259

SURETY:
(Name, legal status and principal place of business)

Lexon Insurance Company
10002 Shelbyville Rd., Suite 100
Louisville, KY 40223

This document has important legal consequences. Consultation with an attorney is encouraged with respect to its completion or modification.

OWNER:
(Name, legal status and address)

Lexington-Fayette Urban County Government
Division of Purchasing
200 E. Main St., 3rd Fl., Room 308
Lexington, KY 40507

Any singular reference to Contractor, Surety, Owner or other party shall be considered plural where applicable.

BOND AMOUNT: Five Percent of the Amount Bid

(\$ 5% of Bid)

PROJECT:
(Name, location or address, and Project number, if any)

Southland Park Tennis Court Renovation

The Contractor and Surety are bound to the Owner in the amount set forth above, for the payment of which the Contractor and Surety bind themselves, their heirs, executors, administrators, successors and assigns, jointly and severally, as provided herein. The conditions of this Bond are such that if the Owner accepts the bid of the Contractor within the time specified in the bid documents, or within such time period as may be agreed to by the Owner and Contractor, and the Contractor either (1) enters into a contract with the Owner in accordance with the terms of such bid, and gives such bond or bonds as may be specified in the bidding or Contract Documents, with a surety admitted in the jurisdiction of the Project and otherwise acceptable to the Owner, for the faithful performance of such Contract and for the prompt payment of labor and material furnished in the prosecution thereof; or (2) pays to the Owner the difference, not to exceed the amount of this Bond, between the amount specified in said bid and such larger amount for which the Owner may in good faith contract with another party to perform the work covered by said bid, then this obligation shall be null and void, otherwise to remain in full force and effect. The Surety hereby waives any notice of an agreement between the Owner and Contractor to extend the time in which the Owner may accept the bid. Waiver of notice by the Surety shall not apply to any extension exceeding sixty (60) days in the aggregate beyond the time for acceptance of bids specified in the bid documents, and the Owner and Contractor shall obtain the Surety's consent for an extension beyond sixty (60) days.

If this Bond is issued in connection with a subcontractor's bid to a Contractor, the term Contractor in this Bond shall be deemed to be Subcontractor and the term Owner shall be deemed to be Contractor.

When this Bond has been furnished to comply with a statutory or other legal requirement in the location of the Project, any provision in this Bond conflicting with said statutory or legal requirement shall be deemed deleted herefrom and provisions conforming to such statutory or other legal requirement shall be deemed incorporated herein. When so furnished, the intent is that this Bond shall be construed as a statutory bond and not as a common law bond.

Signed and sealed this 9th day of February 2016

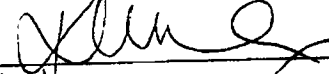
(Witness)

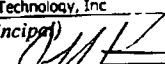
Tennis Technology, Inc
(Principal)  (Seal)

(Title) PRESIDENT
Lexon Insurance Company

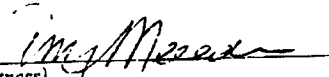
(Witness)

(Surety)  (Seal)

(Title) Sheryon Quinn
Attorney-in-Fact

Init.

POWER OF ATTORNEY

LX-264144

Lexon Insurance Company

KNOW ALL MEN BY THESE PRESENTS, that LEXON INSURANCE COMPANY, a Texas Corporation, with its principal office in Louisville, Kentucky, does hereby constitute and appoint: Brook T. Smith, Raymond M. Hundley, Jason D. Cromwell, James H. Martin, Barbara Duncan, Sandra L. Fusinetti, Mark A. Guidry, Jill Kemp, Lynnette Long, Amy Meredith, Deborah Neichter, Jessica Nowlin, Theresa Pickerrell, Sheryon Quinn, Bonnie J. Wortham, Beth Frymire its true and lawful Attorney(s)-In-Fact to make, execute, seal and deliver for, and on its behalf as surety, any and all bonds, undertakings or other writings obligatory in nature of a bond.

This authority is made under and by the authority of a resolution which was passed by the Board of Directors of LEXON INSURANCE COMPANY on the 1st day of July, 2003 as follows:

Resolved, that the President of the Company is hereby authorized to appoint and empower any representative of the Company or other person or persons as Attorney-In-Fact to execute on behalf of the Company any bonds, undertakings, policies, contracts of indemnity or other writings obligatory in nature of a bond not to exceed \$5,000,000.00, Five Million dollars, which the Company might execute through its duly elected officers, and affix the seal of the Company thereto. Any said execution of such documents by an Attorney-In-Fact shall be as binding upon the Company as if they had been duly executed and acknowledged by the regularly elected officers of the Company. Any Attorney-In-Fact, so appointed, may be removed for good cause and the authority so granted may be revoked as specified in the Power of Attorney.

Resolved, that the signature of the President and the seal of the Company may be affixed by facsimile on any power of attorney granted, and the signature of the Assistant Secretary, and the seal of the Company may be affixed by facsimile to any certificate of any such power and any such power or certificate bearing such facsimile signature and seal shall be valid and binding on the Company. Any such power so executed and sealed and certificate so executed and sealed shall, with respect to any bond of undertaking to which it is attached, continue to be valid and binding on the Company.

IN WITNESS THEREOF, LEXON INSURANCE COMPANY has caused this instrument to be signed by its President, and its Corporate Seal to be affixed this 5th day of August, 2015.



LEXON INSURANCE COMPANY

BY [Signature]
David E. Campbell
President

ACKNOWLEDGEMENT

On this 5th day of August, 2015, before me, personally came David E. Campbell to me known, who be duly sworn, did depose and say that he is the President of LEXON INSURANCE COMPANY, the corporation described in and which executed the above instrument; that he executed said instrument on behalf of the corporation by authority of his office under the By-laws of said corporation.



AMY TAYLOR
Notary Public- State of Tennessee
Davidson County
My Commission Expires 07-08-19

BY [Signature]
Amy Taylor
Notary Public

CERTIFICATE

I, the undersigned, Assistant Secretary of LEXON INSURANCE COMPANY, A Texas Insurance Company, DO HEREBY CERTIFY that the original Power of Attorney of which the forgoing is a true and correct copy, is in full force and effect and has not been revoked and the resolutions as set forth are now in force.

Signed and Seal at Mount Juliet, Tennessee this 9th Day of February, 2016.



BY [Signature]
Andrew Smith
Assistant Secretary

"WARNING: Any person who knowingly and with intent to defraud any insurance company or other person, files and application for insurance of claim containing any materially false information, or conceals for the purpose of misleading, information concerning any fact material thereto, commits a fraudulent insurance act, which is a crime and subjects such person to criminal and civil penalties."

PART IV
GENERAL CONDITIONS
TABLE OF CONTENTS

Article Number	Title	Page
1.	DEFINITIONS	GC-6
2.	PRELIMINARY MATTERS.....	GC-10
3.	CONTRACT DOCUMENTS: INTENT, CONFLICTS, AMENDING AND REUSE	GC-11
4.	AVAILABILITY OF LANDS; PHYSICAL CONDITIONS; REFERENCE POINTS	GC-13
5.	CONTRACTOR'S RESPONSIBILITIES	GC-16
6.	OTHER WORK	GC-27
7.	OWNER'S RESPONSIBILITIES	GC-28
8.	CONSULTANT'S STATUS DURING CONSTRUCTION	GC-28
9.	CHANGES IN THE WORK	GC-31
10.	CHANGE OF CONTRACT PRICE.....	GC-32
11.	CHANGE OF CONTRACT TIME	GC-39
12.	WARRANTY AND GUARANTEE; TESTS AND INSPECTIONS; CORRECTION, REMOVAL OR ACCEPTANCE OF DEFECTIVE WORK.....	GC-39
13.	PAYMENTS TO CONTRACTOR AND COMPLETION	GC-43
14.	SUSPENSION OF WORK AND TERMINATION	GC-46
15.	MISCELLANEOUS	GC-49

DETAILED TABLE OF CONTENTS OF GENERAL CONDITIONS

1. Definitions
2. Preliminary Matters
 - 2.1 Delivery of Bonds
 - 2.2 Copies of Documents
 - 2.3 Commencement of Contract Time; Notice to Proceed
 - 2.4 Starting the Project
 - 2.5 Before Starting Construction
 - 2.6 Submittal of Schedules
 - 2.7 Preconstruction Conference
 - 2.8 Finalizing Schedules
3. Contract Documents, Intent, Conflicts, Amending, and Reuse
 - 3.1 General
 - 3.2 Intent
 - 3.3 Conflicts
 - 3.4 Amending and Supplementing Contract Documents
 - 3.5 Reuse of Documents
4. Availability of Lands, Physical Conditions, Reference Points
 - 4.1 Availability of Lands
 - 4.2 Physical Conditions
 - 4.3 Physical Conditions - Underground Facilities
 - 4.4 Reference Points
5. CONTRACTOR'S Responsibilities
 - 5.1 Supervision
 - 5.2 Superintendence
 - 5.3 Labor
 - 5.4 Start-Up and Completion of Work
 - 5.5 Materials and Equipment
 - 5.6 Adjusting Progress Schedule
 - 5.7 Substitutes or "Or-Equal" Items
 - 5.8 Subcontractors, Suppliers and Others
 - 5.9 Patent Fees and Royalties
 - 5.10 Permits
 - 5.11 Laws and Regulations
 - 5.12 Taxes
 - 5.13 Use of Premises

- 5.14 Record Drawings
- 5.15 Shop Drawings and Samples
- 5.16 Continuing the Work
- 5.17 Erosion and Sediment Control

- 6. Other Work
 - 6.1 Related Work at Site
 - 6.2 Other Contractors or Utility Owners
 - 6.3 Delays Caused By Others
 - 6.4 Coordination

- 7. OWNER'S Responsibilities
 - 7.1 Communications
 - 7.2 Data and Payments
 - 7.3 Lands, Easements, and Surveys
 - 7.4 Change Orders
 - 7.5 Inspections, Tests, and Approvals
 - 7.6 Stop or Suspend Work

- 8. CONSULTANT'S Status During Construction
 - 8.1 OWNER'S Representative
 - 8.2 Visits to Site
 - 8.3 Project Representation
 - 8.4 Clarification and Interpretations
 - 8.5 Authorized Variations in Work
 - 8.6 Rejecting Defective Work
 - 8.7 Shop Drawings
 - 8.8 Change Orders
 - 8.9 Payments
 - 8.10 Determinations for Unit Prices
 - 8.11 Decisions on Disputes
 - 8.12 Limitations on CONSULTANT'S Responsibilities

- 9. Changes in the Work
 - 9.1 OWNER May Order Changes
 - 9.2 Claims
 - 9.3 Work Not in Contract Documents
 - 9.4 Change Orders
 - 9.5 Notice of Change

10. Change of Contract Price

- 10.1 Total Compensation
- 10.2 Claim for Increase or Decrease in Price
- 10.3 Value of Work
- 10.4 Cost of the Work
- 10.5 Not to Be Included in Cost of the Work
- 10.6 CONTRACTOR'S Fee
- 10.7 Itemized Cost Breakdown
- 10.8 Cash Allowance
- 10.9 Unit Price Work

11. Change of Contract Time

- 11.1 Change Order
- 11.2 Justification for Time Extension
- 11.3 Time Limits

12. Warranty and Guarantee; Tests and Inspections;
Correction, Removal or Acceptance of Defective Work

- 12.1 Warranty and Guarantee
- 12.2 Access to Work
- 12.3 Tests and Inspections
- 12.4 OWNER May Stop Work
- 12.5 Correction or Removal of Defective Work
- 12.6 One Year Correction Period
- 12.7 Acceptance of Defective work
- 12.8 Owner May Correct Defective Work

13. Payments to CONTRACTOR and Completion

- 13.1 Schedule of Values
- 13.2 Application for Progress Payments
- 13.3 CONTRACTOR'S Warranty of Title
- 13.4 Review of Application for Progress Payments
- 13.5 Partial Utilization
- 13.6 Final Inspection
- 13.7 Final Application for Payment
- 13.8 Final Payment and Acceptance
- 13.9 CONTRACTOR'S Continuing Obligation
- 13.10 Waiver of Claims

14. Suspension of Work and Termination

- 14.1 OWNER May Suspend Work
- 14.2 OWNER May Terminate
- 14.3 CONTRACTOR'S Services Terminated
- 14.4 Payment After Termination
- 14.5 CONTRACTOR May Stop or Terminate

15. Miscellaneous

- 15.1 Claims for Injury or Damage
- 15.2 Non-Discrimination in Employment
- 15.3 Temporary Street Closing or Blockage
- 15.4 Percentage of Work Performed by Prime CONTRACTOR
- 15.5 Clean-up
- 15.6 General
- 15.7 Debris Disposal

END OF SECTION

PART IV

GENERAL CONDITIONS

1. DEFINITIONS

Wherever used in these General Conditions or the other Contract Documents, the following terms have the meanings indicated which are applicable to both the singular and plural thereof.

1.1 Addenda

Written or graphic instruments issued prior to the opening of Bids which clarify, correct, or change the Bid Documents or the Contract Documents.

1.2 Agreement

The written agreement between OWNER and CONTRACTOR covering the Work to be performed; other Contract Documents are attached to the Agreement and made a part thereof as provided therein.

1.3 Application for Payment

The form accepted by CONSULTANT which is to be used by CONTRACTOR in requesting progress or final payments and which is to include such supporting documentation as is required by the Contract Documents.

1.4 Bid

The offer or proposal of the Bidder submitted on the prescribed form setting forth the prices for the Work to be performed.

1.5 Bidder

An individual, partnership, or corporation, who submit a Bid for a prime contract with the OWNER, for the Work described in the proposed Contract Documents.

1.6 Bonds

Bid, performance and payment bonds and other instruments of security.

1.7 Calendar Day

A calendar day of twenty-four hours measured from midnight to the next midnight shall constitute a day.

1.8 Change Order

A document recommended by CONSULTANT, which is signed by CONTRACTOR and OWNER and authorizes an addition, deletion or revision in the Work, or an adjustment in the Contract Price or the Contract Time, issued on or after the Effective Date of the Agreement.

- 1.9 Contract Documents**
The Advertisement for Bidders, Information for Bidders, Agreement, Addenda (which pertain to the Contract Documents), CONTRACTOR'S Bid (including documentation accompanying the Bid and any post-bid documentation submitted prior to the Notice of Award) when attached as an exhibit to the Agreement, the Bonds, these General Conditions, the Special Conditions, the Specifications and the Drawings as the same are more specifically identified in the Agreement, together with all amendments, modifications and supplements.
- 1.10 Contract Unit Price**
The monies payable by OWNER to CONTRACTOR under the Contract Documents as stated in the Agreement. Unit Prices are to be firm for the term of this Contract.
- 1.11 Contract Time**
The number of consecutive calendar days between the date of issuance of the Notice to Proceed and the contract completion date.
- 1.12 CONTRACTOR**
The person, firm or corporation with whom OWNER has entered into the Agreement.
- 1.13 Defective**
An adjective which when modifying the word Work refers to Work that is unsatisfactory, faulty or deficient, or does not conform to the Contract Documents, or does not meet the requirements of any inspection, reference standard, test or approval referred to in the Contract Documents, or has been damaged prior to CONSULTANT'S recommendation of final payment (unless responsibility for the protection thereof has been assumed by OWNER).
- 1.14 Drawings**
The drawings which show the character and scope of the Work to be performed and which have been prepared or approved by CONSULTANT and are referred to in the Contract Documents.
- 1.15 Effective Date of the Agreement**
The date indicated in the Agreement on which it becomes effective.
- 1.16 CONSULTANT**
The Lexington-Fayette Urban County Government or its authorized representative.
- 1.17 Field Order**
A documented order issued by CONSULTANT which orders minor changes in the Work, but which does not involve a change in the Contract Price or the Contract Time.

- 1.18 Giving Notice**
Whenever any provision of the Contract Documents requires the giving of written notice, it will be deemed to have been validly given if delivered in person to the individual or to a member of the firm or to an officer of the corporation for whom it is intended, or if delivered at or sent by registered or certified mail, postage prepaid, to the last business address known to the giver of the notice.
- 1.19 Laws and Regulations**
Laws, rules, regulations, ordinances, codes and/or orders.
- 1.20 Notice of Award**
The written notice by OWNER to the apparent successful bidder stating that upon compliance by the apparent successful bidder with the conditions enumerated therein, within the time specified, OWNER will sign and deliver the Agreement.
- 1.21 Notice to Proceed**
A written notice given by OWNER to CONTRACTOR fixing the date on which the Contract Time will commence to run and on which CONTRACTOR shall start to perform CONTRACTOR'S obligations under the Contract Documents.
- 1.22 OWNER**
The Lexington-Fayette Urban County Government.
- 1.23 Partial Utilization**
Placing a portion of the Work in service for the purpose for which it is intended (or related purpose) before reaching Completion for all the Work.
- 1.24 Project**
The total construction of which the Work to be provided under the Contract Documents may be the whole, or a part as indicated elsewhere in the Contract Documents.
- 1.25 Inspector**
The authorized representative who is assigned to the site or any part thereof.
- 1.26 Shop Drawings**
All drawings, diagrams, illustrations, schedules and other data which are specifically prepared by or for CONTRACTOR to illustrate some portion of the Work and all illustrations, brochures, standard schedules, performance charts, instructions, diagrams and other information prepared by a Supplier and submitted by CONTRACTOR to illustrate material or equipment for some portion of the Work.
- 1.27 Specifications**
Those portions of the Contract Documents consisting of written technical descriptions of materials, equipment, construction systems, standards and

workmanship as applied to the Work and certain administrative details applicable thereto.

- 1.28 Standard Specifications**
The "Standard Specifications for Road and Bridge Construction", Transportation Cabinet, Department of Highways, Commonwealth of Kentucky, current edition. MUTCD shall refer to the "Manual of Uniform Traffic Control Devices.
- 1.29 Subcontractor**
An individual, firm or corporation having a direct contract with CONTRACTOR or with any other Subcontractor for the performance of a part of the Work at the site.
- 1.30 Special Conditions**
The part of the Contract Documents which amends or supplements these General Conditions.
- 1.31 Supplier**
A manufacturer, fabricator, supplier, distributor, materialman or vendor.
- 1.32 Underground Facilities**
All pipelines, conduits, ducts, cables, wires, manholes, vaults, tanks, tunnels or other such facilities or attachments, and any encasements containing such facilities which have been installed underground to furnish any of the following services or materials: electricity, gases, steam, liquid petroleum products, telephone or other communications, cable television, sewage and drainage removal, traffic or other control systems or water.
- 1.33 Unit Price Work**
Not applicable
- 1.34 Work**
The entire completed construction or the various separately identifiable parts thereof required to be furnished under the Contract Documents. Work is the result of performing services, furnishing labor and furnishing and incorporating materials and equipment into the construction, all as required by the Contract Documents.
- 1.35 Time Period**
When any period of time is referred to in the Contract Documents by days, it will be computed to exclude the first and include the last day of such period. If the last day of any such period falls on a Saturday or Sunday or on a day made a legal holiday by the law of the applicable jurisdiction, such day will be omitted from the computation.

2. PRELIMINARY MATTERS

2.1 Delivery of Bonds

When the CONTRACTOR delivers the executed Agreements to OWNER, CONTRACTOR shall also deliver to OWNER, such Bonds, Insurance Certificate, and Power of Attorney as CONTRACTOR may be required to furnish.

2.2 Copies of Documents

Owner shall furnish to CONTRACTOR up to three copies (unless otherwise specified in the Special Conditions) of the Contract Documents as are reasonably necessary for the execution of the Work. Additional copies will be furnished, upon request, at the cost of reproduction.

2.3 Commencement of Contract Time; Notice to Proceed

The Contract Time will commence to run on the day specified in the Notice to Proceed.

2.4 Starting the Project

CONTRACTOR shall start to perform the Work on the date when the Contract Time commences to run, but no Work shall be done at the site prior to the date on which the Contract Time commences to run.

2.5 Before Starting Construction

Before undertaking each part of the Work, CONTRACTOR shall carefully study and compare the Contract Documents and check and verify pertinent figures shown thereon and all applicable field measurements. CONTRACTOR shall promptly report in writing to CONSULTANT any conflict, error or discrepancy which CONTRACTOR may discover and shall obtain a written interpretation or clarification from CONSULTANT before proceeding with any Work affected thereby; however, CONTRACTOR shall not be liable to OWNER or CONSULTANT for failure to report any conflict, error or discrepancy in the Contract Documents, unless CONTRACTOR had actual knowledge thereof or should reasonably have known thereof.

2.6 Submittal of Schedules

Within ten days after the effective date of the Agreement (unless otherwise specified) CONTRACTOR shall submit to CONSULTANT for review:

2.6.1 an estimated progress schedule indicating the starting and completion dates of the various stages of the Work;

2.6.2 a preliminary schedule of Shop Drawing submissions; and

2.6.3 a preliminary schedule of values for all of the Work which will include quantities and prices of items aggregating the Contract Price and will subdivide the Work into costs per labor and materials by specification

section to serve as the basis for progress payments during construction. Such prices will include an appropriate amount of overhead and profit applicable to each item of Work which will be confirmed in writing by CONTRACTOR at the time of submission. Schedule of values shall be submitted on AIA G702/703 forms, or approved equal.

2.7 Preconstruction Conference

Before CONTRACTOR starts the Work at the proposed site, a conference attended by CONTRACTOR, CONSULTANT, EEO-Affirmative Action Officer, and other appropriate parties will be held to discuss the following issues: (1) The scheduling of the Work to be completed; (2) The procedures for handling shop drawings and other submittals; (3) The processing of applications for payment; (4) The establishment of an understanding among the involved parties in regard to the proposed project; and (5) The establishment of procedures for effectively implementing the LFUCG's 10% minimum DBE goals.

2.8 Finalizing Schedules

At least ten days before submission of the first Application for Payment a conference attended by CONTRACTOR, CONSULTANT and others as appropriate will be held to finalize the schedules submitted in accordance with paragraph 2.6. The finalized progress schedule will be acceptable to CONSULTANT as providing orderly progression of the Work to completion within the Contract Time, but such acceptance will neither impose on CONSULTANT responsibility for the progress or scheduling of the Work nor relieve CONTRACTOR from full responsibility thereof. The finalized schedule of Shop Drawing submissions will be acceptable to CONSULTANT as providing a workable arrangement for processing the submissions. The finalized schedule of values will be acceptable to CONSULTANT as to form and substance.

3. CONTRACT DOCUMENTS: INTENT, CONFLICTS, AMENDING AND REUSE

3.1 General

The Contract Documents comprise the entire agreement between OWNER and CONTRACTOR concerning the Work. The Contract Documents are complementary; what is called for by one is as binding as if called for by all. The Contract Documents will be construed in accordance with the law of the place of the Project.

3.2 Intent

It is the intent of the Contract Documents to describe a functionally complete Project (or part thereof) to be constructed in accordance with the Contract Documents. Any Work, materials or equipment that may reasonably be inferred from the Contract Documents as being required to produce the intended result will be supplied whether or not specifically called for. When words which have a well-known technical or trade meaning are used to describe Work, materials or equipment such words shall be

interpreted in accordance with that meaning. Reference to standard specifications, manuals or codes of any technical society, organization or association, or to the laws or regulations of any governmental authority, whether such reference be specific or by implication, shall mean the latest standard specification, manual, code or laws or regulations in effect at the time of opening of Bids (or, on the Effective Date of the Agreement if there were no Bids), except as may be otherwise specifically stated. However, no provision of any referenced standard specification, manual or code (whether or not specifically incorporated by reference in the Contract Documents) shall be effective to change the duties and responsibilities of OWNER, CONTRACTOR or CONSULTANT, or any of their consultants, agents or employees from those set forth in the Contract Documents, nor shall it be effective to assign to CONSULTANT, or any of CONSULTANT'S consultants, agents or employees, any duty or authority to supervise or direct the furnishing or performance of the Work or any duty or authority to undertake responsibility contrary to the provisions of paragraph 8.12.3 or 8.12.4. Clarifications and interpretations of the Contract Documents shall be issued by CONSULTANT as provided in paragraph 8.4.

3.3 Conflicts

If, during the performance of the Work, CONTRACTOR finds a conflict, error or discrepancy in the Contract Documents, CONTRACTOR shall so report to CONSULTANT in writing at once and before proceeding with the Work affected thereby shall obtain a written interpretation or clarification from CONSULTANT; however, CONTRACTOR shall not be liable to OWNER or CONSULTANT for failure to report any conflict, error or discrepancy in the Contract Documents unless CONTRACTOR had actual knowledge thereof or should reasonably have known thereof.

In resolving such conflicts, errors and discrepancies, the documents shall be given precedence in the following order:

1. Agreement
2. Field and Change Orders
3. Addenda
4. Special Conditions
5. Instruction to Bidders
6. General Conditions
7. Specifications and Drawings

Figure dimension on drawings shall govern over scale dimensions and detailed Drawings shall govern over general Drawings.

3.4 Amending and Supplementing Contract Documents

The Contract Documents may be amended to provide for additions, deletions and revisions in the Work or to modify the terms and conditions thereof by means of a Change Order or a Field Order. Contract Price and Contract Time may only be changed by a Change Order.

3.5 Reuse of Documents

Neither CONTRACTOR nor any Subcontractor or Supplier or other person or organization performing or furnishing any of the Work under a direct or indirect contract with OWNER shall have or acquire any title to or ownership rights in any of the Drawings, Specifications or other documents (or copies of any thereof) prepared by or bearing the seal of CONSULTANT; and they shall not reuse any of them on extensions of the Project or any other project without written consent of OWNER and CONSULTANT and specific written verification or adaptation by CONSULTANT.

4. AVAILABILITY OF LANDS; PHYSICAL CONDITIONS, REFERENCE POINTS

4.1 Availability of Lands

OWNER shall furnish, as indicated in the Contract Documents, the lands upon which the Work is to be performed, rights-of-way and easements for access thereto, and such other lands which are designated for the use of CONTRACTOR. Easements for permanent structures or permanent changes in existing facilities will be obtained and paid for by OWNER, unless otherwise provided in the Contract Documents. If CONTRACTOR believes that any delay in OWNER'S furnishing these lands, rights-of-way or easements entitles CONTRACTOR to an extension of the Contract Time, CONTRACTOR may make a claim therefor as provided in Article 11. CONSULTANT shall determine if the claim is legitimate or not. CONTRACTOR shall provide for all additional lands and access thereto that may be required for temporary construction facilities or storage of materials and equipment.

4.2 Physical Conditions

4.2.1 Explorations and Reports

Reference is made to the Special Conditions for identification of those reports of explorations and tests of subsurface conditions at the site that have been utilized by CONSULTANT in preparation of the Contract Documents. CONTRACTOR may rely upon the accuracy of the technical data contained in such reports, but not upon non-technical data, interpretations or opinions contained therein or for the completeness thereof for CONTRACTOR'S purposes. Except as indicated in the immediately preceding sentence and in paragraph 4.2.6, CONTRACTOR shall have full responsibility with respect to subsurface conditions at the site.

4.2.2 Existing Structures

Reference is made to the Special Conditions for identification of those drawings of physical conditions in or relating to existing surface and

subsurface structures (except Underground Facilities referred to in paragraph 4.3 which are at or contiguous to the site that have been utilized by CONSULTANT in preparation of the Contract Documents. CONTRACTOR may rely upon the accuracy of the technical data contained in such drawings, but not for the completeness thereof for CONTRACTOR'S purposes. Except as indicated in the immediately preceding sentence and in paragraph 4.2.6, CONTRACTOR shall have full responsibility with respect to physical conditions in or relating to such structures.

4.2.3 Report of Differing Conditions

If CONTRACTOR believes that:

4.2.3.1 any technical data on which CONTRACTOR is entitled to rely as provided in paragraphs 4.2.1 and 4.2.2 is inaccurate, or

4.2.3.2 any physical conditions uncovered or revealed at the site differ materially from that indicated, reflected or referred to in the Contract Documents,

CONTRACTOR shall, promptly after becoming aware thereof and before performing and WORK in connection therewith (except in an emergency) notify OWNER and CONSULTANT in writing about the inaccuracy or difference.

4.2.4 CONSULTANT'S Review

CONSULTANT will promptly review the pertinent conditions, determine the necessity of obtaining additional explorations or tests with respect thereto and advise CONTRACTOR of CONSULTANT'S findings and conclusions.

4.2.5 Possible Document Change

If CONSULTANT concludes that there is a material error in the Contract Documents or that because of newly discovered conditions a change I the Contract Documents is required, a Change Order will be issued as provided in Article 10 to reflect and document the consequences of the inaccuracy or difference.

4.2.6 Possible Price and Time Adjustments

In each such case, an increase or decrease in the Contract Price or an extension or shortening of the Contract Time, or any combination thereof, will be allowable to the extent that they are attributable to any such inaccuracy or difference.

4.3 Physical Conditions-Underground Facilities

4.3.1 Shown or Indicated

The information and data shown or indicated in the Contract Documents with respect to existing Underground Facilities at or contiguous to the site is

based on information and data furnished to OWNER or CONSULTANT by the owners of such underground facilities or by others. Unless it is otherwise expressly provided in the Special Conditions:

4.3.1.1 OWNER and CONSULTANT shall not be responsible for the accuracy or completeness of any such information or data; and,

4.2.1.2 CONTRACTOR shall have full responsibility for reviewing and checking all such information and data; for locating all underground facilities shown or indicated in the Contract Documents; for coordination of the Work with the owners of such underground facilities during construction; and for the safety and protection thereof and repairing any damage thereto resulting from the Work, the cost of all of which will be considered as having been included in the Contract Price.

4.3.2 Not Shown or Indicated

If an underground facility is uncovered or revealed at or contiguous to the site which was not shown or indicated in the Contract Documents and which CONTRACTOR could not reasonably have been expected to be aware of, CONTRACTOR shall, promptly after becoming aware thereof and before performing any Work affected thereby (except in an emergency), identify the owner of such Underground Facility and give written notice thereof to that owner and to OWNER and CONSULTANT. CONSULTANT will promptly review the underground facility to determine the extent to which the Contract Documents should be modified to reflect and document the consequences of the existence of the Underground Facility, and the Contract Documents will be amended or supplemented to the extent necessary. During such time, CONTRACTOR shall be responsible for the safety and protection of such underground facility. CONTRACTOR shall be allowed an increase in the Contract Price or an extension of the Contract Time, or both, to the extent that they are attributable to the existence of any underground facility that was not shown or indicated in the Contract Documents and which CONTRACTOR could not reasonably have been expected to be aware of.

4.4 **Reference Points**

OWNER shall provide engineering surveys to establish reference points for construction which in CONSULTANT'S judgment are necessary to enable CONTRACTOR to proceed with the Work. CONTRACTOR shall be responsible for laying out the Work (unless otherwise specified), shall protect and preserve the established reference points and shall make no changes or relocations without the prior written approval of OWNER. CONTRACTOR shall report to CONSULTANT whenever any reference point is lost or destroyed or requires relocation because of necessary changes in grades or locations, and shall be responsible for the accurate replacement or relocation of such reference points by a Registered Land Surveyor.

5. CONTRACTOR'S RESPONSIBILITIES

5.1 Supervision

CONTRACTOR shall supervise and direct the Work competently and efficiently, devoting such attention thereto and applying such skills and expertise as may be necessary to perform the Work in accordance with the Contract Documents. CONTRACTOR shall assure that all CONTRACTOR personnel (including subcontractors, etc.) conduct themselves in a courteous and respectful manner toward the CONSULTANT and the general public. CONTRACTOR shall keep at the Project Site during the progress of the Work a competent project manager/superintendent and all necessary assistants, all of whom shall be satisfactory to OWNER. OWNER reserves the right to reject CONTRACTOR'S construction superintendent and project management personnel if they are unsatisfactory to OWNER and upon such rejection CONTRACTOR shall designate and provide competent successors. Failure to comply with this condition of the Contract will result in immediate suspension of the Work. Following a review by the Commissioner of Public Works, the Contract may be terminated (see GC section 14). CONTRACTOR shall be solely responsible for the means, methods, techniques, sequences and procedures of construction, but CONTRACTOR shall not be responsible for the negligence of others in the design or selection of a specific means, method, technique, sequence or procedure of construction which is indicated in and required by the Contract Documents. CONTRACTOR shall be responsible to see that the finished Work complies accurately with the Contract Documents.

5.2 Superintendence

CONTRACTOR shall keep on the Work at all times during its progress a competent resident superintendent, who shall not be replaced without written notice to OWNER and CONSULTANT except under extraordinary circumstances. The superintendent will be CONTRACTOR'S representative at the site and shall have authority to act on behalf of CONTRACTOR. All communications given to the superintendent shall be as binding as if given to CONTRACTOR.

5.3 Labor

CONTRACTOR shall provide competent, suitably qualified personnel to survey and lay out the Work and perform construction as required by the Contract Documents. CONTRACTOR shall at all times maintain good discipline and order at the site. OWNER reserves the right to require CONTRACTOR to remove from the Project any of its personnel, or subcontractor's personnel for violating LFUCG Policies, Rules or Regulations. Except in connection with the safety or protection of persons or the Work or property at the site or adjacent thereto, and except as otherwise indicated in the Contract Documents, all Work at the site shall be performed during regular working hours, and CONTRACTOR will not permit overtime work or the performance of Work on Saturday, Sunday or any legal holiday without OWNER'S written consent given after prior written notice to CONSULTANT.

5.4 Start-Up and Completion of Work

Unless otherwise specified, CONTRACTOR shall furnish and assume full responsibility for all materials, equipment, labor, transportation, construction equipment and machinery, tools, appliances, fuel, power, light, heat, telephone, water, sanitary facilities, temporary facilities and all other facilities and incidentals necessary for the furnishing, performance, testing, start-up and completion of the Work.

5.5 Materials and Equipment

All materials and equipment shall be of good quality and new, except as otherwise provided in the Contract Documents. If required by CONSULTANT, CONTRACTOR shall furnish satisfactory evidence (including reports of required tests) as to the kind and quality of materials and equipment. All materials and equipment shall be applied, installed, connected, erected, used, cleaned and conditioned in accordance with the instructions of the applicable supplier except as otherwise provided in the Contract Documents; but no provision of any such instructions will be effective to assign to CONSULTANT, or any of CONSULTANT'S consultants, agents or employees, any duty or authority to supervise or direct the furnishing or performance of the Work or any duty or authority to undertake responsibility contrary to the provisions of paragraph 8.12.3 or 8.12.4.

5.5.1 Not Clearly Specified or Indicated

In all instances where materials specified are obtainable in different sizes, weights, trade grades, qualities or finishes, etc., whose weights, trade grades, qualities or finishes, etc., are not clearly specified or indicated on the Drawings, the CONTRACTOR shall notify the CONSULTANT of all such instances at least five (5) days in advance of receiving the proposals. The CONSULTANT will then determine which size, weight, trade grade, quality, finish, etc., is required.

5.5.2 Coordination of Work

The CONTRACTOR shall see that for his own Work and for the work of each subcontractor, proper templates and patterns necessary for the coordination of the various parts of the Work are prepared. The CONTRACTOR shall furnish or require the Subcontractor to furnish such duplicates as will enable the Subcontractors to fit together and execute fully their respective portions of the Work.

5.6 Adjusting Progress Schedule

CONTRACTOR shall submit to CONSULTANT for acceptance (to the extent indicated in paragraph 2.8) adjustments in the progress schedule to reflect the impact thereon of new developments; these will conform generally to the progress schedule then in effect and additionally will comply with any provisions of the Contract Documents applicable thereto.

5.7 Substitutes or "Or-Equal" Items

5.7.1 General

Whenever materials or equipment are specified or described in the Contract Documents by using the name of a proprietary item or the name of a particular supplier, the naming of the item is intended to establish the type, function, and quality required. Unless the name is followed by words indicating that no substitution is permitted, materials or equipment of other Suppliers may be accepted by OWNER/CONSULTANT if sufficient information is submitted by CONTRACTOR to allow OWNER/CONSULTANT to determine that the material or equipment proposed is equivalent or equal to that named. The procedure for review by OWNER/CONSULTANT will include the following. Requests for review of substitute items of material and equipment will not be accepted by OWNER/CONSULTANT from anyone, other than CONTRACTOR. If CONTRACTOR wishes to furnish or use a substitute item of material or equipment, CONTRACTOR shall make written application to OWNER/CONSULTANT for acceptance thereof, certifying that the proposed substitute will perform adequately the functions and achieve the results called for by the general design, be similar and of equal substance to that specified and be suited to the same use as that specified. The application will state that the evaluation and acceptance of the proposed substitute will not prejudice CONTRACTOR'S achievement of completion on time, whether or not acceptance of the substitute for use in the Work will require a change in any of the Contract Documents (or in the provisions of any other direct contract with OWNER for work on the Project) to adapt the design to the proposed substitute and whether or not incorporation or use of the substitute in connection with the Work is subject to payment of any license fee or royalty. All variations of the proposed substitute from that specified will be identified in the application and available maintenance, repair and replacement service will be indicated. The application will also contain an itemized estimate of all costs that will result directly or indirectly from acceptance of such substitute, including costs of redesign and claims of other contractors affected by the resulting change, all of which shall be considered by OWNER/CONSULTANT in evaluating the proposed substitute. OWNER/CONSULTANT may require CONTRACTOR to furnish at CONTRACTOR'S expense additional data about the proposed substitute.

5.7.2 Substitutes

If a specific means, method, technique, sequence or procedure of construction is indicated in or required by the Contract Documents, CONTRACTOR may furnish or utilize a substitute means, method, sequence, technique or procedure of construction acceptable to OWNER/CONSULTANT, if CONTRACTOR submits sufficient information to allow OWNER/CONSULTANT to determine that the substitute proposed is equivalent to that indicated or required by the Contract Documents. The procedure for review by OWNER/CONSULTANT will be

similar to that provided in paragraph 5.7.1 as applied by OWNER/CONSULTANT.

5.7.3 OWNER/CONSULTANT'S Approval

OWNER/CONSULTANT will be allowed a reasonable time within which to evaluate each proposed substitute. OWNER/CONSULTANT will be the sole judge of acceptability, and no substitute will be ordered, installed or utilized without OWNER/CONSULTANT'S prior written acceptance which will be evidenced by either a Change Order or an approved Shop Drawing. OWNER may require CONTRACTOR to furnish at CONTRACTOR'S expense a special performance guarantee or other surety with respect to any substitute. OWNER/CONSULTANT will record time required by OWNER/CONSULTANT and OWNER/CONSULTANT'S consultants in evaluating substitutions proposed by CONTRACTOR and in making changes in the Contract Documents occasioned thereby. Whether or not OWNER/CONSULTANT accepts a proposed substitute, CONTRACTOR shall reimburse OWNER for the charges of OWNER/CONSULTANT and OWNER/CONSULTANT'S consultants for evaluating each proposed substitute.

5.8 Subcontractors, Suppliers, and Others

5.8.1 Acceptable to CONSULTANT

CONTRACTOR shall not employ any Subcontractor, Supplier or other person or organization (including those acceptable to OWNER and CONSULTANT as indicated in paragraph 5.8.2), whether initially or as a substitute, against whom OWNER or CONSULTANT may have reasonable objection. CONTRACTOR shall not be required to employ any Subcontractor, Supplier or other person or organization to furnish or perform any of the Work against whom CONTRACTOR has reasonable objection.

5.8.2 Objection After Due Investigation

If the Contract Documents require the identity of certain Subcontractors, Suppliers or other persons or organizations (including those who are to furnish the principal items of materials and equipment) to be submitted to OWNER in advance of the specified date prior to the Effective Date of the Agreement for acceptance by OWNER and CONSULTANT and if CONTRACTOR has submitted a list thereof, OWNER'S or CONSULTANT'S acceptance (either in writing or by failing to make written objection thereto by the date indicated for acceptance or objection in the bidding documents or the Contract Documents) of any such Subcontractor, Supplier or other person or organization so identified may be revoked on the basis of reasonable objection after due investigation, in which case CONTRACTOR shall submit an acceptable substitute. No acceptance by OWNER or CONSULTANT of any such Subcontractor, Supplier or other

person or organization shall constitute a waiver of any right of OWNER or CONSULTANT to reject defective Work.

5.8.3 Contractor Responsible for Acts of Subcontractors

The CONTRACTOR shall perform on the site, and with its own organization, work equivalent to at least fifty (50) percent of the total amount of Work to be performed under the Contract. This percentage may be reduced by a supplemental agreement to this Contract if, during performing the Work, the CONTRACTOR requests a reduction and the Urban County project manager determines that the reduction would be to the advantage of the Urban County Government.

The CONTRACTOR shall, at the time he submits his proposal for the Contract, notify the OWNER in writing of the names of Subcontractors proposed for the Work. He shall not employ any Subcontractor without the prior written approval of the OWNER.

CONTRACTOR shall be fully responsible to OWNER and CONSULTANT for all acts and omissions of the Subcontractors, Suppliers and other persons and organizations performing or furnishing any of the Work under a direct or indirect contract with CONTRACTOR just as CONTRACTOR is responsible for CONTRACTOR'S own acts and omissions. Nothing in the Contract Documents shall create any contractual relationship between OWNER or CONSULTANT and any such Subcontractor, Supplier or other person or organization, nor shall it create any obligation on the part of OWNER or CONSULTANT to pay or to see to the payment of any moneys due any such Subcontractor, Supplier or other person or organization except as may otherwise be required by Laws and Regulations.

5.8.4 Division of Specifications

The divisions and sections of the Specifications and the identifications of any Drawings shall not control CONTRACTOR in dividing the Work among Subcontractors or Suppliers or delineating the Work to be performed by any specific trade.

5.8.5 Agreement Between Contractor and Subcontractors

All Work performed for CONTRACTOR by a Subcontractor will be pursuant to an appropriate agreement between CONTRACTOR and the Subcontractor which specifically binds the Subcontractor to the applicable terms and conditions of the Contract Documents for the benefit of OWNER and CONSULTANT.

5.8.6 Statements and Comments by CONTRACTOR

Neither the CONTRACTOR, his employees, nor his subcontractors shall at any time make any statement or comment as to the project scope, nature, intention, design, or construction

method to any third party or parties without the explicit written consent of the OWNER.

Any third party requesting such information shall be referred to the OWNER or his representative.

Should there be any change from the original intent of the project as a result of any statement or comment by the contractor, his employees or subcontractors, contractor shall be held liable for any change in the scope, nature, design, or construction method and shall bear the full cost for the previously mentioned changes.

5.9 Patent Fees and Royalties

CONTRACTOR shall pay all license fees and royalties and assume all costs incident to the use in the performance of the Work or the incorporation in the Work of any invention, design, process, product or device which is the subject of patent rights or copyrights held by others.

5.10 Permits

Unless otherwise provided in the Special conditions, CONTRACTOR shall obtain and pay for all construction permits and licenses. OWNER shall assist CONTRACTOR, when necessary, in obtaining such permits and licenses. CONTRACTOR shall pay all governmental charges and inspection fees necessary for the prosecution of the Work, which are applicable at the time of opening of Bids, or if there are no Bids on the Effective Date of the Agreement. CONTRACTOR shall pay all charges of utility owners for connections to the Work, and OWNER shall pay all charges of such utility owners for capital costs related thereto such as plant investment fees.

5.11 Laws and Regulations

5.11.1 CONTRACTOR to Comply

CONTRACTOR shall give all notices and comply with all Laws and Regulations applicable to furnishing and performance of the Work. Except where otherwise expressly required by applicable Laws and Regulations, neither OWNER nor CONSULTANT shall be responsible for monitoring CONTRACTOR'S compliance with any Laws and Regulations.

5.11.2 Specifications and Drawings at Variance

If CONTRACTOR observes that the Specifications or Drawings are at variance with any Laws or Regulations, CONTRACTOR shall give CONSULTANT prompt written notice thereof, and any necessary changes will be authorized by one of the methods indicated in paragraph 3.4. If CONTRACTOR performs any Work knowing or having reason to know that it is contrary to such Laws, or Regulations, and without such notice to CONSULTANT, CONTRACTOR shall bear all costs arising therefrom; however, it shall not be CONTRACTOR'S primary responsibility to make certain that the Specifications and Drawings are in accordance with such Laws and Regulations.

Any party, firm or individual submitting a proposal pursuant to invitation must have paid all taxes owed to the Lexington-Fayette Urban County Government at the time the proposal is submitted, and must maintain a "current" status in regard to those taxes throughout the Contract. If applicable, business must be licensed in Fayette County.

5.12 Taxes

CONTRACTOR shall pay all sales, consumer, use and other similar taxes required to be paid by CONTRACTOR in accordance with the Laws and Regulations of the place of the Project which are applicable during the performance of the Work. Any party, firm or individual submitting a proposal pursuant to invitation must have paid all taxes owed to the Lexington-Fayette Urban County Government at the time the proposal is submitted, and must maintain a "current" status in regard to those taxes throughout the Contract. If applicable, business must be licensed in Fayette County.

5.13 Use of Premises

5.13.1 Project Site

CONTRACTOR shall confine construction equipment, the storage of materials and equipment and the operations of workers to the staging areas or work site areas identified in and permitted by the Contract Documents and other land and areas permitted by Laws and Regulations, rights-of-way, permits and easements, and shall not unreasonably encumber the premises with construction equipment or other materials or equipment. CONTRACTOR shall assume full responsibility for any damage to any such

land or area, or to the owner or occupant thereof or of any land or areas contiguous thereto, resulting from the performance of the Work. Should any claim be made against OWNER or CONSULTANT by any such owner or occupant because of the performance of the Work, CONTRACTOR shall promptly attempt to settle with such other party by agreement or otherwise resolve the claim by arbitration or at law. CONTRACTOR shall, to the fullest extent permitted by Laws and Regulations, indemnify and hold OWNER and CONSULTANT harmless from and against all claims, damages, losses and expenses (including, but not limited to, fees of engineers, architects, attorneys and other professionals and court and arbitration costs) arising directly, indirectly or consequentially out of any action, legal or equitable, brought by any such other party against OWNER or CONSULTANT to the extent based on a claim arising out of CONTRACTOR'S performance of the Work.

5.13.2 Clean UP

During the progress of the Work, CONTRACTOR shall keep the premises free from accumulations of waste materials, rubbish and other debris resulting from the Work. At the completion of the Work, CONTRACTOR shall remove all waste materials, rubbish and debris from and about the premises as well as all tools, appliances, construction equipment and machinery, and surplus materials, and shall leave the site clean and ready for occupancy by OWNER. CONTRACTOR shall restore to original condition all property not designated for alteration by the Contract Documents.

5.13.1 Loading of Structures

CONTRACTOR shall not load nor permit any part of any structure to be loaded in any manner that will endanger the structure, nor shall CONTRACTOR subject any part of the Work or adjacent property to stresses or pressures that will endanger it.

5.14 Record Drawings

CONTRACTOR shall maintain in a safe place at the site one record copy of all Drawings, Specifications, Addenda, Change Orders, Field Orders and written interpretations and clarifications (issued pursuant to paragraph 9.4) in good order and annotated to show all changes made during construction. These record documents together with all approved samples and a counterpart of all approved Shop Drawings will be available to CONSULTANT for reference. Upon completion of the Work, these record documents, samples and Shop Drawings will be delivered to CONSULTANT for OWNER.

5.15 Shop Drawings and Samples

5.15.1 Shop Drawing Submittals

After checking and verifying all field measurements and after complying

with applicable procedures specified, CONTRACTOR shall submit to CONSULTANT for review and approval in accordance with the accepted schedule of Shop Drawing submissions (see paragraph 2.8), or for other appropriate action if so indicated in the Special Conditions, five copies (unless otherwise specified) of all Shop Drawings, which will bear a stamp or specific written indication that CONTRACTOR has satisfied CONTRACTOR'S responsibilities under the Contract Documents with respect to the review of the submission. All submissions will be identified as CONSULTANT may require. The data shown on the Shop Drawings will be complete with respect to quantities, dimensions, specified performance and design criteria, materials and similar data to enable CONSULTANT to review the information as required.

5.15.2 Sample Submittals

CONTRACTOR shall also submit to CONSULTANT for review and approval with such promptness as to cause no delay in Work, all samples required by the Contract Documents. All samples will have been checked by and accompanied by a specific written indication that CONTRACTOR has satisfied CONTRACTOR'S responsibilities under the Contract Documents with respect to the review of the submission and will be identified clearly as to material, Supplier, pertinent data such as catalog numbers and the use for which intended.

5.15.3 Review by CONTRACTOR

Before submission of each Shop Drawing or sample CONTRACTOR shall have determined and verified all quantities, dimensions, specified performance criteria, installation requirements, materials, catalog numbers and similar data with respect thereto and reviewed or coordinated each Shop Drawing or sample with other Shop Drawings and samples and with the requirements of the Work and the Contract Documents.

5.15.4 Notice of Variation

At the time of each submission, CONTRACTOR shall give CONSULTANT specific written notice of each variation that the Shop Drawings or samples may have from the requirements of the Contract Documents, and, in addition, shall cause a specific notation to be made on each Shop Drawing submitted to CONSULTANT for review and approval of each such variation.

5.15.5 CONSULTANT'S Approval

CONSULTANT will review and approve with reasonable promptness Shop Drawings and samples, but CONSULTANT'S review and approval will be only for conformance with the design concept of the Project and for compliance with the information given in the Contract Documents and shall not extend to means, methods, techniques, sequences or procedures of construction (except where a specific means, method, technique, sequence or

procedure of construction is indicated in or required by the Contract Documents) or to safety precautions or programs incident thereto. The review and approval of a separate item as such will not indicate approval of the assembly in which the item functions. CONTRACTOR shall make corrections required by CONSULTANT, and shall return the required number of corrected copies of Shop Drawings and submit, as required, new samples for review and approval. CONTRACTOR shall direct specific attention in writing to revisions other than the corrections called for by CONSULTANT on previous submittals.

5.15.6 Responsibility for Errors and Omissions

CONSULTANT'S review and approval of Shop Drawings or samples shall not relieve CONTRACTOR from responsibility for any variation from the requirements of the Contract Documents unless CONTRACTOR has in writing called CONSULTANT'S attention to each such variation at the time of submission as required by paragraph 5.15.4 and CONSULTANT has given written approval of each such variation by a specific written notation thereof incorporated in or accompanying the Shop Drawing or sample approval; nor will any approval by CONSULTANT relieve CONTRACTOR from responsibility for errors or omissions in the Shop Drawings or from responsibility for having complied with the provisions of paragraph 5.15.3.

5.15.7 Cost of Related Work

Where a Shop or sample is required by the Specifications, any related Work performed prior to CONSULTANT'S review and approval of the pertinent submission will be the sole expense and responsibility of CONTRACTOR.

5.16 Continuing the Work

CONTRACTOR shall carry on the Work and adhere to the progress schedule during all disputes or disagreements with OWNER. No Work shall be delayed or postponed pending resolutions of any disputes or disagreements, except as permitted by paragraph 14.5 or as CONTRACTOR and OWNER may otherwise agree in writing.

5.17 Erosion and Sediment Control

5.17.1 General Environmental Requirements

The CONTRACTOR and Subcontractors performing work on projects on behalf of the OWNER shall comply with all applicable federal, state, and local environmental regulations and all requirements and conditions set forth in "special" permits including but not limited to Corp of Engineers 404 permits, 401 Water Quality Certifications, Stream Crossing and Floodplain Encroachment Permits.

Any fines or penalties resulting from the failure to comply with the terms of the federal, state or local permits or perform necessary corrective action are solely the obligation of the CONTRACTOR.

5.17.2 Stormwater Pollution Prevention

A. The CONTRACTOR shall exercise due care to prevent or minimize any damage to any stream or wetland from pollution by debris, sediment or other material. The operation of equipment and/or materials in a jurisdictional wetland is expressly prohibited. Water that has been used for washing or processing, or that contains oils, sediments or other pollutants shall not be discharged from the job site. Such waters shall be collected and properly disposed of by the CONTRACTOR in accordance with applicable local, state and federal law.

B. The CONTRACTOR is solely responsible for securing all required state and local permits associated with stormwater discharges from the project including, but not necessarily limited to the KY Notice of Intent to Disturb (NOI) for Coverage of Storm Water Discharges Associated with Construction Activities under the KPDES Storm Water General Permit KYR100000 and the LFUCG, Land Disturbance Permit. Permit application preparation and all required documentation are the responsibility of the CONTRACTOR. The CONTRACTOR is solely responsible for maintaining compliance with the stormwater pollution prevention plan or erosion and sediment control plan and ensuring the following:

- a. That the Stormwater Pollution Prevention Plan (SWPPP) or erosion control plan is current and available for review on site;
- b. That any and all stormwater inspection reports required by the permit are conducted by qualified personnel and are available for review onsite; and
- c. That all best management practices (BMPs) are adequately maintained and effective at controlling erosion and preventing sediment from leaving the site.

C. The CONTRACTOR shall provide the necessary equipment and personnel to perform any and all emergency measures that may be required to contain any spillage or leakage and to remove materials, soils or liquids that become contaminated. The collected spill material shall be properly disposed at the CONTRACTOR's expense.

D. Upon completion of the work and with the concurrence of the OWNER, the CONTRACTOR must file a Notice of Termination (NOT) of Coverage Under the KPDES General Permit for Storm Water Discharges Associated with Construction Activity with the appropriate local and state authorities.

E. Any fines or penalties resulting from the failure to comply with the terms of the state or local stormwater permits or perform necessary corrective action are solely the obligation of the CONTRACTOR.

6. OTHER WORK

6.1 Related Work at Site

OWNER may perform other work related to the Project at the site by OWNER'S own forces, have other work performed by utility owners or let other direct contracts therefor which shall contain General Conditions similar to these. If the fact that such other work is to be performed was not noted in the Contract Documents, written notice thereof will be given to CONTRACTOR prior to starting any such other work; and, if such performance will involve additional expense to CONTRACTOR or requires additional time, a Change Order to the Contract will be negotiated.

6.2 Other Contractors or Utility Owners

CONTRACTOR shall afford each utility owner and other contractor who is a party to such a direct contract (or OWNER, if OWNER is performing the additional work with OWNER'S employees) proper and safe access to the site and a reasonable opportunity for the introduction and storage of materials and equipment and the execution of such work, and shall properly connect and coordinate the Work with theirs. CONTRACTOR shall do all cutting, fitting and patching of the Work that may be required to make its several parts come together properly and integrate with such other work. CONTRACTOR shall not endanger any work of others by cutting, excavating or otherwise altering their work and will only cut or alter their work with the written consent of CONSULTANT and the others whose work will be affected. The duties and responsibilities of CONTRACTOR under this paragraph are for the benefit of such utility owners and other contractors to the extent that there are comparable provisions for the benefit of CONTRACTOR in said direct contracts between OWNER and such utility owners and other contractors.

6.3 Delays Caused by Others

If any part of CONTRACTOR'S Work depends for proper execution or results upon the work of any such other contractor or utility owner (or OWNER), CONTRACTOR shall inspect and promptly report to CONSULTANT in writing any delays, defects or deficiencies in such work that render it unavailable or unsuitable for such proper execution and results. CONTRACTOR'S failure so to report will constitute an acceptance of the other work as fit and proper for integration with CONTRACTOR'S Work except for latent or non-apparent defects and deficiencies in the other work.

6.4 Coordination

If OWNER contracts with others for the performance of other work on the Project at the site, the person or organization who will have authority and responsibility for coordination of the activities among the various prime contractors will be identified in the Special Conditions, and the specific matters to be covered by such authority and

responsibility will be itemized, and the extent of such authority and responsibilities will be provided, in the Special Conditions.

7. OWNER'S RESPONSIBILITIES

7.1 Communications

OWNER shall issue all communications to CONTRACTOR through CONSULTANT.

7.2 Data and Payments

OWNER shall furnish the data required of OWNER under the Contract Documents promptly after they are due.

7.3 Lands, Easements, and Surveys

OWNER'S duties in respect of providing lands and easements and providing engineering surveys to establish reference points are set forth in paragraphs 4.1 and 4.4. Paragraph 4.2 refers to OWNER'S identifying and making available to CONTRACTOR copies of reports of explorations and tests of subsurface conditions at the site and in existing structures which have been utilized by CONSULTANT in preparing the Drawings and Specifications.

7.4 Change Orders

OWNER is obligated to execute Change Orders as indicated in paragraph 9.4.

7.5 Inspections, Tests and Approvals

OWNER'S responsibility in respect to certain inspections, tests and approvals is set forth in paragraph 13.3.

7.6 Stop or Suspend Work

In connection with OWNER'S right to stop Work or suspend Work, see paragraph 12.4 and 14.1 Paragraph 14.2 deals with OWNER'S rights to terminate services of CONTRACTOR under certain circumstances.

8. CONSULTANT'S STATUS DURING CONSTRUCTION

8.1 OWNER'S Representative

CONSULTANT will be OWNER'S representative during the construction period. The duties and responsibilities and the limitations of authority of CONSULTANT as OWNER'S representative during construction are set forth in the Contract Documents and shall not be extended without written consent of OWNER and CONSULTANT.

8.2 Visits to Site

CONSULTANT will make visits to the site at intervals appropriate to the various stages of construction to observe the progress and quality of the executed Work and to determine, in general, if the Work is proceeding in accordance with the Contract Documents. CONSULTANT will not be required to make exhaustive or

continuous on-site inspections to check the quality or quantity of the Work. CONSULTANT'S efforts will be directed toward providing for OWNER a greater degree of confidence that the completed Work will conform to the Contract Documents. On the basis of such visits and on-site observations, CONSULTANT will keep OWNER informed of the progress of the Work and will endeavor to guard OWNER against defects and deficiencies in the Work.

- 8.3 Project Representation**
CONSULTANT will provide an Inspector to assist CONSULTANT in observing the performance of the Work. If OWNER designates another agent to represent OWNER at the site who is not CONSULTANT'S agent or employee, the duties, responsibilities and limitations of authority of such other person will be as provided in the Special Conditions.
- 8.4 Clarifications and Interpretations**
CONSULTANT will issue with reasonable promptness such written clarifications or interpretations of the requirements of the Contract Documents (in the form of Drawings or otherwise) as CONSULTANT may determine necessary, which shall be consistent with or reasonably inferable from the overall intent of the Contract Documents.
- 8.5 Authorized Variations in Work**
CONSULTANT may authorize minor variations in the Work from the requirements of the Contract Documents which do not involve an adjustment in the Contract Price or the Contract Time and are consistent with the overall intent of the Contract Documents. These may be accomplished by a Field Order.
- 8.6 Rejecting Defective Work**
CONSULTANT will have authority to disapprove or reject Work which CONSULTANT believes to be defective, and will also have authority to require special inspection or testing of the Work as provided in paragraph 12.3, whether or not the Work is fabricated, installed or completed.
- 8.7 Shop Drawings**
In connection with CONSULTANT'S responsibility for Shop Drawings and samples, see paragraphs 5.15.1 through 5.16 inclusive.
- 8.8 Change Orders**
In connection with CONSULTANT'S responsibilities as to Change Orders, see Articles 10, 11 and 12.
- 8.9 Payments**
In connection with CONSULTANT'S responsibilities with respect to Applications for Payment, etc., see Article 13.
- 8.10 Determinations for Unit Prices**

CONSULTANT will determine the actual quantities and classifications of Unit Price Work performed by CONTRACTOR.

CONSULTANT will review with CONTRACTOR CONSULTANT'S preliminary determinations on such matters before rendering a written decision thereon (by recommendation of an Application for Payment or otherwise).

8.11 Decision on Disputes

CONSULTANT will be the initial interpreter of the requirements of the Contract Documents and judge of the acceptability of the Work thereunder. Claims, disputes and other matters relating to the acceptability of the Work or the interpretation of the requirements of the Contract Documents pertaining to the performance and furnishing of the Work and claims under Articles 10 and 11 in respect of changes in the Contract Price or Contract Time will be referred initially to CONSULTANT in writing with a request for a formal decision in accordance with this paragraph, which CONSULTANT will render in writing within a reasonable time. Written notice of each such claim, dispute and other matter will be delivered to CONSULTANT promptly (but in no event later than thirty days) after the occurrence of the event giving rise thereto, and written supporting data will be submitted to CONSULTANT within sixty days after such occurrence unless CONSULTANT allows an additional period of time to ascertain more accurate data in support of the claim.

8.12 Limitations on CONSULTANT's Responsibilities

8.12.1 CONTRACTOR, Supplier, or Surety

Neither CONSULTANT'S authority to act under this Article 8 or elsewhere in the Contract Documents nor any decision made by CONSULTANT in good faith either to exercise or not exercise such authority shall give rise to any duty or responsibility of CONSULTANT to CONTRACTOR, any Subcontractor, any Supplier, or any other person or organization performing any of the Work, or to any surety for any of them.

8.12.2 To Evaluate the Work

Whenever in the Contract Documents the terms "as ordered", "as directed", "as required", "as allowed", "as approved" or terms of like effect or import are used, or the adjectives "reasonable", "suitable", "acceptable", "proper", or "satisfactory" or adjectives or like "effect" or "import" are used to describe a requirement, direction, review or judgment of CONSULTANT as to the Work, it is intended that such requirement, direction, review or judgment will be solely to evaluate the Work for compliance with the Contract Documents (unless there is a specific statement indicating otherwise). The use of any such term or adjective shall not be effective to assign CONSULTANT any duty or authority to supervise or direct the furnishing or performance of the Work or any duty or authority to undertake responsibility contrary to the provisions of paragraph 8.12.3 or 8.12.4.

8.12.3 CONTRACTOR'S Means, Methods, Etc.

CONSULTANT will not be responsible for CONTRACTOR'S means, methods, techniques, sequences or procedures of construction, or the safety precautions and programs incident thereto, and CONSULTANT will not be responsible for CONTRACTOR'S failure to perform or furnish the Work in accordance with the Contract Documents.

8.12.4 Acts of Omissions of CONTRACTOR

CONSULTANT will not be responsible for the acts or omissions of CONTRACTOR or of any Subcontractor, any Supplier, or of any other person or organization performing or furnishing any of the Work.

9. **CHANGES IN THE WORK**

9.1 **OWNER May Order Change**

Without invalidating the Agreement and without notice to any surety, OWNER may, at any time or from time to time, order additions, deletions or revisions in the Work; these will be authorized by a Change Order. Upon receipt of such notice, CONTRACTOR shall promptly proceed with the Work involved which will be performed under the applicable conditions of the Contract Documents (except as otherwise specifically provided).

9.2 **Claims**

Claims for an increase or decrease in the Contract Price or an extension or shortening of the Contract Time that should be allowed as a result of a Change Order will be settled as provided for in Article 10 or Article 11.

9.3 **Work Not in Contract Documents**

CONTRACTOR shall not be entitled to an increase in the Contract Price or an extension of the Contract Time with respect to any Work performed that is not required by the Contract Documents as amended, modified and supplemented as provided in paragraph 3.4, except in the case of an emergency and except in the case of uncovering Work as provided in paragraph 12.3.4.

9.4 **Change Orders**

OWNER and CONTRACTOR shall execute appropriate Change Orders covering:

9.4.1 changes in the Work which are ordered by OWNER pursuant to paragraph 9.1, are required because of acceptance of defective Work under paragraph 12.7 or corrective defective Work under paragraph 12.8, or are agreed to by the parties;

9.4.2 changes in the Contract Price or Contract Time which are agreed to by the parties; and

9.4.3 changes in the Contract Price or Contract Time which embody the substance of any written decision rendered by CONSULTANT pursuant to paragraph 8.11; provided that, in lieu of executing any such Change Order, an appeal may be taken from any such decision in accordance with the provisions of the Contract Documents and applicable Laws and REGULATIONS, but during any such appeal, CONTRACTOR shall carry on the Work and adhere to the progress schedule as provided in paragraph 5.16.

9.5 Notice of Change

If notice of any change affecting the general scope of the Work or the provisions of the Contract Documents (including, but not limited to, Contract Price or Contract Time) is required by the provisions of any Bond to be given to a surety, the giving of any such notice will be CONTRACTOR'S responsibility, and the amount of each applicable Bond will be adjusted accordingly.

10. CHANGE OF CONTRACT PRICE

10.1 Total Compensation

The Contract Price constitutes the total compensation (subject to authorized adjustments) payable to CONTRACTOR for performing the Work. All duties, responsibilities and obligations assigned to or undertaken by CONTRACTOR shall be at his expense without change in the Contract Price.

10.2 Claim for Increase or Decrease in Price

The Contract Price may only be changed by a Change Order. Any claim for an increase or decrease in the Contract Price shall be based on written notice delivered by the CONTRACTOR to the CONSULTANT promptly (but in no event later than thirty days) after the occurrence of the event giving rise to the claim and stating the general nature of the claim. Notice of the amount of the claim with supporting data shall be delivered within sixty days after such occurrence (unless CONSULTANT allows an additional period of time to ascertain more accurate data in support of the claim) and shall be accompanied by CONTRACTOR'S written statement that the amount claimed covers all known amounts (direct, indirect, and consequential) to which the CONTRACTOR is entitled as a result of the occurrence of said event.

10.3 Value of Work

The value of any Work covered by a Change Order or of any claim for an increase or decrease in the Contract Price shall be determined in one of the following ways:

10.3.1 Unit Prices

Where the Work involved is covered by unit prices contained in the Contract Documents, by application of unit prices to the quantities of the items involved (subject to the provisions of paragraphs 10.9.1. through 10.9.3, inclusive).

10.3.2 Lump Sum

By mutual acceptance of a lump sum (which may include an allowance for overhead and profit not necessarily in accordance with paragraph 10.6.2.1).

10.3.3 Cost Plus Fee

On the basis of the Cost of the Work (determined as provided in paragraphs 10.4 and 10.5) plus a CONTRACTOR'S fee for overhead and profit (determined as provided in paragraphs 10.6 and 10.7).

10.4 Cost of the Work

The term Cost of the Work means the sum of all costs necessarily incurred and paid by CONTRACTOR in the proper performance of the Work. Except as otherwise may be agreed to in writing by OWNER, such costs shall be in amounts no higher than those prevailing in the locality of the Project; shall include only the following items; and shall not include any of the costs itemized in paragraph 10.5:

10.4.1 Payroll Costs

Payroll costs for employees in the direct employ of CONTRACTOR in the performance of the Work under schedules of job classifications agreed upon by OWNER and CONTRACTOR. Payroll costs for employees not employed full time on the Work shall be apportioned on the basis of their time spent on the Work. Payroll costs shall include, but not be limited to, salaries and wages plus the cost of fringe benefits which shall include social security contributions, unemployment, excise and payroll taxes, workers' or workmen's compensation, health and retirement benefits, bonuses, sick leave, vacation and holiday pay applicable thereto. Such employees shall include superintendents and foremen at the site. The expenses of performing Work after regular working hours, on Saturday, Sunday or legal holidays, shall be included in the above to the extent authorized by OWNER.

10.4.2 Materials and Equipment Costs

Cost of all materials and equipment furnished and incorporated in the Work, including costs of transportation and storage thereof, and Suppliers' field services required in connection therewith. All cash discounts shall accrue to CONTRACTOR unless OWNER deposits funds with CONTRACTOR with which to make payments, in which case the cash discounts shall accrue to OWNER. All trade discounts, rebates and refunds and all returns from sale of surplus materials and equipment shall accrue to OWNER, and CONTRACTOR shall make provisions so that they may be obtained.

10.4.3 Subcontractor Costs

Payments made by CONTRACTOR to the Subcontractors for Work performed by Subcontractors. If required by OWNER, CONTRACTOR shall obtain competitive bids from Subcontractors acceptable to CONTRACTOR and shall deliver such bids to OWNER who will then determine, with the advice of CONSULTANT, which bids will be accepted. If a subcontract provides that the Subcontractor is to be paid on the basis of Cost of the Work Plus a Fee, the Subcontractor's Cost of the Work shall be determined in the same manner as CONTRACTOR'S Cost of the Work. All subcontracts shall be subject to the other provisions of the Contract Documents insofar as applicable.

10.4.4 Special Consultant Costs

Costs of special consultants (including but not limited to engineers, architects, testing laboratories, surveyors, attorneys and accountants) employed for services specifically related to the Work.

10.4.5 Supplemental Costs

10.4.5.1 The proportion of necessary transportation, travel and subsistence expenses of CONTRACTOR'S employees incurred in discharge of duties connected with the Work.

10.4.5.2 Cost, including transportation and maintenance, of all materials, supplies, equipment, machinery, appliances, office and temporary facilities at the site and hand tools not owned by the workers, which are consumed in the performance of the Work, and cost less market value of such items used but not consumed which remain the property of CONTRACTOR.

10.4.5.3 Rentals of all construction equipment and machinery and the parts thereof whether rented from CONTRACTOR or others in accordance with rental agreements approved by OWNER with the advice of CONSULTANT, and the costs of transportation, loading, unloading, installation, dismantling and removal shall be in accordance with terms of said rental agreements. The rental of any such equipment, machinery or parts shall cease when the use thereof is no longer necessary for the Work.

10.4.5.4 Sales, consumer, use or similar taxes related to the Work, and for which CONTRACTOR is liable, imposed by Laws and Regulations.

10.4.5.5 Deposits lost for causes other than negligence of CONTRACTOR, any Subcontractor or anyone directly or indirectly employed by any of them or for whose acts any of them may be liable, and royalty payments and fees for permits and licenses.

10.4.5.6 Losses and damages (and related expenses), not compensated by insurance or otherwise, to the Work or otherwise sustained by CONTRACTOR in connection with the performance and furnishing of the Work (except losses and damages within the deductible amounts of property insurance established by OWNER), provided they have resulted from causes other than the negligence of CONTRACTOR, any Subcontractor, or anyone directly or indirectly employed by any of them or for whose acts any of them may be liable. Such losses shall include settlements made with the written consent and approval of OWNER. No such losses, damages and expenses shall be included in the Cost of the Work for the purpose of determining CONTRACTOR'S fee. If, however, any such loss or damage requires reconstruction and CONTRACTOR is placed in charge thereof, CONTRACTOR shall be paid a fee proportionate to that stated in paragraph 10.6.2 for services.

10.4.5.7 The cost of utilities, fuel and sanitary facilities at the site.

10.4.5.8 Minor expenses such as telegrams, long distance telephone calls, telephone service at the site, expressage and similar petty cash items in connection with the Work.

10.4.5.9 Cost of premiums for additional Bonds and insurance required because of changes in the Work and premiums for property insurance coverage within the limits of the deductible amounts established by OWNER.

10.5 Not to Be Included in Cost of the Work

The term Cost of the Work shall not include any of the following:

10.5.1 Costs of Officers and Executives

Payroll costs and other compensation of CONTRACTOR'S officers, executives, principals (of partnership and sole proprietorships), general managers, engineers, architects, estimators, attorneys, auditors, accountants, purchasing and contracting agents, expeditors, timekeepers, clerks and other personnel employed by CONTRACTOR whether at the site or in CONTRACTOR'S principal or a branch office for general administration of

the Work and not specifically included in the agreed upon schedule of job classifications referred to in paragraph 10.4.1 or specifically covered by paragraph 10.4.4 - all of which are to be considered administrative costs covered by the CONTRACTOR'S fee.

10.5.2 Principal Office

Expenses of CONTRACTOR'S principal and branch offices other than CONTRACTOR'S office at the site.

10.5.3 Capital Expense

Any part of CONTRACTOR'S capital expenses, including interest on CONTRACTOR'S capital employed for the Work and charges against CONTRACTOR for delinquent payments.

10.5.4 Bonds and Insurance

Cost of premiums for all Bonds and for all insurance whether or not CONTRACTOR is required by the Contract Documents to purchase and maintain the same (except for the cost of premiums covered by subparagraph 10.4.5.9 above).

10.5.5 Costs Due to Negligence

Costs due to the negligence of CONTRACTOR, any Subcontractor, or anyone directly or indirectly employed by any of them or for whose acts any of them may be liable, including but not limited to, the correction of defective Work, disposal of materials or equipment wrongly supplied and making good any damage to property.

10.5.6 Other Costs

Other overhead or general expense costs of any kind and the costs of any item not specifically and expressly included in paragraph 10.4.

10.6 Contractor's Fee

The CONTRACTOR'S Fee allowed to CONTRACTOR for overhead and profit shall be determined as follows:

10.6.1 a mutually acceptable fixed fee; or if none can be agreed upon,

10.6.2 a fee based on the following percentages of the various portions of the Cost of the Work:

10.6.2.1 for costs incurred under paragraphs 10.4.1 and 10.4.2, the CONTRACTOR'S fee shall be fifteen percent;

10.6.2.2 for costs incurred under paragraph 10.4.3, the CONTRACTOR'S fee shall be five percent; and if a subcontract is on the basis of Cost of the Work Plus a fee, the maximum allowable to CONTRACTOR on account of overhead and profit of all Subcontractors shall be fifteen percent;

10.6.2.3 no fee shall be payable on the basis of costs itemized under paragraphs 10.4.4, 10.4.5 and 10.5;

10.6.2.4 the amount of credit to be allowed by CONTRACTOR to OWNER for any such change which results in a net decrease in cost will be the amount of the actual net decrease plus a deduction in CONTRACTOR'S Fee by an amount equal to ten percent of the net decrease; and

10.6.2.5 when both additions and credits are involved in any one change, the adjustment in CONTRACTOR'S fee shall be computed on the basis of the net change in accordance with paragraphs 10.6.2.1 through 10.6.2.4, inclusive.

10.7 Itemized Cost Breakdown

Whenever the cost of any Work is to be determined pursuant to paragraph 10.4 or 10.5, CONTRACTOR will submit in form acceptable to CONSULTANT an itemized cost breakdown together with supporting data.

10.8 Cash Allowances

It is understood that CONTRACTOR has included in the Contract Price all allowances so named in the Contract Documents and shall cause the Work so covered to be done by such Subcontractors or Suppliers and for such sums within the limit of the allowances as may be acceptable to CONSULTANT, CONTRACTOR agrees that:

10.8.1 Materials and Equipment

The allowances include the cost to CONTRACTOR (less any applicable trade discounts) of materials and equipment required by the allowances to be delivered at the site, and all applicable taxes; and

10.8.2 Other Costs

CONTRACTOR'S costs for unloading and handling on the site, labor, installation costs, overhead, profit and other expenses contemplated for the allowances have been included in the Contract Price and not in the allowances. No demand for additional payment on account of any thereof will be valid.

10.8.3 Change Order

Prior to final payment, an appropriate Change Order will be issued as recommended by CONSULTANT to reflect actual amounts due CONTRACTOR on account of Work covered by allowances, and the Contract Price shall be correspondingly adjusted.

10.9 Unit Price Work

10.9.1 General

Where the Contract Documents provide that all or part of the Work is to be Unit Price Work, initially the Contract Price will be deemed to include for all Unit Price Work an amount equal to the sum of the established unit prices for each separately identified item of Unit Price Work times the estimated quantity of each item as indicated in the Agreement. The estimated quantities of items of Unit Price Work are not guaranteed and are solely for the purpose of comparison of Bids and determining an initial Contract Price. Determinations of the actual quantities and classifications of Unit Price Work performed by CONTRACTOR will be made by CONSULTANT in accordance with Paragraph 8.10.

10.9.2 Overhead and Profit

Each unit price will be deemed to include an amount considered by CONTRACTOR to be adequate to cover CONTRACTOR'S overhead and profit for each separately identified item.

10.9.3 Claim for Increase in Unit Price

Where the quantity of any item of Unit Price Work performed by CONTRACTOR differs materially and significantly from the estimated quantity of such item indicated in the Agreement and there is no corresponding adjustment with respect to any other item of Work and if CONTRACTOR believes that CONTRACTOR has incurred additional expense as a result thereof, CONTRACTOR may make a claim for an increase in the Contract Price in accordance with Article 10.

11. CHANGE OF CONTRACT TIME

11.1 Change Order

The Contract Time may only be changed by a Change Order. Any claim for an extension or shortening of the Contract Time shall be based on written notice delivered to CONSULTANT promptly (but in no event later than thirty days) after the occurrence of the event giving rise to the claim and stating the general nature of the claim. Notice of the extent of the claim with supporting data shall be delivered within sixty days after such occurrence (unless CONSULTANT allows an additional period of time to ascertain more accurate data in support of the claim) and shall be accompanied by the claimant's written statement that the adjustment claimed is the entire adjustment to which the claimant has reason to believe it is entitled as a result of the occurrence of said event. All claims for adjustment in the Contract Time shall be determined by CONSULTANT in accordance with paragraph 8.11. No claim for an adjustment in the Contract Time will be valid if not submitted in accordance with the requirements of this paragraph 11.1.

11.2 Justification for Time Extensions

The Contract Time will be extended in an amount equal to time lost due to delays beyond the control of CONTRACTOR if a claim is made therefore as provided in paragraph 11.1. Such delays shall include, but not be limited to, acts or neglect by OWNER or others performing additional work as contemplated by Article 6, or to fires, floods, labor disputes, epidemics, abnormal weather conditions or acts of God.

11.3 Time Limits

All time limits stated in the Contract Documents are of the essence of the Agreement. The provisions of this Article 11 shall not exclude recovery for damages (including but not limited to fees and charges of engineers, architects, attorneys and other professionals and court costs) for delay by either party.

12. WARRANTY AND GUARANTEE; TESTS AND INSPECTIONS; CORRECTION, REMOVAL OR ACCEPTANCE OF DEFECTIVE WORK

12.1 Warranty and Guarantee

CONTRACTOR warrants and guarantees to OWNER and CONSULTANT that all Work will be in accordance with the Contract Documents and will not be defective. All defective Work, whether or not in place, may be rejected, corrected or accepted as provided in this Article 12.

12.2 Access to Work

CONSULTANT and CONSULTANT'S representatives, other representatives of OWNER, testing agencies and governmental agencies with jurisdictional interests will have access to the Work at reasonable times for their observation, inspecting and testing. CONTRACTOR shall provide proper and safe conditions for such access.

12.3 Tests and Inspections

12.3.1 Timely Notice

CONTRACTOR shall give CONSULTANT timely notice of readiness of the Work for all required inspections, tests or approvals.

12.3.2 Requirements and Responsibilities

The CONSULTANT may require such inspection and testing during the course of the Work as he/she deems necessary to ascertain and assure the integrity and acceptable quality of the materials incorporated and the work performed. Inspection presence may be either full-time or intermittent, and neither the presence nor absence at any time of the CONSULTANT or the INSPECTOR shall relieve the CONTRACTOR of sole responsibility for the acceptability and integrity of the Work or any part thereof.

The costs of sampling, testing, and inspection on-site to ascertain acceptability of the Work and materials will be borne by the OWNER except as otherwise provided. The OWNER will select a testing laboratory to perform such sampling and testing. Sampling and/or testing required by the CONTRACTOR or necessitated by failure of Work or materials to meet the above acceptability test shall be at the expense of the CONTRACTOR.

Inspection services may be performed by the employees of the OWNER or by others selected or designated by the OWNER or the CONSULTANT.

Sampling and/or testing required for manufacturing quality and/or process control, for certification that raw mineral materials or manufactured products are the quality specified in the contract, or to assure the acceptability for incorporation into the Work shall be borne by the CONTRACTOR or the material supplier.

Cost for inspection, sampling, testing, and approvals required by the laws or regulations of any public body having competent jurisdiction shall be borne by the CONTRACTOR or the material supplier.

Sampling and testing will be in accord with pertinent codes and regulations and with appropriate standards of the American Society of Testing Materials or other specified standards.

12.3.3 On-Site Construction Test and Other Testing

All inspections, tests or approvals other than those required by Laws or Regulations of any public body having jurisdiction shall be performed by organizations acceptable to OWNER and CONTRACTOR (or by CONSULTANT if so specified).

12.3.4 Covered Work

If any Work (including the work of others) that is to be inspected, tested or approved is covered without written concurrence of CONSULTANT, it must, if requested by CONSULTANT, be uncovered for observation. Such uncovering shall be at CONTRACTOR'S expense unless CONTRACTOR has given CONSULTANT timely notice of CONTRACTOR'S intention to cover the same and CONSULTANT has not acted with reasonable promptness in response to such notice.

12.3.5 CONTRACTOR'S Obligation

Neither observations by CONSULTANT nor inspections, tests or approvals by others shall relieve CONTRACTOR from CONTRACTOR'S obligations to perform the Work in accordance with the Contract Documents.

12.4 OWNER May Stop the Work

If the Work is defective, or CONTRACTOR fails to supply sufficient skilled workers or suitable materials or equipment, or fails to furnish or perform the Work in such a way that the completed Work will conform to the Contract Documents, OWNER may order CONTRACTOR to stop the Work, or any portion thereof, until the cause for such order has been eliminated; however, this right of OWNER to stop the Work shall not give rise to any duty on the part of OWNER to exercise this right for the benefit of CONTRACTOR or any other party.

12.5 Correction or Removal of Defective Work

If required by CONSULTANT, CONTRACTOR shall promptly, as directed, either correct all defective Work, whether or not fabricated, installed or completed, or, if the Work has been rejected by CONSULTANT, remove it from the site and replace it with non-defective Work. CONTRACTOR shall bear all direct, indirect and consequential costs of such correction or removal (including but not limited to fees and charges of engineers, architects, attorneys and other professionals) made necessary thereby.

12.6 One Year Correction Period

If within one year after the date of Completion or such longer period of time as may be prescribed by Laws or Regulations or by the terms of any applicable special guarantee required by the Contract Documents or by any specific provision of the Contract Documents, any Work is found to be defective, CONTRACTOR shall promptly, without cost to OWNER and in accordance with OWNER'S written instructions, either correct such defective Work, or, if it has been rejected by OWNER, remove it from the site and replace it with non-defective Work. If CONTRACTOR does not promptly comply with the terms of such instructions, or in an emergency where delay would cause serious risk of loss or damage, OWNER may have the defective Work corrected or the rejected Work removed and replaced, and all direct, indirect and consequential costs of such removal and replacement

(including but not limited to fees and charges of engineers, architects, attorneys and other professionals) will be paid by CONTRACTOR. In special circumstances where a particular item of equipment is placed in continuous service before Completion of all the Work, the correction period for that item may start to run from an earlier date if so provided in the Specifications or by Change Order.

12.7 Acceptance of Defective Work

If, instead of requiring correction or removal and replacement of defective Work, OWNER prefers to accept it, OWNER may do so. CONTRACTOR shall bear all direct, indirect and consequential costs attributable to OWNER'S evaluation of and determination to accept such defective Work (such costs to be approved by CONSULTANT as to reasonableness and to include but not be limited to fees and charges of engineers, architects, attorneys and other professionals).

12.8 OWNER May Correct Defective Work

If CONTRACTOR fails within a reasonable time after written notice of CONSULTANT to proceed to correct and to correct defective Work or to remove and replace rejected Work as required by CONSULTANT in accordance with paragraph 12.5, or if CONTRACTOR fails to perform the Work in accordance with the Contract Documents, or if CONTRACTOR fails to comply with any other provision of the Contract Documents, OWNER may, after seven days' written notice to CONTRACTOR, correct and remedy any such deficiency. In exercising the rights and remedies under this paragraph OWNER shall proceed expeditiously. To the extent necessary to complete corrective and remedial action, OWNER may exclude CONTRACTOR from all or part of the site, take possession of all or part of the Work, and suspend CONTRACTOR'S services related thereto, take possession of CONTRACTOR'S tools, appliances, construction equipment and machinery at the site and incorporate in the Work all materials and equipment stored at the site or for which OWNER has paid CONTRACTOR but which are stored elsewhere. CONTRACTOR shall allow OWNER, OWNER'S representatives, agents and employees such access to the site as may be necessary to enable OWNER to exercise the rights and remedies under this paragraph. All direct, indirect and consequential costs of OWNER in exercising such rights and remedies will be charged against CONTRACTOR in an amount approved as to reasonableness by CONSULTANT, and a Change Order will be issued incorporating the necessary revisions in the Contract Documents with respect to the Work; and OWNER shall be entitled to an appropriate decrease in the Contract Price. Such direct, indirect and consequential costs will include but not be limited to fees and charges of engineers, architects, attorneys and other professionals, all court costs and all costs of repair and replacement of work of others destroyed or damaged by correction, removal or replacement of CONTRACTOR'S defective Work. CONTRACTOR shall not be allowed an extension of the Contract Time because of any delay in performance of the Work attributable to the exercise by OWNER of OWNER'S rights and remedies hereunder.

13. PAYMENTS TO CONTRACTOR AND COMPLETION

13.1 Schedule of Values

The schedule of values established as provided in paragraph 2.8 will serve as the basis for progress payments and will be incorporated into a form of Application for Payment acceptable to CONSULTANT. Progress payments on account of Unit Price Work will be based on the number of units completed.

13.2 Application for Progress Payment

At least ten days before each progress payment is scheduled (but not more often than once a month), CONTRACTOR shall submit to CONSULTANT for review an Application for Payment filled out and signed by CONTRACTOR covering the Work completed as of the date of the Application and accompanied by such supporting documentation as is required by the Contract Documents. If payment is requested on the basis of materials and equipment not incorporated in the Work but delivered and suitably stored at the site or at another location agreed to in writing, the Application for Payment shall also be accompanied by a bill of sale, invoice or other documentation warranting that OWNER has received the materials and equipment free and clear of all liens, charges, security interests and encumbrances (which are hereinafter in these General Conditions referred to as "Liens") and evidence that the materials and equipment are covered by appropriate property insurance and other arrangements to protect OWNER'S interest therein, all of which will be satisfactory to OWNER. OWNER shall, within thirty (30) calendar days of presentation to him of an approved Application for Payment, pay CONTRACTOR the amount approved by CONSULTANT. Monthly progress payments shall be ninety (90) percent of the sum obtained by applying the respective bid unit prices to the approved estimated quantities of work completed by the Contractor during the preceding month. The remaining ten (10) percent will be held by the Owner, as retainage. At such time as the CONSULTANT deems appropriate - based on the quality of work performed, progress of cleanup, and other pertinent factors - the rate of retainage, or the total amount retained, may be reduced; although, any reduction in retainage, below the ten (10) percent level, is made solely at the CONSULTANT's discretion. All remaining retainage held will be included in the final payment to the Contractor.

13.3 CONTRACTOR'S Warranty of Title

CONTRACTOR warrants and guarantees that title to all Work, materials and equipment covered by any Application for Payment, whether incorporated in the Project or not, will pass to OWNER no later than the time of payment free and clear of all Liens.

13.4 Review of Applications for Progress Payment

13.4.1 Submission of Application for Payment

CONSULTANT will, after receipt of each Application for Payment, either indicate in writing a recommendation of payment and present the Application to OWNER, or return the Application to CONTRACTOR indicating in writing CONSULTANT'S reasons for refusing to recommend payment. In the latter case, CONTRACTOR may make the necessary corrections and resubmit the Application.

13.4.2 CONSULTANT'S Recommendation

CONSULTANT may refuse to recommend the whole or any part of any payment, if, in CONSULTANT'S opinion, it would be incorrect to make such representations to OWNER. CONSULTANT may also refuse to recommend any such payment, or, because of subsequently discovered evidence or the results of subsequent inspections or tests, nullify any such payment previously recommended, to such extent as may be necessary in CONSULTANT'S opinion to protect OWNER from loss because:

13.4.2.1 the Work is defective, or completed Work has been damaged requiring correction or replacement;

13.4.2.2 the Contract Price has been reduced by Written Amendment or Change Order;

13.4.2.3 OWNER has been required to correct defective Work or complete Work in accordance with paragraph 12.8; or

13.4.2.4 of CONSULTANT's actual knowledge of the occurrence of any of the events enumerated in paragraphs 14.2.1 through 14.2.9 inclusive.

13.5 Partial Utilization

OWNER at any time may request CONTRACTOR in writing to permit OWNER to use any such part of the Work which OWNER believes to be ready for its intended use and has been completed. If CONTRACTOR agrees, CONTRACTOR will certify to OWNER that said part of the Work is complete and request that a Certificate of Completion be issued for that part of the Work.

13.6 Final Inspection

Upon written notice from CONTRACTOR that the entire Work or an agreed portion thereof is complete, CONSULTANT will make a final inspection with CONTRACTOR and will notify CONTRACTOR in writing of all particulars in which this inspection reveals that the Work is incomplete or defective. CONTRACTOR shall immediately take such measures as are necessary to remedy such deficiencies.

13.7 Final Application for Payment

After CONTRACTOR has completed all such corrections to the satisfaction of CONSULTANT and delivered all maintenance and operating instructions, schedules, guarantees, Bonds, certificates of inspection, marked-up record documents (as provided in paragraph 5.14) and other documents - all as required by the Contract Documents, and after CONSULTANT has indicated that the Work is acceptable (subject to the provisions of paragraph 13.10), CONTRACTOR may make application for final payment following the procedure for progress payments. The final Application for Payment shall be accompanied by all documentation called for in the Contract Documents, together with complete and legally effective releases or waivers (satisfactory to OWNER) of all Liens arising out of or filed in connection with the Work. In lieu thereof and as approved by OWNER, CONTRACTOR may furnish receipts or releases in full; an affidavit of CONTRACTOR that the releases and receipts include all labor, services, material and equipment for which a Lien could be filed, and that all payrolls, material and equipment bills, and other indebtedness connected with the Work for which OWNER or OWNER'S property might in any way be responsible, have been paid or otherwise satisfied; and consent of the surety, if any, to final payment. If any Subcontractor or Supplier fails to furnish a release or receipt in full, CONTRACTOR may furnish a Bond or other collateral satisfactory to OWNER to indemnify OWNER against any Lien.

13.8 Final Payment and Acceptance

13.8.1 CONSULTANT'S Approval

If, on the basis of CONSULTANT'S observation of the Work during construction and final inspection, and CONSULTANT'S review of the final Application for Payment and accompanying documentation - all as required by the Contract Documents, CONSULTANT is satisfied that the Work has been completed and CONTRACTOR'S other obligations under the Contract Documents have been fulfilled, CONSULTANT will, after receipt of the final Application for Payment, indicate in writing CONSULTANT'S recommendation of payment and present the Application to OWNER for payment. Thereupon CONSULTANT will give written notice to OWNER and CONTRACTOR that the Work is acceptable, subject to the provisions of paragraph 13.10. Otherwise, CONSULTANT will return the Application to CONTRACTOR, indicating in writing the reasons for refusing to recommend final payment, in which case CONTRACTOR shall make the necessary corrections and resubmit the Application.

13.8.2 Delay in Completion of Work

If, through no fault of CONTRACTOR, final completion of the Work is significantly delayed, OWNER shall, upon receipt of CONTRACTOR'S final Application for Payment and recommendation of CONSULTANT, and without terminating the Agreement, make payment of the balance due for that portion of the Work fully completed and accepted. If the remaining balance to be held by OWNER for Work not fully completed or corrected is

less than the retainage stipulated in the Agreement, and if Bonds have been furnished as required in paragraph 10 of Part II, Information for Bidders, the written consent of the surety to the payment of the balance due for that portion of the Work fully completed and accepted shall be submitted by CONTRACTOR to CONSULTANT with the Application for such payment. Such payment shall be made under the terms and conditions governing final payment, except that it shall not constitute a waiver of claims.

13.9 CONTRACTOR'S Continuing Obligation

CONTRACTOR'S obligation to perform and complete the Work in accordance with the Contract Documents shall be absolute. Neither recommendation of any progress or final payment by CONSULTANT, nor the issuance of a certificate of Completion, nor any payment by OWNER to CONTRACTOR under the Contract Documents, nor any use or occupancy of the Work or any part thereof by OWNER, nor any act of acceptance by OWNER nor any failure to do so, nor any review and approval of a Shop Drawing or sample submission, nor any correction of defective Work by OWNER will constitute an acceptance of Work not in accordance with the Contract Documents or a release of CONTRACTOR'S obligation to perform the Work in accordance with the Contract Documents (except as provided in paragraph 13.10).

13.10 Waiver of Claims

The making and acceptance of final payment will constitute:

13.10.1 a waiver of all claims by OWNER against CONTRACTOR, except claims arising from unsettled Liens, from defective Work appearing after final inspection or from failure to comply with the Contract Documents or the terms of any special guarantees specified therein; however, it will not constitute a waiver by OWNER of any rights in respect of CONTRACTOR'S continuing obligations under the Contract Documents; and

13.10.2 a waiver of all claims by CONTRACTOR against OWNER other than those previously made in writing and still unsettled.

14. SUSPENSION OF WORK AND TERMINATION

14.1 OWNER May Suspend Work

OWNER may, at any time and without cause, suspend the Work or any portion thereof for a period of not more than ninety days by notice in writing to CONTRACTOR and CONSULTANT which will fix the date on which Work will be resumed. CONTRACTOR shall resume the Work on the date so fixed. CONTRACTOR shall be allowed an increase in the Contract Price or an extension of the Contract Time, or both, directly attributable to any suspension if CONTRACTOR makes an approved claim therefor as provided in Articles 10 and 11.

14.2 OWNER May Terminate

The OWNER may terminate the Work upon the occurrence of any one or more of the following events:

14.2.1 if CONTRACTOR commences a voluntary case under any chapter of the Bankruptcy Code (Title 11, United States Code), as now or hereafter in effect, or if CONTRACTOR takes any equivalent or similar action by filing a petition or otherwise under any other federal or state law in effect at such time relating to the bankruptcy or insolvency;

14.2.2 if a petition is filed against CONTRACTOR under any chapter of the Bankruptcy Code as now or hereafter in effect at the time of filing, or if a petition is filed seeking any such equivalent or similar relief against CONTRACTOR under any other federal or state law in effect at the time relating to bankruptcy or insolvency;

14.2.3 if CONTRACTOR makes a general assignment for the benefit of creditors;

14.2.4 if a trustee, receiver, custodian or agent of CONTRACTOR is appointed under applicable law or under contract, whose appointment or authority to take charge of property of CONTRACTOR is for the purpose of enforcing a Lien against such property or for the purpose of general administration of such property for the benefit of CONTRACTOR'S creditors;

14.2.5 if CONTRACTOR admits in writing an inability to pay its debts generally as they become due;

14.2.6 if CONTRACTOR persistently fails to perform the Work in accordance with the Contract Documents (including, but not limited to, failure to supply sufficient skilled workers or suitable materials or equipment or failure to adhere to the progress schedule established under paragraph 2.8 as revised from time to time);

14.2.7 if CONTRACTOR disregards Laws or Regulations of any public body having jurisdiction;

14.2.8 if CONTRACTOR disregards the authority of CONSULTANT, or

14.2.9 if CONTRACTOR otherwise violates in any substantial way any provisions of the Contract Documents;

OWNER may, after giving CONTRACTOR (and the surety) seven days' written notice and to the extent permitted by Laws and Regulations,

terminate the services of CONTRACTOR, exclude CONTRACTOR from the site and take possession of the Work and of all CONTRACTOR'S tools, appliances, construction equipment and machinery at the site and use the same to the full extent they could be used by CONTRACTOR (without liability to CONTRACTOR for trespass or conversion), incorporate in the Work all materials and equipment stored at the site or for which OWNER has paid CONTRACTOR but which are stored elsewhere, and finish the Work as OWNER may deem expedient. In such case CONTRACTOR shall not be entitled to receive any further payment until the Work is finished. If the unpaid balance of the Contract Price exceeds the direct, indirect and consequential costs of completing the Work (including but not limited to fees and charges of engineers, architects, attorneys and other professionals and court and arbitration costs) such excess will be paid to CONTRACTOR. If such costs exceed such unpaid balance, CONTRACTOR shall pay the difference to OWNER. Such costs incurred by OWNER will be approved as to reasonableness by CONSULTANT and incorporated in a Change Order, but when exercising any rights or remedies under this paragraph OWNER shall not be required to obtain the lowest price for the Work performed.

14.2.10 If safety violations are observed and brought to the Contractors attention and Contractor fails to take immediate corrective measures any repeat of similar safety violations, Owner will order an immediate termination of contract. Note: it is the Contractor's responsibility to know proper safety measures as they pertain to construction and OSHA.

14.2.11 This contract may be canceled by either party thirty (30) days after delivery by canceling party of written notice of intent to cancel to the other contracting party.

14.2.12 This contract may be canceled by the Lexington-Fayette Urban County Government if it is determined that the Bidder has failed to perform under the terms of this agreement, such cancellation to be effective upon receipt of written notice of cancellation by the Bidder.

14.3 CONTRACTOR'S Services Terminated

Where CONTRACTOR'S services have been so terminated by OWNER, the termination will not affect any rights or remedies of OWNER against CONTRACTOR then existing or which may thereafter accrue. Any retention or payment of moneys due CONTRACTOR by OWNER will not release CONTRACTOR from liability.

14.4 Payment After Termination

Upon seven days' written notice to CONTRACTOR, OWNER may, without cause and without prejudice to any other right or remedy, elect to abandon the Work and terminate the Agreement. In such case, CONTRACTOR shall be paid for all Work executed and any expense sustained plus reasonable termination expenses, which

will include, but not be limited to, direct, indirect and consequential costs (including, but not limited to, fees and charges of engineers, architects, attorneys and other professionals and court and arbitration costs).

14.5 CONTRACTOR May Stop Work or Terminate

If, through no act or fault of CONTRACTOR, the Work is suspended for a period of more than ninety days by OWNER or under an order of court or other public authority, or CONSULTANT fails to act on any Application for Payment within sixty days after it is submitted, or OWNER fails for sixty days to pay CONTRACTOR any sum finally determined to be due, then CONTRACTOR may, upon seven days' written notice to OWNER and CONSULTANT, terminate the Agreement and recover from OWNER payment for all Work executed and any expense sustained plus reasonable termination expenses. In addition and in lieu of terminating the Agreement, if CONSULTANT has failed to act on an Application for Payment or OWNER has failed to make any payment as aforesaid, CONTRACTOR may upon seven days' written notice to OWNER and CONSULTANT stop the Work until payment of all amounts then due. The provisions of this paragraph shall not relieve CONTRACTOR of the obligations under paragraph 5.16 to carry on the Work in accordance with the progress schedule and without delay during disputes and disagreements with OWNER.

15. MISCELLANEOUS

15.1 Claims for Injury or Damage

Should OWNER or CONTRACTOR suffer injury or damage to person or property because of any error, omission or act of the other party or of any of the other party's employees or agents or others for whose acts the other party is legally liable, claim will be made in writing to the other party within a reasonable time of the first observance of such injury or damage. The provisions of this paragraph 15.1 shall not be construed as a substitute for or a waiver of the provisions of any applicable statute of limitations or repose.

15.2 Non-Discrimination in Employment

The CONTRACTOR shall comply with the following requirements prohibiting discrimination:

15.2.1 That no person (as defined in KRS 344.010) shall bid on Lexington-Fayette Urban County Government construction projects, or bid to furnish materials or supplies to the Lexington-Fayette Urban County Government, if, within six months prior to the time of opening of bids, said person shall have been found, by declaratory judgment action in Fayette Circuit Court, to be presently engaging in an unlawful practice, as hereinafter defined. Such declaratory judgment action may be brought by an aggrieved individual or upon an allegation that an effort at conciliation pursuant to KRS 344.200 has been attempted and failed, by the Lexington-Fayette County Human Rights Commission.

15.2.2 That it is an unlawful practice for an employer:

15.2.2.1 to fail or refuse to hire, or to discharge any individual or otherwise to discriminate against an individual, with respect to his compensation, terms, conditions, or privileges of employment, because of such individual's race, color, religion, sex, age, or national origin; or

15.2.2.2 to limit, segregate or classify his employees in any way which would deprive or tend to deprive an individual of employment opportunities or otherwise adversely affect his status as an employee because of such individual's sex, race, color, religion, age, or national origin.

15.2.3 That it is an unlawful practice for an employer, labor organization, or joint-labor management committee controlling apprenticeship or other training or retraining, including on-the-job training programs to discriminate against an individual because of his race, color, religion, sex, age, or national origin in admission to, or employment in, any program established to provide apprenticeship or other training.

15.2.4 That a copy of this Ordinance shall be furnished all suppliers and made a part of all bid specifications.

15.2.5 This Ordinance shall take effect after it is signed, published and recorded, as required by law.

15.3 Temporary Street Closing or Blockage

The CONTRACTOR will notify the CONSULTANT at least 72 hours prior to making any temporary street closing or blockage. This will permit orderly notification to all concerned public agencies. Specific details and restrictions on street closure or blockage are contained in the Special Conditions.

15.4 Percentage of Work Performed by prime CONTRACTOR

The CONTRACTOR shall perform on site, and with its own organization, Work equivalent to at least fifty (50%) percent of the total amount of Work to be performed under the Contract. This percentage may be reduced by a supplemental agreement to this Contract if, during performing the Work, the CONTRACTOR requests a reduction and the CONSULTANT determines that the reduction would be to the advantage of the OWNER.

15.5 Clean-up

Clean-up shall progress, to the greatest degree practicable, throughout the course of the Work. The Work will not be considered as completed, and final payment will not be made, until the right-of-way and all ground occupied or affected by the

Contractor in connection with the Work has been cleared of all rubbish, equipment, excess materials, temporary structures, and weeds. Rubbish and all waste materials of whatever nature shall be disposed of, off of the project site, in an acceptable manner. All property, both public and private, which has been damaged in the prosecution of the Work, shall be restored in an acceptable manner. All areas shall be draining, and all drainage ways shall be left unobstructed, and in such a condition that drift will not collect or scour be induced.

15.6 General

The duties and obligations imposed by these General Conditions and the rights and remedies available hereunder to the parties hereto, and, in particular but without limitation, the warranties, guarantees and obligations imposed upon CONTRACTOR by paragraphs 12.1, 12.3.5, 13.3, and 15.2 and all of the rights and remedies available to OWNER and CONSULTANT thereunder, are in addition to, and are not to be construed in any way as a limitation of, any rights and remedies available to any or all of them which are otherwise imposed or available by Laws or Regulations, by special warranty or guarantee or by other provisions of the Contract Documents, and the provisions of this paragraph will be as effective as if repeated specifically in the Contract Documents in connection with each particular duty, obligation, right and remedy to which they apply. All representations, warranties and guarantees made in the Contract Documents will survive final payment and termination or completion of the Agreement.

15.7 Debris Disposal

For all LFUCG projects any trash, construction demolition debris, yard waste, dirt or debris of any kind that is removed from the project site must be disposed of in accordance with local, state, and federal regulations. The disposal site or facility must be approved in advance by the LFUCG and disposal documentation is required. The Contractor will be responsible for payment of any fines associated with improper disposal of material removed from the project site.

END OF SECTION

PART V
SPECIAL CONDITIONS
INDEX

1	BLASTING.....	SC-2
2	RISK MANAGEMENT PROVISIONS – INSURANCE AND INDEMNIFICATION	SC-3
3	WAGE SCALE (if applicable)	SC-7

1. **BLASTING** – not applicable.

2. **RISK MANAGEMENT PROVISIONS**
INSURANCE AND INDEMNIFICATION

INDEMNIFICATION AND HOLD HARMLESS PROVISION

- (1) It is understood and agreed by the parties that Contractor hereby assumes the entire responsibility and liability for any and all damages to persons or property caused by or resulting from or arising out of any act or omission on the part of Contractor or its employees, agents, servants, owners, principals, licensees, assigns or subcontractors of any tier (hereinafter "CONTRACTOR") under or in connection with this agreement and/or the provision of goods or services and the performance or failure to perform any work required thereby.
- (2) CONTRACTOR shall indemnify, save, hold harmless and defend the Lexington-Fayette Urban County Government and its elected and appointed officials, employees, agents, volunteers, and successors in interest (hereinafter "LFUCG") from and against all liability, damages, and losses, including but not limited to, demands, claims, obligations, causes of action, judgments, penalties, fines, liens, costs, expenses, interest, defense costs and reasonable attorney's fees that are in any way incidental to or connected with, or that arise or are alleged to have arisen, directly or indirectly, from or by CONTRACTOR's performance or breach of the agreement and/or the provision of goods or services provided that: (a) it is attributable to personal injury, bodily injury, sickness, or death, or to injury to or destruction of property (including the loss of use resulting therefrom), or to or from the negligent acts, errors or omissions or willful misconduct of the CONTRACTOR; and (b) not caused solely by the active negligence or willful misconduct of LFUCG.
- (3) In the event LFUCG is alleged to be liable based upon the above, CONTRACTOR shall defend such allegations and shall bear all costs, fees and expenses of such defense, including but not limited to, all reasonable attorneys' fees and expenses, court costs, and expert witness fees and expenses, using attorneys approved in writing by LFUCG, which approval shall not be unreasonably withheld.
- (4) These provisions shall in no way be limited by any financial responsibility or insurance requirements, and shall survive the termination of this agreement.
- (5) LFUCG is a political subdivision of the Commonwealth of Kentucky. Vendor acknowledges and agrees that LFUCG is unable to provide indemnity or otherwise save, hold harmless, or defend the Vendor in any manner.

FINANCIAL RESPONSIBILITY

BIDDER/CONTRACTOR understands and agrees that it shall, prior to final acceptance of its bid and the commencement of any work, demonstrate the ability to assure compliance with the above Indemnity provisions and these other risk management provisions.

INSURANCE REQUIREMENTS

YOUR ATTENTION IS DIRECTED TO THE INSURANCE REQUIREMENTS BELOW, AND YOU MAY NEED TO CONFER WITH YOUR INSURANCE AGENTS, BROKERS, OR CARRIERS TO DETERMINE IN ADVANCE OF SUBMISSION OF A RESPONSE THE AVAILABILITY OF THE INSURANCE COVERAGES AND ENDORSEMENTS REQUIRED HEREIN. IF YOU FAIL TO COMPLY WITH THE INSURANCE REQUIREMENTS BELOW, YOU MAY BE DISQUALIFIED FROM AWARD OF THE CONTRACT.

Required Insurance Coverage

BIDDER/CONTRACTOR shall procure and maintain for the duration of this contract the following or equivalent insurance policies at no less than the limits shown below and cause its subcontractors to maintain similar insurance with limits acceptable to LFUCG in order to protect LFUCG against claims for injuries to persons or damages to property which may arise from or in connection with the performance of the work hereunder by CONTRACTOR. The cost of such insurance shall be included in any bid:

<u>Coverage</u>	<u>Limits</u>
General Liability aggregate (Insurance Services Office Form CG 00 01)	\$1 million per occurrence, \$2 million or \$2 million combined single limit
Commercial Automobile Liability occurrence (Insurance Services Office Form CA 0001)	combined single, \$1 million per
Worker's Compensation	Statutory
Employer's Liability	\$500,000.00

The policies above shall contain the following conditions:

- a. All Certificates of Insurance forms used by the insurance carrier shall be properly filed and approved by the Department of Insurance for the Commonwealth of Kentucky (DOI). LFUCG shall be named as an additional insured in the General Liability Policy and Commercial Automobile Liability Policy using the Kentucky DOI approved forms.
- b. The General Liability Policy shall be primary to any insurance or self-insurance retained by LFUCG.

c. The General Liability Policy shall include a Products and Completed Operations endorsement or Premises and Operations Liability endorsement unless it is deemed not to apply by LFUCG.

d. LFUCG shall be provided at least 30 days advance written notice via certified mail, return receipt requested, in the event any of the required policies are canceled or non-renewed.

e. Said coverage shall be written by insurers acceptable to LFUCG and shall be in a form acceptable to LFUCG. Insurance placed with insurers with a rating classification of no less than Excellent (A or A-) and a financial size category of no less than VIII, as defined by the most current Best's Key Rating Guide shall be deemed automatically acceptable.

Renewals

After insurance has been approved by LFUCG, evidence of renewal of an expiring policy must be submitted to LFUCG, and may be submitted on a manually signed renewal endorsement form. If the policy or carrier has changed, however, new evidence of coverage must be submitted in accordance with these Insurance Requirements.

Deductibles and Self-Insured Programs

IF YOU INTEND TO SUBMIT A SELF-INSURANCE PLAN IT MUST BE FORWARDED TO LEXINGTON-FAYETTE URBAN COUNTY GOVERNMENT, DIVISION OF RISK MANAGEMENT, 200 EAST MAIN STREET, LEXINGTON, KENTUCKY 40507 NO LATER THAN A MINIMUM OF FIVE (5) WORKING DAYS PRIOR TO THE RESPONSE DATE. Self-insurance programs, deductibles, and self-insured retentions in insurance policies are subject to separate approval by Lexington-Fayette Urban County Government's Division of Risk Management, upon review of evidence of BIDDER/CONTRACTOR's financial capacity to respond to claims. Any such programs or retentions must provide LFUCG with at least the same protection from liability and defense of suits as would be afforded by first-dollar insurance coverage. If BIDDER/CONTRACTOR satisfies any portion of the insurance requirements through deductibles, self-insurance programs, or self-insured retentions, BIDDER/CONTRACTOR agrees to provide Lexington-Fayette Urban County Government, Division of Risk Management, the following data prior to the final acceptance of bid and the commencement of any work:

- a. Latest audited financial statement, including auditor's notes.
- b. Any records of any self-insured trust fund plan or policy and related accounting statements.
- c. Actuarial funding reports or retained losses.

- d. Risk Management Manual or a description of the self-insurance and risk management program.
- e. A claim loss run summary for the previous five (5) years.
- f. Self-Insured Associations will be considered.

Safety and Loss Control

CONTRACTOR shall comply with all applicable federal, state, and local safety standards related to the performance of its works or services under this Agreement and take necessary action to protect the life, health and safety and property of all of its personnel on the job site, the public, and LFUCG.

Verification of Coverage

BIDDER/CONTRACTOR agrees to furnish LFUCG with all applicable Certificates of Insurance signed by a person authorized by the insurer to bind coverage on its behalf prior to final award, and if requested, shall provide LFUCG copies of all insurance policies, including all endorsements.

Right to Review, Audit and Inspect

CONTRACTOR understands and agrees that LFUCG may review, audit and inspect any and all of its records and operations to insure compliance with these Insurance Requirements.

DEFAULT

BIDDER/CONTRACTOR understands and agrees that the failure to comply with any of these insurance, safety, or loss control provisions shall constitute default and that LFUCG may elect at its option any single remedy or penalty or any combination of remedies and penalties, as available, including but not limited to purchasing insurance and charging BIDDER/CONTRACTOR for any such insurance premiums purchased, or suspending or terminating the work.

00357187

3. **WAGE SCALES** – not applicable.

END OF SECTION

PART VI
CONTRACT AGREEMENT

INDEX

1.	SCOPE OF WORK.....	CA-2
2.	TIME OF COMPLETION.....	CA-2
3.	ISSUANCE OF WORK ORDERS	CA-2
4.	THE CONTRACT SUM	CA-2
5.	PROGRESS PAYMENTS	CA-3
6.	ACCEPTANCE AND FINAL PAYMENT.....	CA-3
7.	THE CONTRACT DOCUMENTS.....	CA-3
8.	EXTRA WORK.....	CA-3
9.	ENUMERATION OF SPECIFICATIONS AND DRAWINGS.....	CA-4

PART VI

CONTRACT AGREEMENT

THIS AGREEMENT, made on the 17th day of MARCH, 2016, by and between Lexington-Fayette Urban County Government, acting herein called "OWNER" and TENNIS TECHNOLOGY INC, doing business as (an individual) (a partnership) (a corporation) located in the City of LOUISVILLE, County of JEFFERSON, and State of KY, hereinafter called "CONTRACTOR."

WITNESSETH: That the CONTRACTOR and the OWNER in consideration of ninety nine thousand 213 hundred forty 013/100 Dollars and Zero Cents (\$ 99,848.00) quoted in the proposal by the CONTRACTOR, dated Feb 2nd 2016, hereby agree to commence and complete the construction described as follows:

1. SCOPE OF WORK

The CONTRACTOR shall furnish all the materials, supplies, machinery, equipment, tools, superintendence, labor, insurance, and other accessories and services necessary to complete the said project in accordance with the conditions and prices stated in the Proposal, the General Conditions, and the Special Conditions of the Contract, the Specifications and Contract Documents therefore as prepared by Division of Parks and Recreation for Southland Park Tennis Court Renovation project.

2. TIME OF COMPLETION

The time period estimated and authorized by the OWNER for the proper execution of the Work by the Contract, in full, is hereby fixed as sixty (60) calendar days. The time shall begin in accordance with the Notice to Proceed provided by OWNER.

3. ISSUANCE OF WORK ORDERS

Notice to begin Work will be given in whole or for part of the Work as determined by the OWNER pending the availability of funds. The order of construction will be as determined by the Engineer after consultation with the CONTRACTOR and the OWNER.

4. THE CONTRACT SUM

The OWNER agrees to pay the CONTRACTOR in current funds for the performance of the Contract, as quoted in the proposal, subject to any additions and deductions, as provided therein.

5. PROGRESS PAYMENTS

The OWNER shall make payments on account of the Contract, as provided in accordance with the General Conditions, as estimated by the Engineer, less the aggregate of previous payments.

6. ACCEPTANCE AND FINAL PAYMENT

Final payment shall be due within ninety (90) days after completion of the Work, provided the Work be then fully completed and the Contract fully accepted.

Before issuance of final certificate, the CONTRACTOR shall submit evidence satisfactory to the Engineer that all payrolls, material bills, and other indebtedness connected with the Work has been paid.

If, after the Work has been substantially completed, full completion thereof is materially delayed through no fault of the CONTRACTOR, and the ENGINEER so certifies, the OWNER shall upon certificate of the ENGINEER, and without terminating the Contract, make payment of the balance due for that portion of the Work fully completed and accepted. Such payment shall be made under the terms and conditions governing final payment, except that it shall not constitute a waiver of claims.

7. THE CONTRACT DOCUMENTS

The Advertisement for Bids, Information for Bidders, the General Conditions, Performance and Payment Bonds, Contract Agreement, Special Conditions, Technical Specifications, any and all Addenda, and Proposal, and Plan Drawings form the Contract, and they are fully a part of the Contract as if hereto attached or herein repeated.

8. EXTRA WORK

The OWNER, without invalidating the Contract, may order extra work or make changes by altering, adding to or deducting from the Work, the Contract Sum being adjusted accordingly. All such Work shall be executed and paid for in accordance with the General Conditions, which is a part of this Contract.

9. THE FOLLOWING IS AN ENUMERATION OF THE SPECIFICATIONS AND DRAWINGS (CONTRACT DOCUMENTS):

SPECIFICATIONS

SECTION NO.	TITLE	PAGES
I	Advertisement for Bids	AB 1 thru 5
II	Information for Bidders	IB 1 thru 10
III	Form of Proposal	P 1 thru 36
IV	General Conditions	GC 1 thru 51
V	Special Conditions	SC 1 thru 7
VI	Contract Agreement	CA 1 thru 5
VII	Performance and Payment Bonds	PB 1 thru 7
VIII	Addenda	AD 1 thru 1
IX	Technical Specifications:	
	Bench Specifications	
	02270 – Erosion Control	
	02535B – Color Coating, Tennis	
	02613A – Court Surface Paving	
	02711 – Chain Link Fences	
	02831 – Chain Link Fences and Gates – PVC Coated	
	02870 – Site Specialties	

APPENDIX A Standard Drawings

IN WITNESSETH WHEREOF, the parties hereto have executed this Contract as of the date and year above written.

(Seal)

Lexington-Fayette Urban County Government.
Lexington, Kentucky

(Owner)

ATTEST:

[Signature]
Clerk of the Urban County Council

BY:

[Signature]
MAYOR

[Signature]
(Witness)

(Title)

(Seal)

TENALD Technology INC
(Contractor)

Cynthia B Long
(Secretary)* *Notary*

BY: [Signature]

(Witness)

RESIDENT
(Title)



PO Box 19709 Louisville Ky 40259
(Address and Zip Code)

IMPORTANT: *Strike out any non-applicable terms.

Secretary of the Owner should attest. If the CONTRACTOR is corporation, Secretary should attest. Give proper title of each person-executing Contract.

PART VII

PERFORMANCE AND PAYMENT BONDS

1. PERFORMANCE BOND
2. PAYMENT BOND

 **AIA** Document A312™ - 2010

Performance Bond

1118955

CONTRACTOR:

(Name, legal status and address)

Tennis Technology, Inc
P. O. Box 19709
Louisville, KY 40259

SURETY:

(Name, legal status and principal place of business)

Lexon Insurance Company
10002 Shelbyville Rd., Suite 100
Suite 100
Louisville, KY 40223

OWNER:

(Name, legal status and address)

Lexington-Fayette Urban County Government
Division of Purchasing
200 E. Main St., 3rd Fl., Room 308
Lexington, KY 40507

This document has important legal consequences. Consultation with an attorney is encouraged with respect to its completion or modification.

Any singular reference to Contractor, Surety, Owner or other party shall be considered plural where applicable.

AIA Document A312-2010 combines two separate bonds, a Performance Bond and a Payment Bond, into one form. This is not a single combined Performance and Payment Bond.

CONSTRUCTION CONTRACT

Date:

Amount: Ninety-Nine Thousand Eight Hundred Forty-Eight and 00/100

(\$ 99,848.00)

Description: Southland Park Tennis Court Renovation - Bid #6-2016
(Name and location)

BOND

Date:

(Not earlier than Construction Contract Date)

Amount: Ninety-Nine Thousand Eight Hundred Forty-Eight and 00/100

(\$ 99,848.00)

Modifications to this Bond: None See Section 16

CONTRACTOR AS PRINCIPAL

Company: *(Corporate Seal)*
Tennis Technology, Inc

SURETY

Company: *(Corporate Seal)*
Lexon Insurance Company

Signature: 

Name: Jeffrey Henderson
and Title: President

Signature: 

Name: Amy Meredith
and Title: Attorney-in-Fact

(Any additional signatures appear on the last page of this Performance Bond.)

(FOR INFORMATION ONLY — Name, address and telephone)

AGENT or BROKER:

Smith Manus
2307 River Road, Suite 200
Louisville, KY 40206
(800) 235-9347

OWNER'S REPRESENTATIVE:

(Architect, Engineer or other party:)

§ 1 The Contractor and Surety, jointly and severally, bind themselves, their heirs, executors, administrators, successors and assigns to the Owner for the performance of the Construction Contract, which is incorporated herein by reference.

§ 2 If the Contractor performs the Construction Contract, the Surety and the Contractor shall have no obligation under this Bond, except when applicable to participate in a conference as provided in Section 3.

§ 3 If there is no Owner Default under the Construction Contract, the Surety's obligation under this Bond shall arise after

- .1 the Owner first provides notice to the Contractor and the Surety that the Owner is considering declaring a Contractor Default. Such notice shall indicate whether the Owner is requesting a conference among the Owner, Contractor and Surety to discuss the Contractor's performance. If the Owner does not request a conference, the Surety may, within five (5) business days after receipt of the Owner's notice, request such a conference. If the Surety timely requests a conference, the Owner shall attend. Unless the Owner agrees otherwise, any conference requested under this Section 3.1 shall be held within ten (10) business days of the Surety's receipt of the Owner's notice. If the Owner, the Contractor and the Surety agree, the Contractor shall be allowed a reasonable time to perform the Construction Contract, but such an agreement shall not waive the Owner's right, if any, subsequently to declare a Contractor Default;
- .2 the Owner declares a Contractor Default, terminates the Construction Contract and notifies the Surety; and
- .3 the Owner has agreed to pay the Balance of the Contract Price in accordance with the terms of the Construction Contract to the Surety or to a contractor selected to perform the Construction Contract.

§ 4 Failure on the part of the Owner to comply with the notice requirement in Section 3.1 shall not constitute a failure to comply with a condition precedent to the Surety's obligations, or release the Surety from its obligations, except to the extent the Surety demonstrates actual prejudice.

§ 5 When the Owner has satisfied the conditions of Section 3, the Surety shall promptly and at the Surety's expense take one of the following actions:

§ 5.1 Arrange for the Contractor, with the consent of the Owner, to perform and complete the Construction Contract;

§ 5.2 Undertake to perform and complete the Construction Contract itself, through its agents or independent contractors;

§ 5.3 Obtain bids or negotiated proposals from qualified contractors acceptable to the Owner for a contract for performance and completion of the Construction Contract, arrange for a contract to be prepared for execution by the Owner and a contractor selected with the Owner's concurrence, to be secured with performance and payment bonds executed by a qualified surety equivalent to the bonds issued on the Construction Contract, and pay to the Owner the amount of damages as described in Section 7 in excess of the Balance of the Contract Price incurred by the Owner as a result of the Contractor Default; or

§ 5.4 Waive its right to perform and complete, arrange for completion, or obtain a new contractor and with reasonable promptness under the circumstances:

- .1 After investigation, determine the amount for which it may be liable to the Owner and, as soon as practicable after the amount is determined, make payment to the Owner; or
- .2 Deny liability in whole or in part and notify the Owner, citing the reasons for denial.

§ 6 If the Surety does not proceed as provided in Section 5 with reasonable promptness, the Surety shall be deemed to be in default on this Bond seven days after receipt of an additional written notice from the Owner to the Surety demanding that the Surety perform its obligations under this Bond, and the Owner shall be entitled to enforce any remedy available to the Owner. If the Surety proceeds as provided in Section 5.4, and the Owner refuses the payment or the Surety has denied liability, in whole or in part, without further notice the Owner shall be entitled to enforce any remedy available to the Owner.

§ 7 If the Surety elects to act under Section 5.1, 5.2 or 5.3, then the responsibilities of the Surety to the Owner shall not be greater than those of the Contractor under the Construction Contract, and the responsibilities of the Owner to the Surety shall not be greater than those of the Owner under the Construction Contract. Subject to the commitment by the Owner to pay the Balance of the Contract Price, the Surety is obligated, without duplication, for

- .1 the responsibilities of the Contractor for correction of defective work and completion of the Construction Contract;
- .2 additional legal, design professional and delay costs resulting from the Contractor's Default, and resulting from the actions or failure to act of the Surety under Section 5; and
- .3 liquidated damages, or if no liquidated damages are specified in the Construction Contract, actual damages caused by delayed performance or non-performance of the Contractor.

§ 8 If the Surety elects to act under Section 5.1, 5.3 or 5.4, the Surety's liability is limited to the amount of this Bond.

§ 9 The Surety shall not be liable to the Owner or others for obligations of the Contractor that are unrelated to the Construction Contract, and the Balance of the Contract Price shall not be reduced or set off on account of any such unrelated obligations. No right of action shall accrue on this Bond to any person or entity other than the Owner or its heirs, executors, administrators, successors and assigns.

§ 10 The Surety hereby waives notice of any change, including changes of time, to the Construction Contract or to related subcontracts, purchase orders and other obligations.

§ 11 Any proceeding, legal or equitable, under this Bond may be instituted in any court of competent jurisdiction in the location in which the work or part of the work is located and shall be instituted within two years after a declaration of Contractor Default or within two years after the Contractor ceased working or within two years after the Surety refuses or fails to perform its obligations under this Bond, whichever occurs first. If the provisions of this Paragraph are void or prohibited by law, the minimum period of limitation available to sureties as a defense in the jurisdiction of the suit shall be applicable.

§ 12 Notice to the Surety, the Owner or the Contractor shall be mailed or delivered to the address shown on the page on which their signature appears.

§ 13 When this Bond has been furnished to comply with a statutory or other legal requirement in the location where the construction was to be performed, any provision in this Bond conflicting with said statutory or legal requirement shall be deemed deleted herefrom and provisions conforming to such statutory or other legal requirement shall be deemed incorporated herein. When so furnished, the intent is that this Bond shall be construed as a statutory bond and not as a common law bond.

§ 14 Definitions

§ 14.1 Balance of the Contract Price. The total amount payable by the Owner to the Contractor under the Construction Contract after all proper adjustments have been made, including allowance to the Contractor of any amounts received or to be received by the Owner in settlement of insurance or other claims for damages to which the Contractor is entitled, reduced by all valid and proper payments made to or on behalf of the Contractor under the Construction Contract.

§ 14.2 Construction Contract. The agreement between the Owner and Contractor identified on the cover page, including all Contract Documents and changes made to the agreement and the Contract Documents.

§ 14.3 Contractor Default. Failure of the Contractor, which has not been remedied or waived, to perform or otherwise to comply with a material term of the Construction Contract.

§ 14.4 Owner Default. Failure of the Owner, which has not been remedied or waived, to pay the Contractor as required under the Construction Contract or to perform and complete or comply with the other material terms of the Construction Contract.

§ 14.5 Contract Documents. All the documents that comprise the agreement between the Owner and Contractor.

§ 15 If this Bond is issued for an agreement between a Contractor and subcontractor, the term Contractor in this Bond shall be deemed to be Subcontractor and the term Owner shall be deemed to be Contractor.

AIA Document A312™ – 2010

Payment Bond

1118955

CONTRACTOR:
(Name, legal status and address)

Tennis Technology, Inc
P. O. Box 19709
Louisville, KY 40259

SURETY:
(Name, legal status and principal place of business)

Lexon Insurance Company
10002 Shelbyville Rd., Suite 100
Suite 100
Louisville, KY 40223

OWNER:
(Name, legal status and address)

Lexington-Fayette Urban County Government
Division of Purchasing
200 E. Main St., 3rd Fl., Room 308
Lexington, KY 40507

CONSTRUCTION CONTRACT
Date:

Amount: Ninety-Nine Thousand Eight Hundred Forty-Eight and 00/100 (\$ 99,848.00)

Description: Southland Park Tennis Court Renovation - Bld #6-2016
(Name and location)

This document has important legal consequences. Consultation with an attorney is encouraged with respect to its completion or modification.

Any singular reference to Contractor, Surety, Owner or other party shall be considered plural where applicable.

AIA Document A312-2010 combines two separate bonds, a Performance Bond and a Payment Bond, into one form. This is not a single combined Performance and Payment Bond.

BOND

Date:
(Not earlier than Construction Contract Date)

Amount: Ninety-Nine Thousand Eight Hundred Forty-Eight and 00/100 (\$ 99,848.00)

Modifications to this Bond: None See Section 18

CONTRACTOR AS PRINCIPAL
Company: (Corporate Seal)
Tennis Technology, Inc

SURETY
Company: (Corporate Seal)
Lexon Insurance Company

Signature: 
Name: Jeff Henderson
and Title: President
(Any additional signatures appear on the last page of this Payment Bond.)

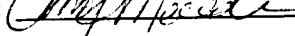
Signature: 
Name: Amy Meredith
and Title: Attorney-in-Fact

(FOR INFORMATION ONLY — Name, address and telephone)

AGENT or BROKER:

Smith Manus
2307 River Road, Suite 200
Louisville, KY 40206
(800) 235-9347

OWNER'S REPRESENTATIVE:
(Architect, Engineer or other party:)

§ 1 The Contractor and Surety, jointly and severally, bind themselves, their heirs, executors, administrators, successors and assigns to the Owner to pay for labor, materials and equipment furnished for use in the performance of the Construction Contract, which is incorporated herein by reference, subject to the following terms.

§ 2 If the Contractor promptly makes payment of all sums due to Claimants, and defends, indemnifies and holds harmless the Owner from claims, demands, liens or suits by any person or entity seeking payment for labor, materials or equipment furnished for use in the performance of the Construction Contract, then the Surety and the Contractor shall have no obligation under this Bond.

§ 3 If there is no Owner Default under the Construction Contract, the Surety's obligation to the Owner under this Bond shall arise after the Owner has promptly notified the Contractor and the Surety (at the address described in Section 13) of claims, demands, liens or suits against the Owner or the Owner's property by any person or entity seeking payment for labor, materials or equipment furnished for use in the performance of the Construction Contract and tendered defense of such claims, demands, liens or suits to the Contractor and the Surety.

§ 4 When the Owner has satisfied the conditions in Section 3, the Surety shall promptly and at the Surety's expense defend, indemnify and hold harmless the Owner against a duly tendered claim, demand, lien or suit.

§ 5 The Surety's obligations to a Claimant under this Bond shall arise after the following:

§ 5.1 Claimants, who do not have a direct contract with the Contractor,

- .1 have furnished a written notice of non-payment to the Contractor, stating with substantial accuracy the amount claimed and the name of the party to whom the materials were, or equipment was, furnished or supplied or for whom the labor was done or performed, within ninety (90) days after having last performed labor or last furnished materials or equipment included in the Claim; and
- .2 have sent a Claim to the Surety (at the address described in Section 13).

§ 5.2 Claimants, who are employed by or have a direct contract with the Contractor, have sent a Claim to the Surety (at the address described in Section 13).

§ 6 If a notice of non-payment required by Section 5.1.1 is given by the Owner to the Contractor, that is sufficient to satisfy a Claimant's obligation to furnish a written notice of non-payment under Section 5.1.1.

§ 7 When a Claimant has satisfied the conditions of Sections 5.1 or 5.2, whichever is applicable, the Surety shall promptly and at the Surety's expense take the following actions:

§ 7.1 Send an answer to the Claimant, with a copy to the Owner, within sixty (60) days after receipt of the Claim, stating the amounts that are undisputed and the basis for challenging any amounts that are disputed; and

§ 7.2 Pay or arrange for payment of any undisputed amounts.

§ 7.3 The Surety's failure to discharge its obligations under Section 7.1 or Section 7.2 shall not be deemed to constitute a waiver of defenses the Surety or Contractor may have or acquire as to a Claim, except as to undisputed amounts for which the Surety and Claimant have reached agreement. If, however, the Surety fails to discharge its obligations under Section 7.1 or Section 7.2, the Surety shall indemnify the Claimant for the reasonable attorney's fees the Claimant incurs thereafter to recover any sums found to be due and owing to the Claimant.

§ 8 The Surety's total obligation shall not exceed the amount of this Bond, plus the amount of reasonable attorney's fees provided under Section 7.3, and the amount of this Bond shall be credited for any payments made in good faith by the Surety.

§ 9 Amounts owed by the Owner to the Contractor under the Construction Contract shall be used for the performance of the Construction Contract and to satisfy claims, if any, under any construction performance bond. By the Contractor furnishing and the Owner accepting this Bond, they agree that all funds earned by the Contractor in the performance of the Construction Contract are dedicated to satisfy obligations of the Contractor and Surety under this Bond, subject to the Owner's priority to use the funds for the completion of the work.

§ 10 The Surety shall not be liable to the Owner, Claimants or others for obligations of the Contractor that are unrelated to the Construction Contract. The Owner shall not be liable for the payment of any costs or expenses of any Claimant under this Bond, and shall have under this Bond no obligation to make payments to, or give notice on behalf of, Claimants or otherwise have any obligations to Claimants under this Bond.

§ 11 The Surety hereby waives notice of any change, including changes of time, to the Construction Contract or to related subcontracts, purchase orders and other obligations.

§ 12 No suit or action shall be commenced by a Claimant under this Bond other than in a court of competent jurisdiction in the state in which the project that is the subject of the Construction Contract is located or after the expiration of one year from the date (1) on which the Claimant sent a Claim to the Surety pursuant to Section 5.1.2 or 5.2, or (2) on which the last labor or service was performed by anyone or the last materials or equipment were furnished by anyone under the Construction Contract, whichever of (1) or (2) first occurs. If the provisions of this Paragraph are void or prohibited by law, the minimum period of limitation available to sureties as a defense in the jurisdiction of the suit shall be applicable.

§ 13 Notice and Claims to the Surety, the Owner or the Contractor shall be mailed or delivered to the address shown on the page on which their signature appears. Actual receipt of notice or Claims, however accomplished, shall be sufficient compliance as of the date received.

§ 14 When this Bond has been furnished to comply with a statutory or other legal requirement in the location where the construction was to be performed, any provision in this Bond conflicting with said statutory or legal requirement shall be deemed deleted herefrom and provisions conforming to such statutory or other legal requirement shall be deemed incorporated herein. When so furnished, the intent is that this Bond shall be construed as a statutory bond and not as a common law bond.

§ 15 Upon request by any person or entity appearing to be a potential beneficiary of this Bond, the Contractor and Owner shall promptly furnish a copy of this Bond or shall permit a copy to be made.

§ 16 Definitions

§ 16.1 Claim. A written statement by the Claimant including at a minimum:

- .1 the name of the Claimant;
- .2 the name of the person for whom the labor was done, or materials or equipment furnished;
- .3 a copy of the agreement or purchase order pursuant to which labor, materials or equipment was furnished for use in the performance of the Construction Contract;
- .4 a brief description of the labor, materials or equipment furnished;
- .5 the date on which the Claimant last performed labor or last furnished materials or equipment for use in the performance of the Construction Contract;
- .6 the total amount earned by the Claimant for labor, materials or equipment furnished as of the date of the Claim;
- .7 the total amount of previous payments received by the Claimant; and
- .8 the total amount due and unpaid to the Claimant for labor, materials or equipment furnished as of the date of the Claim.

§ 16.2 Claimant. An individual or entity having a direct contract with the Contractor or with a subcontractor of the Contractor to furnish labor, materials or equipment for use in the performance of the Construction Contract. The term Claimant also includes any individual or entity that has rightfully asserted a claim under an applicable mechanic's lien or similar statute against the real property upon which the Project is located. The intent of this Bond shall be to include without limitation in the terms "labor, materials or equipment" that part of water, gas, power, light, heat, oil, gasoline, telephone service or rental equipment used in the Construction Contract, architectural and engineering services required for performance of the work of the Contractor and the Contractor's subcontractors, and all other items for which a mechanic's lien may be asserted in the jurisdiction where the labor, materials or equipment were furnished.

§ 16.3 Construction Contract. The agreement between the Owner and Contractor identified on the cover page, including all Contract Documents and all changes made to the agreement and the Contract Documents.

§ 16.4 Owner Default. Failure of the Owner, which has not been remedied or waived, to pay the Contractor as required under the Construction Contract or to perform and complete or comply with the other material terms of the Construction Contract.

§ 16.5 Contract Documents. All the documents that comprise the agreement between the Owner and Contractor.

§ 17 If this Bond is issued for an agreement between a Contractor and subcontractor, the term Contractor in this Bond shall be deemed to be Subcontractor and the term Owner shall be deemed to be Contractor.

§ 18 Modifications to this bond are as follows:

(Space is provided below for additional signatures of added parties, other than those appearing on the cover page.)

CONTRACTOR AS PRINCIPAL

SURETY

Company:

(Corporate Seal)

Company:

(Corporate Seal)

Signature: _____

Name and Title:

Address

Signature: _____

Name and Title:

Address

POWER OF ATTORNEY

LX- 268674

Lexon Insurance Company

KNOW ALL MEN BY THESE PRESENTS, that LEXON INSURANCE COMPANY, a Texas Corporation, with its principal office in Louisville, Kentucky, does hereby constitute and appoint: Brook T. Smith, Raymond M. Hundley, Jason D. Cromwell, James H. Martin, Barbara Duncan, Sandra L. Fusinetti, Mark A. Guidry, Jill Kemp, Lynnette Long, Amy Meredith, Deborah Neichter, Jessica Nowlin, Theresa Pickerrell, Sheryon Quinn, Bonnie J. Wortham, Beth Frymire its true and lawful Attorney(s)-In-Fact to make, execute, seal and deliver for, and on its behalf as surety, any and all bonds, undertakings or other writings obligatory in nature of a bond.

This authority is made under and by the authority of a resolution which was passed by the Board of Directors of LEXON INSURANCE COMPANY on the 1st day of July, 2003 as follows:

Resolved, that the President of the Company is hereby authorized to appoint and empower any representative of the Company or other person or persons as Attorney-In-Fact to execute on behalf of the Company any bonds, undertakings, policies, contracts of indemnity or other writings obligatory in nature of a bond not to exceed \$5,000,000.00, Five Million dollars, which the Company might execute through its duly elected officers, and affix the seal of the Company thereto. Any said execution of such documents by an Attorney-In-Fact shall be as binding upon the Company as if they had been duly executed and acknowledged by the regularly elected officers of the Company. Any Attorney-In-Fact, so appointed, may be removed for good cause and the authority so granted may be revoked as specified in the Power of Attorney.

Resolved, that the signature of the President and the seal of the Company may be affixed by facsimile on any power of attorney granted, and the signature of the Assistant Secretary, and the seal of the Company may be affixed by facsimile to any certificate of any such power and any such power or certificate bearing such facsimile signature and seal shall be valid and binding on the Company. Any such power so executed and sealed and certificate so executed and sealed shall, with respect to any bond of undertaking to which it is attached, continue to be valid and binding on the Company.

IN WITNESS THEREOF, LEXON INSURANCE COMPANY has caused this instrument to be signed by its President, and its Corporate Seal to be affixed this 5th day of August, 2015.

LEXON INSURANCE COMPANY



BY [Signature] David E. Campbell President

ACKNOWLEDGEMENT

On this 5th day of August, 2015, before me, personally came David E. Campbell to me known, who be duly sworn, did depose and say that he is the President of LEXON INSURANCE COMPANY, the corporation described in and which executed the above instrument; that he executed said instrument on behalf of the corporation by authority of his office under the By-laws of said corporation.



AMY TAYLOR Notary Public- State of Tennessee Davidson County Mv Commission Expires 07-08-19

BY [Signature] Amy Taylor Notary Public

CERTIFICATE

I, the undersigned, Assistant Secretary of LEXON INSURANCE COMPANY, A Texas Insurance Company, DO HEREBY CERTIFY that the original Power of Attorney of which the forgoing is a true and correct copy, is in full force and effect and has not been revoked and the resolutions as set forth are now in force.

Signed and Seal at Mount Juliet, Tennessee this _____ Day of _____, 20_____.



BY [Signature] Andrew Smith Assistant Secretary

WARNING: Any person who knowingly and with intent to defraud any insurance company or other person, files and application for insurance of claim containing any materially false information, or conceals for the purpose of misleading, information concerning any fact material thereto, commits a fraudulent insurance act, which is a crime and subjects such person to criminal and civil penalties.

PART VIII

ADDENDA

All addenda issued during the bidding of the Project will be reproduced in the signed Contract Documents, on the pages following this heading sheet.

<u>Addendum Number</u>	<u>Title</u>	<u>Date</u>
1.	_____	<u>1/27/16</u>
2.	_____	<u>2/2/16</u>
3.	_____	_____
4.	_____	_____
5.	_____	_____



Lexington-Fayette Urban County Government
DEPARTMENT OF FINANCE & ADMINISTRATION

Jim Gray
Mayor

William O'Mara
Commissioner

ADDENDUM #1

Bid Number: **#6-2016**

Date: January 27, 2016

Subject: **Southland Park Tennis Court Renovation**

Address inquiries to:
Kristie Thomas
(859) 258-3320

TO ALL PROSPECTIVE SUBMITTERS:

Please be advised of the following clarifications to the above referenced Bid:

1. Bid Opening has been moved to February 5, 2016, 2:00pm.
2. Part IX Technical Specifications, Section 02613A Court Surface Paving, Part 1 General, Section A Quality Assurance, Item 3 Thickness has been edited to read as:

In-place compacted thickness will not be acceptable if exceeding following allowable variation from thickness shown on drawings.

Base course: 1 ½", nominal +/-
 1 ¼" surface asphalt with aramid fibers
 Surface course: 1 ½", nominal +/-
 1 ¼" surface asphalt with aramid fibers

3. Part IX Technical Specifications, Section 02613A Court Surface Paving, Part 2 Materials, Gravel Aggregate has been edited to read as "6 inches compacted of Dense Grade Aggregate".
4. Disregard all gate references in Technical Specifications. Fence gates are not applicable in this project.
5. Part IX Technical Specifications, Section 02711 Chain Link Fences, Part 3 Products, Section D Performance Properties of the Product, Item 2 chart has been edited to read as:

	Diameter	SS40st/ft	6' Cantilever
Line posts	2"	2.280 lbs	195 lbs
End, corner post	3"	4.640 lbs	610 lbs
*Top rails	1-5/8"	1.836 lbs	135 lbs
*Braces	1-5/8"	1.836 lbs	135 lbs
*Gate frames	1-5/8"	1.836 lbs	135 lbs

- 6. Part IX Technical Specifications, Section 02831 Chain Link Fences and Gates – PVC Coated, Part 2 Products, 2.01 Materials, Section B Fabric – PVC Coated Item 1 has been edited to read as "Fabric shall be 9 gauge steel core wire".
- 7. Part IX Technical Specifications, Section 02831 Chain Link Fences and Gates – PVC Coated, Part 2 Products, 2.03 Components, Section A Fence Posts:

Type I-II

Line Post O.D.	Terminal Post O.D.
2"	3"

- 8. Revised site plan attached.
- 9. Pre-bid sign-in attached.



Todd Slatin, Director
Division of Central Purchasing

All other terms and conditions of the Bid and specifications are unchanged.
This letter should be signed, attached to and become a part of your Bid.

COMPANY NAME: TENNIS TECHNOLOGY INC

ADDRESS: PO Box 19709 Louisville KY 40299

SIGNATURE OF BIDDER: JML

SEE SPECIFICATIONS-
SECTION 02613A COURT SURFACE PAVING
SECTION 025356 TENNIS COLOR COATING NEW ASPHALT SURFACE

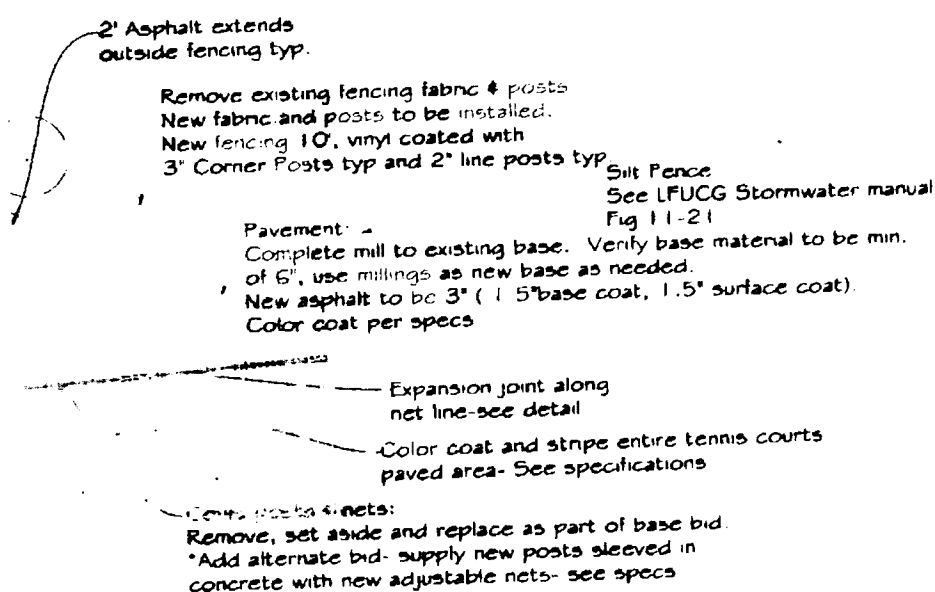

Notes:

1. Field verify all dimensions and grades.
2. Utilities shall be marked before any construction begins.
3. Site shall be kept clean and free of miscellaneous debris for the safety of park patrons.
4. All disturbed areas to be seeded and strawed upon completion of work.
5. Silt fence to remain in place until 90% cover is established- see fig 11-21 LFUCG Stormwater Manual

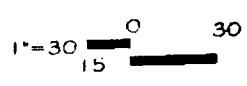
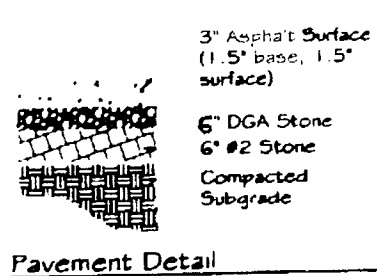
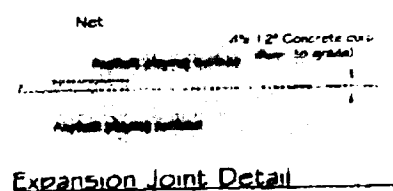

NOTE-
*All related work quantities to be measured and confirmed by contractor

Plan

Southland Park Tennis Resurfacing

LFUCG Division of Parks & Recreation

2015 Sept



Lexington-Fayette Urban County Government
DEPARTMENT OF FINANCE & ADMINISTRATION

Jim Gray
Mayor

William O'Mara
Commissioner

ADDENDUM #2

Bid Number: **#6-2016**

Date: February 2, 2016

Subject: **Southland Park Tennis Court Renovation**

Address Inquiries to:
Kristie Thomas
(859) 258-3320

TO ALL PROSPECTIVE SUBMITTERS:

Please be advised of the following clarifications to the above referenced Bid:

1. Bid Opening has been moved to February 9, 2016 at 2:00pm.
2. Court net line expansion joint work deleted. Revised site plan attached.

Todd Sletlin, Director
Division of Central Purchasing

All other terms and conditions of the Bid and specifications are unchanged.
This letter should be signed, attached to and become a part of your Bid.

COMPANY NAME: Tennis Technology Inc

ADDRESS: PO Box 19709 Louisville KY 40259

SIGNATURE OF BIDDER: [Handwritten Signature]

SEE SPECIFICATIONS-
SECTION 02613A COURT SURFACE PAVING
SECTION 02535B TENNIS COLOR COATING-NEW ASPHALT SURFACE

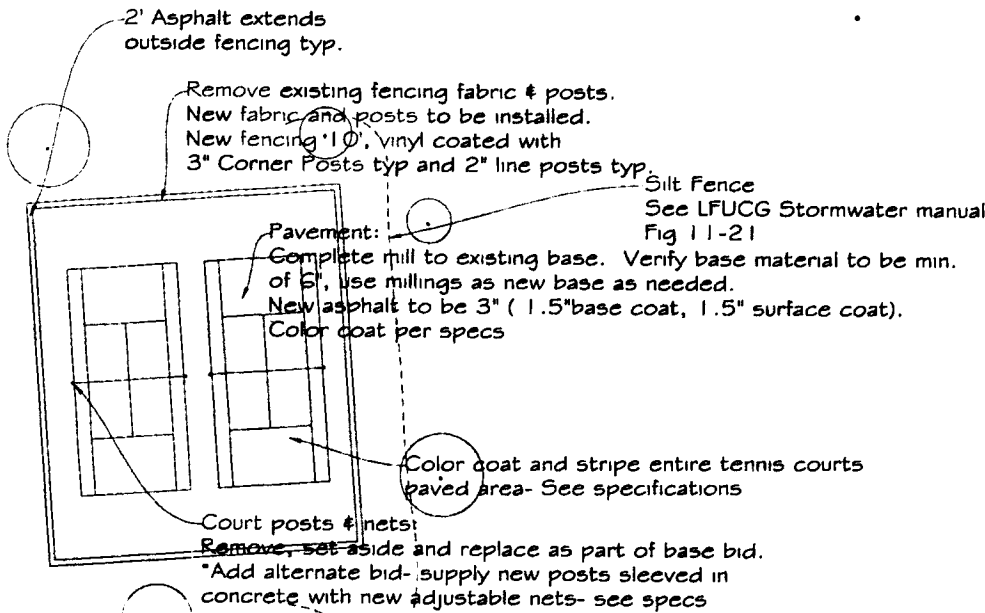

NOTE-
*All related work quantities to be measured and confirmed by contractor

Plan

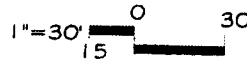

Notes:

1. Field verify all dimensions and grades.
2. Utilities shall be marked before any construction begins.
3. Site shall be kept clean and free of miscellaneous debris for the safety of park patrons.
4. All disturbed areas to be seeded and strawed upon completion of work.
5. Silt fence to remain in place until 90% cover is established- see fig 11-21 LFUCG Stormwater Manual

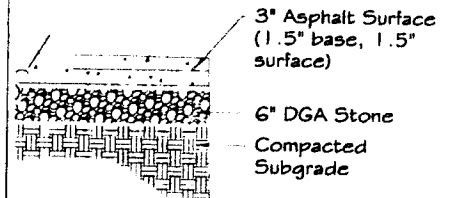

Pavement Detail

Southland Park Tennis Resurfacing

LFUCG Division of Parks & Recreation

2015 Sept

IX. TECHNICAL SPECIFICATIONS

BENCH SPECIFICATIONS:

Wabash Valley CN425D or Equal

Contemporary series 6' bench without back, surface mount.

Diamond pattern seat – Green

Surface mount frame - Black

Heavy duty 2 3/8" OD steel tubing

Half-inch diameter holes in each foot pad for surface mount

Heat infused poly-vinyl coating to 3/16" thickness

Framework assemblies finished with powder coating

Stainless steel Fasteners

Heat fused poly-vinyl coating, finished on inner-metal structure, to an approximate 3/16" thickness.

Framework assemblies are finished with powder coating; electrostatically applied and oven cured according to powder manufacturer's specifications. Fasteners are stainless steel to resist corrosion.

BENCH FRAME:

Main supports constructed of 2 7/8" od x 12 gage galvanized steel tubing.

Attach tubes constructed of 2 3/8" od x 12 gage tubing.

Both types of tubing are made from galvanized structural steel tubing.

Mounting brackets on the legs are 10 gage sheet steel and 1/4" x 1 1/2" flat bar steel.

Mounting plate covers are made of 2 piece cast aluminum.

Surface mount screw-in attachments are made of steel plate 114" x 6" with a 5/8" threaded stud.

BENCH SEAT:

Expanded metal seat uses 3/4" #9 expanded steel.

Rib seats use 10 gage and perforated seats use 12 gage sheet steel. Slats are 3/16" x 2 1/4" flat bar.

Bench's frame/mounting brackets are made from 10 gage sheet steel. Support braces, adding support to the bench's rolled-sides, are 1/4" x 1 1/4" flat bar steel.

GENERAL:

6' Contemporary Bench ground space requirements are 27 1/2" x 83". The bench seat is 72 1/8" long x 26 1/4" wide and 15 1/2" to the top of the lowest part in the bench's seat.

6' low profile bench ground space requirements are 30 3/8" x 83". The bench seat is 72 1/8" long x 30 3/8" wide and 16 1/2" to the top of the seat.

model no:

UP400D, UP400P, UP400R, UP400S,
UP405D, UP405P, UP405R, UP405S,
UP420D, UP420P, UP420R, UP420S,
UP425D, UP425P, UP425R, UP425S



WABASH VALLEY

© Wabash Valley Manufacturing, Inc.

UPTOWN SERIES

4' & 6' BENCH WITH & WITHOUT ARM
EXPANDED METAL, RIB, PERFORATED, & SLAT

customer service:

ASSEMBLERS: If you find any parts missing or damaged, or if you're having difficulty assembling your furniture/equipment, call us at:
Any correspondence concerning our product should be sent directly to our **Customer Service Manager** at:

* Before calling, have your product model number available.

1-800-253-8619 (Inside U.S.A.)
260-352-2102 (Outside U.S.A.)

Monday thru Friday,
8:00 AM - 4:30 PM Eastern Time
(EXCEPT HOLIDAYS)

Wabash Valley Manufacturing, Inc.
505 E. Main Street
P.O. Box 5
Silver Lake, IN 46982 U.S.A.
FAX: 260-352-2160

maintenance:

Regular inspection and maintenance of all parts, and fasteners is necessary. Tighten all bolts and nuts. Inspect Tops, Seats, Legs, Braces and Fasteners periodically for wear or vandalism. Replace broken or worn parts immediately or take equipment out of service until repairs are made. Use genuine Wabash Valley replacement parts.

To restore plastisol coating to its luster after prolonged use, wash/rinse/dry and use Armor-All ® or similar quality vinyl protectant.

KEEP THIS ASSEMBLY/SPECIFICATION SHEET FOR FUTURE REFERENCE.

specifications:

NOTE: We reserve the right to change specifications without notice.

Heat fused poly-vinyl coating, finished on inner-metal structure, to an approximate 3/16" thickness. Framework assemblies are finished with powder coating; electrostatically applied and oven cured according to powder manufacturer's specifications. Fasteners are stainless steel to resist corrosion.

BENCH LEG:

Leg with and with out arm is constructed of 1 5/8" od x 12 gage structural steel tubing. Foot pads are 10 gage sheet steel.

BENCH SEAT:

Expanded metal seat uses fabricated 3/4" #9 steel. Rib uses 10 gage and perforated seats use 12 gage sheet steel. Slats are 3/16" x 2 1/4" flat bar. The bench's frame/mounting brackets are 10 gage sheet steel. The ends of the rolled side use 1/4" x 1 1/4" steel flat bar for support.

GENERAL:

4' Uptown bench ground space requirements are 28 7/8" x 51 1/8". The bench seat is 48 1/8" long x 25 1/2" wide and 17 3/4" to the top of the lowest part of the bench's seat.

6' Uptown bench ground space requirements are 28 7/8" x 75 1/8". The bench seat is 72 1/8" long x 25 1/2" wide and 17 3/4" to the top of the lowest part of the bench's seat.

parts identification:

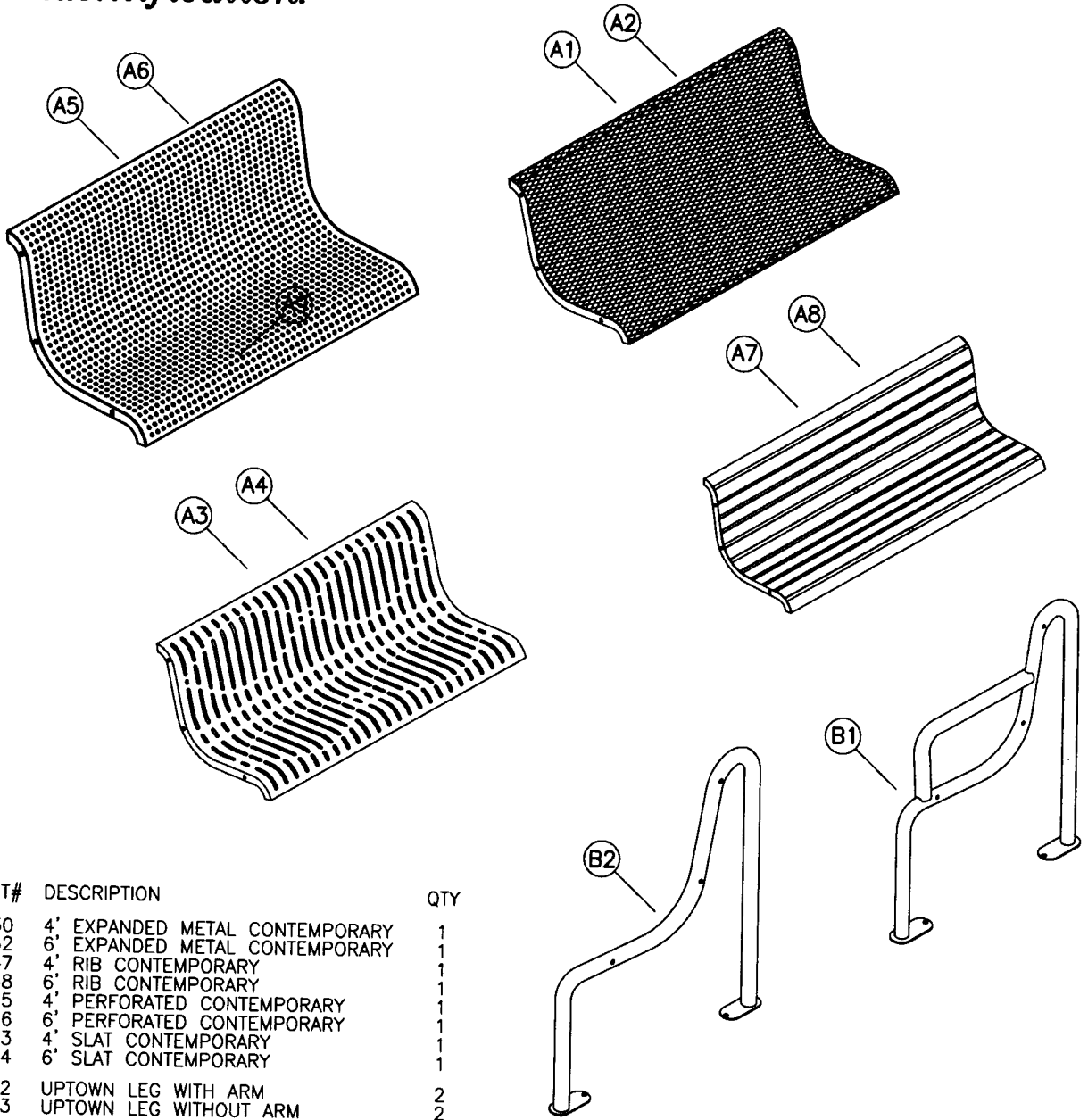

ITEM	PART#	DESCRIPTION	QTY
A1	7930	4' EXPANDED METAL CONTEMPORARY	1
A2	7862	6' EXPANDED METAL CONTEMPORARY	1
A3	7947	4' RIB CONTEMPORARY	1
A4	7948	6' RIB CONTEMPORARY	1
A5	8015	4' PERFORATED CONTEMPORARY	1
A6	8016	6' PERFORATED CONTEMPORARY	1
A7	8153	4' SLAT CONTEMPORARY	1
A8	8154	6' SLAT CONTEMPORARY	1
B1	7492	UPTOWN LEG WITH ARM	2
B2	7493	UPTOWN LEG WITHOUT ARM	2

DRAWINGS NOT TO SCALE

hardware identification:

ASSEMBLY TOOLS REQUIRED

- 1 - REGULAR TIP SCREWDRIVER
- 2 - 1/2" WRENCHES
- 1 - 3' OR 6' LEVEL

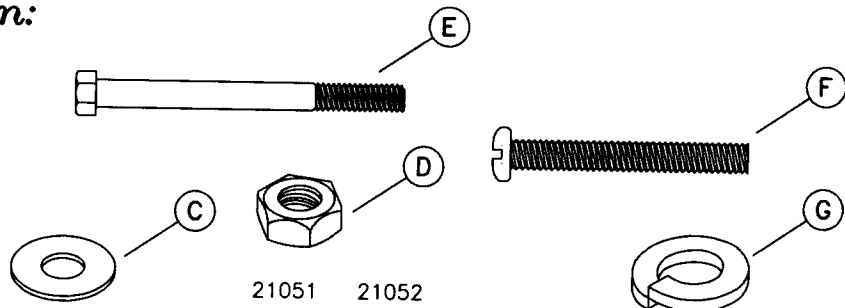

ITEMS INCLUDED IN HARDWARE PACKAGE#

ITEM	PART#	DESCRIPTION	21051 QTY	21052 QTY
C	17028	3/8" FLAT WASHER - SS	6	6
D	17032	5/16-18 HEX FINISH NUT - SS	6	6
E	17053	5/16-18 x 3 1/2" HEX HEAD BOLT - SS	0	3
F	17033	5/16-18 x 2 1/2" MACHINE SCREW - SS	6	0
G	17050	5/16" SPLIT LOCK WASHER - SS	6	0

assembly procedures:

IMPORTANT: Assemblers should be reasonably skilled in the assembly of commercial grade/heavy duty fabricated steel equipment.

To ensure proper assembly, it is suggested that you take adequate time to locate and identify each part. To prevent scratching of the finished pieces, we recommend this unit to be assembled on a clean, flat, solid, surface with a drop cloth, allowing plenty of working room. **Also please read the instructions and study the sketches very carefully.** A little extra time spent before assembly will be well worth it in performing a complete, proper assembly. Please note that all parts have been pre-cut and pre-drilled.

During the assembly process leave all bolts and nuts "finger tight", until the entire unit is completely assembled. This allows room for movement to level or adjust all seats, tops, benches, framework and braces if necessary. **After final adjustment and leveling, permanently tighten all nuts, bolts and fasteners.**

76

STEP 1:

Stand one (B1 or B2) leg upright on its feet. Lift upward on the arm and pivot on the rear foot pad until the leg is lying on its back, see FIG. 1. Be sure to prop leg on both sides to prevent tipping. Place (A-) seat next to the leg and rotate upward to match position of leg.

STEP 2:

Align holes of the seat's frame/mounting bracket to the holes on the leg. Use three (F) and (D) with one (C) and (G) per (F). NOTE: Washers (C) and (G) must be used on the seat side.

STEP 3:

Repeat STEP 1 and STEP 2 to complete installation on the other end of the seat.

STEP 4:

Finger tighten the bolts and rotate the bench legs to its original position in STEP 1. Level the bench if necessary. Tighten the bolts with proper wrenches.

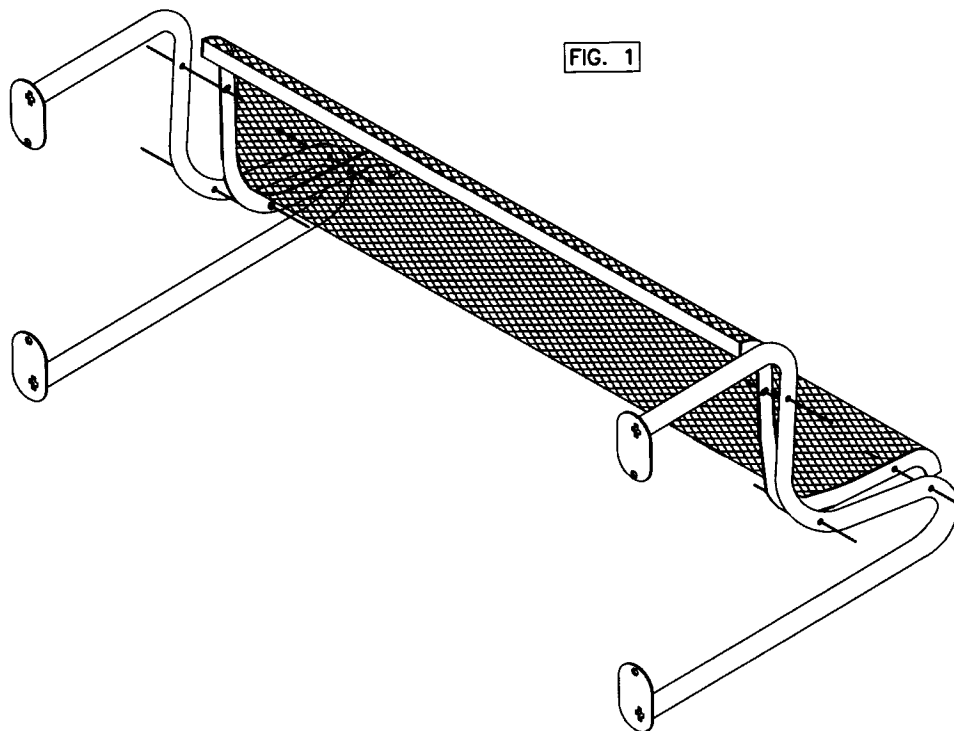
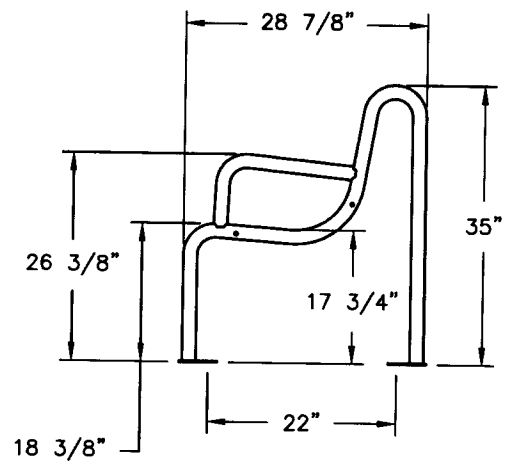
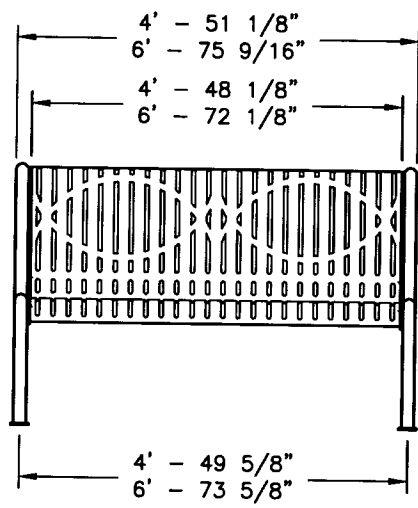

FIG. 1

installation: **WARNING:** The proper installation for Wabash Valley products may depend upon many factors unique to the site, location, or use of a particular product. Consult with your contractor or other professional to determine your specific installation requirements.

product dimensions:



Part IX -Technical Specifications

02270 – Erosion Control

02535B – Color Coating, Tennis

02613A - Court Surface Paving

02711- Chain Link Fences

02831 – Chain Link Fence and Gates –PVC Coated

02870 – Site Specialties

SECTION 02270 – EROSION CONTROL

Part 1—General

Part 2—Products

Part 3—Execution

A. PART 1—GENERAL

Work Included

- A. Installation of erosion control devices as per local, state, and/or federal storm water pollution prevention requirements.
- B. Maintenance of such devices during the construction period.
- C. Maintenance of records regarding the installation.
- D. Removal of erosion control devices at the appropriate time when construction and seeding work is complete.

Related Work Specified Elsewhere

- A. Section 02215, Finish Grading

Measure and Payment

- A. All erosion control measures are a part of the lump sum base bid. For additional requested measures beyond the original scope, payment shall be negotiated as per the unit costs outlined on Attachment #5, List of Unit Prices, within this contract.

Submittals

- A. If requested, submit interim reports and data as may be required by governing agencies.

Quality Assurance

- A. **Qualifications:** All Contractors or Subcontractors performing work under this section shall be qualified to do such work and hold the appropriate registration, license, or other permit as required by state or local law.
- B. **Requirements of Regulatory Agencies:** Contractor shall procure all permits and licenses, pay all charges and fees, and give all notice necessary and incidental to the due and lawful prosecution of work.

Job Conditions

- A. **Site Inspection:** Contractor shall familiarize him/herself with the site, the plans, the specifications and plan requirements and is responsible to call any discrepancies or potential problems to the attention of the Owner.
- B. **Protection:** Carefully maintain all bench marks, construction stakes, monuments, or other reference points. If any are disturbed or destroyed, replace as directed.
- C. **Coordination:** Contractor shall coordinate with the clearing and grading Subcontractor(s) to ensure the timely installation of required items and the maintenance or repair of the same.

Inspection

- A. Owner may make periodic site visits to inspect erosion control devices. If erosion control devices are not being properly installed and maintained, a written notice will be issued.
- B. The work site is also subject to inspection by governing bodies having jurisdiction. Such inspections may be without notice and the Contractor will be subject to any penalties as may apply.
- C. The Contractor shall inspect all erosion control devices on a weekly basis and within 24 hours of all storm events that produce $\frac{1}{2}$ " or more of rain within a 24 hour period. All defects discovered by these inspections shall be repaired within 24 hours.

B. PART 2—PRODUCTS

I. Materials

- A. Materials shall be as required by the governing agencies having jurisdiction and by the specifications. The more stringent shall apply.

C. PART 3—EXECUTION

Installation

- A. Use sediment control Filtrex, Siltsoxx or equal along the perimeter of grading activities as shown on plans.
- B. Protect newly graded areas from erosion.
- C. Repair settlement and erosion that occurs prior to acceptance of work.
- D. Use stone check dams in place of straw bales where shown on the plans. See plans for detail of stone check dams.
- E. Protect curb inlets with rock bags or equal.

Maintenance and Repair

- F. Perform periodic maintenance on sediment fence to remove sediments, re-stake knocked-down fencing, and reinforce with straw bales as necessary to protect downstream drainage systems from sediment.

Removal

- G. Remove erosion control devices at the appropriate time upon completion of construction and seeding and in accordance with all applicable governmental agencies.
- H. Finish grade areas where such devices have been removed. Seed or otherwise landscape the areas to match those adjacent and in accordance with the drawings.
- I. Follow specifications for seeding.

Cleanup

- J. Upon completion of the work, the Contractor shall leave the area in a neat and presentable condition acceptable to the Owner.

END OF SECTION

SECTION 02535B - COLOR COATING, TENNIS (New surface)

PART 1—SURFACE PREPARATION-ASPHALT

- A. New asphalt shall be allowed to cure at least 30 days, or until free of light oils and presents a water break-free surface before application of surfacing materials. The water break consists of casting one or two gallons of clean water from a suitable, clean container, such as a 5 gallon pail, out onto the surface of the court. The water should sheet out across the surface without ribboning, crawling or showing oil rings (comparable to water on very clean glass vs. dirty or greasy glass). If the clean water does not wet the surface uniformly, the asphalt is not ready for coating and shall age longer.
- B. Surface shall be clean and free of all dust, dirt, debris, weeds, grease, oil and other foreign matter. Clean by washing with high pressure water or by vacuuming or power blower. Wet scrub low areas with water and stiff broom to remove all sediment and silt.
- C. Lines are to be taped before applying line paint. No knives shall be used to cut tape.

PART 2—APPLICATION

Color surfacing shall be applied to the clean, prepared surface to obtain a total application rate per the manufacturer's specifications. The first three (3) coats shall be latex acrylic filler/resurfacer to fill depressions or irregularities, followed by two(2) coats of latex color coating applied per manufacturer's specifications. Material shall be thoroughly cured before being covered by a succeeding application. Method of applying is spreading material from windrow using a flexible rubber squeegee. Or, spreading with squeegee and leveling with a roller-coater, rolling at a right angle to the squeegee pull. Wet material in the windrow shall not be allowed to dry during application. Courts are to have a minimum of three coats. More coats may be needed to insure smooth finish.

PART 3-PRODUCTS

- A. Latex-ite Acrylic Resurfacer or approved equal. Must be compatible with color coating.
- B. Latex-ite Color coating system or approved equal. Contractor must submit manufacturer's specification for product and application rates.
- C. Latex-ite Line Paint or approved equal.

PART 3—PLAYING LINES

After the color finish course has cured twenty-four to forty-eight (24-48) hours, playing lines two inches (2") wide conforming to United States Tennis Association specifications shall be accurately located, marked and painted with line paint. Twenty-four (24) hours drying time shall be allowed before recreational use. Apply two coats minimum.

PART 4—LIMITATIONS

Application of coating materials shall not be permitted during rainfall, when rainfall is imminent and/or unless air temperature is at least fifty degrees Fahrenheit (50°) and rising. **DO NOT ALLOW TO FREEZE.**

PART 5—CLEAN-UP

Clean water should be used to wash tools immediately after application.

Note: Product specifications "of equal" products must be submitted with bid

END OF SECTION

SECTION 02613A - COURT SURFACE PAVING

- Part 1—General
- Part 2—Materials
- Part 3—Execution

PART 1—GENERAL

A. Quality Assurance

1. **Qualifications of Asphalt Concrete Producer:** Use only materials which are furnished by a bulk asphalt concrete producer regularly engaged in production of hot-mix, hot-laid asphaltic concrete.
2. **Grade:** Contractor shall produce final surfaces of uniform texture conforming to required grades and cross sections.
3. **Thickness:** In-place compacted thickness will not be acceptable if exceeding following allowable variation from thickness shown on drawings.
 - Base course: 1 ½", +/-
 - 1 ¼ surface asphalt with aramid fibers
 - Surface course: 1 ½", +/-
 - 1 ¼ surface asphalt with aramid fibers
4. **Smoothness:** Test finished surface of each asphalt course for smoothness, using a 10' straight edge applied parallel to, and at right angles to, center line of paved areas. Surfaces will not be acceptable if exceeding 1/4" deviation in 10'. The only exception will be crowned surfaces which are to be crowned smoothly.

B. Job Conditions

1. **Weather Limitations**
 - a. Apply asphalt base course when ambient temperature in the shade is above 35° F. and when temperature has not been below 35° F. for 12 hours immediately prior to application.
 - b. Do not apply when existing asphalt surface is wet or contains moisture that would prevent uniform distribution and penetration.
 - c. Construct asphalt surface course only when air temperature is above 40° F. and when base course is dry and weather is not rainy.
2. **Grade Control**

Establish and maintain the required lines and grades, including crown and cross-slope, for each course during construction operations.
3. **Traffic Control**
 - a. Maintain vehicular and pedestrian traffic during paving operations, as required for other construction activities.
 - b. Provide flagmen, barricades, warning signs, and otherwise fulfill traffic control requirement of the KY D.O.T. when working on or near public right-of-way.
4. **Site Maintenance & Restoration**
 - a. Site must be maintained during construction in such a manner as to provide for the safety of the public and the security of the property from damage.

- b. Access routes for all construction vehicles must be approved by Owner prior to beginning construction.
- c. Any and all damage to site, including but not limited to, existing structures, grass areas, concrete or other paving, and fencing, must be restored to a condition acceptable to the owner.

PART 2—MATERIALS

Tack Coat Emulsion

Asphaltic Concrete

- 1 ½" binder asphalt
- 1 ¼" surface asphalt with aramid fibers
- 1 ½" surface asphalt
- 1 ¼" surface asphalt with aramid fibers

Gravel Aggregate

- 6" compacted of #57 limestone w/fines (non-washed)

PART 3—EXECUTION

A. Surface Preparation

1. **Remove existing asphalt surface:** Remove and dispose of all existing asphalt to gravel base.
2. **Loose and foreign material:**
 - a. Remove any soft areas of existing DGA base and replace with new DGA.
 - b. Add DGA as needed to maintain a 6" base of compacted DGA. Grade should be leveled using a laser grader.

B. Preparing the Mixture

1. Comply with locally acceptable conditions for storage, control, and mixing.
2. Use of Aramid fibers must meet manufacturers mixing specifications.
3. **Stockpiles**
 - a. Keep each component of the various sized combined aggregates in separate stockpiles.
 - b. Maintain stockpiles so that separate aggregate sizes will not be intermixed.
3. **Heating**
 - a. Heat the asphalt cement at the mixing plant to viscosity at which it can be uniformly distributed throughout mixture.
 - b. Use lowest possible temperature to suit temperature-viscosity characteristics of asphalt.
 - c. Do not exceed 350° F. (176.6° C.)
4. **Aggregate**
 - a. Heat-dry aggregates to reduce moisture content to not more than 1.0%.
 - b. Deliver dry aggregate to mixer at recommended temperature to suit penetration grade and viscosity characteristics of asphalt cement, ambient temperature, and workability of mixture.
 - c. Accurately weigh or measure dry aggregates and weigh or meter asphalt cement to comply with job-mix formula requirements.
5. Mix aggregate and asphalt cement to achieve 90-95% of coated particles for base mixtures and 85-90% of coated particles for surface mixtures.
6. **Transporting**

- a. Transport asphalt concrete mixtures from mixing site in trucks having tight, clean compartments.
- b. Coat hauling compartments with a lime-water mixture to prevent asphalt concrete mixture from sticking.
- c. Elevate and drain compartment of excess solution before loading mix.
- d. Provide covers over asphalt concrete mixture when transporting to protect from weather and to prevent loss of heat.
- e. During periods of cold weather or for long-distance deliveries, provide insulation around all truck bed surfaces.

C. Equipment

1. Provide size and quantity of equipment to complete the work specified within project time schedule.

D. Bituminous Pavers

1. Self-propelled that spread hot asphalt concrete mixtures without tearing, shoving, or gouging surfaces, and control pavement edges to true lines without use of stationary forms.

E. Rolling Equipment

- a. Self-propelled that spread hot asphalt concrete mixtures without tearing, shoving, or gouging surfaces, and control pavement edges to true lines without use of stationary forms.
- b. Other type rollers may be used if acceptable to the Owner.
- c. Roller shall be a minimum of 10 tons.

F. Hand Tools

Provide rakes, lutes, shovels, tampers, smoothing irons, pavement cutters, portable heaters, and other miscellaneous small tools to complete the work specified.

PART 4 - Placing the Mix

1. Place asphalt concrete mixture on prepared surface, spread and strike-off using paving machine.
2. Spread mixture at a minimum temperature of 225° F. (107.2° C.)
3. Inaccessible and small areas may be placed by hand.
4. Place each course at thickness so that when compacted it will conform to the grade, cross-sections, finish thickness, and density indicated.

5. Paver Placing

- a. Unless otherwise directed, begin placing along centerline of areas to be paved on crowned section, and at high side of sections on one-way slope, and in direction of traffic flow.
- b. After first strip has been placed and rolled, place succeeding strips and extend rolling to overlap previous strips.
- c. Complete base courses for a section before placing surface courses.
- d. Place mixture in continuous operation as practicable.

6. Hand Placing

- a. Spread, tamp, and finish mixture using hand tools in areas where machine spreading is not possible.
- b. Place mixture at a rate that will ensure handling and compaction before mixture becomes cooler than acceptable working temperature.

7. Joints

- a. Carefully make joints between old and new pavements, or between successive days' work, to ensure a continuous bond between adjoining work.
- b. Construct joints to have same texture, density, and smoothness as adjacent sections of asphalt concrete course.
- c. Clean contact surfaces free of sand, dirt, or other objectionable material and apply tack coat.
- d. Offset longitudinal joints in succeeding courses not less than 6 in.
- e. Cut back edge of previously placed course to expose an even, vertical surface for full course thickness.
- f. When the edges of longitudinal joints are irregular, honeycombed, or inadequately compacted, cut back unsatisfactory sections to expose an even, vertical surface for full course thickness.

PART 5 - Compacting the Mix

1. Provide sufficient rollers to obtain the required pavement density and smooth seams. Ten ton minimum roller. Poor density of seams will not be accepted.
2. Begin rolling operations as soon after placing as the mixture will bear weight of roller without excessive displacement.
3. Do not permit heavy equipment, including rollers, to stand on finished surface before it has thoroughly cooled or set.
4. Compact mixture with hot hand tampers or vibrating plate compactors in areas inaccessible to rollers.
5. Start rolling longitudinally at extreme lower side of sections and proceed toward center of pavement. Roll to slightly different lengths on alternate roller runs.
6. Do not roll centers of sections first under any circumstances.
7. **Breakdown Rolling**
 - a. Accomplish breakdown or initial rolling immediately following rolling of transverse and longitudinal joints and outside edge.
 - b. Operate rollers as close as possible to paver without causing pavement displacement.
 - c. Check crown, grade, and smoothness after breakdown rolling.
 - d. Repair displaced areas by loosening at once with lutes or rakes and filling, if required, with hot loose material before continuing rolling.

8. Second Rolling

- a. Follow breakdown rolling as soon as possible, while mixture is hot and in condition for compaction.
- b. Continue second rolling until mixture has been thoroughly compacted.

9. Finish Rolling

- a. Perform finish rolling while mixture is still warm enough for removal of roller marks.
- b. Continue rolling until roller marks are eliminated and course has attained specified density.

PART 6 - Cleaning and Protection

1. Cleaning

After completion of paving operations, clean surfaces of excess spilled asphalt materials to the satisfaction of Owner.

2. Protection

- a. After final rolling, do not permit vehicular traffic on asphalt concrete pavement until it has cooled and hardened, and in no case sooner than 12 hours.
- b. Provide barricades and warning devices as required to protect pavement and the general public.
- c. Cover openings of structures in the area of paving until permanent coverings are placed.

NOTE: All equals to be submitted to the Park Designer 48 hours prior to the bid opening.

END OF SECTION

SECTION 02711 - CHAIN LINK FENCES

- Part 1—General
- Part 2—Products
- Part 3—Execution
- Part 4—Cleanup

PART 1—GENERAL

D. Scope - The work covered by these specifications includes the furnishing of all labor, equipment, appliances, transportation and materials required for the installation and/or erection of fences, gates, and related items as drawn or herein specified.

E. Quality Assurance- Erector Qualifications: Minimum of two years' experience installing similar fencing.

Product Delivery, Storage and Handling

1. Deliver materials with manufacturer's tags and labels intact.
2. Handle and store to avoid damage.

PART 2—PRODUCTS

A. Chain Link Fabric

1. Shall conform to Federal specifications RR-F 191A.
2. Type A, 2" square mesh fabric.
3. Top edges knuckled.
4. #9 gage wire, conforming to ASTM 342-1, Class 1.

B. Posts, Top rail, Braces, Gate Frames and Backstop Mid-rails

1. Shall be standard O.D., SS40 pipe.
2. Base Metal - shall be steel of such quality that the fabricated product will meet the performance criteria set forth in this standard. The steel strip used in the manufacture of the pipe shall conform to ASTM A-569.
3. Zinc - used in the manufacture of flo-coat pipe and shall conform to ASTM B-6 High Grade and Special High Grade Zinc.
4. Clear Coating - shall be manufactured from high grade raw materials which produce a cross-linked acrylic polyurethane coating.
5. Internal Coating - shall have a minimum zinc power loading of 87% by weight and be capable of providing galvanic protection.
6. Mid-rails on backstops to be welded to posts.

C. Technical

1. Weight of Zinc Coatings - shall be determined by the method contained in ASTM A-90.
2. Chromate Coating Weight - shall be 30 micrograms/sq. in.
3. Exterior Clear Coated Surface - shall have a demonstrated ability to resist 1000 hours of exposure to salt fog with a maximum of 5% red rust when conducted in

accordance with ASTM-B117.

D. Performance Properties of the Product

1. The strength of line, end, corner and pull posts shall be determined by a 6-foot cantilever beam test.
2. The strength of top rail shall be determined by using a 10' tree supported beam test.

	Diameter	SS40st/ft	6' Cantilever
Line posts, gate post	2-1/2"	3.117 lbs	330 lbs
End, corner, gate post	3"	4.640 lbs	610 lbs
*Top rails	1-5/8"	1.836 lbs	135 lbs
*Braces	1-5/8"	1.836 lbs	135 lbs
*Gate frames	1-5/8"	1.836 lbs	135 lbs

*Note: 10' support load 327 lbs. All pipe materials shall be prime, no welds or "reject" pipe. Letter of "Mill Certification" shall be provided on pipe.

- E. Provide approved malleable post tops, sleeves, and other fittings for complete installation. All such frame work shall be hot-dip, zinc-coated after fabrication.

PART 3—EXECUTION

A. Inspections

1. Verify that final grading in fence location is completed without irregularities which would interfere with fence installation.
2. Do not commence work until unsatisfactory conditions have been corrected.

B. Installation

1. Posts shall be buried in concrete cylinders to a minimum depth of 27" to 30" of concrete.
2. Concrete cylinders shall have the following minimum diameter:

Line posts	9"
Corner posts	12"
Gate posts	12"

3. Where installed through asphalt paving, the top of the cylinders shall be flush with the surface of the asphalt. Top of the cylinder shall be troweled to a smooth surface.
4. Unless otherwise indicated, posts shall be spaced not more than 10 feet apart.
5. Fabric to be tied every foot.

PART 4—CLEANUP

- A. All rough edges, tags and staples to be removed.
- B. Site is to be left free of all trash and debris.

Note: All equals to be submitted to the Park Designer 48 hours prior to the bid opening.

END OF SECTION

SECTION 02831 - CHAIN LINK FENCES AND GATES – PVC coated

- Part 1—General
- Part 2—Products
- Part 3—Execution
- Part 4—Cleanup

PART 1 - GENERAL

1.01 WORK INCLUDED

- A. The work covered by these specifications includes the furnishing of all labor, equipment, appliances, transportation and materials required for the installation and/or erection of PVC coated fences, gates, and related items as drawn or herein specified.

1.02 RELATED WORK SPECIFIED ELSEWHERE

1.03 REFERENCES/STANDARDS

- A. Where American Society for Testing and Materials (ASTM) standards are referenced, they are made a part of this Section unless otherwise noted. Such standards shall be the current issues and standards.

1.04 SUBMITTALS

- A. Shop Drawings: Include complete details of fence and gate construction, fence height, chain link fabric gauges, post spacing, dimensions and unit weights of framework, and concrete footing details. Actual samples and certificates of compliance may be requested.

1.05 QUALITY ASSURANCE

- A. Qualifications: Contractors or subcontractors performing work under this Section shall be qualified to do such work and hold the appropriate registration, license, or other permit as required by state or local law.
- B. Requirements of Regulatory Agencies:
 - 1. Contractor shall procure all permits and licenses, pay all charges and fees, and give all notices necessary and incidental to the due and lawful prosecution of the work.
 - 2. Contractor shall comply with all code requirements.

1.06 JOB CONDITIONS

- A. Site Inspection: Contractor shall familiarize him/herself with the site, the plans, the specifications, special provisions, and plan requirements, and is

responsible for calling any discrepancies or special problems to the attention of the Division of Parks & Recreation Representative.

B. Protection:

1. Protect, maintain, and restore bench marks, monuments, and other reference points affected by this work. If such items are displaced or destroyed by this work, they will be reestablished by a licensed surveyor at no expense to the Owner. After items have been permanently set, certify the work and furnish certification to the Owner's Representative

C. Coordination

1. Contractor shall coordinate with Owner or Owner's representative prior to commencement of work.
2. Contractor shall coordinate with other trades affected by the work.

D. Sequencing/Scheduling: Contractor shall keep him/herself informed of the construction progress of all other Contractors and/or subcontractors working on the project, particularly where they affect his/her work, and shall coordinate his/her work with that of other Contractors to ensure efficient and orderly progress of the work.

E. Surveyor: Contractor shall provide the services of a registered surveyor to lay out the graded area and check the grades during the progress of the work.

F. Construction Stakes

1. Construction stakes shall be set to mark the general location, alignment, elevation, and grade of the work. The Contractor shall assume full responsibility for dimension and elevations from such stakes.
2. The Contractor shall furnish at his/her expense the size, quality, and quantity of stakes required.

1.07 WARRANTIES/GUARANTEES

A. For a period of one year from the date of issuance of the Final Certificate of Payment for the work, the Contractor shall furnish and install, without cost to the Owner, any and all work which, in the judgment of the Owner, proves defective in materials and/or workmanship.

PART 2 - PRODUCTS

2.01 MATERIALS

A. Framework: Type I or Type II Steel Pipe.

1. Type I – Schedule 40 steel pipe with 1.8 ounces of zinc coating per square foot of surface area conforming to Standard Specification ASTM F1083 ; or,
2. Type II – Pipe manufactured from steel conforming to ASTM A669, Group IC, cold-rolled, having minimum yield strength of 55,000 psi and coated with a total of 0.9 ounces of zinc per square foot on the internal and external surfaces meeting the coating requirements of ASTM A525G90. A minimum of 15 micrograms of zinc chromate per square inch and a minimum of 3 mils of lifecoat fuse bonded polyester powder exterior coating.
3. All coatings to be applied inside and out after welding.
4. Pipe shall be straight, true to section, and conform to the following weights:

Pipe Size Outside Diameter	Type I Weight Lbs./FT	Type II Weight Lbs./Ft
1-5/8"	2.27	1.84
2"	2.72	2.28
2-1/2"	3.65	3.18
3"	5.79	4.65
3-1/2"	7.58	5.71
4"	9.11	6.56
6-5/8"	18.97	

5. Piping to be black in color.

B. Fabric – PVC Coated

1. Fabric shall be either 6 gauge steel core, 9 gauge steel core wire, or as specified by Owner prior to request for quote.
2. Coating to be .015-.025 PVC bonded to galvanized wire.
3. Fabric to be black in color.

2.02 CONCRETE MIX

- A. ASTM C94 Portland cement concrete with maximum ¾ inch aggregate having a minimum compressive strength of 3,000 psi at 28 days.

2.03 COMPONENTS

- A. Fence Posts:

Type I-II

Fabric Height	Line Post O.D.	Terminal Post O.D.	Nominal Pipe Size
Under 6'	2"	2 1/2"	2"
6' to 9'	2 1/2"	3"	2 1/2"
9' to 12'	3"	4"	3 1/2"
20' to Backstop	4"	6"	3 1/2"

B. Gate Posts:

Single Gate Width	Double Gate Width	Post O.D. Type II	Nominal Pipe Size
Up to 6'	Up to 12'	3"	2 1/2"
7' to 12'	13' to 25'	4"	3 1/2"

C. Rails and Braces: 1-5/8 inches O.D. (nominal pipe size 1- 1/4 inch).

D. Gates: Frame assembly of 2 inch O.D. pipe Type I or Type II with welded joints. Weld areas repaired with zinc-rich coating applied per manufacturer's directions. Fabric to match fence. Gate accessories, hinges, latches, center stops, keepers and necessary hardware of quality required for industrial and commercial application. Latches shall permit padlocking.

E. Fittings:

1. Post Caps – Pressed steel, cast iron or cast aluminum alloy designed to fit snugly over posts to exclude moisture. Supply cone type caps for terminal posts and loop for line posts. All fittings to conform to ASTM F626.
2. Rail and Brace Ends – Pressed steel, cast iron, or cast aluminum alloy, cup-shaped to receive rail and brace ends.
3. Top Rail Sleeves – Tubular steel, 0.051 inch thickness x 7 inches x 7 inches long, expansion type.
4. Tension Bars – Steel strip, 5/8 inch wide x 3/16 inch thick.
5. Tension Bands – Pressed steel, 14 gauge thickness x 3/4 inch wide.
6. Brace Bands – Pressed steel, 12 gauge thickness x 3/4 inch wide.
7. Truss Rods – Steel rod, 3/8 inch diameter merchant quality with turnbuckle.

F. Tension Wire: Marcellled 7 gauge steel wire with minimum coating of 0.80 ounces of zinc or 0.40 ounces of aluminum per square foot of wire surface and conforming to ASTM A824.

G. Tie Wire: Aluminum, 9 gauge, alloy 1100-H4 or equal.

- H. Hog Rings: Steel wire, 11 gauge, with a minimum zinc coating of 0.80 ounces per square foot of wire surface.
 - I. All fencing and piping components to be black in color.
- 2.04 FOUL POLES
- A. Supply and install foul poles as per the Drawings.
- 2.05 PRIMER AND PAINT FOR FOUL POLES
- A. Exterior grade, oil-based, as manufactured by Glidden, Sherwin-Williams, or other approved equivalent, in yellow color.

PART 3 EXECUTION

3.01 INSTALLATION

- A. General: Installation to conform to ASTM F567
- B. Height: Provide height as indicated on construction documents.
- C. Post Spacing: Spacing of line posts at intervals not exceeding 10 feet.
- D. Post Setting: Set terminal, gate, and line posts plumb in concrete footings. Top of footing to be flush with grade and sloped to direct water away from posts.
- E. Bracing: Brace gate and terminal posts back to adjacent line posts with horizontal brace rails and diagonal truss rods.
- F. Top Rail: Install through line post loop caps connecting sections with sleeves to form a continuous rail between terminal posts.
- G. Top Tension Wire: When a top rail is omitted, stretch tension wire through loop caps and fasten to terminal posts.
- H. Bottom Rail: Run bottom rail flush to grade continuous along all fencing.
- I. Fabric: Pull fabric taut with bottom selvage $\frac{1}{2}$ inch grade. Fasten to terminal posts with tension bars threaded through mesh and secured with tension bands at maximum 15 inch intervals. Tie to line posts and top rails with tie wires spaced at maximum 12 inches on posts and 24 inches on rails. Attach to bottom tension wire with top rings at maximum 24 inch intervals.
- J. Gates: Install gates plumb, level, and secure for full opening without interference. Anchor center stops and keepers in concrete.
- K. Fasteners: Install nuts for fittings, bands, and hardware bolts on side of fence opposite baseball playing field on interior fences, and inside of fence at main entry gate and maintenance access gate.
- L. All rails, posts, and connectors will be located outside the ball playing fields.

3.02 CLEANUP

Upon completion of the work, Contractor shall remove from the site any excess construction materials, trash, or other items, leaving the site in clean and finished condition acceptable to the Owner and governmental authorities having jurisdiction.

END OF SECTION

SECTION 02870 - SITE SPECIALTIES

PART 1—GENERAL

- A. Install all miscellaneous specialties and necessary items to complete the work required by the plans and herein specified.

PART 2—PRODUCT

- A. Tennis nets: MacGregor Super Pro 5000.
- B. Net posts: Douglas Industries, Inc. EZ Tennis Post item #63031-black. 3441 S 11th Ave. Eldridge, IA 52748, 800-553-8907.

PART 3—EXECUTION

- A. Installation – Assemble and install per plans and manufacturers specifications.
- B. Cleanup - Site is to be left free of all trash and debris.

PART 4—CLEAN UP

- A. All rough edges, tags and staples are to be removed.
- B. Site is to be left free of all trash and debris.

NOTE: All equals must be submitted minimum of 48 hours prior to the bid opening for approval.

END OF SECTION

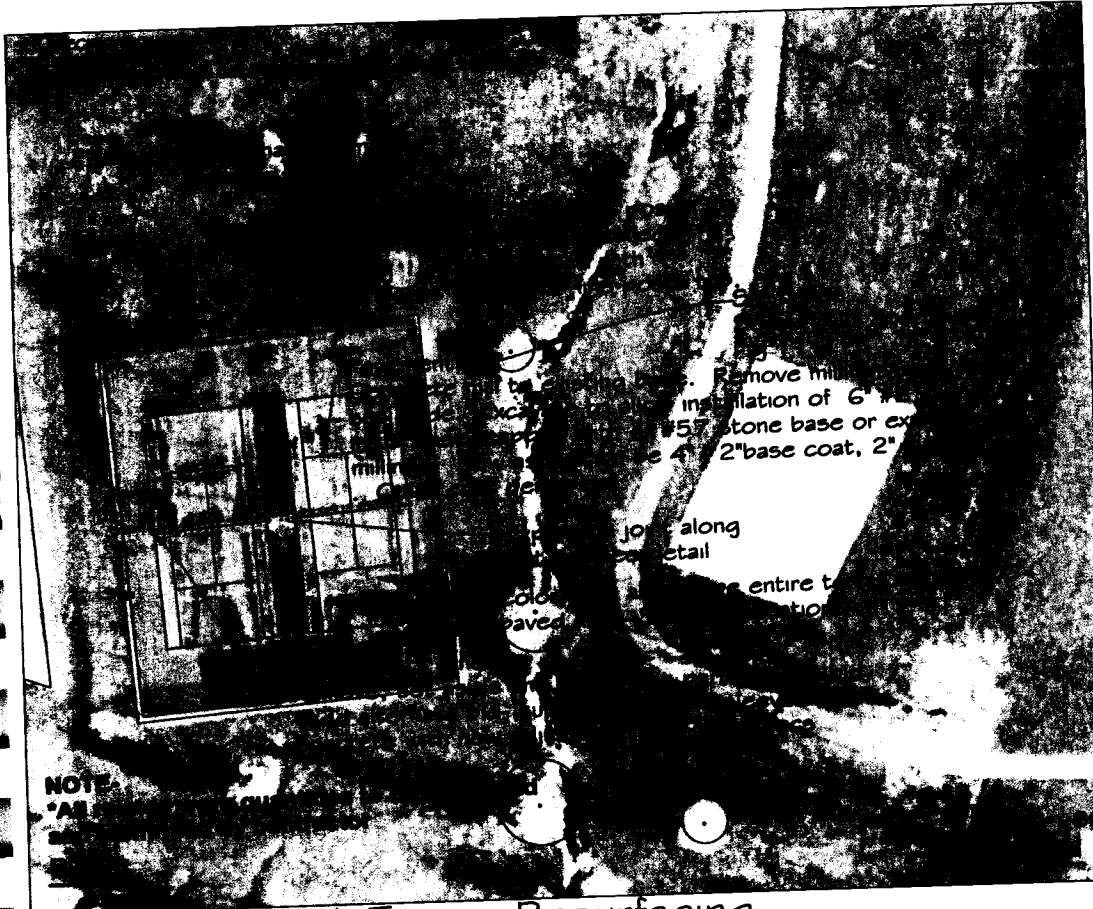

Notes:

1. Field verify all dimensions and grades.
2. Utilities shall be marked before any construction begins.
3. Site shall be kept clean and free of miscellaneous debris for the safety of park patrons.
4. All disturbed areas to be seeded and strawed upon completion of work.
5. Silt fence to remain in place until 90% cover is established- see fig 11-21 LFUCG Stormwater Manual

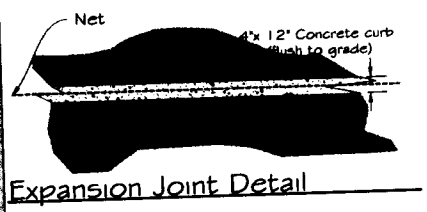

Expansion Joint Detail

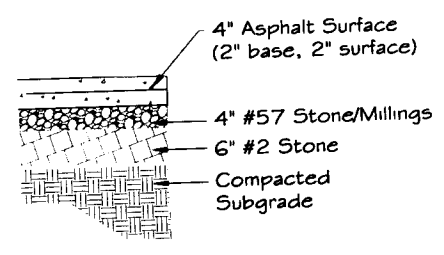

Pavement Detail

NOTE:
*All

Southland Park Tennis Resurfacing
LFUCG Division of Parks & Recreation

2015 Sept