

ORDINANCE NO. _____ - 2017

AN ORDINANCE AMENDING ARTICLES 1, 3, 8, 9, 10, 12, 15, 16, 17, 22A & B, 23, AND 24 OF THE ZONING ORDINANCE TO MOVE SEVERAL USES FROM THE CONDITIONAL USE CATEGORY TO EITHER THE PRINCIPAL PERMITTED OR THE ACCESSORY USE CATEGORY. (PLANNING COMMISSION).

WHEREAS, the Lexington-Fayette Urban County Planning Commission has considered a text amendment to Articles 1, 3, 8, 9, 10, 12, 15, 16, 17, 22A & B, 23 and 24 of the Zoning Ordinance to move several uses from the conditional use category to either the principal permitted or the accessory use category; and

WHEREAS, the Planning Commission did hold a public hearing on this proposed text amendment on July 27, 2017; and

WHEREAS, the Planning Commission did recommend APPROVAL of the text amendment by a vote of 10-1; and

WHEREAS, this Council agrees with the recommendation of the Planning Commission; and

WHEREAS, the recommendation form of the Planning Commission is attached hereto and incorporated by reference herein.

NOW, THEREFORE, BE IT ORDAINED BY THE COUNCIL OF THE LEXINGTON-FAYETTE URBAN COUNTY GOVERNMENT:

Section 1 – That Article 1 of the Zoning Ordinance of the Lexington-Fayette Urban County Government be and hereby is amended to read as follows:

GENERAL PROVISIONS AND DEFINITIONS

1-1 ADOPTION - This Zoning Ordinance, enacted by the Lexington-Fayette Urban County Government, is confirmed and adopted and reads as hereinafter set out.

1-2 SHORT TITLE - This Ordinance shall be known and may be cited as the "Zoning Ordinance."

1-3 PURPOSE - The purpose of this Zoning Ordinance is to implement the adopted Comprehensive Plan and other adopted Community Plans of Lexington-Fayette Urban County; to promote the public health, safety, morals, and general welfare; to facilitate orderly and harmonious development in the visual and historic character of Lexington-Fayette Urban County; to regulate the density of population and intensity of land use in order to provide for adequate light and air; to provide for vehicle parking and loading space; to improve the appearance of vehicular use areas and property abutting public rights-of-way; to require buffering between non-compatible land uses and to protect, preserve and promote the aesthetic appeal, character, and value of the surrounding neighborhoods; to promote public health and safety through the reduction of noise pollution, air pollution, visual pollution, air temperature, and artificial light glare; to further fair housing choice and the purposes behind the Federal Fair Housing Act(s); to facilitate fire and police protection; to prevent the overcrowding of land, blight, danger, and congestion in the circulation of people and commodities; to prevent the loss of life, health, or property from fire, flood, or other dangers; to protect airports, highways, and other transportation facilities, public facilities, including schools and public grounds, historic districts, central business districts, natural resources, and other specific areas of Lexington-Fayette Urban County which need special protection.

1-4 INTERPRETATION - In the interpretation and application of this Zoning Ordinance, the provisions herein shall be held to be the minimum or maximum requirements (as appropriate) adopted for the promotion of health, safety, morals, comfort, prosperity and general welfare. It is not intended by this Zoning Ordinance to repeal, abrogate, annul or in any way impair or interfere with any existing provisions of law, ordinance or resolution, or with any rules, regulations or permits previously adopted or issued, or which shall be adopted or issued pursuant to law relating to the use of buildings or premises, or with any private restrictions placed upon property by covenant, deed or

recorded plat; provided, however, where this Zoning Ordinance imposes a greater restriction upon the use of buildings or premises or upon the heights of buildings or requires greater lot areas, larger yards, or other open spaces than are imposed or required by such existing provisions of law, ordinance or resolution, or by such rules, regulations or permits, or by such private restrictions, the provisions of this Zoning Ordinance shall control.

1-5 CONFLICT OF ORDINANCE - Whenever these regulations, subdivision plats or development plans approved in conformance with these regulations are in conflict with other local ordinances, regulations or laws, the more restrictive ordinance, regulation, law, plat or plan shall govern and shall be enforced by appropriate local agencies. When subdivision and development plans, approved by the Planning Commission, contain setback or other features in excess of the minimum Zoning Ordinance requirements, such features as shown on the approved plan shall govern and shall be enforced by the responsible Division, as established by this Zoning Ordinance. Private deed restrictions or private covenants for a subdivision, which have not been approved by the Planning Commission and made a part of the approved subdivision plan, do not fall within the jurisdiction of enforcement by any local agency and cannot be enforced by the Lexington-Fayette Urban County Government.

1-6 PLANS AND CONSTRUCTION IN PROGRESS - To avoid undue hardship, nothing in this Zoning Ordinance shall be deemed to require change in the plans, construction, or designated use of any building or premises on which an application for a certificate or permit was filed with the Division of Building Inspection prior to the date of adoption of this Zoning Ordinance or amendment thereto, provided that the application meets all zoning and other requirements in effect on the date of said application. The issuance of said certificate or permit shall be valid only if it is exercised within one hundred and eighty (180) days from the date of issuance of the certificate or permit. "Exercised," as set forth in this section, shall mean that binding contracts for the construction of the main building or other main improvement have been let; or in the absence of contracts, that the main building or other main improvement is under construction to a substantial degree or that prerequisite conditions involving substantial investments shall be under contract, in development, or completed. When construction is not a part of the use, "exercised" shall mean that the use is in operation in compliance with the conditions as set forth in the permit or certificate.

1-7 REPARABILITY - If any clause, sentence, subdivision, paragraph, section or part of this Zoning Ordinance be adjudged by any court of competent jurisdiction to be invalid, such judgment shall not affect, impair or invalidate the remainder, thereof; but shall be confined in its operation to the clause, sentence, subdivision, paragraph, section or part thereof directly involved in the controversy in which said judgment shall have been rendered.

1-8 PLANNING COMMISSION - The Lexington- Fayette Urban County Planning Commission, created by Resolutions No. 1793 and 1797 of the City of Lexington and by Resolution of the Fiscal Court of Fayette County, and referred to prior to 1973 as the City-County Planning Commission, shall continue as the Planning Commission for Lexington-Fayette Urban County. There shall be eleven (11) members of the Planning Commission appointed by the Mayor, with approval of the Urban County Council for a term of four years, ending on July 1 of the designated year, with staggered terms so that the terms of two members of the Planning Commission expire each year. However, the members of the Planning Commission in office on the date of passage of this ordinance shall remain as members of the Planning Commission and shall serve until the expiration of the term to which they were originally appointed. All members shall be reimbursed for any necessary authorized expenses.

1-9 PLANNING UNIT AND JURISDICTION - The Planning Unit shall include all of the territory in Fayette County (also referred to as Lexington-Fayette Urban County or Lexington-Fayette County). The area of jurisdiction of the Planning Commission shall also include all of Fayette County.

1-10 STAFF - The staff of the Planning Commission shall be the Division of Planning in the Department of Administrative Services of the Lexington-Fayette Urban County Government.

1-11 DEFINITIONS - For the purpose of this Zoning Ordinance, certain terms are herewith defined. When not inconsistent with the context, words used in the present tense include the future; words in the singular number include the plural; words in the plural number include the singular; the word person includes association, firm, partnership, trust, governmental body, corporation, organization, as well as an individual; the word structure includes building; the word occupied includes arranged, designed or intended to be occupied; the word used includes arranged, designed or intended to be used; the word shall is always mandatory and not merely directive; the word may is permissive; and the word lot includes plot or parcel. Other words and terms shall have the following respective meanings:

ACCESSORY USE OR STRUCTURE - A use or a structure subordinate to the principal use or building on a lot and serving a purpose customarily incidental thereto. No accessory structure can be constructed on a lot before a principal structure.

ADAPTIVE REUSE - The process of adapting abandoned, vacant or underutilized buildings and structures for new purposes, which amounts to a change in the structure's primary purpose, a significant change in the way in which the structure is incorporated into and operates within the exterior environment, or which incorporates a non-traditional yet compatible combination of purposes or uses within the site plan. The adaptive reuse should incorporate changes that

rejuvenate and/or increase the sustainability of the site and/or neighborhood while retaining historic features of the original building(s) and/or structure(s).

ADULT ARCADE - Any place to which the public is permitted or invited, wherein coin-operated or slug-operated or electronically, electrically, or mechanically controlled still or motion picture machines, projectors, computers or other image producing devices are maintained to show images to five or fewer persons per machine at any one time; and where the images so displayed are distinguished or characterized by the depicting or describing of "specified sexual activities" or "specified anatomical areas" as herein defined.

ADULT BOOKSTORE OR ADULT VIDEO STORE - Any building or structure which contains or is used for the display or sale or rental of books, magazines, movie films, motion pictures, videos, computer disks and any and all printed or written materials, newspapers, photographic materials, drawings, novelties, other pictorial representations, devices and related sundry items which are distinguished or characterized by their emphasis on matters depicting, describing or relating to "specified sexual activities" or "specified anatomical areas" as herein defined; or an establishment with the segment or section devoted to the sale or display of such material.

ADULT CABARET - An establishment which features, as a principal use of its business, entertainers, waiters, or bartenders, either male or female, who expose to public view of the patrons of the establishment, at any time, the bare female breast below a point immediately above the top of the areola, human genitals, pubic region, or buttocks, even if partially or completely covered by translucent material; or human or simulated male genitals in a discernible turgid state, even if completely and opaquely covered.

ADULT DANCING ESTABLISHMENT - A business wherein employees, agents, servants or independent contractors perform dance routines offered as adult oriented entertainment for viewing by patrons and spectators on the premises, and characterized by an emphasis on "specified sexual activities" defined in this Article; or exposure of any part of the male or female anatomy otherwise prohibited by Section 3-26 of the Code of Ordinances.

ADULT DAY CARE CENTER - Any adult care facility, which provides part-time care, day or night, but less than twenty-four (24) hours, to at least four (4) adults who are not related to the operator by blood, marriage or adoption. The operator must be certified or licensed by a state public agency and may include personal care assistance, administering and/or assistance with medication, and social recreational activities.

ADULT ENTERTAINMENT ESTABLISHMENT - An "adult cabaret," "adult dancing establishment" or "sexual entertainment center."

AGRICULTURAL MARKET - A regulated place designated exclusively for the purpose of buying and selling of agricultural/farm products, including a stockyard; and to include aquaculture, horticulture, floriculture, viticulture, forestry, dairy, live- stock, poultry, bees, and any and all forms of farm products grown, raised or made by farm producers.

AGRICULTURAL USE - The use of a tract of land of at least five (5) contiguous acres for the production of agricultural or horticultural crops, including, but not limited to, livestock; livestock products; poultry; poultry products; grain; hay; pastures; soybeans; tobacco; timber; orchard fruits; vegetables; flowers or ornamental plants; including provision for dwellings for persons and their families who are engaged in the above agricultural use on the tract, but not including residential building development for sale or lease to the public.

AGRICULTURAL USE, URBAN - The use of a lot or portion of a lot within the Urban Service Area that is less than five (5) acres for a community garden as regulated further in the Code of Ordinances.

AGRIBUSINESS - An agricultural business entity comprised of a person, partnership, limited partnership, corporation, limited liability company, or any other entity engaged in a business that processes raw agricultural products, including timber, or provides value-added functions with regard to raw agricultural products.

AGRITOURISM - Activities conducted on an active farm; or at an agricultural, horticultural or agribusiness operation that are offered to the public for the purpose of enjoyment, education or active involvement in the activities of the active farm or facility. These activities shall be integrated into, directly associated with, and incidental and subordinate to the principal agricultural production on the property.

AMUSEMENT PARK - An outdoor facility, which may include structures and buildings, for entertainment, including motorized rides, water slides, miniature golf, batting cages, performance stages or theaters, and booths or kiosks for the conduct of games or sale of items. Such uses may also include entertainment associated with a carnival.

ANIMAL GROOMING FACILITY - An establishment where domestic animals are bathed, clipped or combed for the purpose of enhancing their appearance or health, and for which a fee is charged; but not including overnight boarding of animals.

ASSISTED LIVING FACILITY - A residential facility, other than a nursing home, with multiple and separate living facilities, generally for persons who are fifty-five (55) years of age or over. Meal

preparation, laundry services, room cleaning, transportation, and/or recreation may also be provided, as well as some medical services, exclusively for the residents of the facility.

ATHLETIC CLUB FACILITY - An establishment that provides for indoor commercial or non-commercial services and facilities that purport to improve the user's physical condition or appearance through participation in sports activities, fitness training, exercise, or body building. The establishment may offer access to the following: gymnasiums, swimming pools, tracks, ball courts, weight lifting equipment, exercise equipment or facilities, saunas, steam baths or whirlpools.

AUTOMOBILE AND TRUCK REPAIR, MAJOR - Rebuilding or reconditioning of engines or transmissions, vehicles or trailers; repair and collision service, such as body, frame, or fender straightening; painting and clear coating; upholstery; auto glass work; and the like.

AUTOMOBILE AND TRUCK REPAIR, MINOR - Minor repairs and routine maintenance, including oil and filter change; lubrication; engine tune-up; troubleshooting and replacement of lights; brakes and other prepackaged components; and tire rotation or replacement, but not including any operation specified under "Automobile and Truck Repair, Major."

AUTOMOBILE AND VEHICLE REFUELING STATION - A building, structure or lot used for dispensing of compressed natural gas or any liquefied petroleum gas from a storage vessel by means of a compressor or pressure booster into motor fuel cylinders in automobiles and motor vehicles. This use does not include a bulk distribution plant, but may be part of an automobile service station.

AUTOMOBILE SERVICE STATION - A building or structure used for minor automobile and truck repair; the retail sale and dispensing of fuel, lubricants, tires, batteries, accessories, and supplies, including installation and minor services customarily incidental thereto; facilities for washing and for chassis and gear lubrication are permitted if enclosed in a building.

BANQUET FACILITY - A building made available to the public for holding meetings and social events. This use may include the sale of alcoholic beverages; indoor live entertainment; and may also include, as an accessory use, events conducted outside the main building in tents or other temporary facilities, subject to the issuance of a permit by the Division of Building Inspection.

BED AND BREAKFAST FACILITY - A use which provides short-term transient lodging, including serving only breakfast to overnight lodgers, for which rent is paid and subject to the following conditions:

- (1) The use shall be clearly incidental and secondary to the use for dwelling purposes;
- (2) The use shall be carried on only by owners with at least a fifty-one percent (51%) ownership interest, and who reside on the premises;
- (3) The use shall not require external alteration of the dwelling except as may be required to meet fire and building codes;
- (4) Each room to be rented shall be designed and intended to accommodate no more than two persons;
- (5) Each room shall be rented for no longer than seven (7) consecutive days. Any facility which rents rooms for more than seven days shall be regulated as a boarding house;
- (6) The use shall not adversely affect the uses permitted in the notification area and in the immediate neighborhood by excessive traffic generation, noise and the like;
- (7) The owner-operator shall maintain a guest log and other records, which shall be subject to annual review and inspection;
- (8) The use shall not be conducted within any accessory building in a residential zone;
- (9) The conditional use permit shall become null and void upon the sale or transfer of the property;
- (10) All off-street parking areas shall be completely screened with landscaping;
- (11) The use shall be in compliance with all applicable state and local laws, including Health Department rules and regulations.

BOARDING OR LODGING HOUSE - A residential building, or part thereof, for five (5) or more adults living together, not as a family or housekeeping unit. In identifying this use, one or more of the following factors shall be considered:

- (a) meals and/or food costs are typically not shared;
- (b) rent is established by leases to individuals, or rents are based on charges assessed to each individual;
- (c) individual mailboxes are provided;
- (d) multiple utility meters or connections are present.

BOTANICAL GARDEN - A garden dedicated to the collection, cultivation and display of a wide range of plants.

BREW-PUB - A restaurant with an area devoted to the accessory sale of wine or alcoholic beverages, which also houses an accessory micro-brewery without permanently installed bottling equipment, all within the same completely enclosed building.

BUILDING - Any structure for the shelter or enclosure of persons, animals or property.

BUS AGENCY - A facility providing inter-city transportation to passengers and other bus customers, limited to loading and unloading of passengers and/or freight, and the sale of tickets and/or shipping space; but not to include activities exclusive to a passenger transportation terminal.

BUSINESS COLLEGE, TECHNICAL OR TRADE SCHOOL, OR INSTITUTION - An educational institution primarily owned and operated by an individual, partnership, or corporation offering training in business, trade, technical or related areas through residence, extension, or correspondence, for which tuition is charged. Such training shall not include any courses or instruction in which the field or occupation would not be a permitted use within the zoning category in which the institution is located.

CABLE TELEVISION SYSTEM - Any system which receives and amplifies signals broadcast by one or more television and/or radio station and which transmits programming or other electronic or optical signals originated by the system itself or by another party by wire or cable to persons who subscribe to such service.

CAMPGROUNDS - An outdoor facility for short-term overnight recreational use.

CAMPGROUNDS, PRIMITIVE - A lot or parcel of land without amenities, such as water or electricity, to individual camp sites upon which tents are placed. Shared bathroom facilities and parking areas are permitted.

CAMPGROUNDS, RECREATIONAL VEHICLE OR TRAILER - A lot or parcel of land upon which two or more recreational vehicle sites are located for occupancy by recreational vehicles, trailers or tents. Water and electricity to individual camp sites is typical.

CARNIVAL - A temporary outdoor amusement use in a business or industrial zone lasting no longer than ten days per calendar year that includes mechanical rides, with or without inflatables. Such uses may also include games, live music, games of chance, live entertainment (other than typically associated with a "circus," defined herein), booths, food service, merchandise sales, pony rides and/or a petting zoo intended for children. A carnival does not include a circus, activities conducted at the state-designated County Fair or events at a fairgrounds designated for that activity. Carnivals may not be conducted on any property during the state-designated County Fair, or during the two weeks immediately prior to the County Fair.

CELLULAR TELEPHONE TRANSMITTING FACILITY, TEMPORARY - Any system of wires, poles, rods, reflecting disks, or similar devices used for the transmission or reception of electromagnetic waves, not meeting the definition of a "structure" as defined by this Zoning Ordinance.

CHILD CARE CENTER - Any facility which provides full or part-time care, other than family child care, day or night, to children who are not the children, grandchildren, nieces, nephews, or children in legal custody of the operator, as regulated by the Commonwealth of Kentucky.

CHILD CARE, FAMILY - An incidental and subordinate use within a dwelling and not an accessory structure, where full or part-time care is provided by a resident of the dwelling, for a fee, to children, as regulated by the Commonwealth of Kentucky.

CHILDREN'S RIDES - A temporary outdoor amusement device, not involving a permanent structure, primarily designed for persons less than five (5) feet in height or less than thirteen (13) years of age, including mechanical rides and/or inflatables. Such uses may also include pony rides and/or petting zoos.

CIRCUS - A temporary use or special event lasting no longer than ten days per calendar year that is intended or likely to attract substantial crowds to view entertainment and animal performances or displays (other than a petting zoo intended for children and/or outdoor pony rides), and which is not usually associated with the principal use of the property where the special event is to be located. Such uses may or may not also include rides, games, booths, food service and merchandise sales. No accessory structure associated with a circus can be constructed or erected on a lot without a principal structure thereon.

CLINIC, MEDICAL - A building, or part thereof, designed and used for the diagnosis and treatment of human patients that does not include overnight care facilities.

CLUB, PRIVATE - Buildings and facilities, the purpose of which is to render a social, educational, or recreational service to members and their guests; and not primarily to render a service customarily carried on as a business or to render a profit. Private club shall include country club.

COCKTAIL LOUNGE - A commercial establishment dispensing and serving alcoholic beverages for consumption on the premises and in which live entertainment, exclusive of dancing, is permitted.

COMMERCIAL COMPOSTING - The aerobic or anaerobic decomposition of solid, organic materials to produce a stabilized, humus-like material that can be recycled to the land as a soil conditioner and low grade fertilizer, and primarily for use or distribution off the production site.

COMMERCIAL GREENHOUSE - An establishment primarily engaged in propagating and growing plants in containers, in soil or in other growing medium for the purpose of being sold and transplanted. This definition shall include sale of the following items: plants grown on the premises or tended in a controlled environment of the greenhouse or plant nursery; sale of fungicides, insecticides, chemicals, peat moss, humus, mulches, and fertilizer, all to be used in the soil or upon the live plant to preserve the life and health of the plants sold; landscape counseling, site planning and contracting services when not the primary activity and when using plants grown or tended on the premises of the greenhouse or plant nursery.

Note: This definition applies only to land use as provided for in the Zoning Ordinance and Subdivision Regulations and is not intended to affect the status of any business with regard to any federal or state tax laws or similar statutes.

COMMISSARY - Premises used for preparation of food for restaurant use.

COMMISSION - Lexington-Fayette Urban County Planning Commission.

COMMUNITY CENTER - Buildings and facilities for a social, educational, or recreational purpose, operated by a non-profit organization, which are generally open to the public and which do not render a service customarily carried on as a business.

COMMUNITY RESIDENCE - A building or group of buildings for up to eight (8) children or adults, not receiving counseling or recovering from drug or alcohol abuse or a psychiatric disorder and not assigned to the home as a condition of parole or probation, who by virtue of their physical or mental needs must reside temporarily in a supervised home. More than eight such residents shall be permitted only as a rehabilitation home.

COMPREHENSIVE PLAN - The adopted plan for Lexington-Fayette County, which serves as a guide for public and private actions and decisions to assure the development of public and private property in the most appropriate relationships. Such plan shall include all elements, whether expressed in words, graphics, or other forms.

CORN MAZE - A recreational facility that creates a labyrinth utilizing an agricultural product intended to be harvested, such as corn, to create a system of paths. This definition shall apply to "hay mazes" as well.

COUNTRY INN - A private facility located in a rural setting that has six (6) or more guest rooms or suites for transient occupancy, in which breakfast and other meals may be served to the guests, and whose innkeeper resides on the premises or property adjacent to the premises during periods of occupancy. This definition does not include boarding or lodging houses, bed and breakfast facilities, motels, hotels, or extended-stay hotels.

COURTYARD - An open area, partially or completely surrounded by buildings, used as outdoor common area, generally paved and/or landscaped, and primarily for private use. This may also be used to meet the open space requirement of the Zoning Ordinance as herein defined.

CULTURAL TOURISM - Activities associated with geographical places, artifacts, architecture and/or past events that represent the stories and people of the past offered to the public for the purpose of education and enjoyment. These activities should not diminish the place, element or feature for future generations.

DAY SHELTER - Facilities which provide on a free or not-for-profit basis access to indoor shelter, generally during the hours encompassing dawn to dusk, and which may also provide in conjunction therewith personal support services, primarily to, or intended for, persons who otherwise may not have access to indoor shelter if only available on a cost or for profit basis. This definition shall not include temporary emergency heating or cooling shelters which operate only during extreme weather periods.

DEVELOPMENT IMPROVEMENTS - Physical changes made to raw land, and structures placed on or under the land surface, in order to make the land more useable for human activities. Typical development improvements referenced in these regulations are grading, street pavement, curbs, gutters, drainage ditches, storm and sanitary sewer facilities, utility lines of all types, street name signs, property number signs, trees, etc. As used herein, development improvements may also be referred to as development or improvements.

DIAMOND MESH WIRE - A fencing material typically used in rural areas which, by its strength and construction, is effective in prevention of climbing and in control of animal movement. The term shall also be construed to include fencing commonly referred to as "V" mesh fencing. The term does not include chain link fencing.

DIVISION OF ENGINEERING MANUALS - The Division of Engineering Manuals (also known as the Engineering Manuals, or the Manuals) is a set of seven documents to provide standards for the design, review, construction, and inspection of infrastructure. The Engineering Technical Manuals are Construction Inspection (also known as the Inspection Manual), Geotechnical, Roadway, Sanitary Sewer and Pumping Station, Stormwater, and Structures. In addition to the six Technical Manuals, a Procedures Manual for Infrastructure Development (also known as the Procedures Manual) establishes the responsibilities and procedures to be used by the Lexington-Fayette Urban County Government, the land developer and the project engineer. These Manuals

are hereby adopted by the Urban County Government and incorporated into this Zoning Ordinance by reference. From time to time, the Urban County Government may revise, modify, or amend the Manuals in conformance with the procedure established in the Procedures Manual. When any of the Engineering Manuals are cited by this Zoning Ordinance, the current edition, latest revision, shall be referenced.

DORMITORY - A building containing sleeping rooms operated by a school for academic instruction, or by a business college, technical or trade school, for which admission to residency is limited exclusively to students of such an institution, school or college. Where kitchen facilities or provisions for such are provided, such rooms shall be deemed dwelling units.

DRIVEWAY, FOR SINGLE FAMILY AND TWO-FAMILY DWELLINGS - A private paved vehicular access, a maximum of twenty-four (24) feet in width, or ten (10) feet in width when inside the Infill and Redevelopment Area, extending on the shortest reasonable path through the front yard or side street side yard to the required off-street parking area. All other areas paved for vehicular use within any front or side street side yard shall be considered additional parking and shall be subject to the area limitations and landscaping requirements of this Zoning Ordinance.

DWELLING - A building, or portion thereof, occupied exclusively for residential purposes, not including a mobile home or trailer.

DWELLING, MULTIPLE FAMILY - A building, or portion thereof, occupied exclusively for residential purposes by more than two (2) families or more than two (2) housekeeping units.

DWELLING, SINGLE FAMILY - A building occupied exclusively for residential purposes by one family or one housekeeping unit. Townhouses are included in this definition.

This definition also includes a building occupied by five (5) or more unrelated individuals at any time within five years prior to January 1, 2010, subject to the following:

- (a) the occupancy is restricted to six (6) or less unrelated individuals;
- (b) the use of the building as a rental dwelling has not been abandoned;
- (c) the building shall not be enlarged or expanded beyond the existing square footage as of January 1, 2010:
 - 1. by more than 25% unless the building has been expanded by 25% or more under a building permit issued on or after January 1, 2005, in which case, then by no more than 5%; or
 - 2. unless approved by the Board of Adjustment as a conditional use after January 1, 2010.

DWELLING, TWO-FAMILY - A building occupied exclusively for residential purposes by two families or two housekeeping units, commonly known as a duplex. Townhouses are not included in this definition.

This definition also includes a building occupied by five (5) or more unrelated individuals in a unit at any time within five years prior to January 1, 2010, subject to the following:

- (a) the occupancy of each unit is restricted to six (6) or less unrelated individuals;
- (b) the use of the building as rental dwellings has not been abandoned;
- (c) the building shall not be enlarged or expanded beyond the existing square footage as of January 1, 2010:
 - 1. by more than 25% unless the building has been expanded by 25% or more under a building permit issued on or after January 1, 2005, in which case, then by no more than 5%; or
 - 2. unless approved by the Board of Adjustment as a conditional use after January 1, 2010.
- (d) the limitation on enlargement of the building set forth in (c) above shall not apply in the case of the addition of a second unit in a Two-Family (R-2) zone, provided that both units thereafter conform to the limitation of four unrelated persons per dwelling unit.

DWELLING UNIT - One room or rooms connected together, constituting a separate, independent housekeeping establishment for occupancy by a family as owner, by rental or lease on a weekly, monthly or longer basis; physically separated from any other rooms or dwelling units which may be in the same building, and containing independent kitchen and sleeping facilities.

ECOTOURISM – Activities conducted in natural, greenspace, or environmentally sensitive areas that are offered to the public for the purpose of enjoyment, education, and active involvement in the activities of the site. These activities shall safeguard the integrity of a natural feature, habitat or ecosystem.

ELDERLY HOUSING - Multiple family structures containing at least twenty-four (24) units and solely devoted to housing families consisting of two (2) or more persons, of which the head (or his spouse) is sixty-two (62) years of age or over, or is handicapped; and single persons who are sixty-two (62) years of age or over, or are handicapped.

ENGINEER, PROJECT - A person currently licensed to practice engineering in the State of Kentucky and in good standing with the Kentucky Board of Registration for Professional Engineers and Land Surveyors; or a firm in good standing as an Engineering company in Kentucky, if the work is to be accomplished other than as a sole practitioner. Work performed under the supervision or at the direction of the project engineer, including, but not limited to: preparation of plans, inspections, reports, testing, and directives or orders regarding work pursuant to these

Subdivision Regulations, shall be considered to be the work of the project engineer. Whenever qualifications are questioned, the Commission will consult with the Bluegrass Chapter of the Kentucky Society of Professional Engineers or the Consulting Engineers Council of Kentucky.

ENGINEER, URBAN COUNTY - The Director of the Lexington-Fayette Urban County Government Division of Engineering.

ENTERTAINMENT, LIVE - Any performance at a restaurant, cocktail lounge, or night club by any person; including, but not limited to, a patron of such establishment if such performance is part of a regularly occurring event. Live entertainment includes, but is not limited to: singing, dancing, musical performance, comedy acts, magic acts, variety acts, or performance contests engaged in by patrons.

ENTRANCE, PRIMARY - Entrance used as the main pedestrian access point of a structure and along the front lot line.

EQUINE HOSPITAL - A veterinary hospital used primarily for the treatment and care of horses, which may include office facilities and the storage of medicinal supplies when accessory to the primary use.

ESTABLISHED GRADE - The finished elevation, at any point, of the ground level at the base of a fence, wall or projection.

EXTENDED-STAY HOTEL - Multiple family dwelling(s) with rental or lease of less than one week, provided such rentals or leases of less than one week shall comprise less than 50% of the total dwelling units within the structure(s).

FAMILY OR HOUSEKEEPING UNIT - A person living alone, or any of the following groups living together and sharing common living and kitchen facilities:

- (a) Any number of persons related by blood, marriage, adoption, guardianship, or other duly authorized custodial relationship;
- (b) Four (4) or fewer unrelated persons;
- (c) Two (2) unrelated persons and any children related to either of them or under their care through a duly authorized custodial relationship;
- (d) Not more than eight (8) persons who are:
 1. Residents of a "home-like" residence, as defined in KRS 216B.450;
 2. "Handicapped" as defined in the Fair Housing Act, 42 U.S.C., Section 3602(h). This definition does not include those currently illegally using or addicted to a "controlled substance" as defined in the Controlled Substances Act, 21 U.S.C., Section 802(6).
- (e) Not more than six (6) unrelated individuals when in compliance with the provisions of the definitions of "dwelling, single family" or "dwelling, two-family," as contained in this Article.
- (f) A functional family as defined and regulated

FAMILY, FUNCTIONAL - A group of five (5) or more persons, not otherwise meeting the definition of "family," who desire to live as a stable and permanent single housekeeping unit and who have received a conditional use permit from the Board of Adjustment. "Functional family" does not include:

- (a) residents of a boarding or lodging house;
- (b) fraternity, sorority or dormitory;
- (c) any lodge, combine, federation, coterie or like organization;
- (d) any group of individuals whose association is temporary or seasonal in nature;
- (e) any group of individuals who are in a group living arrangement as a result of criminal offenses.

FARM GIFT SHOP – An accessory retail facility limited to a maximum of five hundred (500) square feet in size that offers for sale farm products grown or raised on the premises, and/or memorabilia representative of the farm products grown or raised on the premises, such as hats, shirts, and souvenirs.

FARM MARKET, COMMERCIAL – An occasional or periodic market held in an open area or in a structure where groups of individual sellers offer for sale to the public primarily agricultural products such as fresh produce, seasonal fruits, fresh plants or flowers, value-added products, arts and crafts items, and food and beverages (but not to include second-hand goods) dispensed from booths located on-site. Farm markets shall not include the sale of livestock.

FARM PRODUCERS - Any person, persons or legal entities who are actually engaged in the business of producing/growing farm raised products they sell at the market.

FARM TOUR – An accessory use to a working or active farm or other agricultural use that permits visitors a way to see and experience on-going agricultural operations and facilities, but shall not include overnight accommodations.

FESTIVAL – A temporary public or commercial gathering lasting no longer than ten days per calendar year where entertainment, food, crafts, and the like are offered for viewing or for sale.

FISHING OR HUNTING CLUB – Areas reserved for public or private hunting of wildlife, fishing, and accessory structures in support of those activities, but shall not include overnight accommodations, or rifle or other firearm ranges.

FISHING LAKE – A body of water that is located on private property where a fee is paid in order to fish.

FLOOR AREA - The sum of the gross areas of the several floors of a building or buildings measured from the exterior faces of exterior walls or from the centerlines of walls separating two buildings. In particular, floor area includes:

- (a) basement space at least seven and one-half (7½) feet in height;
- (b) elevator shafts or stairwells at each floor;
- (c) penthouses;
- (d) attic space (whether or not a floor has been laid) providing structural headroom of seven and one-half (7½) feet or more; interior balconies, mezzanines, hallways, lobbies;
- (e) floor space in accessory buildings not used for off-street parking;
- (f) laundry rooms, game rooms, or other spaces designed for the common use of the occupants;
- (g) any other floor space not specifically excluded.

However, the floor area of a building shall not include:

- (a) non-habitable basement space which is less than seven and one-half (7½) feet in height;
- (b) elevator or stair bulkheads;
- (c) accessory water tanks, or cooling towers;
- (d) outside steps that are uncovered;
- (e) attic space (whether or not a floor has been laid) providing structural headroom of less than seven and one-half (7½) feet;
- (f) mechanical equipment space;
- (g) interior space used exclusively as parking space for motor vehicles.

FLOOR AREA, PARKING - The floor area of a structure as defined herein, exclusive of any covered pedestrian area in a mall, less storage and warehouse areas, laundry rooms, game rooms, or other spaces designed for the common use of the occupants, and used principally for non-public purposes of said structure. Any basement or cellar space used for retailing shall be included in the parking floor area for the purpose of calculating requirements for accessory off-street parking spaces and accessory off-street loading berths.

FLOOR AREA RATIO - Floor area of buildings on a lot divided by pre-development net ground area of the lot on which it is located.

FRATERNITY OR SORORITY HOUSE - A building used as a living and/or gathering quarters for students of a college, university or seminary (not living in a “dormitory” as defined herein) who are members of a fraternity or sorority that has been or is seeking to be officially recognized by the college, university or seminary; or their guests. In identifying such use, the following factors shall be among those considered, regardless of number of occupants:

- (a) signage or other indications that the building is used by a fraternity or sorority;
- (b) fraternity- or sorority-sponsored social activities, such as meetings; parties; dances or other gatherings; and
- (c) events to which fraternity or sorority alumni or prospective members are invited.

A “Family or Housekeeping Unit” or “Boarding or Lodging House” as defined herein are excluded, unless the use demonstrates specific characteristics of use as set forth above.

GARAGE, COMMUNITY - A structure or structures only for the storage of passenger vehicles or trailers of residents of the neighborhood.

GARAGE, PRIVATE - A space or structure, including a carport, on the same lot with or in the building to which it is accessory, primarily for storage of passenger vehicles of the residents of the premises, with no facilities of a commercial or public nature.

GARDEN CENTER - Establishments used primarily for the sale of live plants, including greenhouses and plant nurseries. When accessory to the sale of plants, the sale of the following items shall be allowed: cut plants, cut trees and wreaths, bulbs and seeds which may have been transported to the premises for the purpose of resale; ground covers; fungicides, insecticides, chemicals, peat moss, humus, mulches and fertilizers; lawn statuary, furniture, bird baths, bird feeders, birdhouses and pottery; pots and containers for plants; artificial flowers; home lawn and garden equipment, including manual and automatic grass cutting devices, grass seeding devices, mulchers, thatchers, tillers, but not including farm tractors and machinery; garden landscape devices, including railroad ties, stepping stones, fencing, edging, trellises, plastic and burlap; hand tools such as sprayers, shovels, dusters, rakes, hoes, and watering devices; firewood; landscape planning and contracting services incidental to the garden center to include contractual services for lawn and garden sprigging, maintenance, fertilizing, spraying and mowing.

GARDEN, MARKET - An area of land less than five (5) contiguous acres in size for the cultivation of food and/or non-food crops by an individual or a group of individuals to be sold on site. Such a garden may be located on the ground, in raised beds, or on rooftops; and may utilize greenhouses, hoop houses, high tunnels, vertical gardens, hydroponic systems or aquaponics systems alone or in combination with other techniques for growing food or non-food crops.

GREENWAY - An area defined as a "greenway" in the Comprehensive Plan or other adopted plan.

HAZARDOUS MATERIALS - Any chemical, biological or radiological compound, gas, oil, gasoline, lubricant or other petroleum products, substances, solution or mixture which, because of its quality; quantity; concentration; physical or infectious characteristics; or any combination thereof, when released into the environment, presents or may present harmful or potentially harmful effects to human health or welfare or the environment.

HEIGHT OF BUILDING - The vertical distance from the established grade in front of the lot or from the average natural grade at the base of the front building wall, if higher, to the average height of the top of the cornice of flat roofs, or roof line or to the deck line of a mansard roof, or to the middle height of the highest gable or dormer in a pitched or hipped roof; or if there are no gables or dormers, to the middle height of such pitched or hipped roof. See Article 15 for general height regulations.

HEIGHT-TO-YARD RATIO - Height of building as related to minimum rear and each side yard permitted; i.e., for 2:1 ratio, a 40-foot building must have a minimum rear and each side yard of twenty (20) feet.

HELIPORT - A facility used exclusively for helicopter operations, including landing; takeoff; loading; discharging; fueling; maintenance; and/or transient storage of helicopters.

HELISTOP - A facility used exclusively for helicopter landing, take-off, loading, discharging, and/or transient storage of helicopters; but not including facilities for maintenance, fueling or long-term storage of helicopters.

HISTORIC DISTRICT, LOCAL - A designation that carries with it a design review process, within the purview of the Board of Architectural Review, that is based on specific design guidelines for exterior work and changes to the property. Properties that are within a Local Historic District carry an H-1 overlay zone in addition to the underlying zoning category.

HISTORIC DISTRICT, NATIONAL REGISTER - A federal designation, awarded by the Department of the Interior, which provides recognition of a property's archaeological, architectural or historical significance.

HISTORIC HOUSE MUSEUM - A building currently or formerly used as a residence, having public significance by reason of its architecture or former use or occupancy; designed for preserving and exhibiting artistic, historical, scientific, natural or man-made objects of interest. This use may also include, as an accessory use, the sale of objects collected and memorabilia; the sale of crafts and artwork; and the holding of meetings and social events.

HOME-BASED BUSINESS - A gainful occupation or profession carried on in a residence that involves: (a) customers or clients coming to the residence; and/or (b) the use of materials or equipment that are potentially disturbing to surrounding properties due to noise, odors, flammability or some other risk factor. Examples include, but are not limited to, individual music instruction; athletic training; counseling services; upholstery work; and firearm repair.

Home-based businesses shall not include barber shops; beauty parlors; offices for escort services; massage parlors, automobile and small engine repair; medical or dental offices; palm reading or fortune telling; home cooking and catering; and uses, other than upholstery, which are first permitted in the B-4, I-1 or I-2 zone.

HOME OCCUPATION - A gainful occupation or profession carried on in a residence that does not involve customer or client visits to the residence; does not involve the handling of firearms; and materials or equipment used in the conduct of the home occupation is limited to items that have minimal potential for disturbing surrounding properties due to noise or potentially harmful chemicals. Examples include, but are not limited to, sewing, handicrafts and computer graphics and/or design.

HOME OFFICE - An office for record keeping and administration of work.

HOSPICE - A facility that provides support and care for persons in the last stage of an incurable disease or condition, and to their families. Overnight, in-patient and out-patient facilities may be included, as well as offices, storage and an associated pharmacy. Medical care, palliative care, counseling and education may be provided.

HOSPITALITY HOUSE - A multi-family residence or boarding facility operated strictly on a non-profit basis, by a non-profit organization and utilized solely for the provision of temporary lodging for the immediate family and/or legal guardians of an individual undergoing treatment within a local hospital.

HOTEL - A building or group of buildings containing individual sleeping or living units, designed for the temporary occupancy of transient guests; and including hotels, tourist courts, motor lodges, motor hotels or auto courts, but not including boarding or lodging houses.

INFILL AND REDEVELOPMENT AREAS - Areas located within the Urban Service Area of Lexington-Fayette County, generally characterized by lots that were established prior to 1934. Excluded from these areas are lots that are located in an identified National Register Historic District where average residential lot sizes are greater than 9,500 square feet, and as more particularly described in the adopted Comprehensive Plan map of the Infill and Redevelopment areas.

INFRASTRUCTURE DEVELOPMENT AGREEMENT - An agreement for a project in which infrastructure improvements are proposed to be constructed among the LFUCG, the developer, and the project engineer, which specifies the obligations and requirements of the parties. The Infrastructure Development Agreement shall be in a form and contain the requirements set forth in the Procedures Manual.

JUNK YARD - An outdoor area where waste or discarded or salvaged materials or inoperable vehicles are bought, sold, exchanged, stored, baled, cleaned, packed, disassembled, or handled, including auto wrecking yards, used lumber yards and places or yards for use of salvaged house wrecking and structural steel materials and equipment; but excluding such uses when conducted entirely within a completely enclosed building. A junk yard does not include recycling drop-off centers, pawn shops, establishments for the sale, purchase or storage of used cars in operable condition, salvaged machinery, used furniture and household equipment; the processing of used, discarded or salvaged materials as part of manufacturing operations; and vehicle storage yards.

KENNEL - Commercial business for the sale or temporary boarding of more than three (3) dogs, but not including the ownership and occasional sale of dogs at, in, or adjoining a private residence.

KITCHEN FACILITIES - Equipment arranged in a room or some other space in a structure which facilitates the preparation of food, including, but not limited to, a combination of two or more of the following -- a range, microwave oven, dishwasher, kitchen sink, or refrigerator.

LIGHTING CUTOFF - Any shielding that conceals the source of lighting visible from the property lines of a site.

LOT - A parcel of land of at least sufficient size to meet the minimum zone requirements for use, coverage and area, and to provide such yards and open spaces as required under this Zoning Ordinance.

LOT AREA - The amount of surface land contained within the property lines of a lot, including land within easements on the lot, but excluding any land within street right-of-way.

LOT, CORNER - A lot abutting upon two (2) or more streets at their intersection or upon two (2) parts of the same street; and where, in either case, the interior angle formed by intersection of the street lines does not exceed one hundred thirty-five (135) degrees.

LOT COVERAGE - The computed ground area occupied by all buildings within a lot.

LOT DEPTH - The mean horizontal distance between the front and rear lot lines.

LOT FRONTAGE - The distance between the side lot lines measured along the front building line of the lot, as determined by the prescribed front yard requirement of the zone in which the lot is located, or as designated by the final record plat, whichever is greater.

LOT LINES - The property lines bounding the lot.

LOT LINE, FRONT - In the case of a lot abutting upon only one street or alley, the line separating such lot from such street. In the case of any other lot, the owner shall, for the purpose of this Zoning Ordinance, have the privilege of electing any street lot line as the front lot line, provided that such choice, in the opinion of the Division of Planning or the Division of Building Inspection, as appropriate, will not be injurious to the existing, or to the desirable future development of adjacent properties.

LOT LINE, REAR - Ordinarily, that lot line which is opposite and most distant from the front lot line. In the case of an irregular, triangular or gore-shaped lot, a line ten (10) feet in length entirely within the lot, parallel to and most distant from the front lot line shall, for the purpose of this Ordinance, be considered the rear lot line. In other cases not covered herein, the Division of Planning or the Division of Building Inspection, as appropriate, shall designate the rear lot line.

LOT LINE, SIDE - Any lot line other than a front or rear lot line.

LOT LINE, STREET OR ALLEY - A lot line separating the lot from a street or alley.

LOT WIDTH - The mean horizontal distance across the lot, measured at right angles to the depth.

MAIL ORDER BUSINESS - A business engaged in the sale of manufactured products, goods, merchandise and finished products primarily through means of mail or telephone orders, including the administrative offices of such business.

MAIL SERVICE FACILITY - A commercial establishment that conducts the retail sale of stationery products, provides packaging and mail services to retail customers, and provides mailboxes for lease.

MASSAGE PARLOR - An establishment where, for any form of consideration, massage, alcohol rub, fomentation, electric or magnetic treatment, or similar treatment or manipulation of the human body is administered, unless such treatment is administered by a medical practitioner; chiropractor; acupuncturist; physical therapist or similar professional person licensed by the Commonwealth of Kentucky or another state. This definition does not include an athletic club facility, health club, school, gymnasium, reducing salon or similar establishment where massage or similar manipulation of the human body is offered as an incidental or accessory service.

MICRO-BREWERY - A facility within a completely enclosed building which is intended for the production of up to 25,000 barrels per year of malt beverages, under the terms and conditions specified by KRS 243.157, KRS 243.150, and other applicable laws.

MINING - Underground excavation made into the earth from which to extract materials produced for sale, exchange or commercial use.

MIXED-INCOME HOUSING UNIT - A dwelling unit provided for sale to an owner-occupant household with an income that does not exceed 100% of median income (adjusted for family size), or for rent to a household with an income that does not exceed 80% of the median income (adjusted for family size) for Lexington-Fayette County. A unit shall be deemed a mixed-income housing unit for an owner-occupant if the total amount of principal, interest, taxes and insurance does not exceed 36% of the household's income; and a unit shall be deemed affordable to a rental household if the total rent, including any tenant-paid utilities, does not exceed 30% of the household's income. In the alternative, a fixed price may be set for a mixed-income housing unit for sale to an owner-occupant if the total principal and interest (for a 30-year mortgage) does not exceed 30% of the total household income for a family of four at 80% of the median income for Lexington-Fayette County; also, if the unit is for rent, then the maximum monthly rent may not exceed 1% of a household income that is at 80% of the median income for Lexington-Fayette County.

MOBILE HOME - Any factory-built structure, with or without a permanent foundation, as defined in KRS 227.550, which is designed and constructed on a permanent chassis to permit occupancy for dwelling or sleeping purposes, either permanent or temporary, when connected to the required utilities; and includes the plumbing, heating, air-conditioning and electrical systems contained therein. These are also known as "manufactured homes," which are regulated by the federal government and the State Fire Marshall, and are required to carry only a "HUD" seal applied by the manufacturer.

MOTEL - A building or group of buildings, containing individual sleeping or living units, designed for the temporary occupancy of transient guests and including hotels; tourist courts; motor lodges; motor hotels or auto courts; but not including boarding or lodging houses.

NATURE PRESERVE - An area intended to remain in a predominantly natural or undeveloped state to provide resource protection, which may include possible opportunities for passive recreation and environmental education for present and future generations.

NEIGHBORHOOD DESIGN OVERLAY ZONE - An overlay zone, applied in addition to the underlying zoning category, whereby key characteristics of a particular neighborhood or area are preserved for either new building (infill) construction or replacement of existing structures.

NIGHTCLUB - A commercial establishment for dancing and live entertainment, which may or may not include dispensing and serving alcoholic beverages for consumption on the premises.

NURSING HOME - A facility for which four (4) or more persons may be admitted for periods exceeding twenty-four (24) hours to receive treatment and/or medication for bodily illness, including convalescence from illness.

OPEN SPACE, USEABLE - Outdoor area of a lot or tract which is designated and used for outdoor living, recreation, pedestrian access or planting. Such areas may be ground or roof space seventy-five percent (75%) open to the sky, balconies a minimum of five (5) feet wide, an enclosed deck, porch, or ground floor portions of a building constructed on columns. Off-street parking and loading areas, driveways, vehicular use area perimeter landscaping and interior landscaping, unenclosed fire escapes, or required front and side street side yard areas do not qualify as useable open space; provided, however, that those portions of the required side street side yard may qualify as useable open space, as long as such open space is separated from the street right-of-way by a fence or solid screen planting.

PARKING LOT, AREA, OR STRUCTURE - An area not within a building for temporary (less than 24-hour) off-street parking, loading or unloading of vehicles, whether required or permitted by this Zoning Ordinance; including driveways, access ways, aisles, and maneuvering areas; but not including a loading dock or any public or private street right-of-way.

PASSENGER TRANSPORTATION TERMINAL - A facility used by one or more bus companies in providing inter-city transportation of passengers and goods; including, but not limited to, vehicle storage and maintenance, continuous use by multiple buses, and services for bus transients, such as food, restrooms, and waiting areas, as well as activities permitted as a bus agency.

PAVED AREA - An area of concrete, asphalt, brick, permeable pavers or other suitable hard surface materials; excluding loose aggregate or other types of gravel.

PAWNSHOP - Any establishment which loans money on deposit of personal property, or which deals in the purchase of personal property on condition of selling the property back again at a stipulated price; or which makes a public display at its place of business of the sign generally used by pawnbrokers to denote their business; or which publicly exhibits a sign advertising money to loan on personal property for deposit.

PERMEABLE PAVING MATERIALS - Paving materials that permit the movement of water under ordinary hydrostatic pressure. This does not include gravel or loose aggregate.

PERSONAL CARE FACILITY - A long-term facility with resident beds, devoted primarily to the care of aged or invalid persons who do not require the level of intensive care normally provided in a hospital or nursing home; but who do require care in excess of room, board and laundry.

PERSONAL SERVICE OR PERSONAL SERVICE ESTABLISHMENT - Commercial business providing services to individuals, such as beauty and barber shops, shoe repair, dressmaking and tailoring.

PETTING ZOO - A collection of farm animals or domesticated animals for children to pet and feed.

PLANT NURSERY - An establishment engaged in the outdoor cultivation of only trees and shrubs for transplanting. A greenhouse may be an accessory structure when used to propagate and prepare the trees or plants for planting on the premises.

PLAZA - A public square or extra wide sidewalk (e.g., on a street corner) that allows for special events, outdoor seating, sidewalk sales, and similar pedestrian activities (similar to a courtyard; however, primarily for public, as opposed to private, use).

POOL OR BILLIARD HALL - Any establishment which has, as part of its operation, three (3) or more pool or billiard tables on the premises.

PRIMARY ENTRANCE - The place of ingress and egress for a structure used most frequently by the public.

PRINCIPAL STRUCTURE - A building in which is conducted a principal or conditional use. In any residential zone, any structure containing a dwelling unit shall be deemed a principal structure on the lot on which the same is located. Where a non-conforming use is the primary use on the property, the building in which it is located shall be deemed a principal structure.

PRIVATE WALKWAY - A paved area used for pedestrian activity outside of the public right-of-way.

QUARRYING - Surface excavation for the extraction of any non-metallic mineral, excluding coal, which is produced for sale, exchange, or commercial use.

RECREATION, ACTIVE - Recreational activities involving moderate to high intensity use requiring modification of natural landforms and the provision of service facilities, playing fields or equipment. These activities include, but are not limited to, playground equipment, sports fields, surfaced courts, volleyball courts, batting cages, swimming pools, skateboard facility, skating rinks, equine-related training and riding facilities.

RECREATION, COMMERCIAL - Any recreational activity or facility in which a fee is collected or tickets are sold.

RECREATION, NON-COMMERCIAL - Any recreational activity or facility which is available at no cost; or is available as an amenity for members, employees, residents or other special populations.

RECREATION, PASSIVE - Recreational activities that do not require strenuous physical effort and may occur in a natural setting requiring minimal development, minimal alteration of vegetation, and providing areas for informal activities, including: walking, hiking, bird watching or other natural observation, photography, primitive camping, picnicking, archaeological or historic preservation, and fishing.

RECREATIONAL OUTFITTER - An establishment that provides equipment and supplies for the pursuit of recreational activities; such as canoeing, hiking, fishing or trail riding. Recreational outfitters may offer services for outdoor tourism including guide services and transportation services,

RECREATIONAL VEHICLE - A vehicle primarily designed as temporary living quarters for recreational camping, or travel use, which either has its own motive power or is mounted on or

drawn by another vehicle, including travel trailers, camping trailers, truck campers, motor homes and park vehicles.

RECYCLING DROP-OFF CENTER - A facility for the collection of waste paper, rags, scrap metal, or other discarded material; not to include used furniture and household equipment, used cars or used lumber.

REHABILITATION HOME - A building or group of buildings providing a supervised residence for persons recovering from the effects of drug or alcohol abuse, psychiatric disorders, or as a condition of their parole or probation. Such homes may provide counseling in educational, vocational, or other areas by a paid or volunteer staff and generally have 24-hour-a-day supervision. This definition does not apply to uses regulated by KRS 100.982.

RESIDENTIAL INFILL - Construction of new residential building(s) on vacant or by-passed land within the Urban Service Area.

RESTAURANT - An eating establishment where food is served and/or consumed primarily within the building and where consumption of food in motor vehicles on the premises is not encouraged.

Note: A restaurant may only include drive-through facilities (where food is served to patrons while in their motor vehicles through a window or other facilities and consumption on the premises in motor vehicles is not encouraged) as permitted and regulated in the zone in which the restaurant is located.

RESTAURANT, DRIVE-IN - An eating establishment where food is served by employees or by self-service outside the building and is consumed on the premises, principally in a motor vehicle.

RETAIL SALES ESTABLISHMENT - A commercial enterprise that provides goods and/or services directly to the consumer, where such goods are available for immediate purchase and removal from the premises by the purchaser.

RETAIL SALES ESTABLISHMENT, BULK MERCHANDISE - A retail establishment engaged in selling goods or merchandise to the general public, as well as to other retailers, contractors or businesses rendering services incidental to the sale of such goods. Bulk retail involves a high volume of sales of related and/or unrelated products in a warehouse setting and may include membership warehouse clubs. Bulk retail is differentiated from general retail by the following characteristics: items for sale include large, categorized products (e.g., lumber, appliances, household furnishings, electrical and heating fixtures and supplies, wholesale and retail nursery stock) and may also include a variety of carryout goods (e.g., groceries, household and personal care products).

RIDING STABLE - A structure or land use in which equines are kept for boarding, riding or training.

ROADSIDE STAND - A temporary structure designed or used for the display or sale of agricultural products grown on the premises upon which such a stand is located.

SATELLITE DISH ANTENNA - An accessory structure, consisting of a parabolic-shaped antenna structure used to receive television signals from satellites or other objects in terrestrial orbit.

SATELLITE DISH ANTENNA, GROUND-MOUNTED - A satellite dish antenna mounted and anchored at grade so that the distance from the highest edge of the dish to the existing grade does not exceed twelve (12) feet.

SATELLITE DISH ANTENNA, POLE-MOUNTED - A satellite dish antenna mounted and anchored to the ground by a pole so that the distance from the highest edge of the dish to the existing grade exceeds twelve (12) feet.

SATELLITE DISH ANTENNA, ROOF-MOUNTED - A satellite dish antenna mounted directly upon the roof of a structure and not attached to any appurtenance such as a chimney, tower, or spire.

SCENIC BYWAY - A state designated roadway maintained by a local government that has roadsides or view sheds of aesthetic, cultural, historical, or archaeological value worthy of preservation, restoration, protection or enhancement.

SCENIC HIGHWAY - A state designated, state-maintained roadway or highway that has roadsides or view sheds of aesthetic, cultural, historical, or archaeological value worthy of preservation, restoration, protection or enhancement.

SEASONAL ACTIVITIES - Any activity which is performed or operated temporarily during one season of a calendar year, for a period not to exceed 90 days with a maximum of two (2) times per calendar year. Such activities may include a pumpkin u-pick farm, corn maze, or the like.

SCHOOLS FOR ACADEMIC INSTRUCTION - All schools offering primarily classroom instruction with participation of teachers and students, limited to elementary, junior and middle high schools, high schools, junior colleges, colleges, theological seminaries, bible colleges, and universities; but not including business colleges, technical or trade schools.

SEXUAL ENTERTAINMENT CENTER - An establishment, not otherwise specifically defined in this Article, which makes available material, services, or entertainment appealing to adult sexual interests, including, but not limited to a bath house; swingers' club; or similar establishment if the establishment or its entertainment, services, or goods are advertised by or on behalf of the establishment in a manner patently designed to appeal to such adult sexual interests.

SPECIFIED ANATOMICAL AREAS -

- (1) Less than completely and opaquely covered:
 - (a) Human genitals;
 - (b) Pubic region;
 - (c) Buttocks;
 - (d) Female breast below a point immediately above the top of the areola;
- (2) Human male genitals in a discernibly turgid state, even if completely and opaquely covered.

SPECIFIED SEXUAL ACTIVITIES -

- (1) Human genitals in a state of sexual stimulation or arousal;
- (2) Acts of human masturbation, sexual intercourse, sodomy, oral sex (real or simulated), fondling or other erotic touching of human genitals, pubic region, buttocks or female breasts, or sexual contact between humans and animals.

SPORTSMEN'S FARM – An outdoor recreation facility for archery; paintball; skeet, trap rifle and other firearm sports.

STOCKYARD - An establishment or facility commonly known as stockyards; conducted, operated or managed for profit or nonprofit as a public market for livestock producers, feeders, market agencies and buyers; consisting of pens or other enclosures and their appurtenances, in which live cattle, sheep, swine, horses, mules, goats or other farm animals are received, held or kept for sale or shipment in commerce.

STORAGE - The keeping, either indoors or outdoors, of equipment, vehicles, or supplies used in the conduct of a trade, business, or profession.

STORY - That portion of a building, other than a cellar or mezzanine, included between the surface of any floor and the surface of the floor next above it; or, if there be no floor above it, then the space between the floor and ceiling next above it.

STREET - Any vehicular way -- a general term used to describe right-of-way, which provides a channel for vehicular and pedestrian movement between certain points in the community, which may provide for vehicular and pedestrian access to properties adjacent to it, and which may also provide space for the location of under- or above-ground utilities. Streets are classified by function as follows:

EXPRESSWAYS - Hold the first rank in the classification of streets, and are used only for movement of vehicles, providing for no vehicular or pedestrian access to adjoining properties; interchange of traffic between an expressway and other streets is accomplished by grade separated interchanges with merging deceleration and acceleration lanes, and no at-grade intersections are permitted. Express- ways generally carry higher volumes, require greater right-of-way width, and permit higher speed limits than any other class of street, and should be depressed in urban or urbanizing areas. Arterials are the only class of street which generally should be connected with expressways at interchange points.

ARTERIALS - Hold the second rank in the classification, and should be used only for the movement of vehicles, and preferably should not provide for vehicular access to adjacent properties. Interruption of traffic flow should be permitted only at street intersections, which should contain medians, deceleration lanes, and left turn storage lanes. Arterials are the link between expressways and collectors, and rank next to expressways in traffic volume, speed limit, and right-of-way width.

COLLECTORS/CONNECTORS - Hold the third rank in the classification of streets, and are used both for movement of vehicles and for providing access to adjacent properties. Access to adjoining properties should be planned and controlled so that minimum disturbance is made to the traffic moving efficiency of the collector/ connector street. Intersections should contain medians, deceleration lanes, and left turn storage lanes. Collectors/connectors are the link between arterials and local streets. Collectors/ connectors generally rank next to arterials in traffic volume, speed limit, and right-of-way width.

LOCALS - Hold the fourth rank in the classification of streets, and are used primarily for providing access to adjacent properties. Vehicles moving on these streets should have an origin or destination in the immediate vicinity, and all types of through traffic should be eliminated through initial design of its connections with other streets. Local streets are the primary link

between trip generation points (homes, offices, stores, work) and collector streets. Locals have the least right-of-way, the lowest speed limit, and the least amount of vehicular traffic. Local streets can be subdivided further into the following sub-classes:

CONTINUING STREETS - Are local streets having two open ends; each end generally connects with different streets; one or more other street may intersect it between its two open ends, and property fronts on both sides of the streets.

SERVICE ROADS - Are local streets which are parallel to a street with a higher classification on one side and are parallel to properties requiring access on the other side. A service road generally has two or more open ends, connecting at intersections with streets that run perpendicular to the service road and its adjacent street of higher classification. In this way, a service road provides an access route to properties adjacent to higher classification streets; while, at the same time, reducing the number of access points from these properties onto the higher classification street. Generally, in a given block, one or no access points are provided directly to the higher classification streets, but multiple access points are provided to the adjacent properties.

LOOP STREETS - Are local streets having two open ends; each end generally connects with the same street; no other streets generally intersect between its two ends, and property fronts on both sides of the street.

CLOSE STREETS - Close streets are one-way local streets forming a "U" shape and having two open ends; each end generally connects with the same street. Property fronts on the outside of the "U," but the interior of the "U" should be natural or landscaped open space. This interior area should generally be between fifty (50) and one hundred (100) feet wide. The close street is a neo-traditional street design used as an alternative to cul-de-sacs in areas where it is difficult to provide a through street.

CUL-DE-SAC STREETS - Are local streets having only one open end providing access to another street; the closed end provides a turnaround circle for vehicles; no other street generally intersects between the two ends, and property fronts on both sides of the street.

DEAD-END STREETS - Are similar to cul-de-sacs, except that they provide no turnaround circle at their closed end and are not permitted as streets in any proposed subdivision. Stub streets planned for future connection are not considered to be dead-end streets.

ALLEYS - Alleys generally have two open ends; each end connects with different streets, and property generally backs onto both sides of the alley. Special permission from the Commission is required whenever alleys are used.

RURAL ROADS - Rural roads are local streets providing access to properties in the Rural Service Area, as well as providing for movement between certain points in the community. A rural roadway includes a right-of-way, the street pavement, and may include paved shoulders and drainage ditches.

STRUCTURE - Anything constructed, the use of which requires permanent or continuous location on the ground, or attached to something having permanent location on the ground.

TATTOO PARLOR - A commercial establishment whose principal business activity is the practice of placing designs, letters, figures, symbols or other marks upon or under the skin of any person, using ink or other substances that result in the permanent coloration of the skin, using needles or other instruments designed to contact or puncture the skin.

TEMPORARY STRUCTURE - Anything constructed and placed on the ground without a permanent foundation and consisting of 400 square feet or more in size, the use of which is designed for use or occupancy for only 180 days or fewer per 12-month period. Any structure intended to remain in place in excess of that time period must be permitted as a permanent structure. For purposes of regulating the use of such structures, any limitation stated in this ordinance shall be calculated by the cumulative consideration of the use of any and all such structures on a single property. This use must also be consistent with the requirements and limitations, if any, of the Kentucky Building Code.

TENANT HOME - An accessory residence, located in an agricultural zone, occupied by a person other than the owner's family or the farm manager, engaged full-time in an agricultural use on the property.

TOPSOIL - The surface layer and its underlying materials that have properties capable of producing desirable reclamation and vegetation.

TOWNHOUSE - A single family attached dwelling, each dwelling designed and erected as a unit, separated from one another by a common wall, and capable of being subdivided into separate lots.

TRAILER - Any portable structure having no foundation other than wheels, jacks, or skirtings; or any vehicle so designed or constructed as to permit:

(1) temporary occupancy for dwelling or sleeping purposes;

- (2) the conduct of any business, trade, occupation, profession, or use as a selling or advertising device; or
- (3) the transportation of personal property; and including automobile trailers, campers, and tourist trailers, but not including a mobile home.

TRANSFER STATION - A facility, as defined in KRS 224.01(010), for the compacting and reloading of solid waste as defined in KRS 109.012(9) prior to its transportation to a permanent disposal site.

TREE CANOPY TOUR – A guided aerial exploration or transit of the forest canopy, most commonly by means of a series of zip lines or aerial walkways with platforms constructed within the trees generally for scenic views, education, interpretation and recreation.

TRUCK TERMINAL - Land and buildings used as a relay station for the transfer of freight from one truck to another; or for the parking or storage of semi-trailers for longer than 24 hours, including tractor and/or trailer units. The terminal cannot be used for permanent or long-term accessory storage for principal land uses at other locations. A truck terminal may include areas for the washing or repair of trucks associated with the terminal, but does not include an establishment solely for the display, rental, sale and minor repair of trucks.

VALUE-ADDED PRODUCT SALES – The sale of items that have been produced in a manner that enhances their value (such as organically), or items that have had a change in the physical state or form of the product (such as milling wheat into flour, making strawberries into jam, pressure canning vegetables, making salsa or producing honey) from an agricultural resource.

VEHICLE STORAGE YARD - A place where vehicles, which have a current vehicle registration and bear a current license plate in accordance with state law, and not used in the conduct of a trade; business; or profession are kept for 24 hours or longer. A vehicle storage yard does not include a yard for storage of dismantled or partially dismantled automobiles, storage of inoperable vehicles for longer than 60 days, a parking lot, truck terminal, automobile wrecking, or junk yards.

WALL PLANE, PRIMARY - A building wall or façade that faces the public right-of-way or street that provides the lot frontage. On through lots, corner lots or lots with multiple frontages on public rights-of-way, only one such wall plane shall be required.

WALL PLANE, REAR - A building wall or façade that is ordinarily opposite to the primary wall plane.

WALL PLANE, SIDE - A building wall or façade on the side of a structure, other than the primary or rear wall plane.

WHOLESALE ESTABLISHMENT - An establishment or place of business primarily engaged in selling and/or distributing merchandise to retailers; to industrial, institutional or professional business users; or to other wholesalers; or acting as agents or brokers and buying merchandise for, or selling merchandise to, such individuals or companies.

WHOLESALE ESTABLISHMENT WITH WAREHOUSE - The display, storage and sale of goods to other firms for resale, as well as activities involving significant movement and storage of products or equipment, including truck terminal or bus servicing facilities; motor freight transportation; moving and storage facilities; warehousing and storage activities.

WOODLOT, COMMERCIAL - Premises, or portions thereof, used for seasoning and storage of firewood and for cutting and splitting of timber to produce firewood for later resale (excluding sawmills, planing mills).

YARD, FRONT - An open space extending the full width of the lot between a building and the front lot line, unoccupied and unobstructed from the ground upward except as herein specified. The depth of a front yard is the shortest distance, measured horizontally, between any part of a building, exclusive of such parts herein excepted, and the front lot line.

YARD, REAR - An open space extending the full width of a lot between a building and the rear lot line, unoccupied and unobstructed from the ground upward except as herein specified. The depth of a rear yard is the shortest distance, measured horizontally, between any part of a building, exclusive of such parts herein excepted, and the rear lot line.

YARD, SIDE - An open space between a building and a side lot line, unoccupied and unobstructed from the ground upward, except as herein specified. The width of a side yard is the shortest distance, measured horizontally, between any part of a building, exclusive of such parts herein excepted, and the nearest side lot line.

YARD, SIDE STREET SIDE - A yard abutting the side street of a corner lot, unoccupied and unobstructed from the ground upward, except as herein specified, and extending from the front yard line to the rear lot line, and being the least distance between the lot line abutting the side street and the building.

YOUTH CAMP – A facility for the primary purpose of providing activities for children, including social, recreational, spiritual and/or educational activities, including accessory and incidental food

service, and operated for five (5) or more consecutive days during one or more seasons of the year.

ZIP LINE TRAIL – An aerial trail system providing recreation and education that enables people to traverse terrain by means of a series of zip lines and platforms supported by man-made towers or ground anchors.

ZIP LINE – A cable or rope line suspended between support structures enabling a person attached to a pulley to traverse from one point to another.

ZONE - A portion of the territory within Lexington-Fayette Urban County within which certain regulations and requirements apply under the provisions of this Zoning Ordinance.

ZONE, AGRICULTURAL – A-R, A-B, A-N or A-U zone.

ZONE, BUSINESS - B-1, B-2, B-2A, B-2B, B-3, B-4, B-5P, B-6P or CC zone.

ZONE, INDUSTRIAL - An I-1, I-2 or ED zone.

ZONE, MIXED-USE - An MU-1, MU-2 or MU-3 zone.

ZONE, RESIDENTIAL - An R-1A, R-1B, R-1C, R-1D, R-1E, R-1T, R-2, R-3, R-4, R-5, EAR-1, EAR-2, EAR-3 or PUD-1 zone.

ZOOLOGICAL GARDEN - A park-like area in which live animals are kept in cages or large enclosures for public exhibition.

Section 2 – That Article 3 of the Zoning Ordinance of the Lexington-Fayette Urban County

Government be and hereby is amended to read as follows:

GENERAL ZONE REGULATIONS

3-1 APPLICATION OF ZONE REGULATIONS - The regulations set by this Zoning Ordinance within each zone shall be minimum or maximum limitations, as appropriate to the case, and shall apply uniformly to each class or kind of structure or land, except as hereinafter provided:

- (a) No building, structure, or land shall hereafter be used or occupied; and no building or structure or part thereof shall hereafter be erected, constructed, reconstructed, moved or structurally altered except in conformity with all of the regulations herein specified for the zone in which it is located unless otherwise specifically permitted in this Zoning Ordinance.
- (b) No building or other structure shall hereafter be erected or altered:
 - (1) to exceed the height, bulk or floor area ratio;
 - (2) to accommodate or house a greater number of families;
 - (3) to occupy a greater percentage of lot area;
 - (4) to have narrower or smaller rear yards, front yards, side yards, or other open spaces; or
 - (5) to have less perimeter and interior lot landscaping for vehicular use area and non-compatible land uses than herein required, or in any other manner be contrary to the provisions of this Zoning Ordinance.
- (c) No part of a yard, open space, off-street parking, loading space or other special use area required about or in connection with any building or land, for the purpose of complying with this Zoning Ordinance, shall be included as part of a yard, open space, off-street parking, loading space or other special use area similarly required for any other building or land unless otherwise specifically permitted in this Zoning Ordinance.
- (d) No yard or lot existing at the time of adoption of this Zoning Ordinance shall be reduced in dimension or area below the minimum requirements set forth herein. Yards or lots created after the adoption of this Zoning Ordinance shall meet at least the minimum requirements established by this Zoning Ordinance.
- (e) There shall be no more than one principal structure and its accessory structures on any lot or parcel of land in an agricultural zone or in any residential zone, unless otherwise specifically permitted as a Group Residential Project or a Planned Unit Development in this Zoning Ordinance. In all other zones, more than one principal building shall be permitted only if a development plan is approved by the Commission, as provided by Article 21.
- (f) Only those uses specifically named as principal, accessory, or conditional uses or substantially similar to principal, accessory or conditional uses are permitted in each

zone. All uses not specifically permitted or substantially similar to permitted uses are prohibited. Prohibited uses shall include, but not be limited to, those specifically named as prohibited.

3-2 CONVERSION OF STRUCTURES - The conversion of any structure or structures, either residential or non-residential, so as to accommodate an increased number of dwelling units or families, or another permitted use, shall be permitted only within a zone in which a new building for similar occupancy would be permitted under this Zoning Ordinance. The resulting occupancy shall comply with all requirements governing new construction in such zone, including, but not limited to, floor area; floor area ratios; dimension of yards; open spaces; and off-street parking. The aforesaid requirements with respect to yards shall not apply if the conversion involves no exterior structural changes to a principal building, but shall apply if an accessory building is converted to a principal building.

3-3 SIGHT TRIANGLES FOR TRAFFIC VISIBILITY - Except as permitted herein, in any zone, at any street intersection, railroad crossing, or any driveway intersection, no fence, structure or planting, other than ground cover, shall be erected or installed within the sight distance triangle as shown in the table and the illustrations below.

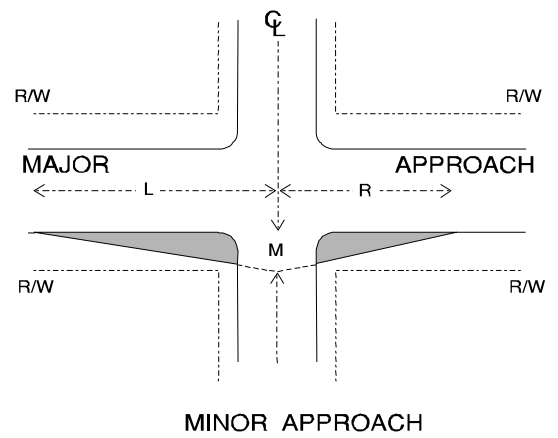

SIGHT TRIANGLES AT INTERSECTIONS *1*2*3

MINOR APPROACH

		PUBLIC OR PRIVATE	
		STREET	DRIVEWAY
M	Major	L = 325'	L = 325'
A	Arterial	R = 150'	R = 150'
J		M = 15'	M = 15'
O			
R	Minor	L = 325'	L = 275'
	Arterial	R = 150'	R = 150'
A		M = 15'	M = 15'
P			

P R O A C H	Collector	L = 200'	Non-Residential
		R = 150'	L = 200'
		M = 15'	R = 150'
			M = 15'
			Residential
			L = 150'
		R = 120'	
		M = 15'	
	Local	L = 175'	L = 75'
	Street	R = 130'	R = 55'
		M = 15'	M = 10'

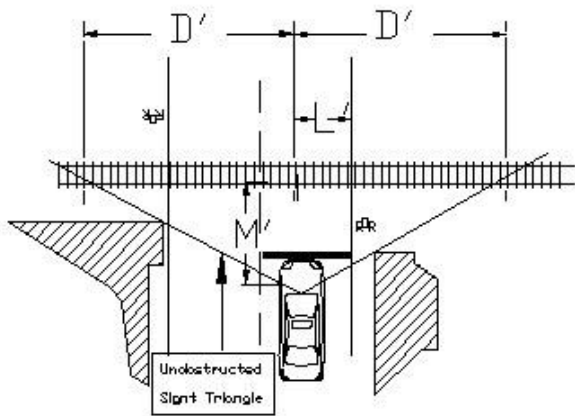

SIGHT TRIANGLES AT RAILROAD CROSSINGS *1*2*3

APPROACH

	PRIVATE OR PUBLIC STREET OR HIGHWAY	ANY TYPE OF PRIVATE DRIVEWAY
Railroad	D = 725'	D = 325'
Approach	M = 35'	M = 25'
	L = 8'	L = 6'

Where D' =	Distance along rail	Distance along rail
Where M' =	Distance from rail	Distance from rail
Where L' =	Distance from edge of pavement	Distance from edge of pavement

- *1 The table assumes right angle intersections and straight major approach movements within the sight distance. Situations involving skewed intersections, curvilinear streets and other mitigating factors shall have sight distances, as determined by the Urban County Traffic Engineer.
- *2 In the B-2, B-2A, and B-2B zones, the sight triangle may be modified at signalized intersections, as determined by the Urban County Traffic Engineer.
- *3 Wire or chain link fences may be located within the sight triangle when approved by the Division of Traffic Engineering and the Division of Building Inspection upon a finding that visibility would not be impaired.

3-4 AGRICULTURAL LAND USE EXEMPTIONS - Notwithstanding any other provision of this Zoning Ordinance, land which is used solely for agricultural use, as defined herein, shall have no regulations imposed as to building permits, certificates of occupancy, height, yard, or location requirements for agricultural buildings, except that a setback line of thirty feet shall be required for agricultural buildings for the protection of existing and proposed streets and highways; and that all buildings or structures in a designated floodway or floodplain, or which tend to increase flood heights or obstruct the flow of flood waters, may be fully regulated. Any parcel of land used for an urban agricultural use with the Urban Service Area, as defined herein, shall also be exempt from use restrictions listed in each zone, but buildings proposed for such uses shall be subject to building permit, zoning setback, floodplain setback and certificate of occupancy requirements contained herein.

3-5 FALLOUT SHELTERS - Fallout shelters, as defined by this Ordinance, shall be permitted as principal or accessory uses in all zones subject to applicable yard, height, area, and other regulations for principal or accessory structures for the zone in which such shelter is located.

3-6 MIXED-INCOME HOUSING BONUSES - Units that are designated as Mixed-Income Housing Units in order to receive either additional density, parking reductions or additional floor area shall be restricted by the developer exclusively to mixed-income housing for a minimum period of 5 years. Further, such units shall be identified separately in the Certificate of Land Use Restriction filed for the development where the units are located; and such units shall be subject to a deed restriction in favor of the Lexington-Fayette Urban County Government, which shall restrict the use of the property and shall establish monitoring procedures to ensure that the units remain affordable during the period. Affordable housing units within the defined Expansion Area shall be subject to Article 23A(2)(w).

3-7 GENERAL REGULATIONS FOR CEMETERY PROTECTION - Existing private family cemeteries shall be permitted to remain in all zones. Upon the filing of a development plan or subdivision plan, a private family cemetery shall be preserved and protected in its existing location or relocated within Fayette County unless specifically requested by family or other heirs, and shall be regulated as follows:

- (a) Disinterment and relocation of graves shall be accomplished in accordance with all applicable local and state requirements and with the knowledge and approval of the Kentucky Office of Vital Statistics.
- (b) Preservation and protection of a cemetery, either left in place or once relocated, shall be subject to the following requirements:
 - (1) No construction or disturbance of any kind shall occur within fifty (50) feet of a cemetery boundary, regardless of property lines or ownership, except as provided herein (fence, wall, access easement or landscaping).
 - (2) Screening and landscaping shall be provided as stated in Article 18-3(a)(1). If a cemetery is located on a larger tract of property, then screening shall be located adjacent to the cemetery fence inside the 50-foot buffer area.
 - (3) When a cemetery is identified on land proposed for development, the cemetery

boundary shall be established based on historic records, fence lines, gravesite locations or other criteria, as determined by a certified archeologist, prior to any construction or disturbance.

- (4) A cemetery boundary study performed by a certified archeologist shall be submitted with any development plan, preliminary subdivision plan, and minor or major subdivision plat for land with identified cemeteries or burial grounds. Such study shall include a map that portrays the location and orientation of graves within the cemetery and the associated geographic coordinates, and a written description of field and archival methods used to document the cemetery.
- (5) Any existing cemetery fence, wall and/or gate on the subject property shall be maintained and repaired prior to any site work or disturbance on any surrounding property. Where none exists, a new permanent fence shall be erected prior to any site work or disturbance on the subject property. Such fence shall be constructed of durable and weather-resistant materials (i.e., brick, stone, iron and/or steel).
- (6) A statement of maintenance and permanent ownership shall be made on any development plan.
- (7) Access shall be provided to the cemetery with a minimum 10-foot-wide access easement.

3-8 GENERAL REGULATIONS FOR VEHICLE REPAIRS ACCESSORY TO A RESIDENTIAL USE - Shall be regulated as follows:

- (a) Vehicles being repaired shall be parked/stored on a paved surface or on a permitted or legally non-conforming gravel surface if a paved surface is not available.
- (b) Major repairs shall be confined to the interior of a garage or other enclosed building, and shall not include any finish painting or clear coating operations.
- (c) At outdoor locations, including any unenclosed structure such as a carport, only minor repairs are allowed. Only one vehicle per dwelling at an outdoor location can be under repair at any given time, and repairs must be completed within three days.
- (d) Repairs are only allowed on vehicles that are registered to an occupant of the dwelling on the subject property.
- (e) Repairs may not be conducted as a business or as part of a commercial operation of any kind.
- (f) All waste oil and fluids shall be recycled or disposed of at an approved off-site location in compliance with local, state and federal environmental regulations. Auto parts and tires shall be recycled or disposed of in accordance with current LFUCG Division of Waste Management guidelines and in compliance with local, state and federal environmental regulations.

3-9 PARKING AND STORAGE OF BUSINESS VEHICLES, TRAILERS, EQUIPMENT AND MATERIALS IN RESIDENTIAL ZONES - Shall be regulated as follows:

- (a) One business vehicle per dwelling is permitted, provided it has no more than two (2) axles and a GVWR (gross vehicle weight rating) of no greater than 14,000 lbs. and is used for daily transportation to and from work. Such a vehicle must be parked on a permitted paved surface or on a legal non-conforming (existed prior to December 5, 2002) gravel surface. Dump trucks, box trucks, cube vans, high-roof cargo vans (greater than 8' height, as measured from ground to top of roof), earth-moving machinery, tow trucks, transport wreckers, semi-trucks and tractor-trailers, concession trucks and vans, and flat-bed trucks are specifically prohibited, even if they technically comply with the above limits.
- (b) One business trailer per dwelling (open or closed), used in conjunction with an allowed business vehicle, may be
- (c) parked or stored on a permitted paved surface or legal non-conforming gravel surface. Any such trailer is limited to a length of no greater than twelve (12) feet. Concession trailers are specifically excluded from this category of allowable trailers, even if they technically comply with axle and length limitations.
- (d) Trailers, equipment or materials shall not be parked or stored on any public or private street.
- (e) Construction materials (such as siding or brick) and salvaged items (such as used appliances or scrap metal) may not be stored.
- (f) Business activities (e.g., selling of merchandise or customer visits) shall not take place on the premises, except as allowed by home office provisions or as authorized by a conditional use approved by the Board of Adjustment. Corollary business activities, such as the storage of merchandise or having employees report to the property, are also prohibited.

3-10 GENERAL REGULATIONS FOR OPERATION OF A HOME OFFICE OR HOME OCCUPATION - Shall be as follows:

- (a) The use shall be clearly incidental and secondary to use for dwelling purposes with no more than three hundred (300) square feet of the dwelling devoted to each use;
- (b) The use shall be operated by and shall employ only residents of the dwelling;
- (c) No commodities or merchandise shall be stored on the property other than those produced and/or repaired by the residents on the premises;
- (d) The residence shall maintain its residential character and shall not be altered or remodeled so as to change the residential appearance of the building;
- (e) No outside signage related to the use shall be permitted on the premises;
- (f) The use shall be located in the dwelling unit and not in any accessory building;
- (g) On-site sales or visits to the home by customers, clients, patrons and the general public are not allowed;
- (h) The use does not involve firearms or potentially disturbing equipment, materials or chemicals.

These provisions are not intended to restrict offices accessory to principal permitted agricultural uses located in homes on the same agricultural property.

Home office shall not include offices for escort services.

3-11 GENERAL REGULATIONS FOR OPERATION OF A HOME-BASED BUSINESS – Shall be as follows:

- (a) All activities shall comply with the provisions outlined in 3-10(a) through (f) above;
- (b) Any conditions regarding the use of firearms or potentially disturbing equipment, materials or chemicals (e.g., soundproofing or other safety measures) shall be as determined to be appropriate by the Board of Adjustment;
- (c) Limitations on hours of operation and frequency of customer/client visits shall be as determined to be appropriate by the Board of Adjustment;
- (d) No additional paving for parking shall be permitted.
- (e) The use does not adversely affect surrounding properties by excessive traffic generation, noise or odors that might be associated with equipment, materials or chemicals used in the operation of the home-based business.

Section 3 – That Article 8 of the Zoning Ordinance of the Lexington-Fayette

Urban County Government be and hereby is amended, in part, to read as follows:

SCHEDULE OF ZONES

The following zones and their requirements appear in the Schedule of Zones included therein:

<u>Section</u>	<u>Zone</u>	<u>ZoneTitle</u>
8-1	A-R	Agricultural Rural
8-2	A-B	Agricultural Buffer
8-3	A-N	Agricultural Natural Areas
8-4	A-U	Agricultural Urban
8-5	R-1A	Single Family Residential
8-6	R-1B	Single Family Residential
8-7	R-1C	Single Family Residential
8-8	R-1D	Single Family Residential
8-9	R-1E	Single Family Residential
8-10	R-1T	Townhouse Residential
8-11	R-2	Two-Family Residential
8-12	R-3	Planned Neighborhood Residential

8-13	R-4	High Density Apartment
8-14	R-5	High Rise Apartment
8-15	P-1	Professional Office
8-16	B-1	Neighborhood Business
8-17	B-2	Downtown Business
8-18	B-2A	Downtown Frame Business
8-19	B-2B	Lexington Center Business
8-20	B-3	Highway Service Business
8-21	B-4	Wholesale and Warehouse Business
8-22	I-1	Light Industrial
8-23	I-2	Heavy Industrial
8-24	P-2	Office, Industry and Research Park

8-1 AGRICULTURAL RURAL (A-R) ZONE

8-1(a) Intent - This zone is established to preserve the rural character of the agricultural service area by promoting agriculture and related uses, and by discouraging all forms of urban development except for a limited amount of conditional uses.

8-1(b) Principal Uses (Other uses substantially similar to those listed herein shall also be deemed permitted.)

1. Land used solely for agricultural purposes, including small farm wineries and equine-related activities, as outlined in KRS 100.
2. Single family detached dwellings.

8-1(c) Accessory Uses (Uses and structures which are customarily accessory, clearly incidental and subordinate to permitted uses.)

1. Accessory uses in connection with agriculture, farming, dairying, stock raising or similar uses, such as agricultural structures; stables; farm tours; hayrides; petting zoos; and parking areas, provided all yard requirements for a principal residence are met.
2. Those specific agricultural uses outlined in KRS 100 that are incidental only to a small farm winery licensed as such by the Commonwealth of Kentucky, such as the manufacture and bottling of wines; tasting rooms for the purpose of serving complimentary samples; sale by the drink or bottle, either on or off premises; and sale and shipment of wine, either wholesale or retail.
3. Home offices and home occupations.
4. Temporary roadside stands offering for sale only agricultural products grown on the premises, or value-added product sales primarily from agricultural resources grown or raised on the premises.
5. Keeping of not more than two (2) roomers or boarders by a resident family.
6. Non-commercial recreational facilities, such as baseball fields; soccer fields; polo fields; swimming pools; tennis courts; bicycling and hiking trails and the like.
7. Private garages, storage sheds, parking lots, and private farm vehicle fueling facilities.
8. Living quarters, without kitchen facilities and not used for rental purposes, for guests and employees of the premises.
9. Satellite dish antennas, as regulated in Article 15-8.
10. Family child care for up to six (6) children, provided that the total number of children living or being cared for on the premises shall not exceed six (6).
11. Mobile homes, as provided in Article 10.
12. Tenant homes, provided all yard requirements for a principal residence are met.

8-1(d) Conditional Uses (Permitted only with Board of Adjustment approval.)

1. Horse race tracks with allotted race meets, including accessory simulcast facilities, accessory restaurants and/or the serving of alcoholic beverages, and horse riding and training facilities.

2. Horse sales establishments.
3. Hospitals for large animals, including equine hospitals.
4. Plant nurseries.
5. Commercial greenhouses, but only when all the following conditions are met:
 - a. A 20-foot wide landscape easement shall be provided around all buildings and parking areas or at the perimeter of the tract of land, containing one tree per thirty (30) feet of length or fraction thereof, plus a continuous 6-foot high planting, hedge, fence, wall or earth mound. Plantings shall be both deciduous and non-deciduous. A detailed site plan showing proposed screening shall be provided, and a performance bond or letter of credit shall be posted with the Division of Building Inspection to ensure completion of screening. New screening shall not be required to be planted when existing screening is substantially similar to the screening mentioned above.
 - b. No structure shall be built within three hundred (300) feet of any existing residential structure on another lot under different ownership, and driveways shall be one hundred (100) feet from property lines.
 - c. There shall be no outdoor display or sale of fungicides, insecticides, chemicals, peat moss, humus, mulches or fertilizer.
 - d. No commercial greenhouse shall be located within a floodplain.
 - e. The commercial greenhouse shall be located where easily accessible by arterial roads. All roads to the site should be of sufficient width and constructed to safely handle all sizes of trucks. The Board shall review the location of access points to ensure that no traffic hazards are created.
 - f. All driveways and parking areas shall be paved or sealed to prevent dust.
6. Commercial composting, but only when the following conditions are met:
 - a. That only the open windrow or static pile method of aerobic processing using plant material, soils and animal manure, be permitted.
 - b. That a permit-by-rule or letter of intent from the Division of Waste Management of the Kentucky Natural Resources and Environmental Protection Cabinet be obtained prior to submission of any application to the Board of Adjustment for a conditional use permit.
 - c. That no commercial composting operation be conducted closer than one thousand (1,000) feet to any existing residence.
 - d. That a development plan indicating access points and circulation routes, proposed signage, screening and landscaping, fencing and other significant geological or physical features of the property be submitted as part of any application.
 - e. That the Board specifically consider and be able to find that the proposed use will not constitute a public nuisance by creating excessive noise, odor, traffic or dust.
7. Agricultural market, but only when the following conditions are met:
 - a. The minimum lot size shall be forty (40) acres and shall not be located in A-R zoned land within the Urban Service Area of Lexington-Fayette County.
 - b. The property shall be within one (1) mile of an interstate interchange with a state or federal highway, excluding the two interchanges of Interstate 64 with Interstate 75. The property must also have frontage on a state or federal highway, and access is also to be within one (1) mile of the point of intersection of the centerlines of the interchange, and subject to approval by the Kentucky Transportation Cabinet.
 - c. All roads to the property shall be of sufficient width, and constructed to safely handle all sizes of trucks when fully loaded during all weather conditions.
 - d. The facility shall be at least one thousand (1,000) feet from any property in a residential zone, any property designated as a Rural Settlement (RS) or as an Existing Rural Residential (ERR) land use under the adopted Comprehensive Plan, and any property designated on the National Register of Historic Places. As used herein, "facility" shall mean all improvements, including parking and loading areas, but not including driveways for ingress and egress to the property.
 - e. Improvements such as buildings; barns; and other structures, including storm water detention basins, truck parking and loading areas; above-ground and underground storage tanks and septic sewage disposal systems shall be located outside of any environmentally sensitive area, including any wellhead protection area.
 - f. All sales and marketing of livestock shall take place in a completely enclosed facility, and no building may be located closer than one thousand (1,000) feet from a residence on a lot under different ownership; provided, however, that all pre-sale and post-sale handling of livestock shall take place under roof in a facility enclosed by a combination of fences and gates in order to secure the livestock while allowing adequate ventilation and air circulation.
 - g. There shall be provision for the treatment and/or disposal of waste generated on the site, subject to all applicable local, state and federal requirements. Muck piles or the spreading of animal waste upon any part of the site shall be prohibited.
 - h. All parking areas and driveways shall be paved.
 - i. Any outdoor lighting proposed must be directed away from, and shielded from,

- adjacent agricultural and/or residential areas.
- j. The facility shall be operated at all times in compliance with applicable federal, state and local laws and regulations, including those pertaining to noise, air and water quality.
 - k. Storm water management shall be provided pursuant to the requirements of the LFUCG Engineering Manuals, and storm water shall be treated appropriately prior to its discharge.
 - l. Screening shall be provided if the facility is visible from adjoining properties. Such screening and buffering shall be designed so as to minimize the impact of air, noise, odor and/or light generated by the facility upon adjoining properties to the greatest extent practicable. Article 18 of the Zoning Ordinance shall be used to guide the planting of the screening of loading docks and vehicular use areas, but the Board of Adjustment may impose additional screening requirements and landscape buffers, as necessary.
 - m. There shall be a minimum of forty-five percent (45%) of the lot, regardless of size, provided as open space, which may not be varied by the Board of Adjustment.
 - n. The following accessory uses may also be permitted in conjunction with the operation of an agricultural market, provided that the aggregate of these uses may not exceed twenty-five percent (25%) of the total square footage of buildings on the property, or 40,000 square feet, whichever is less; and, except as otherwise provided, shall be located in the principal structure on the property, provided they are operated primarily for the benefit of patrons and employees of the agricultural market; provided that no signs identifying such uses are visible from the right-of-way; and provided that all such uses are clearly identified on the site plan submitted to the Board of Adjustment:
 - 1) Accessory offices for banking, insurance and financial institutions;
 - 2) Meeting rooms, not to exceed five percent (5%) of the total floor area;
 - 3) One (1) coffee shop or restaurant, not to exceed 5,000 square feet, or five percent (5%) of the total floor area, whichever is less;
 - 4) Loading docks;
 - 5) State and federal government offices related to agriculture;
 - 6) Veterinary clinic, including the sale of livestock pharmaceutical supplies;
 - 7) One (1) dwelling unit for owners, operators or employees; and one (1) dwelling unit for watchmen or caretakers, which dwelling units may be separate structures;
 - 8) Retail sale of agricultural products, supplies and related items, including the acceptance of orders for bulk agricultural supplies, with no on-site storage of such supplies, not to exceed 5,000 square feet;
 - 9) Sale of agricultural products produced on the premises;
 - 10) Livestock and grain commodity trading office;
 - 11) Display area for farm machinery/ equipment, provided that no on-site sales shall be permitted.
 - o. A detailed development plan, indicating access points, including construction and circulation routes; parking areas; lighting; screening and landscaping; proposed improvements; accessory uses; detention areas; signage; fencing and other significant physical or geological features of the property shall be submitted as part of any application.
 - p. One free standing sign per street frontage may be permitted, limited to the agricultural market and not any use accessory thereto, with a maximum of two (2) signs, not exceeding 50 square feet in area and 20 feet in height. In addition to any free standing sign, wall-mounted signs may also be permitted, not to exceed a total of five percent (5%) of the wall area to which they are attached; provided the signs are for the agriculture market and not for the purposes of identification of any use accessory thereto. Signs may only be non-illuminated or indirectly illuminated.
 - q. An operational plan shall also be submitted that outlines:
 - 1) Provisions for animal and/or product waste disposal, including grease, subject to all applicable local, state and federal requirements.
 - 2) Provisions for sewage disposal, maintaining air and water quality, and odor management.
 - 3) Hours of operation, and anticipated hours for truck deliveries and truck shipments.
 - 4) Routing of trucks on the site, including truck stacking, parking and loading areas.
 - 5) Protection measures proposed for any environmentally sensitive area located on the site, including any wellhead protection area.
 - 6) Existing and proposed utilities.
 - 7) Where appropriate, a Kentucky No Discharge Operational Permit (KNDOP), or other appropriate permit from the Kentucky Division of Water may be required as part of the approval of an Operational Plan.
 - 8) Any other pertinent information to indicate clearly the orderly operation proposed.
 - r. The Board of Adjustment shall specifically consider and be able to find that the

proposed use will not constitute a nuisance by creating excessive noise, water pollution, traffic, dust or other public health hazards.

- s. The Board of Adjustment shall review all accessory uses approved as part of an application, on an annual basis, to ensure that such uses are operating in compliance with the restrictions set forth herein, and with any additional restrictions and/or conditions imposed by the Board. The Board may modify or revoke its approval of an accessory use if it finds, based upon the evidence, that such accessory use has been operated in violation of this Ordinance or any conditions or restrictions imposed by the Board.

8. Home-based businesses.

For any of the following conditional uses established after January 26, 1995, a total of 10,000 square feet shall be the maximum allowable for all structures proposed for such uses.

9. Cemeteries, crematories, columbariums, mausoleums, including animal burial grounds.
10. Rehabilitation homes.
11. Non-service facilities of public utilities and common carriers by rail, including office, garage, and warehouse space when not incidental to a service facility as provided in KRS 100.324.
12. Commercial and non-commercial outdoor recreational facilities (without outdoor lighting, loud speakers, retail sales of merchandise, restaurants or food service, and the like), including zoological gardens, sportsmen's farms (including outdoor rifle and other firearm ranges), native animal game preserves, outdoor rodeos, hunting and trapping, and fishing lakes, including private clubs for only these uses.
13. Commercial and non-commercial outdoor recreational facilities (excluding golf courses), with outdoor lighting; but without loud speakers, retail sales of merchandise, restaurants or food service, and the like; but only when located immediately adjacent to the Blue Sky Rural Activity Center defined in the adopted Comprehensive Plan.
14. Extraction of crude petroleum or natural gas and mining of metal, anthracite, lignite or bituminous coal.
15. Mining and/or quarrying of non-metallic minerals, but only when the proposal complies with the requirements of the Mining/Quarrying Ordinance (Code of Ordinances #252-91) and the conditions and requirements as set forth therein. The Board of Adjustment shall specifically consider and be able to find:
 - a. That the proposed use will not constitute a public nuisance by creating excessive noise, odor, traffic, dust, or damage to the environment or surrounding properties;
 - b. That a reasonable degree of reclamation and proper drainage control is feasible; and
 - c. That the owner and/or applicant has not had a permit revoked or bond or other security forfeited for failure to comply with any Federal, State or local laws, regulations or conditions, including land reclamation, pertaining to the proposed use.
16. Airports, including accessory restaurants and/or the serving of alcoholic beverages.
17. Radio, telephone or television transmitting or relay facilities, including line-of-sight relays and towers, except as permitted by KRS 100.324, and only under the following conditions:
 - a. Such facilities shall be operated at all times in compliance with applicable Federal, State, and local laws and regulations, including all standards of the Federal Aviation Administration and the Federal Communications Commission.
 - b. No transmitting or relay tower shall be located closer than the height of the tower from another lot under different ownership, or any public or private street or highway, unless the tower is constructed to withstand a minimum wind speed of one hundred (100) miles per hour.
 - c. The plans of tower construction shall be certified by an engineer registered in the State of Kentucky.
 - d. All towers shall be equipped with an anti-climbing device or fence to prevent unauthorized access.
18. Kindergartens and nursery schools for four (4) and not more than twelve (12) children, only when accessory to a residential use. A fenced and screened play area shall be provided, which shall contain not less than twenty-five (25) square feet per child.
19. Family child care for seven (7) and not more than twelve (12) children, provided that the total number of children living or being cared for on the premises shall not exceed twelve (12). A fenced outdoor play area shall be provided, which shall contain not less than twenty-five (25) square feet per child.
20. Places of religious assembly which may be allowed an additional 10,000 square

feet of building over and above their existing square footage, provided that the structure(s) existed or the religious entity had approval of the Board of Adjustment and owned 20 or more contiguous acres prior to the adoption of the Rural Land Management Plan on April 8, 1999.

21. Schools for academic instruction, including accessory dormitories.
22. Kindergartens, nursery schools and child care centers for four (4) or more children when accessory to a place of religious assembly or school, as permitted herein. A fenced and screened play area shall be provided, which shall contain not less than twenty-five (25) square feet per child.
23. Concrete mixing, but only when associated with mining or quarrying operations which comply with the requirements of the Mining/Quarrying Ordinance (Code of Ordinances #252-91) and the conditions and requirements as set forth therein, and only under the following conditions:
 - a. That no concrete mixing and/or asphalt plant operation be conducted closer than one thousand (1,000) feet from any existing residence on another lot under different ownership.
 - b. Noise, Air & Water Quality - The facility shall be operated at all times in compliance with applicable Federal, State and local laws and regulations on noise, air, and water quality, including the LFUCG Noise Ordinance (Sections 14-70 through 14-80), Article 6-7: Stormwater Disposal Standards, and Chapter 16 of the Code of Ordinances.
 - c. Development Plan - The development plan shall indicate all existing contours, shown with intervals sufficient to show existing drainage courses, retention, storm water and sedimentation basins; and the names and locations of all streams, creeks, or other bodies of water within five hundred (500) feet.
 - d. Drainage and Erosion Control - The facility shall have adequate drainage, erosion, and sediment control measures incorporated in the site/development plan(s). If, in the event adequate drainage, erosion, and sediment control cannot be provided, permits may be denied.
 - e. Roads - All access roads that intersect with a State highway or public street shall be paved with an all-weather surface of either asphalt or concrete for the entire length of road from State highway or street to the active loading point. Internal roads may be unpaved, provided dust is adequately controlled.
 - f. Screening - Screening shall be provided as defined in accordance with LFUCG Article 18 of the Zoning Ordinance.
 - g. Transportation Plan - A Transportation Plan shall be planned (in relationship to the arterial roadway system) to minimize the impact of traffic, dust, and vehicle noise on areas outside the site and shall include the following information:
 - 1) Product shipping and deliveries;
 - 2) Mode of transportation;
 - 3) Route(s) to and from site;
 - 4) Schedule and frequency of shipments;
 - 5) Delivery and shipping spillage control methods;
 - 6) Employee parking.
 - h. Storage - Storage and/or stockpiles of hazardous materials shall be in a completely closed building. Outdoor storage, except aggregate, sand and recycled asphalt material, shall be enclosed on at least three sides by a solid wall or fence, not less than six (6) feet nor greater than eight (8) feet in height, and shall be placed at designated site(s) on the development plan. At the cessation of operation, all storage piles and/or stockpiles shall either be removed or graded and covered with a minimum of 18 inches of topsoil and/or other soil-making materials, and planted in accordance with Article 18 of the Zoning Ordinance.
 - i. Excess Product and Waste - Excess product and waste, when disposed of on site, shall be in a designated area so as to prevent erosion and contamination of streams and waterways. At the cessation of operation, all outdoor storage piles and/or stockpiles shall either be removed or graded and covered with a minimum of 18 inches of topsoil and/or other soil-making materials, and planted in accordance with Article 18 of the Zoning Ordinance.
24. Asphalt plant, but only when associated with mining and/or quarrying which comply with the requirements of the Mining/Quarrying Ordinance (Code of Ordinances #252-91) and the conditions and requirements as set forth therein, and only under the following conditions:
 - a. That no asphalt plant operation be conducted closer than one thousand (1,000) feet from any existing residence on another lot under different ownership.
 - b. Noise, Air & Water Quality - The facility shall be operated at all times in compliance with applicable Federal, State, and local laws and regulations on noise, air, and water quality, including the LFUCG Noise Ordinance (Sections 14-70 through 14-80), Article 6-7: Stormwater Disposal Standards, and Chapter 16 of the Code of Ordinances.
 - c. Development Plan - The development plan shall indicate all existing contours, shown with intervals sufficient to show existing drainage courses, retention, stormwater and sediment basins; and the names and locations of all streams, creeks, or other bodies of water within five hundred (500) feet.

- d. Drainage and Erosion Control - The facility shall have adequate drainage, erosion, and sediment control measures incorporated in the site/development plan(s). If, in the event adequate drainage, erosion, and sediment control cannot be provided, permits may be denied.
 - e. Roads - All access roads that intersect with a State highway or public street shall be paved with an all-weather surface of either asphalt or concrete for the entire length of road from State highway or street to the active loading point. Internal roads may be unpaved, provided dust is adequately controlled.
 - f. Screening - Screening shall be provided as defined in accordance with LFUCG Article 18 of the Zoning Ordinance.
 - g. Transportation Plan - A Transportation Plan shall be planned (in relationship to the arterial roadway system) to minimize the impact of traffic, dust, and vehicle noise on areas outside the site and shall include the following information:
 - 1) Product shipping and deliveries;
 - 2) Mode of transportation;
 - 3) Route(s) to and from the site;
 - 4) Schedule and frequency of shipments;
 - 5) Delivery and shipping spillage control methods;
 - 6) Employee parking.
 - h. Storage - Storage and/or stockpiles of hazardous materials shall be in a completely closed building. Outdoor storage, except aggregate, sand and recycled asphalt material, shall be enclosed on at least three sides by a solid wall or fence, not less than six (6) feet nor greater than eight (8) feet in height, and shall be placed at designated site(s) on the development plan. At the cessation of operation, all storage piles and/or stockpiles shall either be removed or graded and covered with a minimum of 18 inches of topsoil and/or other soil-making materials, and planted in accordance with Article 18 of the Zoning Ordinance.
 - i. Excess Product and Waste - Excess product and waste, when disposed of on site, shall be in a designated area so as to prevent erosion and contamination of streams and waterways. At the cessation of operation, all outdoor storage piles and/or stockpiles shall either be removed or graded and covered with a minimum of 18 inches of topsoil and/or other soil-making materials, and planted in accordance with Article 18 of the Zoning Ordinance.
25. Commercial woodlots, but only when the following conditions are met:
- a. A 50-foot open space area shall be required from the perimeter of the tract of land.
 - b. No commercial woodlot shall be located within four hundred (400) feet of any residential structure on another lot under different ownership, and driveways shall be a minimum of one hundred (100) feet from property lines.
 - c. A 20-foot wide landscape buffer area shall be provided around all commercial woodlots or at the perimeter of the tract of land, containing one tree per thirty (30) feet of length or fraction thereof, plus a continuous 6-foot high planting hedge, fence, wall or earth mound. New screening shall not be required to be planted when existing screening is substantially similar to the screening mentioned above.
 - d. There shall be no storage or sale of wood chips, peat moss, humus, mulches or fertilizer, nor sale to the public of firewood at the site.
 - e. No commercial woodlot shall be located within a floodplain or sinkhole.
 - f. Commercial woodlots shall be located where easily accessible by Federal or State highways. All roads to site should be of sufficient width and constructed to safely handle all sizes of trucks. The Board shall review the location of access points to ensure that no traffic hazards are created.
 - g. All driveways and parking areas shall be paved or sealed to prevent dust.
 - h. Wood shall be stored in rows no greater than ten (10) feet in height, no greater than twenty (20) feet in width, and spaced no less than fifteen (15) feet apart.
 - i. Cutting and splitting of timber shall not occur in the 50-foot open space area of the site, and only between the hours of 8:00 a.m. - 5:00 p.m.
 - j. The Board of Adjustment shall specifically consider and be able to find that the proposed use will not constitute a public nuisance by creating excessive noise, water pollution, traffic, dust or other public health hazards.
 - k. No signage shall be permitted on the premises.
 - l. Woodlots shall comply with all applicable Federal and State laws.
26. Bed and breakfast facilities, limited to the rental of not more than five (5) rooms per property, provided that no use permitted under this section shall be located less than one (1) mile, as measured from the facility, from another use permitted under this section. The Board of Adjustment, in considering approval of such conditional use, shall consider and make a finding that the number of rooms granted shall not have an adverse effect on surrounding properties. In addition, in considering such a conditional use, the Board of Adjustment shall take into consideration the number of bed and breakfast facilities, if any, within the general neighborhood of the property being considered for such use.
27. Expansion of golf courses in existence or approved as of January 26, 1995 (including private clubs) with or without driving ranges, including the accessory

retail sale of golf-related merchandise, and including an accessory restaurant and/or food service with or without the serving of alcoholic beverages. This use shall not be conducted in conjunction with more than one single family detached dwelling.

28. Any uses that are clearly incidental and subordinate to a small farm winery operation licensed as such by the Commonwealth of Kentucky, other than those specifically outlined in KRS 100, and permitted by Article 8-1(c)(2), which may include special events with or without live entertainment or a small bistro/restaurant of up to (2) seats per 1,000 gallons of wine, brandies and cordials produced or compounded on site per year. For special events, documentation shall be provided that arrangements have been made with the LFUCG Division of Fire and Emergency Services for approval of fire suppression and control; that Fayette County Health Department approval has been obtained for the septic system and/or portable toilets; that Fayette County Health Department approval has been obtained for any food services offered, whether it be provided on site or catered for each event; and that approval be obtained from the Division of Building Inspection for any temporary structures used (i.e., tents).
29. Historic House Museum operated by a governmental entity or by a private, non-profit entity that has Internal Revenue Code Section 501(c)(3) status and that is a member of a recognized museum association such as the Kentucky Museum and Heritage Alliance, the American Association for State and Local History, the American Association of Museums, the Association of Living History, Farm and Agricultural Museums and/or Southeastern Museum Conference; provided, however, that the house shall not be expanded beyond its current or documented historic footprint, and all activities and events shall relate to the educational mission of the governmental or non-profit entity.
30. Agritourism activities to include corn mazes; farm gift shops (limited to 500 square feet); educational classes related to agricultural products or skills; horse shows involving more than 70 participants; and seasonal activities.
31. Ecotourism activities to include equine trails; botanical gardens; and nature preserves.
32. Youth camps.

8-1(e) Prohibited Uses (All uses other than those listed as principal, accessory, or conditional uses or substantially similar to principal, accessory, or conditional uses shall be prohibited. The uses below are provided for illustration purposes and for the purpose of limiting permitted uses, and are not intended to be a total listing of all the uses that are prohibited.)

1. Establishments for the processing of crude petroleum, natural gas, or oil shale.
2. Disposal of garbage and refuse, transfer stations.
3. Multi-family, two-family or townhouse dwelling units.
4. Retail sales or services, wholesale, or warehouse uses, except as provided herein.
5. Offices, museums and institutional uses.
6. Commercial recreational facilities, such as amusement parks; bowling alleys; skating rinks; pool or billiard halls; establishments with coin-operated pool or billiard tables, or outdoor theaters.
7. Hotels, motels, boarding or lodging houses, and campgrounds.
8. Manufacturing, compounding, assembling, processing and packaging and other industrial uses.
9. Automobile, truck, ATV, motorcycle, bicycle motocross, or other vehicle or bicycle race tracks.
10. Garden centers or market gardens, except those activities specifically allowed under the definition of commercial greenhouses and plant nurseries.
11. Major or minor automobile and truck repair.
12. Automobile service stations.
13. Storage, except as permitted herein.
14. Junk yards.
15. Sale of new or used merchandise, except as provided herein.
16. Slaughterhouses.
17. Penal or correctional institutions.
18. Sawmills.
19. Commercial kennels.
20. Hospitals, nursing homes, rest homes, orphanages, community residences.
21. Sewage disposal plants.
22. Fraternity and sorority houses.
23. Private clubs, including accessory restaurants and/or the serving of alcoholic beverages, except as permitted herein.
24. Adult entertainment establishments or other similar adult uses.
25. Special events, parties, festivals, concerts, and children's rides related to a commercial purpose.
26. Commercial hiking, bicycling and zip line trails; tree canopy tours; canoeing and kayaking launch sites; or recreational outfitters.
27. Commercial farm markets.

Lot, Yard and Height Requirements (See Articles 3 and 15 for additional regulations.)

8-1(f) Minimum Lot Size - Forty (40) acres, except as noted in 8-1(o)(1) below.

8-1(g) Minimum Lot Frontage - 750', except as noted in 8-1(o)(1) below.

8-1(h) Minimum Front Yard - 300' from the right-of-way line, except for the following:

- (1) Lots which have principal permitted residential structures less than 300' from the right-of-way line; then the minimum front yard shall be coincident with the existing front yard, or 50', whichever is greater;
- (2) Lots which were created by subdivision plats recorded prior to January 26, 1995 shall have the minimum front yard coincident with the platted building line, or 50', whichever is greater;
- (3) Existing lots less than 350' in lot depth shall have the minimum front yard coincident with the platted building line, or 50', whichever is greater.

8-1(i) Minimum Each Side Yard - 25 feet.

8-1(j) Minimum Rear Yard - 25 feet.

8-1(k) Minimum Useable Open Space - No limitation.

8-1(l) Maximum Lot Coverage - No limitation.

8-1(m) Maximum Height of Building - 35 feet, except for buildings devoted solely to agricultural uses, then no limitation.

8-1(n) Off-Street Parking (See Article 16 for additional parking regulations.)

Bed and Breakfast Facilities - One space per room rented other than the first room.

Places of Religious Assembly - One (1) space for each five (5) seats in the main auditorium, with a minimum of five (5) spaces.

Commercial Greenhouses - Provided there are sales to the public on the premises, one (1) space per employee, and ten (10) additional spaces, plus one (1) additional space per four hundred (400) square feet of total floor area, up to five thousand (5,000) square feet of total floor area. Parking spaces not required to be paved, but must be durable and dustless.

Non-Commercial Outdoor Athletic Facilities, including Baseball Fields; Soccer Fields; Outdoor Rodeos - One (1) space for every five (5) spectator seats, or one for every three active participants in the sport, whichever is greater.

Commercial and Non-Commercial Riding Stables, Fishing Lakes, Sportsmen's Farms, Zoological Gardens, and Other Recreational Facilities, Ecotourism and Agritourism activities not otherwise stated herein - Five (5) spaces, plus one (1) space for each employee for each separate use.

Dormitories - Five (5) spaces, plus one (1) space for every five (5) beds.

Dwelling Units - One (1) parking space per dwelling unit.

Elementary and Junior High Schools - One (1) space for every fifteen (15) seats in the main auditorium; or one (1) space for every classroom, plus one (1) space for each employee, whichever is greater.

All Other Schools for Academic Instruction - One (1) space for each five (5) classroom seats, or one space for each five (5) seats in the main auditorium, whichever is greater.

Equine Hospitals or Large Animal Hospitals - One (1) space per four hundred (400) square feet of floor area, with a minimum of five (5) spaces; but not including any barns.

Golf Courses - Three (3) spaces for every hole on the main course.

Golf Driving Ranges - One (1) space per driving tee; plus one (1) space per employee, with a minimum of five (5) spaces.

Horse Race Tracks - One (1) space per five (5) seats, plus one (1) space for every three (3) employees.

Rehabilitation Homes - One (1) space for each three (3) beds; plus one (1) space for

each employee on the maximum shift, with a minimum of five (5) spaces.

Kindergartens, Nursery Schools, Child Care Centers and Family Child Care for seven (7) or more children - Three (3) spaces for the first twelve (12) children, plus one space for every ten (10) (or fraction thereof) additional children.

Private Clubs - One (1) space for every four (4) members.

Small Farm Winery Restaurant/Bistro - One (1) space for every six (6) seats in the restaurant or bistro.

Conditional Uses - Parking requirements stated herein for conditional uses are minimum requirements; the Board of Adjustment may establish additional requirements, as needed. For any conditional use not otherwise stated herein: one (1) space per employee, with a minimum of five (5) spaces.

Combinations - Combined uses shall provide parking equal to the sum of the individual requirements.

8-1(o)Special Provisions

1. Existing single family residential structures containing, at a minimum, running water; indoor plumbing; and electricity; and which has been legally occupied at any time within six months of the date of the adoption of this section, may be subdivided from its parent tract on a 10-acre minimum lot with a minimum of 250' of lot frontage, provided that the remaining parent tract has a minimum of 40 acres, and at least 250' of frontage on an existing road; or approved access as provided for in Article 6-8(1) of the Land Subdivision Regulations. The provisions of this section shall expire three years from the date of its adoption.

8-2 AGRICULTURAL BUFFER (A-B) ZONE

8-2(a)Intent - This zone is established to preserve the rural character of the agricultural service area by establishing agricultural land that can serve as buffer areas between urban uses and agricultural land, and between land outside Fayette County and agricultural uses. It is the intent of this zone to provide separation between conflicting uses by requiring appropriate landscaping, fencing, and compatible uses. The Land Use Element of the Comprehensive Plan shall be used to determine the appropriate location for the Agricultural Buffer (A-B) zone.

8-2(b)Principal Uses (Other uses substantially similar to those listed herein shall also be deemed permitted.)

1. Land used solely for agricultural purposes, including small farm wineries and equine-related activities, as outlined in KRS 100.
2. Single family detached dwellings.

8-2(c)Accessory Uses (Uses and structures which are customarily accessory, clearly incidental and subordinate to permitted uses.)

1. Accessory uses in connection with agriculture, farming, dairying, stock raising or similar uses, such as agricultural structures; stables; farm tours; hayrides; petting zoos; and parking areas, provided all yard requirements for a principal residence are met.
2. Those specific agricultural uses outlined in KRS 100 that are incidental only to a small farm winery licensed as such by the Commonwealth of Kentucky, such as the manufacture and bottling of wines; tasting rooms for the purpose of serving complimentary samples; sale by the drink or bottle, either on or off premises; and sale and shipment of wine, either wholesale or retail.
3. Home offices and home occupations.
4. Temporary roadside stands offering for sale only agricultural products grown on the premises, or value-added product sales primarily from agricultural resources grown or raised on the premises.
5. Keeping of not more than two (2) roomers or boarders by a resident family.
6. Non-commercial recreational facilities, such as baseball fields; soccer fields; polo fields; swimming pools; tennis courts; bicycling and hiking trails and the like.
7. Private garages, storage sheds, parking lots, and private farm vehicle fueling facilities.
8. Living quarters, without kitchen facilities and not used for rental purposes, for guests and employees of the premises.
9. Satellite dish antennas, as regulated in Article 15-8.
10. Family child care for up to six (6) children, provided that the total number of children living or being cared for on the premises shall not exceed six (6).

11. Mobile homes, as provided in Article 10.
12. Tenant homes, provided all yard requirements for a principal residence are met.

8-2(d) Conditional Uses (Permitted only with Board of Adjustment approval.)

1. Hospitals for large animals, including equine hospitals.
2. Plant nurseries.
3. Home-based businesses.

For any of the following conditional uses established after January 26, 1995, except where the A-B zone is adjacent to the county boundary, and the property is a minimum of 10 acres and has frontage on a state highway, a total of 10,000 square feet shall be the maximum allowable for all structures proposed for such uses.

3. Cemeteries, crematories, columbariums, mausoleums, including animal burial grounds.
4. Rehabilitation homes.
5. Non-service facilities of public utilities and common carriers by rail, including office, garage, and warehouse space when not incidental to a service facility as provided in KRS 100.324.
6. Commercial and non-commercial outdoor recreational facilities (without outdoor lighting, loud speakers, retail sales of merchandise, restaurants or food service, and the like). including zoological gardens; sportsmen's farms (including outdoor rifle and other firearm ranges); native animal game preserves; outdoor rodeos; hunting and trapping; primitive campgrounds; and fishing lakes; including private clubs for only these uses.
7. Extraction of crude petroleum or natural gas and mining of metal, anthracite, lignite or bituminous coal.
8. Mining and/or quarrying of non-metallic minerals, but only when the proposal complies with the requirements of the Mining/Quarrying Ordinance (Code of Ordinances #252-91) and the conditions and requirements as set forth therein. The Board of Adjustment shall specifically consider and be able to find:
 - a. That the proposed use will not constitute a public nuisance by creating excessive noise, odor, traffic, dust, or damage to the environment or surrounding properties;
 - b. That a reasonable degree of reclamation and proper drainage control is feasible; and
 - c. That the owner and/or applicant has not had a permit revoked or bond or other security forfeited for failure to comply with any Federal, State or local laws, regulations or conditions, including land reclamation, pertaining to the proposed use.
9. Radio, telephone or television transmitting or relay facilities, including line-of-sight relays and towers, except as permitted by KRS 100.324, and only under the following conditions:
 - a. Such facilities shall be operated at all times in compliance with applicable Federal, State, and local laws and regulations, including all standards of the Federal Aviation Administration and the Federal Communications Commission.
 - b. No transmitting or relay tower shall be located closer than the height of the tower from another lot under different ownership, or any public or private street or highway, unless the tower is constructed to withstand a minimum wind speed of one hundred (100) miles per hour.
 - c. The plans of tower construction shall be certified by an engineer registered in the State of Kentucky.
 - d. All towers shall be equipped with an anti-climbing device or fence to prevent unauthorized access.
10. Kindergartens and nursery schools for four (4) and not more than twelve (12) children, only when accessory to a residential use. A fenced and screened play area shall be provided, which shall contain not less than twenty-five (25) square feet per child.
11. Family child care for seven (7) and not more than twelve (12) children, provided that the total number of children living or being cared for on the premises shall not exceed twelve (12). A fenced outdoor play area shall be provided, which shall contain not less than twenty-five (25) square feet per child.
12. Places of religious assembly.
13. Schools for academic instruction, including accessory dormitories.
14. Kindergartens, nursery schools and child care centers for four (4) or more children when accessory to a place of religious assembly or school, as permitted herein. A fenced and screened play area shall be provided, which shall contain not less than twenty-five (25) square feet per child.
15. Bed and breakfast facilities, limited to the rental of not more than five (5) rooms per property, provided that no use permitted under this section shall be located less than one (1) mile, as measured from the facility, from another use permitted under this section. The Board of Adjustment, in considering approval of such conditional use, shall consider and make a finding that the number of rooms granted shall not

have an adverse effect on surrounding properties. In addition, in considering such a conditional use, the Board of Adjustment shall take into consideration the number of bed and breakfast facilities, if any, within the general neighborhood of the property being considered for such use.

16. Any uses that are clearly incidental and subordinate to a small farm winery operation licensed as such by the Commonwealth of Kentucky, other than those specifically outlined in KRS 100, and permitted by Article 8-1(c)(2), which may include special events with or without live entertainment or a small bistro/restaurant of up to two (2) seats per 1,000 gallons of wine, brandies and cordials produced or compounded on site per year. For special events, documentation shall be provided that arrangements have been made with the LFUCG Division of Fire and Emergency Services for approval of fire suppression and control; that Fayette County Health Department approval has been obtained for the septic system and/or portable toilets; that Fayette County Health Department approval has been obtained for any food services offered, whether it be provided on site or catered for each event; and that approval be obtained from the Division of Building Inspection for any temporary structures used (i.e., tents).
17. Agritourism activities to include corn mazes; children's rides; farm gift shops (limited to 500 square feet); educational classes related to agricultural products or skills; horse shows involving more than 70 participants; and seasonal activities.
18. Ecotourism activities to include commercial hiking, bicycling trails; equine trails; zip line trails; tree canopy tours; canoeing and kayaking launch sites; botanical gardens; and nature preserves.
19. Youth camps.

8-2(e) Prohibited Uses (All uses other than those listed as principal, accessory, or conditional uses or substantially similar to principal, accessory, or conditional uses shall be prohibited. The uses below are provided for illustration purposes and for the purpose of limiting permitted uses, and are not intended to be a total listing of all the uses that are prohibited.)

1. Establishments for the processing of crude petroleum, natural gas, or oil shale.
2. Disposal of garbage and refuse, transfer stations.
3. Multi-family, two-family or townhouse dwelling units.
4. Retail sales or services, wholesale, or warehouse uses, except as provided herein.
5. Offices, museums, and institutional uses.
6. Commercial recreational facilities, such as amusement parks; bowling alleys; skating rinks; pool or billiard halls; establishments with coin-operated pool or billiard tables, or outdoor theaters.
7. Hotels, motels, boarding or lodging houses, except bed and breakfast facilities permitted herein.
8. Manufacturing, compounding, assembling, processing and packaging and other industrial uses.
9. Automobile, truck, ATV, motorcycle, bicycle moto-cross, or other vehicle or bicycle race tracks.
10. Garden centers, market gardens, commercial greenhouses and plant nurseries.
11. Major or minor automobile and truck repair.
12. Automobile service stations.
13. Storage, except as permitted herein.
14. Junk yards.
15. Sale of new or used merchandise, except as provided herein.
16. Stockyards and slaughtering of animals.
17. Penal or correctional institutions.
18. Sawmills.
19. Commercial kennels.
20. Hospitals, nursing homes, rest homes, orphanages, community residences.
21. Sewage disposal plants.
22. Fraternity and sorority houses.
23. Private clubs, including accessory restaurants and/or the serving of alcoholic beverages, except as permitted herein.
24. Horse race tracks.
25. Veterinarian offices.
26. Commercial composting.
27. Airports.
28. Concrete mixing and asphalt plants.
29. Commercial woodlots.
30. Golf courses.
31. Adult entertainment establishments or other similar adult uses.
32. Special events, parties, festivals, and concerts related to a commercial purpose.
33. Commercial farm markets.
34. Recreation vehicle and trailer campgrounds; and recreational outfitters.

Lot, Yard and Height Requirements (See Articles 3 and 15 for additional regulations.)

8-2(f) Minimum Lot Size - Ten (10) acres.

8-2(g) Minimum Lot Frontage - 250 feet.

8-2(h) Minimum Front Yard - 300' from the right-of-way line, except for the following:

- (1) Lots which have principal permitted residential structures less than 300' from the right-of-way line; then the minimum front yard shall be coincident with the existing front yard, or 50', whichever is greater;
- (2) Lots which were created by subdivision plats recorded prior to January 26, 1995 shall have the minimum front yard coincident with the platted building line, or 50', whichever is greater;
- (3) Existing lots less than 350' in lot depth shall have the minimum front yard coincident with the platted building line, or 50', whichever is greater.

8-2(i) Minimum Each Side Yard - 50 feet.

8-2(j) Minimum Rear Yard - 100 feet.

8-2(k) Minimum Useable Open Space - No limitation.

8-2(l) Maximum Lot Coverage - No limitation.

8-2(m) Maximum Height of Building - 35 feet, except for buildings devoted solely to agricultural uses, then no limitation.

8-2(n) Off-Street Parking (See Article 16 for additional parking regulations.)

Bed and Breakfast Facilities - One space per room rented other than the first room.

Places of Religious Assembly - One (1) space for each five (5) seats in the main auditorium, with a minimum of five (5) spaces.

Non-Commercial Outdoor Athletic Facilities, including Baseball Fields; Soccer Fields; Outdoor Rodeos - One (1) space for every five (5) spectator seats, or one for every three active participants in the sport, whichever is greater.

Commercial and Non-Commercial Riding Stables, Fishing Lakes, Campgrounds, Sportsmen's Farms, Zoological Gardens, and Other Recreational Facilities, Ecotourism and Agritourism activities not otherwise stated herein - Five (5) spaces, plus one (1) space for each employee for each separate use.

Dormitories - Five (5) spaces, plus one (1) space for every five (5) beds.

Dwelling Units - One (1) parking space per dwelling unit.

Equine Hospitals or Large Animal Hospitals - One (1) space per four hundred (400) square feet of floor area, with a minimum of five (5) spaces; but not including any barns.

Rehabilitation Homes - One (1) space for each three (3) beds; plus one (1) space for each employee on the maximum shift, with a minimum of five (5) spaces.

Kindergartens, Nursery Schools, Child Care Centers and Family Child Care for seven (7) or more children - Three (3) spaces for the first twelve (12) children, plus one space for every ten (10) (or fraction thereof) additional children.

Private Clubs - One (1) space for every four (4) members.

Small Farm Winery Restaurant/Bistro - One (1) space for every six (6) seats in the restaurant or bistro.

Conditional Uses - Parking requirements stated herein for conditional uses are minimum requirements; the Board of Adjustment may establish additional requirements, as needed. For any conditional use not otherwise stated herein: one (1) space per employee, with a minimum of five (5) spaces.

Combinations - Combined uses shall provide parking equal to the sum of the individual requirements.

8-2(o) Special Provisions - For any development in an Agricultural Buffer Area (A-B) zone, the following provisions shall apply:

1. All Agricultural-Buffer Area (A-B) zone developments shall provide a fenced buffer yard along the boundary of the development with land recommended for Natural

Areas and Core Agricultural and Rural Land in the Comprehensive Plan. In order to prevent the growth of plants that may be toxic to animals, the buffer yard shall be kept mowed and free of trees, shrubs and plants other than grasses. Existing vegetation may remain as specified under Article 6-3(b) of the Land Subdivision Regulations. Buffer yards may, however, be used for utility installation and easements. Such buffer yard shall be the responsibility of the property owner in the A-B zone to install and to maintain, and shall consist of the following:

- a. A double row of standard gauge diamond-mesh wire fences, of durable construction, at least eight (8) feet apart, with one fence to be not less than fifty-two (52) inches high, set on 7½-foot posts, with a required 6-inch top board, to be placed closest to the A-B development; and the second fence to be not less than fifty-eight (58) inches high, set on 8-foot posts, with a required 6-inch top board, placed nearest the adjoining agricultural property; or
- b. A single, standard gauge, diamond mesh wire fence, of durable construction, not less than seventy-two (72) inches high, set on 9-foot posts, with a required 6-inch top board, with the mowed buffer yard to be eight (8) feet adjoining the fence; or
- c. Other buffer yard and fencing which achieves the intent of this section and which is agreed upon by the developer of the Agricultural Buffer Area and the adjoining agricultural property.

8-3 AGRICULTURAL NATURAL AREAS (A-N) ZONE

8-3(a) Intent - This zone is established to preserve areas within the Rural Service Area that are physically unique, primarily due to their association with the Kentucky River and its tributaries. This area is characterized by steeper slopes, forested areas, and thinner/poorer soils, and is known as a habitat for rare and unusual flora and fauna. Because these lands are environmentally sensitive, special care is needed to ensure that the uses that are permitted are compatible with the goal of conservation and preservation of these lands. The Land Use Element of the Comprehensive Plan shall be used to determine the appropriate locations for the Agricultural Natural Areas (A-N) Zone.

8-3(b) Principal Uses (Other uses substantially similar to those listed herein shall also be deemed permitted.)

1. Land used solely for agricultural purposes, including small farm wineries and equine-related activities, as outlined in KRS 100.
2. Single family detached dwellings.

8-3(c) Accessory Uses (Uses and structures which are customarily accessory, clearly incidental and subordinate to permitted uses.)

1. Accessory uses in connection with agriculture, farming, dairying, stock raising or similar uses, such as agricultural structures; stables; farm tours; hayrides; petting zoos; and parking areas, provided all yard requirements for a principal residence are met.
2. Those specific agricultural uses outlined in KRS 100 that are incidental only to a small farm winery licensed as such by the Commonwealth of Kentucky, such as the manufacture and bottling of wines; tasting rooms for the purpose of serving complimentary samples; sale by the drink or bottle, either on or off premises; and sale and shipment of wine, either wholesale or retail.
3. Home offices and home occupations.
4. Temporary roadside stands offering for sale only agricultural products grown on the premises; or value-added product sales primarily from agricultural resources grown or raised on the premises.
5. Keeping of not more than two (2) roomers or boarders by a resident family.
6. Non-commercial recreational facilities, such as baseball fields; soccer fields; polo fields; swimming pools; tennis courts; bicycling or hiking trails and the like.
7. Private garages, storage sheds, parking lots, and private farm vehicle fueling facilities.
8. Living quarters, without kitchen facilities and not used for rental purposes, for guests and employees of the premises.
9. Satellite dish antennas, as regulated in Article 15-8.
10. Family child care for up to six (6) children, provided that the total number of children living or being cared for on the premises shall not exceed six (6).
11. Mobile homes, as provided in Article 10.
12. Tenant homes, provided all yard requirements for a principal residence are met.

8-3(d) Conditional Uses (Permitted only with Board of Adjustment approval.) For any of the following conditional uses established after January 26, 1995, a total of 10,000 square feet shall be the maximum allowable for all structures proposed for such uses. Prior to the approval of any conditional use containing environmentally sensitive land, such as flood hazard areas; areas of significant tree stands; sinkhole and karst areas;

slopes exceeding 15%; "special natural protection" areas, as designated in the Comprehensive Plan; and stone fences, the applicant must prove, and the Board of Adjustment must find, that adequate safeguards will be in place to ensure the least negative impact on the land. This proof and finding shall extend to uses accessory to permitted conditional uses.

In making its determination, the Board of Adjustment shall:

- require the submission of an environmental assessment prepared by a qualified professional.
 - consider mitigation of environmental impacts over time.
 - consider the operational plan of any proposed agritourism or ecotourism activities.
 - consider requiring certification for any proposed ecotourism activities.
1. Cemeteries, crematories, columbariums, mausoleums, including animal burial grounds.
 2. Places of religious assembly.
 3. Non-service facilities of public utilities and common carriers by rail, including office, garage, and warehouse space when not incidental to a service facility as provided in KRS 100.324.
 4. Commercial and non-commercial outdoor recreational facilities (without outdoor lighting, loud speakers, retail sales of merchandise, restaurants or food service, and the like), including zoological gardens; sportsmen's farms (including outdoor rifle and other firearm ranges); native animal game preserves; outdoor rodeos; hunting and trapping; primitive campgrounds; and fishing lakes, including private clubs for only these uses.
 5. Mining and/or quarrying of non-metallic minerals, but only when the proposal complies with the requirements of the Mining/Quarrying Ordinance (Code of Ordinances #252-91) and the conditions and requirements as set forth therein. The Board of Adjustment shall specifically consider and be able to find:
 - a. That the proposed use will not constitute a public nuisance by creating excessive noise, odor, traffic, dust, or damage to the environment or surrounding properties;
 - b. That a reasonable degree of reclamation and proper drainage control is feasible; and
 - c. That the owner and/or applicant has not had a permit revoked or bond or other security forfeited for failure to comply with any Federal, State or local laws, regulations or conditions, including land reclamation, pertaining to the proposed use.
 6. Radio, telephone or television transmitting or relay facilities, including line-of-sight relays and towers, except as permitted by KRS 100.324, and only under the following conditions:
 - a. Such facilities shall be operated at all times in compliance with applicable Federal, State, and local laws and regulations, including all standards of the Federal Aviation Administration and the Federal Communications Commission.
 - b. No transmitting or relay tower shall be located closer than the height of the tower from another lot under different ownership, or any public or private street or highway, unless the tower is constructed to withstand a minimum wind speed of one hundred (100) miles per hour.
 - c. The plans of tower construction shall be certified by an engineer registered in the State of Kentucky.
 - d. All towers shall be equipped with an anti-climbing device or fence to prevent unauthorized access.
 7. Bed and breakfast facilities, limited to the rental of not more than five (5) rooms per property, provided that no use permitted under this section shall be located less than one (1) mile, as measured from the facility, from another use permitted under this section. The Board of Adjustment, in considering approval of such conditional use, shall consider and make a finding that the number of rooms granted shall not have an adverse effect on surrounding properties. In addition, in considering such a conditional use, the Board of Adjustment shall take into consideration the number of bed and breakfast facilities, if any, within the general neighborhood of the property being considered for such use.
 8. Any uses that are clearly incidental and subordinate to a small farm winery operation licensed as such by the Commonwealth of Kentucky, other than those specifically outlined in KRS 100, and permitted by Article 8-1(c)(2), which may include special events with or without live entertainment or a small bistro/restaurant of up to two (2) seats per 1,000 gallons of wine, brandies and cordials produced or compounded on site per year. For special events, documentation shall be provided that arrangements have been made with the LFUCG Division of Fire and Emergency Services for approval for fire suppression and control; that Fayette County Health Department approval has been obtained for the septic system and/or portable toilets; that Fayette County Health Department approval has been obtained for any food services offered, whether it be provided on site or catered for each event; and that approval be obtained from the Division of Building Inspection for any temporary structures used (i.e., tents).

9. Agritourism activities, to include corn mazes; farm gift shops (limited to 500 square feet); educational classes related to agricultural products and skills; horse shows involving more than 70 participants; and seasonal activities.
10. Ecotourism activities, to include commercial hiking and bicycling trails; equine trails; tree canopy tours; canoeing and kayaking launch sites; botanical gardens; nature preserves and recreational outfitters, limited to equipment rental only.
11. Youth camps.
12. Home-based businesses.

8-3(e) Prohibited Uses (All uses other than those listed as principal, accessory, or conditional uses or substantially similar to principal, accessory, or conditional uses shall be prohibited. The uses below are provided for illustration purposes and for the purpose of limiting permitted uses, and are not intended to be a total listing of all the uses that are prohibited.)

1. Establishments for the processing of crude petroleum, natural gas, or oil shale.
2. Disposal of garbage and refuse, transfer stations.
3. Multi-family, two-family or townhouse dwelling units.
4. Retail sales or services, wholesale, or warehouse uses, except as provided herein.
5. Offices, museums, and institutional uses.
6. Commercial recreational facilities, such as amusement parks; bowling alleys; skating rinks; pool or billiard halls; establishments with coin-operated pool or billiard tables, or outdoor theaters.
7. Hotels, motels, boarding or lodging houses, except bed and breakfast facilities permitted herein.
8. Manufacturing, compounding, assembling, processing and packaging, and other industrial uses.
9. Automobile, truck, ATV, motorcycle, bicycle moto-cross, or other vehicle or bicycle race tracks.
10. Garden centers, market gardens, commercial greenhouses and plant nurseries.
11. Major or minor automobile and truck repair.
12. Automobile service stations.
13. Storage, except as permitted herein.
14. Junk yards.
15. Sale of new or used merchandise, except as provided herein.
16. Stockyards and slaughtering of animals.
17. Penal or correctional institutions.
18. Sawmills.
19. Commercial kennels.
20. Hospitals, nursing homes, rest homes, orphan-ages, community residences.
21. Sewage disposal plants.
22. Fraternity and sorority houses.
23. Private clubs, including accessory restaurants and/or the serving of alcoholic beverages, except as permitted herein.
24. Horse race tracks.
25. Veterinarian offices, including equine and large animal hospitals.
26. Commercial composting.
27. Airports.
28. Concrete mixing and asphalt plants.
29. Commercial woodlots.
30. Golf courses.
31. Adult entertainment establishments or other similar adult uses.
32. Special events, parties, festivals, concerts, and children's rides related to a commercial purpose.
33. Commercial farm markets.
34. Zip line trials.
35. Recreation vehicle and trailer campgrounds.

Lot, Yard and Height Requirements (See Articles 3 and 15 for additional regulations.)

8-3(f) Minimum Lot Size - Forty (40) acres.

8-3(g) Minimum Lot Frontage - 750'.

8-3(h) Minimum Front Yard - 300' from the right-of-way line, except for the following:

- (1) Lots which have principal permitted residential structures less than 300' from the right-of-way line; then the minimum front yard shall be coincident with the existing front yard, or 50', whichever is greater;
- (2) Lots which were created by subdivision plats recorded prior to January 26, 1995 shall have the minimum front yard coincident with the platted building line, or 50', whichever is greater;
- (3) Existing lots less than 350' in lot depth shall have the minimum front yard coincident with the platted building line, or 50', whichever is greater.

8-3(i) Minimum Each Side Yard - 50'.

8-3(j) Minimum Rear Yard - 100'.

8-3(k) Minimum Useable Open Space - No limitation.

8-3(l) Maximum Lot Coverage - No limitation.

8-3(m) Maximum Height of Building - 35', except for buildings devoted solely to agricultural uses, then no limitation.

8-3(n) Off-Street Parking (See Article 16 for additional parking regulations.)

Bed and Breakfast Facilities - One space per room rented other than the first room.

Places of Religious Assembly - One (1) space for each five (5) seats in the main auditorium, with a minimum of five (5) spaces.

Non-Commercial Outdoor Athletic Facilities, including Baseball Fields; Soccer Fields; Outdoor Rodeos - One (1) space for every five (5) spectator seats, or one for every three active participants in the sport, whichever is greater.

Commercial and Non-Commercial Riding Stables, Fishing Lakes, Campgrounds, Sportsmen's Farms, Zoological Gardens, and Other Recreational Facilities, Ecotourism and Agritourism activities not otherwise stated herein - Five (5) spaces, plus one (1) space for each employee for each separate use.

Dwelling Units - One (1) parking space per dwelling unit.

Kindergartens, Nursery Schools, Child Care Centers and Family Child Care for seven (7) or more children - Three (3) spaces for the first twelve (12) children, plus one space for every ten (10) (or fraction thereof) additional children.

Private Clubs - One (1) space for every four (4) members.

Small Farm Winery Restaurant/Bistro - One (1) space for every six (6) seats in the restaurant or bistro.

Conditional Uses - Parking requirements stated herein for conditional uses are minimum requirements; the Board of Adjustment may establish additional requirements as needed. For any conditional use not otherwise stated herein: one (1) space per employee with a minimum of five (5) spaces.

Combinations - Combined uses shall provide parking equal to the sum of the individual requirements.

8-4 AGRICULTURAL URBAN (A-U) ZONE

8-4(a) Intent - This zone is intended to control the development of rural land within the Urban Service Area over a period of time so as to manage the growth of the community. In order to avoid premature or improper development, land should remain in this zone until public facilities and services are or will be adequate to serve urban uses.

8-4(b) Principal Uses (Other uses substantially similar to those listed herein shall also be deemed permitted.)

1. The principal permitted uses in the A-R zone.
2. Farm tours and hayrides.

8-4(c) Accessory Uses (Uses and structures which are customarily accessory, clearly incidental and subordinate to permitted uses.)

1. The permitted accessory uses in the A-R zone.

8-4(d) Conditional Uses (Permitted only with Board of Adjustment approval.)

1. Items 1-5, 8, 10-12 (but excluding outdoor rifle and other firearm ranges), and 18-22 of the permitted conditional uses in the A-R zone, provided the square footage limitations shall not apply unless required by the Board of Adjustment.
2. Cemeteries, crematories, columbariums, and mausoleums for human burial; but only when adjacent to, or extensions of, existing cemeteries.
3. Garden centers, only when operated in conjunction with a commercial greenhouse or plant nursery on the same premises, and only when all conditions required of commercial greenhouses in Section 8-1(d)(5) above are met.

4. Offices of veterinarians, and animal hospitals and clinics.
5. Radio or television studios, offices and associated equipment used in conjunction with an existing transmitting or relay tower, provided that such studios, offices and associated equipment are entirely enclosed within a building any part of which is located within five hundred (500) feet of such existing tower.
6. Funeral homes.
7. Mining of non-metallic minerals, but only when the proposal complies with the requirements of the Mining/Quarrying Ordinance (Code of Ordinances #252-91) and the conditions and requirements as set forth therein. The Board of Adjustment shall specifically consider and be able to find:
 - a. That the proposed use will not constitute a public nuisance by creating excessive noise, odor, traffic, dust, or damage to the environment or surrounding properties;
 - b. That a reasonable degree of reclamation and proper drainage control is feasible; and
 - c. That the owner and/or applicant has not had a permit revoked or bond or other security forfeited for failure to comply with any Federal, State or local laws, regulations or conditions, including land reclamation, pertaining to the proposed use.
8. Commercial and non-commercial outdoor recreational facilities, including golf courses; golf driving ranges; and outdoor athletic facilities, such as baseball fields; soccer fields; or polo fields.
9. Sewage disposal plants.
10. Private clubs, including accessory restaurants and/or the serving of alcoholic beverages.
11. Hospitals, nursing homes, rest homes, assisted living facilities, orphanages, community residences.
12. Schools for academic instruction, including dormitories, fraternity and sorority houses.
13. Any uses that are clearly incidental and subordinate to a small farm winery operation licensed as such by the Commonwealth of Kentucky, other than those specifically outlined in KRS 100, and permitted by Article 8-1(c)(2), which may include special events with or without live entertainment or a small bistro/restaurant of up to two (2) seats per 1,000 gallons of wine, brandies and cordials produced or compounded on site per year. For special events, documentation shall be provided that arrangements have been made with the LFUCG Division of Fire and Emergency Services for approval for fire suppression and control; that Fayette County Health Department approval has been obtained for the septic system and/or portable toilets; that Fayette County Health Department approval has been obtained for any food services offered, whether it be provided on site or catered for each event; and that approval be obtained from the Division of Building Inspection for any temporary structures used (i.e., tents).
14. Agritourism activities, to include corn mazes; special events, parties and festivals; concerts; children's rides; farm gift shops (limited to 500 square feet); educational classes related to agricultural products or skills; horse shows involving more than 70 participants; and seasonal activities.
15. Ecotourism activities, to include commercial hiking, bicycling trails; equine trails; zip line trails; tree canopy tours; canoeing and kayaking launch sites; primitive and vehicular or trailer campgrounds; fishing and hunting clubs; botanical gardens; nature preserves; and recreational outfitters.
16. Youth camps.

8-4(e) Prohibited Uses (All uses, other than those listed as principal, accessory, or conditional uses or substantially similar to principal, accessory, or conditional uses, shall be prohibited. The uses below are provided for illustration purposes and for the purpose of limiting permitted uses, and are not intended to be a total listing of all the uses that are prohibited.)

1. The prohibited uses in the A-R zone, except as permitted herein.
2. Extraction of crude petroleum or natural gas.
3. Quarrying of non-metallic minerals.
4. Airports.
5. Radio, telephone or television transmitting towers, antennas and line-of-sight relays, except as permitted herein.
6. Penal or correctional institutions.
7. Outdoor rifle and other firearm ranges.
8. Concrete mixing.
9. Asphalt plants.
10. Adult entertainment establishments or other similar adult uses.
11. Museums.
12. Commercial farm markets.

Lot, Yard, and Height Requirements (See Articles 3 and 15 for additional regulations.)

8-4(f) Minimum Lot Size - No limitation, except for single family detached residences as a principal permitted use; commercial greenhouses, garden centers and equine hospitals as conditional uses, then ten (10) acres minimum.

8-4(g) Minimum Lot Frontage - 250'.

8-4(h) Minimum Front Yard - 50' from the right-of-way.

8-4(i) Minimum Each Side Yard - 25'.

8-4(j) Minimum Rear Yard - 25'.

8-4(k) Minimum Useable Open Space - No limitation.

8-4(l) Maximum Lot Coverage - No limitation.

8-4(m) Maximum Height of Building - No limitation.

8-4(n) Off-Street Parking (See Article 16 for additional parking regulations.)

As for A-R.

Commercial and Non-Commercial Outdoor Athletic Facilities, including Baseball Fields; Soccer Fields; or Polo Fields - One (1) space for every five (5) spectator seats, or one for every three active participants in the sport, whichever is greater.

Dormitories, Sorority and Fraternity Houses - Five (5) spaces, plus one (1) space for every five (5) beds.

Golf Courses - Three (3) spaces for every hole on the main course.

Golf Driving Range - One (1) space per driving tee, plus one (1) space per employee, with a minimum of five (5) spaces.

Hospitals, Nursing and Rest Homes, Orphanages, and Rehabilitation Homes - One (1) space for each three (3) beds; plus one (1) space for each employee on the maximum shift, with minimum of five (5) spaces.

Offices of Veterinarians and Animal Hospitals and Clinics - One (1) space per two hundred (200) square feet of floor area (not including any barns, or other indoor areas devoted principally to housing animals), with a minimum of five (5) spaces.

Private Clubs - One (1) space for every four (4) members.

Assisted Living Facilities - Three (3) spaces for each four (4) bedrooms, plus one (1) space for each employee on the maximum shift.

Small Winery Restaurant/Bistro - One (1) space for every six (6) seats in the restaurant or bistro.

Combinations - Combined uses shall provide parking equal to the sum of the individual requirements.

8-5 SINGLE FAMILY RESIDENTIAL (R-1A) ZONE

8-5(a) Intent - These zones are established to provide for single family detached residences and supporting uses. The zones should be located in areas of the community where services and facilities will be adequate to serve the anticipated population. The Comprehensive Plan should be used to determine the location and density (units/acre) of each single family zone.

8-5(b) Principal Uses (Other uses substantially similar to those listed herein shall also be deemed permitted.)

1. Single family detached residences.
2. Parks and playgrounds operated by government.
3. Temporary real estate sales offices for the sale of lots, located only within the subdivision in which said lots are located; to be removed at the end of two years or when all the lots are sold, whichever comes first.

8-5(c) Accessory Uses (Uses and structures which are customarily accessory, clearly incidental and subordinate to permitted uses.)

1. Private garages, storage sheds, and parking areas.

2. Living quarters, without cooking facilities and not rented, for guests and employees of the premises.
3. Swimming pools and tennis courts, including accessory structures and temporary structures associated with those uses.
4. Agricultural uses, excluding commercial stock raising.
5. Private, non-commercial parks and open space.
6. Home offices and home occupations.
7. A ground, roof or pole-mounted satellite dish antenna, as regulated by Article 15-8.
8. Family child care for up to six (6) children, provided that the total number of children living or being cared for on the premises shall not exceed six (6).
9. Hiking and bicycling trails.

8-5(d) Conditional Uses (Permitted only with Board of Adjustment approval.)

1. Kindergartens and nursery schools for four (4) and not more than twelve (12) children, when accessory to and located in the same structure with the single family residence occupied by the owner or operator. All kindergartens and nursery schools shall provide a fenced and screened play area, which shall contain not less than twenty-five (25) square feet per child.
2. Kindergartens, nursery schools and child care centers for four (4) or more children, when accessory to a place of religious assembly, school or private club as permitted herein. A fenced and screened play area shall be provided, which shall contain not less than twenty-five (25) square feet per child.
3. Home-based businesses.
4. Cemeteries, columbariums, and mausoleums.
5. Outdoor commercial and non-commercial recreational facilities, such as golf courses; sportsmen's farms; riding stables and equine trails; fishing lakes and non-commercial swimming pool; tennis courts; campgrounds; and private clubs.
6. Places of religious assembly.
7. Schools for academic instruction.
9. Mining of non-metallic minerals, but only when the proposal complies with the requirements of the Mining/Quarrying Ordinance (Code of Ordinances #252-91) and the conditions and requirements as set forth therein. The Board of Adjustment shall specifically consider and be able to find:
 - a. That the proposed use will not constitute a public nuisance by creating excessive noise, odor, traffic, dust, or damage to the environment or surrounding properties;
 - b. That a reasonable degree of reclamation and proper drainage control is feasible; and
 - c. That the owner and/or applicant has not had a permit revoked or bond or other security forfeited for failure to comply with any Federal, State or local laws, regulations or conditions, including land reclamation, pertaining to the proposed use.
10. Family child care for seven (7) and not more than twelve (12) children, provided that the total number of children living or being cared for on the premises shall not exceed twelve (12). A fenced outdoor play area shall be provided, which shall contain not less than twenty-five (25) square feet per child.
11. Bed and breakfast facilities, limited to the rental of not more than one (1) room. The Board of Adjustment, in considering approval of such conditional use, shall consider and make a finding that the number of rooms granted shall not have an adverse effect on surrounding properties. In addition, in considering such a conditional use, the Board of Adjustment shall take into consideration the number of bed and breakfast facilities, if any, within the general neighborhood of the property being considered for such use.
12. Historic house museums.
13. Seasonal activities.
14. Market gardens.

8-5(e) Prohibited Uses (All uses, other than those listed as principal, accessory, or conditional uses or substantially similar to principal, accessory, or conditional uses, shall be prohibited. The uses below are provided for illustration purposes and for the purpose of limiting permitted uses, and are not intended to be a total listing of all the uses that are prohibited.)

1. Those uses prohibited in the A-U zone, except as permitted herein.
2. Commercial kennels, equine hospitals, and offices of veterinarians.
3. Any use dependent upon septic tanks or pit privies.
4. The above- or below- ground storage of any flammable material in gaseous form, including compressed natural gas, and the above- or below- ground storage of more than five (5) gallons of gasoline.
5. Ecotourism activities, except as permitted herein.
6. Zoological gardens.

Lot, Yard, and Height Requirements (See Articles 3 and 15 for additional regulations.)

8-5(f) Minimum Lot Size - One acre; or 25,000 square feet for property rezoned to R-1A after July 14, 1994.

8-5(g) Minimum Lot Frontage - 150'; or 125' for property rezoned to R-1A after July 14, 1994.

8-5(h) Minimum Front Yard - 50'; or 40' for property rezoned to R-1A after July 14, 1994.

8-5(i) Minimum Each Side Yard - 25'; or 10' for property rezoned to R-1A after July 14, 1994.

8-5(j) Minimum Rear Yard - 25'.

8-5(k) Minimum Useable Open Space - No limitation.

8-5(l) Maximum Lot Coverage - No limitation.

8-5(m) Maximum Height of Building - 35'.

8-5(n) Off-Street Parking (See Article 16 for additional parking regulations.)

Places of Religious Assembly - One (1) space for each five (5) seats in the main auditorium, with a minimum of five (5) spaces.

Dwelling Units - One (1) space per dwelling unit.

Elementary and Junior High Schools - One (1) space for every fifteen (15) seats in the main auditorium; or one (1) space for every classroom, plus one (1) space for each employee, whichever is greater.

All Other Schools for Academic Instruction - One (1) space for every five (5) seats in the main auditorium; or one (1) space for every five (5) classroom seats, whichever is greater.

Golf Courses - Three (3) spaces for every hole on the main course.

Keeping of Roomers or Boarders - One (1) space for every two (2) roomers or boarders.

Kindergartens, Nursery Schools, Day Nurseries and Child Care Centers - Three (3) spaces for the first twelve (12) children, plus one (1) space for every ten (10) (or fraction thereof) additional children.

Family Child Care for between seven (7) and twelve (12) children - One (1) space in addition to that required for the dwelling.

Private Clubs - One (1) space for every four (4) members.

Non-Commercial Outdoor Recreational Facilities, including Playgrounds; Sportsmen's Farms; and Riding Stables - One (1) space for every four (4) members, with a minimum of five spaces.

Temporary Real Estate Sales Offices - One (1) space for every four hundred (400) square feet of floor area to be used as the sales office.

Conditional Uses - Parking requirements stated herein for conditional uses are minimum requirements; the Board of Adjustment may establish additional requirements, as needed. Where no requirement is stated herein, the Board shall determine the required parking for the conditional use.

Combinations - Combined uses shall provide parking equal to the sum of individual requirements.

8-6 SINGLE FAMILY RESIDENTIAL (R-1B) ZONE

8-6(a) Intent - As for R-1A.

8-6(b) Principal Uses (Other uses substantially similar to those listed herein shall also be deemed permitted.)

1. The principal permitted uses in the R-1A zone.

8-6(c) Accessory Uses (Uses and structures which are customarily accessory, clearly incidental and subordinate to permitted uses.)

1. The permitted accessory uses in the R-1A zone.

8-6(d) Conditional Uses (Permitted only with Board of Adjustment approval.)

1. The permitted conditional uses in the R-1A zone.

8-6(e) Prohibited Uses (All uses other than those listed as principal, accessory, or conditional uses or substantially similar to principal, accessory, or conditional uses shall be prohibited. The uses below are provided for illustration purposes and for the purpose of limiting permitted uses, and are not intended to be a total listing of all the uses that are prohibited.)

1. The uses prohibited in the R-1A zone.

Lot, Yard, and Height Requirements (See Articles 3 and 15 for additional regulations.)

8-6(f) Minimum Lot Size - 15,000 square feet.

8-6(g) Minimum Lot Frontage - 100'.

8-6(h) Minimum Front Yard - 40'.

8-6(i) Minimum Each Side Yard - 10'.

8-6(j) Minimum Rear Yard - 10'.

8-6(k) Minimum Useable Open Space - No limitation.

8-6(l) Maximum Lot Coverage - No limitation.

8-6(m) Maximum Height of Building - 35'.

8-6(n) Off-Street Parking (See Article 16 for additional parking regulations.)

As for R-1A.

8-7 SINGLE FAMILY RESIDENTIAL (R-1C) ZONE

8-7(a) Intent - As for R-1A.

8-7(b) Principal Uses (Other uses substantially similar to those listed herein shall also be deemed permitted.)

1. The principal permitted uses in the R-1A zone.

8-7(c) Accessory Uses (Uses and structures which are customarily accessory, clearly incidental and subordinate to permitted uses.)

1. The permitted accessory uses in the R-1A zone.

8-7(d) Conditional Uses (Permitted only with Board of Adjustment approval.)

1. The permitted conditional uses in the R-1A zone.

8-7(e) Prohibited Uses (All uses other than those listed as principal, accessory, or conditional uses or substantially similar to principal, accessory, or conditional uses shall be prohibited. The uses below are provided for illustration purposes and for the purpose of limiting permitted uses, and are not intended to be a total listing of all the uses that are prohibited.)

1. The prohibited uses in the R-1A zone.

Lot, Yard and Height Requirements (See Articles 3, 8-7(o) below, and 15 for additional regulations.)

8-7(f) Minimum Lot Size - 8,000 square feet.

8-7(g) Minimum Lot Frontage - 60'.

8-7(h) Minimum Front Yard - 30'.

8-7(i) Minimum Each Side Yard - 8'.

8-7(j) Minimum Rear Yard - 10'.

8-7(k) Minimum Useable Open Space - No limitation.

8-7(l) Maximum Lot Coverage - No limitation.

8-7(m) Maximum Height of Building - 35'.

8-7(n) Off-Street Parking (See Article 16 for additional parking regulations.)

As for R-1A.

8-7(o) Special Provisions

1. Lot frontage, yard and height requirements for single family detached dwellings in defined Infill and Redevelopment areas are for existing lots as of December 5, 2002, and shall be as follows:
 - a. Where existing lot frontage is 24 feet but less than 35 feet, the provisions of Article 15-7 and the following shall apply:
 1. Minimum lot frontage - 24 feet.
 2. Minimum front yard - As per Article 8-7(h), unless the average depth of the existing front yards on each of the adjacent lots on either side of the lot are less; then the minimum shall be no less than this average, or eight (8) feet, whichever is greater.
 3. Maximum front yard - 50 feet, unless the average depth of the existing front yards on each side of the adjacent lots on either side of the lot are greater; then the maximum shall be no greater than this average.
 4. Minimum side yard - 3 feet. No wall, air-conditioning unit, structure or other obstruction shall be located within the required side yard. Any fence located in a required side yard must be entirely to the rear of the principal structure on the lot.
 5. Minimum rear yard - 20% of the lot depth.
 6. Minimum usable open space - No limitation.
 7. Minimum lot coverage - No limitation.
 8. Maximum height of building - 28 feet and 2½ stories.
 9. Maximum lot coverage - No limitation.
 10. Maximum floor area ratio - 0.35, or that which allows 2,600 square feet, whichever is greater.
 - b. Where existing lot frontage is 35 feet but less than 50 feet, the provisions of Article 15-7 and the following shall apply:
 1. Minimum lot frontage - 35 feet.
 2. Minimum front yard - As per Article 8-7(h), unless the average depth of the existing front yards on each of the adjacent lots on either side of the lot are less; then the minimum shall be no less than this average, or eight (8) feet, whichever is greater.
 3. Maximum front yard - 50 feet, unless the average depth of the existing front yards on each of the adjacent lots on either side of the lot are greater; then the maximum shall be no greater than this average.
 4. Minimum side yard - 5 feet.
 5. Minimum rear yard - 20% of the lot depth.
 6. Minimum usable open space - No limitation.
 7. Minimum lot coverage - No limitation.
 8. Maximum height of building - 28 feet and 2½ stories.
 9. Maximum lot coverage - No limitation.
 10. Maximum floor area ratio - 0.35, or that which allows 2,600 square feet, whichever is greater.
 - c. Where existing lot frontage is 50 feet or greater, the provisions of Article 15-7 and the following shall apply:
 1. Minimum lot frontage - 50 feet.
 2. Minimum front yard - As per Article 8-7(h), unless the average depth of the existing front yards on each of the adjacent lots on either side of the lot are less, then the minimum shall be no less than this average, or eight (8) feet, whichever is greater.
 3. Maximum front yard - 50 feet, unless the average depth of the existing front yards on each of the adjacent lots on either side of the lot are greater; then the maximum shall be no greater than this average.
 4. Minimum side yard - As per Article 8-7(i).
 5. Minimum rear yard - 20% of the lot depth.
 6. Minimum usable open space - No limitation.
 7. Minimum lot coverage - No limitation.
 8. Maximum height of building - As per Article 8-7(m).

9. Maximum lot coverage - No limitation.
10. Maximum floor area ratio - 0.7.

8-8 SINGLE FAMILY RESIDENTIAL (R-1D) ZONE

8-8(a) Intent - As for R-1A.

8-8(b) Principal Uses (Other uses substantially similar to those listed herein shall also be deemed permitted.)

1. The principal permitted uses in the R-1A zone.
2. Existing two-family dwellings that were granted principal use status in the 1969 Zoning Ordinance. No building permits shall be issued for new two-family dwellings subsequent to the date of adoption of this Zoning Ordinance.

8-8(c) Accessory Uses (Other uses substantially similar to those listed herein shall also be deemed permitted.)

1. The permitted accessory uses in the R-1A zone.

8-8(d) Conditional Uses (Permitted only with Board of Adjustment approval.)

1. The permitted conditional uses in the R-1A zone.

8-8(e) Prohibited Uses - (All uses other than those listed as principal, accessory, or conditional uses or substantially similar to principal, accessory, or conditional uses shall be prohibited. The uses below are provided for illustration purposes and for the purpose of limiting permitted uses, and are not intended to be a total listing of all the uses that are prohibited.)

1. The prohibited uses in the R-1A zone.

Lot, Yard, and Height Requirements (See Articles 3, 8-8(o) below, and 15 for additional regulations.)

8-8(f) Minimum Lot Size - 6,000 square feet.

8-8(g) Minimum Lot Frontage - 60'.

8-8(h) Minimum Front Yard - 30'.

8-8(i) Minimum Each Side Yard - 6'.

8-8(j) Minimum Rear Yard - 10'.

8-8(k) Minimum Useable Open Space - No limitation.

8-8(l) Maximum Lot Coverage - No limitation.

8-8(m) Maximum Height of Building - 35'.

8-8(n) Off-Street Parking (See Article 16 for additional parking regulations.)

As for R-1A.

8-8(o) Special Provisions

1. Lot, yard and height requirements for single family detached dwellings in defined Infill and Redevelopment areas are for existing lots as of December 5, 2002, and shall be as follows:
 - a. Where existing lot frontage is 24 feet but less than 35 feet, the provisions of Article 15-7 and the following shall apply:
 1. Minimum lot frontage - 24 feet.
 2. Minimum front yard - As per Article 8-8(h), unless the average depth of the existing front yards on each of the adjacent lots on either side of the lot are less; then the minimum shall be no less than this average, or eight (8) feet, whichever is greater.
 3. Maximum front yard - 50 feet, unless the average depth of the existing front yards on each of the adjacent lots on either side of the lot are greater; then the maximum shall be no greater than this average.
 4. Minimum side yard - 3 feet. No wall, air-conditioning unit, structure or other obstruction shall be located within the required side yard. Any fence located in a required side yard must be entirely to the rear of the principal structure on the lot.
 5. Minimum rear yard - 20% of the lot depth.

6. Minimum usable open space - No limitation.
 7. Minimum lot coverage - No limitation.
 8. Maximum height of building - 28 feet and 2½ stories.
 9. Maximum lot coverage - No limitation.
 10. Maximum floor area ratio - 0.35, or that which allows 2,600 square feet, whichever is greater.
- b. Where existing lot frontage is 35 feet but less than 50 feet, the provisions of Article 15-7 and the following shall apply:
1. Minimum lot frontage - 35 feet.
 2. Minimum front yard - As per Article 8-8(h), unless the average depth of the existing front yards on each of the adjacent lots on either side of the lot are less; then the minimum shall be no less than this average, or eight (8) feet, whichever is greater.
 3. Maximum front yard - 50 feet, unless the average depth of the existing front yards on each of the adjacent lots on either side of the lot are greater; then the maximum shall be no greater than this average.
 4. Minimum side yard - 5 feet.
 5. Minimum rear yard - 20% of the lot depth.
 6. Minimum usable open space - No limitation.
 7. Minimum lot coverage - No limitation.
 8. Maximum height of building - 28 feet and 2½ stories.
 9. Maximum lot coverage - No limitation.
 10. Maximum floor area ratio - 0.35, or that which allows 2,600 square feet, whichever is greater.
- c. Where existing lot frontage is 50 feet or greater, the provisions of Article 15-7 and the following shall apply:
1. Minimum lot frontage - 50 feet.
 2. Minimum front yard - As per Article 8-8(h), unless the average depth of the existing front yards on each of the adjacent lots on either side of the lot are less; then the minimum shall be no less than this average, or eight (8) feet, whichever is greater.
 3. Maximum front yard - 50 feet, unless the average depth of the existing front yards on each of the adjacent lots on either side of the lot are greater; then the maximum shall be no greater than this average.
 4. Minimum side yard - As per Article 8-8(i).
 5. Minimum rear yard - 20% of the lot depth.
 6. Minimum usable open space - No limitation.
 7. Minimum lot coverage - No limitation.
 8. Maximum height of building - As per Article 8-8(m).
 9. Maximum lot coverage - No limitation.
 10. Maximum floor area ratio - 0.7.

8-9 SINGLE FAMILY RESIDENTIAL (R-1E) ZONE

8-9(a) Intent - This zone is intended to provide for single family detached residences on small lots, and at a higher density than would be possible in other detached single family zones. It may be used for zero-lot-line houses and for patio houses. This zone should be at locations and at the density (units/acre) recommended by the Comprehensive Plan and in areas of the community where necessary services and facilities will be adequate to serve the anticipated population.

8-9(b) Principal Uses (Other uses substantially similar to those listed herein shall also be deemed permitted.)

1. Single family detached residences.
2. Parks and playgrounds operated by government.
3. Temporary real estate sales offices for the sale of lots, located only within the subdivision in which said lots are located; to be removed at the end of two years or when all the lots are sold, whichever comes first.

8-9(c) Accessory Uses (Uses and structures which are customarily accessory, clearly incidental and subordinate to permitted uses.)

1. Private garages, storage sheds and parking areas.
2. Swimming pools and tennis courts.
3. Agricultural uses, excluding commercial stock raising.
4. Private, non-commercial parks and open space.
5. Home offices and home occupations.
6. A ground, roof or pole-mounted satellite dish antenna, as regulated by Article 15-8.
7. Family child care for up to six (6) children, provided that the total number of children living or being cared for on the premises shall not exceed six (6).
8. Hiking and bicycling trails.

8-9(d) Conditional Uses (Permitted only with Board of Adjustment approval.)

1. As for R-1A.

8-9(e) Prohibited Uses (All uses other than those listed as principal, accessory, or conditional uses or substantially similar to principal, accessory, or conditional uses shall be prohibited. The uses below are provided for illustration purposes and for the purpose of limiting permitted uses, and are not intended to be a total listing of all the uses that are prohibited.)

1. As for R-1A.

Lot, Yard, and Height Requirements (See Articles 3, 8-9(o) below, and 15 for additional regulations.)

8-9(f) Lot Size - 4,000 square feet minimum, with a maximum of 7,500 square feet for single family detached uses on lots not fronting upon a cul-de-sac or more than one public street; for all other uses and lots, there shall be no maximum lot size.

8-9(g) Minimum Lot Frontage - 40'.

8-9(h) Minimum Front Yard - 20'.

8-9(i) Minimum Each Side Yard - 3'. No wall, air-conditioning unit, structure or other obstruction shall be located within the required side yard. Any fence located in a required side yard must be entirely to the rear of the principal structure on the lot. (See Article 8-9(o)1 below.)

8-9(j) Minimum Rear Yard - 10'.

8-9(k) Minimum Useable Open Space - No limitation.

8-9(l) Maximum Lot Coverage - No limitation.

8-9(m) Maximum Height of Building - 35'.

8-9(n) Off-Street Parking (See Article 16 for additional parking regulations.)

One space per dwelling unit.

8-9(o) Special Provisions

1. There shall be not less than six (6) feet at any point between the walls of each single family residence.
2. Lot, yard and height requirements for single family detached dwellings in defined Infill and Redevelopment areas are for existing lots as of December 5, 2002, and shall be as follows:
 - a. Where existing lot frontage is 24 feet but less than 40 feet, the provisions of Article 15-7 and the following shall apply:
 1. Minimum lot frontage - 24 feet.
 2. Minimum front yard - As per Article 8-9(h), unless the average depth of the existing front yards on each of the adjacent lots on either side of the lot are less; then the minimum shall be no less than this average, or eight (8) feet, whichever is greater.
 3. Maximum front yard - 40 feet, unless the average depth of the existing front yards on each of the adjacent lots on either side of the lot are greater; then the maximum shall be no greater than this average.
 4. Minimum side yard - As per Article 8-9(i).
 5. Minimum rear yard - 20% of the lot depth.
 6. Minimum usable open space - No limitation.
 7. Minimum lot coverage - No limitation.
 8. Maximum height of building - 28 feet and 2½ stories.
 9. Maximum lot coverage - No limitation.
 10. Maximum floor area ratio - 0.35, or that which allows 2,600 square feet, whichever is greater.
 - b. Where existing lot frontage is 40 feet or greater, the provisions of Article 15-7 and the following shall apply:
 1. Minimum lot frontage - 40 feet.
 2. Minimum front yard - As per Article 8-9(h), unless the average depth of the existing front yards on each of the adjacent lots on either side of the lot are less; then the minimum shall be no less than this average, or eight (8) feet, whichever is greater.

3. Maximum front yard - 40 feet, unless the average depth of the existing front yards on each of the adjacent lots on either side of the lot are greater; then the maximum shall be no greater than this average.
4. Minimum side yard - As per Article 8-12(i).
5. Minimum rear yard - 20% of the lot depth.
6. Minimum usable open space - No limitation.
7. Minimum lot coverage - No limitation.
8. Maximum height of building - 28 feet and 2½ stories.
9. Maximum lot coverage - No limitation.
10. Maximum floor area ratio - 0.35, or that which allows 2,600 square feet, whichever is greater.

8-10 TOWNHOUSE RESIDENTIAL (R-1T) ZONE

8-10(a) Intent - This zone is intended to provide for attached single family dwellings and supporting uses. This zone should be at locations and at the density (units/acre) recommended by the Comprehensive Plan and in areas of the community where necessary services and facilities will be adequate to serve the anticipated population.

8-10(b) Principal Uses (Other uses substantially similar to those listed herein shall also be deemed permitted.)

1. Single family attached residences, except that not more than twelve (12) units shall be attached.
2. Group Residential Projects, as provided in Article 9.
3. Existing single family detached residences and single family detached residences for which a building permit was issued or a plan approved prior to the adoption of this Zoning Ordinance.
4. Parks and playgrounds operated by government.
5. Temporary real estate sales offices for the sale of lots, located only within the subdivision in which said lots are located; to be removed at the end of two years or when all the lots are sold, whichever comes first.

8-10(c) Accessory Uses (Uses and structures which are customarily accessory, clearly incidental and subordinate to permitted uses.)

1. Private garages, storage sheds and parking areas.
2. Swimming pools and tennis courts.
3. Agricultural uses, excluding commercial stock raising.
4. Private, non-commercial parks and open space.
5. Home offices and home occupations.
6. A ground, roof or pole-mounted satellite dish antenna, as regulated in Article 15-8.
7. Family child care for up to six (6) children, provided that the total number of children living or being cared for on the premises shall not exceed six (6).
8. Hiking and bicycling trails.

8-10(d) Conditional Uses (Permitted only with Board of Adjustment approval.)

1. As for R-1A.

8-10(e) Prohibited Uses (All uses other than those listed as principal, accessory, or conditional uses or substantially similar to principal, accessory, or conditional uses shall be prohibited. The uses below are provided for illustration purposes and for the purpose of limiting permitted uses, and are not intended to be a total listing of all the uses that are prohibited.)

1. As for R-1A, except for townhouses.

Lot, Yard, and Height Requirements (See Articles 3, 8-10(o) below, and 15 for additional regulations.)

8-10(f) Minimum Lot Size - 1,500 square feet.

8-10(g) Minimum Lot Frontage - 15'.

8-10(h) Minimum Front Yard - 10' (See 8-10(o) below).

8-10(i) Minimum Each Side Yard (See 8-10(o) below).

8-10(j) Minimum Rear Yard - 10'.

8-10(k) Minimum Useable Open Space (See 8-10(o) below).

8-10(l) Maximum Lot Coverage - No limitation.

8-10(m) Maximum Height of Building - 35'.

8-10(n) Off-Street Parking (See Article 16 for additional parking regulations.)

As for R-1A.

8-10(o) Special Provisions

1. No more than three (3) contiguous townhouse units may be established at the same setback. A variation of at least three (3) feet shall be required where a break in setback occurs. Buildings may penetrate up to eighteen (18) inches over the building line into the required front yard, but the average setback of the contiguous units shall be at least as great as the required front yard.
2. Required side yard shall be six (6) feet for each side yard of townhouses when no units or only one unit fronts on a side yard; and a side yard of twenty (20) feet when more than one unit fronts on that side yard.
3. Not less than ten percent (10%) of the total lot area for any townhouse shall be devoted to private usable open space either on each lot or on land adjacent and directly accessible to each lot. Such open space shall be for the private use of the residents of each individual townhouse and shall be physically separated from other private open space or common open space by plantings, fences, or walls. The least dimension of the private open space shall be eight (8) feet.
4. In addition to the special provisions listed above, the lot, yard and height requirements for attached single family dwellings that are approved by the Planning Commission on a final development plan, in defined Infill and Redevelopment areas, shall be as follows:
 - a. Minimum lot size - As per Article 8-10(f).
 - b. Minimum lot frontage - As per Article 8-10(g).
 - c. Minimum front yard - 5 feet.
 - d. Maximum front yard - 15 feet.
 - e. Minimum yard along an alley - 3 feet.
 - f. Minimum side yard for the end of unattached units - 3 feet. No wall, air-conditioning unit, structure, or other obstruction shall be located within the required side yard. Any fence located in a required side yard must be located behind the front wall plane of the principal structure on the lot.
 - g. Minimum rear yard - 20% of the lot depth.
 - h. Minimum usable open space - As per Article 8-10(o)3 above.
 - i. Minimum lot coverage - No limitation.
 - j. Maximum height of building - As per Article 8-10(m) above.
 - k. Maximum lot coverage - No limitation.

8-11 TWO-FAMILY RESIDENTIAL (R-2) ZONE

8-11(a) Intent - This zone is primarily for two-family dwellings (duplexes). This zone should be at locations and at the density (units/acre) recommended by the Comprehensive Plan and in areas of the community where necessary services and facilities will be adequate to serve the anticipated population.

8-11(b) Principal Uses (Other uses substantially similar to those listed herein shall also be deemed permitted.)

1. As for R-1A.
2. Two-family dwellings.
3. Two-family dwellings, having a common vertical wall on the property line of two separate lots. Only one dwelling for one family shall be permitted on each lot, and no more than two dwelling units shall be attached.

8-11(c) Accessory Uses (Uses and structures which are customarily accessory, clearly incidental and subordinate to permitted uses.)

1. The permitted accessory uses in the R-1A zone.

8-11(d) Conditional Uses (Permitted only with Board of Adjustment approval.)

1. The permitted conditional uses in the R-1A zone.

8-11(e) Prohibited Uses (All uses other than those listed as principal, accessory, or conditional uses or substantially similar to principal, accessory, or conditional uses shall be prohibited. The uses below are provided for illustration purposes and for the purpose of limiting permitted uses, and are not intended to be a total listing of all the uses that are prohibited.)

1. The prohibited uses in the R-1A zone, except for two-family dwellings.

Lot, Yard, and Height Requirements (See Articles 3, 8-11(o) below, and 15 for

additional regulations).

8-11(f) Minimum Lot Size - 7,500 square feet (See 8-11(o) below).

8-11(g) Minimum Lot Frontage - 60' (See 8-11(o) below).

8-11(h) Minimum Front Yard - 30'.

8-11(i) Minimum Each Side Yard - 6' (See 8-11(o) below).

8-11(j) Minimum Rear Yard - 10' or 20% of the lot depth, whichever is greater.

8-11(k) Minimum Usable Open Space - No limitation.

8-11(l) Maximum Lot Coverage - No limitation (See 8-11(o) below).

8-11(m) Maximum Height of Building - 35'.

8-11(n) Off-Street Parking (See Article 16 for additional parking regulations.)

As for R-1A.

Duplexes - Two (2) spaces per dwelling unit.

8-11(o) Special Provisions:

1. The minimum lot size and lot frontage may be reduced for a property subdivision along the common vertical wall of a two-family dwelling (duplex) as long as the structure meets the dwelling unit separation requirements for townhouses under the current Kentucky Building Code.
2. The minimum side yard may be eliminated on one side of a lot, for future or existing adjacent lots, if a common vertical wall dividing a two-family structure is located, or is to be located, on the common property line. The side yard that is not eliminated shall be a minimum of six (6) feet.
3. Lot, yard and height requirements for single family detached dwellings in defined Infill & Redevelopment area shall be as required for R-1D.
4. Lot, yard and height requirements for two-family dwellings in defined Infill & Redevelopment areas are for existing lots as of December 5, 2002, and shall be as follows:
 - a. Minimum lot size - As per Article 8-11(f) and Article 8-11(o)(1) above.
 - b. Minimum lot frontage - As per Article 8-11(g) and Article 8-11(o)(2) above.
 - c. Minimum front yard - As per Article 8-11(h), unless the average depth of the existing front yards on each of the adjacent lots on either side of the lots are less; then the minimum shall be no less than this average, or eight (8) feet, whichever is greater.
 - d. Maximum front yard - 50 feet, unless the average depth of the existing front yards on each of the adjacent lots on either side of the lot are greater; then the maximum shall be no greater than this average.
 - e. Minimum side yard - As per Article 8-11(i) and Article 8-11(o)(3) above.
 - f. Minimum rear yard - As per Article 8-11(j).
 - g. Minimum usable open space - No limitation.
 - h. Minimum lot coverage - No limitation.
 - i. Maximum height of building - As per Article 8-11(m) above.
 - j. Maximum lot coverage - No limitation, except for a floor area ratio of 0.35, or that which allows 2,600 square feet, whichever is greater.
5. Habitable additions to two-family dwellings must have a common wall that shall be at least 15 feet or 25% of the length of the common wall on the existing structure, whichever is greater.

8-12 PLANNED NEIGHBORHOOD RESIDENTIAL (R-3) ZONE

8-12(a) Intent - This zone is primarily for multi-family dwellings and other residential uses. This zone should be at locations and at the density (units/acre) recommended by the Comprehensive Plan, and in areas of the community where necessary services and facilities will be adequate to serve the anticipated population.

8-12(b) Principal Uses (Other uses substantially similar to those listed herein shall also be deemed permitted.)

1. The principal permitted uses in the R-2 zone.
2. Multi-family dwellings.
3. Dormitories.
4. Boarding or lodging houses, assisted living facilities, and hospitality houses for up to eight (8) persons.
5. Community residences.
6. Group Residential Projects, as provided by Article 9.

7. Townhouses, except that no less than three (3) and no more than twelve (12) units shall be attached.

8-12(c) Accessory Uses (Uses and structures which are customarily accessory, clearly incidental and subordinate to permitted uses.)

1. Items 1 through 3 and 6 through 9 of the permitted accessory uses in the R-1A zone.
2. The keeping of not more than four (4) roomers or boarders per dwelling unit by a resident family for single family or two-family dwellings, except where a bed and breakfast facility is provided; then no roomers or boarders shall be permitted.
3. Non-commercial athletic club facilities, when accessory to another permitted or conditional use.

8-12(d) Conditional Uses (Permitted only with Board of Adjustment approval.)

1. The permitted conditional uses in the R-1A zone.
2. Hospitals, nursing homes, personal care facilities, and orphanages.
3. Community centers (such as YMCA, YWCA, etc.)
4. Community garages.
5. Kindergartens, nursery schools, and child care centers for four (4) or more children. A fenced and screened play area shall be provided, which shall contain not less than twenty-five (25) square feet per child.
6. Parking, as permitted in Article 16-3.
7. Sorority and fraternity houses.
8. Boarding or lodging houses, assisted living facilities, and hospitality houses for more than eight (8) persons and rehabilitation homes, provided that no use permitted under this section shall be located less than five hundred (500) feet, as measured from the nearest property line, from another use permitted under this section. However, the Board may reduce the 500-foot spacing requirement if it can determine that a reduction will not have an adverse influence on existing or future development of the subject property or its surrounding neighborhood.
9. Bed and breakfast facilities, limited to the rental of not more than five (5) rooms. The Board of Adjustment, in considering approval of such conditional use, shall consider and make a finding that the number of rooms granted shall not have an adverse effect on surrounding properties. In addition, in considering such a conditional use, the Board of Adjustment shall take into consideration the number of bed and breakfast facilities, if any, within the general neighborhood of the property being considered for such use.
10. Day Shelters.

8-12(e) Prohibited Uses (All uses other than those listed as principal, accessory, or conditional uses or substantially similar to principal, accessory, or conditional uses shall be prohibited. The uses below are provided for illustration purposes and for the purpose of limiting permitted uses, and are not intended to be a total listing of all the uses that are prohibited.)

1. The prohibited uses in the R-1A zone, except for multi-family, two-family and townhouse dwellings; boarding or lodging houses; dormitories; and sorority and fraternity houses.

Lot, Yard, and Height Requirements (See Articles 3, 8-12(o) below, and 15 for additional regulations.)

8-12(f) Minimum Lot Size - 6,000 square feet.

8-12(g) Minimum Lot Frontage - 50'.

8-12(h) Minimum Front Yard - 20'.

8-12(i) Minimum Each Side Yard - 5', unless required to be a minimum of 30 feet by Article 15-2(b)(3).

8-12(j) Minimum Rear Yard - 10'.

8-12(k) Minimum Usable Open Space - 20%.

8-12(l) Maximum Lot Coverage - 25% and a floor area ratio of 0.5.

8-12(m) Maximum Height of Building - 35'.

8-12(n) Off-Street Parking (See Article 16 for additional parking regulations.)

As for R-1A, except as provided in Article 8-12(o)(4) below.

Multiple Family Dwellings (other than Elderly Housing) - Three (3) spaces for every two (2) dwelling units, or 0.9 spaces per bedroom in a multi-family dwelling, whichever is greater.

Elderly Housing - Three (3) spaces for every four (4) dwelling units.

Fraternity and Sorority Houses, Dormitories, Boarding and Lodging Houses and Hospitality Houses - Five (5) spaces, plus one (1) space for every five (5) beds.

Hospitals, Nursing Homes, Personal Care Facilities, Orphanages, and Rehabilitation Homes - One (1) space for every four (4) beds; plus one (1) space for each employee on the maximum working shift, with a minimum of five (5) spaces.

Community Centers - Five (5) spaces, plus one (1) space for each employee.

Bed and Breakfast Facilities - One space per room rented other than the first room.

Assisted Living Facilities - Three (3) spaces for each four (4) bedrooms, plus one (1) space for each employee on the maximum shift.

Duplexes - Two (2) spaces per dwelling unit.

8-12(o) Special Provisions:

1. Lot, yard, and height requirements for townhouses shall be as required for R-1T.
2. Lot, yard, and height requirements for two-family dwellings shall be as required by R-2.
3. Lot, yard, and height requirements for Group Residential Projects shall be as required in Article 9.
4. Lot, yard, and height requirements for single family detached dwellings in defined Infill & Redevelopment areas are for existing lots as of December 5, 2002, and shall be as listed below. (Minimum lot sizes are listed below for the purpose of establishing minimum configurations that may be the result of consolidation among adjacent parcels.)
 - a. Where existing lot frontage is less than 24', the provisions of Article 15-7 and the following shall apply:
 1. Minimum lot size - 2,000 square feet.
 2. Minimum lot frontage - 20 feet.
 3. Minimum front yard - As per Article 8-12(h), unless the average depth of the existing front yards on each of the adjacent lots on either side of the lot are less; then the minimum shall be no less than this average, or eight (8) feet, whichever is greater.
 4. Maximum front yard - 40 feet, unless the average depth of the existing front yards on each of the adjacent lots on either side of the lot are greater; then the maximum shall be no greater than this average.
 5. Minimum side yard - 3 feet. No wall, air-conditioning unit, structure, or other obstruction shall be located within the required side yard. Any fence located in a required side yard must be entirely to the rear of the principal structure on the lot.
 6. Minimum rear yard - 20 feet.
 7. Minimum usable open space - No limitation.
 8. Minimum lot coverage - No limitation.
 9. Maximum height of building - 24 feet.
 10. Maximum lot coverage - No limitation.
 11. Maximum floor area ratio - 0.35, or that which allows 2,600 square feet, whichever is greater.
 12. Minimum off-street parking - None required.
 - b. Where existing lot frontage is 24' but less than 35', the provisions of Article 15-7 and the following shall apply:
 1. Minimum lot size - 2,500 square feet.
 2. Minimum lot frontage - 24 feet.
 3. Minimum front yard - As per Article 8-12(h), unless the average depth of the existing front yards on each of the adjacent lots on either side of the lot are less; then the minimum shall be no less than this average, or eight (8) feet, whichever is greater.
 4. Maximum front yard - 40 feet, unless the average depth of the existing front yards on each of the adjacent lots on either side of the lot are greater; then the maximum shall be no greater than this average.
 5. Minimum side yard - 3 feet. No wall, air-conditioning unit, structure, or other obstruction shall be located within the required side yard. Any fence located in a required side yard must be entirely to the rear of the principal structure on the lot.
 6. Minimum rear yard - 20% of the lot depth.

7. Minimum usable open space - No limitation.
 8. Minimum lot coverage - No limitation.
 9. Maximum height of building - 28 feet and 2½ stories.
 10. Maximum lot coverage - No limitation.
 11. Maximum floor area ratio - 0.35, or that which allows 2,600 square feet, whichever is greater.
- c. Where existing lot frontage is 35' but less than 50', the provisions of Article 15-7 and the following shall apply:
1. Minimum lot size - 3,750 square feet.
 2. Minimum lot frontage - 35 feet.
 3. Minimum front yard - As per Article 8-12(h), unless the average depth of the existing front yards on each of the adjacent lots on either side of the lot are less; then the minimum shall be no less than this average, or eight (8) feet, whichever is greater.
 4. Maximum front yard - 40 feet, unless the average depth of the existing front yards on each of the adjacent lots on either side of the lot are greater; then the maximum shall be no greater than this average.
 5. Minimum side yard - As per Article 8-12(i).
 6. Minimum rear yard - 20% of the lot depth.
 7. Minimum usable open space - No limitation.
 8. Minimum lot coverage - No limitation.
 9. Maximum height of building - 28 feet and 2½ stories.
 10. Maximum lot coverage - No limitation.
 11. Maximum floor area ratio - 0.35, or that which allows 2,600 square feet, whichever is greater.
- d. Where existing lot frontage is 50 feet or greater, the provisions of Article 15-7 and the following shall apply:
1. Minimum lot size - 8,000 square feet.
 2. Minimum lot frontage - 50 feet.
 3. Minimum front yard - As per Article 8-12(h), unless the average depth of the existing front yards on each of the adjacent lots on either side of the lot are less; then the minimum shall be no less than this average, or eight (8) feet, whichever is greater.
 4. Maximum front yard - 40 feet, unless the average depth of the existing front yards on each of the adjacent lots on either side of the lot are greater; then the maximum shall be no greater than this average.
 5. Minimum side yard - 8 feet.
 6. Minimum rear yard - 20% of the lot depth.
 7. Minimum usable open space - No limitation.
 8. Minimum lot coverage - No limitation.
 9. Maximum height of building - As per Article 8-12(m).
 10. Maximum lot coverage - No limitation.
 11. Maximum floor area ratio - 0.7.
5. Lot, yard and height requirements for all other single family detached dwellings in the R-3 zone shall be as follows:
- (1) Minimum lot size - 2,500 square feet.
 - (2) Minimum lot frontage - 25 feet.
 - (3) Minimum front yard - 20 feet, as per Article 8-12(h).
 - (4) Minimum side yard - 3 feet. No wall, air-conditioning unit, structure, or other obstruction shall be located within the required side yard. Any fence located in a required side yard must be entirely to the rear of the principal structure on the lot.
 - (5) Minimum rear yard - 10 feet.
 - (6) Minimum usable open space - No limitation.
 - (7) Maximum lot coverage - No limitation.
 - (8) Maximum height of building - 35 feet.

8-13 HIGH DENSITY APARTMENT (R-4) ZONE

8-13(a) Intent - This zone is primarily for multi-family dwellings, but at a higher density than the R-3 zone. The R-4 zone should be at locations and at the density (units/acre) recommended by the Comprehensive Plan, and in areas of the community where necessary services and facilities will be adequate to serve the anticipated population.

8-13(b) Principal Uses (Other uses substantially similar to those listed herein shall also be deemed permitted.)

1. The principal permitted uses in the R-3 zone.

8-13(c) Accessory Uses (Uses and structures which are customarily accessory, clearly

incidental and subordinate to permitted uses.)

1. The permitted accessory uses in the R-3 zone.

8-13(d) Conditional Uses (Permitted only with Board of Adjustment approval.)

1. The permitted conditional uses in the R-3 zone.

8-13(e) Prohibited Uses (All uses other than those listed as principal, accessory, or conditional uses or substantially similar to principal, accessory, or conditional uses shall be prohibited. The uses below are provided for illustration purposes and for the purpose of limiting permitted uses, and are not intended to be a total listing of all the uses that are prohibited.)

1. The prohibited uses in the R-3 zone.
2. Equine trails.

Lot, Yard, and Height Requirements (See Articles 3, 8-13(o) below, and 15 for additional regulations.)

8-13(f) Minimum Lot Size - 6,000 square feet.

8-13(g) Minimum Lot Frontage - 50 feet.

8-13(h) Minimum Front Yard - 20 feet.

8-13(i) Minimum Each Side Yard - 5 feet.

8-13(j) Minimum Rear Yard - 10 feet.

8-13(k) Minimum Useable Open Space - 20%.

8-13(l) Maximum Lot Coverage - 30% and a floor area ratio of 0.7.

8-13(m) Maximum Height of Building - 2:1 height-to-yard ratio, except that buildings under 35' may have side and rear yards as required in the R-3 zone.

8-13(n) Off-Street Parking (See Article 16 for additional parking regulations.)

As for R-3.

8-13(o) Special Provisions

1. Lot, yard, and height requirements for townhouses shall be as required for R-1T.
2. Lot, yard, and height requirements for two-family dwellings shall be as required by R-2.
3. Lot, yard, and height requirements for Group Residential Projects shall be as provided in Article 9.
4. Lot, yard, and height requirements for single family detached dwellings shall be as provided in Section 8-12(o): Special Provisions of the R-3 zone.

8-14 HIGH RISE APARTMENT (R-5) ZONE

8-14(a) Intent - This zone is primarily for multi-family dwellings and particularly for high rise apartments. The R-5 zone should be at locations and at the density (units/acre) recommended by the Comprehensive Plan, and in areas of the community where necessary services and facilities will be adequate to serve the anticipated population.

8-14(b) Principal Uses (Other uses substantially similar to those listed herein shall also be deemed permitted.)

1. Multi-family dwellings.
2. Dormitories.
3. Offices, limited to multi-family structures with six (6) or more stories, provided offices are limited to no more than the first two stories with no mixing of offices and apartments on the same floor.
4. Temporary real estate sales offices for the sale of lots, located only within the subdivision in which said lots are located; to be removed at the end of two years or when all the lots are sold, whichever comes first.

8-14(c) Accessory Uses (Uses and structures which are customarily accessory, clearly incidental and subordinate to permitted uses.)

1. The permitted accessory uses in the R-1A zone, items 1 through 3 and 6 through 9.

2. Athletic club facilities, when accessory to another permitted or conditional use.
3. Incidental retail uses to any permitted use, but having no primary access to the exterior; and limited to a maximum of ten percent (10%) of the gross floor area of the building in which it is located, with no single such use being in excess of 5,000 square feet.

8-14(d) Conditional Uses (Permitted only with Board of Adjustment approval.)

1. The permitted conditional uses in the R-3 zone.
2. Extended-stay hotels.
3. Restaurants, without a cocktail lounge, live entertainment and/or dancing, provided it meets the following conditions:
 - a. It shall be located in a building containing a minimum of 100 dwelling units.
 - b. It shall occupy no more than ten percent (10%) of the gross floor area of the building it occupies.
 - c. It shall have no primary access to the exterior; however, one service entrance directly to the outside of the building may be permitted.
 - d. It shall have no drive-in or drive-through food service.
 - e. There shall be no more than two restaurants within a building, provided that the 10% limitation is not exceeded.
 - f. None of its public floor area may be devoted exclusively to the preparation and service of malt beverages, wine or alcoholic beverages.
 - g. Signs permitted per multi-family residential building may be used to identify the restaurant.
 - h. This shall not apply to extended-stay hotels.

8-14(e) Prohibited Uses (All uses other than those listed as principal, accessory, or conditional uses or substantially similar to principal, accessory, or conditional uses shall be prohibited. The uses below are provided for illustration purposes and for the purpose of limiting permitted uses, and are not intended to be a total listing of all the uses that are prohibited.)

1. The prohibited uses in the R-4 zone, except for offices, as permitted herein, extended-stay hotels, and incidental retail uses.
2. Outdoor commercial and non-commercial recreational facilities, such as zoological gardens, sportsmen's farms, riding stables and equine trails.

Lot, Yard, and Height Requirements (See Articles 3 and 15 for additional regulations.)

8-14(f) Minimum Lot Size - 6,000 square feet.

8-14(g) Minimum Lot Frontage - 50 feet.

8-14(h) Minimum Front Yard - 20 feet.

8-14(i) Minimum Each Side Yard - 10 feet.

8-14(j) Minimum Rear Yard - 10 feet.

8-14(k) Minimum Usable Open Space - 20%.

8-14(l) Maximum Lot Coverage - 35% and a floor area ratio of 1.3.

8-14(m) Maximum Height of Building - 4:1 height-to-yard ratio.

8-14(n) Off-Street Parking (See Article 16 for additional parking regulations.)

As for R-3

Accessory Offices - One (1) space for every two hundred (200) square feet of floor area, with a minimum of three (3) spaces per office tenant.

Extended-Stay Hotels - One (1) space for every dwelling unit, plus one (1) space for each employee on the maximum shift.

8-15 PROFESSIONAL OFFICE (P-1) ZONE

8-15(a) Intent - This zone is primarily for offices and related uses. Retail sales are prohibited, except where directly related to office functions. This zone should be located as recommended in the Comprehensive Plan.

8-15(b) Principal Uses (Other uses substantially similar to those listed herein shall also be deemed permitted.)

1. Banks, credit agencies, security and commodity brokers and exchanges, credit

- institutions, savings and loan companies, holding and investment companies.
2. Offices for business, professional, governmental, civic, social, fraternal, political, religious, and charitable organizations, including, but not limited to, real estate sales offices.
 3. Research development and testing laboratories or centers.
 4. Schools for academic instruction.
 5. Libraries, museums, art galleries, and reading rooms.
 6. Funeral parlors.
 7. Medical and dental offices, clinics, and laboratories.
 8. Telephone exchanges, radio and television studios.
 9. Studios for work or teaching of fine arts, such as photography; music; drama; dance and theater.
 10. Community centers and private clubs.
 11. Hospitals, nursing homes, personal care facilities and assisted living facilities.
 12. Computer and data processing centers.
 13. Ticket and travel agencies.
 14. Kindergartens, nursery schools and child care centers for four (4) or more children. A fenced and screened play area shall be provided, which shall contain not less than twenty-five (25) square feet per child.
 15. Cable television system signal distribution centers and studios.
 16. Dwelling units, provided the units are not located on the first floor of a structure and provided that at least the first floor is occupied by another permitted use or uses in the P-1 zone, with no mixing of other permitted uses and dwelling units on any floor.
 17. Business colleges, technical or trade schools or institutions.
 18. Athletic club facilities, when located at least one hundred fifty (150) feet from a residential zone.
 19. Beauty shops and barber shops not exceeding 2,000 square feet in floor area, which employ not more than five licensed cosmetologists, with all service provided only by licensed cosmetologists and/or barbers.
 20. Rehabilitation homes, but only when more than five hundred (500) feet from a residential zone.
 21. Adult day care centers.
 22. Day Shelters.
 23. Places of religious assembly.
 24. Offices of veterinarians, animal hospitals or clinics, provided that (a) all exterior walls are completely soundproofed; (b) animal pens are located completely within the principal building; and (c) boarding is limited to only animals receiving medical treatment.

8-15(c) Accessory Uses (Uses and structures which are customarily accessory, clearly incidental and subordinate to permitted uses.)

1. Establishments limited to the filling of prescriptions and retail sale of pharmaceutical and medical supplies.
2. Parking areas or structures.
3. Incidental retail sales or personal services, including facilities for serving food, only for employees, residents or visitors to any permitted use, and having no primary access to the exterior; and limited to a maximum of ten percent (10%) of the gross floor area of the building in which it is located, with no single such use being in excess of 5,000 square feet.
4. Sales offices for the display of merchandise and the acceptance of orders.
5. Swimming pools, tennis courts, putting greens, hiking and bicycling trails, botanical gardens, nature preserves and other similar non-commercial recreational uses.
6. Satellite dish antennas, as further regulated by Article 15-8.
7. One dwelling unit for owners, operators, or employees of a permitted use, provided that such dwelling unit shall be part of the building and located above, to the side, or to the rear of such permitted use.
8. Retail sales and storage areas accessory to internet-based businesses, for which Certificates of Occupancy are issued after November 15, 2001; provided that the retail sales and storage area occupies no more than twenty-five percent (25%) of the business area, nor more than 2,500 square feet, whichever is less; and having no display space, storage space or signs visible from the exterior of the building.
9. Drive-through facilities for the sale of goods or products or the provision of services otherwise permitted herein, when approved by the Planning Commission on a development plan.

8-15(d) Conditional Uses (Permitted only with Board of Adjustment approval.)

1. Drive-through facilities for sale of goods or products or the provision of services otherwise permitted herein.
2. Parking lots and structures.
3. Mining of non-metallic minerals, but only when the proposal complies with the requirements of the Mining/Quarrying Ordinance (Code of Ordinances #252-91) and the conditions and requirements as set forth therein. The Board of Adjustment shall specifically consider and be able to find:

- a. That the proposed use will not constitute a public nuisance by creating excessive noise, odor, traffic, dust, or damage to the environment or surrounding properties;
 - b. That a reasonable degree of reclamation and proper drainage control is feasible; and
 - c. That the owner and/or applicant has not had a permit revoked or bond or other security forfeited for failure to comply with any Federal, State or local laws, regulations or conditions, including land reclamation, pertaining to the proposed use.
4. Rehabilitation homes, when located closer than five hundred (500) feet from a residential zone.
 5. Extended-stay hotels, except as permitted in a Professional Office Project.
 6. Mail service facilities, except as permitted in a Professional Office Project.
 7. Ecotourism activities to include equine or zip line trails; tree canopy tours; canoeing and kayaking launch sites; fishing clubs; and seasonal activities.

8-15(e) Prohibited Uses (All uses other than those listed as principal, accessory, or conditional uses or substantially similar to principal, accessory, or conditional uses shall be prohibited. The uses below are provided for illustration purposes and for the purpose of limiting permitted uses, and are not intended to be a total listing of all the uses that are prohibited.)

1. As for A-R, except offices, institutional uses, dwelling units, and other uses as permitted herein.
2. Any use dependent upon septic tanks or pit privies.
3. Pawn shops.
4. Golf driving ranges.
5. The above- or below-ground storage of any flammable material in gaseous form, including compressed natural gas; and the above- or below-ground storage of more than five (5) gallons of gasoline. However, jet fuel may be stored only in conjunction with a heliport.
6. Greenhouses, plant nurseries, market gardens and garden centers.
7. Tattoo parlors.
8. Ecotourism activities, except as permitted herein.

Lot, Yard, and Height Requirements (See Articles 3 and 15 for additional regulations.)

8-15(f) Minimum Lot Size - 7,500 square feet.

8-15(g) Minimum Lot Frontage - 60 feet.

8-15(h) Minimum Front Yard - 20 feet.

8-15(i) Minimum Each Side Yard - 12 feet.

8-15(j) Minimum Rear Yard - 12 feet.

8-15(k) Minimum Usable Open Space - No limitation, except where residences are provided, then 10%.

8-15(l) Maximum Lot Coverage - 35% and a floor area ratio of 1.3.

8-15(m) Maximum Height of Building - 3:1 height-to-yard ratio.

8-15(n) Off-Street Parking (See Article 16 for additional parking regulations.)

Athletic Club Facilities - One (1) space for every two hundred (200) square feet of floor area, plus one (1) space for each employee on the maximum working shift.

Offices, Fine Arts Studios, Banks and Financial Establishments, Offices of Veterinarians, and Animal Hospitals, Medical and Dental Offices, Clinics and Laboratories, and the like - One (1) space for each two hundred (200) square feet of floor area.

Telephone Exchanges, Radio and Television Stations - One (1) space for every two (2) employees on a maximum shift; plus one (1) space for each vehicle owned by the use, with a minimum of five (5) spaces.

Elementary and Junior High Schools - One (1) space for every fifteen (15) auditorium seats; or one (1) space for each classroom, plus one (1) space for each employee, whichever is greater.

All Other Schools for Academic Instruction - One (1) space for every five (5) main auditorium seats, or one (1) space for every five (5) gymnasium seats, or one (1) space for every five (5) classroom seats, whichever is greater.

Professional Office Projects - One (1) space for every four hundred (400) square feet of floor area.

Kindergartens, Nursery Schools, and Child Care Centers - Three (3) spaces for the first twelve (12) children, plus one (1) space for every ten (10) (or fraction thereof) additional children.

Places of Religious Assembly - One (1) space for each five (5) seats in the main auditorium, with a minimum of five (5) spaces.

Libraries, Museums, Community Centers, Art Galleries and Reading Rooms - One (1) space for each six hundred (600) square feet of floor area.

Funeral Parlors - One (1) space for every five (5) seats under maximum occupancy, plus one (1) for each vehicle owned by the use.

Dwelling Units - One (1) space for each dwelling unit.

Private Clubs - One (1) space for every four (4) members.

Accessory Retail Facilities - One (1) space for every six hundred (600) square feet of floor area for each retail use.

Restaurants - One (1) space for each two hundred (200) square feet of floor area; or one (1) for every four (4) indoor seats plus one (1) for every eight (8) outdoor seats, whichever is greater.

Hospitals, Nursing Homes, Personal Care Facilities and Rehabilitation Homes - One (1) space for every three (3) beds; plus one (1) space for each employee on the maximum working shift, with a minimum of five (5) spaces.

Assisted Living Facilities - Three (3) spaces for each four (4) bedrooms, plus one (1) space for each employee on the maximum shift.

Extended-Stay Hotels - One (1) space for every dwelling unit, plus one (1) space for each employee on the maximum shift.

Adult Day Care Center - One (1) space for every ten (10) persons being provided care, plus one (1) space per caregiver on the maximum shift.

Day Shelter - One (1) space for every ten (10) persons being provided services, plus one (1) space per staff member on the maximum shift.

Beauty Shops or Barber Shops - One (1) space for every 200 square feet, with a minimum of three (3) spaces.

Mail Service Facilities - One (1) space for each 200 square feet of floor area.

Other Recreational Facilities or Ecotourism activities not otherwise stated herein – Five (5) spaces, plus one (1) space for each employee for each separate use.

Conditional Uses - Parking requirements stated herein for conditional uses are minimum requirements; the Board of Adjustment may establish additional requirements as needed.

Combinations - Combined uses shall provide parking equal to the sum of the individual requirements.

8-15(o) Special Provisions

1. A Professional Office Project may be permitted by the Planning Commission for a tract of land with a minimum of ten (10) acres, upon the approval of a preliminary development plan and a final development plan as provided in Article 21, and subject to the P-1 zone regulations.

Subdivision of land in a Professional Office Project is permitted, subject to the following regulations:

- a. There shall be no minimum lot size, lot frontage, yard or open space, nor maximum lot coverage or height requirements for each subdivided lot; however, all said requirements for the approved final development plan shall be applicable to the subdivision.
- b. Each subdivided lot shall have access to adjacent streets or joint parking areas,

as provided by appropriate easements shown on the final development plan and the final record plan.

In addition to the uses otherwise permitted in the Professional Office zone, the following uses shall be permitted in the Professional Office Project:

As a principal permitted use:

1. Extended-Stay Hotels.
2. Mail Service Facilities.

As accessory uses:

1. Receiving, shipping, and storage of new fixtures, equipment and other non-perishable materials for distribution to corporate or affiliated units subsidiary to the tenant(s) of a principal structure. Such activity, including loading and unloading, shall be conducted entirely within the walls of the principal structure and shall be limited to a maximum of twenty percent (20%) of the total floor area of said principal structure.
2. Shoe repair, clothing alteration or tailoring services.

As conditional uses:

1. Helistops and heliports, provided such facilities conform to the requirements of all appropriate Federal, State and local regulations.
2. Beauty shops and barber shops, with no restrictions.

In addition to the uses otherwise permitted in the Professional Office zone, the following accessory use shall be permitted in a P-1 area of at least twenty (20) contiguous acres:

Restaurant(s), with or without a cocktail lounge, entertainment, dancing, and sale of alcoholic beverages, provided it meets the following conditions:

- a. It shall be located in an office building containing a minimum of 40,000 square feet of floor area.
 - b. It shall occupy not more than twenty-five percent (25%) of the building in which it is located.
 - c. It shall have no more than one public entrance and one service entrance directly to the outside of the building, and that this use shall be at least one hundred fifty (150) feet from any residential zone.
 - d. It shall have no drive-in or drive-through food service.
 - e. There shall be no more than two restaurants within an office building, provided that the 25% limitation is not exceeded.
 - f. Signs permitted per office building may be used to identify the restaurant and/or the office use.
2. Where dwelling units are provided and the Planning Commission has approved a final development plan, the required parking spaces may be reduced, when specific permission is given by the Commission to reduce said required parking by not more than one percent (1%) for each one percent (1%) of additional useable open space that is provided over the minimum. Also, for every one percent (1%) of the dwelling units that will be provided as a mixed-income housing unit, the Commission may decrease the required parking by one percent (1%). In any case, the maximum parking reduction shall not exceed the minimum parking otherwise required in the zone by more than ten percent (10%) by only providing additional open space or only providing mixed-income housing, or twenty-five percent (25%) by using a combination of mixed-income housing and additional open space.

8-16 NEIGHBORHOOD BUSINESS (B-1) ZONE

8-16(a) Intent - This zone is intended to accommodate neighborhood shopping facilities to serve the needs of the surrounding residential area. Generally, they should be planned facilities and should be located as recommended in the Comprehensive Plan. This zone should be oriented to the residential neighborhood, and should have a roadway system which will be adequate to accommodate the anticipated vehicular traffic.

8-16(b) Principal Uses (Other uses substantially similar to those listed herein shall also be deemed permitted.)

1. Banks, credit agencies, security and commodity brokers and exchanges, credit institutions, savings and loan companies, holding and investment companies.
2. Offices for business, professional, govern- mental, civic, social, fraternal, political, religious and charitable organizations; including, but not limited to, real estate sales offices.
3. Research development and testing laboratories or centers.
4. Schools for academic instruction.
5. Libraries, museums, art galleries and reading rooms.

6. Funeral parlors.
7. Medical and dental offices, clinics and laboratories.
8. Telephone exchanges, radio and television studios.
9. Studios for work or teaching of fine arts, such as photography; music; drama; dance and theater.
10. Community centers and private clubs.
11. Nursing homes, personal care facilities and assisted living facilities.
12. Computer and data processing centers.
13. Ticket and travel agencies.
14. Kindergartens, nursery schools and child care centers for four (4) or more children. A fenced and screened play area shall be provided, which shall contain not less than twenty-five (25) square feet per child.
15. Business colleges, technical or trade schools or institutions.
16. Rehabilitation homes; but only when more than 500 feet from a residential zone, school for academic instruction or a child care center.
17. Establishments for the retail sale of food products, such as supermarkets; dairy, bakery, meat, beer, liquor, and wine and other food product stores; and provided that production of food products is permitted only for retail sale on the premises.
18. Restaurants, and brew-pubs, except as prohibited under Sections 8-16(e)(14) and (15), which offer no live entertainment or dancing.
19. Establishments for the retail sale of merchandise, including: clothing, shoes, fabrics, yard goods; fixtures, furnishings, and appliances, such as floor covering, radios, TV, phonograph products and other visual and sound reproduction or transmitting equipment; furniture; kitchen and laundry equipment; glassware and china; and other establishments for the retail sale of hardware and wallpaper, lawn care products, paint and other interior or exterior care products, hobby items, toys, gifts, antiques, newspapers and magazines, stationery and books, flowers, music, cameras, jewelry and luggage, business supplies and machines; sporting goods and recreational equipment; prescription and non-prescription medicines and medical supplies.
20. Beauty shops and barber shops.
21. Shoe repair, clothing alterations and tailoring services.
22. Self-service laundry or laundry pick-up stations, including clothes cleaning establishments of not more than 40 pounds capacity and using a closed-system process.
23. Automobile service stations, provided such use conforms to all requirements of Article 16.
24. Parking structures; provided such use conforms to the conditions of Article 16, and provided that at least twenty-five percent (25%) of the first floor is occupied by another permitted use or uses in the B-1 zone.
25. Repair of household appliances.
26. Retail sale of plant nursery or greenhouse products, except as prohibited herein.
27. Miniature golf or putting courses.
28. Quick copy services utilizing xerographic or similar processes, but not utilizing offset printing methods.
29. Carnivals, special events, festivals, or concerts on a temporary basis; and upon issuance of a permit by the Divisions of Planning and Building Inspection, which may restrict the permit in terms of time, parking, access, or in other ways to protect public health, safety, or welfare; or deny such if public health, safety, or welfare is adversely affected. A carnival, special events, festivals, or concerts may not displace more than twenty-five percent (25%) of the minimum required parking for the site it occupies.
30. Indoor theaters, limited to three screens or stages.
31. Rental of equipment whose retail sale would be permitted in the B-1 zone.
32. Dwelling units, provided the units are not located on the first floor of a structure; and provided that at least the first floor is occupied by another permitted use or uses in the B-1 zone, with no mixing of other permitted uses and dwelling units on any floor.
33. Arcades, including pinball and electronic games.
34. Pawnshops, which: (1) were in operation prior to August 31, 1990 and in compliance with the provisions of KRS 226.010 et seq. and Code of Ordinances, Sections 13-52 and 13-53; or (2) had on file with the Lexington-Fayette Urban County Government, prior to August 31, 1990, an application for a business license or certificate of occupancy.
35. Athletic club facilities.
36. Banquet facilities.
37. Adult day care centers.
38. Animal grooming facilities.
39. Mail service facilities.
40. Tattoo parlors.
41. Form-based neighborhood business project, as per 8-16(o)(3).
42. Day Shelters.
43. Commercial farm markets and market gardens.
44. Establishments primarily engaged in agricultural sales and services, but only when

located within 500 feet of an Agricultural Rural (A-R) zone.

45. Ecotourism activities to include hiking, bicycling and equine trails; recreational outfitters, and canoeing and kayaking launch sites.
46. Places of religious assembly.
47. Offices of veterinarians, animal hospitals or clinics, provided that (a) all exterior walls are completely soundproofed; (b) animal pens are located completely within the principal building; and (c) boarding is limited to only animals receiving medical treatment.

8-16(c) Accessory Uses (Uses and structures which are customarily accessory, clearly incidental and subordinate to permitted uses.)

1. Parking areas or structures.
2. One (1) dwelling unit for owners, operators, or employees of a permitted use, provided that such dwelling unit shall be a part of the building and located above or to the rear of such permitted uses.
3. Warehousing, wholesaling, and storage, excluding outdoor storage; and provided that no building for such accessory use shall have openings other than stationary windows or solid pedestrian doors within 100 feet of any residential zone.
4. The sale of malt beverages, wine or alcoholic beverages, when accessory to a restaurant permitted under Section 8-16(b)(3). Such accessory use shall not devote more than twenty-five percent (25%) of its public floor area primarily to the preparation and service of such beverages, nor provide any separate outside entrances or separate identification signs for those areas.
5. Satellite dish antennas, as further regulated by Article 15-8.
6. One or two pool or billiard tables within an establishment.
7. Sidewalk cafes, when accessory to any permitted restaurant.
8. Retail sale of liquid propane (limited to 20-lb. containers), when accessory to the retail sale of merchandise or an automobile service station permitted under Article 8-16(b).
9. Indoor live entertainment and/or dancing, when accessory to a restaurant, brew-pub or banquet facility; but only when located more than 100 feet from a residential zone.
10. Drive-through facilities for the sale of goods or products, or the provision of services otherwise permitted herein, when approved by the Planning Commission on a development plan.

8-16(d) Conditional Uses (Permitted only with Board of Adjustment approval.)

1. Self-service car washes, provided that surface water from such establishments shall not drain onto adjacent property, and that adequate on-site storage lanes and parking facilities shall be provided so that no public way shall be used for such purposes.
2. The rental of trucks (single rear axle - 28' maximum overall length), trailers and related items in conjunction with the operation of an automobile service station; provided that the service station abuts a state or federal highway. No more than five (5) trucks shall be stored for longer than 48 hours on any service station. A site plan shall be submitted for the approval of the Board of Adjustment for the continued control of such activity and shall show the entire property, buildings, signs, parking and location of the proposed storage area.
3. A restaurant or brew-pub, without live entertainment or dancing, which devotes more than twenty-five percent (25%) of its public floor area primarily to the preparation and service of malt beverages, wine or alcoholic beverages.
4. Outdoor live entertainment and/or dancing, cocktail lounges or nightclubs [unless prohibited under Sections 8-16(e)(14) and (15)]. Such uses shall be located at least 100 feet from any residential zone; and indoor uses shall be sound-proofed to the maximum extent feasible by using existing technology, with noise or other emissions not creating a nuisance to the surrounding neighborhood. The Board may also impose time restrictions to minimize nuisance to the surrounding neighborhood.
5. Indoor live entertainment and/or dancing, when accessory to a restaurant, brew-pub or banquet facility; but only when located closer than 100 feet from a residential zone.
6. Upholstery shop.
7. Mining of non-metallic minerals, but only when the proposal complies with the requirements of the Mining/Quarrying Ordinance (Code of Ordinances #252-91) and the conditions and requirements as set forth therein. The Board of Adjustment shall specifically consider and be able to find:
 - a. That the proposed use will not constitute a public nuisance by creating excessive noise, odor, traffic, dust, or damage to the environment or surrounding properties;
 - b. That a reasonable degree of reclamation and proper drainage control is feasible; and
 - c. That the owner and/or applicant has not had a permit revoked or bond or other security forfeited for failure to comply with any Federal, State or local laws,

regulations or conditions, including land reclamation, pertaining to the proposed use.

8. Gasoline pumps available to the public without an employee on site, provided a plan is approved by the Board of Adjustment for periodic inspection of the site by an employee for the following purposes:
 - a. To check all operating equipment;
 - b. To check fire suppression system(s);
 - c. To check the condition of the fire alarm(s);
 - d. To check for indications of fuel leaks and spillage;
 - e. To remove trash from the site;
 - f. To monitor the general condition of the site.
9. Rehabilitation homes, but only when located closer than 500 feet from a residential zone, school for academic instruction or a child care center.
10. Temporary structures designed for use or occupancy for 61 to 180 days per 12-month period on a single property, calculating said period by cumulative consideration of the use of any and all such structures on a single property.
11. Circuses, provided all structures are located not less than 200 feet from any residential zone; and further provided that all structures for housing animals shall be two hundred (200) feet from any residential zone, residential use, school, hospital, nursing or rest home. A circus may not displace more than twenty-five percent (25%) of the minimum required parking for the site it occupies.
12. Automobile and vehicle refueling stations, provided such uses conform to all requirements of Article 16.
13. Extended-stay hotels.
14. Parking lots, provided such use conforms to the conditions of Article 16.
15. Drive-through facilities for the sale of goods or products, or the provision of services otherwise permitted herein, except as accessory uses herein.
16. Ecotourism activities to include zip line trails; tree canopy tours; fishing clubs; botanical gardens; nature preserves; and seasonal activities.
17. Recreation vehicle and trailer campgrounds, but only when located within 500 feet of an interstate interchange.
18. Hunting clubs, but only when located more than 500 feet from a residential zone.
19. Country inns, but only when located within 500 feet of an Agricultural Rural (A-R) zone.

8-16(e) Prohibited Uses (All uses other than those listed as principal, accessory, or conditional uses shall be prohibited. The uses below are provided for illustration purposes and for the purpose of limiting permitted uses, and are not intended to be a total listing of all the uses that are prohibited.)

1. Establishments primarily engaged in agricultural sales and services, except as permitted herein.
2. Warehouses, as well as storage uses, except as accessory uses herein.
3. Shops of special trade and general contractors, such as plumbing; heating; carpentry; masonry; plastering; painting; metal work; printing; electrical; sign painting; tile, mosaic and terrazzo work; electroplating; drilling; excavating; wrecking; construction; and paving. This is not intended to prohibit the administrative offices of such.
4. Manufacturing, compounding, assembling, bottling, processing and packaging and other industrial uses for sale or distribution other than as retail on the premises.
5. Truck terminals and freight yards; transfer stations.
6. Amusement enterprises, such as outdoor theaters; automobile racing; horse racing.
7. Kennels, outdoor runways, or pens for animals.
8. Establishments engaged in the display, rental, sales, service and major repair of automobiles, repair of motorcycles, boats, trucks, travel trailers, farm implements, contractors' equipment, mobile homes, and establishments primarily engaged in the sale of supplies and parts for any of the above-mentioned vehicles or equipment, except as permitted herein.
9. Establishments for cleaning, dyeing, laundering and the like, other than self-service and pickup stations, except for clothes cleaning establishments of not more than forty (40) pounds capacity and using a closed-system process.
10. Dwellings, except as permitted herein.
11. Hotel or motel, boarding house.
12. Wholesale establishments.
13. Greenhouses, nurseries, hatcheries.
14. Establishments offering live entertainment in which a person simulates any sexual act or in which a person is unclothed, or in such attire, costume, or clothing as to expose to view any portion of the female breast below the top of the areola, the male or female genitalia, or the buttocks.
15. Establishments at which any employee is unclothed or in the attire, costume or clothing described above, or is clothed in such a manner as to simulate the breast, genitalia, buttocks, or any portion thereof.
16. Establishments having as a substantial or significant portion of their stock in trade for sale, rent or display: pictures, books, periodicals, magazines, appliances and

similar material, which are distinguished or characterized by their emphasis on matter depicting, describing or relating to such sexual activities as (a) depiction of human genitals in a state of sexual stimulation or arousal; (b) acts of human masturbation, sexual intercourse or sodomy; or (c) holding or other erotic touching of human genitals, pubic region, buttocks or breasts.

17. Indoor motion picture theaters having as a substantial or significant portion of their use the presentation of material having as a dominant theme or characterized or distinguished by an emphasis on matter depicting, describing or relating to such sexual activities as (a) depiction of human genitals in a state of sexual stimulation or arousal; (b) acts of human masturbation, sexual intercourse or sodomy; or (c) holding or other erotic touching of human genitals, pubic region, buttocks or breasts.
18. Above- or below-ground storage of any flammable material in gaseous form, including compressed natural gas.
19. Pawnshops, except as permitted herein.
20. Pool or billiard halls.
21. Hospitals.
22. Ecotourism activities, except as permitted herein.

Lot, Yard, and Height Requirements (See Articles 3 and 15 for additional regulations.)

8-16(f) Minimum Lot Size - No limitation.

8-16(g) Minimum Lot Frontage - No limitation.

8-16(h) Minimum and Maximum Front Yard:

- a. Minimum - 10 feet.
- b. Maximum - 20 feet.

8-16(i) Minimum Each Side Yard - No limitation.

8-16(j) Minimum Rear Yard - No limitation.

8-16(k) Minimum Usable Open Space - No limitation, except where dwelling units are provided as principal uses; then 10%.

8-16(l) Maximum Lot Coverage - No limitation.

8-16(m) Maximum Height of Building - 35 feet, except as permitted in Section 8-16(o)(3).

8-16(n) Off-Street Parking (See Article 16 for additional parking regulations.)
As for P-1.

Accessory Warehousing, Wholesaling, Storage and the like - One (1) space for every 600 square feet of floor area.

Accessory Dwellings - One (1) space per dwelling unit.

Shoe Repair Shops, Clothing Alterations, Tailoring Services and Tattoo Parlors - One space for every 200 square feet, with a minimum of three (3) spaces.

Restaurants and Brew-Pubs with no live entertainment or dancing - One (1) space for every 200 square feet of floor area; or one (1) space for every four (4) indoor seats, plus one (1) for every eight (8) outdoor seats, whichever is greater.

Cocktail Lounges, Night Clubs, Banquet Facilities or Restaurants and Brew-Pubs with live entertainment or dancing - One (1) space for every 150 square feet; or one (1) space for every three (3) indoor seats plus one (1) for every six (6) outdoor seats, whichever is greater.

Retail Uses - For the first 10,000 square feet, one (1) space for every 400 square feet of floor area, with a minimum of three spaces; for all floor area exceeding the first 10,000 square feet, one (1) space for every 200 square feet. Combined uses located in a single building shall calculate required parking on the total square footage of the building and not the individual retail uses therein.

Self-Service Laundry - One (1) space for every six (6) machines (washers, dryers, and the like.)

Indoor Theaters - One (1) space for every five (5) seats.

Miniature Golf or Putting Course - One and one-half (1½) spaces per hole.

Arcades, with or without accessory billiard or pool tables - One (1) space for every 250 square feet of floor area.

Animal Grooming Facilities - One (1) space for every 200 square feet, with a minimum of three (3) spaces.

Country Inns – One (1) space per room or suite rented.

Combined Uses - Combined uses shall provide parking equal to the sum of the individual uses.

8-16(o) Special Provisions:

1. No building to be used principally as a single use or establishment shall exceed 40,000 square feet in floor area unless approved by the Planning Commission prior to December 10, 2013 for at least 40,000 square feet in size. No such structure may exceed 60,000 square feet in size, in any event.
2. Where dwelling units are provided and the Planning Commission has approved a final development plan, the required parking spaces may be reduced when specific permission is given by the Commission to reduce said required parking by not more than one percent (1%) for each one percent (1%) of additional useable open space that is provided over the minimum. Also, for every one percent (1%) of the dwelling units that will be provided as a mixed-income housing unit, the Commission may decrease the required parking by one percent (1%). In any case, the maximum parking reduction shall not exceed the minimum parking otherwise required in the zone by more than ten percent (10%) by only providing additional open space or only providing additional open space mixed-income housing; or twenty-five percent (25%) by using a combination of mixed-income housing and additional open space.
3. A form-based neighborhood business project may be approved by the Planning Commission on any site over one (1) acre in size. For any such project, a final development plan shall be approved by the Planning Commission prior to issuance of any building permit. The lot, yard, height and setback requirements will be those established by the Commission on the approved development plan, rather than those stated above. In addition to the development plan, an applicant seeking approval of a form-based neighborhood business project shall be required to submit an area character and context study prepared by an architect or urban design professional.

The study will document the architectural and urban design character of the area. It shall demonstrate, through the use of renderings, elevations and similar graphic materials, how the proposed project will enhance and complement the area's character. It will also show its integration with the surrounding neighborhood by using positive design features, such as supplemental landscaping; provision of public space and open space buffers; and improved pedestrian accommodations. These drawings shall be made a part of the Commission's approval, and building permits shall comply with the approved drawings. A form-based neighborhood business project shall not be subject to the square footage limitation of 8-16(o)(1) above.

8-17 DOWNTOWN BUSINESS (B-2) ZONE

8-17(a) Intent - This zone is intended to accommodate existing and future development in the Central Business District.

8-17(b) Principal Uses (Other uses substantially similar to those listed herein shall also be deemed permitted.)

1. The principal permitted uses in the B-1 zone.
2. Amusement enterprises, such as indoor billiard or pool halls; indoor theaters; bowling alleys; dance halls; skating rinks.
3. Restaurants, cocktail lounges and nightclubs, with entertainment, dancing or the sale of alcoholic beverages.
4. Establishments for the display, rental, or sale of automobiles, motorcycles, trucks not exceeding one and one-half (1½) tons, and boats limited to runabout boats; provided that the outdoor display or storage of vehicles shall conform to the requirements of Article 16.
5. Establishments engaged in blueprinting, printing, publishing and lithographing; interior decorating; upholstering; laundering, clothes cleaning and dyeing; clothing alterations and tailoring services.
6. Hotels and motels.
7. Passenger transportation terminals.
8. Any type of dwelling unit.
9. Wholesale establishments.
10. Minor automobile and truck repair.

11. Establishments primarily engaged in the sale of supplies and parts for vehicles and farm equipment.
12. Pawnshops.
13. Stadium and exhibition halls.
14. Telephone exchanges; radio and television studios.
15. Cable television system signal distribution centers and studios.
16. Athletic club facilities.
17. Adult arcades, massage parlors, adult book-stores, adult video stores, adult cabarets, adult dancing establishments, adult entertainment establishments, and sexual entertainment centers; provided that none shall be located within a 500-foot radius of any agricultural or residential zone, any elementary or secondary school, any park attended by persons under 18 years of age, or within a 1,000-foot radius of any other similarly regulated adult business.
18. Parking lots and structures, provided such use conforms to the conditions of Article 16.

8-17(c) Accessory Uses (Uses and structures which are customarily accessory, clearly incidental and subordinate to permitted uses.)

1. Storage, wholesaling, and warehousing.
2. Storage yards for delivery vehicles of a permitted use.
3. Sidewalk café, when accessory to any permitted restaurant.
4. Major automobile and truck repair, when accessory to an establishment primarily engaged in the sale of automobiles and trucks.
5. Satellite dish antennas, as further regulated in Article 15-8.
6. Micro-brewery, when accessory to a restaurant permitted herein; shall be located at least 100 feet from a residential zone, and shall be soundproofed to the maximum extent feasible by using existing technology, with noise or other emissions not creating a nuisance to the surrounding neighborhood.
7. Parking areas or structures.

8-17(d) Conditional Uses (Permitted only with Board of Adjustment approval.)

1. Helistops, provided such facilities conform to the requirements of all appropriate federal, state and local regulations.
2. Drive-through facilities for sale of goods or products or provision of services otherwise permitted herein.
3. Mining of non-metallic minerals, but only when the proposal complies with the requirements of the Mining/Quarrying Ordinance (Code of Ordinances #252-91) and the conditions and requirements as set forth therein. The Board of Adjustment shall specifically consider and be able to find:
 - a. That the proposed use will not constitute a public nuisance by creating excessive noise, odor, traffic, dust, or damage to the environment or surrounding properties;
 - b. That a reasonable degree of reclamation and proper drainage control is feasible; and
 - c. That the owner and/or applicant has not had a permit revoked or bond or other security forfeited for failure to comply with any Federal, State or local laws, regulations or conditions, including land reclamation, pertaining to the proposed use.
4. Adult arcades, adult bookstores, adult video stores, adult cabarets, adult dancing establishments, adult entertainment establishments, and sexual entertainment centers, except as permitted herein; provided none shall be located within a 500-foot radius of any elementary or secondary school, any park attended by persons under 18 years of age, or within a 1,000-foot radius of any other similarly regulated adult business.
5. Gasoline pumps available to the public without an employee on site, provided a plan is approved by the Board of Adjustment for periodic inspection of the site by an employee for the following purposes:
 - a. To check all operating equipment;
 - b. To check fire suppression system(s);
 - c. To check the condition of the fire alarm(s);
 - d. To check for indications of fuel leaks and spillage;
 - e. To remove trash from the site;
 - f. To monitor the general condition of the site.
6. Rehabilitation homes, when located closer than 500 feet from a residential zone, school for academic instruction or a child care center.
7. Temporary structures designed for use or occupancy for 61 to 180 days per 12-month period on a single property, calculating said period by cumulative consideration of the use of any and all such structures on a single property.
8. Circuses, provided all structures are located not less than 200 feet from any residential zone; and further provided that all structures for housing animals shall be 200 feet from any residential zone, residential use, school, hospital, nursing home

or rest home. A circus may not displace more than twenty-five percent (25%) of the minimum required parking for the site it occupies.

9. Automobile and vehicle refueling stations, provided such use conforms to all requirements of Article 16.
10. Ecotourism activities to include commercial hiking, bicycling, equine and zip line trails; tree canopy tours; canoeing and kayaking launch sites; fishing clubs; botanical gardens; nature preserves; and seasonal activities.

8-17(e) Prohibited Uses (All uses other than those listed as principal, accessory, or conditional uses or substantially similar to principal, accessory, or conditional uses shall be prohibited. The uses below are provided for illustration purposes and for the purpose of limiting permitted uses, and are not intended to be a total listing of all the uses that are prohibited.)

1. The prohibited uses in the B-1 zone, items 1 through 7, except as permitted herein.
2. Outdoor kennels or outdoor animal runs.
3. Establishments engaged in the display, rental, or repair of farm equipment, trucks exceeding one and one-half (1½) tons, and contractor's equipment.
4. The above- or below-ground storage of any flammable material in gaseous form, including compressed natural gas.
5. Hospitals.
6. Campgrounds and hunting clubs.
7. Farm tours, hayrides, corn mazes, outdoor rodeos, riding stables, horse shows, fishing lakes, hunting or trapping, sportsmen's farms, zoological gardens and classes related to agricultural products or skills.

Lot, Yard and Height Requirements (See Articles 3 and 15 for additional regulations.)

8-17(f) Minimum Lot Size - No limitation.

8-17(g) Minimum Lot Frontage - No limitation.

8-17(h) Minimum Front Yard - No limitation.

8-17(i) Minimum Each Side Yard - No limitation.

8-17(j) Minimum Rear Yard - No limitation.

8-17(k) Minimum Usable Open Space - No limitation (except that residential uses shall provide useable open space equal to not less than 10% of only those floors occupied by dwelling units).

8-17(l) Maximum Lot Coverage - No limitation.

8-17(m) Maximum Height of Building - No limitation.

8-17(n) Off-Street Parking (See Article 16 for additional parking regulations.)

Dwelling Units - No requirements, except for buildings with 25 or more dwelling units; then one (1) space for every 2,000 square feet of residential floor area.

All Other Permitted Uses - Off-street parking not required.

Off-street loading shall be as required in Article 16.

8-17(o) Special Provisions:

1. For any development within the Urban Renewal Project Area, all provisions of the Urban Renewal Plan shall take precedence over any provisions of this B-2 zone where such provisions are more restrictive than those set out in this zone.
2. For those floors of buildings containing dwelling units with windows for habitable rooms, there shall be provided a height-to-yard ratio of 3:1 for light and air. Public street right-of-way width may be used as part of this setback requirement, except that a minimum setback of five (5) feet from the property line, other than property lines adjoining street right-of-way, shall be required in any case. No setback shall be required for those floors containing non-residential uses or dwelling unit walls without windows.
3. Redevelopment of any site shall comply with the Downtown Streetscape Master Plan for Lexington, Kentucky.

8-18 DOWNTOWN FRAME BUSINESS (B-2A) ZONE

8-18(a) Intent - This zone is intended to accommodate existing and proposed development in the transitional "frame," which surrounds the downtown core area, by providing for comparable and compatible uses while anticipating the future expansion of the downtown core area.

8-18(b) Principal Uses (Other uses substantially similar to those listed herein shall also be deemed permitted.)

1. The principal permitted uses in the B-2 zone.

8-18(c) Accessory Uses (Uses and structures which are customarily accessory, clearly incidental and subordinate to permitted uses.)

1. The permitted accessory uses in the B-2 zone.

8-18(d) Conditional Uses (Permitted only with Board of Adjustment approval.)

1. The permitted conditional uses in the B-2 zone.

8-18(e) Prohibited Uses (All uses other than those listed as principal, accessory, or conditional uses or substantially similar to principal, accessory, or conditional uses shall be prohibited. The uses below are provided for illustration purposes and for the purpose of limiting permitted uses, and are not intended to be a total listing of all the uses that are prohibited.)

1. The prohibited uses in the B-2 zone.

Lot, Yard, and Height Requirements (See Articles 3 and 15 for additional regulations.)

8-18(f) Minimum Lot Size - No limitation.

8-18(g) Minimum Lot Frontage - No limitation.

8-18(h) Minimum Front Yard - 10 feet.

8-18(i) Minimum Each Side Yard - No limitation, except that side street side yard shall be ten (10) feet.

8-18(j) Minimum Rear Yard - No limitation.

8-18(k) Minimum Usable Open Space - No limitation, except that residential uses shall provide useable open space equal to not less than ten percent (10%) of only those floors occupied by dwelling units.

8-18(l) Maximum Lot Coverage - No limitation.

8-18(m) Maximum Height of Building - Three (3) stories, or 35 feet, except that buildings up to ten (10) stories shall be permitted if the Planning Commission approves a development plan; and for every story in excess of three (3) stories, one percent (1%) of the total lot area shall be added to the otherwise required front yard, or such area shall be provided as ground level open space on land adjoining the right-of-way.

8-18(n) Off-Street Parking (See Article 16 for additional parking regulations.)

Twenty-five percent (25%) of the least parking area required in any zone, other than the B-2 or B-2B zones which permit the principal or a similar use. Off-street loading and unloading areas shall be as required in Article 16.

8-18(o) Special Provisions:

2. Redevelopment of any site shall comply with the Downtown Streetscape Master Plan for Lexington, Kentucky.

8-19 LEXINGTON CENTER BUSINESS (B-2B) ZONE

8-19(a) Intent - This zone is intended to ensure compatible land uses, the preservation of existing attractions compatible with the Lexington Center, and the encouragement of new uses necessary to the proper development of the downtown area. The permitted land uses in the zone should have some logical relation to the Lexington Center and to the downtown core, should promote tourism, should promote the economic health of the community, should provide for an aesthetically pleasing environment, and should prevent the creation of influences adverse to the prospering of the Lexington Center and the downtown area.

8-19(b) Principal Uses (Other uses substantially similar to those listed herein shall also be deemed permitted.)

1. Civic Center and convention facilities.
2. Banks, credit agencies, security and commodity brokers and exchanges, credit institutions; savings and loan companies, holding and investment companies.
3. Offices and clinics.
4. Schools for academic instruction.
5. Libraries, museums, art galleries, and reading rooms.
6. Studios for work or teaching of fine arts, such as photography, music, drama, dance or theater.
7. Places of religious assembly.
8. Ticket and travel agencies.
9. Restaurants, cocktail lounges and nightclubs, including those serving alcoholic beverages and/or offering live entertainment, except as prohibited under Section 8-19(e).
10. Establishments for the retail sale of primarily new merchandise.
11. Beauty shops and barber shops.
12. Shoe repair, clothing alterations or tailoring services.
13. Retail sale of plant, nursery or greenhouse products, or agricultural produce.
14. Commercial farm markets and market gardens.
15. Hotels or motels.
16. Any type of residential use.
17. Antique shops.
18. Establishments for the display, rental or sale of automobiles, motorcycles, trucks not exceeding one and one-half (1½) tons, and boats limited to runabout boats; provided that the outdoor display or storage of vehicles shall conform to the requirements of Article 16.
19. Amusement enterprises, such as circuses; carnivals; horse racing or automobile racing, special events, festivals, and concerts provided such activity is operated on a temporary basis of a duration not exceeding two weeks.
20. Establishments engaged in blueprinting, printing, publishing, and lithography; interior decoration and upholstering; repair of household appliances.
21. Bookstores, except as prohibited under Section 8-19(e).
22. Indoor amusement enterprises, such as motion picture theaters, except as prohibited under Section 8-19(e); billiard or pool halls; bowling alleys; dance halls, skating rinks; and arcades.
23. Computer and data processing centers.
24. Telephone exchanges, radio and television studios.
25. Cable television system signal distribution centers and studios.
26. Private clubs, except as prohibited under Sections 8-19(e)(7, 8 and 9).
27. Kindergartens, nursery schools and child care centers for four (4) or more children. A fenced and screened play area shall be provided, which shall contain not less than 25 square feet per child.
28. Pawnshops which: (1) were in operation prior to August 31, 1990 and in compliance with the provisions of KRS 226.010 et seq. and Code of Ordinances, Sections 13-52 and 13-53; or (2) had on file with the Lexington-Fayette Urban County Government, prior to August 31, 1990, an application for a business license or certificate of occupancy.
29. Historic house museums.
30. Health clubs, athletic clubs and spas.

8-19(c) Accessory Uses (Uses and structures which are customarily accessory, clearly incidental and subordinate to permitted uses.)

1. Storage area for delivery vehicles of a permitted use.
2. Sidewalk café, when accessory to any permitted restaurant.
3. Major automobile and truck repair, when accessory to an establishment primarily engaged in the sale of automobiles and trucks.
4. Parking lots and parking structures, when accessory to principal permitted uses.
5. Satellite dish antennas, as further regulated by Article 15-8.
6. Micro-brewery, when accessory to a restaurant permitted herein; shall be located at least 100 feet from a residential zone, and shall be soundproofed to the maximum extent feasible by using existing technology, with noise or other emissions not creating a nuisance to the surrounding neighborhood.

8-19(d) Conditional Uses (Permitted only with Board of Adjustment approval.)

1. Automobile service stations at which only minor automobile and truck repair is performed, and provided such use conforms to all requirements of Article 16.
2. Automobile rental facilities; parking lots and parking structures, when not accessory to a principal permitted use, provided such uses conform to all requirements of Article 16.
3. Secondhand shops.
4. Self-service laundry or laundry pick-up stations, including clothes cleaning establishments of not more than forty (40) pounds capacity and using a closed-

- system process.
5. Helistops, provided such facilities conform to the requirements of all appropriate Federal, State and local regulations.
 6. Drive-through facilities for sale of goods or products or provision of services otherwise permitted herein.
 7. Recycling drop-off centers for aluminum; steel; plastic; glass; newspapers; cardboard and other paper products; oil and other household recyclable waste, provided that such an establishment shall be located at least 200 feet from any residential zone. Any appeal for a conditional use permit to operate a recycling drop-off center shall include as part of the application: Reasons for the location of the proposed use at a specific site, description of equipment to be used, physical arrangement, and operation of the proposed center. The Board of Adjustment shall consider the necessity of screening, if needed.
 8. Mining of non-metallic minerals, but only when the proposal complies with the requirements of the Mining/Quarrying Ordinance (Code of Ordinances #252-91) and the conditions and requirements as set forth therein. The Board of Adjustment shall specifically consider and be able to find:
 - a. That the proposed use will not constitute a public nuisance by creating excessive noise, odor, traffic, dust, or damage to the environment or surrounding properties;
 - b. That a reasonable degree of reclamation and proper drainage control is feasible; and
 - c. That the owner and/or applicant has not had a permit revoked or bond or other security forfeited for failure to comply with any Federal, State or local laws, regulations or conditions, including land reclamation, pertaining to the proposed use.
 9. Gasoline pumps available to the public without an employee on site, provided a plan is approved by the Board of Adjustment for periodic inspection of the site by an employee for the following purposes:
 - a. To check all operating equipment;
 - b. To check fire suppression system(s);
 - c. To check the condition of the fire alarm(s);
 - d. To check for indications of fuel leaks and spillage;
 - e. To remove trash from the site;
 - f. To monitor the general condition of the site.
 10. Temporary structures designed for use or occupancy for 61 to 180 days per 12-month period on a single property, calculating said period by cumulative consideration of the use of any and all such structures on a single property.
 11. Tattoo parlors.
 12. Ecotourism activities to include commercial hiking, bicycling, equine and zip line trails; tree canopy tours; canoeing and kayaking launch sites; fishing clubs; botanical gardens; nature preserves, and seasonal activities.

8-19(e) Prohibited Uses (All uses other than those listed as principal, accessory, or conditional uses shall be prohibited. The uses below are provided for illustration purposes and for the purpose of limiting permitted uses, and are not intended to be a total listing of all the uses that are prohibited.)

1. Establishments primarily engaged in agricultural equipment sales and services.
2. Warehouse, as well as storage uses, except as accessory uses herein.
3. Shops of special trade and general contractors, such as plumbing; heating; carpentry; masonry; plastering; painting; metal work; electrical; sign painting; tile, mosaic and terrazzo work; electroplating; drilling; excavating; wrecking, construction and paving. This is not intended to prohibit administrative offices of such.
4. Manufacturing, compounding, assembling, bottling, processing and packaging, and other industrial uses for sale or distribution other than as retail on the premises.
5. Truck terminals and freight yards.
6. Drive-in restaurants or drive-in theaters.
7. Establishments offering live entertainment in which a person is unclothed, or in such attire, costume or clothing as to expose to view any portion of the female breast below the top of the areola, the male or female genitalia, or the buttocks.
8. Establishments at which any employee is unclothed or in the attire, costume, or clothing described above, or is clothed in such a manner as to simulate the breast, genitalia, buttocks, or any portion thereof.
9. Establishments having as a substantial or significant portion of their stock in trade for sale, rent or display, pictures, books, periodicals, magazines, appliances and similar material which are distinguished or characterized by their emphasis on matter depicting, describing or relating to such sexual activities, as (a) depiction of human genitals in a state of sexual stimulation or arousal; (b) acts of human masturbation, sexual intercourse or sodomy, or (c) holding or other erotic touching of human genitals, pubic region, buttocks or breasts.
10. Animal kennels, hospitals, clinics, outdoor runways or pens, and animal grooming facilities.

11. The above- or below-ground storage of any flammable material in gaseous form, including compressed natural gas.
12. Pawnshops, except as permitted herein.
13. Campgrounds and hunting clubs.
14. Farm tours, hayrides, corn mazes, outdoor rodeos, riding stables, horse shows, fishing lakes, hunting or trapping, sportsmen's farms, zoological gardens and classes related to agricultural products or skills.

Lot, Yard, and Height Requirements (See Articles 3 and 15 for additional regulations.)

8-19(f) Minimum Lot Size - No limitation.

8-19(g) Minimum Lot Frontage - No limitation.

8-19(h) Minimum Front Yard - No limitation.

8-19(i) Minimum Each Side Yard - No limitation.

8-19(j) Minimum Rear Yard - No limitation.

8-19(k) Minimum Usable Open Space - No limitation, except that 10% shall be required for any residential area.

8-19(l) Maximum Lot Coverage - No limitation.

8-19(m) Maximum Height of Building - No limitation.

8-19(n) Off-Street Parking (See Article 16 for additional parking regulations.)

Dwelling Units - No requirements, except for buildings with 25 or more dwelling units: then one (1) space for every 2,000 square feet of residential floor area.

Hotels or Motels - One (1) space per suite, with a minimum of five (5) spaces.

8-19(o) Special Provisions:

1. For any development within the Urban Renewal Project Area, all provisions of the Urban Renewal Plan shall take precedence over any provisions of this B-2B zone where such provisions are more restrictive than those set in this zone.
2. Redevelopment of any site shall comply with the Downtown Streetscape Master Plan for Lexington, Kentucky.

8-20 HIGHWAY SERVICE BUSINESS (B-3) ZONE

8-20(a) Intent - This zone is intended to provide for retail and other uses, which are necessary to the economic vitality of the community but may be inappropriate in other zones. The Comprehensive Plan should be used to determine the locations for this zone. Special consideration should be given to the relationship of the uses in the zone to the surrounding land uses and to the adequacy of the street system to serve the traffic needs.

8-20(b) Principal Uses (Other uses substantially similar to those listed herein shall also be deemed permitted.)

1. Establishments and lots for the display, rental, sale, service, and minor repair of farm equipment, contractor equipment, automobiles, motorcycles, trucks, boats, travel trailers, mobile homes, or supplies for such items.
2. Automobile service stations, subject to the conditions of Article 16.
3. Restaurants, cocktail lounges and nightclubs, with entertainment, dancing, and/or sale of alcoholic beverages.
4. Car washing establishments, provided that surface water from such use shall not drain onto adjacent property or over a public sidewalk, and that adequate on-site storage lanes and parking facilities shall be provided so that no public way shall be used for such purposes.
5. Motel or hotel.
6. Indoor amusements, such as billiard or pool halls; dancing halls; skating rinks; miniature golf or putting courses; theaters or bowling alleys.
7. Self-service laundry, laundry pick-up station, or clothes cleaning establishments of not more than forty (40) pounds capacity and using a closed-system process.
8. Garden centers.
9. Kennels, animal hospitals or clinics, including offices of veterinarians, provided that such structures or uses, not including accessory parking areas, shall be at least 100 feet from any residential zone.
10. Drive-in restaurants, provided that all outside food service areas shall be at least

- 100 feet from any residential zone.
11. Establishments for the retail sale of merchandise as permitted in the B-1 zone, unless prohibited by Section 8-20(e).
 12. Minor automobile and truck repair.
 13. Banks, credit agencies, security and commodity brokers and exchanges, credit institutions, savings and loan companies, holding and investment companies.
 14. Beauty shops and barber shops.
 15. Shoe repair, clothing alteration, tailoring services and tattoo parlors.
 16. Carnivals, special events, festivals and concerts on a temporary basis, and upon issuance of a permit by the Divisions of Planning and of Building Inspection, which may restrict the permit in terms of time, parking, access or in other ways to protect public health, safety, or welfare; or deny such if public health, safety or welfare are adversely affected. A carnival, special event, festival, or concert may not displace more than twenty-five percent (25%) of the minimum required parking for the site it occupies.
 17. Offices and medical clinics.
 18. Taxidermy establishments.
 19. Quick copy services utilizing xerographic or similar processes, but not utilizing offset printing methods.
 20. Business colleges, technical or trade schools or institutions.
 21. Schools for academic instruction.
 22. Kindergartens, nursery schools and child care centers, where enrollment of children is sponsored and licensed by established places of religious assembly and non-profit community-based groups, and/or where enrollment may be limited to children of employees and staff of an office, business or commercial establishment which is located on or abutting the same lot as the proposed child care facility. A fenced and screened play area shall be provided in an area, located a minimum of ten (10) feet from a collector or arterial street, and shall contain not less than 25 square feet per child.
 23. Pawnshops which: (1) were in operation prior to August 31, 1990 and in compliance with the provisions of KRS 226.010 et seq. and Code of Ordinances, Sections 13-52 and 13-53; or (2) had on file with the Lexington-Fayette Urban County Government, prior to August 31, 1990, an application for a business license or certificate of occupancy.
 24. Indoor athletic clubs and recreational facilities.
 25. Parking lots and structures.
 26. Adult arcades, massage parlors, adult bookstores, adult video stores, adult cabarets, adult dancing establishments, adult entertainment establishments, and sexual entertainment centers, provided that none shall be located within a 500-foot radius of any agricultural or residential zone, any elementary or secondary school, any park attended by persons under 18 years of age, or within a 1,000-foot radius of any other similarly regulated adult business.
 27. Commissaries for preparation of food for restaurant use.
 28. Retail sale of automotive parts with storage and distribution of inventory to other local establishments under the same ownership, when such use is at least 200 feet from a residential zone.
 29. Automobile and vehicle refueling stations, provided such uses conform to all requirements of Article 16.
 30. Commercial farm markets and market gardens.

8-20(c) Accessory Uses (Uses and structures which are customarily accessory, clearly incidental and subordinate to permitted uses.)

1. Wholesale, warehouse, and storage facilities.
2. Parking areas and structures.
3. Swimming pools.
4. Newsstands and retail shops when accessory to a motel or hotel, provided there are no exterior entrances or signs visible from outside the structure in which they are located.
5. Not more than one (1) dwelling unit for owners, operators, or employees of a permitted use, provided that such dwelling unit shall be a part of and located above or to the rear of such permitted use.
6. Major automobile and truck repair, when accessory to an establishment primarily engaged in the sale of automobiles and trucks.
7. Drive-through facilities for sale of goods or products or provision of services otherwise permitted herein.
8. Satellite dish antennas, as further regulated by Article 15-8.
9. Pawnshops which are accessory to an establishment primarily engaged in the retail sale of jewelry. Not less than fifty percent (50%) of the gross revenue of such establishments shall come from the retail sale of jewelry.
10. Micro-brewery, when accessory to a restaurant permitted herein; and shall be located at least 100 feet from a residential zone and shall be soundproofed to the maximum extent feasible by using existing technology, with noise or other emissions not creating a nuisance to the surrounding neighborhood.

11. Retail sale of liquid propane (limited to 20-lb. containers), when accessory to the retail sale of merchandise or an automobile service station permitted under Article 8-20(b).

8-20(d) Conditional Uses (Permitted only with Board of Adjustment approval.) Required conditions for any conditional use permitted herein shall be as follows:

- Any conditional use shall be located, in relationship to the arterial roadway system, so that the conditional use has a minimal effect on the adjoining streets and the surrounding uses.
 - Any outdoor theater screen or illuminated scoreboard or other similar surface shall not be visible from any street for a distance of 1,000 feet from said structure.
 - Entrances of ingress or egress, acceleration lanes, and deceleration lanes shall be provided in conformance with requirements as established by the Urban County Traffic Engineer.
1. Outdoor athletic facilities that would be compatible in a Highway Service Business (B-3) zone, such as a football stadium; tennis courts; a soccer or polo field, and a baseball field.
 2. Amusement parks, fairgrounds, or horse racing tracks, if all buildings are located not less than 200 feet from any residential zone; and further provided that all buildings for housing animals shall be 200 feet from any residential zone, residence, school, place of religious assembly, hospital, nursing home, or personal care facility.
 3. Outdoor theaters, provided that all facilities, other than highway access drives, are not less than 1,000 feet from any residential zone, residence, school, place of religious assembly, hospital, nursing home, or personal care facility; and further provided that a vehicle storage area equal to thirty percent (30%) of the capacity of the theater be provided between the highway and theater ticket gate.
 4. Outdoor recreational facilities, including go-cart tracks; archery courts; skate-board and roller skating tracks; trampoline centers; rifle and other fire-arm ranges; swimming pools; water slides and other water-related recreational facilities, and other similar uses.
 5. Passenger transportation terminals.
 6. Pawnshops, except as permitted herein.
 7. Mining of non-metallic minerals, but only when the proposal complies with the requirements of the Mining/Quarrying Ordinance (Code of Ordinances #252-91) and the conditions and requirements as set forth therein. The Board of Adjustment shall specifically consider and be able to find:
 - a. That the proposed use will not constitute a public nuisance by creating excessive noise, odor, traffic, dust, or damage to the environment or surrounding properties;
 - b. That a reasonable degree of reclamation and proper drainage control is feasible; and
 - c. That the owner and/or applicant has not had a permit revoked or bond or other security forfeited for failure to comply with any Federal, State or local laws, regulations or conditions, including land reclamation, pertaining to the proposed use.
 8. Adult arcades, adult bookstores, adult video stores, adult cabarets, adult dancing establishments, adult entertainment establishments, and sexual entertainment centers, except as permitted herein, provided none shall be located within a 500-foot radius of any elementary or secondary school, any park attended by persons under 18 years of age, or within a 1,000-foot radius of any other similarly regulated adult business.
 9. Places of religious assembly and Sunday schools.
 10. The above- or below-ground storage of any flammable material in gaseous form, including compressed natural gas; except as permitted herein, or except in conformance with the Kentucky Building Code and all applicable fire safety codes. Except in association with an automobile and vehicle refueling station, total above-ground storage of gas is limited to 600 square feet. There may be no filling or re-filling of gas containers in this zone.
 11. Temporary structures designed for use or occupancy for 61 to 180 days per 12-month period on a single property, calculating said period by cumulative consideration of the use of any and all such structures on a single property.
 12. Circuses, provided all structures are located not less than 200 feet from any residential zone; and further provided that all structures for housing animals shall be 200 feet from any residential zone, residential use, school, hospital, nursing home or rest home. A circus may not displace more than twenty-five percent (25%) of the minimum required parking for the site it occupies.
 13. Ecotourism activities to include campgrounds; commercial hiking, bicycling, equine and zip line trails; tree canopy trails; canoeing and kayaking launch sites; fishing and hunting clubs; botanical gardens; nature preserves; and seasonal activities.

8-20(e) Prohibited Uses (All uses other than those listed as principal, accessory, or conditional uses or substantially similar to principal, accessory, or conditional uses shall be prohibited. The uses below are provided for illustration purposes and for the purpose of limiting permitted uses, and are not intended to be a total listing of all the uses that are prohibited.)

1. The prohibited uses in the B-1 zone, items 1 through 5.
 2. Automobile, truck, ATV, motorcycle, bicycle motocross, or other vehicle or bicycle race tracks.
 3. Establishments for cleaning, dyeing, and the like, except as permitted herein.
 4. Dwellings, except as accessory uses herein.
 5. Major automobile and truck repair, except as permitted herein.
 6. Boarding houses.
 7. Outdoor retail sale of merchandise, unless accessory to a permanent retail sales establishment that conducts most of its activities within a completely enclosed building or group of buildings.
 8. The above- or below-ground storage of any flammable material in gaseous form, including compressed natural gas, except as permitted herein.
 9. Hospitals.
 10. Museums, including historic house museums.
 11. Farm tours, hayrides, corn mazes, outdoor rodeos, riding stables, horse shows, fishing lakes, hunting or trapping, sportsmen's farms, and zoological gardens.
- Lot, Yard, and Height Requirements (See Articles 3 and 15 for additional regulations.)

8-20(f) Minimum Lot Size - No limitation.

8-20(g) Minimum Lot Frontage - 40'.

8-20(h) Minimum Front Yard - 20'.

8-20(i) Minimum Each Side Yard - No limitation, except as provided in Section 8-20(o).

8-20(j) Minimum Rear Yard - No limitation, except as provided in Section 8-20(o).

8-20(k) Minimum Useable Open Space - No limitation.

8-20(l) Maximum Lot Coverage - No limitation.

8-20(m) Maximum Height of Building - 75', except where a side or rear yard abuts a Professional Office or a Residential zone, then a 3:1 height to yard ratio.

8-20(n) Off-Street Parking (See Article 16 for additional parking regulations.)

As for B-1.

Establishments for display, rental, sale, service or repair of farm implements, contractor equipment, automobiles, motorcycles, boats, travel trailers, mobile homes, or supplies for such items - One (1) space for every 600 square feet of floor area, with a minimum of five (5) spaces.

Car Washing Establishments - Two (2) spaces for each stall, plus one (1) space for each vacuum unit.

Motels and Hotels - One (1) space per suite with a minimum of five (5) spaces.

Bowling Alleys - Four (4) spaces per alley; however, snack bars and food service provided primarily to patrons shall not require additional parking.

Offices of Veterinarians, Animal Hospitals or Clinics, and Kennels - One (1) space for every 200 square feet of floor area.

Billiard or Pool Halls, Arcades, Dance Halls, Indoor Athletic Facilities, and other amusement places without fixed seats - One (1) space for every 100 square feet of floor area, plus one space for every three (3) employees.

Skating Rinks - One (1) space for each 400 square feet of floor area, plus one (1) space for every employee.

Theaters - One (1) space for every five (5) seats.

Indoor and Outdoor Athletic Facilities, Horse Race Tracks, and other amusement places with fixed seats - One (1) space for every five (5) seats, plus one (1) space for every three (3) employees.

Miniature Golf or Putting Courses - One and one-half (1½) spaces per hole.

Garden Centers - One (1) space for every 400 square feet of floor area; plus one (1) space for each employee, with a minimum of five (5) spaces.

Adult Arcades and Massage Parlors - As for retail uses in the B-1 zone (with a minimum of three (3) spaces) or one (1) space for every five (5) seats, whichever is greater.

Adult Bookstores or Adult Video Stores - As for retail uses in the B-1 zone (with a minimum of three (3) spaces.)

Adult Cabarets, Adult Dancing Establishments, Adult Entertainment Establishments, and Sexual Entertainment Centers - As for retail uses in the B-1 zone (with a minimum of three (3) spaces), or one (1) space for every three (3) seats, whichever is greater.

Other Recreational Facilities or Ecotourism activities not otherwise stated herein – Five (5) spaces, plus one (1) space for each employee for each separate use.

Conditional Uses - Parking requirements for conditional uses shall be minimum requirements; the Board of Adjustment may require additional parking, as needed.

Combinations - Combined uses shall provide parking equal to the sum of individual requirements.

8-20(o) Special Provisions

1. Landscape buffer areas shall be required as set forth in Article 18.
2. No building to be used principally as a single store selling food, produce, grocery items or general merchandise shall exceed 80,000 square feet in floor area unless:
 - a) approved by the Planning Commission prior to April 27, 2000 for a larger area, or
 - b) the building is designed to meet the design guidelines for “big-box” retail establishments (Article 12-8), unless specific guidelines are waived by the Planning Commission through its approval of a final development plan.

8-21 WHOLESALE AND WAREHOUSE BUSINESS (B-4) ZONE

8-21(a) Intent - This zone is intended primarily for wholesaling, warehousing, storage operations and establishments whose activity is of the same general character as the above. To a lesser extent, this zone is also intended to provide for the mixture of professional offices and warehouses that promote reuse and redevelopment of older warehouses, allowing businesses to combine their entire operation in one building, as recommended for the Office/ Warehouse land use category in the Comprehensive Plan. This zone is also intended to encourage the adaptive reuse of older structures in or adjoining the Infill and Redevelopment Area to promote revitalization of these buildings, and the flexible use of sites outside of the Infill and Redevelopment Area. The Comprehensive Plan should be used to determine the appropriate locations for this zone. Consideration should be given to the relationship of this zone to the surrounding land uses and the adequacy of the street system to serve the anticipated traffic needs.

8-21(b) Principal Uses (Other uses substantially similar to those listed herein shall also be deemed permitted.)

1. Wholesale establishment, wholesale establishment with warehouses, storage, and warehousing.
2. Shops of special trade and general contractors, such as plumbing; heating; carpentry; masonry; painting; plastering; metal work; printing; publishing; lithographing; engraving; electrical; major automobile and truck repairing; sign painting; upholstering; tile, mosaic and terrazzo work; electroplating; interior decorating; catering.
3. Laundry (excluding self-service laundry), clothes cleaning or dyeing shop.
4. Ice plant.
5. Tire re-treading and recapping.
6. Parking lots and structures.
7. Machine shop.
8. Kennels, animal hospitals or clinics, provided that such structures or areas used, not including accessory parking areas, shall be at least 100 feet from any residential zone.
9. Offices of purchasers, processors and handlers of agricultural products, limited to administrative uses only.
10. Sales of feed, grain, or other agricultural supplies.
11. Garden centers.
12. Establishments and lots for the display, rental, sale, and repair of farm equipment; contractor equipment; automobiles, trucks, mobile homes; recreational vehicles, such as mini-bikes, motorcycles, bicycles; boats or supplies for such items.
13. Truck terminals and freight yards.

14. Automobile service stations, subject to the conditions of Article 16.
15. Major or minor automobile and truck repair.
16. Establishments for the display and sale of precut, prefabricated, or shell homes.
17. Carnivals on a temporary basis, and upon issuance of a permit by the Divisions of Planning and Building Inspection, which may restrict the permit in terms of time, parking, access or other ways to protect public health, safety, or welfare; or deny such if public health, safety or welfare are adversely affected. A carnival may not displace more than twenty-five percent (25%) of the minimum required parking for the site it occupies.
18. Retail sale of building materials and lumber.
19. Pawnshops which (1) were in operation prior to August 31, 1990 and in compliance with the provisions of KRS 226.010 et seq. and Code of Ordinances, Sections 13-52 and 13-53; or (2) had on file with the Lexington-Fayette Urban County Government, prior to August 31, 1990, an application for a business license or certificate of occupancy.
20. Mail order business.
21. Office uses, limited to a maximum square footage of 60% of the floor area in the building in which the use is located.
22. Office/warehouse mixed-use project, as further regulated by Article 8-21(o)(3).
23. Adaptive Reuse Projects, as further regulated in 8-21(o)4.
24. Shredding, sorting and baling of paper scrap and storage of waste paper, when wholly conducted in a completely enclosed building.
25. Automobile and vehicle refueling stations, provided such uses conform to all requirements of Article 16.
26. Flex Space Projects, as further regulated in 8-21(o)5.
27. Indoor recreational activities, including, but not limited to, indoor tennis courts; skating rinks; athletic club facilities and bowling alleys. Also included would be any outdoor recreational facilities that are customarily accessory, clearly incidental and subordinate to such indoor recreational activities.

8-21(c) Accessory Uses (Uses and structures which are customarily accessory, clearly incidental and subordinate to permitted uses.

1. Parking areas and structures, and loading areas.
2. Financial and insurance offices, the principal activities of which are oriented towards agricultural loans and farm insurance.
3. Laundry pick-up station, when accessory to a laundry or dry-cleaning establishment.
4. Retail sale of hardware-related items, when accessory to the sale of building materials and/or lumber.
5. Satellite dish antennas, as further regulated by Article 15-8.
6. Sale of manufactured products, goods, merchandise and finished products related or incidental to the principal use, provided that the area set aside for sales of these related or incidental items does not constitute more than 30% of the total floor and storage area.
7. The retail sale of groceries; dairy products; bakery goods; meat; beer; health and beauty items; stationery; and similar convenience-type merchandise, when accessory to an automobile service station.
8. Beauty salons where accessory to an athletic club facility, provided that the area of the salon shall not constitute more than 10% of the total floor area, that the salon has no separate external entrance, nor separate business signage.
9. Facilities for serving food only for employees and visitors; having no direct access to the exterior, and having no signs visible from the exterior of the building. Mobile food unit vendors may also serve this purpose, and be parked outside of a building to serve employees and visitors, provided that the requirements of Section 15-11 of the Code of Ordinances are met.
10. Retail sale of liquid propane (limited to 20-lb. containers), when accessory to the retail sale of building materials and lumber permitted under Article 8-21(b)(18).

8-21(d) Conditional Uses (Permitted only with Board of Adjustment approval.)

1. Mining of non-metallic minerals, but only when the proposal complies with the requirements of the Mining/Quarrying Ordinance (Code of Ordinances #252-91) and the conditions and requirements as set forth therein. The Board of Adjustment shall specifically consider and be able to find:
 - a. That the proposed use will not constitute a public nuisance by creating excessive noise, odor, traffic, dust, or damage to the environment or surrounding properties;
 - b. That a reasonable degree of reclamation and proper drainage control is feasible; and
 - c. That the owner and/or applicant has not had a permit revoked or bond or other security forfeited for failure to comply with any Federal, State or local laws, regulations or conditions, including land reclamation, pertaining to the proposed use.

2. Places of religious assembly, Sunday schools, and schools for academic instruction, when affiliated with a place of religious assembly or a religious entity, except as provided as part of an adaptive reuse project.
3. Retail sale (except as provided as part of an adaptive reuse project) of furniture and household-related items, such as antiques; fabrics; fixtures; furnishings; glassware and china; when accessory to its storage, refinishing, repairing or upholstery on the same premises.
4. Temporary structures designed for use or occupancy for 61 to 180 days per 12-month period on a single property, calculating said period by cumulative consideration of the use of any and all such structures on a single property.
5. Circuses, provided all structures are located not less than 200 feet from any residential zone; and further provided that all structures for housing animals shall be 200 feet from any residential zone, residential use, school, hospital, nursing home or rest home. A circus may not displace more than twenty-five percent (25%) of the minimum required parking for the site it occupies.
6. Ecotourism activities to include campgrounds; commercial hiking, bicycling, equine and zip line trails; tree canopy trails; canoeing and kayaking launch sites; recreational outfitters; fishing and hunting clubs; botanical gardens; nature preserves; and seasonal activities, including associated gift shops as an accessory use.
7. Market gardens, except as provided as part of an adaptive reuse project.

8-21(e) Prohibited Uses (All uses other than those listed as principal, accessory, or conditional uses or substantially similar to principal, accessory, or conditional uses shall be prohibited. The uses below are provided for illustration purposes and for the purpose of limiting permitted uses, and are not intended to be a total listing of all the uses that are prohibited.)

1. Heavy manufacturing, heavy assembling, compounding, packaging, bottling, processing, and other industrial uses, except as permitted herein.
2. Storage of commodities, the storage of which is permitted for the first time in the industrial zones.
3. Amusement enterprises, such as indoor theaters; drive-in theaters; horse race tracks; pool halls; billiard halls; dancing halls and amusement parks.
4. Retail sales and offices, except as permitted herein.
5. Motels and hotels; boarding houses.
6. Personal service establishments, except as permitted herein.
7. Dwellings, except as permitted in an office/ warehouse project herein.
8. Schools and colleges for academic instruction, except as permitted herein.
9. Restaurants, cocktail lounges, and nightclubs, except as permitted herein.
10. Car washing establishments.
11. Refuse dumps, landfills, transfer stations, and incinerators.
12. The above- or below-ground storage of any flammable material in gaseous form, including compressed natural gas, except in association with an automobile and vehicle refueling station.
13. Pawnshops, except as permitted herein.
14. Special events, parties, festivals and concerts.
15. Museums, including historic house museums.
16. Farm tours, hayrides, corn mazes, commercial far markets, outdoor rodeos, riding stables, horse shows, fishing lakes, hunting and trapping, sportsmen's farms, zoological gardens, value-added product sales, and classes related to agricultural products or sales.

Lot, Yard, and Height Requirements (See Articles 3 and 15 for additional regulations.)

8-21(f) Minimum Lot Size - No limitation.

8-21(g) Minimum Lot Frontage - No limitation.

8-21(h) Minimum Front Yard - No limitation, except as provided in Section 8-21(o).

8-21(i) Minimum Each Side Yard - No limitation, except as provided in Section 8-21(o).

8-21(j) Minimum Rear Yard - No limitation, except as provided in Section 8-21(o).

8-21(k) Minimum Useable Open Space - No limitation.

8-21(l) Maximum Lot Coverage - No limitation.

8-21(m) Maximum Height of Building - 75', except when a side or rear yard abuts a Professional Office or a Residential zone, then a 3:1 height-to-yard ratio.

8-21(n) Off-Street Parking - (See Article 16 for additional parking regulations.)

Wholesale business, warehousing, storage; Establishments for special trade and general contractors; Machine shops; Sale of feed, grain or other agricultural supplies; Garden centers; and Establishments for the rental, sale, service and repair of farm equipment, contractor equipment, trucks, travel trailers and mobile homes - One (1) space for every 600 square feet of floor area, with a minimum of five (5) spaces.

Tire re-treading or recapping; Truck terminals and Ice plants - One (1) space for each two (2) employees on a maximum working shift; plus one (1) space for each vehicle owned or operated by the use, with a minimum of five (5) spaces total.

Offices, as permitted herein; Animal Hospitals or Clinics; Laundry, clothes cleaning or dyeing shop - One (1) space for every 200 square feet of floor area, with a minimum of five (5) spaces.

Animal Grooming Facilities - One (1) space for every 200 square feet, with a minimum of three (3) spaces.

Kennels - One (1) space for every 600 square feet of floor area; plus one (1) space per two (2) employees on the maximum shift, with a minimum of five (5) spaces.

Office/Warehouse Mixed-Use Project - One (1) space for every 500 square feet of parking floor area, with a minimum of five (5) spaces.

Skating Rinks - One (1) space for every 400 square feet of floor area, plus one (1) space for each employee.

Bowling Alleys - Four (4) spaces per alley; however, snack bars and food service provided primarily to patrons shall not require additional parking.

Tennis Courts and other similar indoor recreational uses - One (1) space for every two (2) participants, plus one (1) space for every three (3) spectator seats, plus one (1) space for each employee.

Mail Order Business - One (1) for every two (2) employees on a maximum working shift, with a minimum of five (5) spaces; plus one (1) space for every 400 square feet of accessory retail sales area.

Retail Sales, Bulk Merchandise - One (1) space for every 250 square feet of floor area.

Other Recreational Facilities or Ecotourism activities not otherwise stated herein – Five (5) spaces, plus one (1) for each employee for each separate use.

Conditional Uses - Parking requirements for conditional uses are minimum requirements; the Board of Adjustment may require additional parking, as needed.

Combinations - Combined uses shall provide parking equal to the sum of individual requirements.

8-21(o) Special Provisions:

1. All buildings and structures shall be at least 100 feet from any residential zone, unless the portion within that distance has no opening except stationary windows and doors that are designed and intended solely for pedestrian access.
2. Landscape buffer areas shall be required as set forth in Article 18.
3. An Office/Warehouse mixed-use project may be permitted by the Planning Commission upon the approval of a final development plan, as provided in Article 21 of the Zoning Ordinance, and subject to the following requirements:

In addition to the uses permitted in Article 8-21(b), the following uses shall also be permitted in an Office/Warehouse Project:

As principal permitted uses:

- a. Offices, laboratories and data processing centers, limited to a maximum of 75% of the floor area of the building or project. This square footage limitation shall not apply if the project is located within the defined Infill and Redevelopment Area.

As accessory uses:

- a. Drive-through facilities for the provision of services allowed in an Office/Warehouse mixed-use project;
 - b. Dwelling units for on-site security personnel.
4. Adaptive Reuse Projects may be permitted by the Planning Commission upon the approval of a final development plan, subject to the following requirements:
 - a. The property must be located in or adjacent to, or across a public right-of-way

- from, the defined Infill and Redevelopment Area. The area of the Project will be defined by the development plan and may include noncontiguous properties that can function together as an interrelated development.
- b. The Project must include at least one existing building that will be adaptively re-used as a principal structure.
 - c. The applicant shall provide documentation demonstrating that the Project meets at least three of the following criteria:
 1. It will incorporate sustainable features such as LEED Certification, "green" infrastructure, alternative energy or other innovative design or system.
 2. It will include a structure individually listed on the National Register of Historic Places or is determined to be eligible for such listing; is determined to contribute to the significance of a National Register Historic District or is in an area that meets the requirements of a National Historic District; is individually listed on a state inventory of historic places; is located within an Historic District (H-1) overlay zone; or is over 50 years old.
 3. It is in a district that has applied for, or has obtained, special funding such as tax increment financing or similar government incentives.
 4. It will provide residential housing, at least 10% of which will be set aside for affordable housing.
 5. It will provide a high degree of innovative accommodation for non-vehicular transportation.
 6. It is in an area specified in the Comprehensive Plan for adaptive reuse or revitalization.
 7. It is within an area that is a brownfields recovery site.
 8. Public art is provided by the development that will be publicly displayed in an accessible unpaid area and is visible from the adjacent street level. This is not to include a business logo or other type of advertisement.
 9. It has a single building of over 30,000 square feet that is over 50 years old, or a total project of over 80,000 square feet with at least two adaptive reuse buildings over 50 years old. A single building may not be used to meet both criteria #2 and #9.
 - d. Principal uses in Adaptive Reuse Projects:
 1. Any of the principal uses permitted in the underlying zone.
 2. Schools; libraries; museums; art galleries; studios for work or teaching of fine arts, metal work, photography, dance, drama or theater; theaters, including movie theaters and other indoor amusements, except as prohibited under Section 8-19(e), including billiard or pool halls, bowling alleys, dance halls, skating rinks and arcades.
 3. Community centers, churches and private clubs.
 4. Restaurants, with or without outdoor seating and with or without live entertainment.
 5. Establishments for the retail sale of food, dairy, bakery, meat, beer, liquor, wine and other food products; the retail sale of merchandise, including new or used clothing and books, gifts, toys, antiques, furnishings, housewares, jewelry, electronics and similar items.
 6. Pharmacies, provided that they are within a structure containing other uses and do not occupy a separate building.
 7. Banquet facilities or private clubs with live entertainment, brew-pubs, bars, cocktail lounges and nightclubs.
 8. Offices, banks or clinics.
 9. Hotels or motels.
 10. Beauty shops, barber shops, shoe repair, dressmaking or tailoring.
 11. Quick copy services not using offset printing methods.
 12. Residences of any kind.
 13. Health clubs, athletic clubs and spas.
 14. Parking lots and structures.
 15. Retail sales of plant, nursery or greenhouse products or agricultural products, produce or goods, including market gardens.
 16. Kindergartens, nursery schools and child care centers for four (4) or more children. A fenced and screened play area shall be provided, which shall contain at least 25 square feet per child.
 17. Indoor or outdoor amusement or entertainment enterprises such as circuses, carnivals, rodeos, horse shows or automobile shows; provided such activity is operated on a temporary basis, not to exceed two weeks.
 18. Passenger transportation terminals.
 - e. Accessory uses that are clearly incidental and subordinate to the principal uses are permitted.
 - f. Conditional uses:
 1. Drive-through facilities.
 - g. Prohibited uses:
 1. All adult uses, as listed in Sections 8-16(e)(14 through 17).
 - h. Parking
 1. Dwelling Units – One (1) space for every two (2) units.
 2. Non-Residential Uses – Fifty percent (50%) of the least parking required in

any zone other than the B-2, B-2A or B-2B zone, which permits the use or a similar use.

3. Allowable Reductions in Parking:
 - a. Bicycle Reduction – Sites having fifty (50) or more parking spaces may reduce the total minimum automobile parking space requirement by one (1) parking space for every one (1) bicycle space provided in a permanent, constructed bicycle locker. The maximum reduction of required parking spaces, based on provision of bicycle parking, shall not be reduced less than five percent (5%) of the otherwise required amount.
 - b. Allowable Transit Stop Reductions – Sites located within 300 feet of a transit stop with a shelter may be allowed a ten percent (10%) reduction of the minimum required parking. Sites located within 300 feet of a transit stop without a shelter shall be allowed a five percent (5%) reduction of the minimum required parking. If the site is located within 300 feet of more than one transit stop, the maximum reduction allowed will be ten percent (10%) for this specific parking reduction.
 - c. Reductions in required off-street parking for transit stops and bicycle lockers may be combined for the same property, but in any event may not reduce the total amount of required off-street parking by more than 15%.
 - i. Signage – Shall be as permitted under Article 17-7(o) for an MU-2 zone.
 - j. Lot and Yard Requirements - No minimum.
 - k. Height - No maximum height for adaptive reuse of existing buildings. New buildings shall not be more than 12 feet taller than the tallest structure that is being adaptively re-used, or 48 feet, whichever is greater.
 - l. The applicant shall submit a compliance statement with the development plan that specifies how the project will further the Goals and Objectives and other elements of the Comprehensive Plan.
 - m. Prior to holding a hearing on the development plan, the applicant shall post a sign, with dimensions set out in Article 23B-5(b), at a visible location on the property at least 14 days prior to the hearing, informing the public of the location, date and time of the hearing. Evidence of the sign having been posted shall be submitted to the Planning Commission at the hearing.
 - n. The Planning Commission shall have the power to approve, modify or disapprove the development plan, as set out in Article 21. In addition, if the Planning Commission approves the development plan, it must adopt a finding that the development plan furthers the Goals and Objectives or other elements of the Comprehensive Plan.
5. Flex Space Projects may be permitted by the Planning Commission upon the approval of a final development plan, subject to the following requirements:
 - a. The site must be located outside of the defined Infill and Redevelopment Area.
 - b. Principal uses in Flex Space Projects shall include:
 1. Any of the principal uses permitted in the underlying zone.
 2. Schools; libraries; museums; art galleries; studios for work or teaching of fine arts, metal work, photography, dance, drama or theater.
 3. Places of religious assembly and private clubs.
 4. Establishments for the retail sale of merchandise, food and food products, if under 20,000 square feet in area.
 5. Restaurants, if under 4,000 square feet in area.
 6. Offices.
 7. Health clubs, athletic clubs and spas.
 8. Market gardens.
 - c. Accessory uses that are clearly incidental and subordinate to the principal uses.
 - d. Conditional uses:
 1. Drive-through facilities.
 - e. Prohibited uses:
 1. All adult uses, as listed in Section 8-16(e)(14 through 17).
 - f. Parking:
 1. Restaurants - as set forth in the B-1 zone.
 2. All other uses - One (1) space per 600 square feet.
 - g. Signage, lot, yard and height requirements shall be as set forth in the underlying zone.
 - h. The Planning Commission shall, with the approval of any development plan, consider the following locational and compatibility factors:
 1. A Flex Space Project shall generally not be located on a major arterial. If the Project is located on a major arterial, the applicant shall address whether additional parking needs to be provided to accommodate “impulse” customers.
 2. The Project shall generally be located in an area of mixed uses and zones.
 3. The Project shall generally be located in an area that has historically had a mixture of retail and wholesaling land uses.
 4. The Project shall generally be located in a B-4 or I-1 area in which, due to small lot size, adjacent uses, or the nature of the roadway system, it would not be appropriate to construct larger B-4 or I-1 uses, such as truck terminals, manufacturing facilities or large warehousing facilities.
 5. The property is the site of an existing building with substantial lot coverage

- that does not allow substantial expansion of the building or parking facilities.
6. The Project shall generally not be located in a block front that contains residential zoning.

8-22 LIGHT INDUSTRIAL (I-1) ZONE

8-22(a) Intent - This zone is intended for manufacturing, industrial and related uses not involving a potential nuisance in terms of smoke, noise, odor, vibration, heat, light or industrial waste. In addition, the Comprehensive Plan recognizes that it is important to promote adaptive reuse of older industrial areas and to allow Industrial Mixed-Use projects and Adaptive Reuse Projects. The Comprehensive Plan should be used to determine appropriate locations for this zone and for Industrial Mixed-Use Projects. Consideration should be given to the relationship of this zone to the surrounding land uses and to the adequacy of the street system to serve the anticipated traffic needs.

8-22(b) Principal Uses (Other uses substantially similar to those listed herein shall also be deemed permitted.)

1. The principal permitted uses in the B-4 zone.
2. The manufacturing, compounding, assembling, processing, packaging, or similar treatment of articles of merchandise from the following previously prepared materials: asbestos, bone, canvas, cellophane, cellulose, cloth, cork, feather, felt, fiber, fur, glass, hair, horn, leather, paper, plastics, precious and semi-precious metals, precious and semi-precious stones, rubber, sheet metal (excluding large stampings), shell, textiles, tobacco, wax, wire, wood (excluding sawmills, planing mills), and yarn.
3. The manufacturing, compounding, assembling, processing, packaging, or similar treatment of such products as: bakery goods; billboards; candy; ceramics; cosmetics; drafting instruments; electrical parts; appliances; electric or neon signs; electronic instruments; food products; meat packaging; ice cream; medical and dental instruments; musical instruments; pharmaceuticals; pottery, china, or figurines; radios; record players; rubber and metal stamps; rubber products; scientific instruments and equipment; shoes; television receivers; toiletries, soaps and detergents; toys; and watches and clocks.
4. Other industrial and manufacturing uses, such as auto parts rebuilding; battery manufacturing; beverage manufacturing; micro-brewery as regulated by KRS 243.157 and KRS 243.150; dairy and non-dairy and food and non-food product bottling plants; box and crate assembly; building materials sales; rental storage yard; bag, carpet and rug cleaning and dyeing; cabinet shop; cannery; cooperage; columbariums and crematories; dextrine and starch manufacturing; enameling, lacquering, and japanning; felt manufacturing; electric foundry; furniture manufacturing; heating equipment manufacturing; inflammable underground liquid storage; iron works (ornamental), and wire drawing; parcel delivery stations; phonograph record manufacturing; public utility service yard; radium extraction; railway or truck terminal; stone monument works; tool manufacturing; vehicle storage yards for which occupancy permits were issued prior to May 1, 1985; welding, and other metal working shops.
5. Recycling, sorting, baling and processing of glass and nonferrous metals, including copper; brass; aluminum; lead and nickel, but not including automobile wrecking yard; building materials salvage; junk yards or other uses first permitted in the I-2 zone. Recycling, and processing of paper shall be permitted only when wholly conducted in a completely enclosed building.
6. Industrial Mixed-Use Projects, as further regulated by Article 8-22(o).
7. Adaptive Reuse Projects, as set out in Section 8-21(b)23 and Section 8-21(o)4.
8. Commercial wood lots, provided that:
 - a. All wood storage and processing activities are located at least 300 feet from the nearest residential zone;
 - b. Wood piles are no greater than fifteen (15) feet in height, no greater than twenty (20) feet in width, no greater than 100 feet in length, and are spaced no less than twenty (20) feet from any property line; and
 - c. Cutting and splitting of timber takes place only between the hours of 8:00 a.m. and 5:00 p.m. on weekdays.

8-22(c) Accessory Uses (Uses and structures which are customarily accessory, clearly incidental and subordinate to permitted uses.)

1. Off-street parking areas and structures; loading facilities.
2. Dwelling units for watchmen or caretakers, provided that such facilities shall be located on the same premises as the permitted use.
3. Outdoor storage of products manufactured on the premises or materials to be used in manufacture on the premises.
4. Facilities for serving food only for employees and visitors; having no direct access to the exterior, and having no signs visible from the exterior of the building. Mobile food unit vendors may also serve this purpose, and be parked outside of a building

to serve employees and visitors, provided that the requirements of Section 15-11 of the Code of Ordinances are met.

5. Offices.
6. Recreational facilities, except as prohibited herein.
7. Sale of manufactured goods.
8. Sale of finished products related or incidental to the principal use, provided that the area set aside for sales of these related or incidental items does not constitute more than thirty percent (30%) of the total floor and storage area.
9. Satellite dish antennas, as further regulated by Article 15-8.
10. Beauty salons where accessory to an athletic club facility, provided that the area of the salon shall not constitute more than 10% of the total floor area, that the salon has no separate external entrance, nor separate business signage.
11. Retail sale of liquid propane (limited to 20-lb. containers), when accessory to retail sale of building materials and lumber permitted under Article 8-21(b)(18).

8-22(d) Conditional Uses (Permitted only with Board of Adjustment approval.)

1. Automobile, truck, ATV, motorcycle, bicycle motocross, or other vehicle or bicycle race tracks.
2. Public utilities and public service uses and structures.
3. Penal or correctional institutions.
4. Grain drying, when operated in a fully enclosed building at least 300 feet from the nearest residential, business, or professional office zone.
5. The above- or below-ground storage for resale of any flammable or nonflammable gas or oxidizer in liquid or gaseous form; the storage of any empty container that contained any gas in any form; and the receiving of or dispensing of any gas in any form, unless in association with an automobile and vehicle refueling station or limited by 8-22(e); and provided such operations conform to the standards prescribed by the National Fire Protection Association, the Kentucky Occupational Safety and Health Standards for General Industry, and any requirements of the Fire Marshall. Such conformance shall be certified in writing by the Fire Marshall, and any required protective measures for the containers shall be met in all ways.
6. Banks, with or without drive-through facilities, except as provided as part of an Industrial Mixed-Use Project or an Adaptive Reuse Project, provided:
 - a. The site lies within the area of a development plan approved by the Planning Commission, having a minimum 100 acres zoned industrial;
 - b. There shall be an on-site stacking capacity of a minimum of twenty (20) cars for each bank having drive-through facilities;
 - c. The site shall not have direct access to an arterial street;
 - d. There exists, within the development plan area, industrial businesses having a full-time, non-seasonal, on-site total employee population of at least 500 employees;
 - e. There exists, within a one-mile radius of the property boundaries of the proposed site, industrial businesses having a full-time, non-seasonal, on-site total employee population of at least 2,500 employees;
 - f. A site development plan is submitted to, and approved by, the Board of Adjustment and the Planning Commission.
7. Concrete mixing and concrete products, but only when the proposal complies with the requirements of the Mining/Quarrying Ordinance (Code of Ordinances #252-91) and the conditions and requirements as set forth therein, and only under the following conditions:
 - a. That no concrete mixing operation be conducted closer than 1,000 feet from any existing residence on another lot under different ownership.
 - b. Noise, Air & Water Quality - The facility shall be operated at all times in compliance with applicable Federal, State and local laws and regulations on noise, air, and water quality, including the LFUCG Noise Ordinance (Sections 14-70 through 14-80), Article 6-7: Stormwater Disposal Standards, and Chapter 16 of the Code of Ordinances.
 - c. Development Plan - The development plan shall indicate all existing contours, shown with intervals sufficient to show existing drainage courses, retention, storm water and sedimentation basins; and the names and locations of all streams, creeks, or other bodies of water within 500 feet.
 - d. Drainage and Erosion Control - All operations shall have adequate drainage, erosion, and sediment control measures incorporated in the site/development plan(s). If, in the event that adequate drainage, erosion, and sediment control cannot be provided, permits may be denied.
 - e. Roads - All access roads that intersect with a State highway or public street shall be paved with an all-weather surface of either asphalt or concrete for the entire length of road from State highway or street to the active loading point. Internal roads may be unpaved, provided dust is adequately controlled.
 - f. Screening - Screening shall be provided as defined in accordance with LFUCG Article 18 of the Zoning Ordinance.
 - g. Transportation Plan - A Transportation Plan shall be planned (in relationship to the arterial roadway system) to minimize the impact of traffic, dust, and vehicle

noise on areas outside the site and shall include the following information:

- 1) Product shipping and deliveries;
 - 2) Mode of transportation;
 - 3) Route(s) to and from the site;
 - 4) Schedule and frequency of shipments;
 - 5) Delivery and shipping spillage control methods;
 - 6) Employee parking.
- h. Storage - Storage and/or stockpiles of hazardous materials shall be in a completely closed building. Outdoor storage, except aggregate, sand and recycled asphalt material, shall be enclosed on at least three sides by a solid wall or fence, not less than six (6) feet nor greater than eight (8) feet in height, and shall be placed at designated site(s) on the development plan. At the cessation of operation, all storage piles and/or stockpiles shall either be removed or graded and covered with a minimum of 18 inches of topsoil and/or other soil-making materials, and planted in accordance with Article 18 of the Zoning Ordinance.
- i. Excess Product and Waste - Excess product and waste, when disposed of on site, shall be in a designated area so as to prevent erosion and contamination of streams and waterways. At the cessation of operation, all outdoor storage piles and/or stockpiles shall either be removed or graded and covered with a minimum of 18 inches of topsoil and/or other soil-making materials, and planted in accordance with Article 18 of the Zoning Ordinance.
8. Cable television system facilities, including transmitting towers; antennas; earth stations; microwave dishes; relays; business offices; television studios; and storage facilities.
 9. Vehicle storage yards, for which occupancy permits were applied for on or after May 1, 1985.
 10. Commercial composting, provided that the following requirements are met:
 - a. That all such composting shall be conducted in a fully enclosed building.
 - b. That a permit-by-rule or letter of intent from the Division of Waste Management of the Kentucky Natural Resources and Environmental Protection Cabinet be obtained prior to submission of any application to the Board of Adjustment for a conditional use permit.
 - c. That a development plan, indicating access points and circulation routes; proposed signage; screening and landscaping; fencing and other significant geological or physical features of the property, be submitted as part of any application.
 - d. That the Board specifically consider and be able to find that the proposed use will not constitute a public nuisance by creating excessive noise, odor, traffic or dust.
 11. Helistops and heliports, provided such facilities conform to the requirements of all appropriate Federal, State and local regulations.
 12. Mining of non-metallic minerals, but only when the proposal complies with the requirements of the Mining/Quarrying Ordinance (Code of Ordinances #252-91) and the conditions and requirements as set forth therein. The Board of Adjustment shall specifically consider and be able to find:
 - a. That the proposed use will not constitute a public nuisance by creating excessive noise, odor, traffic, dust, or damage to the environment or surrounding properties;
 - b. That a reasonable degree of reclamation and proper drainage control is feasible; and
 - c. That the owner and/or applicant has not had a permit revoked or bond or other security forfeited for failure to comply with any Federal, State or local laws, regulations or conditions, including land reclamation, pertaining to the proposed use.
 13. Places of religious assembly, Sunday schools, and schools for academic instruction, when affiliated with a place of religious assembly or a religious entity, except as provided as part of an adaptive reuse project.
 14. Retail sale, except as provided as part of an Adaptive Reuse Project, of furniture and household-related items, such as antiques; fabrics; fixtures; furnishings; glassware and china, when accessory to its storage, refinishing, repairing or upholstery on the same premises.
 15. Community centers, except as provided as part of an Adaptive Reuse Project.
 16. Child care centers, except as provided as part of an Adaptive Reuse Project.
 17. Agricultural market and market gardens.
 18. Temporary structures designed for use or occupancy for 61 to 180 days per 12-month period
on a single property, calculating said period by cumulative consideration of the use of any
and all such structures on a single property.
 19. Circus, provided all structures are located not less than 200 feet from any residential zone; and further provided that all structures for housing animals shall be 200 feet from any residential zone, residential use, school, hospital, nursing home or rest home. A circus may not displace more than twenty-five percent (25%) of the minimum required parking for the site it occupies.
 20. Day Shelters.

21. Ecotourism activities to include campgrounds, commercial hiking, bicycling, and zip line trails; tree canopy trails; canoeing and kayaking launch sites; recreational outfitters; fishing and hunting clubs; botanical gardens; nature preserves; and seasonal activities.

8-22(e) Prohibited Uses (All uses other than those listed as principal, accessory, or conditional uses or substantially similar to principal, accessory or conditional uses shall be prohibited. The uses below are provided for illustration purposes and for the purpose of limiting permitted uses, and are not intended to be a total listing of all the uses that are prohibited.)

1. The prohibited uses in the B-4 zone, items 3 through 11, and 14 through 16.
2. All uses first permitted in the I-2 zone, except as specifically permitted herein.
3. A facility for the storage and distribution of gas by railroad tank cars, through gas piping, or by tank trucks, which each have a water capacity in excess of 4,000 gallons.
4. Slaughterhouses.
5. Equine trails, children's rides, pony rides and petting zoos.

Lot, Yard, and Height Requirements (See Articles 3 and 15 for additional regulations.)

8-22(f) Minimum Lot Size - No limitation.

8-22(g) Minimum Lot Frontage - No limitation.

8-22(h) Minimum Front Yard - 20'.

8-22(i) Minimum Each Side Yard - No limitation, except as provided in Section 8-22(o).

8-22(j) Minimum Rear Yard - No limitation, except as provided in Section 8-22(o).

8-22(k) Minimum Useable Open Space - No limitation.

8-22(l) Maximum Lot Coverage - No limitation.

8-22(m) Maximum Height of Building - 75', except when a side or rear yard abuts a Professional Office or Residential zone, then a 3:1 height-to-yard ratio.

8-22(n) Off-Street Parking (See Article 16 for additional parking regulations.)

As for B-4.

Manufacturing or Industrial Uses - One (1) space for every two (2) employees on a maximum working shift, with a minimum of five (5) spaces.

Automobile Race Tracks - One (1) space for every five (5) seats.

Correctional or Penal Institutions - One (1) space for each employee.

Accessory Dwelling Units - One (1) space per dwelling unit.

Retail Sales Facility for manufactured goods - One (1) space for every 400 square feet of floor area.

Industrial Mixed Use Projects - As for MU-3, except that off-site parking may be provided in conformity with Article 16-1(d).

Conditional Uses - Parking requirements for conditional uses are minimum requirements; the Board of Adjustment may require additional parking, as needed.

Combinations - Combined uses shall provide parking equal to the sum of individual requirements.

8-22(o) Special Provisions

1. All industrial uses shall be conducted in a completely enclosed building, except for outdoor storage uses, which shall be enclosed on all sides by a solid wall or fence not less than six (6) feet in height.
2. Except for Industrial Mixed Use Projects, all buildings and structures shall be at least 100 feet from any residential zone, unless the portion within that distance has no openings except stationary windows and doors that are designed and intended solely for pedestrian access.
3. Landscape buffer areas shall be required as set forth in Article 18.
4. An Industrial Mixed Use Project may be permitted by the Planning Commission upon the approval of a development plan, subject to the following requirements:

- a. The property must be in a location recommended in the Comprehensive Plan for Industrial Mixed Use, and should not displace an existing agriculture-related use permitted in the I-1 zone.
- b. At least twenty percent (20%) of the total floor area shall be devoted to residential use, at least ten percent (10%) shall be devoted to a principal permitted use in this zone or the Wholesale and Warehouse Business (B-4) zone, and no more than forty percent (40%) of the total floor area shall be occupied by retail uses.
- c. At least forty percent (40%) of the front building wall(s) of new buildings proposed for an Industrial Mixed Use Project shall be required to be built at the 20-foot setback.
- d. In addition to the uses otherwise permitted in the Light Industrial (I-1) zone, the following uses shall be permitted in an Industrial Mixed Use Project:

As Principal Permitted uses:

1. Dwelling units.
2. Uses permitted in the Professional Office (P-1) zone, excluding a Professional Office Project.
3. Uses permitted in the Neighborhood Business (B-1) zone.

As Conditional uses:

1. Restaurants, without live entertainment or dancing, which devote more than twenty percent (20%) of the public floor area exclusively to the preparation and service of malt beverages, wine or alcoholic beverages.
2. Restaurants or nightclubs offering live entertainment and/or dancing, brew-pubs, cocktail lounges or nightclubs, wine or spirit-tasting rooms [unless prohibited under Sections 8-16(e)(14) and (15)]. Such uses shall be located at least 100 feet from any residential zone and shall be soundproofed to the maximum extent feasible by using existing technology, with noise or other emissions not creating a nuisance to the surrounding neighborhood.

As Prohibited uses:

1. All adult uses listed in Sections 8-16(e)(14) through (17) of the Zoning Ordinance.

- e. The minimum and maximum mix of uses shall be calculated based on the overall Industrial Mixed Use Project shown on the development plan. Each building within the Industrial Mixed Use Project shall not be required to contain a mixture of uses, provided that at least one structure shall contain a mixture of uses.

8-23 HEAVY INDUSTRIAL (I-2) ZONE

8-23(a) Intent - This zone is intended for manufacturing, industrial, and related uses that involve potential nuisance factors. It is also intended to encourage Adaptive Reuse Projects of older structures in or adjoining the Infill and Redevelopment Area. The Comprehensive Plan should be used to determine the appropriate locations for this zone. Consideration should be given to the relationship of this zone to the surrounding land uses and to the adequacy of the street system to serve the anticipated traffic needs.

8-23(b) Principal Uses (Other uses substantially similar to those listed herein shall also be deemed permitted.)

1. The principal permitted uses in the I-1 zone, provided that all provisions outlined therein shall apply for said uses in this zone.
2. Abrasives manufacturing.
3. Acid (non-corrosive) manufacturing.
4. Aerosol packaging.
5. Agricultural uses, including hatcheries.
6. Asbestos manufacturing.
7. Automobile assembling, rebuilding, and reconditioning.
8. Bleaching plant.
9. Boiler shops, structural steel fabricating shops, steel car or locomotive shops, railway repair shops, metal working shops, operative reciprocating hammers or chisels or other noise-producing machine operated tools.
10. Bolt or screw thread rolling or cutting.
11. Bottle making.
12. Brewery, winery and distillery.
13. Brick, tile and terra-cotta and other clay products manufacturing.
14. Briquette manufacturing from previously prepared charcoal.
15. Bronze casting.
16. Candle or sperm oil manufacturing.
17. Canvas manufacturing.
18. Carpet or rug manufacturing.

19. Coke manufacturing.
20. Concrete mixing, concrete products.
21. Correctional institutions.
22. Die casting and making.
23. Disinfectant, insecticide, or poison manufacturing.
24. Dye or dyestuff manufacturing and printing ink manufacturing.
25. Electric power generating plant.
26. Excelsior and fiber manufacturing.
27. Fencing, woven wire manufacturing.
28. Fertilizer manufacturing.
29. Forge.
30. Foundry.
31. Gas storage: Above- or below-ground storage for resale of flammable or non-flammable gas or oxidizer in liquid or gaseous form, the storage of any empty container which contained any gas in any form, and the receiving of or dispensing of any gas in any form unless the method of distribution is first permitted as a conditional use in this zone; and provided such operations conform to the standards prescribed by the National Fire Protection Association, the Kentucky Occupational Safety and Health Standards for General Industry, and any requirements of the Fire Marshall. Such conformance shall be certified in writing by the Fire Marshall, and any required protective measures for the containers shall be met in all ways. Any outside storage area must be enclosed on all sides by a fence or a solid wall, not less than six (6) feet in height.
32. Glass fiber manufacturing.
33. Glucose manufacturing.
34. Grain drying and poultry feed manufacturing from refuse, mash, or grain.
35. Hair manufacturing.
36. Iron storage, sorting, collecting or baling.
37. Leaf mold and similar plant material processing or manufacturing.
38. Linoleum, oil cloth or oiled goods manufacturing.
39. Match manufacturing.
40. Nitrating processes.
41. Oil, paint, shellac, turpentine, varnish or enamel manufacturing or the grinding of colors by machine.
42. Paper or pulp manufacturing.
43. Paper scrap or waste storage, sorting, collecting or baling.
44. Perfume manufacturing.
45. Plaster manufacturing and products.
46. Potash manufacturing or refining.
47. Pyroline plastic manufacturing.
48. Railroad roundhouse or yards.
49. Roofing material factory.
50. Rubber manufacturing, treating or reclaiming plant.
51. Sand blasting.
52. Sewage treatment plant.
53. Shoe blacking or polish manufacturing.
54. Soda ash, caustic soda or washing compound, containing chlorine bleaching powder manufacturing or refining.
55. Stadium.
56. Steam power plant.
57. Storage, drying, or cleaning of rags, glass, cloth, paper or clippings, including sorting, refining, baling, wool pulling and scouring.
58. Sugar refining or starch manufacturing.
59. Tar or asphalt roofing or waterproofing manufacturing.
60. Textile manufacturing.
61. Tire manufacturing.
62. Vehicle storage yards.
63. Adaptive Reuse Projects, as set out in Section 8-21(b)3 and Section 8-21(o)4.

8-23(c) Accessory Uses (Uses and structures which are customarily accessory, clearly incidental and subordinate to permitted uses.)

The permitted accessory uses in the I-1 zone.

8-23(d) Conditional Uses (Permitted only with Board of Adjustment approval.)

1. Acid (corrosive) manufacturing.
2. Ammonia, chlorine or bleaching powder manufacturing.
3. Animal black, lamp black or bone black manufacturing.
4. Asphalt plant, but only when the following conditions are met:
 - a. That no asphalt plant be conducted closer than 1,000 feet from any existing residence on another lot under different ownership.
 - b. Noise, Air & Water Quality - The facility shall be operated at all times in compliance with applicable Federal, State, and local laws and regulations on

noise, air, and water quality, including the LFUCG Noise Ordinance (Sections 14-70 through 14-80), Article 6-7: Stormwater Disposal Standards, and Chapter 16 of the Code of Ordinances.

- c. Development Plan - The development plan shall indicate all existing contours, shown with intervals sufficient to show existing drainage courses, retention, stormwater and sedimentation basins; and the names and locations of all streams, creeks, or other bodies of water within 500 feet.
 - d. Drainage and Erosion Control - All operations shall have adequate drainage, erosion, and sediment control measures incorporated in the site/development plan(s). If, in the event, adequate drainage, erosion, and sediment control cannot be provided, permits may be denied.
 - e. Roads - All access roads which intersect with a State highway or public street shall be paved with an all-weather surface of either asphalt or concrete for the entire length of road from State highway or street to the active loading point.
 - f. Screening - Screening shall be provided as defined in accordance with LFUCG Article 18 of the Zoning Ordinance.
 - g. Transportation Plan - A Transportation Plan shall be planned (in relationship to the arterial roadway system) to minimize the impact of traffic, dust, and vehicle noise on areas outside the site and shall include the following information:
 - 1) Product shipping and deliveries;
 - 2) Mode of transportation;
 - 3) Route(s) to and from the site;
 - 4) Schedule and frequency of shipments;
 - 5) Delivery and shipping spillage control methods;
 - 6) Employee parking.
 - h. Storage - Storage and/or stockpiles of hazardous materials shall be in a completely closed building. Outdoor storage, except aggregate, sand and recycled asphalt material, shall be enclosed on at least three sides by a solid wall or fence, not less than six (6) feet nor greater than eight (8) feet in height, and shall be placed at designated site(s) on the development plan. At the cessation of operation, all storage piles and/or stockpiles shall either be removed or graded and covered with a minimum of 18 inches of topsoil and/or other soil-making materials, and planted in accordance with Article 18 of the Zoning Ordinance.
 - i. Excess Product and Waste - Excess product and waste, when disposed of on site, shall be in a designated area so as to prevent erosion and contamination of streams and waterways. At the cessation of operation, all outdoor storage piles and/or stockpiles shall either be removed or graded and covered with a minimum of 18 inches of topsoil and/or other soil-making materials, and planted in accordance with Article 18 of the Zoning Ordinance.
5. Automobile wrecking, scrap iron storage or wrecking.
 6. Blast furnaces.
 7. Building materials salvage yard.
 8. Celluloid and pyroxylin manufacturing or explosives, or inflammable cellulose or pyroxylin products manufacturing or storage.
 9. Cement, lime, gypsum, or plaster of Paris Manufacturing.
 10. Coal storage.
 11. Commercial composting, provided that the following requirements are met:
 - a. That all such composting shall be conducted in a fully enclosed building.
 - b. That a permit-by-rule or letter of intent from the Division of Waste Management of the Kentucky Natural Resources and Environmental Protection Cabinet be obtained prior to submission of any application to the Board of Adjustment for a conditional use permit.
 - c. That a development plan, indicating access points and circulation routes; proposed signage; screening and landscaping; fencing and other significant geological or physical features of the property, be submitted as part of any application.
 - d. That the Board specifically consider and be able to find that the proposed use will not constitute a public nuisance by creating excessive noise, odor, traffic or dust.
 12. Creosote manufacturing or treatment.
 13. Cupola or metal smelting furnace and ore or metal reduction.
 14. Distillation of coal, petroleum, refuse, grain, wood, or bones.
 15. Explosives manufacturing or storage, except for small arms ammunition.
 16. Fertilizer manufacturing using organic materials, compost or storage.
 17. Fish curing, smoking, or packing, fish oil manufacturing or refining.
 18. Gas (acetylene, illuminating or heating) manufacture or storage.
 19. Gas storage and distribution facility where the means of distribution is railroad tank cars, gas piping, or tank trucks, which may each have a water capacity in excess of 4,000 gallons; however, the volume shall be governed by National Fire Protection Association regulations.
 20. Glue manufacturing, size or gelatin manufacturing, where the processes include the refining or recovery of products from fish, animal refuse, or offal.
 21. Junk yard.
 22. Livestock feed yards.
 23. Machinery wrecking or storage yard.

24. Petroleum or inflammable liquids production, refining and storage.
25. Rock or stone crusher, or mill, but only when the proposal complies with the requirements of the Mining/Quarrying Ordinance (Code of Ordinances #252-91) and the conditions and requirements as set forth therein.
26. Slaughtering of animals or stockyards.
27. Smelting of aluminum, copper, tin, iron, zinc ore.
28. Steel mill.
29. Storage, curing or tanning of raw, green or salted hides or skins.
30. Sulphurous, sulphuric, nitric, picric, carbolic, or hydrochloric or other corrosive acid manufacturing.
31. Yard for storage of dismantled, or partially dismantled, automobiles.
32. Heliports and heliports, provided such facilities conform to the requirements of all appropriate Federal, State and local regulations.
33. Mining and/or quarrying of non-metallic minerals, but only when the proposal complies with the requirements of the Mining/Quarrying Ordinance (Code of Ordinances #252-91) and the conditions and requirements as set forth therein. The Board of Adjustment shall specifically consider and be able to find:
 - a. That the proposed use will not constitute a public nuisance by creating excessive noise, odor, traffic, dust, or damage to the environment or surrounding properties;
 - b. That a reasonable degree of reclamation and proper drainage control is feasible; and
 - c. That the owner and/or applicant has not had a permit revoked or bond or other security forfeited for failure to comply with any Federal, State or local laws, regulations or conditions, including land reclamation, pertaining to the proposed use.
34. Indoor recreational activities, except as provided as part of an Adaptive Reuse Project, that require buildings which, as a result of their size and design, are not compatible with residential and business zones, but would be compatible in the Heavy Industrial (I-2) zone, including indoor tennis courts; skating rinks; athletic club facilities and bowling alleys.
35. Transfer station, but only when the following conditions are met:
 - a. This use shall be conducted in a completely enclosed building. No transfer station shall be closer than 1,000 feet to any A-R zone, to any residential zone, nor to any existing residence on another lot under different ownership.
 - b. The facility shall be operated at all times in compliance with applicable Federal, State and local laws, including Health Department regulations; regulations on noise, air, and water quality; and this Zoning Ordinance. A plan demonstrating proposed conformance with these requirements shall be submitted as part of any application.
 - c. A site/development plan, indicating existing screening and landscaping, fencing and significant geological or physical features of the property, shall be submitted as part of any application. The development plan shall be prepared by either an engineer, architect, landscape architect, land surveyor, or certified planner. This plan should also indicate all existing contours, drainage courses, retention, stormwater and sedimentation basins; and the names and locations of all streams, creeks, or other bodies of water within 500 feet of the proposed transfer station. The facility shall have adequate groundwater monitoring, waste spillage, and liquid waste/ leachate containment measures incorporated into the building and site, and all liquid waste must be disposed of via sanitary sewers. In the event adequate waste liquids/leachate containment, delivery controls and spillage control methods cannot be provided, the conditional use permit may be denied.
 - d. The site/development plan should also indicate access points, proposed signage, and internal circulation designed to minimize the impact of traffic, dust, and vehicle noise on areas outside the site. All roads to the site should be of sufficient width and constructed to safely handle all sizes of trucks, while being easily accessible to Federal or State highways. The plan shall identify (at a minimum) the route(s) to and from the site, the schedule and frequency of shipments, employee parking areas, and stacking areas for trucks. The Board shall review the location of access points to ensure that no traffic hazards are created.
 - e. All driveways and stacking areas shall be paved or sealed to prevent dust.
 - f. No transfer station shall be located within a 100-year floodplain or sinkhole area.
 - g. No waste shall remain overnight at the site.
 - h. This use shall be conducted only between the hours of 7:00 a.m. - 7:00 p.m.
 - i. The operator shall identify and employ misting, spritzing, masking agents, or absorption agents to control offensive odors.
 - j. The Board of Adjustment shall specifically consider and be able to find that the proposed use will not constitute a nuisance by creating excessive noise, water pollution, odor, truck traffic, vermin or other disease vectors, dust or other public health hazards. The Board shall also be able to find that the applicant has demonstrated specific measures in their application and plans that assure compliance with the applicable state environmental performance standards of 401 KAR 47:030.

36. Temporary structures designed for use or occupancy for 61 to 180 days per 12-month period on a single property, calculating said period by cumulative consideration of the use of any and all such structures on a single property.
37. Circuses, provided all structures are located not less than 200 feet from any residential zone; and further provided that all structures for housing animals shall be 200 feet from any residential zone, residential use, school, hospital, nursing home or rest home. A circus may not displace more than twenty-five percent (25%) of the minimum required parking for the site it occupies.
38. Ecotourism activities to include campgrounds; commercial hiking, bicycling and zip line trails; tree canopy trails; canoeing and kayaking launch sites; recreational outfitters; fishing and hunting clubs; botanical gardens; nature preserves; and seasonal activities.
39. Market gardens.

8-23(e) Prohibited Uses (All uses other than those listed as principal, accessory, or conditional uses or substantially similar to principal, accessory, or conditional uses shall be prohibited. The uses below are provided for illustration purposes and for the purpose of limiting permitted uses, and are not intended to be a total listing of all the uses that are prohibited.)

1. The prohibited uses in the B-4 zone, items 3 through 11, and 14 through 16.

Lot, Yard, and Height Requirements (See Articles 3 and 15 for additional regulations.)

8-23(f) Minimum Lot Size - No limitation.

8-23(g) Minimum Lot Frontage - No limitation.

8-23(h) Minimum Front Yard - 20'.

8-23(i) Minimum Each Side Yard - No limitation, except as provided in Section 8-23(o).

8-23(j) Minimum Rear Yard - No limitation, except as provided in Section 8-23(o).

8-23(k) Minimum Useable Open Space - No limitation.

8-23(l) Maximum Lot Coverage - No limitation.

8-23(m) Maximum Height of Building - As for I-1.

8-23(n) Off-Street Parking (See Article 16 for additional parking regulations.)

As for I-1.

8-23(o) Special Provisions

1. All buildings, outside storage areas, loading and working areas (except accessory parking) in conjunction with uses which are first permitted in the I-2 zone shall be located at least 300 feet from any residential zone and at least 100 feet from any other zone except B-4, I-1, or A-R.
2. Landscape buffer areas shall be required as set forth in Article 18. As to transfer stations, except in all cases at least a 15-foot landscape buffer shall surround the transfer station use.
3. Outside storage and working areas (except accessory parking) shall be enclosed by a solid wall or fence, not less than six (6) feet in height.

8-24 OFFICE, INDUSTRY AND RESEARCH PARK (P-2) ZONE

8-24(a) Intent - This zoning category is created to provide for a mixture of compatible office, research, warehouse and industrial uses in a park-like setting with high quality standards of development. This zone shall be located as recommended by the Comprehensive Plan. While it is recognized that actual development of property zoned P-2 may occur in increments smaller than the total acreage shown on the Comprehensive Plan, the terms "P-2 area" and "P-2 park" as used herein are intended to mean the entire contiguous area of ORP as designated on the Comprehensive Plan. The limitations on retail and hotel/motel uses stated herein have been drafted with the expectation that a P-2 project will include all such property as shown on the plan.

8-24(b) Principal Uses (Other uses substantially similar to those listed herein shall also be deemed permitted.)

1. Banks, credit agencies, security and commodity brokers and exchanges, credit institutions, savings and loan companies, holding and investment companies.
2. Offices for business, professional, governmental, civic, social, fraternal, political, religious, and charitable organizations.

3. Research development and testing laboratories or centers.
4. Colleges, universities, business colleges, technical or trade schools, and other schools and institutions for academic instruction, including dormitory facilities.
5. Libraries, museums, art galleries, and reading rooms.
6. Medical and dental offices, clinics, and laboratories.
7. Telephone exchanges, radio, and television studios.
8. Studios for work or teaching of fine arts, such as photography; music; drama; dance; and theater.
9. Community centers and private clubs.
10. Computer and data processing centers.
11. Ticket and travel agencies.
12. Television system signal distribution centers and studios.
13. Meeting and conference centers.
14. Storage and warehousing, when conducted in a completely enclosed building.
15. Parking lots and structures.
16. Offices of purchasers, processors, and handlers of agricultural products, limited to administrative uses only.
17. The manufacturing, compounding, assembling, processing, packaging, or similar treatment of articles of merchandise from the following previously prepared materials: bone, canvas, cellophane, cellulose, cloth, cork, feather, felt, fiber, fur, glass, hair, horn, leather, paper, plastics, precious and semi-precious metals, precious and semi-precious stones, rubber, sheet metal (excluding large stampings), shell, textiles, tobacco, wax, wire, wood (excluding sawmills, planing mills), and yarn.
18. The manufacturing, compounding, assembling, processing, packaging, or similar treatment of such products as: bakery goods; billboards; candy; ceramics; cosmetics; drafting instruments; electrical parts; appliances; electric or neon signs; electronic instruments; food products; meat packaging; ice cream; medical and dental instruments; musical instruments; pharmaceuticals; pottery, china, or figurines; radios; record players; rubber and metal stamps; rubber products; scientific instruments and equipment; shoes; television receivers; toiletries, soaps and detergents; toys; and watches and clocks.
19. Other industrial and manufacturing uses, such as beverage manufacturing; dairy and non-dairy, and food and non-food product bottling plants; box and crate assembly; cabinet shop; cannery; caterers; cooperage; crematory; dextrine and starch manufacturing; enameling, lacquering and japanning; furniture manufacturing; heating equipment manufacturing; inflammable underground liquid storage; iron works (ornamental), and wire drawing; parcel delivery stations; phonograph record manufacturing; public utility service yard; and tool manufacturing.
20. Recycling, sorting, baling and processing of glass, nonferrous metals (not including automobile wrecking yard), paper scrap and storage of waste paper, when wholly conducted in a completely enclosed building.
21. Hotels and motels, as specifically regulated under Article 8-24(o)(12) herein below.
22. Indoor and outdoor athletic facilities, such as field houses; gymnasiums; soccer; polo; and baseball fields.
23. Outdoor recreational facilities, including swimming pools; tennis courts; golf courses and golf driving ranges, and similar uses.
24. Agricultural research and experimentation facilities.
25. Kindergartens, nursery schools, and child care centers for four (4) or more children. A fenced and screened play area shall be provided, which shall contain not less than twenty-five square feet per child.
26. One designated retail sales area per P-2 project, limited to the following uses:

Offices for business, professional, governmental, civic, social, fraternal, political, religious, and charitable organizations.

Banks, credit agencies, security and commodity brokers and exchanges, credit institutions, savings and loan companies, holding and investment companies.

Establishments for the retail sale of food products, as per Article 8-16(b)(2).

Medical and dental offices, clinics, and laboratories.
Ticket and travel agencies.

Restaurants, cocktail lounges and night clubs, with entertainment, dancing, and/or sale of alcoholic beverages.

Establishments for the retail sale of merchandise, as per Article 8-16(b)(4).

Beauty shops, barber shops, and shoe repair.

Automobile service stations.

Quick copy services utilizing xerographic or similar processes, but not including offset printing methods.

Laundry and laundry pick-up stations, but not including self-service laundry.

Kindergartens, nursery schools and child care centers for four (4) or more children. A fenced and screened play area shall be provided, which shall contain not less than 25 square feet per child.

Athletic club facilities.

Market gardens.

27. Temporary cellular telephone transmitting facility; not to exceed 70' in height and with a 1:1 height-to-yard ratio.

28. Adult day care centers.

29. Day Shelters.

8-24(c) Accessory Uses (Uses and structures which are customarily accessory, clearly incidental, and subordinate to permitted uses.)

1. The accessory uses permitted in the P-1, B-4, and I-1 zones, except as specifically prohibited in Article 8-24(e) below.
2. Within the designated retail area, the following accessory uses shall be permitted:

Parking areas and structures.

One dwelling unit for the owners, operators, or employees of a permitted use, provided that such dwelling unit shall be a part of the building and located above or to the rear of such permitted use.

Warehousing, wholesaling, and storage, excluding outdoor storage.

Drive-through facilities for the sale of goods or products or the provision of services otherwise permitted herein.

Satellite dish antennas, as further regulated by Article 15-8.

3. Residential uses solely for incidental use by employees of a permitted use.

8-24(d) Conditional Uses (Permitted only with Board of Adjustment approval.)

1. Helistops and/or heliports, provided such facilities conform to the requirements of all appropriate Federal, State, and local regulations.
2. Mining of non-metallic minerals, but only when the proposal complies with the requirements of the Mining/Quarrying Ordinance (Code of Ordinances #252-91) and the conditions and requirements as set forth therein. The Board of Adjustment shall specifically consider and be able to find:
 - a. That the proposed use will not constitute a public nuisance by creating excessive noise, odor, traffic, dust, or damage to the environment or surrounding properties;
 - b. That a reasonable degree of reclamation and proper drainage control is feasible; and
 - c. That the owner and/or applicant has not had a permit revoked or bond or other security forfeited for failure to comply with any Federal, State or local laws, regulations or conditions, including land reclamation, pertaining to the proposed use.
3. Gasoline pumps available to the public without an employee on site, provided a plan is approved by the Board of Adjustment for periodic inspection of the site by an employee for the following purposes:
 - a. To check all operating equipment;
 - b. To check fire suppression system(s);
 - c. To check the condition of the fire alarm(s);
 - d. To check for indications of fuel leaks and spillage;
 - e. To remove trash from the site;
 - f. To monitor the general condition of the site.
4. Temporary structures designed for use or occupancy for 61 to 180 days per 12-month period on a single property, calculating said period by cumulative consideration of the use of any and all such structures on a single property.
5. Automobile and vehicle refueling stations, provided such uses conform to all requirements of Article 16.
6. Ecotourism activities to include zip line trails; tree canopy tours; canoeing and kayaking launch sites; fishing clubs; and seasonal activities.

8-24(e) Prohibited Uses (All uses other than those listed as principal, accessory, or conditional uses, or substantially similar to principal, accessory, or conditional uses shall

be prohibited. The uses below are provided for illustration purposes and for the purpose of limiting permitted uses and are not intended to be a total listing of all the uses that are prohibited.)

1. Dwellings, except as accessory uses for watchmen or caretakers, or as permitted under 8-24(c)(2) and (3) above.
2. All outdoor storage, display, and/or sales areas, including any vehicular sales facilities; but excluding outdoor patio areas operated in conjunction with a restaurant.
3. Any uses first permitted in the Heavy Industrial (I-2) zone.
4. Refuse dumps, incinerators, and landfills.
5. A facility for the storage and distribution of gas by railroad tank cars, through gas piping, or by tank trucks which each have a water capacity in excess of 4,000 gallons.
6. Ecotourism activities, except as permitted herein.

Lot, Yard, and Height Requirements (See Articles 3 and 15 for additional regulations)

8-24(f) Minimum Lot Size - Five (5) acres, except in the designated retail area and areas which have been approved for a final development plan, then no limitation. See 8-24(o)6 below.

8-24(g) Minimum Lot Frontage - No limitation.

8-24(h) Minimum Front Yard - 200' on streets classified as expressways and major arterials on the official functional classification map; 100' for all other street frontages, except cul-de-sacs, which shall have a minimum front yard of 25'. The designated retail area shall have a minimum front yard of 50'.

8-24(i) Minimum Side Yard - A combined side yard of 50', with a minimum of 25'.

8-24(j) Minimum Rear Yard - 25'.

8-24(k) Minimum Useable Open Space - See 8-24(o) below.

8-24(l) Maximum Lot Coverage - 30%; with a maximum floor area ratio of .4, except in the designated retail area, which shall have a maximum lot coverage of 25%, with a maximum floor area ratio of .5.

8-24(m) Maximum Height of Building - 1:1 height-to-yard ratio.

8-24(n) Off-Street Parking (See Article 16 for additional parking regulations.)

Uses first permitted in the B-4 zone - As per B-4.

Uses first permitted in the I-1 zone - As per I-1.

Office Uses - One (1) space for each 400 square feet of floor area.

Designated Retail Area - One (1) space for each 400 square feet of floor area for the first 10,000 square feet; one (1) space for each 200 square feet of floor area after the first 10,000 square feet.

Adult Day Care Center - One (1) space for every ten (10) persons being provided care, plus one (1) space per caregiver on the maximum shift.

Day Shelter - One (1) space for every ten (10) persons being provided services, plus one (1) space per staff member on the maximum shift.

Other Recreational Facilities or Ecotourism activities not otherwise stated herein - Five (5) spaces, plus one (1) space for each employee for each separate use.

Combinations - Combined uses shall provide parking equal to the sum of individual requirements.

8-24(o) Special Provisions

1. Any site to be zoned in a P-2 zoning category shall be a minimum of fifty (50) net acres in size.
2. No more than fifty percent (50%) of any P-2 project shall be covered with buildings and parking lots or other paved surfaces designed for vehicular use. All open space areas shall be permitted, however, to contain outdoor recreational/athletic facilities, such as ball fields; jogging trails; tennis courts; picnic areas; golf courses; or similar outdoor activities for the use of the employees of the principal use of the property or the public at large. Land owned by the developer at the time of

- rezoning, which is subsequently dedicated at no cost to the public as recreational or open spaces (not streets), shall be included in such open space requirement.
3. The developer shall be required to provide proof of at least the following private covenants having been created prior to the approval of any final development plan:
 - a. A design committee of at least three registered architects and landscape architects (mixed 2 to 1 in either combination) shall be required to review and approve all site and architectural designs within the development.
 - b. An owners' association or other mechanism which provides for uniform maintenance of all open space areas and common areas.
 4. Landscaping shall be required as per Article 18 of the Zoning Ordinance, except as modified herein. Perimeter landscaping around the exterior boundary of the project shall be as provided under Article 18 for the I-1 zone; however, the Commission may permit such portions of required perimeter planting to be reallocated to areas interior to the site, where it finds that solid screening is not needed to screen the uses from the adjoining rights-of-way or properties. In addition, ten (10) square feet of landscape area for each 100 square feet, or fraction thereof, of vehicular use area shall be required within the park. Street trees shall be required as outlined in the Land Subdivision Regulations. Each lot shall be required to provide on-site tree planting at a standard of 25 trees per acre, which shall include any street trees and trees planted within vehicular use areas. Existing trees may be substituted for such required new trees as outlined in Article 18-3(a)(7).
 5. Signage within the P-2 zone shall be specifically regulated under Article 17-7(m) of the Zoning Ordinance.
 6. A preliminary development plan shall be required to be filed in conjunction with any zoning map amendment to a P-2 zone. No building permits shall be issued for any lot or building within the development unless and until final development plans are approved, as provided in Article 21. The minimum size project for any final development plan shall be five (5) acres. A final development plan with two or more buildings shall be designed as a cohesive architectural statement, with all development features exhibiting compatible design elements. Where lots are proposed less than five (5) acres in size, the minimum lot, yard, and height requirements shall apply to the entire project, rather than to each subdivided lot.
 7. Parking areas shall not be permitted to encroach into required front, side, and rear yards. However, no more than 10 visitor parking spaces may be permitted within such required yards.
 8. In addition to the required development plan, the applicant for any P-2 zoning category shall be required to file a comprehensive development statement at the time of filing. Such comprehensive development statement shall include, at a minimum:
 - a. A traffic impact analysis.
 - b. A preliminary site analysis of all significant natural and man-made features with a particular emphasis on any environmentally sensitive areas, geologic hazard areas, existing vegetation which should be given priority as use for open space areas.
 - c. Any proposed use restrictions, building requirements, architectural requirements, or similar restrictions over those required herein.Such studies shall be evaluated by the staff as part of the overall review of the map amendment request and development plan. Based upon such review, the Planning Commission and/or Council may impose restrictions on uses or other development aspects, including design criteria, as a part of the approval of the P-2 project.
 9. A designated retail area can be included within the project at the option of the developer for any project containing over 100 net acres. If included, such designated retail area shall be defined on the preliminary development plan at the time of creation of any P-2 zone and shall be able to be expanded or relocated only with the approval of the legislative body as for a zone change. The designated retail area shall be designed and located to primarily serve the needs of employees and visitors to the Office, Industry and Research Park. It shall be located internal to the park and shall not be located on adjoining arterial streets. The retail area shall not be less than one percent (1%) of the total area of the park, nor greater than five percent (5%) of the total area of the park, in any case.
 10. Except to the extent otherwise permitted in Article 8-24(e) above, all uses shall be conducted in a completely enclosed building.
 11. No site utilities shall be permitted to be above ground, with the exception of major electric and telephone distribution lines (which shall generally be located on lot perimeters), pad mounted transformers, and similar facilities. Service connections of such utilities to individual buildings shall be required to be underground. Any utilities to be located above ground shall be shown on required final development plans. All such overhead utilities shall be designed, located, and, where appropriate, screened, so as to preclude visibility from adjoining arterial roadways and public open space and/or greenway areas to the greatest extent feasible.
 12. The number of hotels and/or motels within a P-2 project shall not exceed a total of one (1) per fifty (50) net acres of the P-2 project; and the total acreage in motel/hotel uses shall not exceed ten percent (10%) of the area of the P-2 project.

Section 4 – That Article 9 of the Zoning Ordinance of the Lexington-Fayette

Urban County Government be and hereby is amended, in part, to read as follows:

GROUP RESIDENTIAL PROJECTS

9-1 INTENT - The intent of this Article is to provide a means to permit two or more detached buildings for residential purposes to be placed on the same parcel or lot of land in any R-1T, R-3, R-4 or R-5 zone, if approved as a Group Residential Project as provided herein, and to allow slight variations from the requirements of the zone in which it is located only as specifically provided herein.

9-2 WHERE REQUIRED - Any development in an R-1T, R-3, R-4 or R-5 zone, which proposes two or more detached buildings for residential purposes on the same lot or parcel, shall be considered a Group Residential Project, and shall conform to the provisions of this Article.

9-3 PERMITTED USES - The permitted uses shall be those principal and accessory uses listed in Article 8 for the zone in which the Group Residential Project is located. All other uses are prohibited, except that (a) schools for academic instruction; (b) places of religious assembly; (c) canteens of less than 500 square feet in size for the sale of sundries and other incidental items to residents of the Project; (d) a sales or rental office of less than 1,200 square feet in size, where contracts or leases can be obtained or executed; (e) up to two (2) clubhouses for each Project; and (f) recreational facilities, with or without game rooms and/or one (1) indoor theater shall be permitted in a project approved by the Commission. Single family detached units permitted under the R-3 and R-4 zone are also prohibited from construction under the provisions of this Article. Such uses shall follow the requirements for subdividing, as required for single family residential zones.

9-4 DETACHED BUILDINGS DEFINED - For the purposes of this Article, detached buildings for residential purposes shall be defined as single family, two-family, or multi-family residential buildings, including ranch, motel or garden design types; town-houses; apartment buildings butted against each other; or apartment buildings connected by an open breezeway or similar connection. Buildings connected by breezeways or similar connections shall be considered to be detached buildings rather than one building. Ranch, motel, garden, butted buildings or other design types may be counted as single detached buildings, as long as they do not exceed 200 feet in length; and buildings exceeding this length shall be considered as two or more detached buildings, and shall be permitted only in Group Residential Projects.

9-5 REVIEW AND APPROVAL - The Division of Planning may approve site plans for a zoning compliance permit, after which the Division of Building Inspection may issue permits for the construction of a Group Residential Project on a lot of five (5) acres or less; provided the proposed Project meets the requirements set forth under Section 9-6. The Planning Commission shall review all other Group Residential Projects on lots of more than five (5) acres within ninety (90) days of their filing with the Division of Planning, unless the applicant agrees to a longer period. Projects of five (5) acres or less may also be submitted to the Commission. Regardless of the size, the Commission may only approve those Projects which meet the requirements of Section 9-6. The following procedure shall be followed for approval of Group Residential Projects by the Commission:

- (a) **DEVELOPMENT PLAN REQUIRED** - The Commission shall require a final development plan containing the information as required by Article 21; and, in addition, specifying the number and type of dwelling units for each building and use of other structures. The Commission shall review the plan for provision of safe, convenient, efficient and harmonious groupings of buildings in relation to their intended use; transportation and utilities in relation to the buildings served and general circulation needs; open space in relation to needs of the occupants; and for conformance to any other necessary requirements. The Project shall be planned to properly blend with all surrounding property.
- (b) **PUBLIC HEARING REQUIRED** - The Commission shall advertise and hold a public hearing before proceeding to postpone, approve, conditionally approve or disapprove the plan for a Group Residential Project. Amendments to the plan shall follow the same procedure as provided in Section 21-7.
- (c) **CERTIFICATION OF APPROVAL** - The certification of approval for a Group Residential Project development plan shall be as provided in Section 21-4(d).

- (d) **PERMITS REQUIRED** - After certification by the Secretary of the Commission, the Divisions of Planning and Building Inspection may issue permits in conformance with the approved plan upon receipt of a certified copy of the plan.

9-6 GROUP RESIDENTIAL PROJECT MINIMUM DESIGN STANDARDS - All Group Residential Projects shall conform to the following minimum design standards:

- (a) **SIZE** - The parcel or lot on which the Project is located shall not be less than the minimum lot area for the zone in which it is located.
- (b) **MAXIMUM FLOOR AREA RATIO AND LOT COVERAGE** - For Projects in the R-3, R-4 or R-5 zone, the total floor area of all buildings shall not exceed the maximum floor area permitted in the zone in which the Project is located, unless specific permission is given by the Commission to exceed said permitted floor area by not more than one percent (1%) for each one percent (1%) of additional usable open space that is provided over the minimum required by Section 9-6(h). In any case, the maximum floor area shall not exceed, by more than ten percent (10%), the maximum floor area otherwise permitted in the zone. The maximum lot coverage shall be as provided in the zone in which the Project is located. For Projects located in the R-1T zone, the total lot coverage shall not exceed twenty-five percent (25%) There shall be no maximum floor area ratio for Group Residential Projects in the R-1T zone.
- (c) **YARD REQUIREMENTS** - The minimum width of required yards shall be as follows:
- (1) **FRONT YARD** - Frontage along any public or private street shall constitute a front yard, and more than one may be designated for each Project, as appropriate. The front yard shall be established as follows:

Zone	Minimum Distance
R-1T	10 feet
R-3	20 feet
R-4	20 feet
R-5	20 feet

- (2) **PROJECT EXTERIOR YARD** - The Project exterior yard shall be established along the outside boundary of the property, except where a front yard has been established as required in Section 9-6(c)(1). Where a Project exterior yard is required, the distance between principal buildings and the outside boundary of the property upon which the Project is located shall not be less than the height of the building, nor twenty (20) feet, whichever is less. Where the wall of any principal building is not parallel to the outside boundary of the property or is broken or otherwise irregular, the average distance shall not be less than as specified above. At no point shall such distance be less than fifteen (15) feet.
- (3) **DISTANCES REQUIRED BETWEEN BUILDINGS** - The distances between principal buildings shall not be less than the required side yard in the zone in which the Project is located. Where the walls of the buildings are not parallel, or are broken or otherwise irregular, the average distance between the principal buildings shall not be less than as specified above, and shall at no point be less than one-half (½) the required side yard for the zone in which the Project is located.
- (d) **PROXIMITY TO DRIVE** - A part of every residential building shall not be farther than 160 feet from an access roadway or drive providing vehicular access from a public street. Residential buildings shall not be closer than five (5) feet to any access roadway or drive.
- (e) **MAXIMUM HEIGHT** - The maximum height of non-residential buildings within a Project shall be thirty-five (35) feet. The maximum height of residential or mixed-use buildings within a Project shall be as follows:

Zone	Maximum Height
R-1T	35 feet
R-3	40 feet

R-4	60 feet
R-5	80 feet

- (f) PARKING AREA - One and one-half (1½) off-street parking spaces shall be provided per dwelling unit or 0.9 spaces per bedroom in a multi-family dwelling, whichever is greater. Parking minimums may be reduced for the provision of bicycle and transit facilities as specified in Article 16-10 of the Zoning Ordinance.
- (g) SERVICE AREAS - Proper open spaces shall be devoted to service needs of the Project, including, among others, refuse collection areas and equipment service areas.
- (h) USABLE OPEN SPACE AND SCREENING - Proper usable open spaces shall be devoted to the recreation needs of the Project for active and passive use. For projects with less than ten (10) dwelling units, no usable open space shall be required. Projects with ten (10) or more dwelling units shall provide usable open space based on the density of the project as follows:

Density (d.u./net acre)	Usable open space required (% of net project area)
<5 d.u./acre	5%
5 to 15 d.u./acre	20%
16 to 40 d.u./acre	15%
>40 d.u./acre	10%

- (i) PRIVATE STREETS - Private streets may be permitted by the Commission. Plans containing private streets shall conform to the requirements of the Subdivision Regulations concerning private streets.
- (j) MAINTENANCE OF COMMON SPACES - Where the design of the Group Residential Project indicates a need or desire to subdivide property and to provide for common areas, a Home Owners' Association, or other mechanism for the provision of maintenance, improvement, and operations for all common areas, including streets; parking areas; open space, etc.; shall be required to be established by the applicant. The applicant's responsibility to create such a mechanism shall be noted on the development plan of the Group Residential Project. A requirement that each property owner be individually responsible for maintenance of the common space abutting the lot shall not be considered as acceptable for fulfilling the requirements of this section.
- (k) OTHER REQUIREMENTS - Except as modified herein, the Project shall conform to the requirements of this Zoning Ordinance for the zone in which it is located.

9-7 GROUP RESIDENTIAL PROJECTS IN THE INFILL AND REDEVELOPMENT AREA
- Projects in the Infill and Redevelopment Area shall follow the same procedures set out as provided in Sections 9-5 and 9-6 herein for Group Residential Projects, except that such Projects may utilize the following alternative minimum design standards:

- (a) PROVISIONS OF THE UNDERLYING ZONE - Projects in the Infill and Redevelopment Area may choose to comply in whole with the height; front, rear and side yard setbacks; and parking requirements as for the underlying zone rather than with Article 9-6(b) through 9-6(f) above.
- (b) BONUS FLOOR AREA - The maximum floor area shall not exceed 125% of the otherwise permitted maximum floor area in the zone in which the Project is located, provided the required usable open space has not been granted a dimensional variance. Any Project that proposes a total floor area of more than 100% of that permitted in the zone in which the Project is located, shall require that notice be provided to all property owners within 400 feet of the site, as outlined in Article 6-4(b) herein prior to Planning Commission consideration.

- (c) OPEN SPACE REDUCTIONS - For projects located within 1,000 feet of an existing LFUCG park space, the minimum required open space shall be reduced by 50%.
- (d) FRONT YARD AVERAGING - The front yard may be averaged as permitted in Section 15-2(a)(1) only if the primary wall plane of the building is parallel to the public or private street.

Section 5 – That Article 10 of the Zoning Ordinance of the Lexington-Fayette Urban County Government be and hereby is amended to read as follows:

MOBILE HOME PARK (M-1P) ZONE

10-1 INTENT - The intent of the Mobile Home Park (M-1P) zone is to permit the establishment of mobile home parks in areas which will provide a residential setting and which will be convenient to major traffic arterials. Because of unusual characteristics, mobile home parks pose special problems in the application of land use control techniques and require special consideration as to their proper location and character in relation to adjacent uses and to the proper integration of such uses into the community. The standards contained in this provision are intended to provide adequate protection and consideration for both the community and the mobile home dweller.

10-2 PERMITTED USES - The uses permitted in an M-1P zone are mobile home parks and those uses and structures which are customarily accessory, clearly incidental and subordinate to a mobile home park, such as satellite dish antennas, playgrounds, swimming pools, tennis courts, and similar non-commercial recreational buildings and facilities.

10-3 CONDITIONAL USES PERMITTED WHEN AUTHORIZED BY THE BOARD OF ADJUSTMENT

- a. Incidental retail uses, such as barber and beauty shops; self-service laundries; news and novelty stands; snack bars and commissaries conducted for the convenience of the residents of any mobile home park containing one hundred fifty (150) or more mobile home lots, when located wholly within a principal building with access only to an interior arcade or open court and having no exterior display space or identification sign visible from any adjacent public right-of-way; and provided that such uses do not exceed a total of 2,500 square feet in area.
- b. Nursery schools, day nurseries, and child care centers for four (4) or more children when located in a permanent structure, provided there is a fenced and screened play lot.

10-4 PROHIBITED USES - In any M-1P zone, all uses other than as specifically permitted are prohibited.

10-5 STRUCTURES ACCESSORY TO MOBILE HOMES

- a. No accessory building shall be constructed as a permanent part of a mobile home, nor shall any other device be attached other than a cloth or metal awning or similar device.
- b. Cabanas, ramadas, and other similar permanent structures may be erected in conjunction with a mobile home parking space, and shall not be closer to any other structure or mobile home other than the one it is intended to serve, than the minimum distance required between mobile homes.

10-6 MAXIMUM HEIGHT - The maximum height of any structure in an M-1P zone shall be twenty-five (25) feet.

10-7 LOCATIONAL STANDARDS - The following locational standards shall be met in the design of a mobile home park:

- a. A mobile home park shall have a minimum of two hundred (200) feet of frontage on a street designated by the Commission as an arterial or collector street and shall have its principal access to and from said street.
- b. The principal access to and from the mobile home park shall be at a location where traffic congestion does not exist at the present on the street or streets to be utilized for access to the proposed mobile home or trailer park; and the possibility of such congestion in the future shall be minimized by provision in the development plans for proper entrances and exits, and by internal provisions for traffic circulation and parking.

- c. No vehicular entrance or exit from a mobile home park shall be within two hundred (200) feet, measured along streets, from any property line of any lot containing a school; public playground; place of religious assembly; hospital; library; hospital; nursing or personal care facility; orphanage or rehabilitation home, except where such building or property is in another block or fronts on a street on which such mobile home park will have no entrance or exit.
- d. Each proposed mobile home park shall be well drained and properly graded to ensure proper drainage; shall have water service, sanitary sewer service, and shall be located so as to provide for the availability of community facilities and services such as schools, parks, shopping facilities, and police and fire protection.

10-8 MINIMUM DESIGN STANDARDS

- a. All new mobile home parks shall have a minimum site area of ten (10) acres. There shall be no area limitations on additions to existing parks containing fifty (50) or more mobile home spaces.
- b. There shall be a minimum of four thousand (4,000) square feet for each mobile home space.
- c. Not less than ten percent (10%) of the site on which a mobile home park is located shall be devoted to open space available to the residents of the entire park.
- d. Each mobile home lot shall have a minimum of twenty (20) feet of frontage on an improved access road or driveway.
- e. Each mobile home shall be located at least twenty (20) feet from any other mobile home, except that the end-to-end clearance shall not be less than fifteen (15) feet.
- f. Each mobile home shall be located at least twenty (20) feet from any permanent structure, service building or service area within the mobile home park, at least ten (10) feet from any property line, and at least twenty (20) feet from any street or dedicated right-of-way.
- g. No mobile home shall be located closer than twenty (20) feet to any other zone.

10-9 ACCESS ROADS AND PARKING

10-9(a) REQUIRED WIDTH - All access roads and drive- ways within a mobile home park shall be paved to a width of not less than twenty (20) feet and shall be improved in accordance with the requirements of the Division of Engineering.

10-9(b) PEDESTRIAN ACCESS - There shall be provided, along one (1) side of each access road and/or driveway, a sidewalk not less than three (3) feet in width to provide for pedestrian circulation throughout the mobile home park.

10-9(c) REQUIRED PARKING - There shall be provided on the same space with the mobile home, or on a lot contiguous thereto, or on an access road, at least two (2) parking spaces per mobile home lot. The required parking spaces may be located within the access road or driveway, provided that the portion thereof to be used exclusively for such parking is improved in accordance with the requirements of the Division of Engineering. The minimum width of an access road or driveway on which parking is permitted shall be twenty-nine (29) feet for one-side parking and thirty-eight (38) for both-side parking.

10-10 LANDSCAPING

10-10(a) SCREENING - Landscaping and screening shall be provided as required by Article 18: Landscape and Land Use Buffers.

10-10(b) OPEN SPACE - All required open space and other areas not used for mobile home spaces, access, parking, traffic circulation, buildings or service areas, shall be landscaped with grass or a ground cover as defined in Article 18 of this Zoning Ordinance.

10-11 PROCEDURE - The procedure for obtaining a zoning map amendment to the M-1P zone shall be the same as provided in Article 6 herein above and, in addition, as follows:

10-11(a) PRELIMINARY DEVELOPMENT PLAN REQUIRED - A preliminary development plan shall be submitted with the application for a zoning map amendment, with the information as required in Article 21: Development Plans herein below; and, in addition, the location and dimensions of all mobile home spaces, parking spaces and recreation areas.

10-11(b)FINAL DEVELOPMENT PLAN REQUIRED - Within two (2) years of final approval by the legislative body of any M-1P zoning map amendment, unless an extension is granted by the Commission, the applicant shall submit a final development plan to the Commission for its review and approval; otherwise, an application to change the M-1P zone to its previous zone, or other appropriate zone may be filed by the Commission as provided by Article 6 herein above. The final development plan shall show the information required by Article 21 herein below; and, in addition, the exact location of all mobile home spaces, parking spaces, and recreational areas. The Commission shall approve a final development plan with such conditions as are found necessary to comply with the Ordinance within ninety (90) days after the applicant submits the development plan.

10-11(c)BUILDING PERMIT REQUIRED - No building permit shall be issued until a final development plan has been approved by the Commission and certified to the Division of Building Inspection. The approved final development plan shall limit and control the issuance of all building permits; and shall restrict the construction, location, and use of all land and structures to all conditions set forth in the plan. Amendments to the plan can be made only as provided in Article 21.

10-11(d)CERTIFICATE OF OCCUPANCY REQUIRED - No certificate of occupancy shall be issued until a minimum of fifty (50) mobile home spaces have been completed, have sanitary sewer service available, and are otherwise ready for occupancy, unless a performance bond or letter of credit in an amount specified by the Division of Engineering has been submitted to the Commission to ensure completion of all improvements for the aforesaid fifty (50) spaces.

10-12MOBILE HOMES IN OTHER ZONES - No mobile home shall be parked, or maintained and used as a dwelling unit, on any lot or tract of land other than one located in an M-1P zone except as provided therein.

10-12(a)MOBILE HOMES IN INDUSTRIAL ZONES - In any industrial (I-1, I-2) zone, not more than one (1) mobile home or trailer for each establishment may be occupied as sleeping quarters for a caretaker or watchman.

10-12(b)MOBILE HOMES IN AGRICULTURAL ZONES - In any A-R, A-B, A-N or A-U zone, one (1) mobile home used as a tenant home accessory to the principal residence, which shall not be permitted to be a mobile home, may be located on a farm of forty (40) net acres or more as provided in Section 10-12(b)(1) through (3) below. On a farm of one hundred (100) net acres or more, a second mobile home used as a tenant home shall be permitted as set forth in Section 10-12(b)(1) through (3). On farms of two hundred (200) net acres or more, mobile homes used as tenant homes, in addition to the first two (2) permitted, shall be allowed at the rate of one (1) per one hundred (100) net acres, as set forth in Section 10-12(b)(1) through (3). The placement of any mobile home shall comply with all requirements set forth by the Board of Health of the Lexington-Fayette Urban Government and as follows:

Lot Size (net acres)	Number Permitted of Mobile Homes
40 Acres	1
100 Acres	2
200 Acres	3
300 Acres	4

(1) In any A-R, A-B, A-N or A-U zone, no mobile home shall be located closer than three hundred (300) feet to any existing or proposed right-of-way, nor shall any mobile home be located in a designated floodplain. One or more of the occupants of all mobile homes must be employed full-time in agricultural activity on the farm on which such mobile is located; or the mobile home must be used as an accessory dwelling by parents, or natural or adopted children of the owner of the primary dwelling unit of the farm. No mobile home shall be located closer than three hundred (300) feet to any property line.

(2) No more than one (1) driveway to any or all mobile homes located on property having common ownership shall be permitted for the first seven hundred fifty (750) feet of frontage. For property having more than seven hundred fifty (750) feet of frontage, additional driveways shall be permitted at the rate of one (1) per five hundred (500) feet of frontage.

(3) In an A-R, A-B, A-N or A-U zone, all mobile homes shall be fitted with skirtings around the base so as to conceal any wheels and/or chassis, and the towing tongue shall be removed.

(4) Any mobile home unoccupied for a period of one year shall be required to be removed from the premises.

10-13 ENLARGEMENT OF EXISTING PARKS - Any enlargement or extension of any existing mobile home park shall be in accordance with the requirements of this Article.

10-1 COMPLIANCE WITH OTHER LAW - Conformity with the standards established in this Ordinance shall not relieve the owner or operator of a mobile home park from compliance with all other requirements of the law.

Section 6 – That Article 12 of the Zoning Ordinance of the Lexington-Fayette Urban County Government be and hereby is amended to read as follows:

PLANNED SHOPPING CENTER (B-6P) ZONE

12-1 INTENT - The intent of the Planned Shopping Center (B-6P) zone is to encourage the logical and timely development of land for commercial purposes and the expansion of existing shopping centers in accordance with the Comprehensive Plan. The protective standards contained in this provision are intended to:

Assure convenience by providing commercial areas of sufficient size and in the proper location to serve conveniently the people of the area in relation to their purchasing power and their needs and demands for goods and services;

Assure traffic safety and provide for the improvement of major thoroughfare traffic capacities by properly locating and grouping commercial areas and by designing such commercial areas so as to provide safe and convenient access thereto and adequate off-street parking for automotive vehicles and by effectively separating vehicular from pedestrian traffic both within the commercial area and on adjacent public rights-of-way;

Provide for service vehicles by including convenient access and loading facilities in the design of commercial areas;

Protect adjacent residential neighborhoods from depreciation of property values resulting from commercial over-zoning, from the over-development or intrusion of undesirable commercial uses, and from the possible blighting effect of failed “big-box” retail establishments;

Promote community attractiveness by encouraging the design of commercial areas and “big-box” retail establishments which will integrate with residential areas by utilizing effectively topographic features, transitional areas, and the liberal application of landscaping and screening devices, thus minimizing any adverse effect of any such commercial area upon adjacent land uses and providing a pleasant environment for the shopping and working experience;

Improve the economic base and tax structure of the Lexington metropolitan area by encouraging the development of stable, economically sound commercial concentrations;

Protect the investments of existing and future commercial concentrations by providing the basis for convenient and stable commercial development through the application of sound planning principles.

12-2 TYPES OF SHOPPING CENTERS - The types of shopping centers provided for in this section may be generally described as follows:

A neighborhood shopping center is one which provides for the sale of convenience goods such as food, drugs, hardware and personal services, and has a minimum area of three (3) acres.

A community shopping center provides not only convenience goods, but a range of facilities for the sale of “shopping goods” such as apparel and home furnishings, as well as banking, professional services, and recreation. A community shopping center shall have a minimum area of ten (10) acres.

A regional shopping center generally provides more and larger facilities than the community shopping center. A regional shopping center shall have a minimum area of thirty (30) acres.

12-3 PRINCIPAL PERMITTED USES - The principal permitted uses in a B-6P zone shall be as follows:

- a. The principal permitted uses in the B-1 and P-1 zones.
- b. Indoor theaters.
- c. Parking lots and structures.
- d. Offices of veterinarians, animal hospitals or clinics, provided that (a) all exterior walls are completely soundproofed; (b) animal pens are located completely within the principal building; and (c) boarding is limited to only animals receiving medical treatment.
- e. Self-service car washes, provided that such uses shall be located at least 100 feet from any residential zone; that surface water from such establishment shall not drain onto adjacent property, and that adequate on-site storage lanes and parking facilities shall be provided so that no public way shall be used for such purposes.

12-4 ACCESSORY USES - The accessory uses permitted in a B-6P zone shall be as follows:

- a. The accessory uses in the B-1 and P-1 zones.
- b. Drive-through facilities for the sale of goods or products or the provision of services otherwise permitted herein, when approved by the Planning Commission on a development plan.

12-5 CONDITIONAL USES - Shall be as follows:

- a. Restaurants, cocktail lounges, brew-pubs, nightclubs, and discotheques offering live entertainment and/or dancing, unless otherwise prohibited. Such uses shall be located at least 100 feet from any residential zone and shall be soundproofed to the maximum extent feasible by using existing technology, with noise emissions not creating a nuisance to the surrounding neighborhood.
- b. Recycling drop-off centers for aluminum, steel, glass, newspapers, cardboard and other paper products, oil and other household recyclable waste; provided that such establishment shall be located at least 200 feet from any residential zone. Any appeal for a conditional use permit to operate a recycling drop-off center shall include as part of the application:
 1. Reasons for the location of the use at a specific site; description of equipment to be used; physical arrangement; and operation of the proposed center. The Board of Adjustment shall consider the necessity of screening, if needed.
- c. Mining of non-metallic minerals, but only when the proposal complies with the requirements of the Mining/Quarrying Ordinance (Code of Ordinances #252-91) and the conditions and requirements as set forth therein. The Board of Adjustment shall specifically consider and be able to find:
 1. That the proposed use will not constitute a public nuisance by creating excessive noise, odor, traffic, dust, or damage to the environment or surrounding properties;
 2. That a reasonable degree of reclamation and proper drainage control is feasible; and
 3. That the owner and/or applicant has not had a permit revoked or bond or other security forfeited for failure to comply with any Federal, State or local laws, regulations or conditions, including land reclamation, pertaining to the proposed use.
- d. Rehabilitation homes, when located closer than 500 feet from a residential zone; school for academic instruction or a child care center.
- e. Automobile and vehicle refueling stations, provided such uses conform to all requirements of Article 16.
- f. Drive-through facilities for the sale of goods or products or provision of services otherwise permitted herein, except as accessory uses herein.

12-6 PROHIBITED USES - In a B-6P zone, all uses other than as permitted herein are prohibited.

12-7 LOCATIONAL STANDARDS - A neighborhood or community shopping center shall abut, front on and have its principal access to and from a street designated by the Commission as an arterial or collector street, as deemed to be appropriate by the

Commission. A regional shopping center shall abut, front on and have its principal access to and from a street designated by the Commission as an arterial.

The proposed shopping center shall be at a location where traffic congestion does not exist at present on the streets to be utilized for access to the proposed shopping center, and where such congestion will be minimized by provision in the plan for proper entrances and exits, and by internal provisions for traffic circulation and parking.

The need for the proposed center at the proposed location, to provide adequate shopping facilities or service to the surrounding neighborhood or community, as the case may be, shall be demonstrated by the applicant by means of market studies or such other evidence as the Commission may require.

The proposed shopping center shall be of sufficient, but not excessive, size to provide adequate shopping facilities for the population which reasonably may be expected to be served by such shopping facilities.

12-8 MINIMUM DESIGN STANDARDS - The following minimum standards shall be met in the design of a planned shopping center:

12-8(a) HEIGHT REQUIREMENT - There shall be no height limitation.

12-8(b) REQUIRED SETBACK - All buildings shall be at least fifty (50) feet from the perimeter boundary of the B-6P zone. However, no more than 100 feet of exterior walls may be established at the same setback. A variation of at least three (3) feet shall be required where a break in setback occurs. Buildings may penetrate up to three (3) feet over the building line into the required setback, but the average setback shall be at least as great as the required setback.

12-8(c) SCREENING - Landscaping and screening shall be provided as required by Article 18 herein.

12-8(d) LOT COVERAGE - The ground area occupied by all the buildings shall not exceed, in the aggregate, thirty-five percent (35%) of the total area of the B-6P zone. Parking structures shall not be considered as a building for the purposes of this section.

12-8(e) REQUIRED PARKING - Notwithstanding any other requirements of this Zoning Ordinance:

1. For a neighborhood shopping center, two square feet of off-street parking area, including driveways, shall be provided for every square foot of parking floor area.
2. For a community or regional shopping center after May 29, 2003, one parking space shall be provided for every 250 square feet of gross floor area.
3. For community or regional shopping centers before May 29, 2003, three square feet of off-street parking, including driveways, shall be provided for every square foot of parking floor area.
4. For any shopping center containing residential use(s), the residential use(s) shall require 0.5 parking space per dwelling unit.

12-8(f) LOADING AREAS - Notwithstanding any other requirements of this Zoning Ordinance, there shall be provided one off-street loading space for each 20,000 square feet, or fraction thereof, of aggregate floor space of all buildings in the center. At least one-third of the space required shall be sufficient in area and vertical clearance to accommodate trucks of the tractor-trailer type. Such loading facilities shall be permanently and fully screened. The exact type and nature of such screening shall be determined by Article 18.

12-8(g) LIGHTING - Access ways and parking areas shall be lighted adequately by lighting fixtures, which shall be so installed as to reflect light away from adjoining properties. Cut-off shields, or equivalent lighting design, shall be utilized to prevent spillover of light from the shopping center to adjoining properties under different zoning. Security lighting and lighting located on the side and rear of buildings must also reflect light away from adjoining properties.

12-9 DESIGN GUIDELINES FOR "BIG-BOX" RETAIL ESTABLISHMENTS - It is in the best interest of Lexington-Fayette County to minimize the possible "blighting" effect that abandoned shopping centers and large retail establishments can have on the larger area or neighborhood in which they are located. By imposing additional standards in the form of design guidelines for such centers, these effects can be minimized, and future redevelopment and reuse of vacant retail buildings encouraged through proper facility design, without expenditure of public funds. For this reason, the Planning Commission has adopted design guidelines for shopping centers containing a single "big-box" establishment larger than 80,000 square feet in size. These additional standards are listed in "Design Guidelines for 'Big-Box' Establishments" incorporated by reference, and are consistent with guidelines which have been established in other cities and counties across the United States for such facilities. These design guidelines are intended to

provide professional designers and the Planning Commission with direction for improved development plans which address the following issues:

- (a) Variation in building heights and identifiable customer service entrances and pedestrian entryways;
- (b) Uninterrupted facades, windows, allowance for smaller stores or departments having exterior entrances, and back or side facades;
- (c) Landscaping and/or screening of outdoor display of building materials or other similar bulky products, and of trash collection and loading areas;
- (d) Pedestrian circulation in relation to vehicular movement and common open spaces for pedestrians;
- (e) Parking lot orientation adjacent to public streets.

The guidelines are to be met in the design of a planned shopping center containing a single "big-box" establishment larger than 80,000 square feet in size, unless waived by the Planning Commission through its approval of a final development plan for a property in a B-6P zone.

12-10PROCEDURE - The procedure for obtaining a zoning map amendment to the B-6P zone shall be the same as provided in Article 6 herein above, in addition, as follows:

12-10(a) PRELIMINARY DEVELOPMENT PLAN REQUIRED - A preliminary development plan shall be submitted with the application for a Zoning Map Amendment, with the information as specified in Article 21; and, in addition, approximate total gross floor area of anticipated retail facilities; the approximate total gross floor area of anticipated office and service facilities; the approximate number of anticipated off-street parking spaces; and the stages which will be followed in the construction of the proposed shopping center.

12-10(b) FINAL DEVELOPMENT PLAN REQUIRED - Within two (2) years of final approval by the Urban County Council of any B-6P Zoning Map Amendment, unless an extension is granted by the Commission, the applicant shall submit a final development plan to the Commission for its review and action; otherwise, an application to change the B-6P zone to its previous zone or other appropriate zone may be filed by the Commission as provided under Article 6 herein above.

The final development plan shall show the information as specified by Article 21: Development Plans. The Commission shall approve, conditionally approve, or disapprove a final development plan within ninety (90) days after the applicant submits his development plan.

12-10(c) BUILDING PERMIT REQUIRED - No building permit shall be issued until a final development plan has been approved by the Commission and certified to the Division of Planning, after which a permit for construction may be issued by the Division of Building Inspection. The approved final development plan shall limit and control the issuance of all building and occupancy permits, and shall restrict the construction, location, and use of all land and structures to all conditions set forth in the plan. Amendments to the plan can be made only as permitted in Article 21: Development Plans.

Section 7 – That Article 15 of the Zoning Ordinance of the Lexington-Fayette

Urban County Government be and hereby is amended, in part, to read as follows:

GENERAL REGULATIONS FOR HEIGHTS, YARDS, WALLS, FENCES, PROJECTIONS, ACCESSORY STRUCTURES and INFILL/REDEVELOPMENT CONSTRUCTION

15-1 HEIGHTS

15-1(a) MAXIMUM - Except as provided below, no building or structure (or part thereof) shall hereafter be erected or altered to a height greater than the maximum specified for the respective zone.

15-1(b) HOW MEASURED - For the purpose of this Zoning Ordinance, the "height" of a wall of a structure (or any part of a building) is the mean vertical distance from the established grade in front of the lot or the average grade at the base of the front façade of the building, whichever is higher, to the average height of the top of the cornice of a flat roof or roof line; to the deck line of a mansard roof; or to the middle of the highest

gable or dormer in a pitched or hipped roof. If there are no gables or dormers, the "height" of a wall shall be to the middle of such pitched or hipped roof.

On a through lot, where the established grade differs on each street or alley, and it abuts on two or more streets or alleys of different established grades at the front of the lot, the higher grade shall control only for a depth of one hundred twenty (120) feet, measured perpendicularly back from the line of the higher street or alley.

On a corner lot, the height is the mean vertical distance from the average grade at the base of the building on the street of greatest width. If two or more such streets are of the same width, and one is at a higher elevation, it shall be from the highest of such grades. The height limitations, as controlled by the wider street, shall govern for a distance of one hundred twenty (120) feet, measured at right angles back from such wider street, unless parts of the one hundred twenty (120) feet are within a more restricted height zone.

15-1(c) EXCEPTIONS TO HEIGHT LIMITS - Notwithstanding other regulations in this Article, or the maximum specified for the respective zone, the height limits of this Zoning Ordinance shall not apply to the following:

- (1) Barns, silos, or other farm structures on farms; church spires, belfries, cupolas, and domes, not for human occupancy; monuments, water towers, observation towers, transmission towers, windmills, chimneys, smokestacks, derricks, conveyors, flag poles, radio towers, masts and aerials.
- (2) Bulkheads, elevator penthouses, water tanks, monitors and scenery lofts; provided that such structures shall not have an aggregate area greater than twenty-five percent (25%) of the lot area; and provided that no linear dimension of any such structure shall exceed fifty percent (50%) of the corresponding street lot line frontage if the structure is within twenty-five (25) feet of such street lot line.
- (3) Monuments or towers, including fire towers; hose towers; cooling towers; grain elevators; sugar refineries; gas holders; and other structures shall have no height limits where the manufacturing process requires a greater height; provided, however, that all such structures above the limiting heights specified in this Zoning Ordinance shall not occupy more than twenty-five percent (25%) of the area of the lot, shall be distant at least twenty-five (25) feet from every adjoining property line, and shall be set back one (1) foot from the otherwise required setback at the limiting height for each foot of vertical height that the structure exceeds the limiting height.
- (4) Solar heating and solar collection devices, provided such devices are no more than five (5) feet higher than the otherwise permitted maximum height for the zone in which they are located.

15-2 YARDS - Except as otherwise specified herein, every lot shall have a front yard, a rear yard, and a side yard on each side, the least depths of which shall not be less than those specified for the respective zone, or as contained in the small lot provisions for each residential zone.

15-2(a) FRONT YARDS

15-2(a)(1) REQUIRED FRONT YARD FOR REDEVELOPMENT OF A LOT - In any residential zone, whenever a principal structure is destroyed or demolished by any means, any subsequent principal structure on that lot shall be located within ten (10) feet of the same setback as the previous structure, except as provided in the small lot provisions established for each residential zone. Where the setback of the original structure cannot be determined, or if the lot is vacant, the setback of the new structure, including any projections, shall be within ten (10) feet of the average front yard of the principal structures on the two lots immediately adjoining on either side of the subject property, provided those structures are located in the same block front and within one hundred (100) feet of each side of the lot. The front yard shall not be required to exceed the average depth of the front yards of existing buildings on the two lots immediately adjoining, but shall be at least ten (10) feet. In no event shall a building be constructed any closer than the least setback established by the averaging above, or as established on a plat of record.

15-2(a)(2) REQUIRED FRONT YARD FOR BUILDING ADDITIONS - In any residential zone, whenever an addition is made to the primary wall plane of an existing principal residential structure, any addition to that structure shall be located within ten (10) feet of the average front yard of the principal structures on either side of the subject property, provided they are located in the same block front and within one hundred (100) feet of each side of the lot. The front yard shall not be required to

exceed the average depth of the front yards of existing buildings on the two lots immediately adjoining, but shall be at least ten (10) feet. If the lots on either side of the property in question are vacant, then the setback required for the specific zone shall be used to determine the front yard required for any building addition; but in no event shall a building be constructed any closer than the least setback established by the averaging above, or as established on a plat of record.

15-2(a)(3) YARD ON STREET SIDE ON LOT ADJOINING OR FACING A RESIDENTIAL ZONE - On a lot in any non-residential zone sharing the same block front with a lot in any residential zone, the depth of the minimum required front yard shall equal the required front yard depth for that residential zone, or as contained in the small lot provisions for the residential zone.

15-2(a)(4) FRONT YARDS ON THROUGH LOTS - On any lot which runs through a block from street to street, a front yard as otherwise required in the zone shall be provided along each street lot line. In residential zones, the small lot provisions will apply. In the event that one of the streets is an alley, the required front yard along the alley shall be the equivalent of fifty percent (50%) of the otherwise required front yard for the zone in which it is located. Alignment of existing structures shall not be used to determine a building line along a rear alley.

15-2(a)(5) FRONT YARDS NOT PARALLEL TO THE BUILDING - Where the front wall of a building is not parallel with the front lot line or is broken or otherwise irregular, the average depth of the front yard shall not be less than the front yard required for that zone, or as contained in the small lot provisions for residential zones. No wall of a building shall encroach more than five (5) feet into the otherwise required front yard depth.

15-2(a)(6) REQUIRED FRONT YARD FOR INFILL AND REDEVELOPMENT OF LOTS IN BUSINESS ZONES - On a lot in a business zone and inside the Infill & Redevelopment Area, the required front setback (minimum and maximum) of the building shall be within five (5) feet of the average front yard of the principal structures on the two lots immediately adjoining on either side of the subject property, provided those structures are located in the same block front and within one hundred (100) feet of each side of the lot. This setback shall be considered more restrictive than the underlying zone setback when applicable.

15-2(b) SIDE YARDS

15-2(b)(1) SIDE YARDS DECREASED FOR NARROW LOT - For each foot by which an existing lot of record at the time of enactment of this Zoning Ordinance is narrower than fifty (50) feet, and where the owner of record does not own any adjoining property, one and one-half (1½) inches may be deducted from the required least width of any side yard for buildings not exceeding two and one-half (2½) stories in height. In no case may a side yard be narrower than three (3) feet at any point. For any lot within the designated Infill and Redevelopment Area, the special provisions for the Infill and Redevelopment Area contained in Article 8 shall take precedence.

15-2(b)(2) SIDE YARDS INCREASED FOR DEEP BUILDINGS - In any zone where a side yard is required, the least width of each side yard shall be increased by one (1) inch for each foot by which the side wall of a building adjacent to a side yard exceeds fifty (50) feet.

15-2(b)(3) ADDITIONAL YARD REQUIREMENTS FOR CERTAIN MULTI-FAMILY STRUCTURES - In addition to other yard requirements, whenever the principal entrance to a multi-family structure, or the entrance to the individual dwelling units therein, faces on and opens directly onto the side yard portion of the building, that side yard width shall not be less than the front yard requirement, or thirty (30) feet, whichever is greater. No parking shall be permitted within the side yard space required under this provision.

15-2(b)(4) SIDE STREET SIDE YARD - On a corner lot in any zone, the required least width of the side street side yard shall equal either the minimum front yard required for that zone or the existing alignment on the lot immediately adjoining, whichever is less. Notwithstanding the above, no such yard shall be required to exceed thirty (30) feet in a residential, business, or industrial zone.

15-2(b)(5) SIDE YARD EXCEPTIONS FOR ATTACHED DWELLINGS - In the case of attached dwelling units, the entire structure shall be considered as a single building with respect to side yard requirements.

15-2(b)(6) SIDE YARDS NOT PARALLEL TO THE BUILDING - Where the side wall of a building is not parallel with the side lot line or is broken or otherwise irregular, the average width of the side yard shall not be less than the otherwise required least

width. At no point shall the side yard be narrower than one-half (½) the otherwise required side yard; nor shall it be narrower than three (3) feet, in any case.

15-2(b)(7) SIDE YARD FOR AN ADDITION TO AN EXISTING BUILDING - On any lot in a residential zone, where the principal structure does not meet the minimum required side yard for that zone, if the side yard is legally non-conforming, additions to the principal structure may be made which have the same side yard as the original structure. In no case shall the addition be closer than three (3) feet to the adjoining lot line. All provisions of Section 15-2(b)(2) regarding increased side yards for deep buildings shall apply.

15-2(c) REAR YARDS - Where the rear wall of a building is not parallel with the rear lot line or is broken or otherwise irregular, the average depth of the rear yard shall not be less than the otherwise required rear yard; provided, however, that such rear wall shall not at any point encroach any more than one (1) foot into the otherwise required rear yard.

15-3 YARD REQUIREMENTS ADJOINING A MORE RESTRICTIVE ZONE - Where a property adjoins the side or rear yard of a lot in another zone, the side or rear yard in the zone with the less restrictive yard requirements shall equal the adjoining side or rear yard (as appropriate) of the zone with the more restrictive yard requirements.

15-4 WALLS AND FENCES

15-4(a) BARBED WIRE / ELECTRIC FENCING - No barbed wire or electric fences shall be permitted within either a residential zone or a mobile home park zone. No barbed wire shall be permitted along any boundary adjoining a residential zone or a mobile home park zone unless such wire is located at least six (6) feet above ground level. Protective devices utilizing barbed wire may be installed upon walls or fences constructed or used in conjunction with a non-conforming commercial or industrial use in a residential zone. Unless otherwise prohibited by this section, barbed wire shall be permitted in all professional office, business, and industrial zones.

15-4(b) HEIGHT – The maximum height of walls and fences shall be regulated in accordance with the following table:

<u>Zone</u>	<u>Maximum Height</u>
1. Any residential or office zone; any business zone other than B-2, B-2A, B-2B or B-4.	<p>a. Between any public or private street right-of-way and the front plane of the building, except an alley: 4 feet, with the following exceptions:</p> <ol style="list-style-type: none"> 1. Where the front or side street side yard abuts an alley: 8 feet. 2. Where the property is a double-frontage lot, the frontage abutting an arterial highway or collector street where driveway access is prohibited (e.g., New Circle Road, Man o' War Boulevard, etc.): 8 feet. <p>b. Side or rear yard (behind the front plane of the building): 8 feet.</p> <p>c. Any side street side yard abutting a street other than an alley, within 3 feet of the public or private right-of-way: 4 feet; greater than 3 feet from the right-of-way: 6 feet.</p>

2. Any B-2, B-2A or B-2B zone	a. Front yard: 6 feet. b. Side or rear yard: 8 feet.
3. Any agricultural, B-4 or Industrial zone	a. No limitation

For the purpose of this section, the height of a wall or fence shall be the vertical distance from the established grade at the fence or wall to the top of the fence or wall.

15-4(c) FENCE ORIENTATION ABUTTING PUBLIC PROPERTY - In all zones other than agricultural zones, where fencing is located adjacent to a public street, park or other publicly owned property, the fencing shall be installed with the structural members or framing directed inward toward the property.

15-5 PROJECTIONS

15-5(a) COVERED PORCHES, STAIRWAYS, TERRACES - Covered porches, stairways, terraces or other similar features, the floor level of which is not over three (3) feet above the established grade and does not extend above the level of the first floor of the building, when open and unenclosed, may project into a required front, side or rear yard no more than eight (8) feet; provided that such covered porches, stairways, terraces, or other similar features conform to the provisions of Section 15-5(d). Ramps providing handicap access for mobility purposes shall be permitted to extend into any required yard, to the extent necessary to further the goals of the Americans with Disabilities Act.

15-5(b) OUTSIDE STAIRWAYS - Outside stairways may extend up to (3) feet into any required side yard, provided the projection is at least three (3) feet from all lot lines; however, they may not extend more than five (5) feet into any required rear yard.

15-5(c) CHIMNEYS AND ORNAMENTAL FEATURES - Flues, belt courses, leaders, sills, lintels, ornamental features, cornices, eaves, gutters and the like, may not extend more than twenty-four (24) inches into any required yard. Chimneys and pilasters may extend up to twenty-four (24) inches into any required yard, provided they are at least three (3) feet from all lot lines.

15-5(d) MAXIMUM PROJECTION - Notwithstanding any other provision of this section, no projection, as listed above, shall extend into any required side yard more than one-half ($\frac{1}{2}$) the width of such yard, nor within ten (10) feet of the front lot line, within five (5) feet of the rear lot line, nor within three (3) feet of any accessory building. Such limitations shall not apply to terraces and steps inside yards, or to a loading dock or tailboard in connection with an industrial siding.

15-6 LOCATION, HEIGHT AND SIZE OF ACCESSORY BUILDINGS

15-6(a) LOCATION AND HEIGHT - The following provisions shall regulate the location and height of accessory buildings with respect to required yards:

- (1) Accessory buildings shall be prohibited in any required front yard or side street side yard.
- (2) Accessory buildings shall be distant at least six (6) feet from alley lines.
- (3) In any zone requiring a side yard or rear yard, the accessory building shall be distant at least one and one-half ($1\frac{1}{2}$) feet from any adjoining lot line. Where any portion of an accessory building projects between a principal structure and the side lot line, the accessory building shall comply with the side yard restriction for a principal structure in the zone in which it is located. Where a principal structure is later expanded to project past the front wall of an accessory structure, the accessory structure may remain at least one and one-half ($1\frac{1}{2}$) feet from any adjoining lot line.
- (4) The maximum height of accessory buildings shall be measured from the grade surrounding the structure to the apex of the gable and shall not exceed the elevation of the principal structure. In no case shall an accessory building exceed twenty (20) feet in height, measured at mid-gable.
- (5) Where a corner lot adjoins in the rear a lot in any residential zone, no part of an accessory building shall extend closer to the street than the actual or required

(whichever is less) depth of the front yard for the principal structure on an adjoining lot.

15-6(b) MAXIMUM HEIGHT RESTRICTION IN NON-RESIDENTIAL ZONES - Accessory buildings in non-residential zones shall not exceed the maximum height restriction for the zone in which they are located.

15-6(c) MAXIMUM HEIGHT AND SIZE IN RESIDENTIAL ZONES - Accessory buildings in residential zones shall not exceed the lot coverage (building footprint) of the building(s) to which they are accessory, nor shall the maximum height of accessory buildings in residential zones exceed the requirements of Section 15-6(a)(4). The total size of all buildings accessory to dwelling units shall not exceed fifty percent (50%) of the total square footage of the building(s) to which they are accessory, or six hundred twenty-five (625) square feet, whichever is greater.

15-7 GENERAL REGULATIONS FOR INFILL AND RE-DEVELOPMENT CONSTRUCTION

15-7(a) NEW RESIDENTIAL CONSTRUCTION - All new residential structures and additions to the primary wall plane within defined Infill and Redevelopment Areas shall be subject to the following requirements:

- (1) A primary entrance for pedestrian access into each building shall be provided along the primary wall plane or its offsets.
- (2) A one-story projection on the primary wall plane of a building shall be provided and shall include at least one of the following:
 - a. A porch, a minimum of twelve (12) inches high, four (4) feet in depth and width; or
 - b. A canopy over the primary entrance, a minimum of three (3) feet in depth and width; or
 - c. A bay window, projecting a minimum of one (1) foot and being three (3) feet in height; or
 - d. A recessed entry, a minimum of three (3) feet in depth and four (4) feet in width that includes exterior steps, or an arched doorway.
- (3) A minimum of ten percent (10%) of the primary wall planes and side wall planes facing a public street shall be transparent glass, or any window or person door opening; but shall not exceed the maximum openings permitted under the Kentucky Building Code. Garage doors shall not be calculated in the wall plane area.
- (4) Garage doors located anywhere from four (4) feet behind the primary wall plane to the lot frontage shall be subject to at least one of the following criteria:
 - a. A garage door facing the lot frontage shall not exceed thirty percent (30%) of the surface of the building façade; or
 - b. The garage door shall be located a minimum of four (4) feet behind the primary wall plane; or
 - c. The garage door shall be perpendicular to the lot frontage.

15-7(b) GROUP RESIDENTIAL PROJECTS - In addition to the requirements in Article 15-7(a), all Infill and Redevelopment Group Residential Projects shall be subject to the following requirements:

- (1) The choice of garage door location under Article 15-7(a)(4)(b) shall not be permitted.
- (2) At least seventy-five percent (75%) of the roof surface of the principal structure shall be covered by a minimum 4:12 pitched roof.
- (3) The maximum length of a primary wall plane for a structure shall be 160 feet.
- (4) A change of at least four (4) feet in depth and at least eight (8) feet in length shall occur for every forty (40) feet in a primary wall plane or side wall plane facing a public street.
- (5) All exterior lighting shall require a lighting cutoff, concealing the source of lighting visible from all property lines of the site.
- (6) The maximum height of freestanding exterior lighting fixtures shall be twenty-five (25) feet.

15-7(c) CONFLICT OF INFILL STANDARDS WITH DESIGN GUIDELINES IN A LOCAL HISTORIC (H-1) DISTRICT - In the event the provisions of Sections 15-7(a) and (b) above would conflict with the adopted Design Guidelines applied by the Board of Architectural Review as a part of the Certificate of Appropriateness review and approval process, the H-1 guidelines shall be deemed to be the stricter requirement and shall control.

15-7(d) SPECIAL CONSIDERATIONS FOR SET-BACKS IN INFILL AND REDEVELOPMENT AREAS - The intent of the Infill and Redevelopment regulations is to allow new construction that is compatible with existing development patterns in older,

established neighborhoods. Unique circumstances may require appropriate Board of Adjustment action to allow some relief of yard requirements where strict application of the regulations would cause unusual hardship or a development incompatible with the existing pattern of the neighborhood.

15-8 GENERAL REGULATIONS FOR LOCATION, HEIGHT AND SIZE OF SATELLITE DISH ANTENNAS - Satellite dish antennas shall be permitted in all zones and shall be subject to the following provisions regulating location, height and size:

- a. All roof and pole-mounted satellite dish antennas greater than six (6) feet in diameter shall be of the mesh type only, with not more than eighty-five percent (85%) of the surface being solid, and shall be painted a solid dark color.
- b. When located in an agricultural zone, satellite dish antennas shall be limited to:
 - (1) One (1) per lot, for lots of ten (10) acres or less; for over ten (10) acres, no limit as to the number;
 - (2) A maximum diameter of twelve (12) feet;
 - (3) A maximum height of four (4) feet above the highest point of the principal building on the lot;
 - (4) Shall be for private non-commercial use only and shall be accessory to a principal use on the property;
 - (5) Shall not be visible from the road or from adjoining property, and shall be screened with landscaping material.
- c. When located in any residential zone, satellite dish antennas shall be limited and regulated as follows:
 - (1) Satellite dish antennas shall be prohibited in any required front yard;
 - (2) For single family, duplex and townhouse dwellings, one (1) per dwelling unit;
 - (3) For multi-family dwellings, one (1) per multi-family building;
 - (4) For all other uses permitted in the residential zones not specifically provided for otherwise (e.g., schools, places of religious assembly, nursing homes, etc.), one (1) per building;
 - (5) The maximum diameter of any satellite dish antenna shall be twelve (12) feet;
 - (6) The maximum height of any portion of the satellite dish antenna shall be four (4) feet above the highest point of the principal building on the lot, regardless of the height of the structure or the maximum height restriction in the zone;
 - (7) All satellite dish antennas shall be for private non-commercial use only and shall be accessory to a principal use on the property.
- d. When located in a business, office, or industrial zone, satellite dish antennas shall have no restriction as to location, height, size or number per lot.

Section 8 – That Article 16 of the Zoning Ordinance of the Lexington-Fayette

Urban County Government be and hereby is amended, in part, to read as follows:

GENERAL REGULATIONS FOR PARKING, LOADING AREAS, GARAGES, AUTOMOBILE SERVICE STATIONS, VEHICLE SALES LOTS AND STACKING AREAS

16-1 GENERAL REGULATIONS FOR PARKING, LOADING AND PEDESTRIAN AREAS

16-1(a) PARKING OR LOADING SPACES ESTABLISHED PRIOR TO ADOPTION OR AMENDMENT OF THIS ZONING ORDINANCE - Any parking or loading spaces established prior to the adoption or amendment of this Zoning Ordinance that are either used or are intended to be used in connection with any principal building, structure, or use; or any spaces designed and intended to comply with the requirements of this Zoning Ordinance for any such principal building or structure erected after that adoption or amendment date, shall hereafter be maintained, as long as said building, structure, or use remains (unless the owner provides and maintains, in another location, an equivalent number of spaces as required in conformance with the provisions of this Zoning Ordinance).

16-1(b) PARKING REQUIREMENTS FOR A CHANGE IN THE PRINCIPAL USE - Where the principal use is changed to a use for which additional parking space is required under the provisions of this Zoning Ordinance, it shall be unlawful to begin or maintain such altered use until the required off-street parking is provided.

16-1(c) UNITS OF MEASUREMENT FOR DETERMINING THE REQUIRED PARKING

- For the purpose of this Zoning Ordinance, "floor area" as used in computing the required off-street parking or loading areas, shall mean "Parking Floor Area" as defined in this Zoning Ordinance. In stadiums, sports arenas, places of religious assembly, or other places of assembly where patrons or spectators occupy benches, pews, or other such seating facilities, each 24 inches of such seating facilities shall be counted as one seat for the purpose of determining the requirements for off-street parking spaces under this Zoning Ordinance. When units of measurement used in determining the number of required parking spaces would result in the requirement of a fractional space, any fraction less than one-half ($\frac{1}{2}$) shall be disregarded, and fractions of one-half ($\frac{1}{2}$) or more shall require one (1) parking space.

16-1(d) LOCATION OF PARKING SPACES

- The location of parking spaces shall be as hereinafter set forth; and where distances are specified, they shall be the walking distances measured from the nearest point of the parking facility to the nearest point of the building that such facility is required to serve. For one and two-family dwellings, parking shall be provided on the same lot with the building it is required to serve; for multiple family dwellings, not more than 200 feet from the building the parking spaces are required to serve; for uses located in or permitted in a Professional Office or any business zone (except B-2B); and for hospitals, nursing, convalescent and personal care facilities, orphanages, private clubs, fraternity or sorority houses, and places of religious assembly, not more than 300 feet from the building they are required to serve; for uses located in or permitted in any industrial zone and uses not specified above, not more than 700 feet from the building, or other place of assembly, they are required to serve; and for all uses located in the B-2B zone, on any lot located within the B-2, B-2A, or B-2B zones, parking location shall be subject to the qualifications listed under the requirements of the B-2B zone.

16-1(e) LOADING AND UNLOADING SPACES REQUIRED

- In any zone, every building or part thereof hereafter erected, with a floor area of 10,000 square feet or more, which is to be occupied by manufacturing; com- pounding; processing; storage; warehousing; goods display; retail store; wholesale store; hotel; hospital; funeral parlor; laundry; dry cleaning; or other uses similarly requiring the receipt or distribution by vehicles of material, objects, or merchandise, there shall be provided and maintained on the same premises with such building at least one (1) off-street loading space plus one (1) additional off-street loading space for each 20,000 square feet or fraction thereof of floor area so used in excess of 20,000 square feet.

16-1(f) PERMIT REQUIREMENT

- Permits are required for private walkways, parking, loading or unloading areas. Such permits shall not be issued until the applicant has met the design standards jointly promulgated by the Division of Traffic Engineering and the Division of Building Inspection, the storm drainage requirements of the Division of Engineering, and all other requirements of this Zoning Ordinance.

16-2 MINIMUM DESIGN AND MAINTENANCE REQUIREMENTS FOR PARKING AREAS

- Every parcel of land hereafter used as a parking area shall be designed and maintained in accordance with the following requirements:

- (a) Off-street parking areas shall equal or exceed the number of spaces required, shall be of useable shape and surface, and shall have convenient ingress and egress. Not less than seventy-five percent (75%) of the total required parking spaces shall be designed for use by full-size vehicles. Up to twenty-five percent (25%) of the required parking may be designed and designated for compact vehicles. Aisles and access drives shall be designed so as to provide adequate vehicular maneuvering wholly upon the property being served; and in no case shall off-street parking areas be permitted that encourage or require the backing onto, or maneuvering within, the right-of-way of any public or private street.
- (b) Any lighting used to illuminate off-street parking areas shall be arranged so as to reflect away from any adjoining residential zone or uses and any public or private right-of-way.
- (c) Any off-street parking area having more than 1,800 square feet of area and/or used by five (5) or more vehicles shall be landscaped and screened as required by Article 18: Landscape and Land Use Buffers.
- (d) A "sight triangle" shall be observed at all street intersections or intersections of driveways with streets as required in Article 18: Landscape and Land Use Buffers and Section 3-3 of this Zoning Ordinance.
- (e) All parking areas shall be paved and drained so as to dispose of all surface water within the parking area without carrying said water accumulation over a public sidewalk. Piping the water to a suitable outfall may be required.
- (f) Where parking areas are provided for five (5) or more vehicles or contain more than 1,800 square feet of area in a residential zone; or are enlarged or expanded to provide for five (5) or more vehicles or to contain more than 1,800 square feet of area, they shall be paved with an asphalt, concrete, brick or other properly bound surface, so as to be durable and dustless. Each parking space shall be physically delineated on the surface of the parking area.

- (g) Permanent storm water management, in compliance with the storm water manuals and accepted by the Division of Engineering, shall be provided for all off-street parking areas containing five (5) or more parking spaces and/or more than 1,800 square feet. For off-street parking areas of 1,800 square feet or less, or less than five (5) parking spaces, permanent storm water retention may be required by the Division of Engineering upon the determination that the lack of such retention would cause or aggravate flooding or other drainage problems on surrounding property.

16-3 REQUIRED PROFESSIONAL OFFICE OR BUSINESS (EXCEPT B-2B) ZONE AUTOMOBILE PARKING AREA AS A CONDITIONAL USE IN R-3, R-4 or R-5 ZONE -

The establishment and operation of a restricted accessory parking area may be authorized by the Board of Adjustment as a conditional use in such parts of any Planned Neighborhood Residential (R-3) zone, High Density Apartment (R-4) zone or High Rise Apartment (R-5) zone as abut, either directly or across an alley, a Professional Office or business (except B-2B) zone or any conforming or non-conforming institutional use in a particular residential zone, subject to the following conditions and requirements:

- (a) The parking area shall be accessory to and for use in conjunction with one or more permitted uses located on an adjoining Professional Office or business (except B-2B) zone, or in connection with one or more existing conforming or non-conforming institutional uses on adjoining premises.
- (b) Such parking shall be situated on premises not less than 5,000 square feet in area which shall abut at least fifty (50) feet, either directly or across an alley, on a Professional Office or business (except B-2B) zone, or on the premises of the existing conforming or non-conforming institutional use to which the parking area is accessory.
- (c) Such parking area shall be used solely for the parking of passenger automobiles. No commercial repair work or service of any kind shall be conducted, and no charge shall be made for parking. No sign of any kind, other than designating ownership, entrances, exits, and conditions of use, shall be maintained on such parking area. Such signs shall conform to the zone in which the parking area is established.
- (d) Each entrance and exit to and from such parking area shall be at least twenty (20) feet distant from any adjacent lot line located in any residential zone.
- (e) The parking area shall be subject to all requirements of this Zoning Ordinance concerning surfacing, lighting, landscaping, screening, and minimum yards and setbacks.
- (f) Any permit issued by the Division of Planning for such parking area may be revoked any time that the aforementioned requirements are not complied with; and any permittee who uses the premises in violation of any of the conditions specified above, or attached as conditions to such permit by the Board of Adjustment, shall be deemed in violation of this Zoning Ordinance.

16-4 PARKING, LOADING AND UNLOADING AREAS IN RESIDENTIAL ZONES

16-4(a) MINIMUM REQUIRED PARKING - In every R-1A, R-1B, R-1C, R-1D, R-1E, R-1T and R-2 zone, there shall be provided at least one (1) off-street parking space for each dwelling unit; no such space shall be located within any required front yard or side street side yard area. The parking area and driveway shall be paved with concrete, asphalt, brick or other suitable hard surface materials, as approved by the Division of Building Inspection. Loose aggregate or other type of gravel is prohibited, except as approved by the Board of Architectural Review for the purpose of historic preservation, or when approved by the Urban County Forester for the purpose of tree protection. In either case, the applicant must show that there is not another reasonable alternative to the loose aggregate. Where decorative rock, or a similar product, is being driven on or being used for parking, it shall be considered loose aggregate and prohibited.

Any private walkway shall be designed in such a way that a vehicle cannot drive on it so as to permit the area to be used as a parking space or vehicular use area. No private walkways shall be built in the street right-of-way without approval of an encroachment permit.

Within the defined Infill & Redevelopment Area, the maximum width in the front yard of any driveway serving the required space(s) per dwelling unit shall be limited to ten (10) feet.

16-4(b) ADDITIONAL PARKING - Provided the above parking has been met, additional parking shall be permitted in any R-1A, R-1B, R-1C, R-1D, R-1E, R-1T or R-2 zone, provided the following requirements are met:

- (1) The parking area and driveway shall be paved with concrete, asphalt, brick, grass pavers, or other suitable hard surface materials as approved by the Division of Building Inspection. Loose aggregate or other type of gravel is prohibited, except

as approved by the Board of Architectural Review for the purpose of historic preservation, or when approved by the Urban County Forester for the purpose of tree protection. In either case, the applicant must show that there is not another reasonable alternative to the loose aggregate. Where decorative rock, or a similar product, is being driven on or being used for parking, it shall be considered loose aggregate and prohibited.

Any private walkway shall be designed in such a way that a vehicle cannot drive on it so as to permit the area to be used as a parking space or vehicular use area. No private walkways shall be built in the street right-of-way without approval of an encroachment permit.

(2) The paved areas for parking areas and driveways shall be set back from the property lines as follows:

Zone	Setback from Front Lot Line and/or Side Street Line		Setback from Side & Rear Lot Line	
	and/or Side Street Line	Side Lot Line	Rear Lot Line	Side Lot Line
R-1A	15'		8'	
R-1B	10'		4'	
R-1C	6'		2'	
R-1D	6'		2'	
R-1E	6'		2'	
R-1T	6'		2'	
R-2	6'		2'	
R-3 & R-4*	6'		2'	

* For single family homes or duplexes, per Article 16-4(c)(6)

- (3) a. If located within the required front yard or required side street side yard, outside the defined Infill and Redevelopment Area, the percentage of coverage of parking areas and driveways shall not exceed fifty percent (50%) of the total required front or side street side yard. The maximum amount of paved area, including private walkways, shall not exceed sixty percent (60%) of the total required front or side street side yard.
- b. If located within the required front or side street side yard, inside the defined Infill and Redevelopment Area, parking is prohibited, and driveway width shall be limited to ten (10) feet. The maximum amount of private walkways shall not exceed ten percent (10%) of the total required front or side street side yard.
- (4) The design of the parking areas and driveways shall be developed so as to discourage the backing of vehicles onto a public right-of-way.
- (5) The parking area shall be landscaped and screened as required by Article 18 of this Zoning Ordinance.
- (6) A permit shall be required for the construction of all parking areas and driveways that fall under the above regulations. The owner must provide the Division of

Building Inspection with a plot plan showing the entire lot, the location of the residence, the layout of the parking areas and driveways (both the required spaces and proposed extra spaces) and all proposed landscaping and screening required, as well as any other information necessary to clearly define the proposed construction as required by the Division of Building Inspection.

- (7) Within the defined Infill and Redevelopment Area, the maximum number of parking spaces on the lot will be no more than fifty percent (50%) additional spaces over the required parking. The following table gives examples of the required and maximum number of parking spaces:

Required Parking	Maximum Parking
1	2
2	3
3	5
4	6

- (8) Properties that have one or more street frontage with restricted parking shall be allowed one (1) additional parking space per restricted street frontage over the maximum allowed parking.

16-4(c) PARKING, LOADING, AND UNLOADING PROHIBITED IN RESIDENTIAL ZONES R-3, R-4 and R-5 - In the R-3, R-4 and R-5 residential zones, parking, driveways, loading and unloading areas must meet the following requirements:

- (1) No off-street parking area, loading or unloading area, maneuvering area or aisles shall be permitted within the required front yard or side street side yard of any lot with a principal building. Where parking is the principal use of a lot, such off-street parking, loading or unloading area shall not be closer to any lot line than the distance required for a principal building of one (1) story in height.
- (2) No portion of the front yard or side street side yard, exclusive of driveways, shall be paved or surfaced; and all such front and side street side yards shall be enclosed by a barrier, or landscaped in such a manner, suitable to preclude any such activity as prohibited in this section.
- (3) The parking area and driveway shall be paved with concrete, asphalt, brick or other suitable hard surface materials, as approved by the Division of Building Inspection. Loose aggregate or other type of gravel is prohibited, except as approved by the Board of Architectural Review for the purpose of historic preservation, or when approved by the Urban County Forester for the purpose of tree protection. In either case, the applicant must show that there is not another reasonable alternative to the loose aggregate.
- (4) Within the defined Infill & Redevelopment Area, the maximum number of surface parking spaces on the lot will be no more than fifty percent (50%) additional spaces over the required parking. [See the table in Section 16-4(b)(7) for examples].
- (5) Properties that have one or more street frontage with restricted parking shall be allowed one (1) additional parking space, over the maximum allowed parking, per restricted street frontage.
- (6) For a single family detached dwelling unit, or a two-family duplex unit in the R-3 or R-4 zone, the parking requirements shall be as per Articles 16-4(a) and 16-4(b).

16-4(d) NON-CONFORMING PARKING EXCEPTION

- (1) No off-street parking space shall be required for a single family detached residence on any lot redeveloped as defined in Article 15-2(a)(1) when the lot already has no off-street parking space (a non-conforming situation).
- (2) No off-street parking space shall be required within the defined Infill and Redevelopment Area where the Urban County Council has established a designated on-street parking area on a block-by-block basis.

16-5 PARKING, LOADING AND UNLOADING AREAS PERMITTED IN REQUIRED FRONT OR SIDE STREET SIDE YARD IN ZONES OTHER THAN RESIDENTIAL ZONES - In any zone other than a residential zone, or an industrial zone adjoining an Agricultural Rural (A-R), Agricultural Buffer (A-B) or Agricultural Natural (A-N) zone across a public or private street right-of-way, off-street parking, loading or unloading areas may be permitted within the required front or side street side yard if there is sufficient depth between the street right-of-way line and the building line or other barrier to accommodate

all parking and maneuvering without the necessity of backing over the street right-of-way line. All portions of front yards and side street side yards, including driveways, shall be enclosed by a barrier or landscaped in accordance with the landscaping requirements for vehicular use areas set forth in Article 18 of this Zoning Ordinance.

16-6 SINGLE PARKING AREAS FOR MULTIPLE USES - The required off-street parking for any number of separate uses may be combined in one lot; but the off-street parking required by any use for the purposes of complying with this Zoning Ordinance shall not be counted, nor shall it be included in the off-street parking required for any other use unless specifically permitted herein.

16-7 JOINT USE OF PARKING AREAS - The Division of Planning may, upon application by all parties involved, authorize the joint use of off-street parking facilities. Joint use of off-street parking shall be subject to the following limitations and conditions:

- (a) Off-street parking areas required for detached single family and two family residential use shall not be included in any joint parking arrangement. For the purpose of this Article, residential uses shall be considered between the hours of 7 p.m. and 7 a.m.
- (b) Up to one hundred percent (100%) of the off-street parking required for a place of religious assembly, or an auditorium incidental to a public or private school; and up to seventy-five percent (75%) of the off-street parking required for any other use may be provided by a joint parking arrangement.
- (c) The joint parking area shall be within 300 feet of all of the uses being served by such facility, measured by the walking distance from the nearest point of the parking facility property to the nearest point of the property where the use is located and which the parking is intended to serve.
- (d) The applicant shall submit sufficient data to the Division of Planning to demonstrate that the normal and regular operating hours of the uses proposing a joint parking arrangement do not coincide or overlap by more than one (1) hour.
- (e) All parties shall execute a properly drawn legal instrument for the joint use of off-street parking areas. This instrument, having been approved as to form and manner of execution by the legal counsel of the Lexington-Fayette Urban County Government, shall be filed with the application.

16-8 SPECIAL ACCESS, SURFACE, AND LOCATION REQUIREMENTS FOR GARAGES, PARKING LOTS, AUTOMOBILE SERVICE STATIONS, AND VEHICLE SALES LOTS

16-8(a) REQUIRED DISTANCE BETWEEN SERVICE STATIONS/GARAGES/AUTOMOBILE REPAIR SHOPS/ AUTOMOBILE & VEHICLE REFUELING STATIONS AND RESIDENTIAL ZONES AND/OR INSTITUTIONAL USES - No building, structure or premises intended or designed to be used as a community garage; an automobile repair shop; a service station; an automobile and vehicle refueling station or a parking lot or structure, whether a principal or a conditional use on a property, shall be used, erected or altered, which has an entrance or exit for vehicles in the same block front and within 200 feet of the property boundary of any school; public playground; place of religious assembly; hospital; public library; convalescent home, nursing home or personal care facility or orphanage. No such entrance or exit, except for a community garage, shall be located within twenty (20) feet of any residential zone; nor shall any structure used for an automobile repair shop or service station, or any part of a parking lot or structure, be located within 100 feet of any property boundary line of any of the aforesaid public or institutional uses. "Parking lot," as used herein, does not include off-street parking areas as otherwise required for the public or institutional uses listed above.

16-8(b) REQUIRED DISTANCE BETWEEN GASOLINE/OIL DISPENSING FACILITIES AND RESIDENTIAL ZONES/USES - No gasoline pump, oil draining pit, or similar appliance for any purpose shall be located within fifteen (15) feet of any right-of-way line, or within fifty (50) feet of a residential zone, except where such a pump, pit or appliance is within a completely enclosed building and distant at least fifteen (15) feet from any vehicular entrance or exit of such building. Notwithstanding the above provision, no gasoline pump, oil draining pit, or similar appliance for any purpose shall be located within 65 feet of a single family residential zone or within 65 feet of a single family detached residential unit located in any residential zone. However, such 65-foot dimension shall not be applicable to the renovation, reconstruction, redevelopment, or construction of such a service station upon a tract used by such a facility within twelve (12) months prior to the application for a building permit. Except for gasoline service stations, no gasoline pump shall be permitted as an accessory use for another activity unless a site plan showing the following is submitted to, and approved by, the Division of Planning:

- (1) A safe traffic flow pattern shall exist at all times for vehicles to be serviced with gas, including a safe entrance and exit to the service area, and a traffic flow lane not impeded by parked vehicles or other objects.
- (2) A safe traffic pattern shall exist for pedestrians to insure that pedestrian flow for other purposes is not routed by the gasoline pumps, thereby exposing such pedestrians to unnecessary hazards.
- (3) The gasoline pumps shall be operated only by employees of the activity; or if others are permitted to operate them, the facility must comply with Chapter 28 of the Kentucky Fire Prevention Code, specifically Section F-2803.8.2 and Section F-2803.8.3.

16-8(c) REQUIRED DISTANCES BETWEEN AUTOMOBILE AND VEHICLE REFUELING STATIONS DISPENSING COMPRESSED NATURAL GAS AND/OR LIQUID NATURAL GAS AND OTHER USES - In addition to the requirements of this section (above), no stationary dispensing equipment for compressed natural gas or liquid natural gas associated with an automobile and vehicle refueling station may be located within:

- (1) 10 feet of any sidewalk, walkway, parking lot or property line;
- (2) 15 feet of any electrical source or any overhead electric utility line;
- (3) 50 feet of a right-of-way line, a building on another lot, or the nearest rail of any railroad line;
- (4) 65 feet of a residential zone; and
- (5) not less than 50 feet of a fire hydrant.

16-8(d) REQUIREMENTS FOR VEHICLE SALES LOTS - Every parcel of land hereafter used as an automobile, truck, mobile home, boat, trailer, or camper sales lot, or as an automobile service station shall be subject to the requirements of this Zoning Ordinance concerning surfacing, lighting, landscaping and screening, and minimum yards and setbacks; and shall be considered, in the application thereof, as the equivalent of a parking area for more than five (5) vehicles, regardless of its size.

16-8(e) COMMUNITY GARAGES AS CONDITIONAL USES - Community garages permitted as a conditional use in a R-3 and R-4 zone shall not be within 80 feet of any right-of-way line or in a R-3 zone be within 25 feet of any other lot line; or in a R-4 zone be within 20 feet of any lot line, except the rear lot line of an adjoining Professional Office, Business or Industrial zone.

16-9 STACKING AREA - For any use which utilizes a drive-in or drive-through window or service area, a vehicular stacking area shall be provided for a minimum of five (5) vehicles. Such vehicular stacking area shall not include any spaces located at the windows or service areas, shall be provided wholly on the property and shall not include any right-of-way. Where menu boards or other stopping points are utilized before moving to the window or service area, the vehicular stacking area shall not include the space at the stopping point nor the spaces between that stopping point and the window or service area. The vehicular stacking area shall be subject to all yard, paving, landscaping and other requirements of a vehicular use area, as contained in Article 18.

16-10 REDUCTIONS OF MINIMUM REQUIRED PARKING - All parking reductions shall apply only under the following circumstances:

- (1) Uses shall be limited to attached single family dwellings and multi-family dwellings in residential and/or mixed use zones.
- (2) Properties in the P-1 and B-1 zones, when located within the Infill & Redevelopment Area, are eligible.
- (3) Properties in the B-3 or B-6P zone, when required to meet the provisions of Article 12-8 herein, are eligible for parking reductions.
- (4) The Planning Commission must approve the specific proposed use of the property on a development plan.
- (5) The total maximum amount of parking reductions, including the on-street parking provision of the Mixed Use zones, shall not exceed a fifteen percent (15%) reduction of the otherwise required parking, unless the Board of Adjustment grants a parking variance allowable under Article 7.

16-10(a) ALLOWABLE BICYCLE REDUCTIONS - Sites having fifty (50) or more parking spaces may reduce the total minimum automobile parking space requirement by one (1) parking space for every one (1) bicycle space provided on a permanently constructed bicycle rack. The maximum reduction of required parking spaces shall not be reduced less than five percent (5%) of the otherwise required amount. Only the provision of additional bicycle spaces shall count toward this reduction when a minimum

bicycle space is required. Provision of bicycle spaces shall not count against the otherwise required minimum for the calculation of the maximum parking allowed.

16-10(b) ALLOWABLE TRANSIT STOP REDUCTIONS - Sites located within 300 feet of a transit stop with a shelter may be allowed a ten percent (10%) reduction of the minimum required parking. Sites located within 300 feet of a transit stop without a shelter may be allowed a five percent (5%) reduction of the minimum required parking. If the site is located within 300 feet of more than one transit stop, the maximum reduction allowed will be ten percent (10%) for this specific parking reduction. Provision of a transit stop shall not count against the otherwise required minimum for the calculation of the maximum parking allowed.

In addition, "big-box" developments in any B-3 or B-6P zone may be allowed a ten percent (10%) reduction of the minimum required parking if a designated Park & Ride lot is provided on the site near a transit stop with a shelter (designed to meet the specifications of the Lexington Transit Authority), provided the shelter is directly connected to the entrance of a "big-box" establishment by a sidewalk or designated pedestrian pathway.

16-11 EFFECT OF PEDESTRIAN-ORIENTED BUSINESS DISTRICT - For any such district created under Code of Ordinances Article 18, Chapter XIII, the provisions of the district will take precedence over any off-street parking requirements or related provisions contained in the Zoning Ordinance.

Section 9 – That Article 17 of the Zoning Ordinance of the Lexington-Fayette

Urban County Government is hereby amended to read as follows:

SIGN REGULATIONS

17-1 INTENT - The intent of this Article is to provide sign standards and restrictions which allow for the legitimate needs for identification of agricultural, residential, professional office, business, and industrial activities while at the same time promoting signage which does not unduly detract from the overall aesthetics of the community; which reduces intrusions and protects property values; which provides for improved public safety by minimizing the undue distraction of the motoring public; which provides for the protection and enhancement of the tourist industry by promoting a more harmonious and pleasing community image; which is equitably provided in terms of the nature and scale of the activities to be identified and of non-conforming signs; and which generally enhances and strengthens the economic stability of Lexington-Fayette Urban County.

17-2 SCOPE - The provisions of this Article shall apply to the display, construction, erection, alteration, use, location, and maintenance of all signs within Lexington-Fayette Urban County, and it shall be unlawful hereafter to display, construct, erect, alter, use or maintain any sign except in conformance with provisions of this Article.

Furthermore, it shall be unlawful to alter, maintain, enlarge, use, or display any sign erected or constructed prior to the enactment of this Article except in conformance with this Article. Except as specifically provided, the following shall be exempt from the provisions of this Article:

- (a) Signs which are not visible beyond the boundaries of the lot or parcel upon which they are located and/or from any public thoroughfare or right-of-way.
- (b) Official governmental notices and notices posted by governmental officers in the performance of their duties; governmental signs to control traffic or for other regulatory purposes, or to identify streets, or to warn of danger. Identification or bulletin board signs accessory to governmental buildings or other facilities shall not be exempt from the provisions of this Article.
- (c) The flag, pennant, or insignia of any nation, organization of nations, state, county or city, any religious, civic or fraternal organization, or any educational institution; except when such are used in connection with a commercial promotion or as an advertising device.
- (d) Works of fine art not containing a commercial message and which in no way depict a trademark, logo or phrase meant to represent, identify or advertise a specific product or business.

- (e) Temporary decorations or displays, when such are clearly incidental to and are customarily and commonly associated with any national, local, or religious holiday or celebration.
- (f) Temporary or permanent signs erected by public utility companies or construction companies to warn of danger or hazardous conditions, including signs indicating the presence of underground cables, gas lines, and similar devices.
- (g) Merchandise, pictures, or models of products or services which are incorporated as an integral part of a window display.
- (h) Signs displayed on trucks, buses, trailers or other vehicles which are being operated in the normal course of a business, such as signs indicating the name of the owner or business which are affixed or painted onto moving vans, delivery trucks, contractors' vehicles and equipment, rental trucks and trailers, and the like; provided that such signs are clearly incidental to the use of the vehicle in conjunction with a bona fide business and are not for the purpose of display of signs, and provided that they are parked or stored in areas appropriate to their use as vehicles, and in such a manner and location on the lot so as to minimize their visibility from any street to the greatest extent feasible.

17-3 DEFINITIONS - The following definitions unique to this Article are listed below. The terms to be defined have been grouped according to the specific aspects of sign control to which they pertain in order to provide a clearer understanding of the regulations contained later in this Article.

17-3(a) SIGN - Any writing, pictorial representation, form, emblem, trademark, flag, banner, decoration (including material used to differentiate the sign copy from the background) or any figure which is written, printed, projected, painted, constructed, or otherwise displayed upon or designed into a building, board, plate, canopy, awning, window, vehicle, or upon any object or device which by reason of its form, color, wording, symbol, design, illumination, motion or other characteristic is designed to attract attention to the subject thereof or is used as a means of identification, advertisement, announcement, or of illustrating products.

17-3(b) BASIC SIGN TYPES BY FUNCTION - The following categories of signs are hereby defined based upon the nature of the information they are intended to provide:

(1) ADVERTISING SIGN - A sign which directs attention to a business, product, service or activity generally conducted, sold or offered elsewhere than on the premises where such sign is located.

(2) ATTRACTION BOARD - A sign which contains no permanent copy, either letters or emblems, on which copy is changed manually with changeable letters and which announces special activities on the property.

(3) BULLETIN BOARD - A sign which allows the manual changing of the copy material and is used to notify the public of non-commercial events or occurrences such as religious services, political rallies, civic meetings or similar events.

(4) BUSINESS SIGN - A sign which directs attention to a business, profession, product, activity, or entertainment, sold or offered upon the premises where such sign is located, and may include information as for an identification sign.

(5) CONSTRUCTION SIGN - A temporary sign identifying the project name, the architect, engineer, contractor, financing company, material supplier, or others engaged in work on the construction site on which the sign is located. Leasing information, renderings and similar copy shall also be permitted.

(6) DIRECTIONAL SIGN - A non-commercial sign of an instructional nature, such as "parking," "exit" or "entrance," displayed solely for the convenience of the public, no more than twenty-five percent (25%) of such sign being devoted to the name or logo of the property, business or profession on the site and containing no business advertising, or product trade name identification or listing of any product sold or offered on the premises.

(7) DISTRICT IDENTIFICATION SIGN - Any type of sign or other graphic, located on public or private property, which establishes the identity of a unique and distinct community district by way of its size, configuration, height, location or message; and which has no direct advertising value for any specific business, product or service.

(8) GOVERNMENT SIGN - A temporary or permanent sign erected by any government body for traffic direction, or for designation or direction to any school, hospital, park, historic site or other service, property or facility; provided that such signs not contain business advertising of any kind.

(9) HISTORIC MARKER - A sign or emblem which commemorates or identifies an event, past ownership of property, or age of a building.

(10) INCIDENTAL SIGN - A small sign, not exceeding two (2) square feet each, limited to information and directions related to the permitted use on the lot or building on which the sign is located, and containing no direct illumination as defined in this Article. Examples of incidental signs would include "no smoking," "restroom," "no solicitors," "no trespassing," "self service," "vacancy," credit card acceptance signs, signs indicating hours of business, and similar information.

(11) IDENTIFICATION SIGN - A sign which establishes the identity of a building or building complex by name or symbol or combines name, street address, and/or management and has no direct advertising value.

(12) INFORMATIONAL SIGN - A sign whose copy gives only the time, temperature and/or date through an electronic message display system or by mechanical means (including clocks and thermometers), and provides no advertising of any product or business activity.

(13) LANDMARK SIGN - Any type of sign or other graphic that helps to create a unique location by way of its size, configuration, height, location or message and exhibits distinctive stylistic features.

(14) MENU BOARD - A free-standing or wall-mounted sign primarily designed for the display of menu items and prices for the purpose of placing orders for such items in conjunction with a restaurant utilizing drive-through service.

(15) MENU BOX - A wall-mounted sign, primarily designed for the display of menu items and prices in conjunction with a restaurant.

(16) NAMEPLATE - A wall sign which gives only the name, address, and/or occupation of the occupant(s) of the building on which it is located.

(17) POLITICAL SIGN - A temporary sign supporting the candidacy for office or urging action on any other matter on the ballot of a state, local or national election or referendum.

(18) REAL ESTATE SIGN - A temporary sign indicating only sale, lease or rental of property or buildings on which the sign is erected.

(19) TEMPORARY SIGN - Any sign or advertising display constructed of cloth, canvas, light fabric, cardboard, wallboard, plywood, or other light materials, with or without frames, and/or intended to be displayed for a limited period of time only.

(20) TENANT PANEL - A portion of a free-standing shopping center identification sign that lists or advertises an individual tenant that occupies the site. Tenant panels of the same size and shape may be removed and replaced without a sign permit.

(21) TRACT SIGN - A temporary sign advertising the original sale of property in a subdivision.

(22) A-FRAME or SANDWICH BOARD - A free-standing, movable sign, not secured or attached to the ground or any building or structure, composed of a sign panel and supporting structure or one or more panels which form both the structure and sign face, and which is intended to be placed in a sidewalk or pedestrian way. A-frame signs shall not include trailer signs with or without wheels affixed.

17-3(c) SIGN TYPES BY MEANS OF MOUNTING OR ERECTING - The following categories of signs are hereby defined primarily by the means of mounting or erecting and locational placement upon a building or premises:

(1) AWNING SIGN - A sign painted on or printed on, or attached flat against, the surface of an awning. As used in this Article, awning shall be defined as a shelter supported entirely from an exterior wall of a building consisting of cloth or other similar non-rigid material supported by a frame.

(2) UNDER-AWNING OR UNDER-CANOPY SIGN - A small sign, limited to four (4) square feet, attached to and suspended from the underside of a canopy or awning and having a clearance of not less than eight (8) feet.

(3) CANOPY SIGN - A sign painted, printed or attached flat against a surface of a canopy. As used in this Article, canopy shall be defined as a permanently roofed shelter covering a sidewalk, driveway or other similar area, which shelter may be wholly supported by a building or may be wholly or partially supported by columns, poles or braces extended from the ground.

(4) ABOVE-CANOPY SIGN - A sign mounted to the top edge of the roof of a canopy, constructed of metal or similar rigid and solid materials, that projects vertically from the canopy to form the free-standing letters or graphics of the sign.

(5) FREE-STANDING SIGN - A sign, not attached to any building, and attached to the ground by poles, braces, or other means.

(6) MARQUEE - A sign used in conjunction with a theater which is attached to, and supported by, the building and generally projects from the building; and, which in addition to permanent copy, may allow for changeable letters.

(7) MOBILE SIGN - A mobile sign is a sign that is affixed to a frame having wheels or is capable of being carried, or otherwise portable; does not have a permanent foundation; cannot withstand the stress and wind loads of the Building Code; and is designed to stand free from a building or other structure. Signs designed to be affixed to the surface of real estate shall be deemed free standing signs and not mobile signs, but the mere removal of wheels or temporary securing of a sign to the surface of real estate shall not prevent its being a mobile sign within this definition.

(8) MONUMENT SIGN - A free standing sign where the length of the base of the sign is a minimum of 75 percent (75%) of the length of the longest part of the sign.

(9) PROJECTING SIGN - A sign which is attached directly to a canopy, marquee, or wall of a building and which extends horizontally outward from such canopy, marquee or wall more than twenty-four (24) inches.

(10) ROOF SIGN - A sign which projects above the cornice of a flat roof, or above the top edge of any roof, including the ridge line of a gabled or hipped roof. Such top edge shall not include any cupolas, pylons, chimneys or other minor projections above the roof line.

(11) WALL-MOUNTED SIGN - A sign attached parallel to and extending not more than twenty-four (24) inches from the wall of the building; and includes painted, individual letter and cabinet signs, signs on a mansard, or on a parapet not exceeding six (6) feet in height; and provided the parapet extends on at least three sides of a building and signs erected on or against the side of a roof but not projecting above the roof line. No copy shall be permitted to be displayed on the sides of the sign which are perpendicular to the wall face.

(12) PAINTED SIGN - Any sign which is applied with paint or similar substance directly to a wall or other surface. Any painted sign shall be subject to the regulations of the zone in which it is located.

(13) WINDOW SIGN - A sign which is painted on, or applied or attached to, the interior of a window or located within three (3) feet of the interior of a window, and which can be seen through the window from the exterior of the structure.

Merchandise which is included in a window display shall not be included as a part of a window sign.

(14) CONSTRUCTION SCREENING SIGN - A temporary sign of fabric or mesh material attached to fencing surrounding a construction site to serve as a wind break or privacy screen. Such signs may incorporate the information permitted for construction signs as defined in Section 17-3(a)(5). Construction screening signs may also include designs, artwork, logos, pictures, words and other graphic representations related to the project under construction. Such signs shall be located on the active construction site only during construction and shall be removed prior to a permit for any permanent signage being issued by the Division of Building Inspection pursuant to the provisions of Section 17-4(a).

17-3(d) SIGN TYPES BY DESIGN FEATURES - The following categories of signs are hereby defined primarily by certain design features of the sign itself:

(1) NON-ILLUMINATED SIGN - A sign which does not emit or reflect artificial light from any source, either directly or indirectly.

(2) ILLUMINATED SIGN - A sign which emits or reflects, either directly or indirectly, artificial light from any source:

(a) DIRECTLY ILLUMINATED SIGN - A sign which is lighted by means of an unshielded light source (including neon tubing) which is visible as a part of the sign and where light travels directly from the source to the viewer's eye.

(b) INDIRECTLY ILLUMINATED SIGN - A sign whose light source is so situated as to project light onto the exterior or front of the sign surface, or to project light onto the building facade where the sign is located.

(c) INTERNALLY ILLUMINATED SIGN - A sign whose light source is within the sign, with the sign having a transparent or translucent background or cover which silhouettes opaque or translucent letters or designs.

(3) ROTATING OR MOVING SIGN - A sign, any portion of which moves by mechanical means, motion of the wind or other means. Such motion does not refer to methods of changing copy used on an electronic message display system.

(4) FLASHING OR BLINKING SIGN - A sign, the illumination of which is not kept constant and which contains an intermittent or sequential flashing light source for the purpose of either attracting attention to the sign or as a method of changing copy.

(5) ELECTRONIC MESSAGE DISPLAY SYSTEM - A sign with copy or images which includes, but is not limited to reflective disc, direct illumination, rotating veils, light emitting diodes (L.E.D.s), or liquid crystal diodes (L.C.D.s), and is controlled by means of a central computer or video control system and which has no audible sound.

17-3(e) OTHER SIGN TYPES AND DEFINITIONS - The following phrases are hereby defined for the purposes of this Article:

(1) ABANDONED SIGN - A sign and/or supporting structure which no longer identifies a business conducted or product sold on the premises; any advertising sign which no longer directs attention to a bona fide business conducted, product sold, or activity or campaign being conducted or for which no legal owner can be found. A sign shall be deemed as abandoned when the conditions described above have been in evidence for a period exceeding one hundred eighty (180) days. For the purposes of this definition, an advertising sign shall not be deemed abandoned solely because the sign has contained no copy for a period exceeding one hundred eighty (180) days.

(2) AREA OF A SIGN - Shall be defined and computed as follows:

(a) FREE-STANDING OR PROJECTING SIGNS:

(1) Any double-faced sign shall have only one face, the largest, counted in calculating the area.

- (2) Any sign with three or more sign faces shall have the area calculated by summing the area of the sign faces and dividing by two.
- (3) Any sign that is considered 3-dimensional in shape shall have the area calculated by projecting the sign onto a vertical plane and summing the area of the sign face for all sides of the sign designed to attract attention or to communicate information that can be seen at any one time by a person from one vantage point.
- (4) If the sign is composed of one or two individual cabinets, the area around and enclosing the perimeter of each cabinet or module shall be summed and totaled to determine the area. The perimeter of the measurable area shall not include embellishments such as pole covers; framing; decorative roofing, etc.; provided there is no written copy on such embellishments and such embellishments are clearly incidental to the sign itself.
- (5) If the sign is composed of more than two sign cabinets, or modules, the area enclosing the entire perimeter of all cabinets and/or modules within a single contiguous geometric figure shall be the area of the sign. The measurable area shall not include embellishments such as pole covers; framing; decorative roofing; etc., provided there is no written copy on such embellishments and such embellishments are clearly incidental to the sign itself.

(b) WALL SIGNS - The area shall be within a single continuous perimeter composed of any straight line geometric figure which encloses the extreme limits of the copy, including vertical and horizontal spacing between individual letters, logos, etc.

(3) BANNER SIGN, PENNANT OR STREAMER - An identification sign, a temporary sign or a business sign made of durable fabric only, and not made of wood, metal or soft or hard plastic, having no enclosing framework. Such banner sign, pennant or streamer may be non-illuminated or indirectly illuminated only.

(4) CLEARANCE OF A SIGN - The least vertical distance between the lowest point of any sign, including the framework, and the established grade at the sign.

(5) HEIGHT OF A SIGN - The vertical distance measured from the highest point of the sign, including the frame and any embellishments and the established grade at the adjacent street.

(6) FACE OF A SIGN - The vertical area of the sign on which the copy is placed.

(7) COPY - Any word, letter, number, or emblem affixed to the sign surface, either permanently or in removable form.

(8) DOUBLE-FACED SIGN - A sign with two faces either set parallel or up to a forty-five degree (45°) angle. Any two sign faces set at an angle greater than forty-five degrees (45°) shall be considered two separate signs.

(9) ILLEGAL SIGN - A sign which does not meet the requirements of this Zoning Ordinance and which is not non-conforming.

(10) NON-CONFORMING SIGN - A sign which was legally erected, but which does not comply with the adopted sign regulations of this Zoning Ordinance for the zone in which it is located.

(11) SETBACK OF A SIGN - The horizontal distance between any street right-of-way and a free-standing sign and/or its supporting structure. The measurement shall be taken at the closest point proximity between the right-of-way and any part of the sign or structure.

(12) BUILDING FRONTAGE - The horizontal, linear dimension of that side of a building which abuts a street, parking area, or other unenclosed circulation area open to the general public. Where more than one use occupies a building, the building frontage shall be the front width of the portion of the building occupied by that use.

(13) STREET FRONTAGE - The linear distance between the lot lines measured along the abutting public or private street.

17-4 GENERAL PROVISIONS

17-4(a) PERMIT REQUIREMENTS - No sign, except as specifically exempted herein, shall be displayed, erected, relocated or altered unless and until a permit has been issued by the Division of Building Inspection. Application materials shall be as required by the Division of Building Inspection, and shall include, but shall not be limited to the following:

- (1) A completed application form.
- (2) A site plan and/or building elevation drawing, showing the location of the proposed sign(s) on the lot and/or building, including setbacks.
- (3) Detailed sign information, including type of construction, method of illumination, dimensions, copy, method of mounting and/or erecting and other similar information.
- (4) The written consent of the owner of the underlying real property or authorized agent.
- (5) A permit fee in an amount determined by the Urban County Council.

The Division of Building Inspection shall maintain written records of all permits issued or formally denied and any conditions attached to approval of such permit requests. Signs may be erected or constructed only in compliance with the approved permit.

17-4(b) ENFORCEMENT – Except as provided herein, the Division of Planning shall enforce the provisions of this Article and shall utilize its powers to ensure compliance with its provisions and the provisions of any approved permit. The Division shall maintain written records of any enforcement actions taken. The Division of Code Enforcement shall also have enforcement authority as to the provisions of Sections 17-4(g) and (j) below, and shall maintain written records of any enforcement actions taken.

17-4(c) SIGNS EXEMPT FROM PERMIT REQUIREMENTS - The following signs shall not require a permit. However, such signs are subject to applicable restrictions contained within this Article, and the Division of Planning shall take enforcement action against any such sign which does not conform to the specified requirements.

- (1) Political Signs;
- (2) Nameplates;
- (3) Government Signs;
- (4) Real Estate Signs;
- (5) Incidental Signs;
- (6) Window Signs; and
- (7) The changing of copy on a billboard, attraction board, marquee, informational sign, or electronic message display system.

17-4(d) REMOVAL OF REAL ESTATE SIGNS - All real estate and tract signs shall be removed within ten (10) days after completion of the sales, rental or lease activities in connection with the property or tract to which they pertain.

17-4(e) ILLUMINATED SIGNS NEAR RESIDENTIAL ZONES - Illuminated signs shall be located in a fashion which minimizes, to the greatest feasible extent, the direct rays of such illumination penetrating into any residential zone or property used for residential purposes.

17-4 (f) IMITATION OF OFFICIAL SIGNAGE - No light, sign or other advertising device shall be designed or erected in such a manner or location as to imitate or resemble any

official traffic sign, signal or device or use any words, phrases, symbols or characters implying the existence of danger, or the need to stop or maneuver the vehicle.

17-4(g) SIGNS ON TREES, UTILITY POLES OR OTHER STRUCTURES - No sign shall be attached to or painted on the surface of any tree, utility pole, street light standard, or dilapidated structure.

17-4(h) LIGHTING ON INDIRECTLY ILLUMINATED SIGNS - Gooseneck and thin line reflectors and lighting shall be permitted on indirectly illuminated signs, provided such do not extend six (6) feet beyond the sign structure to which they are attached and such illumination is directed upon the sign in such a fashion as to reduce the possibility of direct light rays shining onto any adjacent property or public way.

17-4(i) NEON SIGNS - Neon lighting and tubing and other exposed light sources not exceeding one hundred (100) watts per bulb may be used on signs where signs are permitted to be directly illuminated as defined in this Article.

17-4(j) SIGNS WITHIN SIGHT TRIANGLES - No sign (except for government signs), may be located within the required sight triangle of any intersection, nor within or projecting into the public or private street right-of-way, except as specifically permitted herein.

17-4(k) SIGNS FOR NON-CONFORMING USES - Signs accessory to legal non-conforming uses shall be permitted and shall be subject to the regulations of the zone in which the use is located.

17-4(l) LOCATION OF ALLOWABLE SIGNAGE BASED ON STREET FRONTAGE - Where signs are permitted on a lot on a per frontage basis under this Article, such signs shall be located and oriented to the distinct street frontage by which the sign is permitted. In addition, for free standing signs permitted on a lot on a per frontage basis, the signs on that lot may not be closer than seventy-five (75) feet from each other as measured in a straight line.

17-4(m) SIGNS AS A PERCENTAGE OF WALL AREA - Where wall signs are permitted as a percentage of the wall area to which they are attached, such wall area shall include all windows, doors, and wall area of the building in one plane of elevation. Where the building or wall face is broken or irregular in relation to a single vertical plane perpendicular to the ground (by such architectural features as dormers, pitched roofs, awnings, etc.), the requirements may be applied in one of two ways:

- (1) The total building face may be considered as one two-dimensional wall, and number of signs permitted and maximum area requirements applied on that basis.
- (2) Where each individual plane created by the architectural feature projects or is recessed by twelve (12) inches or more, each plane may be considered as a separate wall, and number of signs permitted and maximum area requirements applied on that basis. However, the total square footage of the permitted signs shall not exceed the square footage permitted under 17-4(m)(1) above, and no sign shall be oriented in a direction other than that of the building face under consideration.

17-4(n) INCIDENTAL SIGNS - No incidental sign shall be attached to a free standing advertising sign, business sign, identification sign or directional sign.

17-4(o) CANOPY SIGNS AS PART OF ALLOWABLE WALL SIGNAGE - Canopy signs shall be counted as a part of and limited to the percentage allowable for wall signs. The height of canopy signs shall not exceed twenty (20) feet. For any case where the vertical dimension of the canopy face exceeds five (5) feet, only five (5) feet of the vertical dimension shall be used for computing the area of such facing, and any sign or sign cabinet permitted shall have a maximum vertical dimension of three (3) feet.

17-4(p) SIGNAGE FOR MULTIPLE USES - Where more than one use occupies a building, the permitted sign area shall be based on the building frontage or wall area, as applicable, of that use.

17-4(g) PERMITTED SIGN AREA BASED ON FRONT- AGE - Street or building frontage used as a basis of determining permitted sign area for a building or use shall not be used as the basis for determining the permitted sign area for another building or use.

17-5 PROHIBITED SIGNS IN ALL ZONES - The following signs and/or sign features shall be prohibited in all zones.

- (a) Mobile Signs.
- (b) Roof Signs.
- (c) Flashing or Blinking Signs, except for permitted informational signs.
- (d) Rotating or Moving Signs.
- (e) Abandoned Signs.
- (f) Streamers, pennants and tag signs or similar signs or devices made of wood, plastic, metal, or similar material, other than cloth, except when attached to a permitted temporary sign.
- (g) Any sign which emits any noise, odor or visible matter for the purpose of attracting attention to the sign.
- (h) Any free-standing sign, any portion of which overhangs any part of a building.

17-6 PERMITTED SIGNS IN ALL ZONES - The following signs shall be permitted within all zones, subject to the restrictions specified:

- (a) Government signs with no restrictions on size, number or location.
- (b) Political signs, not exceeding four (4) square feet in area, limited to one sign per street frontage; and erected no earlier than thirty (30) days prior to the election they pertain to; and removed within five (5) days after such election.
- (c) Real estate signs, limited to one (1) sign per street frontage, and further regulated as follows:
 - (1) When associated with agricultural or residential (other than a Group Residential Project) use of the property, such sign area shall not exceed six (6) square feet in area and six (6) feet in height. Such sign shall be non-illuminated.
 - (2) When associated with business, commercial or industrial use of the property, a mixed-use development, or a Group Residential Project, such sign area shall not exceed thirty-two (32) square feet in area and ten (10) feet in height; except such a sign may be permitted up to, but shall not exceed, sixty-four (64) square feet in area when:
 - (a) the building to which such a sign pertains contains 100,000 or more square feet, or
 - (b) the site to which such a sign pertains contains two (2) or more acres.Such sign shall be non-illuminated or indirectly illuminated.
 - (3) When associated with vacant property where no structure exists other than for an agricultural use or in an agricultural zone, such sign area shall not exceed sixteen (16) square feet in area and six (6) feet in height. Such sign shall be non-illuminated.
- (d) Construction signs, not exceeding sixty-four (64) square feet, limited to one per street frontage in multi-family residential, office, business, and industrial zones; or where one sign is to be utilized, the permitted sign area may be totaled by summing the square footage permitted on each street frontage. In agricultural, single family and two-family zones, construction signs shall not exceed thirty-two (32) square feet and shall be limited to one per street frontage. All construction signs shall be non-illuminated or indirectly illuminated and shall be removed prior to issuance of an occupancy permit for the structure to which they pertain.

- (e) Tract signs, set back from any street as required for a principal structure within the zone; non-illuminated, and further regulated as follows:
 - (1) Where the subdivision contains twenty-five (25) lots or less, the sign area shall not exceed sixty-four (64) square feet.
 - (2) Where the subdivision contains more than twenty-five (25) lots, the sign area shall not exceed one hundred (100) square feet.
 - (3) Each subdivision shall be permitted one (1) tract sign per arterial or collector street frontage, provided the total number of signs shall not exceed four (4) signs.
- (f) Incidental Signs.
- (g) Temporary signs, not specifically otherwise regulated, in accordance with the following conditions:
 - (1) Such signs shall be limited to window or wall signs only; shall not exceed one hundred (100) square feet in surface area per use where non-rigid materials are used; and shall not exceed thirty-two (32) square feet per use where rigid materials such as wallboard or plywood are utilized; and shall comply with the applicable regulations for the zone in which they are located.
 - (2) Such signs shall not remain in place for a period of more than thirty (30) days; except that the Division of Building Inspection may, for good cause, extend the time period for an additional 30 days upon application therefore. In addition, no use shall be permitted to display a temporary sign for more than a total of 150 days during any calendar year.
- (h) Historic markers not exceeding six (6) square feet in area, limited to one sign per street frontage.
- (i) Landmark and district identification signs may be permitted with the approval of the Commissioner of Public Works and Development (or designee) and a four-member sign review committee established by the Mayor. In addition to the Commissioner of Public Works and Development, the committee shall consist of at least one (1) architect, licensed in the Commonwealth of Kentucky, and at least one (1) building inspector from the Division of Building Inspection. Any such signs shall meet all applicable Kentucky Building Code and Kentucky Fire Safety Code requirements.

A landmark or district identification sign shall be evaluated by the sign review committee, based on the following criteria:

- (1) The sign exhibits distinctive stylistic features and an unusual use of material in the design.
 - (2) The sign is an example of artistic design and skilled craftsmanship.
 - (3) The sign is a significant part of the architectural or cultural history of the community.
- (j) Temporary signs related to events that are sponsored by neighborhood associations or owners' associations that are located within the public or private street right-of-way of that neighborhood, and that do not otherwise interfere with sight in violation of Section 17-4(j). There shall not be more than ten (10) signs for any such event, and each such sign shall not exceed six (6) square feet in area and six (6) feet in height; shall not be displayed more than seven (7) calendar days prior to the event; and must be removed within two (2) calendar days after the event.

17-7 PERMITTED SIGNS BY ZONE - The following sign regulations shall be applicable within the zoning categories indicated. Any sign not specifically permitted shall be deemed as prohibited.

17-7(a) AGRICULTURAL ZONES (A-R, A-U, A-B and A-N) - Permitted signs within these zones may be either free standing or wall mounted unless otherwise specified; no

free standing sign may exceed ten (10) feet in height; signs shall be either non-illuminated or indirectly illuminated unless otherwise specified.

- (1) One nameplate per residence or other permitted use, not exceeding one (1) square foot in area.
- (2) One identification sign for a bed and breakfast facility permitted as a conditional use, not exceeding two (2) square feet in area.
- (3) One identification sign for a farm or estate, not exceeding ten (10) square feet.
- (4) One identification sign for any permitted use not otherwise specifically provided for, not exceeding thirty-two (32) square feet in area.
- (5) One identification sign for a permitted place of religious assembly or school for academic instruction, free standing or wall mounted; not exceeding thirty-two (32) square feet in area; not exceeding eight (8) feet in height if free standing; in addition, one bulletin board not exceeding twelve (12) square feet in area and eight (8) feet in height.
- (6) One non-illuminated business sign advertising agricultural products grown or raised on the premises, not exceeding thirty-two (32) square feet in area.
- (7) For farms utilizing more than one point of access, one non-illuminated or indirectly illuminated sign per entrance, indicating the name of the farm and directional information, as necessary to provide information as to the particular farm activity which must be served by only that point of access; not to exceed ten (10) square feet in area; maximum height of ten (10) feet.
- (8) Subdivision entrance identification signs of permanent construction, free standing or wall mounted; not exceeding thirty-two (32) square feet in area; no more than two per entrance; not more than two entrances to be identified. Such signs may be located in the right-of-way (in the median or at each side of the street) subject to written authorization of the Commissioner of Public Works, who shall determine that the signs would not be located in the sight triangle and would not cause a hazard to traffic. Proof of permanent maintenance and an encroachment permit shall be provided by the applicant prior to the issuance of a permit for a subdivision entrance identification sign located in the right-of-way.

17-7(b) LOW DENSITY RESIDENTIAL ZONES (R-1 [A THROUGH E], R-1T, R-2) -

Permitted signs within these zones shall be wall signs unless otherwise specified; signs shall be either non-illuminated or indirectly illuminated. Minimum setback for any free standing sign permitted under this section shall be one-half ($\frac{1}{2}$) the minimum front yard requirement for the zone in which the sign is to be located; and no less than ten (10) feet in any case.

- (1) One nameplate per residence or other permitted use, not exceeding one (1) square foot in area.
- (2) One identification sign, for a farm or estate exceeding five (5) acres in size, free standing or wall mounted; not exceeding ten (10) square feet in area; not exceeding ten (10) feet in height if free standing.
- (3) One identification sign for a permitted kindergarten, nursery school, day nursery, or child care center, wall mounted not more than seven (7) feet above ground level; not exceeding two (2) square feet in area.
- (4) One identification sign for a permitted place of religious assembly or school for academic instruction, free standing or wall mounted; not exceeding thirty-two (32) square feet in area; not exceeding eight (8) feet in height if free standing; in addition, one bulletin board, free standing or wall mounted, not exceeding twelve (12) square feet in area and eight (8) feet in height. If the property has five or more acres and has frontage on two or more streets, then a second identification sign and bulletin board, meeting the same requirements as the first sign shall be permitted, limited to one per street frontage; provided these signs are located a

minimum of two hundred fifty (250) feet from each other. In addition, in the A-U zone, if the property has five (5) or more acres and has frontage on two or more streets, then a second identification sign and bulletin board, meeting the same requirements as the first sign shall be permitted, limited to one (1) per street frontage; provided these signs are located a minimum of two hundred fifty (250) feet from each other.

- (6) One identification sign for any permitted use not otherwise specifically provided for, free standing or wall mounted; not exceeding thirty-two (32) square feet in area; not exceeding eight (8) feet in height if free standing.
- (7) Subdivision entrance identification signs of permanent construction, free standing or wall mounted; not exceeding thirty-two (32) square feet in area; not exceeding six (6) feet in height if free standing; no more than two per entrance; not more than two entrances to be identified, or not more than four entrances to be identified when all such signs are oriented to an intersection with an arterial, collector, boulevard or parkway. Such signs may be located in the right-of-way (in the median or at each side of the street) subject to written authorization of the Commissioner of Public Works, who shall determine that the signs would not be located in the sight triangle and would not cause a hazard to traffic. Proof of permanent maintenance and an encroachment permit shall be provided by the applicant prior to the issuance of a permit for a subdivision entrance identification sign located in the right-of-way.
- (8) For a Group Residential Project within the R-1T zone only, one non-illuminated directional sign per entrance, not exceeding three (3) square feet in area; and not exceeding three (3) feet in height if free standing; not to exceed four (4) signs per Group Residential Project.
- (9) One identification sign for a bed and breakfast facility permitted as a conditional use, free standing or wall mounted; not exceeding two (2) square feet in area; not exceeding six (6) feet in height if free standing.

17-7(c) HIGH DENSITY RESIDENTIAL ZONES (R-3 & R-4) - Permitted signs within these zones shall be free standing or wall mounted as specifically noted; signs shall be either non-illuminated or indirectly illuminated.

- (1) Signs as permitted and regulated under Section 17-7(b) above.
- (2) One identification sign for a multi-family residential building containing four (4) or more dwelling units and not located within a Group Residential Project, free standing or wall mounted; not exceeding thirty-two (32) square feet in area; not exceeding eight (8) feet in height if free standing; minimum setback of at least twenty (20) feet.
- (3) Identification sign(s) for a Group Residential Project, one sign per street frontage, with a maximum of two (2) signs; free standing or wall mounted; not exceeding thirty-two (32) square feet in area per sign; not exceeding eight (8) feet in height if free standing; minimum setback of at least twenty (20) feet.
- (4) Pole-banner signs shall be permitted only if displayed in a parking area approved as a conditional use to be accessory to a mixed-use project, and subject to the following restrictions:
 - (a) Banner signs shall be a maximum size of two (2) feet by four (4) feet, and there shall be no more than two (2) per pole.
 - (b) Banner signs may not advertise a specific business or products, goods or services.
 - (c) Pole-mounted banners shall be permitted on light fixtures in parking areas located outside the public right-of-way.
 - (d) Banner poles shall be spaced to be no closer than forty-five (45) feet from each other.

- (e) The total number of pole-mounted banner signs shall be limited to one (1) for every 3,000 square feet of parking area.
- (f) All pole-mounted banner signs shall provide a minimum of eight (8) feet of vertical clearance, and may not encroach into the right-of-way.

17-7(d) HIGH-RISE APARTMENT ZONE (R-5) - Permitted signs within this zone shall be free standing or wall mounted, as specifically noted; signs may be internally illuminated only when across a public street from any office, business or industrial zone; otherwise, signs shall be either non-illuminated or indirectly illuminated.

- (1) Signs as permitted and regulated under Section 17-7(c) above, except for subdivision entrance identification signs.
- (2) One wall-mounted business sign per building, identifying any or all incidental retail uses allowed as a conditional use, not exceeding sixteen (16) square feet in area. Where utilized, the otherwise permitted wall signs in the R-5 zone shall not be allowed.
- (3) One wall-mounted business sign per extended-stay hotel conditional use; not exceeding thirty-two (32) square feet in area.
- (4) In addition, when located within $\frac{3}{4}$ mile of an interchange for a designated interstate highway, one wall-mounted business sign visible from the interstate highway per extended-stay conditional use, but not below a minimum height of seventy-five (75) feet from the base of the wall; not exceeding one hundred fifty (150) square feet in area.
- (5) In addition, one wall-mounted business sign per principal permitted office use, not exceeding two (2) square feet in area. Where utilized, the otherwise permitted nameplate shall not be allowed.

17-7(e) PROFESSIONAL OFFICE ZONE (P-1) AND MIXED USE 1: NEIGHBORHOOD NODE ZONE (MU-1) - Permitted signs may be either free standing or wall mounted, as specifically noted; signs shall be non-illuminated, indirectly illuminated, or internally illuminated unless otherwise specified. No free-standing sign shall exceed ten (10) feet in height, with the exception of hospitals, as regulated below.

- (1) One free-standing identification or business sign per building; not to exceed forty (40) square feet in area, with a minimum setback of ten (10) feet.
- (2) One wall-mounted identification or business sign for buildings with one street frontage, not to exceed five percent (5%) of the wall area to which it is attached. When a free-standing sign is not utilized on a lot with only one street frontage, a second wall-mounted sign on a different building face shall be permitted as regulated above in place of the permitted free-standing sign.
- (3) Two wall-mounted identification or business signs for buildings with two street frontages, located on separate wall faces, not to exceed five percent (5%) of the wall area to which the signs are attached.
- (4) Three wall-mounted identification or business signs for buildings three (3) stories or taller with two street frontages, located on separate wall faces, not to exceed five percent (5%) of the wall area to which the signs are attached. Signs not located on a street frontage shall not be placed on a building face directly adjacent to any residential zone.
- (5) One nameplate per tenant or lessee, not exceeding two (2) square feet in area; non-illuminated or indirectly illuminated only.
- (6) Informational signs, not exceeding twenty (20) square feet. Such signs shall be included in the computation for maximum square footage specified under 17-7(e)(1) above, and shall be free standing only when included as a part of a permitted free-standing identification sign.
- (7) Directional signs not exceeding three (3) feet in height if free standing; not to exceed two (2) signs per entrance.

- (8) One attraction board, wall mounted or attached to the permitted free-standing identification sign, the area of the attraction board to be included in the maximum permitted sign area.
- (9) Canopy or awning signs, limited to fifteen percent (15%) of the area of the surface to which they are attached. Such signs shall be included in the computation of the maximum permitted sign area specified under 17-7(e)(1) above.
- (10) In addition, and within a designated Professional Office Project only:
 - (a) One project identification sign, free standing or wall mounted; not exceeding one hundred (100) square feet in area.
 - (b) One identification sign, wall mounted; not exceeding fifteen (15) square feet in area for a restaurant, cocktail lounge or night club.
 - (c) Project entrance identification signs of permanent construction, free standing or wall mounted; not exceeding thirty-two (32) square feet in area; not exceeding eight (8) feet in height; and no more than two per entrance. Such signs may be located in the right-of-way (in the median or at each side of the street), subject to written authorization of the Commissioner of Public Works, who shall determine that the signs would not be located in the sight triangle and would not cause a hazard to traffic. Proof of permanent maintenance and an encroachment permit shall be provided by the applicant prior to the issuance of a permit for a subdivision entrance identification sign located in the right-of-way.
 - (d) A third wall-mounted identification or business sign shall be allowed for buildings with two street frontages. Such sign shall be located on a separate wall face of the building not already displaying a wall-mounted sign, not to exceed five percent (5%) of the wall area to which it is attached.
- (11) Construction screening signs, limited to twenty percent (20%) of the total square footage of the face of the construction screen. Signage shall not be displayed along an agriculturally or residentially zoned property boundary.
- (12) In addition, and within a hospital campus or Regional Medical Campus [as generally defined in 23A-10(b)(9)], only:
 - (a) Project identification signs, maximum of three per campus, free standing or wall mounted. A project identification sign located along a street classified as a collector or an arterial shall not exceed one hundred fifty (150) square feet in area and twenty (20) feet in height. A project identification sign located at the intersection of a street classified as a collector or an arterial and a local street shall not exceed seventy-five (75) square feet and fifteen (15) feet in height. No project identification signs shall be located along a street classified as a local street or at the intersection of two local streets.
 - (b) Project entrance identification signs of permanent construction, free standing or wall mounted; not exceeding one hundred (100) square feet in area; not exceeding ten (10) feet in height; no more than two per entrance along a street classified as a collector or arterial; not more than two entrances to be identified per campus. Such signs shall only be located at entrances shown on an approved development plan.
 - (c) Three wall-mounted identification or business signs for buildings with two street frontages, located on separate wall faces, not to exceed five percent (5%) of the wall area to which the signs are attached. Signs not located on a street frontage shall not be placed on a building face directly adjacent to any residential zone.

17-7(f) NEIGHBORHOOD BUSINESS ZONE (B-1) - Permitted signs may be free standing or wall mounted, as specified; signs shall be non-illuminated, indirectly illuminated, or internally illuminated unless specified otherwise. No free-standing sign shall exceed twenty (20) feet in height.

- (1) Business signs shall be permitted as follows:
 - (a) The total surface area of business signs shall not exceed one and one-half (1½) square feet per linear foot of street or building frontage, whichever is greater; or thirty-two (32) square feet, whichever is greater.
 - (b) One free-standing business sign shall be permitted per street frontage, with a maximum of two (2) free-standing signs; not exceeding fifty (50) square feet per sign; minimum setback one-half the setback required for a principal building, but not less than ten (10) feet in any case.
 - (c) One projecting business sign not exceeding fifty (50) square feet in area, not exceeding twelve (12) feet in height, and only directly or indirectly illuminated, shall be permitted in lieu of all free-standing business signage, as permitted herein, under the following circumstances:
 - (1) the parcel on which the sign is placed is located within the defined Infill and Redevelopment Area; and
 - (2) the existing principal structure on the parcel is located ten (10) feet or less from the front property line.
 - (d) The surface area of a wall-mounted business sign shall not exceed fifteen percent (15%) of the wall area to which it is attached or thirty-two (32) square feet, whichever is greater, each wall to be considered separately. Only one business sign shall be permitted per wall. In the case of a building containing two or more separate business uses, these requirements shall be applied separately to the wall area of the building space leased, rented or owned by the individual business tenant.
 - (e) Window signs shall be permitted, limited to no more than twenty-five percent (25%) of the total window area, and direct illumination shall be permitted.
 - (f) Canopy or awning signs (including above-canopy signs) shall be permitted and included in the computation of the maximum permitted sign area and limited to the percentage allowable for wall signs. Under-canopy or under-awning signs shall be permitted and limited to identification signs.
- (2) In conjunction with an indoor theater, one marquee, not to exceed twenty-four (24) square feet per theater; such marquee shall project no more than eight (8) feet from the building face to which it is attached and shall have a minimum clearance of eight (8) feet. In addition, one attraction board attached to one free-standing business sign, not to exceed twenty-four (24) square feet per theater. The area of the marquee and attraction board shall be included in the computation of the maximum permitted sign area.

(Note: Where an attraction board attached to a free-standing business sign is not utilized, a second marquee, mounted on a different building face, shall be permitted as regulated above.)
- (3) One attraction board, wall mounted or attached to a permitted free-standing business sign; the area of the attraction board to be included in the maximum permitted sign area.
- (4) Directional signs not exceeding three (3) square feet in area, not exceeding three (3) feet in height; if free standing, not to exceed two (2) signs per entrance.
- (5) One nameplate per tenant or lessee, not exceeding two (2) square feet in area; non-illuminated or indirectly illuminated.
- (6) Informational signs, not exceeding twenty (20) square feet. Such signs shall be included in the computation for maximum square footage specified under 17-7(f)(1) above, and shall be free standing only when included as a part of a permitted free-standing identification sign.

- (7) One menu board per restaurant use or one menu board per drive-through lane. All copy (including any logos, restaurant name, etc., shall have a maximum letter height and width of six (6) inches, containing no direct illumination; not exceeding forty-five (45) square feet in area; maximum height of eight (8) feet if free standing; and not located so as to have the copy visible to vehicular traffic on any adjacent street.
- (8) One menu box per restaurant use, not exceeding four (4) square feet.
- (9) Construction screening signs, limited to twenty percent (20%) of the total square footage of the face of the construction screen. Signage shall not be displayed along an agriculturally or residentially zoned property boundary.

17-7(g) HIGHWAY SERVICE BUSINESS, WARE- HOUSE/WHOLESALE, AND INDUSTRIAL ZONES (B-3, B-4, I-1, I-2) - Permitted signs may be free standing or wall mounted, as specified; signs may be non-illuminated, indirectly illuminated, internally illuminated or directly illuminated unless specified otherwise; no free-standing business sign shall exceed twenty-five (25) feet in height; no free-standing advertising sign shall exceed forty (40) feet in height.

(1) Business signs shall be permitted as follows:

- (a) The total surface area of business signs shall not exceed two (2) square feet per linear foot of street or building frontage, whichever is greater; or thirty-two (32) square feet, whichever is greater.
 - (b) One free-standing business sign per lot shall be permitted per street frontage, with a maximum of two (2) free-standing signs; not exceeding seventy-five (75) square feet per sign; minimum setback shall be one-half ($\frac{1}{2}$) the setback required for a principal building, but not less than ten (10) feet in any case. Free-standing business signs shall be located at least fifty (50) feet away from any identification signs allowed under Section 17-7(g)(10) herein.
 - (c) The surface area of wall-mounted business sign(s) shall not exceed fifteen percent (15%) of the wall area to which it is attached or thirty-two (32) square feet, whichever is greater, each wall to be considered separately. Only one business sign shall be permitted per wall. In the case of a building containing two or more separate business uses, these requirements shall be applied separately to the wall area of the building space leased, rented or owned by the individual business tenant.
 - (d) Window signs shall be permitted, limited to no more than twenty-five percent (25%) of the total window area.
- (2) Nameplates, directional signs, informational signs and signs on or under a canopy or awning shall be permitted as regulated in the B-1 zone.
- (3) In conjunction with an indoor theater: one marquee, not to exceed twenty-four (24) square feet per theater; such marquee shall project no more than eight (8) feet from the building face to which it is attached and shall have a minimum clearance of eight (8) feet. In addition, one attraction board attached to one free-standing business sign, not to exceed twenty-four (24) square feet per theater. The area of the marquee and attraction board shall be included in the computation of the maximum permitted sign area.
- (Note: Where an attraction board attached to a free- standing business sign is not utilized, a second marquee, mounted on a different building face, shall be permitted as regulated above.)
- (4) One attraction board, wall mounted or attached to a permitted free-standing business sign, the area of the attraction board to be included in the maximum permitted sign area.
- (5) Menu boards as permitted and regulated in the B-1 zone.

- (6) In addition, advertising sign structures shall be permitted as follows:
- (a) The lot must abut a federal or state highway.
 - (b) No advertising sign structure shall exceed 400 square feet in area.
 - (c) No advertising sign shall be permitted within 150 feet of any residential zone.
 - (d) No advertising sign structures shall be located within 500 feet of another advertising sign structure, unless one of the two signs located within 500 feet of another sign meets the requirements of, and has been allowed under, sub-paragraph (f) below.
 - (e) Advertising signs shall be required to be set back from any street right-of-way twenty (20) feet, or at the same setback as any principal building on the lot, whichever is less.
 - (f) An advertising sign structure located not less than 200 feet from another advertising sign structure shall be permitted as follows:
 - (1) The requirements of sub-paragraphs (a), (c) and (e) above shall be met.
 - (2) The advertising sign shall be limited to the identification of, and directional information for, a motel or hotel that is not located on a federal or state highway.
 - (3) Any business signs located on the motel or hotel lot shall not be visible from the federal or state highway abutting the lot on which the advertising sign is located.
 - (4) The advertising sign structure shall not exceed fifty (50) square feet in area, and its height shall not exceed forty (40) feet.
 - (5) The advertising sign shall be attached to an existing free-standing business sign structure, and no other advertising signs shall be permitted on the same lot.
 - (6) No advertising signs shall be permitted on the motel or hotel lot.
 - (7) The motel or hotel lot shall be located not more than 1,000 feet from the federal or state highway abutting the lot on which the advertising sign is located.
- (7) As part of a permitted free-standing or wall-mounted advertising or business sign for an indoor or outdoor stadium or arena located in a B-3 zone having a permanent seating capacity in excess of 5,000 persons for athletic and cultural events, an electronic message display system shall be permitted; not exceeding 50% of the total sign area of the permitted sign, to be used exclusively to notify the public of events to be held in the stadium or arena. No moving or scrolling messages shall be permitted. Messages displayed may be changed not more frequently than every 15 seconds.
- (8) Pole-banner signs shall be permitted only if displayed in a parking area accessory to a mixed-use project, and subject to the following restrictions:
- (a) Banner signs shall be a maximum size of two (2) feet by four (4) feet, and there shall be no more than two (2) per pole.
 - (b) Banner signs may not advertise a specific business or products, goods or services.
 - (c) Pole-mounted banners shall be permitted on light fixtures in parking areas located outside the public right-of-way.
 - (d) Banner poles shall be spaced to be no closer than forty-five (45) feet from each other.
 - (e) The total number of pole-mounted banner signs shall be limited to one (1) for every 3,000 square feet of parking area.

- (f) All pole-mounted banner signs shall provide a minimum of eight (8) feet of vertical clearance, and may not encroach into the right-of-way.
- (9) Construction screening signs shall be permitted as regulated in the B-1 zone.
- (10) Identification signs, only for projects governed by a unified development plan and exceeding four (4) acres in size; one (1) identification sign shall be permitted per public street frontage, with a maximum of three (3) signs; not exceeding seventy-five (75) square feet per sign; with a maximum height of ten (10) feet. The total square footage of each identification sign shall be counted towards the maximum amount of business signage available for the lot allowed under Section 17-7(g)(1)(a) above. Identification signs shall be located at least fifty (50) feet away from any freestanding business signs.

17-7(h) DOWNTOWN BUSINESS ZONES (B-2, B-2A) - Permitted signs may be free standing or wall mounted, as specified; such signs may be non-illuminated, indirectly illuminated, internally illuminated or directly illuminated, unless specified otherwise.

(1) Business signs shall be permitted as follows:

- (a) Signs with general product advertising or lists of specific goods or services shall be prohibited.
 - (b) One free-standing sign shall be permitted for each street frontage, not to exceed two free-standing signs. The free-standing signs shall have a maximum area of forty (40) square feet, a maximum height of twenty (20) feet, and a maximum projection into the right-of-way of twelve (12) inches.
 - (c) One wall-mounted sign per building face shall be permitted, placed at a height of fifty (50) feet or higher. Such sign shall have a maximum area of three percent (3%) of the wall area to which it is attached, with a maximum projection into the right-of-way of twelve (12) inches.
 - (d) In addition to the wall sign permitted under (c) above, one additional wall-mounted sign shall be permitted per building face. Such sign shall have a maximum lettering height or vertical cabinet dimension of two and one-half (2½) feet, and shall be located at a height of less than fifty (50) feet on the building, with a maximum projection into the right-of-way of twelve (12) inches.
 - (e) In addition to the wall mounted signs permitted under (c) and (d) above, each establishment within the building, having a separate and direct entrance to the outside, shall be permitted one wall sign per street building face. Such sign shall be located no lower than ten (10) feet nor higher than thirty (30) feet on the building, and mounted on the building where the establishment is located. Such sign shall have a maximum area of one and one-half (1½) square feet per linear foot of frontage, not to exceed eighty (80) square feet, with a maximum projection into the right-of-way of twelve (12) inches.
 - (f) One projecting business sign, not exceeding fifty (50) square feet in area, shall be permitted for each establishment within the building having a separate and direct entrance to the outside. Such sign shall have a minimum vertical clearance of ten (10) feet and a height limit of thirty (30) feet as attached to the building. Such sign shall be mounted on the building so that it does not conflict with wall-mounted signs permitted under (e) above or with any windows, doors or other architectural features of the building; and with a maximum projection from the face of the building and into the adjacent right-of-way of eight (8) feet. In no case shall a projecting sign be closer than two (2) feet to the back of curb of any adjacent roadway.
 - (g) Window signs shall be permitted, limited to no more than twenty-five percent (25%) of the total window area.
- 2) Wall-mounted identification signs, not exceeding five (5) square feet, with a maximum letter height of six (6) inches; located no higher than ten (10) feet on the face of the building; one sign per establishment having a separate and direct

entrance to the outside; maximum projection into the right-of-way of twelve (12) inches.

- (3) Nameplates, directional signs, menu boards, menu boxes and informational signs shall be permitted as regulated in the B-1 zone.
- (4) Canopy or awning signs shall be permitted in lieu of allowable wall signs, not exceeding twenty percent (20%) of the face of the canopy or awning. Under-canopy or under-awning signs shall be permitted and limited to identification signs. Above-canopy signs shall be permitted and limited to the percentage allowable for wall signs.
- (5) Banner signs, pennants and streamers, with no general product advertising, or list of specific goods or services, shall be permitted; limited to one such banner, pennant or streamer per ten (10) feet of linear frontage, a total maximum area of fifteen percent (15%) of the wall area to which it is attached, a minimum of eight (8) feet of vertical clearance and a maximum projection into the right-of-way of three (3) feet.
- (6) A-frame or sandwich board type signs shall be permitted as follows:
 - (a) Maximum size of eight (8) square feet per panel, maximum height 48", maximum width 24";
 - (b) One sign per street front, maximum two signs;
 - (c) Placement of sign shall allow for four (4) clear feet of sidewalk width;
 - (d) Sign shall be in place only when business is open;
 - (e) Placement of sign not to restrict egress from parked cars, and not over curb line;
 - (f) Shall be maintained in good condition;
 - (g) Shall not be attached to any public utility pole, street light standard or tree;
 - (h) Non-illuminated;
 - (i) There shall be an annual renewal permit fee, as established under the Code of Ordinances.
- (7) In addition to the otherwise permitted signs, wall-mounted electronic message display center boards shall be permitted for civic centers which contain exhibition halls and an arena for athletic and cultural events; for hotels and motels containing conference centers and restaurants; for television and radio system signal distribution centers and studios; and for banks, securities and commodities brokers, credit institutions, savings and loans, and investment companies. The total surface area shall not exceed eighty (80) square feet per sign. One electronic message display center shall be permitted per street front, with a maximum of two signs.
- (8) Construction screening signs shall be permitted as regulated in the B-1 zone.

17-7(i) LEXINGTON CENTER BUSINESS ZONE (B-2B) - Permitted signs may be free standing or wall mounted, as specified; such signs may be non-illuminated, indirectly illuminated, internally illuminated or directly illuminated; painted wall signs shall be prohibited. No free-standing sign permitted under this section shall exceed twenty (20) feet in height, nor project into the right-of-way more than twelve (12) inches.

- (1) Business signs, wall-mounted identification signs, canopy or awning signs, under-canopy or under-awning signs, above-canopy signs and banner signs shall be permitted as regulated in the B-2 and B-2A zones.
- (2) In addition to the other signs permitted in this zone, four (4) wall-mounted electronic message display system signs shall be permitted for civic centers which contain exhibition halls and an arena for athletic and cultural events. Two (2) such signs, not exceeding 200 square feet, shall be permitted and shall be used primarily only to notify the public of special events in the civic center or to provide public service information. Two (2) additional signs may also be erected, not exceeding fifty (50) square feet each, and shall be used exclusively for directional and/or informational purposes. Electronic message display system signs may be mounted on the wall of the civic center or any structure having a

common wall with the civic center.

- (3) Nameplates, directional signs, menu boards and informational signs shall be permitted as regulated in the B-1 zone.
- (4) A-frame or sandwich board type signs shall be permitted and regulated as in the B-2 and B-2A zones.
- (5) Construction screening signs shall be permitted as regulated in the B-1 zone.

17-7(j) INTERCHANGE SERVICE BUSINESS ZONE (B-5P) - Permitted signs shall be either free standing or wall mounted; signs may be non-illuminated, indirectly illuminated, internally illuminated, or directly illuminated.

- (1) Wall-mounted business signs and window signs shall be regulated as under Section 17-7(f)(1). Free-standing signs shall be regulated as follows:
 - (a) One free-standing business sign per lot shall be permitted, with a maximum area of 356 square feet, with a maximum height of ninety (90) feet, but not below a minimum height of seventy-five (75) feet; a minimum setback of ten (10) feet from any right-of-way shall be required.
 - (b) In addition, one free-standing business sign per street frontage shall be permitted to a maximum of two (2) signs; sign area shall not exceed fifty (50) square feet; sign height shall not exceed twenty (20) feet; a minimum setback of ten (10) feet from any street shall be required.
- (2) One attraction board, wall mounted or attached to the free-standing business sign permitted under 17-7(j)(1)(b) above; the area of the attraction board to be included in the maximum permitted sign area.
- (3) Nameplates, menu boards, and directional signs shall be permitted and regulated as in the B-1 zone.
- (4) Construction screening signs shall be permitted as regulated in the B-1 zone.

17-7(k) PLANNED SHOPPING CENTER ZONE (B-6P) - Signs within the B-6P zone shall be permitted and regulated as for B-1 [Section 17-7(f)], except as follows:

- (1) In place of the free-standing signs permitted under Section 17-7(f)(1)(b), the only permitted free-standing signs shall be shopping center identification signs. One sign shall be permitted per street frontage, with a maximum of two (2) signs. The maximum square footage of each sign shall be 150 square feet, with a maximum height of twenty-five (25) feet for a regional shopping center; and seventy-five (75) square feet, with a maximum height of twenty (20) feet in a community or neighborhood shopping center.

A shopping center identification sign that otherwise conforms to the requirements listed above may include either an attraction board or up to six (6) tenant panels. The shopping center identification sign portion of the free-standing sign shall at no time be less than sixty percent (60%) of the total square footage. The area of any tenant panel(s) or attraction board shall be included in the computation of the area of the total free-standing sign, not to exceed forty percent (40%) of the area of the free-standing sign. Tenant panels shall be legible to motorists traveling at a normal rate of speed when located a minimum of two hundred (200) feet from the sign location. An attraction board shall have no permanent copy identifying any specific business or product sold within the center. The copy on such an attraction board shall be limited to sales or other events on the premises and civic meetings, rallies or other noncommercial events, on or off the premises.

- (2) The wall-mounted signs shall show only the name and/or logo of the business or profession, and shall contain no product trade name identifications. A listing of any products sold or offered on the premises may be an integral part of, and incorporated into, each permitted wall sign, provided the listing occupies no more than fifty percent (50%) of the area of the sign.

- (3) Window signs shall be permitted, limited to no more than twenty-five percent (25%) of the total window area.
- (4) Non-illuminated or indirectly illuminated projecting signs may be permitted only as a conditional use as described under Section 17-12, where the purpose of such projecting signs is to create a unified and distinct shopping area design and where such signs will be utilized in place of wall signs.

17-7(l) MOBILE HOME PARK ZONE (M-1P) - Permitted signs shall be either non-illuminated or indirectly illuminated.

- (1) One free-standing mobile home park identification sign shall be permitted; sign not to exceed thirty-two (32) square feet in area, not exceeding eight (8) feet in height, minimum setback of twenty (20) feet from any street.
- (2) One nameplate per mobile home; not exceeding one square foot in area.

17-7(m) PLANNED UNIT DEVELOPMENT ZONES (PUD) - Signs shall require a sign permit from the Division of Building Inspection. The height, size, location, design features, etc., of any sign accessory to a use first permitted in a residential zone shall be determined by the sign requirements for the zone in which the use is first permitted. All signs accessory to business or office uses shall be as permitted and regulated for a neighborhood shopping center in the Planned Shopping Center (B-6P) zone.

17-7(n) OFFICE, INDUSTRY AND RESEARCH PARK ZONE (P-2) - Signs within the P-2 zone shall be permitted and regulated as for P-1 [Section 17-7(e)], except as follows:

- (1) Wall-mounted identification signs shall be limited to one per wall, with a maximum of four (4); wall-mounted signs not to exceed five percent (5%) of the wall area to which it is attached.
- (2) Signs within the designated retail area shall be permitted and regulated as in the B-6P [Section 17-7(k)] zone.
- (3) Project entrance identification signs shall be permitted and regulated under Section 17-7(e)(10)(c) above.

17-7(o) MIXED USE 2: "NEIGHBORHOOD CORRIDOR ZONE" (MU-2) - Signage shall be as permitted and restricted as follows:

- (1) Signs shall be non-illuminated, indirectly illuminated or internally illuminated, unless otherwise specified.
- (2) No free-standing sign shall exceed ten (10) feet in height.
- (3) Identification or business signs shall be permitted as follows:
 - (a) One free-standing identification sign shall be permitted per street frontage, per development, with a maximum of two (2) free-standing signs; not exceeding seventy-five (75) square feet per sign.
 - (b) The surface area of wall-mounted business signs shall not exceed fifteen percent (15%) of the wall area to which they are attached, or thirty-two (32) square feet, whichever is greater; each wall to be considered separately. Only one business sign shall be permitted per wall. In the case of a building containing two or more separate business uses, these requirements shall be applied separately to the wall area of the building space leased, rented or owned by the individual business tenant.
 - (c) Window signs shall be permitted, limited to no more than twenty-five percent (25%) of the total window area; and direct illumination shall be permitted.
 - (d) Canopy or awning signs shall be permitted and limited to the percentage allowable for wall signs. Under-canopy or under-awning signs shall be permitted and limited to identification signs.
- (4) Projecting business signs shall be permitted in addition to wall-mounted business signs, where the purpose of such projecting signs is to create a unified and distinct mixed use area. No more than one (1) sign for each establishment within

the building, having a separate and direct entrance to the outside, per street building face. Such sign shall extend no lower than eight (8) feet over the public right-of-way and must be mounted on the building where the establishment is located. Such sign shall have a maximum area of twelve (12) square feet, with a maximum projection from the wall of the building of no more than four (4) feet.

- (5) An attraction board may be attached to a free-standing sign, provided it does not exceed the area of the identification sign and provided that no permanent copy identifying any specific business or product sold within the center is included on the attraction board. The area of the attraction board shall be included in the computation of the area of the free-standing sign. The copy on such an attraction board shall be limited to sales or other events on the premises and civic meetings, rallies or other non-commercial events on or off the premises.
- (6) Directional signs not exceeding three (3) square feet in area, not exceeding three (3) feet in height; if free standing, not to exceed two (2) signs per entrance.
- (7) One nameplate per tenant or lessee, not exceeding two (2) square feet in area; non-illuminated or indirectly illuminated.
- (8) One menu board per restaurant use. All copy (including any logos, restaurant name, etc.) shall have a maximum letter height and width of six (6) inches, containing no direct illumination; not exceeding thirty (30) square feet in area; maximum height of eight (8) feet if free standing; and not located so as to have the copy visible to vehicular traffic on any adjacent street.
- (9) Wall-mounted banner signs, pennants and streamers shall be permitted, with no general product advertising or list of specific goods or services; limited to one (1) such banner, pennant or streamer per ten (10) feet of linear frontage; a total maximum area of ten percent (10%) of the wall area to which it is attached; a minimum of eight (8) feet of vertical clearance; and a maximum projection into the right-of-way of three (3) feet.
- (10) Construction screening signs shall be permitted as regulated in the B-1 zone.

17-7(p) MIXED USE 3: "MIXED-USE COMMUNITY ZONE" (MU-3) - Signage shall be permitted and restricted as in the MU-2 zone, except as follows:

- (1) Wall-mounted banner signs, pennants and streamers shall be permitted for a total maximum area of fifteen percent (15%) of the wall area to which they are attached, with all other restrictions from the MU-2 zone.
- (2) Pole-mounted banner signs shall be permitted, subject to the following:
 - (a) Banner signs shall be a maximum size of two (2) feet by four (4) feet, and there shall be no more than two (2) per pole.
 - (b) Banner signs may not advertise specific businesses or products, goods or services.
 - (c) Pole-mounted banners shall be permitted on light fixtures in parking lots and pedestrian plazas located outside the public right-of-way.
 - (d) Banner poles shall be spaced to be no closer than forty-five (45) feet from each other.
 - (e) The total number of pole-mounted banner signs shall be limited to one (1) for every 3,000 square feet of parking lot or pedestrian plaza.
 - (f) All pole-mounted banner signs shall provide a minimum of eight (8) feet of vertical clearance, and may not encroach into the right-of-way.
 - (g) Pole banners in parking lots located in another zone that are incorporated in an approved final development plan for an MU-3 project are permitted, subject to the same restrictions and requirements applicable to the pole-banner signs for the MU-3 project.
- (3) A-frame or sandwich board type shall be permitted as follows:
 - (a) Maximum size of eight (8) square feet per panel, maximum height 48", maximum width 24";
 - (b) One sign per street frontage, maximum two signs;

- (c) Placement of sign shall allow for four (4) clear feet of sidewalk width;
 - (d) Sign shall be in place only when business is open;
 - (e) Placement of sign not to restrict egress from parked cars and not over curb line;
 - (f) Shall be maintained in good condition;
 - (g) Shall not be attached to any public utility pole, street light standard or tree;
 - (h) Shall be non-illuminated; and
 - (i) There shall be an annual renewal permit fee, as established under the Code of Ordinances.
- (4) One (1) free-standing business or identification sign per street frontage, per development, shall be permitted. A maximum of two (2) free-standing signs per development shall be deemed as primary, not exceeding seventy-five (75) square feet per sign. All other free-standing signs shall be considered secondary, and shall not exceed forty (40) square feet per sign. Such signs may be located in or adjacent to the right-of-way (in the median or at each side of the street), subject to written authorization of the Commissioner of Public Works & Development, who shall determine that the signs would not be located in the sight triangle and would not cause a hazard to traffic. Proof of permanent maintenance and an encroachment permit shall be provided by the applicant prior to the issuance of a permit for such a sign located in the right-of-way.
- (5) One (1) project identification sign per building, per street frontage, shall be permitted, not to exceed five percent (5%) of the wall area to which it is attached. Such projecting sign shall extend no lower than eight (8) feet, with a maximum projection from the wall of the building of no more than four (4) feet.
- (6) In addition, and within a designated Entertainment Mixed-Use Project only:
- (a) In conjunction with an indoor theater: one marquee, not to exceed twenty-four (24) square feet, shall be permitted per theater. Such marquee shall project no more than eight (8) feet from the building face to which it is attached and shall have a minimum clearance of eight (8) feet. In addition, one attraction board per theater may be attached either to one free-standing business sign or to the marquee, not to exceed twenty-four (24) square feet.

17-7(q) EXPANSION AREA ZONES

- (1) CONSERVATION DISTRICT (CD), EXPANSION AREA RESIDENTIAL (EAR-1, EAR-2 and EAR-3) and COMMUNITY CENTER (CC) ZONES - Signage shall be permitted and restricted under Article 17-7(m), as for a PUD zone. Construction screening signs shall be permitted within a CC zone as regulated in the B-1 zone.
- (2) ECONOMIC DEVELOPMENT (ED) ZONE - Signage shall be permitted and restricted as in the P-1 zone, except as follows:
- (a) Project entrance identification signs shall be for Professional Office Projects, as specifically regulated under Section 17-7(e)(10). All free-standing identification or business signs shall be monument type.
 - (b) Signage for extended-stay hotels may be directly, indirectly or internally illuminated. There shall be no more than one (1) wall-mounted business sign per each extended-stay hotel, not to exceed thirty-two (32) square feet in area; and no more than one (1) free-standing monument type business sign, eight (8) feet in height, with a maximum size of thirty-two (32) square feet.

17-8 VARIANCES

17-8(a) AUTHORITY OF THE BOARD OF ADJUSTMENT - The Board of Adjustment shall have the authority to hear and decide on applications for variances to the dimensional requirements contained therein in accordance with Article 7 of this Zoning Ordinance. The Board shall not be authorized to increase the number of permitted signs; and may not permit any sign to be erected or mounted, to incorporate any design feature, information, or copy, nor to permit a design type that is not specifically permitted in the zone in which the sign is to be located; nor to grant any variance which would increase the maximum total permitted sign area on a single lot or building.

17-8(b) FINDINGS REQUIRED FOR VARIANCES - Before granting a variance to the dimensional requirements for a sign, the Board shall find all of the following, which shall be recorded along with any imposed conditions or restrictions in the minutes and records and issued in written form to the applicant to constitute proof of the variance:

- (1) The requested variance arises from special circumstances which do not generally apply to land in the general vicinity or in the same zone.
- (2) The strict application of the provisions of the sign regulations of this Zoning Ordinance would deprive the applicant of a reasonable use of the land or would create unnecessary hardship on the applicant.
- (3) Such special circumstances are not the result of actions of the applicant taken subsequent to the adoption or amendment of the sign regulation of this Zoning Ordinance.
- (4) Reasons that the variance will not adversely affect the public health, safety and welfare, and will not alter the essential character of the general vicinity, and will not cause a hazard or a nuisance to the public.

17-9 NON-CONFORMING SIGNS - A legal non-conforming sign may continue in existence and shall be properly maintained in good condition. These sign regulations shall not be construed to prevent the strengthening, repair, or restoring to a safe condition of any sign; but a non-conforming sign shall not be:

- (a) changed to another non-conforming sign; except where only the faces or the messages are changed, or where the sign is reduced in height, size or area;
- (b) structurally altered (except to meet safety requirements) so as to prolong the life of the sign;
- (c) altered so as to increase the degree of non-conformity of the sign;
- (d) expanded or enlarged;
- (e) re-established after its discontinuance for ninety (90) days;
- (f) moved to a new location on the building or lot.

17-10 DISCONTINUANCE OF ILLEGAL SIGNS - Mobile signs prohibited under 17-5(a) are illegal signs and are subject to immediate enforcement action.

17-11 DISCONTINUANCE OF TEMPORARY SIGNS - Any temporary sign erected or displayed more than 90 days prior to the date of passage of this Article shall be removed forthwith.

17-12 SIGNS AS CONDITIONAL USES - The Board of Adjustment shall have the authority to approve conditional uses for signs which are specifically listed in the zone in question. Such signs shall be subject to all provisions and procedures as set forth in Article 7 for a conditional use permit.

17-13 MAINTENANCE STANDARDS - Every sign, including those signs for which a permit is not required, shall be maintained in good condition at all times.

- (a) Any painted wall sign shall be repainted at least once every three (3) years.

- (b) All signs which contain painted parts shall be kept neatly painted, including metal parts which are not galvanized or of rust resistant materials.
- (c) The Division of Building Inspection shall have the authority to order the repair, repainting, alteration or removal of any sign which constitutes a hazard to the health, safety or public welfare or which is an eyesore to the community by reason of inadequate maintenance, dilapidation or obsolescence.

17-14 PENALTIES FOR VIOLATION - Violation of the provisions of these sign regulations shall constitute a misdemeanor; or, in the alternative, may be punishable by the issuance of a civil citation, which shall be subject to the fines and penalties as set forth in Article 5 for violation of this Zoning Ordinance.

Section 10 – That Articles 22A & B of the Zoning Ordinance of the Lexington-Fayette Urban County Government is hereby amended to read as follows:

RESIDENTIAL PLANNED UNIT DEVELOPMENT (PUD-1) ZONE

22A-1 INTENT - The intent of the Residential Planned Unit Development (PUD-1) is to encourage a unified design for large tracts of land in the new growth areas of Lexington-Fayette County, which will be consistent with the residential land use recommendations of the adopted Comprehensive Plan.

22A-2 MINIMUM SITE LOCATION AND SIZE CRITERIA - Application for a map amendment request to a PUD-1 zone shall be made only on property that meets the following criteria:

22A-2(a) LOCATION - The property must be entirely or substantially located within an area recommended for residential (low, medium or high density) use in the adopted Comprehensive Plan.

22A-2(b) MINIMUM SIZE - No site may be zoned to a PUD-1 classification unless it is at least three (3) acres in size. Enlargement of the PUD-1 zone may be permitted, regardless of the size, only if it is found that the enlargement is in accord with the requirements of the PUD-1 zone and that the enlargement would be a harmonious extension of the original design of the PUD-1 zone.

22A-3 PERMITTED USES – The following uses shall be permitted in the PFUD-1 zone. All uses other than those specifically listed as permitted uses or substantially similar to the permitted uses shall be prohibited.

22A-3(a) PRINCIPAL PERMITTED USES – The primary principal permitted uses shall be single family, two family, townhouse, and multi-family dwelling units. In addition the following uses shall be permitted, provided that the aggregate total lot area for such uses does not exceed fifteen percent (15%) of the total lot area of the planned unit development.

1. Kindergartens, nursery schools, day nurseries and child care centers for four (4) or more children. For any lot or property which will also be used for residential purposes no more than twelve (12) children shall be permitted. All kindergartens, nursery schools, day nurseries and child care centers shall provide a fenced and screened play lot which shall contain not less than twenty-five (25) square feet per child.
2. Places of religious assembly
3. Nursing homes and personal care facilities.
4. Schools for academic instruction.

22A-3(b) OTHER PERMITTED USES - Within a planned unit development containing at least one hundred (100) gross acres and not less than six hundred (600) total dwelling units, a restricted commercial use shall be permitted within the PUD-1 zone in conformance with the following provisions:

1. The Commercial area(s) shall be designated on the required development plans. Residential and non-residential uses may be provided within the same structure, provided that such uses are not located on the same floor, or separate entrances are provided.

2. Permitted uses and off-street parking shall be as provided for principal permitted uses in the B-1 zone.
3. The commercial area shall be located on a continuous public collector street, but shall not be closer than 2,000 feet (measured along the collector street) to any principal or minor arterial street.
4. The total land area for the commercial use shall not exceed two (2) acres in size, or one percent (1%) of the gross land area within the planned unit development, whichever is the greater acreage.
5. The commercial area shall be in keeping with the overall design of the planned unit development, provide primarily for the needs of the residents of the development, and visually harmonize with the residential areas within the planned unit development.
6. No building permits may be issued for structures designated for commercial uses until occupancy permits have been issued for at least fifty percent (50%) of the total residential dwelling units contained within the planned unit development.

22A-3(c) ACCESSORY USES - The following uses are permitted when incidental and subordinate to principal permitted uses:

1. Private garages, storage sheds and parking areas.
2. Swimming pools, tennis courts, clubhouses and other private or common use open space and recreational areas.
3. Agricultural uses, excluding commercial stock raising.
4. Home office.

22A-3(d) CONDITIONAL USES - Home occupations shall be the only conditional use permitted upon approval by the Board of Adjustment.

22A-4 CONTENT AND FORMAT OF REQUIRED APPLICATION MATERIALS – the following provisions shall be applicable for materials required for the processing of applications for approvals within the PUD-1 zone.

22A-4(a) AUTORIZATION TO PREPARE REQUIRED MATERIALS - In order to ensure that the Planned Unit Development Plan has been prepared in a professional manner using a multi-discipline approach the preliminary Planned Unit Development Plan shall be certified by two or more of the following professionals:

- (1) An urban planner who is a full member of AICP.
- (2) A landscape architect license to practice in the State of Kentucky.
- (3) An architect registered to practice in the State of Kentucky.
- (4) A civil engineer registered to practice in the State of Kentucky.

The final planned unit development plan shall be certified by a civil engineer registered in Kentucky and one or more of the professionals listed in (1), (2) or (3) above.

22A-4(b) MAP AMENDMENT REQUEST MATERIALS - Any map amendment request to a PUD-1 zone shall be filed in such form and such materials as required by Article 6 of this Zoning Ordinance and the bylaws of the Planning Commission. In addition, a preliminary Planned Unit Development Plan, a site inventory, and any proposed restrictive covenants, including homeowners' association documents, shall be included with the application as the minimum requirements for filing.

22A-4(b)(1) REQUIRED PLANNED UNIT DEVELOPMENT PLANS - Shall comply with the informational and design requirements for preliminary or final development plans under Article 21 of this Zoning Ordinance.

22A-4(b)(2) SITE INVENTORY - The required site inventory shall be a separate document from the required Planned Unit Development Plan. The inventory shall include text and map information indicating soil types and their locations and development limitations; existing drainage features including watercourses, natural swales, ponds, floodplains, etc.; existing vegetative cover, including tree stands and the general type and size of trees, any existing utilities on site; the location and use of any existing structures on the site; identification and location of any historic structures or other natural or man-made features of historic interest; any existing easements; and any other significant site features.

22A-4(b)(3) RESTRICTIVE COVENANT - Any proposed restrictive covenants or homeowners' association documents shall be provided in triplicate in a recordable form.

22A-5 REVIEW PROCEDURES - All applications for a PUD-1 shall be reviewed under the following procedure. The applicant may request recommendations from the Division of Planning at any point in the review process and make changes so that the revisions can be submitted to the remaining review groups.

22A-5(a) PRE-APPLICATION CONFERENCE - A pre-application conference as set forth in Article 6 shall be required prior to the submission of a map amendment request to a PUD-1 zone. At the conference a sketch plan and a preliminary site inventory shall also be presented.

22A-5(b) FILING - To formally request Planning Commission action on the map amendment to a PUD-1 zone, the applicant shall submit to the Division of Planning a completed application form, all materials as required herein and a fee as required by the Commission's adopted filing and fee schedule.

22A-5(c) TECHNICAL COMMITTEE - The Division of Planning and other concerned agencies shall review the submitted materials and meet together as a Technical Committee to discuss the technical aspects of the physical design elements of the proposed development and to delineate and try to resolve any conflicts. The Technical Committee shall make recommendations that shall be utilized in preparation of the staff's recommendation to the Commission's Zoning and Subdivision Committees.

22A-5(d) STAFF RECOMMENDATION - The Division of Planning shall review all land use and physical design elements of the PUD-1 proposal for compliance with the provisions and intent of this Article, and shall prepare a written report, including recommendations, for consideration by the Commission's Zoning and Subdivision Committees. The staff report shall also be included in information forwarded to the full Commission and Council.

22A-5(e) SUBDIVISION COMMITTEE - The Subdivision Committee shall review the recommendations of the staff and shall evaluate the map amendment request to determine its compliance with the requirements of the PUD-1 zone. The Subdivision Committee shall give special consideration to the physical design aspects of the development proposal in making its recommendation to the Commission.

22A-5(f) ZONING COMMITTEE - The Zoning Committee shall review the recommendations of the staff and shall evaluate the map amendment request to determine its compliance with the requirements of the PUD-1 zone. The Zoning Committee shall give special consideration to the land use aspects of the application but shall consider all aspects of the development proposal in making its recommendation to the Commission.

22A-5(g) PLANNING COMMISSION - The Planning Commission shall conduct a public hearing on the zone map amendment following the Commission procedure as set forth in Article 6 and shall vote to recommend approval, conditional approval or disapproval of the proposed map amendment within ninety (90) days of the date of filing unless the applicant agrees to a longer time period. The Commission shall review all submitted material and may recommend approval only if it is found that all materials including the preliminary Planned Unit Development Plan comply with the requirements and the intent of the PUD-1 zone.

22A-5(h) URBAN COUNTY COUNCIL - Upon receiving the written report from the Commission, the Council may adopt the recommendation of the Commission without a public hearing or may elect to hold a new public hearing in conformance with Article 6 of the Zoning Ordinance. In either case, the Council shall review the recommendation of the Commission, the staff and the submitted materials (preliminary planned unit development plan, inventory, etc.), and shall base its decision to approve or deny the proposed map amendment upon the materials submitted and their compliance with the intent and requirements of the PUD-1 zone.

If the Council elects to hold a new public hearing, it may also consider any materials or information submitted at the public hearing in making its decision. If it so desires, the Council may, upon holding a public hearing, declare certain aspects of the preliminary Planned Unit Development Plan as only being permitted to be changed on the final Planned Unit Development Plan, or subsequent amendments, with the approval of the full Council. Such declarations may take the form of specific restrictions or may be parameters within which subsequent plans may deviate from the approved preliminary Planned Unit Development Plan. For all plans where no such declaration is made, or where subsequent plans conform to the declarations or where the Council does not hold a new public hearing on the map amendment, no further action by the Council shall be required.

22A-5(i) CERTIFICATION OF THE PRELIMINARY PLANNED UNIT DEVELOPMENT PLAN - Within six (6) months of the Council's action to approve a PUD-1 zone, unless a time extension has been granted, the following steps shall be completed:

- (1) The applicant shall submit a completed and corrected tracing of the preliminary Planned Unit Development plan to the Division of Planning. This plan shall include any restrictive notes required by the Commission or agreed to by the applicant at public hearings.
- (2) The preliminary Planned Unit Development Plan shall be certified by the Commission's Secretary if it is in conformance with all requirements.

Required copies of the tracing shall be made by the Division of Planning at the applicant's expense. If the requirements listed above have not been met within six (6) months, the staff shall notify the Commission and the Council, and either may initiate a map amendment to the previous zone or other appropriate zone. The Commission shall have authority to grant a time extension or to re-approve an expired plan. The Commission may require changes in the development plan where it is found that time has necessitated such changes for the health, safety or welfare of the community.

22A-5(j) EFFECT OF APPROVAL OF THE PRELIMINARY PLANNED UNIT DEVELOPMENT PLAN - No construction may commence on any project based upon approval of the preliminary Planned Unit Development Plan. Approval of the preliminary Planned Unit Development Plan authorizes the developer to proceed with preparation of the final Planned Unit Development Plan. No final Planned Unit Development Plan shall be accepted as filed unless and until the preliminary Plan has been certified.

22A-5(k) FINAL PLANNED UNIT DEVELOPMENT PLAN - Within two (2) years of the Council's approval of the zone map amendment, a final Planned Unit Development Plan shall be submitted to the Division of Planning. The review procedure for the final Planned Unit Development Plan shall be the same as for the preliminary with the following exceptions:

- (1) The map amendment related filing materials and site inventory shall not be required.
- (2) The approval of the Urban County Council shall not be required.

22A-5(l) CERTIFICATION OF THE FINAL PLANNED UNIT DEVELOPMENT PLAN - Within six (6) months of the Commission's action the following steps shall be completed: The applicant shall fully comply with all conditions of the Commission and any restrictions agreed to by applicant at the Council's public hearing, and shall submit the completed tracing of the final Planned Unit

Development Plan to the Division of Planning; the final Planned Unit Development Plan shall be certified by the Commission's Secretary if it is in conformance with the Commission's and Council's requirements. Required copies of the tracing shall be made by the Division of Planning at the applicant's expense.

If the requirements listed above have not been met within six (6) months, the staff shall notify the Commission and the Council and either may initiate a map amendment to the previous zone or other appropriate zone. The Commission shall have the authority to grant a time extension or to re-approve an expired plan, unless Council reserves authority for approval of the plan, in which case the Council shall have final authority. Either body may require changes in the plan where it finds that time has necessitated such changes for the health, safety or welfare of the community.

22A-5(m) EFFECT OF APPROVAL OF THE FINAL PLANNED UNIT DEVELOPMENT PLAN - Upon certification and recordation of the final Planned Unit Development Plan, the developer shall be authorized to do the following:+

- (1) PREPARATION OF IMPROVEMENT PLANS - The approval and certification of the final Planned Unit Development Plan shall have the same effect as approval of a preliminary subdivision plan. The applicant may proceed to prepare improvement

plans in conformance with the requirements for preparation and review of such plans contained within the Land Subdivision Regulations.

(2) PREPARATION OF FINAL SUBDIVISION PLAN - A Final Subdivision Plan shall be required for all planned unit developments. Such plan shall be prepared, reviewed, and recorded in conformance with the requirements for Final Subdivision Plans contained within the Land Subdivision Regulations. Any restrictive covenants, or other restrictive notes required by the Commission or agreed to by the applicant at the Council's public hearing shall be shown or referenced on the final subdivision plan.

(3) ISSUANCE OF BUILDING PERMITS - Upon certification of the final Planned Unit Development Plan and recording of the Final Subdivision Plan, the Division of Planning shall forward copies to the Division of Building Inspection which may issue permits in accord with the approved final Planned Unit Development Plan and the Final Subdivision Plan. The plans shall limit and control the issuance of all building and occupancy permits and restrict the construction, location and use of all land and structures to the conditions set forth in the plans.

22A-5(n) AMENDMENTS TO FINAL PLANNED UNIT DEVELOPMENT PLANS - Amendments to final Planned Unit Development Plans shall require the same information and shall be reviewed and processed in accordance with the requirements and design standards contained herein for the original plan submission, except that amendments which meet the definitions of minor amendments under Article 21-7 of the Zoning Ordinance may be approved by the Division of Planning in accordance with the procedures contained within Article 21-7.

22A-6 DESIGN STANDARDS - The following design standards and criteria shall be applicable in the PUD-1 zone:

22A-6(a) DWELLING UNIT DENSITY - The overall gross dwelling unit density within the planned unit development shall not exceed the recommendations contained within the adopted Comprehensive Plan.

22A-6(b) MINIMUM LOT SIZE - Except for the minimum total area requirement of three (3) acres under Section 22A-2, there shall be no minimum or maximum lot size dictated within this Article for the PUD-1 zone. However, the required development plans shall indicate lot sizes; and through the review and approval process, restrictions for minimum, and where appropriate, maximum lot sizes for the entire planned unit development, or defined areas within it, shall be established.

22A-6(c) PERIMETER YARD REQUIREMENTS - A minimum height-to-yard ratio of 1:1 for principal and accessory structures shall be required along the outside perimeter boundary of the planned unit development.

22A-6(d) ALL OTHER YARDS - There shall be no minimum setbacks or other yard requirements dictated within this Article for the PUD-1 zone other than those required through the Building and Fire Codes and a minimum required front yard of ten (10) feet along any continuous public collector street. However, the required development plans shall indicate proposed yard requirements, and through the review and approval process, restrictions on yards for the entire planned unit development or defined areas within it shall be established.

22A-6(e) USABLE OPEN SPACE - Within a planned unit development, not less than thirty percent (30%) of the gross land area shall be restricted to usable open space.

22A-6(f) BUILDING COVERAGE - The maximum building coverage shall not exceed thirty percent (30%) of the gross land area of the planned unit development.

22A-6(g) FLOOR AREA RATIO - The maximum floor area ratio shall not exceed 1:1, based upon the gross land area of the planned unit development.

22A-6(h) OFF-STREET PARKING - Off-Street parking shall be provided as follows:

Single family, two-family and townhouse dwellings: One (1) space per dwelling unit.

Multi-family dwellings: One and one-half (1½) spaces per dwelling.

Nursery schools, day nurseries and child care centers: Three spaces for the first twelve (12) children plus one (1) space for every ten (10) (or fraction thereof) additional children.

One (1) space for every five (5) seats in the main auditorium.

Places of Religious Assembly – One (1) space for every five (5) seats in the main auditorium.

Nursing homes and personal care facilities: One (1) space for every four (4) beds plus one (1) space for each employee on the maximum working shift with a minimum of five (5) spaces.

22A-6(i) DESIGN AND IMPROVEMENT STANDARDS - All standards contained within Article 6 of the Land Subdivision Regulations shall be applicable to any planned unit development. The standards for street width, curb, gutter and sidewalks (but not the paving specifications) may be waived or modified for local streets where it is found that the planned unit development provides innovative design alternatives in keeping with the intent of the PUD zones and the intent of the PUD-1 zone and still achieves the basic objectives of the Land Subdivision Regulations.

22A-6(j) RELATIONSHIP TO THE SITE INVENTORY - The design of the planned unit development shall respond to the natural and manmade features of the site. The design shall not necessitate excessive grading, filling, the destruction or other alteration of the natural features. Where possible, the streets should follow the natural terrain. The design shall provide adequately for any historic feature on the site as well as any existing structure which is to be retained. The applicant shall use the flexibility of the PUD-1 zone to preserve such desirable natural and man-made features to the greatest feasible extent.

22A-6(k) RELATIONSHIP TO THE TRAFFIC NEEDS OF THE AREA - The planned unit development shall provide a road system which will be adequate to serve both the residents of the PUD-1 zone and the surrounding residents. The design shall provide for the continuation of existing or dedicated streets on adjoining or nearby tracts and provide for connection to adjoining unsubdivided tracts, especially those which would otherwise be landlocked. Collector streets as designated in the Comprehensive Plan shall be extended as shown therein.

22A-6(l) RELATIONSHIP TO THE SURROUNDING LAND USES - The planned unit development zone shall have a harmonious relationship to the surrounding land uses. Certain uses may be limited to specified locations within the PUD-1 zone or other restrictions or requirements may be made as necessary.

22A-6(m) ADEQUACY OF LIGHT, AIR AND OPEN SPACE - The design of the planned unit development shall provide for adequate light to each dwelling unit during all seasons of the year. The Commission may require a winter shadow plan to be submitted prior to making a recommendation or decision on the PUD-1 zone. Usable open space shall be distributed throughout the site so that open space is readily available to each unit. The dwelling units shall be arranged in relationship to each other and the terrain so that adequate ventilation is provided to each unit.

22A-6(n) APPLICABILITY OF OTHER ZONING ORDINANCE AND SUBDIVISION REGULATION ARTICLES - Except as specifically modified herein, all other provisions of the Zoning Ordinance and Subdivision Regulations generally applicable to development in the Lexington-Fayette Urban County shall be applicable within the PUD-1 zone.

22A-6(o) MAINTENANCE OF COMMON AREAS - Where the design of the Planned Unit Development indicates a need or desire to subdivide property and to provide for common areas, a Homeowners' Association, or other mechanism for the provision of maintenance, improvement, and operations for all common areas including streets, parking areas, open space, etc., shall be required to be established by the applicant. The applicant's responsibility to create such a mechanism shall be noted on the development plan of the Planned Unit Development. A requirement that each property owner be individually responsible for maintenance of the common space abutting the lot shall not be considered as acceptable for fulfilling the requirements of this section.

22A-6(p) INNOVATIVE DESIGN - The planned unit development shall utilize a design or arrangement of unit types which would not be customary using traditional techniques. While some units or buildings may be arranged in a traditional manner, the overall design should reflect the intent of the PUD zones as well as comply with all requirements and the intent of the PUD-1 zone.

22A-7 TIMING OF DEVELOPMENT - Within five (5) years of the approval of the final Planned Unit Development Plan, unless an extension of the time period is granted, the applicant shall be required to obtain building permits for all structures shown thereon. No permits for unconstructed buildings may be issued after that date based on the final Planned Unit Development Plan. The applicant may submit a new final plan for review or may request that the previous plan be re-evaluated to determine if time has necessitated changes in the plan for the health, safety, or welfare of the community. In either case, the procedure for submission and review shall be as required for a final planned unit development plan contained herein.

LUIGART PLANNED UNIT DEVELOPMENT (PUD-2) ZONE

22B-1 INTENT - The intent of the Luigart Planned Unit Development (PUD-2) is to:

1. Implement the recommendations of the 2009 Central Sector Small Area Plan and the 2011 North Limestone Sustainability Plan.
2. Promote the innovative reuse and redevelopment of an older, mixed-use neighborhood in the urban core of Lexington-Fayette County, which is consistent with the Goals and Objectives of the Comprehensive Plan.

This Planned Unit Development zone is established to support infill and redevelopment that maintains neighborhood character, preserves housing affordability and strengthens opportunities for new applied arts and skilled crafts businesses and jobs, which are vital to the 21st century economy of Lexington-Fayette County. Live/Work districts such as this Planned Unit Development zone provide a desirable housing option to creative professionals and a benefit to the surrounding community when located so as to be compatible with existing uses. The Planned Unit Development-2 (PUD-2) is hereby created to accompany lands located between North Limestone Street (to the west), Maple Street (to the east), the R.J. Corman Rail Line (to the north) and West Seventh Street (to the south); and the regulations hereunder shall be established in addition to the applicable regulations contained in this Zoning Ordinance. Where there are conflicts between the regulations hereunder, and those contained elsewhere in the Zoning Ordinance, the use, dimensions and other requirements hereunder shall apply.

22B-2 RELATIONSHIP TO THE COMPREHENSIVE PLAN - This PUD-2 zone is based upon furthering the goals, objectives and land use policies of the 2013 Comprehensive Plan for the Lexington-Fayette Urban County Government (including the 2009 Central Sector Small Area Plan) and the 2011 North Limestone Sustainability Plan.

22B-3 DEFINITIONS - As used in this Article, the following terms shall have the meaning given herein; otherwise, definitions of Article 1 shall apply:

1. Live/Work Space - A dwelling unit that is also used for non-residential uses permitted herein such as, but not limited to: the production, showing and sale of art; both visual and performing arts; office uses and related uses.
2. Artist Studio - A studio working in all art forms, including, but not limited to: painters; sculptors; authors; screenwriters; playwrights; filmmakers; dancers; potters; weavers; jewelers; exhibitors; printers; costumers; musicians and photographers.
3. Artisan Food and Beverage Production - On-site production of food and beverage products, involving small batch processing. Typical uses include, but are not limited to: coffee roasting; ice cream; baker, candy and other foodstuffs; and alcoholic beverage manufacturing. This may include on-site sales and consumption.
4. Artisan Manufacturing - On-site production of goods by hand manufacturing, involving the use of hand tools and small-scale, light mechanical equipment. Typical uses include, but are not limited to: wood working; ceramic studios; jewelry manufacturing; and uses that have no negative external impacts on surrounding properties. Welding is also permitted.
5. Digital Makerspace - A facility for digital design and fabrication utilizing hardware and software tools.
6. Urban Agriculture - The production and distribution, including on-site sales, in an urban neighborhood of agricultural or horticultural crops, including, but not limited to: poultry; poultry products; grain; hay; pastures; soybeans; timber; orchard fruits; vegetables; flowers or ornamental plants. This use does not include livestock or livestock products.
7. Visiting Artist Housing - A dwelling unit or living quarters made available for visiting artists that may be rented or occupied for less than one week at a time. A maximum of one such housing unit shall be permitted per lot.
8. Accessory Dwelling Unit (ADU) - A separate and complete dwelling unit that is contained on the same lot as the structure of a single-family dwelling or business. Such a dwelling unit shall be clearly incidental and subordinate to the principal use of the lot.

22B-4 MINIMUM SITE LOCATION - Application for a map amendment request to a PUD-2 zone shall be made only on property that meets the following criteria:

22B-4(a) LOCATION - The property must be entirely or substantially located within an area between North Limestone Street (to the west), Maple Street (to the east), the R.J. Corman Rail Line (to the north) and West Seventh Street (to the south).

22B-5 PERMITTED USES - The following uses shall be permitted in the PUD-2 zone. All uses other than those specifically listed as permitted uses or substantially similar to the permitted uses shall be prohibited.

22B-5(a) PRINCIPAL PERMITTED USES

1. Live/Work space.
2. Dwelling units.

3. Artist studios.
4. Artisan food and beverage production.
5. Artisan manufacturing.
6. Digital makerspace.
7. Urban agriculture.
8. Visiting artist housing.
9. Libraries, museums, art galleries and reading rooms.
10. Community centers.
11. Places of religious assembly.
12. Indoor theaters.
13. Tattoo parlors.
14. Shoe repair, clothing alterations and tailoring services.
15. Beauty shops and barber shops.
16. Radio and television studios.
17. Banks and financial institutions, without drive-through facilities.
18. Offices for business, professional, governmental, civic, social, fraternal, political, religious and charitable organizations.
19. Establishments for the retail sale of food products.
20. Establishments for the retail sale of merchandise as permitted in the B-1 zone, unless prohibited by Section 22B-5(d).
21. Common use open space and recreational areas.

22B-5(b) ACCESSORY USES - The following uses are permitted when incidental and subordinate to principal permitted uses:

1. Private garages, off-street parking areas and storage sheds, only if accessory to a principally permitted use which does not contain a principal structure; such as, but not limited to, an Urban Agriculture use.
2. Swimming pools, tennis courts, clubhouses and other private or common use open space and recreational areas.
3. Private, non-commercial parks and open space.
4. A ground-mounted satellite dish antenna, as regulated by Article 15-8.
5. Family child care for up to six (6) children, provided that the total number of children living or being cared for on the property shall not exceed six.
6. One or two pool or billiard tables within an establishment.
7. Sale of finished products related or incidental to the principal use.
8. Accessory dwelling units.
9. Temporary structures designed for use or occupancy for up to 60 days per 12-month period on a single property, calculating said period by cumulative consideration of the use of any and all such structures on a single property.
10. Sidewalk cafes, when accessory to any permitted restaurant.

22B-5(c) CONDITIONAL USES - Permitted only with Board of Adjustment approval.

1. Parking areas.
2. Family child care for seven (7) and not more than twelve (12) children. A fenced outdoor play area shall be provided, which shall contain not less than twenty-five (25) square feet per child.
3. Restaurants and brew-pubs, except as prohibited under Sections 8-16(e)(14) and (15). This does not include drive-in restaurants.
4. The sale of malt beverages, wine or alcoholic beverages, when accessory to a restaurant permitted herein.
5. Indoor or outdoor live entertainment and/or dancing, when accessory to a restaurant or brew-pub. Indoor uses shall be sound-proofed to the maximum extent feasible by using existing technology, with noise or other emissions not creating a nuisance to the surrounding neighborhood. The Board may also impose time and other restrictions to minimize nuisance to the surrounding neighborhood.
6. Cocktail lounges or nightclubs unless prohibited under Sections 8-16(e)(14) and (15).
7. Temporary structures designed for use or occupancy for 61-180 days per 12-month period on a single property, calculating said period by cumulative consideration of the use of any and all such structures on a single property.
8. Retail sales not otherwise permitted herein.
9. Private clubs or banquet facilities.
10. Kindergartens, nursery schools, day nurseries and child care centers for four (4) or more children. For any lot or property which will also be used for residential purposes, no more than twelve (12) children shall be permitted. All kindergartens, nursery schools, day nurseries and child care centers shall provide a fenced outdoor play area, which shall contain not less than twenty-five (25) square feet per child.

22B-5(d) PROHIBITED USES - All uses other than those listed as principal, accessory or conditional uses, or substantially similar to principal, accessory or conditional uses shall be prohibited. The uses below are provided for illustration purposes and for the purpose of limiting permitted uses, and are not intended to be a total listing of all the uses that are prohibited.

1. Drive-through facilities.
2. Beer, liquor and wine stores.
3. General contractors, such as plumbing; heating; carpentry and cabinet shops; masonry; plastering; electrical; tile and terrazzo work; electroplating; drilling; excavating; wrecking; construction and paving. This is not intended to prohibit the administrative offices of such.

22B-6 DESIGN STANDARDS - The following design standards and criteria shall be applicable in the PUD-2 zone. All new structures and alterations or additions to existing structures shall be constructed to a height, scale, proportion and gross volume compatible with the existing structures that are within 200 feet or are substantially related to them visually. The existing rhythm created by existing building masses and spaces between them should be preserved.

The following table shall establish what standards and what process is required for each project or parcel. If all of the standards of Column A can be met by the applicant and/or property owner, then no development plan shall be required. If any one or more of the standards in Column A cannot be met by the applicant and/or property owner, then the standards established in Column B shall apply, and a development plan shall be required to be filed for consideration by the Planning Commission or by the Division of Planning staff under the provisions of Article 21-7 herein.

	<u>Column A</u>	<u>Column B</u>
	Without Development Plan Approval	With Development Plan Approval
Lot Coverage	50%	100%
Maximum Vehicular Use Area (VUA) Coverage	30%	50%
Building Height	Average of Principal Structures on Immediately Adjoining Lots	75 Ft.
Lot Size	Max: 7,500 Sq. Ft.	No Maximum
Floor Area Ratio (FAR)	0.5	2.0
Yards		
Front	Min: 7 Ft.	No Minimum
	Max: 20 Ft.	Max: 20 Ft.
Side	No Minimum	No Minimum
Rear	No Minimum	No Minimum

Side Street Side	½ the established Front Yard
Open Space	None Required
Signage	As permitted in 17-7(o)

22B-6(a) OFF-STREET PARKING - No off-street parking shall be required except for where the Planning Commission or Board of Adjustment may establish off-street parking requirements, as needed.

22B-6(b) VARIANCES - Requests for variances to the dimensional requirements of Article 22B will only be considered for the standards established above in Column B.

22B-7 REVIEW PROCEDURES - All applications for a PUD-2 shall be reviewed under the following procedure:

22B-7(a) AUTHORIZATION TO PREPARE REQUIRED MATERIALS - In order to ensure that the Planned Unit Development Plan has been prepared in a professional manner using a multi-discipline approach, it shall be certified by an architect registered to practice in the State of Kentucky and one or more of the following professionals:

- (1) An urban planner who is a full member of AICP.
- (2) A landscape architect licensed to practice in the State of Kentucky.
- (3) A civil engineer registered to practice in the State of Kentucky.

22B-7(b) MAP AMENDMENT REQUEST - Any map amendment request to a PUD-2 zone shall be filed in such form and such materials as required by Article 6 of this Zoning Ordinance and the bylaws of the Planning Commission. In addition, a site inventory and analysis shall be included with the application as the minimum requirements for filing.

22B-7(b)(1) SITE INVENTORY - The inventory shall include text and map information indicating existing vegetative cover, including tree stands and the general type and size of trees; any existing utilities on site; the location and use of any existing structures on the site; identification and location of any historic structures or other natural or man-made features of historic interest; any existing easements; and any other significant site features. When a Planned Unit Development Plan is required, the inventory shall also include soil types and their locations and development limitations; and existing drainage features, including watercourses, natural swales, ponds, floodplains, etc.

22B-7(b)(2) SITE ANALYSIS AND RECOMMENDATIONS - Based on the site inventory information, a Site Analysis, including recommendations, shall be provided. The Site Analysis may recommend public infrastructure improvements, uses, scale and context, in keeping with the stated intent of the PUD-2 zone.

22B-7(c) PLAN AND PERMIT PROCESS - Shall be as follows:

22B-7(c)(1) ISSUANCE OF A ZONING COMPLIANCE PERMIT - When a property meets all of the requirements of the table in Section 22B-6, Column A, the Division of Planning is authorized to issue a Zoning Compliance permit without a Planned Unit Development Plan.

22B-7(c)(2) PLANNED UNIT DEVELOPMENT PLAN - A Planned Unit Development Plan shall be required when a property does not meet the requirements of Section 22B-7(c)(1). When a Planned Unit Development Plan is required, the requirements of the table in Section 22B-6, Column B, shall apply. The content and review process for the Plan shall follow Article 21. Zoning Compliance and other applicable permits may be issued once certification of the Planned Unit Development Plan is complete.

22B-7(c)(3) RELATIONSHIP TO THE SITE INVENTORY - The design of the Planned Unit Development shall respond to the natural and manmade features of the site. The design shall not necessitate excessive grading, filling, or the destruction or other alteration of the natural features. Where possible, the streets should follow the natural terrain. The design shall provide adequately for any historic feature on the site, as well as any existing structure which is to be retained. The applicant shall use the flexibility of the PUD-2 zone to preserve such desirable natural and man-made features to the greatest feasible extent.

22B-8 APPLICABILITY OF OTHER ZONING ORDINANCE AND SUBDIVISION REGULATION ARTICLES - Except as specifically modified herein, all other provisions of

the Zoning Ordinance and Subdivision Regulations generally applicable to development in the Lexington-Fayette Urban County shall be applicable within the PUD-2 zone.

Section 11-That Article 23, and Appendix 23A, 23B, and 23C of the Zoning Ordinance of the Lexington-Fayette Urban County Government is hereby amended to read as follows:

EXPANSION AREAS ZONING CATEGORIES AND RESTRICTIONS

23-1 PURPOSE - As a part of adoption of the Comprehensive Plan, the Planning Commission adopted an Expansion Area Master Plan (EAMP) element, which sets forth provisions to guide growth within designated Expansion Areas (EA) to Lexington-Fayette County's Urban Service Area. The Expansion Area Master Plan is intended to establish a new approach to development coordination and regulation than has been previously used within the existing Urban Service Area. The Expansion Area Master Plan encourages innovative design and a range of uses which are integrated into the development; encourages development which is sensitive to the topographic features and the unique rural character of the Bluegrass; encourages the new development within the Expansion Area to function as a "community" with a mix of uses, housing types and land for economic development and community facilities, including parks, public facilities, and community centers. The purpose of this Article and its appendices is to provide the necessary implementing regulations to achieve the goals of the Expansion Area Master Plan.

23-2 GENERAL PROVISIONS - Within the Expansion Areas, the following provisions shall be applicable to all properties as appropriate:

23-2(a) APPLICABILITY - Except as specifically modified by the provisions of this Article, all other provisions of the Zoning Ordinance shall be applicable to the Expansion Areas.

23-2(b) EXISTING AGRICULTURAL USES NOT NON-CONFORMING USES - Agricultural uses of land or agricultural uses of buildings or structures which were lawful prior to the adoption of the Expansion Areas Zoning Categories and Restrictions and which would be otherwise prohibited, regulated, or restricted by the provisions of this Article, shall for the purposes of this Article be deemed permitted uses in the zone or district in which they are located and shall not be deemed non-conforming.

23-2(c) EXISTING LOTS AND EXISTING RESIDENTIAL USES - Notwithstanding any provision of this Article, any lot which was in existence at the time of the adoption of these Expansion Areas Zoning Categories and Restrictions may be used for one (1) single family house and permitted accessory uses with lot, yard and height as in the Agricultural Rural (A-R) Zone as a principal or accessory use, as appropriate.

23-2(d) ZONING CATEGORIES PERMITTED - The only zoning categories to be permitted within the Expansion Areas shall be those expressly created in Appendix 23A. The only exception to this requirement shall be that the Lexington-Fayette Urban County Government, in conjunction with a government sponsored comprehensive rezoning of the Expansion Area, may opt for developed land to keep the zoning in existence at the time of adoption of this Article in place if it finds such action to be in the best interest of furthering the goals of the Expansion Area Master Plan. Likewise, the zoning categories created herein shall only be utilized within the Expansion Areas, and shall not be permitted within other areas of Fayette County, except in conformance with any future amendments to the Comprehensive Plan.

23-3 INTERPRETATIONS AND DEFINITIONS - The provisions of this Article shall be construed so as to liberally carry out its purpose in the interest of protecting the public health, safety and welfare by managing growth and development in the Expansion Areas. For the purposes of administration and enforcement of this Article, the following rules of construction shall apply:

- (a) In case of any difference of meaning or implication between the text of this Article and any caption, illustration, summary table, or illustrative table, the text shall control.
- (b) Unless the context clearly indicates the contrary, where a regulation involves two (2) or more items, conditions, provisions or events connected by the conjunction "and", "or" or "either ... or":
 - (1) "And" indicates that all the connected terms, conditions, provisions or events shall apply;
 - (2) "Or" indicates that the connected items, conditions, provisions or events may apply singly or in any combination;
 - (3) "Either ... or" indicates that the connected items, conditions, provisions or events shall apply singly but not in combination.
- (c) The word "includes" shall not limit a term to the specific example but is intended to extend its meaning to all other instances or circumstances of like kind or character.
- (d) All terms used herein shall have the same meaning as in the Lexington-Fayette Urban County Comprehensive Plan, the other provisions of the Lexington-Fayette Urban County Zoning Ordinance, and the Lexington-Fayette Urban County Land Subdivision Regulations unless otherwise indicated. The following words and phrases are defined for the purposes of this Article (and when used in the Article shall have the defined meaning regardless of whether the term is capitalized in the text):

ACCESSORY DWELLING UNIT - A residential dwelling unit of no more than 700 square feet which is incidental and subordinate to a principal single family attached or detached residential unit of at least 1,600 square feet on the property. Accessory dwelling units shall be permitted to be located within an otherwise permitted accessory structure (subject to any size limitations for such accessory structure) or contained within the principal structure.

ACREAGE, GROSS - The total number of acres within a parcel including land to the centerline of any adjoining right-of way.

ACREAGE, NET DEVELOPABLE - The total number of acres within a parcel proposed for development less the area that is designated as a greenway, or is a public right-of-way, steep slope over 30%, water body, floodplain, sinkhole or sinkhole cluster area or woodlands.

AFFIDAVIT OF DENSITY TRANSFER RIGHTS (DTR) - An affidavit of Density Transfer Rights (DTR) is a sworn, written statement by a property owner which attests that: 1) the property owner owns or has an option to purchase DTR, and 2) that the DTR have not previously been used on the parcel of land from which the Rights have been transferred or on any other parcel of land. For the purposes of this Section, an option to acquire a DTR which is specifically enforceable shall constitute ownership. An Affidavit of DTR shall be in conformance with a form provided by the Division of Planning.

AFFORDABLE HOUSING UNIT - A dwelling unit which is provided for sale to an owner-occupant household with an income which does not exceed 80% of median income (adjusted for family size) for Lexington-Fayette County, or for rent to a household with an income which does not exceed 60% of the median income (adjusted for family size) for Lexington-Fayette County. For the purposes of this Article, a unit shall be deemed affordable to an owner-occupant if the total principal, interest, taxes and insurance does not exceed 36% of the household's income; and a unit shall be deemed affordable to a renter household if the total rent, including any tenant-paid utilities, does not exceed 30% of the household's income.

CERTIFICATE OF DENSITY TRANSFER RIGHTS (DTR) - A Certificate of DTR is a document which is issued by the Lexington-Fayette Urban County Government which attests to the existence of DTR which may be transferred to a particular Receiver Site.

The certificate constitutes an official determination by Lexington-Fayette Urban County Government that particular DTR are eligible for transfer to a specific Receiver Site, subject to approval of a development plan. The Certificate is not an opinion of title by the Lexington-Fayette Urban County Government in regard to the DTR which are proposed to be transferred.

DENSITY TRANSFER RIGHT (DTR) - A residential density development right which is severable from the real property to which it is appurtenant and which is transferable to another parcel within a specific expansion area.

DIRECT VEHICULAR ACCESS - A driveway which allows a motorized vehicle to move from a residential lot on to a public or private way.

EXPANSION AREAS - The land area of Lexington-Fayette County added to the Urban Service Area under the provisions of the adopted Expansion Area Master Plan and more specifically designated as EA-1, EA-2A, EA-2B, EA-2C and EA-3; as applied to density transfers and exactions as set forth herein, each of the five designated Expansion Areas shall be considered distinct and separate.

EXPANSION AREA MASTER PLAN (EAMP) - An element of the Lexington-Fayette Urban County Government's Comprehensive Plan adopted by the Planning Commission on July 18, 1996, including any duly approved subsequent amendment. As used in this Article, the term shall also be construed to extend to any other Comprehensive Plan element expressly and directly applicable to the Expansion Areas.

FENCE, STONE - A fence either built of quarried or dressed rocks; or from rocks which have been gathered from fields or creek bottoms; or of undressed ledge or quarried rock.

FENCE, TRANSPARENT - A fence which has at least 60% of its surface area open, and allows the free and unobstructed passage of light.

GREENWAY - Land designated as a greenway in the Expansion Area Master Plan.

OPEN SPACE, COMMON - Outdoor area of a lot or tract which is used for outdoor living, recreation, pedestrian access, or plantings, including buffer yards. Such open space shall generally be available for the use and enjoyment of larger groups of persons such as homeowners' associations, tenant associations, the general public and the like; but shall not be construed to include lands purchased by any government entity for public use, such as parks or street rights-of-way.

OPEN SPACE, GENERAL - An area not covered by structures, driveways, parking lots, walkways, streets, or other paved surfaces.

PEDESTRIAN ACCESSWAY - An improved path or sidewalk which is designed for pedestrian movement.

RECEIVER SITE - A parcel of land to which DTR are transferred.

RURAL SCENIC ROADS - A road which is designated as a Rural Scenic Road in the Expansion Area Master Plan.

SCENIC RESOURCE AREA - An area designated and mapped as a Scenic Resource Area in the Expansion Area Master Plan.

SENDER SITE - A parcel of land from which DTR are severed and transferred.

SPECIAL DESIGN AREA - An area designated and mapped as a Special Design Area in the Expansion Area Master Plan.

APPENDIX 23A - ZONING CATEGORIES AND RESTRICTIONS

23A-1 PURPOSE - The purpose of this appendix is to set forth the zoning categories and restrictions for use in the Expansion Areas, and to establish their regulatory content.

23A-2 GENERAL PROVISIONS APPLICABLE IN ALL ZONES - The following provisions shall be applicable in all zones within the Expansion Areas:

23A-2(a) SPECIAL RURAL ROAD ACCESS REQUIREMENTS - In order to protect the unique character of rural roads within the Expansion Areas, no new street or new driveway access shall be permitted to the following roads: DeLong Road in Expansion Area 1 and 2C; northwest side of Walnut Grove Lane in Expansion Area 2A and Deer Haven Lane in Expansion Area 2B; and the southeast side of Chilesburg Road in Expansion Area 2C.

23A-2(b) FENCES - No more than fifty (50) feet of fence which is not a transparent fence or a stone fence shall be located in a single horizontal plane.

23A-2(c) ENVIRONMENTALLY SENSITIVE LAND - Except as provided under 23A-2(d), 23A-2(g), and 23A-2(u) below, any environmentally sensitive areas or geologic hazard areas shall be regulated in accordance with the provisions of Articles 6-11 of the Subdivision Regulations as applicable.

23A-2(d) STEEP SLOPE AREAS - No building or structure shall be located on any land with a slope which is greater than 30%. For areas with slopes between 15% and 30%, the provisions of Article 6-11 of the Land Subdivision Regulations shall be applicable.

23A-2(e) RURAL SERVICE AREA SETBACK - No building or structure other than transparent fences and stone fences shall be located within 100 feet of the Rural Service Area Boundary.

23A-2(f) RURAL SERVICE AREA AGRICULTURAL USE BUFFER YARD - All development shall provide a buffer yard along any boundary of a parcel proposed for development adjacent to land which adjoins the Urban/Rural Service Area Boundary, which is used for agricultural uses and which is not located across an arterial street, which shall be:

1. Fifty (50) feet in width with two parallel fences of not less than six (6) feet in height located along the outermost and innermost boundaries of the buffer yard with barbed wire not less than six (6) feet above ground level or landscaping material along each fence which will prevent persons from climbing onto or over the fence; or
2. One hundred (100) feet in width with a fence of not less than six (6) feet in height located at the innermost boundary of the buffer yard with barbed wire not less than six (6) feet above ground level or landscaping material which will prevent persons from climbing onto or over the fence; or
3. Three hundred (300) feet in width with a fence of not less than four (4) feet in height located along the innermost boundary of the buffer yard with landscaping material which will prevent persons from climbing onto or over the fence; or
4. A buffer yard width as agreed to in the form of a legally recorded covenant by the owner of the land used for agricultural purposes which provides comparable protection to the agricultural use.

23A-2(g) GREENWAYS - All greenways shall be either dedicated to public use or encumbered by a conservation or storm water management easement, and shall be provided with sufficient points of access as necessary to achieve the intent of the Expansion Area Master Plan. No building, structure, or other development shall be permitted in a greenway except for pedestrian and/or bicycle pathways, or structures necessary for storm water management. The greenway shall be at least 100 feet on each side of the centerline of the stream, or 50' in width measured from the edge of the stream banks.

23A-2(h) PEDESTRIAN ACCESSWAYS - All properties shall have access to a pedestrian accessway, and development plans shall provide for connections between residential uses, non-residential uses, greenways, and other pedestrian accessways. The development of any parcel of land, which abuts a land in a CC zone, shall provide a pedestrian accessway directly to the Community Center.

23A-2(i) FRONT YARD DRIVEWAYS - Any driveway within a front yard of a residential dwelling:

1. On any detached dwelling unit, where no enclosed garage is provided, the driveway must extend beyond the front wall of the residence into the side or rear yard for a distance of at least 20 feet. For attached housing, the developer and the Commission are encouraged to find alternative parking schemes within street rights-of-way as an alternative to front yard parking.
2. Where the dwelling is set back from the right-of-way less than 25 feet, the driveway may not access a garage which fronts the street, but may extend to a side or rear facing garage, or a front facing garage located more than 25 feet from the right-of-way.
3. Where the residence is set back 25 feet or greater, the driveway may access a front facing garage located no closer than 25' from the right-of-way.
4. In any case, the width of a front yard driveway shall not exceed 50% of the width of any lot at the building line as established on the final development plan or final subdivision plan, as appropriate.

23A-2(j) BUILDING AND FENCE RELATIONSHIP TO YARD ABUTTING MAJOR STREET - No residential dwelling shall be developed so that the rear of the structure abuts an arterial or collector street unless the dwelling is located not less than 200 feet from the arterial or collector street. Walls or fences other than transparent fences and stone fences shall only be permitted along the rear of any property abutting an arterial or collector street right-of-way where such are shown on the approved development plan. The Commission shall only approve such walls or fences where they are designed and planned as a part of the overall project, do not create any areas where proper maintenance would be impaired, and would not have the effect of impairing the view of open space areas.

23A-2(k) ACCESSORY STRUCTURES PROHIBITED IN FRONT YARDS - Notwithstanding any other provision of this Article, no accessory structure may be located within any yard area directly between a principal structure and any street except an alley.

23A-2(l) GENERAL LOT, YARD, AND HEIGHT REQUIREMENTS - Shall be as follows:

1. There shall be no minimum lot sizes in any Expansion Area Zone (CD, EAR 1-3, TA, ED, or CC). However, the developer shall establish restrictions for minimum and, where appropriate, maximum lot sizes on the final development plan or the final subdivision plan, as appropriate.
2. With the exception of the setback/yard required to achieve the requirements of the Rural Scenic Roads provisions, Scenic Resource Areas, and Special Design Areas, or other expressly stated yards as established elsewhere in this Article, there shall be no minimum setback or other yard requirements other than those required through the Building Code and the Fire Code. However, the developer shall establish restrictions on yards on the final development plan.

23A-2(m) DENSITY CLUSTERING AND TRANSFERS - Shall be permitted as follows:

1. Density may be clustered on lands which are part of a single development plan under the same ownership and within the same zone and the same Expansion

Area so that the average density of the site does not exceed the maximum for the zoning category.

2. Density Transfer Rights may be transferred from any land which is designated as a Special Design Area, a Scenic Resource Area, a greenway or any land which contains environmentally sensitive land when the density allocated to that land by the underlying zoning district cannot be developed on site. Such density rights may be transferred to any parcel of land within the same Expansion Area which is designated as EAR-2, EAR-3, CC or TA and used in accordance with the density limitations of those districts.
 - a) Transfers of Fractions of DTR Prohibited - The transfer of less than one DTR or any other fraction of a unit shall not be permitted.
 - b) Use of Sender Site after Transfer - Once DTR have been severed from a Sender Site, the future use of the Sender Site shall be limited to the extent of the transfer, and a deed restriction in favor of the Lexington-Fayette Urban County Government shall be recorded restricting the use of the Site in accordance with procedures established by the Division of Planning.
 - c) Aggregation of DTR Permitted on Single Receiver Site - DTR may be aggregated from different Sender Sites for development on a single Receiver Site.
 - d) Receiver Site Must Meet Underlying Zone District Requirements - Development using DTR shall meet each and every requirement of the Zone District.
 - e) Density Rights Appurtenant to Land Until Development Plan Approval Obtained - The owner of DTR may transfer such rights at any time to any person; provided, however, that the use, rights and the value thereof shall be deemed for taxation and all other purposes to be appurtenant to the land from which the rights are transferred until a development plan is approved and certified, which authorizes the use of the transferred density.
 - f) Procedures - The use of DTR shall be carried out as follows:
 - 1) Application for Certificate of DTR and Approval of a Transfer - Prior to filing an application for development plan approval using DTR, the owner of a DTR shall obtain a Certificate of DTR from the Lexington-Fayette Urban County Government. In order to obtain a Certificate of DTR, the owner shall prepare an Affidavit of DTR and intent to transfer the DTR to a specific Receiver Site. Along with the Affidavit of DTR, the owner of a DTR shall attach a copy of the executed but unrecorded deed conveying the DTR and a copy of the executed but unrecorded deed restriction for the Sender Site. The affidavit shall be filed with the Division of Planning at least thirty (30) days prior to any application for development plan approval. The Division of Planning shall review the application and issue the Certificate of DTR if they determine that adequate documentation of ownership has been submitted and that the deed documents are recordable.
 - 2) Application for Development Plan Approval - An application for development plan approval utilizing DTR shall include the Certificate of DTR and shall demonstrate that the proposed development plan complies with the regulations applicable to the Receiver Site. The deeds of conveyance and restriction shall be recorded prior to certification of approval of the development plan.
 - 3) Where a developer dedicates land to a public entity, at no cost, for a purpose not expressly provided for through an exaction, and the public entity accepts such dedication, the developer may transfer the density allocated by the underlying zoning category of that parcel to any parcel of

land within the same Expansion Area which is designated as EAR-2, EAR-3, CC or TA.

23A-2(n) ACCESSORY DWELLING UNITS - Density, which might otherwise be implied by provisions which permit an Accessory Dwelling Unit, shall not be transferred to any other area or parcel of land.

23A-2(o) FENCING ALONG AGRICULTURAL LAND - Fencing shall be provided along the boundary of any development that adjoins land being used for agricultural purposes and which is recommended for Core Agricultural and Rural Land in the Comprehensive Plan. Such fencing shall be required to be a single standard gauge diamond mesh wire fence, of durable construction, not less than seventy-two (72) inches high set on 9-foot posts with a required 6-inch top board, unless the owner of the agricultural parcel agrees to an exemption, or to comparable protection, in the form of a legally recorded covenant.

23A-2(p) SATELLITE DISH ANTENNAS - Shall be permitted in all zones subject to the provisions of Article 15-7.

23A-2(q) FRONT YARD LANDSCAPING IN RESIDENTIAL ZONES - At least 50% of the front yard of any residential dwelling in any EAR category shall be landscaped with vegetative material of any type.

23A-2(r) BUFFERING OF USES - Buffering of uses shall be as follows:

1. Except as provided herein, where adjacent housing developments differ by more than three (3) dwelling units per acre, the Planning Commission may require a buffer yard of six (6) feet in width, with one tree for every 40' of linear boundary from the Group A, B, or C of the Plant List, as referenced by Article 18 of the Zoning Ordinance; plus a minimum 4-foot high hedge, fence, wall or earth mound or combination thereof. In order to encourage a diversity of housing types within a single development, such buffering shall not be required where single family detached houses are interspersed with or are adjacent to detached single family houses, duplexes, tri-plexes or four-plexes in a single development.
2. Any development in an ED or CC zone which directly adjoins any EAR zone shall be required to provide a buffer yard of six feet (6') in width, with one tree for every 30' of linear boundary from the Group A, B, or C of the Plant List, as referenced by Article 18 of the Zoning Ordinance; plus a 6-foot high fence, wall or earth mound. The responsibility for such buffer shall be the ED or CC property, although the buffer yard may be shared as provided in Article 18-3(a)(3)(c).
3. Any residential or non-residential development in the Expansion Areas which abuts an interstate highway shall meet the requirements of Article 18-3(a)(1)(4) as for a residential zone.

23A-2(s) SCENIC RESOURCE AREAS - Areas designated as Scenic Resource Areas shall be limited to a maximum on-site density of no more than three (3) dwelling units per five (5) acres. All development shall be clustered so that at least 80% of the portion of the development within the Scenic Resource Area is preserved as common open space or agricultural uses and is sited so as to minimize the visual impact of the development on the adjoining rural road to the greatest extent feasible. Within the Scenic Resource Areas, there shall be no parking areas and no buildings or structures other than driveways, transparent fences and stone fences permitted within 200 feet of the right-of-way of DeLong Road, Winchester Road, Walnut Grove Lane, Deer Haven Lane, Faulkner Avenue and Russell Cave Road. Utilities, drainage and sanitary sewer facilities may be located within this 200-foot area only upon the approval of the Planning Commission, who shall approve such facilities only upon a finding that alternative locations are not feasible from an engineering standpoint; would result in undue hardship; or would be detrimental from an environmental standpoint. Further, the Commission shall impose conditions on the design and installation of any facility to ensure that the visual quality of the area is maintained.

23A-2(t) SPECIAL DESIGN AREAS - All development in a Special Design Area shall be clustered so that at least 60% of the portion of the development within the Special Design Area is preserved as common open space or agricultural uses, and is sited so as to minimize the visual impact of the development on the adjoining rural road to the greatest extent feasible. Within the Special Design Areas, there shall be no parking areas and no buildings or structures other than driveways, transparent fences and stone fences permitted within 200 feet of the right-of-way of Delong Road, Athens-Boonesboro Road and Chiles- burg Road.

23A-2(u) BOUNDARIES OF SDAs - The boundaries of SDAs shall be as shown on the adopted Comprehensive Plan, unless it is determined during the development review process by the Planning Commission that the final boundary requires refinement based upon more detailed analysis of the final development features, such as roads; land use; topography; and view sheds. To further refine the boundary, the Planning Commission must find that the final development configuration will better implement the intent of the SDA than when the boundary was first established in the 1996 Comprehensive Plan. In all cases, the Planning Commission shall not reduce the overall land area in the SDA, nor modify the minimum setbacks from roadways established in 23A-2(t), and must adopt findings that the final boundary meets the intent of the Expansion Area Master Plan, and this Article of the Zoning Ordinance.

23A-2(v) PROTECTION OF WOODLANDS - The development of parcels of land which contain mature woodlands, tree stands, and/or significant individual trees which are identified in the Expansion Area Master Plan Natural Resources Map Series and/or Land Capability Study shall be designed and carried out so as to protect and preserve all mature trees to the maximum extent practicable. Individual trees may be removed only as necessary to carry out economically feasible development and/or to achieve the objectives of the Expansion Area Master Plan, provided that the removal of individual trees will not result in the loss of the woodlands or tree stands of which they are a part; and that the design of the development has maximized the preservation of tree stands and significant individual trees. Consideration should be given by the Planning Commission to alternative street cross-sections, street geometrics, and development designs where the developer has established that significant trees will be properly preserved as a result of such alternative designs and/or standards.

23A-2(w) AFFORDABLE HOUSING UNITS - Units that are designated as Affordable Housing Units shall be restricted by the developer exclusively to affordable housing for a minimum period of 15 years. Further, such units shall be identified separately in the Certificate of Land Use Restriction filed for the development where the units are located, and such units shall be subject to a deed restriction in favor of the Lexington-Fayette Urban County Government which shall restrict the use of the property and shall establish monitoring procedures to ensure that the units remain affordable during the period. During the affordability period, an affordable housing unit may be sold to a non-low-income household by acquisition of a DTR, which must be assigned to the site, and repayment of any and all development exactions that may have been waived. Such site may be a receiver of a DTR only if the maximum density permitted with DTR would not be exceeded.

23A-3 SCHEDULE OF ZONES - Sections 23A-4 through 23A-10 create the zoning categories for use within the Expansion Areas and establish the requirements and restrictions within each zone. The zones are as follows:

23A-4 CONSERVATION DISTRICT (CD) ZONE

23A-5 EXPANSION AREA RESIDENTIAL 1 (EAR-1) ZONE

23A-6 EXPANSION AREA RESIDENTIAL 2 (EAR-2) ZONE

23A-7 EXPANSION AREA RESIDENTIAL 3 (EAR-3) ZONE

23A-8 TRANSITION AREA (TA) ZONE

23A-9 COMMUNITY CENTER (CC) ZONE

23A-10 ECONOMIC DEVELOPMENT (ED) ZONE

The terms principal, accessory, conditional and prohibited, as applied to uses and structures within the Expansion Areas, shall have their usual and customary meaning as provided elsewhere within this Zoning Ordinance. Only those uses specifically named as principal, accessory or conditional uses or substantially similar to principal, accessory or conditional uses are permitted in each zone. All uses not specifically permitted or substantially similar to permitted uses are prohibited. Prohibited uses shall include, but not be limited to, those specifically named as prohibited.

23A-4 CONSERVATION DISTRICT (CD) ZONE

23A-4(a) INTENT - This zone is intended to provide areas within the Expansion Area for active and passive recreation and to provide neighborhood and community recreational facilities needed to serve the residents of the Expansion Area.

23A-4(b) PRINCIPAL USES

1. Outdoor commercial and noncommercial recreational facilities such as golf courses, driving ranges, zoological gardens, sportsmen's farms (excluding rifle and other firearm ranges), riding stables, fishing lakes, and outdoor swimming pools, outdoor tennis courts, outdoor skating rinks, baseball fields, soccer fields, polo fields, and the like; and including a structure not exceeding 1000 square feet for the administration of the outdoor recreational use.
2. Ecotourism activities to include hiking, bicycling, equine and zip line trails; tree canopy tours; canoeing and kayaking launch sites; botanical gardens and nature preserves.

23A-4(c) ACCESSORY USES

1. Private garages, storage sheds, and parking lots.

23A-4(d) CONDITIONAL USES

1. Sale of food and merchandise directly associated with the recreational activity when accessory to a principal use.
2. Lighting of outdoor recreational facilities.
3. Outdoor speakers and public address systems. Such systems shall only be permitted by the Board of Adjustment upon finding that the system would not constitute a public nuisance by creating excessive noise on the property and surrounding properties; and is a necessary adjunct to the proposed use and has been designed to serve only such need. The Board may limit such features as to the location, power, and time of operation of such systems to ensure the protection of surrounding uses and properties.
4. Temporary structures designed for use or occupancy for 61 to 180 days per 12-month period on a single property, calculating said period by cumulative consideration of the use of any and all such structures on a single property.
5. Ecotourism activities to include primitive camping, fishing and hunting clubs, and seasonal activities.

23A-4(e) PROHIBITED USES

1. Commercial recreational facilities such as amusement parks, bowling alleys, skating rinks, pool or billiard halls, outdoor theaters, automobile race tracks, athletic club facilities.
2. Indoor recreational facilities.
3. Ecotourism activities, except as permitted herein.

LOT, YARD AND HEIGHT REQUIREMENTS

23A-4(f) MAXIMUM HEIGHT OF A BUILDING - 35 feet.

23A-4(g) PARKING REQUIREMENTS

Outdoor Athletic Facilities - One space for every five spectator seats.

Riding Stables, Sportsmen's Farms, and Zoological Gardens - Five spaces plus one space for each employee.

Golf Courses - Three spaces for each hole on the main course.

Driving Ranges - One space per driving tee, plus one space per employee, with a minimum of five spaces.

Other Recreational Facilities or Ecotourism activities not otherwise stated herein – Five (5) spaces, plus, one (1) space for each employee for each separate use.

23A-5 EXPANSION AREA RESIDENTIAL 1 (EAR-1) ZONE

23A-5(a) INTENT - This zone is intended to provide a mixture of low density residential uses which will serve as a transition between the more intensely developed suburban neighborhoods and the Rural Service Area.

23A-5(b) PRINCIPAL USES

1. Single family, two-family, multi-family, and town- house dwellings.
2. Community Residences.
3. Golf Courses and common open spaces.
4. Places of religious assembly when located adjacent to a street that has the functional classification of collector/boulevard or arterial.

23A-5(c) ACCESSORY USES

1. Private garages and parking areas.
2. Accessory dwellings, as defined herein.
3. Swimming pools and tennis courts, which may include a clubhouse, as approved by the Planning Commission on a final development plan, for the use and enjoyment of the surrounding neighborhood, which may also include weight training and exercise rooms, restrooms, meeting rooms, or similar facilities.
4. Home offices and home occupations.
5. Family child care for up to six children.
6. The keeping of not more than two roomers or boarders by a resident family.
7. Child care facilities and schools for academic instruction when accessory to a place of religious assembly on the same property.
8. Non-commercial hiking and bicycling trails.

23A-5(d) CONDITIONAL USES

1. Home-based businesses.
2. Family Child care for seven and not more than 12 children, provided the total number of children living or being cared for on the premises shall not exceed twelve.

3. Temporary Real Estate Sales Offices for the sale of lots located only within the subdivision in which the sales office is located, to be removed at the end of two years or when all the lots are sold, whichever comes first.
4. Clubhouse, with sale of food and merchandise, when accessory to a golf course.
5. Historic house museums.
6. Schools for academic instruction, except as permitted herein, but only when located on a lot adjacent to a street that has the functional classification of collector/boulevard or arterial.
7. Equine trails.
8. Seasonal activities.
9. Market gardens.

23A-5(e) PROHIBITED USES - All uses not specifically listed as permitted shall be prohibited.

LOT, YARD, HEIGHT AND DENSITY REQUIREMENTS

23-A-5(f) DWELLING UNIT DENSITY – The dwelling unit density within the EAR-1 zone shall not exceed three (3) units per gross acre. (See Special Provisions below)

23A-5(g) MAXIMUM HEIGHT OF BUILDING – 35 FEET.

23a-5(H) FLOOR AREA RATIO – None; except where more than one principal residential structure is placed on a lot, the FAR shall not exceed 0.5.

23A-5(i) OFF-STREET PARKING REQUIREMENTS

1. There shall be a minimum of one space per dwelling unit for single family detached, duplex and townhouse residential units. Multi-family units shall have a minimum of 1.5 spaces per unit; except for elderly housing, which shall provide three (3) spaces for every four (4) units. One additional space shall be provided for any accessory dwelling unit.
2. Golf Courses – As per CD.
3. Community Residences - One space per every four (4) beds, plus one space for each employee on the maximum working shift, with a minimum of five (5) spaces.
4. Accessory and Conditional uses – Parking shall be as provided elsewhere in the Zoning Ordinance within the zone where the use is first permitted.

23A-5(j) SPECIAL PROVISIONS

1. At least twenty-five percent (25%) of the net developable acreage of any project in the EAR-1 zone shall be open space.

23A-6(A) EXPANSION AREA RESIDENTIAL 2 (EAR-2) ZONE

23A-6(a) INTENT - The intent of the Expansion Area Residential 2 Zone is to provide a mixture of residential uses and housing types, to allow density transfer from areas which should not be developed, and to provide for well-designed neighborhoods.

23A-6(b) PRINCIPAL USES

1. As for EAR-1.
2. Schools for academic instruction.

23A-6(c) ACCESSORY USES - As for EAR-1.

23A-6(d) CONDITIONAL USES

1. As for EAR-1.
2. Boarding houses, rehabilitation homes, nursing homes, personal care facilities, and assisted living facilities. As a prerequisite requirement, sites for such uses must front on a street with a functional classification of collector or arterial.
3. Existing radio, telephone or television transmitting or relay facilities as of May 26, 2005, including line-of-sight relays and towers, except as permitted by KRS 100.324, and only under the following conditions:
 - a. Such facilities shall be operated at all times in compliance with applicable Federal, State and local laws and regulations, including all standards of the Federal Aviation Administration and the Federal Communications Commission.
 - b. No transmitting or relay tower shall be located closer than the height of the tower from another lot under different ownership, or any public or private street or highway, unless the tower is constructed to withstand a minimum wind speed of one hundred (100) miles per hour.
 - c. The plans of tower construction shall be certified by an engineer registered in the Commonwealth of Kentucky.
 - d. All towers shall be equipped with an anti-climbing device or fence to prevent unauthorized access.

23A-6(e) PROHIBITED USES - As for EAR-1.

LOT, YARD, HEIGHT AND DENSITY REQUIREMENTS

23A-6(f) DWELLING UNIT DENSITY

Minimum Density - Three dwelling units per gross acre.

Maximum Density without DTR - Six dwelling units per gross acre.

Maximum Density with DTR - Nine dwelling units per gross acre.

23A-6(g) MAXIMUM HEIGHT OF BUILDING - 35 feet.

23A-6(h) FLOOR AREA RATIO - None; except where more than one principal residential structure is placed on a lot, the FAR shall not exceed 0.75

23A-6(i) MINIMUM FRONT YARD - 5 feet.

23A-6(j) OFF-STREET PARKING REQUIREMENTS -

There shall be a minimum of one space per dwelling unit for single family detached, duplex and townhouse residential units. Multi-family units shall have a minimum of 1.5 spaces per unit; except for elderly housing, which shall provide three (3) spaces for every four (4) units. One additional space shall be provided for any accessory dwelling unit.

23A-6(k) SPECIAL PROVISIONS

1. Affordable housing units shall not be considered as dwelling units for the purposes of calculating maximum density, provided the number of affordable units does not exceed eight (8) units per gross acre.
2. At least twenty-five percent (25%) of the net developable acreage of any project in the EAR-2 zone shall be open space.
3. Permitted schools shall not be located on a lot exceeding 15 acres in area.

23A-7 EXPANSION AREA RESIDENTIAL 3 (EAR-3) ZONE

23A-7(a) INTENT - The intent of the Expansion Area Residential 3 Zone is to provide a mixture of residential uses and housing types at a higher density than the other Expansion Area Residential zones, to allow density transfer from areas that should not be developed and to provide for well-designed neighborhoods.

23A-7(b) PRINCIPAL USES - As for EAR-2.

23A-7(c) ACCESSORY USES - As for EAR-2.

23A-7(d) CONDITIONAL USES - As for EAR-2.

23A-7(e) PROHIBITED USES - As for EAR-2.

LOT, YARD, HEIGHT AND DENSITY REQUIREMENTS

23A-7(f) DWELLING UNIT DENSITY

Minimum Density - Six dwelling units per gross acre.

Maximum Density without DTR - Eighteen dwelling units per gross acre.

Maximum Density with DTR - Twenty-four dwelling units per gross acre.

23A-7(g) MAXIMUM HEIGHT OF BUILDING - 60 feet.

23A-7(h) FLOOR AREA RATIO - None.

23A-7(i) MINIMUM FRONT YARD - 5 feet.

23A-7(j) OFF-STREET PARKING REQUIREMENTS - There shall be a minimum of one space per dwelling unit for single family detached, duplex and townhouse residential units. Multi-family units shall have a minimum of 1.5 spaces per unit, except for elderly housing which shall provide three (3) spaces for every four (4) units. One additional space shall be provided for any accessory dwelling unit.

23A-7(k) SPECIAL PROVISIONS

1. Affordable housing units shall not be considered as dwelling units for the purposes of calculating maximum density, provided the number of affordable units does not exceed eight (8) units per gross acre.
2. At least twenty-five percent (25%) of the net developable acreage of any project in the EAR-3 zone shall be open space.
3. Permitted schools shall not be located on a lot exceeding 15 acres in area.
4. No more than twenty-five percent (25%) of the required off-street parking for a multi-family residential development shall be located between the closest residential building and the right-of-way of any collector street.

23A-8 TRANSITION AREA (TA) ZONE

23A-8(a) INTENT - The intent of the Transition Area zone is to create an overlay district to be used in conjunction with an EAR zoning category to allow for the development of residential uses and civic, cultural, religious, and educational institutions on lands which are located immediately adjacent to Community Center zones.

23A-8(b) PRINCIPAL USES

1. As for the underlying EAR zoning category.

2. Only when the Transition Area is included as an integral part of the development plan for adjacent land in the Community Center zone, then the following uses shall be permitted:
 - a) Nursing homes and personal care facilities.
 - b) Kindergartens, nursery schools and child care centers for four (4) or more children. A fenced and screened play area shall be provided, which shall contain not less than twenty-five (25) square feet per child.
 - c) Places of religious assembly.
 - d) Buildings and facilities for social or recreational purposes operated by a non-profit organization and which are generally open to the public and do not render a service customarily carried on as a business.

23A-8(c) ACCESSORY USES - As for the underlying EAR zoning category.

23A-8(d) CONDITIONAL USES - As for the underlying EAR zoning category.

23A-8(e) PROHIBITED USES - As for the underlying EAR zoning category.

LOT, YARD, HEIGHT AND DENSITY REQUIREMENTS

23A-8(f) DWELLING UNIT DENSITY - As for the underlying EAR zoning category; except that when the property zoned TA is included as an integral part of the development plan for adjacent land in the Community Center zone, the density shall be as provided for the CC zone herein below.

23A-8(g) MAXIMUM HEIGHT OF BUILDING - As for the underlying EAR category; except that when the property zoned TA is included as an integral part of the development plan for adjacent land in the Community Center zone, the maximum permitted height shall be 48 feet.

23A-8(h) FLOOR AREA RATIO - As for the underlying EAR zoning category; except that when the property zoned TA is included as an integral part of the development plan for adjacent land in the Community Center zone, the FAR shall be as provided for the CC zone herein below.

23A-8(i) MINIMUM FRONT YARD - 5 feet

23A-8(j) OFF-STREET PARKING REQUIREMENTS

1. Residential Uses - As per the underlying EAR category.
2. Other Permitted Uses - Parking shall be as provided elsewhere in the Zoning Ordinance within the zone where the use is first permitted.

23A-8(k) SPECIAL PROVISIONS

1. As per the underlying EAR zoning category.

23A-9 COMMUNITY CENTER (CC) ZONE

23A-9(a) INTENT -The intent of this zone is to implement the Community Center land use designation in the Expansion Area Master Plan by providing a mixture of residential uses and non-residential uses which serve the needs of the surrounding residential neighborhoods.

23A-9(b) PRINCIPAL USES

1. As for EAR-3.

2. Banks, credit agencies, security and commodity brokers and exchanges, credit institutions, savings and loan companies, holding and investment companies.
3. Offices for business, professional, governmental, civic, social, fraternal, political, religious, and charitable organizations, including but not limited to, real estate sales offices.
4. Places of religious assembly.
5. Libraries, museums, art galleries, and reading rooms.
6. Medical and dental offices, clinics, and laboratories.
7. Studios for work or teaching of fine arts, such as photography; music; drama; dance and theater.
8. Community centers and private clubs.
9. Nursing and personal care facilities, and rehabilitation homes.
10. Computer and data processing centers.
11. Ticket and travel agencies.
12. Kindergartens, nursery schools and child care centers for four (4) or more children. A fenced and screened play area shall be provided, which shall contain not less than twenty-five (25) square feet per child.
13. Business colleges, technical or trade schools or institutions.
14. Establishments for the retail sale of food products, such as supermarkets; dairy, bakery, meat, beer, liquor, and wine and other food product stores; and provided that production of food products is permitted only for retail sale on the premises.
15. Restaurants, except as prohibited under Section 8-16(e)(14) and (15), which offer no live entertainment or dancing.
16. Establishments for the retail sale of merchandise, including clothing; shoes; fabrics; yard goods; fixtures, furnishings, and appliances, such as floor covering, radios, TV, phonograph products and other visual and sound reproduction or transmitting equipment; furniture; kitchen and laundry equipment; glassware and china; and other establishments for the retail sale of hardware and wallpaper, lawn care products; paint and other interior or exterior care products; hobby items; toys; gifts; antiques; newspapers and magazines, stationery and books; flowers; music; cameras; jewelry and luggage; business supplies and machines; prescription and non-prescription medicines and medical supplies.
17. Beauty shops, barber shops, shoe repair, self-service laundry, or laundry pick-up station, including clothes cleaning establishments of not more than 40 pounds capacity and using a closed system process.
18. Automobile service stations, provided such use conforms to all requirements of Article 16.
19. Repair of household appliances.
20. Retail sale of plant nursery or greenhouse products, except as prohibited herein.
21. Outdoor miniature golf or putting courses.

22. Quick copy services utilizing xerographic or similar processes, but not utilizing offset printing methods.
23. Carnivals, special events, festivals, and concerts on a temporary basis, and upon issuance of a permit by the Divisions of Planning and Building Inspection, which may restrict the permit in terms of time; parking; access; or in other ways to protect public health, safety, or welfare, or deny such if public health, safety, or welfare are adversely affected. A carnival, special events, festivals, and concerts may not displace more than twenty-five percent (25%) of the minimum required parking for the site it occupies.
24. Indoor theaters.
25. Rental of equipment whose retail sale would be permitted elsewhere in this zone.
26. Arcades, including pinball, and electronic games.
27. Athletic club facilities.
28. Swimming pools; tennis courts; putting greens; hiking, bicycling and equine trails; and other similar commercial and non-commercial recreational uses.
29. Brew-pub.
30. Day Shelters.
31. Commercial farm markets.
32. Market gardens.
33. Offices of veterinarians, animal hospitals or clinics, provided that (a) all exterior walls are completely soundproofed; (b) animal pens are located completely within the principal building; and (c) boarding is limited to only animals receiving medical treatment.

23A-9(c) ACCESSORY USES

1. As for EAR-3.
2. Storage, excluding outdoor storage, and provided that no building for such accessory use shall have openings other than stationary windows within one hundred feet (100') of any residential zone.
3. The sale of malt beverages, wine, or alcoholic beverages when accessory to a restaurant permitted under Section 8-16(b)(3). Such accessory use shall not devote more than twenty percent (20%) of its public floor area exclusively to the preparation and service of such beverages, nor provide any separate outside entrances or separate identification signs for those areas.
4. Parking lots and structures.
5. Satellite dish antennas as further regulated by Article 15-7.
6. One (1) or two (2) pool or billiard tables within an establishment.

23A-9(d) CONDITIONAL USES

1. As for EAR-3.
2. Drive-through facilities for the sale of goods or products or the provision of services otherwise permitted herein.
3. Mining of non-metallic minerals, but only when the proposal complies with the requirements of the Mining/Quarrying Ordinance (Code of Ordinances #252-91)

and the conditions and requirements as set forth therein. The Board of Adjustment shall specifically consider and be able to find:

- a) That the proposed use will not constitute a public nuisance by creating excessive noise, odor, traffic, dust, or damage to the environment or surrounding properties;
 - b) That a reasonable degree of reclamation and proper drainage control is feasible; and
 - c) That the owner and/or applicant has not had a permit revoked or bond or other security forfeited for failure to comply with any Federal, State or local laws, regulations or conditions, including land reclamation, pertaining to the proposed use.
4. Self-service car washes when accessory to a service station, provided that surface water from such establishments shall not drain onto adjacent property, and that adequate on-site storage lanes and parking facilities shall be provided so that no public way shall be used for such purposes.
 5. A restaurant, without live entertainment or dancing, which devotes more than twenty percent (20%) of its public floor area exclusively to the preparation and service of malt beverages, wine or alcoholic beverages.
 6. Restaurants offering live entertainment and/or dancing, cocktail lounges, or nightclubs [unless prohibited under Section 8-14(e)(14) and (15)]. Such uses shall be located at least 100 feet from any residential zone and shall be soundproofed to the maximum extent feasible by using existing technology, with noise emissions not creating a nuisance to the surrounding neighborhood.
 7. Upholstery shop.
 8. Outdoor speakers and public address systems. Such systems shall only be permitted by the Board of Adjustment upon findings that the system would not constitute a public nuisance by creating excessive noise on the property and surrounding properties; and is a necessary adjunct to the proposed use and has been designed to serve only such need. The Board may limit such features as the location, power, and time of operation of such systems to ensure the protection of surrounding uses and properties.
 9. Gasoline pumps available to the public without an employee on site, provided a plan is approved by the Board of Adjustment for periodic inspection of the site by an employee for the following purposes:
 - a. To check on all operating equipment;
 - b. To check fire suppression system(s);
 - c. To check the condition of the fire alarm(s);
 - d. To check for indications of fuel leaks and spillage;
 - e. To remove trash from the site;
 - f. To monitor the general condition of the site.
 10. Temporary structures designed for use or occupancy for 61 to 180 days per 12-month period on a single property, calculating said period by cumulative consideration of the use of any and all such structures on a single property.
 11. Circuses, provided all structures are located not less than two hundred (200) feet from any residential zone; and further provided that all structures for housing animals shall be two hundred (200) feet from any residential zone, residential use, school, hospital, nursing home or personal care facility. A circus may not displace more than twenty-five percent (25%) of the minimum required parking for the site it occupies.

12. Ecotourism activities to include zip line trails; tree canopy tours; fishing clubs; botanical gardens; natural preserves; and seasonal activities.
13. Recreation vehicle and trailer campgrounds, but only when located within 500 feet of an interstate interchange.
14. Hunting clubs, but only when located more than 500 feet from a residential zone.

23A-9(e) PROHIBITED USES

1. As for EAR-3.
2. As for A-R, except as expressly permitted herein.
3. Any use dependent upon septic tanks or pit privies.
4. Pawn shops.
5. Golf driving ranges.
6. Except when accessory to a permitted automobile service station, the above- or below-ground storage of any flammable material in gaseous form, including compressed natural gas; and the above- or below-ground storage of more than five (5) gallons of gasoline.
7. Greenhouses, plant nurseries, and garden centers.
8. Establishments primarily engaged in agricultural sales and services.
9. Warehouses, as well as storage uses, except as accessory uses herein.
10. Shops of special trade and general contractors, such as plumbing; heating; carpentry; masonry; plastering; painting; metal work; printing; electrical; sign painting; tile, mosaic and terrazzo work; electro-plating; drilling; excavating; wrecking; construction, and paving. This is not intended to prohibit the administrative offices of such.
11. Manufacturing, compounding, assembling, bottling, processing and packaging and other industrial uses for sale or distribution other than as retail on the premises.
12. Truck terminals and freight yards.
13. Amusement enterprises, such as outdoor theaters, automobile racing, horse racing.
14. Kennels, outdoor runways or pens for animals.
15. Establishments engaged in the display, rental, sales, service and major repair of automobiles, repair of motorcycles, boats, trucks, travel trailers, farm implements, contractor's equipment, mobile homes, and establishments primarily engaged in the sale of supplies and parts for any of the above-mentioned vehicles or equipment, except as permitted herein.
16. Establishments for cleaning, dyeing, laundering and the like, other than self-service and pick-up stations; except for clothes cleaning establishments of not more than forty (40) pounds capacity and using a closed system process.
17. Hotel or motel.
18. Wholesale establishments.
19. Greenhouses, nurseries, hatcheries.
20. Establishments offering live entertainment in which a person simulates any sexual act or in which a person is unclothed, or in such attire, costume, or clothing as to expose to view any portion of the female breast below the top of the areola, the male or female genitalia, or the buttocks.

21. Establishments at which any employee is unclothed or in the attire, costume or clothing described above, or is clothed in such a manner as to simulate the breast, genitalia, buttocks, or any portion thereof.
22. Establishments having as a substantial or significant portion of their stock in trade for sale, rent or display, pictures, books, periodicals, magazines, appliances and similar material which are distinguished or characterized by their emphasis on matter depicting, describing or relating to such sexual activities as (a) depiction of human genitals in a state of sexual stimulation or arousal; (b) acts of human masturbation, sexual intercourse or sodomy, or (c) holding or other erotic touching of human genitals, pubic region, buttocks or breasts.
23. Indoor motion picture theaters having as a substantial or significant portion of their use the presentation of material having as a dominant theme or characterized or distinguished by an emphasis on matter depicting, describing or relating to such sexual activities as (a) depiction of human genitals in a state of sexual stimulation or arousal; (b) acts of human masturbation, sexual intercourse or sodomy; or (c) holding or other erotic touching of human genitals, pubic region, buttocks or breasts.
24. Pool or billiard halls.
25. Primitive campgrounds; farm tours; hayrides; corn mazes; outdoor rodeos; riding stables; horse shows; fishing lakes; hunting and trapping; sportsmen's farms; and zoological gardens.

LOT, YARD, HEIGHT AND DENSITY REQUIREMENTS

23A-9(f) DWELLING UNIT DENSITY - No limitation (See Special Provisions below).

23A-9(g) MAXIMUM HEIGHT OF BUILDING - 48 feet.

23A-9(h) FLOOR AREA RATIO - A maximum of 1.0; however, the FAR may be increased to 1.5, provided that the FAR in excess of 1.0 is used for affordable housing.

23A-9(i) MINIMUM FRONT YARD - 5 feet.

23A-9(j) OFF-STREET PARKING REQUIREMENTS

1. Residential Uses - As per EAR-3.
2. All other uses - Parking shall be as provided else- where in the Zoning Ordinance within the zone where the use is first permitted.

23A-9(k) SPECIAL PROVISIONS

1. At least 25% of the net developable acreage of any development within a CC zone shall be open space.
2. At least 40% of the aggregated floor area of buildings within a development in a CC zone shall be devoted to residential uses as permitted in EAR-3; schools, places of religious assembly and their accessory structures; and public buildings.
3. No building shall exceed 20,000 square feet in floor area, except:
 - a. a building that contains a mix of residential and non-residential uses; or
 - b. a building designed and intended to be used for a school, **place of religious** assembly or public building;
 - c. a building is designed and intended to be used principally as a store selling food, produce and other grocery items (not primarily general merchandise) and not exceeding 80,000 square feet; and

- d. up to two additional buildings, which are designed and intended to be used primarily as stores selling general merchandise, which may include food, produce and other grocery items; but only under the following conditions:
 1. the proposed building shall be located within a CC zone containing at least 30 net contiguous acres, and that has frontage on an interstate interchange;
 2. the building shall be part of an integrated development governed for all contiguously zoned CC land (excluding right-of-way) by a single development plan; and
 3. any building exceeding 80,000 square feet in size shall also adhere to the "Design Guidelines for 'Big-Box' Establishments," excluding guideline numbers 6 and 14, which are contrary to other provisions of the CC zone. Such design guidelines shall be met unless waived by the Planning Commission through its approval of a final development plan.
- e. the maximum number of buildings permitted over 20,000 square feet by subsections c & d (above) shall be two.
4. Parking areas shall be designed so as to minimize the placement of parking between the buildings and the adjoining streets.
5. Each development within a CC zone shall have access to a pedestrian accessway.
6. Each development shall provide suitable facilities for the parking of bicycles.
7. The development shall be screened from adjoining zones as for a business zone under Article 18-3(a)(1).
8. Structures shall be sited to avoid the rear of the building facing a street (other than an alley) to the greatest extent practicable.

ARTICLE 23A-10 ECONOMIC DEVELOPMENT (ED) ZONE

Article 23A-10 (as recommended by the Planning Commission)

23A-10(a) INTENT - The purpose of the Economic Development zone is to provide land within the Expansion Area for employment opportunities compatible with the overall character of development as provided in the Expansion Area Master Plan.

23A-10(b) PRINCIPAL USES

1. Offices for business, professional, governmental, civic, social, fraternal, political, religious and charitable organizations.
2. Computer and data processing centers.
3. Medical and dental offices, clinics and laboratories, and hospices.
4. Research development and testing laboratories or centers.
5. Mail order businesses.
6. The manufacturing, compounding, assembling, processing, packaging, or similar treatment of articles of merchandise from the following previously prepared materials: asbestos, bone, canvas, cellophane, cellulose, cloth, cork, feather, felt, fiber, fur, glass, hair, horn, leather, paper, plastics, precious and semi-precious metals, precious and semi-precious stones, rubber, sheet metal (excluding large stampings), shell, textiles, tobacco, wax, wire, wood (excluding sawmills, planing mills), and yarn.
7. The manufacturing, compounding, assembling, processing, packaging, or similar treatment of such products as: bakery goods; billboards; candy; ceramics; cosmetics; drafting instruments; electrical parts; appliances; electric or neon

signs; electronic instruments; food products; meat packaging; ice cream; medical and dental instruments; musical instruments; pharmaceuticals; pottery, china, or figurines; radios; record players; rubber and metal stamps; rubber products; scientific instruments and equipment; shoes; television receivers; toiletries, soaps and detergents; toys; and watches and clocks.

8. Other industrial and manufacturing uses such as auto parts rebuilding; battery manufacturing; beverage manufacturing; dairy and non-dairy and food and non-food product bottling plants; box and crate assembly; building materials sales; rental storage yard; bag, carpet and rug cleaning and dyeing; cabinet shop; cannery; caterers; cooperage; crematory; dextrine and starch manufacturing; enameling, lacquering, and japanning; felt manufacturing; electric foundry; furniture manufacturing; heating equipment manufacturing; inflammable underground liquid storage; iron works (ornamental) and wire drawing; parcel delivery stations; phonograph record manufacturing; public utility service yard; radium extraction; stone monument works; tool manufacturing, welding, and other metal working shops.
9. Regional medical campus consisting of an integrated complex of medical service providers and related support facilities on a campus of not less than fifty (50) gross acres governed by a single development plan. The development plan must demonstrate that the regional medical campus will contain hospitals and similar in-patient treatment facilities, which may include accessory cafeterias, pharmacies and gift shops. In addition, the following uses shall be considered part of a regional medical campus: outpatient clinics and treatment facilities, surgery centers, nursing homes, medically-supervised assisted living facilities, and extended-stay hotels.
10. Colleges, universities, business colleges, technical or trade schools, and other schools and institutions for academic instruction.
11. Offices of purchasers, processors, and handlers of agricultural products, limited to administrative uses only.

23A-10(c) ACCESSORY USES

1. Off-street parking areas and structures, and loading facilities.
2. A dwelling unit for watchmen or caretakers, provided that such facilities shall be located on the same premises as the permitted use.
3. Facilities for serving food only for employees and visitors, having no direct access to the exterior and having no signs visible from the exterior of the building.
4. Offices.
5. Recreational facilities, except as otherwise permitted herein.
6. Sale of finished products related or incidental to the principal use, provided that the area set aside for sales of these related or incidental items does not constitute more than five percent (5%) of the total floor and storage area.
7. Storage and warehousing.
8. Libraries, museums and reading rooms.
9. Meeting and conference centers.
10. Establishments limited to the filling of prescriptions and retail sale of pharmaceutical and medical supplies with a drive-through window, provided it meets the following conditions:
 - a) Establishments limited to the filling of prescriptions shall be located in a building, the primary use of which is for medical uses; including, but not limited to, hospitals; in-patient treatment facilities; hospices; outpatient facilities; surgery centers; medical and dental offices, clinics or laboratories.

- b) Establishments principally used for the retail sale of pharmaceutical and medical supplies shall be internally oriented to the site (e.g., not located on adjoining arterial streets).
 - c) It shall have no more than one public entrance and one service entrance directly to the outside of the building.
 - d) Signage for such establishments may be directly, indirectly or internally illuminated; there shall be no more than one (1) wall-mounted business sign per such establishment, not to exceed thirty-two (32) square feet in area; and no more than one (1) free standing monument type business sign, eight (8) feet in height, with a maximum size of thirty-two (32) square feet.
11. Satellite dish antennas, as further regulated by Article 15-8. When located within 200 feet of the Urban Service Area boundary, satellite dish antennas shall be limited to:
- a) A maximum height of four (4) feet above the highest point of the principal building on the lot.
 - b) If located on the ground, satellite dish antennas shall not be visible from the road, and shall be screened with landscape material.
12. Restaurants, provided they meet the following conditions:
- a) It shall be located in an office building or extended-stay hotel containing a minimum of 40,000 square feet of floor area.
 - b) It shall occupy not more than twenty-five percent (25%) of the building in which it is located.
 - c) It shall have no more than one public entrance and one service entrance directly to the outside of the building, and this use shall be at least one hundred fifty (150) feet from any residential zone.
 - d) It shall have no drive-in or drive-through food service.
 - e) There shall be no more than two restaurants within an office building or extended-stay hotel, provided that the 25% limitation is not exceeded.
 - f) Signs permitted per office building may be used to identify the restaurant and/or the office use.
13. For premises not permitted under 23-A(1)(c)(12) above, facilities for serving food only for employees and visitors; having no direct access to the exterior, and having no signs visible from the exterior of the building. Mobile food unit vendors may also serve this purpose, and be parked outside of a building to serve employees and visitors, provided that the requirements of Section 15-11 of the Code of Ordinances are met.

23A-10(d) CONDITIONAL USES

1. Kindergartens, nursery schools and child care centers, where enrollment of children is sponsored and licensed by established places of religious assembly and non-profit community based groups; and/or where enrollment may be limited to children of employees and staff of an office, business or commercial establishment that is located within the contiguous ED zone as the proposed child care facility. A fenced and screened play area shall be provided in an area located a minimum of ten (10) feet from a collector or arterial street, and shall contain not less than twenty-five (25) square feet per child.
2. Helistops and heliports, provided such facilities conform to the requirements of all appropriate federal, state and local regulations.
3. Mining of non-metallic minerals, but only when the proposal complies with the requirements of the Mining/Quarrying Ordinance (Code of Ordinances #252-91)

and the conditions and requirements as set forth therein. The Board of Adjustment shall specifically consider and be able to find:

- a) That the proposed use will not constitute a public nuisance by creating excessive noise, odor, traffic, dust, or damage to the environment or surrounding properties;
 - b) That a reasonable degree of reclamation and proper drainage control is feasible; and
 - c) That the owner and/or applicant has not had a permit revoked or bond or other security forfeited for failure to comply with any Federal, State or local laws, regulations or conditions, including land reclamation, pertaining to the proposed use.
4. Temporary structures designed for use or occupancy for 61 to 180 days per 12-month period on a single property, calculating said period by cumulative consideration of the use of any and all such structures on a single property.
 5. Ecotourism activities to include campgrounds; commercial hiking and bicycling trails; equine and zip line trails; tree canopy tours; canoeing and kayaking launch sites; recreational outfitters; fishing and hunting clubs; botanical gardens; nature preserves; and seasonal activities.
 6. Market gardens.

23A-10(e) PROHIBITED USES

1. All uses listed as permitted or prohibited within the B-4, I-1 and I-2 zones, except as expressly permitted herein.
2. Radio, telephone or television transmitting or relay facilities, including line-of-sight relays and towers.
3. Dormitories.

LOT, YARD, HEIGHT AND DENSITY REQUIREMENTS

23A-10(f) MAXIMUM HEIGHT OF BUILDING - 90 feet, exclusive of mechanical equipment; or a 1:2 height-to-yard ratio, whichever is less, as measured from the contiguous ED zone boundary, provided that the average height of all buildings within the contiguous ED zone shall not exceed 48 feet.

23A-10(g) FLOOR AREA RATIO - A maximum of 0.75.

23A-10(h) MINIMUM FRONT YARD - 5 feet.

23A-10(i) OFF-STREET PARKING REQUIREMENTS - Parking shall be as provided elsewhere in the Zoning Ordinance within the zone where the use is first permitted.

Hospices – One (1) space for every two (2) beds; plus one (1) space for each employee on the maximum working shift, with a minimum of five (5) spaces.

23A-10(j) SPECIAL PROVISIONS

1. At least 25% of the net developable acreage of any development within an ED zone shall be open space.
2. No structures other than sidewalks, transparent fences, or stone fences shall be located within 5' of any public street right-of-way.
3. No more than half of the required off-street parking area shall be located between a building and any collector street.
4. Each parcel in an ED zone shall have direct access to a pedestrian accessway,
5. The development shall be screened from adjoining zones and arterial highways as for an industrial zone under Article 18-3(a)(l).
6. All uses shall be conducted in a completely enclosed building, except for outdoor storage uses, which shall be enclosed on all sides by a solid wall or fence not less than six feet (61) in height.

7. All buildings and structures shall be at least one hundred (100) feet from any residential zone, unless the portion within that distance has no openings except stationary windows and doors that are designed and intended solely for pedestrian access.
8. No build buildings or structures in the ED zone, other than driveways, transparent fences and stone fences, shall be located in a Scenic Resource Area; however, the Scenic Resource Area may be used to calculate the required floor area ratio.
9. No outdoor loud speakers shall be permitted.
10. No portion of a regional medical campus shall be located within 1,000 feet of the boundary of the Urban Service Area.
11. There shall be no more than one extended-stay hotel for a regional medical campus that contains more than 100 acres or less; provided that there shall be no more than two (2) extended-stay hotels in a regional medical campus. The extended-stay hotel shall be: a) a part of a building that also contains medical facilities permitted on the campus; or b) physically connected by interior access ways to facilities containing medical services permitted on the campus. Extended-stay hotels shall be internally oriented to the site (e.g., not located on adjoining arterial streets).

APPENDIX 23B - EXPANSION AREAS PROCEDURES AND REQUIREMENTS

23B-1 PURPOSE - The purpose of this appendix is to create and define procedures and requirements for approval of development within the Expansion Areas of the Lexington-Fayette County Urban Service Area.

23B-2 PRELIMINARY AND FINAL DEVELOPMENT PLAN REQUIRED - A preliminary development plan shall be required as specified in Article 21-3 in conjunction with any zone map amendment request in the Expansion Area. The standards and procedures specified in Articles 21-4, 21-5 and 21-6 shall be applicable. No development activity, building, or occupancy of property shall be permitted unless and until a final development plan has been approved by the Planning Commission. The development plan shall limit and control the issuance of all building and occupancy permits, and shall restrict the construction, location, and use of all land to the conditions as set forth in the plan.

23B-3 INTERIM AGRICULTURAL USES EXCEPTED - The only exception from the provisions of 23B-2 above shall be the principal permitted uses as set forth for the A-R zone in Article 8-1. Such uses, including the construction of one principal single family dwelling, shall be permitted by right, subject to the typical requirements of law contained in this Zoning Ordinance or other applicable ordinances for such construction, such as building permits, land disturbance permits, and the like.

23B-4 CONTENT AND FORMAT FOR FINAL DEVELOPMENT PLANS WITHIN THE EXPANSION AREAS - Final development plans required pursuant to this Article shall meet, at a minimum, all information as required for a final development plan as set forth under Article 21-6. In addition, the following shall be a required part of the final development plan and shall be submitted at the time of the application:

23B-4(a) COMPREHENSIVE PLAN COMPLIANCE STATEMENT - This document shall set forth the developer's specific actions related to natural environment, land use, open space, housing, community design, public facilities, design features and criteria, density, and similar matters to demonstrate that the final development plan complies with the "Future Land Use" and "Community Design" Elements of the adopted Expansion Area Master Plan.

23B-4(b) INFRASTRUCTURE STATEMENT - This document shall set forth a project description including engineering and construction cost estimates prepared by a professional engineer for the public and/or private expenditures for system improvements that the developer proposes to construct, and for construction, or other development activity which will be in place prior to or in conjunction with the development. This document will demonstrate that the proposal complies with the

“Infrastructure Element” of the adopted Expansion Area Master Plan. Any proposed or executed development agreement that is required or anticipated by the developer as set forth under 23C-7 herein below shall also be a part of this statement. At the time of the application, the developer shall distribute copies of the Infrastructure Statement to the Chief Administrative Officer, the Commissioner of Public Works, the Commissioner of Finance, and the Commissioner of General Services. Such officials shall review the proposed statement and provide their comments to the Division of Planning prior to Planning Commission action.

23B-4(c) OTHER INFORMATION ON THE FINAL PLAN - The final development plan shall indicate the developer’s restrictions for lot sizes (minimum and, where appropriate, maximum); yard and setback restrictions; coverage restrictions; height limitations; floor area ratios; project lighting; or similar restrictive techniques to be established within the development or defined areas within it so as to achieve the purposes of the Expansion Area Master Plan and to prevent or minimize potential adverse effects upon properties within and in the vicinity of the proposed development.

23B-4(d) DTR RELATED INFORMATION - For any final development plan which proposes units permitted under a DTR, a copy of the Certificate of DTR shall be filed as a part of the application.

23B-5 REVIEW PROCEDURES - Final development plans required under this Article shall follow the development plan procedures as set forth in Article 21-4, except as specifically modified herein.

23B-5(a) STAFF REPORT ON COMPLIANCE WITH EXPANSION AREA MASTER PLAN AND INFRA- STRUCTURE - In addition to all other reports and recommendations from staff and review committees provided to the Commission, the Division of Planning shall prepare and submit for Commission review a report reviewing the final development plan’s compliance with the Expansion Area Master Plan. The report shall review the statements and information provided by the developer under 23B-4(a) through (d) above, and may make specific recommendations on design changes needed to establish compliance with the Expansion Area Master Plan. The Division shall include comments from all applicable Departments involved with public facilities within the development, including the physical extent of the proposed project improvements; exactions; related capital improvements financing; regulations; and similar matters.

23B-5(b) COMMISSION HEARING AND ACTION - The Planning Commission shall advertise and conduct at least one public hearing and shall approve, conditionally approve with conditions noted, or disapprove any request for action on a final development plan within 120 days of its filing unless the applicant agrees to an extension of time beyond such period. The minimum notice shall include a newspaper notice placed not more than 21 days, nor less than 7 days, in advance of the hearing; and the posting by the applicant of a sign in a conspicuous location on the property. The sign shall be constructed of durable material; shall not be less than four (4) feet by four (4) feet; shall state “development plan” in bold letters not less than three (3) inches in height; shall state the time, date, and location of the hearing and the phone number of the Division of Planning in letters at least one (1) inch in height; and shall be posted on the property at a location which is visible from the highest traffic volume roadway abutting the property not more than 14 days after the filing of the plan and maintained until the hearing date. The applicant shall provide an affidavit to the Planning Commission at the hearing, stating that the sign was posted as required and has been maintained on the property during the notice period to the best of the applicant’s knowledge and ability.

23B-5(c) COMMISSION ACTION - No development plan shall be considered for action by the Commission until it has been reviewed by, and recommendations made by, the Subdivision Committee unless this requirement is waived by the Commission under its adopted late filing procedures. The Commission will review all staff and committee recommendations, comments made in the public hearing, and shall then act for approval, conditional approval with conditions noted, postponement, or dis-

approval. The Commission may modify through conditional approval or disapprove the development plan if it finds the plan does not comply with the requirements of the Zoning Ordinance, and when applicable, the Land Subdivision Regulations; or if it finds there are existing or potential flood, drainage, traffic, topographic, health, safety, nuisance or other similar problems relating to the development of the subject property which cannot be properly mitigated.

Further, approval of the development plan will require a finding on the part of the Planning Commission that the plan is in compliance with the Infrastructure, Future Land Use, and Community Design Elements of the Expansion Area Master Plan, and the Commission may disapprove or require modifications to the development plan to ensure such compliance, and the need to prevent or minimize adverse effects upon properties within or in the vicinity of the development. The Commission shall impose conditions regarding construction of required infrastructure and the proposed development to ensure that development is supported by infrastructure consistent with the Expansion Area Master Plan and any development agreement. The Commission shall permit the construction and bonding of required infrastructure pursuant to the provisions of Section 4-7 of the Land Subdivision Regulations.

In addition to these items, development plans which seek to amend the original development plan or its approved amendments shall also be subject to the provisions of Article 21-7(e). Reasons for action of postponement or disapproval shall be fully incorporated in the Commission's minutes. The following actions by the Commission shall have the meanings so stated:

(1) APPROVAL - Means the development plan is ready to be certified by the Commission's Secretary with no further corrections or revisions of the plan required by the developer.

(2) CONDITIONAL APPROVAL - Means the development plan cannot be certified by the Commission's Secretary until the developer has complied with the conditions of approval set forth in the Planning Commission's action on the plan.

(3) POSTPONEMENT - Means that the Commission has deferred action until some future Commission meeting in order that certain clarifications can be made in regard to the development plan. No completely new re-submittal is required of the developer as is the case for disapproval.

(4) DISAPPROVAL - Means disapproval of the plan. To request new review and action, the developer must file a new application along with a filing fee, plan copies, and other material as required herein. For any action of disapproval, the Planning Commission shall be required to make specific findings to support such action.

23B-5(d) CERTIFICATION OF APPROVAL - Within one (1) year of the Commission's approval, unless a time extension has been granted previous to the expiration date, the following steps shall be completed, or else the Commission's approval becomes null and void:

- (1) The developer shall fully comply with any conditions of approval placed on the plan by the Commission and submit the completed original tracing of the plan, including the signed owners' certification, to the Division of Planning;
- (2) The plan shall be certified by the Commission's Secretary if it is in conformance with all requirements, Required copies of the certified plan shall be made by the Division of Planning at the developer's expense.

In conjunction with any request by the developer for a time extension or re-approval of an expired plan, the Commission may require changes in the development plan when it finds that time has necessitated such changes for the health, safety and welfare of the residents of the community, or when applicable ordinances and regulations have been changed.

23-B-6 SUBDIVISION OF LAND - The following provisions shall apply to subdivision of land within the Expansion Area.

23B-6(a) APPLICABILITY TO SUBDIVISIONS - Except as expressly specified in this Article, all subdivision of land within the Expansion Area shall be required to comply with all procedures, requirements and standards of the Land Subdivision Regulations for major or minor subdivisions as applicable to the nature of the proposed subdivision.

23B-6(b) APPLICABILITY TO DEVELOPMENT PLANS - Where any development plan under this Article indicates a need or intent to subdivide property, all design and improvement standards contained in the Land Subdivision Regulations shall be applicable to the development plan.

23B-6(c) DEVELOPMENT PLAN AND PRELIMINARY SUBDIVISION PLAN MAY BE COMBINED - The required development plan and preliminary subdivision plan may be combined as set forth in Article 21-8(c).

23B-7 AMENDMENTS - Amendments to development plans under this Article shall be as provided in Article 21-7 of the Zoning Ordinance, except as modified herein above.

APPENDIX 23C - EXPANSION AREAS DEVELOPMENT EXACTION

23C-1 INTENT - This Article is intended to implement and facilitate orderly growth consistent with the Expansion Area Master Plan element of the 1996 Lexington-Fayette Urban County Comprehensive Plan by assuring that new development activity is served by adequate public facilities and bears a proportionate share of the cost of improvements necessary to provide roads, parks, open space and sanitary sewer treatment, sanitary sewer transmission capacity and storm water management facilities in the Expansion Areas of Lexington-Fayette County; and to mitigate the loss of rural landscape in the Expansion Areas by providing for an exaction for preservation of undeveloped land within the Rural Service Area in the vicinity of the Expansion Areas or of community-wide significance. The provisions of this Article are intended to implement the infrastructure financing concepts contained in the Expansion Area Master Plan in a manner consistent with the laws of the Commonwealth of Kentucky. The Expansion Area Master Plan financing concepts included allocation of certain exactions at 50% to be paid prior to building permit, with the remaining 50% to be obtained from ultimate users of the property. The provisions of Section 23C-6(b) are designed to address this concept by providing mechanisms which allow for the direct or indirect recovery of exactions paid by builders/developers from such ultimate users.

23C-2 DEFINITIONS - The terms as defined herein shall apply to all of Article 23.

BUILDING PERMIT - A document issued by the Lexington-Fayette Urban County Government, pursuant to its zoning regulations, authorizing the construction, repair, alteration or addition to a structure; or authorizing the placement or relocation of a mobile home.

CAPITAL IMPROVEMENTS - Those capital improvements necessary to support new development activity and which are identified in that portion of the Lexington-Fayette Urban County Expansion Area Master Plan as public facilities which are to be financed by the imposition of an exaction.

CAPITAL IMPROVEMENT PLAN - A plan reviewed and updated annually by the Lexington-Fayette Urban County Government, which in addition to other facilities, designates the size, extent, location, need and estimated cost of public facilities to serve the need created by new development activities.

DEVELOPER - Any person who engages in development activity.

DEVELOPMENT ACTIVITY - Any construction, modification or expansion of a building, structure or use that will generate additional impact or demand on the Urban County Government's public facilities for which an exaction is imposed pursuant to this Article, which is governed by the Lexington-Fayette Urban County Zoning Ordinance and/or the Lexington-Fayette Urban County Land Subdivision Regulations.

ENCUMBER - To legally obligate by contract or otherwise commit to use by appropriation or other official act of the Lexington-Fayette Urban County Government.

EXACTION - A fee or a land dedication in lieu of a fee required pursuant to this Article, and calculated based upon the cost of capital improvements in reasonable relationship and in a proportionate share to new development activities creating the need for such capital improvements.

EXACTION CREDIT - An obligation owed by the Lexington-Fayette Urban County Government to a developer for construction of system improvements.

EXACTION CREDIT, APPLICATION OF - The act of redeeming an approved exaction credit for the payment of exactions due under this Article, and in a manner permitted under this Article.

EXACTION CREDIT, CLAIMED - The written declaration by a developer of the construction (or proposed construction) of a system improvement eligible for an exaction credit.

EXACTION CREDIT CERTIFICATES - Instruments issued to the developer by the Lexington-Fayette Urban County Government, payable only from the exaction fund in amounts equal to the actual cost of system improvements constructed by the developer, or contributions or dedication of land by the developer, which exceeds the other exactions due with respect to the developer's property. These certificates shall be used only for the payment of exactions as provided herein; or may be surrendered for payment from the Exaction Fund in an order based upon the date of surrender. Exaction credit certificates are for the expressed purpose of reimbursing a developer for credits due for system improvements; and unless otherwise specified under a development agreement, shall not accrue interest or any other increase in value over the face amount stated in the certificate.

EXACTION DISTRICT - A geographic area identified by the Expansion Area Master Plan in which a defined set of public facilities is required to provide service to new growth and development. Any road right-of-way used to define exaction district boundaries may be considered to be within any exaction district it bounds for the purpose of using the funds collected pursuant to this Article.

EXACTION FUND - A separate fund established by the Lexington-Fayette Urban County Government exclusively to hold or pay out exactions.

EXPANSION - Means the expansion of the capacity of a public facility, and applies to all modifications designed to accommodate increased capacity, or to any capacity enhancements made reasonably necessary by new development activities.

FEEPAYOR - That person who pays an exaction, or his successor in interest.

OPEN SPACE - As used for exaction purposes only, this term is applied to undeveloped land within the Rural Service Area to be acquired or otherwise preserved in its undeveloped state and which may be used only for purposes which include recreation, agriculture, or aesthetic preservation.

PARK - A system improvement which consists of land identified in the Expansion Area Master Plan intended for acquisition by the Lexington-Fayette Urban County Government for use as a public park, or any land acquired by the Lexington-Fayette Urban County government for such purpose. For the purposes of this Article, the term "park," and the exactions attendant thereto, shall also include lands which meet all of the following criteria: 1) the land is designated as a greenway in the Expansion Area Master Plan, or has been designated as a greenway by the Planning Commission on an approved development plan; 2) the land lies outside of the post-development floodplain; and 3) the land lies outside of an area measured 100 feet in both directions from the center of the greenway.

PERSON - An individual, a corporation, a partnership, an incorporated association, or any other similar entity.

PROJECT IMPROVEMENTS - Site improvements and facilities that are planned and designed to provide service for a particular development which are not system improvements and which are necessary solely for the use and convenience for the occupants or users of the project.

PROPORTIONATE SHARE - That portion of the cost of system improvements which is reasonably related to the demands and needs of a project.

PUBLIC FACILITY - Those facilities identified in the Expansion Area Master Plan for which exactions are imposed to pay the cost of capital improvements and include road improvements, open space acquisition, park acquisition, storm water management facilities, sanitary sewer treatment facilities and sanitary sewer transmission facilities.

PUBLIC FACILITY COSTS - Includes, but is not limited to, costs incurred to provide additional public facility capacity needed to serve new growth and development. Costs attributable to planning, design and construction, land acquisition, land improvement, design and engineering related thereto, including the cost of constructing or reconstructing system improvements or facility expansions; including, but not limited to, the construction contract price, surveying and engineering fees, related land acquisition costs (including land purchasers, court awards and costs, attorney fees, and expert witness fees) and costs associated with the provisions of Section 23C-7(b). Costs may also include expenses incurred for qualified staff or professional consultants necessary to prepare or update the Capital Improvement Plan; and administrative costs equal to five percent (5%) of the total amount of the project costs for system improvements. Public facility costs also include projected interest charges and other finance costs for system improvements if and to the extent the exactions are to be used for the payment of principal and interest on bonds, notes, or other financial obligations issued by or on behalf of the Lexington-Fayette Urban County Government to finance the Capital Improvement Plan. Such costs do not include routine and periodic maintenance expenditures, personnel training, and other operating costs.

ROADS - Streets which have been designated as required roads in the Infrastructure Element of the Expansion Area Master Plan together with all necessary appurtenances; including, but not limited to, bridges and traffic control improvements.

SANITARY SEWER TRANSMISSION LINES AND SANITARY SEWER TREATMENT FACILITIES - Those sanitary sewer system improvements identified in the Expansion Area Master Plan to serve new growth and development activity in the Expansion Areas. These public improvements are, or will be, part of the sanitary sewer system owned and operated by the Lexington-Fayette Urban County Government.

STORM WATER MANAGEMENT FACILITIES - A system improvement which provides watershed-wide management of post-development storm water, including storage, treatment, water quality facilities and discharge runoff.

SYSTEM IMPROVEMENTS - Public facilities which are designed to provide service to the Expansion Area "at large," rather than project improvements which substantially or exclusively benefit only a single project. If an improvement or facility provides or will provide more than incidental service or facilities capacity to persons other than users or occupants of a particular project, the improvement or facility is a system improvement and shall not be considered a project improvement. The character of the improvement shall control a determination of whether an improvement is a project improvement or system improvement; and the physical location of the improvement, on-site or off-site, shall not be considered determinative of whether an improvement is a project improvement or a system improvement. The costs of system improvements, but not project improvements, are calculated as the basis for the determination of the exaction schedule.

23C-3 IMPOSITION OF EXACTIONS - Except as specifically exempted under 23C-9 herein below, any person who, after the effective date of this Article, engages in development activity within a designated Expansion Area shall pay an exaction in the manner and amount set forth herein. No exaction or other fee charge related to the construction of Expansion Area system improvements may be imposed as a condition of development activity approval except pursuant to this Article. No building permit for any development activity shall be issued by the Division of Building Inspection unless and until the required developer exaction has been paid or the Lexington-Fayette Urban County Government has approved a development agreement, pursuant to Section 23C-7(d) herein, setting out in detail how the cost of the system improvements is to be paid.

23C-4 EXACTION DISTRICTS ESTABLISHED - Exaction Districts for each public facility for which an exaction is required pursuant to this Article are hereby established as follows:

23C-4(a) ROAD EXACTION DISTRICTS:

Road Exaction District 2-A/2-B - This exaction district is composed of Expansion Areas 2-A and 2-B.

Road Exaction District 2-C - This exaction district is composed of Expansion Area 2-C.

Road Exaction District 3 - This exaction district is composed of Expansion Area 3.

23C-4(b) OPEN SPACE EXACTION DISTRICT: This exaction district is composed of Expansion Areas 1, 2-A, 2-B, 2-C and 3.

23C-4(c) SANITARY SEWER TREATMENT CAPA- CITY EXACTION DISTRICT: This exaction district is composed of Expansion Areas 1, 2-A, 2-B, 2-C and 3.

23C-4(d) SANITARY SEWER TRANSMISSION CAP- ACITY DISTRICTS:

Sanitary Sewer Transmission Capacity Exaction District 1 - This exaction district is composed of Expansion Area 1.

Sanitary Sewer Transmission Capacity Exaction District 2-A - This exaction district is composed of Expansion Area 2-A.

Sanitary Sewer Transmission Capacity Exaction District 2-B - This exaction district is composed of Expansion Area 2-B.

Sanitary Sewer Transmission Capacity Exaction District 2-C - This exaction district is composed of Expansion Area 2-C.

Sanitary Sewer Transmission Capacity Exaction District 3 - This exaction district is composed of Expansion Area 3.

23C-4(e) PARK EXACTION DISTRICTS:

Park Expansion Exaction District 2-A/2-B - This exaction district is composed of Expansion Areas 2-A and 2-B.

Park Expansion Exaction District 2-C - This exaction district is composed of Expansion Area 2-C.

23C-4(f) STORM WATER MANAGEMENT FACIL- ITIES EXACTION DISTRICTS:

Storm Water Exaction District 2-A - This exaction district is composed of Expansion Area 2-A.

Storm Water Exaction District 2-B - This exaction district is composed of Expansion Area 2-B.

Storm Water Exaction District 2-C - This exaction district is composed of Expansion Area 2-C.

23C-5 COMPUTATION OF THE AMOUNT OF THE EXACTION - The amount of exactions shall be determined by zoning, public facility cost and acreage in accordance with a schedule adopted by resolution of the Lexington-Fayette Urban County Council. Any amendments to the Exaction Schedule, as specified under 23C-5(b), shall also be adopted by resolution of the Council.

3C-5(a) MISCELLANEOUS EXACTION PROVISIONS - The following special circumstances shall be addressed as provided below:

- (1) Inasmuch as land in the Conservation District (CD) zone is proposed for future public acquisition, there shall be no exactions imposed for any use permitted in the CD zone.

- (2) Land developed in the Transition Area (TA) zone shall be subject to an exaction based on the underlying zone.
- (3) The Exaction Schedule shall include an adjustment for the exactions of any EAR-1 property which lies in its entirety within a Scenic Resource Area. The adjustment shall be based proportionally upon the reduced on-site density. Should such density be recaptured under a Density Transfer Right, exactions shall be paid for such unit as a part of obtaining a Certificate of DTR under Article 23A-2(m)(2)(g).
- (4) In the event a zone change is granted to a category where no exaction is shown in the adopted Exaction Schedule, no development activity shall occur until the Urban County Council has amended this Article and/or the Exaction Schedule, as necessary, to create an appropriate exaction.

23C-5(b) REVIEW, ADJUSTMENT AND AMENDMENT OF EXACTIONS - The exactions set forth in this Article are based upon good faith estimates of the costs of acquiring lands for open space, parks, and infrastructure, and the costs of constructing system improvements. The Lexington-Fayette Urban County Government acknowledges that a cost estimate, which as closely as possible approximates the actual construction cost, is in the best interest of the operation of the exaction program. Therefore, beginning four months after the date of the adoption of the resolution establishing the Exaction Schedule, and on a quarterly basis thereafter, the Department of Finance and the Department of Public Works shall review the methodology report and recommend the increase or decrease of all exactions, with the exception of the Open Space Exaction, based upon the actual costs of acquiring properties or interests in properties and the actual costs of constructing system improvements. The methodology for calculation of the estimated public facility cost and exaction shall entail:

- (1) Adjusting the total estimated cost of the facility by factoring the actual costs for system improvements constructed as of the date of the calculation into the estimated cost of the system improvement to the extent those improvements have been constructed;
- (2) Subtracting from this adjusted total estimated facility cost the total committed exactions paid or due as calculated by totaling the exactions on previously recorded subdivision plats; and
- (3) Subsequently recalculating the Exaction Schedule based upon the calculations described under (1) and (2) by apportioning the remaining cost by zone and acreage of all land in the exaction district not accounted for in section 2 above.

Beginning January 1, 2002, and at least at five-year intervals thereafter, the Open Space Exaction shall be subject to such review and adjustment based on the actual cost of acquiring the interest in property. The failure to review such exactions and methodology report shall not invalidate this Article or exactions imposed pursuant to this Article. The Department of Finance shall consult with the Divisions of Engineering, Planning and other Divisions of the Urban County Government, as appropriate, in the review of the methodology report and the determination of the adjustments to the exactions.

23C-6 PAYMENT OF EXACTIONS - Any person required to pay exactions pursuant to this Article shall render such exaction to the Director of Building Inspection prior to the issuance of a building permit, except as permitted herein.

23C-6(a) EXACTIONS DUE - The amount of the exaction applicable to the property shall be shown on the final record plan of each subdivision in the Expansion Area. The calculation of the amount due may include the direct application of approved credits against such exaction, pursuant to Section 23C-7 herein; provide for deferred or phased payment of the exaction if so specified in a development agreement, or for the contribution or dedication of land in lieu of payment of exactions.

23C-6(b) PERMITTED INSTALLMENTS - Except where a development agreement provides otherwise, feepayers shall be entitled to make the entire exaction payment at the time of building permit or to pay in two equal installments. Under this installment option, 50% of the exactions due shall be paid prior to the issuance of the building permit. The second payment shall be made no later than one year from the date of issuance of the building permit. In consideration of such installment payment, the owner shall enter into a contract with the Urban County Government, which shall include agreement to the placement of a lien against the property for the exaction amount outstanding. The lien shall be subordinate to any financing for construction purposes. No interest shall be assessed against such installment payment as long as it is fully paid within one year of the issuance of the building permit. After one year, interest shall accrue on a monthly basis at a rate equal to the current interest rate of the three-month United States Treasury bill, plus 2%.

23C-6(c) DEPOSIT OF FUNDS - All exactions collected pursuant to this Article shall be identified by the Exaction District from which they were collected and promptly transferred for deposit into the appropriate Exaction Account to be held and used as provided for in this Article. Exactions shall be used solely for the purposes specified in this Article.

23C-7 DEVELOPER PROVISION OF SYSTEM IMPROVEMENTS: CALCULATION OF CREDITS AGAINST EXACTIONS - Developers seeking to construct and/or dedicate system improvements or land, and to receive credit for such against exactions otherwise due, shall be subject to the provisions of this section.

23C-7(a) CREDITS AGAINST EXACTIONS - Shall be determined as follows:

- (1) A developer shall construct and dedicate, as necessary, all project improvements required for the development. No credit shall be given for project improvements. A developer shall be entitled to construct all system improvements reflected in the Expansion Area Master Plan for the property proposed for development activity. Stormwater management facilities which are constructed in conformance with the Expansion Area Stormwater Facilities Master Plan may be constructed by the developer, and the cost of such improvement shall be credited as provided herein against exactions which would be otherwise owed. Credits shall be given for the actual cost of the construction of system improvements or contribution or dedication of land as outlined in Section 23C-7(b) by a developer at any time subsequent to the effective date of this Article and required or accepted by the Lexington-Fayette Urban County Government from the developer or predecessor in title for system improvements.
- (2) wishing to claim credits for system improvements shall be subject to the procedures outlined in 23C-7(b) below. A developer shall be entitled to receive exaction credits for the construction of a system Developers improvement only upon executing a "System Improvement Design and Construction Memorandum" or a "Development Agreement" as provided below. The system improvement design and construction memorandum shall be used only for projects not involving "special circumstances," as defined herein. Development agreements shall be required for all other system improvement projects. "Special circumstances," as used herein, shall mean any case where the system improvement involves a material deviation from the Expansion Area Master Plan; deviation from the provisions of Article 23C-7(b), its subsections, or other relevant sections of this ordinance for the calculation of exactions owed; the type or extent of system improvements; the design of the system improvements; the payment of exactions; the application of exaction credits; refunds from an Exaction Fund; the transfer of exaction credits; or the apportionment of costs or construction responsibilities between developers, or between a developer and the Urban County Government.

23C-7(b) SYSTEM IMPROVEMENT DESIGN AND CONSTRUCTION MEMORANDUM - Prior to commencement of the design of system improvements, the developer and the Urban County Government, as represented by the Chief Administrative Officer or authorized agent, shall jointly execute a system improvement

design and construction memorandum. A developer claiming credits for system improvements shall submit to the Chief Administrative Officer a detailed project description, including engineering and construction cost estimates prepared by a licensed professional engineer. In addition, the developer shall submit property appraisals prepared by professional appraisers to determine the cost of land acquisition or right-of-way dedication for system improvements. All construction must be publicly bid and must be carried out in accordance with applicable development and design standards. The Chief Administrative Officer shall refer all land and construction cost estimates to the Exaction Credit Advisory Committee, who shall review all materials and make recommendation to the Chief Administrative Officer as to their appropriateness. The Exaction Credit Advisory Committee shall consist of the following individuals or their designees: the Commissioner of Finance, the Commissioner of Public Works, the Commissioner of Law, the Director of the Division of Engineering, the Director of the Division of Planning, and the Urban County Council Administrator. The Chief Administrative Officer has the right to confirm the amount proposed to be credited by having engineering and construction cost estimates and/or property appraisals prepared for those system improvements, and by having verification of developer expenses claimed. The system improvement design and construction memorandum shall include provisions which shall establish:

- (1) The specific nature and extent of the system improvements to be constructed and eligible for credit.
- (2) That the developer shall receive credit for construction of full or partial system improvements, or for contribution or dedication of land as outlined in this Article. This credit shall take the form of either direct application against the required exaction or as exaction credit certificates in an amount which cannot exceed the eligible credits. Credits shall be permitted to be used as authorized by 23C-7(c)(3) and (4) herein below.
- (3) If the amount of the credit created by such construction, contribution or dedication is in excess of the exaction which would have been otherwise due and owing for that improvement, the developer shall be reimbursed for such excess contribution from the Exaction Fund as provided herein.
- (4) The public bid process to be used for selection of the contractor and estimated cost for the system improvements.
- (5) The developer's management/overhead fee cost to be included in the exaction-eligible cost of the construction equal to 5% of total cost of the system improvements.
- (6) The procedures to be used to submit, evaluate and approve (if warranted) change orders to any contracted system improvement.
- (7) A statement establishing that the actual cost of the system improvement construction and/or dedication as calculated at the time of recording of the plat shall be the basis for any credits. For any system improvements not in place at the time of recording, the cost of the completion shall be covered by surety as provided generally for subdivision improvements in the Land Subdivision Regulations. For these items, the bid price for the completion of such improvements shall be used to calculate the cost of the system improvement. The memorandum shall also provide for verification through documentation required of the developer by the LFUCG; including, but not limited to, periodic submittal of invoices, proof of payment, audits or other means determined necessary by the LFUCG to ensure validity of claimed credit amounts. All such materials shall be referred to the Exaction Credit Advisory Committee, who shall make recommendations to the Chief Administrative Officer. The Chief Administrative Officer shall approve the final amount of such actual costs prior to plat recording.

- (8) A developer proposing credits for land dedication shall present property appraisals prepared by qualified professionals and a certified copy of the most recent property valuation administration assessment of the property to the Chief Administrative Officer to be used in determining the amount of credit. The Chief Administrative Officer shall have a review appraisal prepared by a professional MAI to confirm the accuracy of the appraisals submitted by the developer, and shall refer all such materials to the Exaction Credit Advisory Committee, who shall make a recommendation to the Chief Administrative Officer.
- (9) A statement affirming the understanding that no credits shall be given for project improvements.
- (10) That the total exactions required under this ordinance and the amount of exactions due after the application of any credits authorized under 23C-7(b)(2) or provisions of a development agreement shall be shown on the final plat of the subdivision. The exaction rate schedule to be used shall be the one in effect as of the date the Division of Engineering transmits its certified original of the final plat to the Division of Planning for final certification, provided the plat is recorded within 30 days of that date; otherwise, the net exaction shall be calculated upon any amended rate schedule adopted by the Urban County Council in the intervening time.

23C-7(c) CLAIMING AND APPLICATION OF CREDITS - The application of credits shall be as follows:

- (1) The dollar amount of any credits shall be applied either as a credit against exactions due for the development providing the system improvement, or for the issuance of exaction credit certificates as outlined under 23C-7(b)(2) above.
- (2) Credits must be claimed by no later than the time of the certification of the final record plan. Any credits not so claimed shall be deemed waived.
- (3) The credits for roads, parks, open space or storm water management facilities may be applied against all exactions for roads, parks, stormwater management facilities and open space owed by the developer with respect to the development. To the extent that the total credits for roads, parks, open space or storm water management facilities exceed exactions due for roads, parks stormwater management facilities and open space with respect to the developer's property, the development agreement may provide for the developer to receive a refund from the exaction fund, as outlined in 23C-7(c)(8) below.

Credits for roads, parks, stormwater management facilities and open space may be applied as follows:

- a. Credits earned in either Expansion Area 2-A or 2-B may be applied only against stormwater facilities, road, park and open space exactions in either Expansion Area 2-A or 2-B.
- b. The stormwater credit is only applicable within the specific exaction district as noted in Table A.
- c. Credits earned in Expansion Area 2-C may be applied only in Expansion Area 2-C.
- d. Credits earned in Expansion Area 3 may be applied only in Expansion Area 3.

Table A

Application of Credits for System Improvements (Other than Sanitary Sewer Capacity and Transmission)

<i>Credits for system improvements constructed in Expansion Area:</i>	<i>May be applied against exactions due in the following Expansion Districts:</i>
Expansion Area 1	N/A
Expansion Area 2-A	Roads 2-A and 2-B Open Space Parks 2-A and 2-B Storm Water Management 2-A
Expansion Area 2-B	Roads 2-A and 2-B Open Space Parks 2-A and 2-B Storm Water Management 2-B
Expansion Area 2-C	Roads 2-C Open Space Parks 2-C Storm Water Management 2-C
Expansion Area 3	Roads 3

Table B

Application of Exaction Credits for Sanitary Sewer Transmission and Treatment Capacity

<i>Credits for Sanitary Sewer Transmission and Capacity system improvements constructed in Expansion Area:</i>	<i>May be applied against exactions due in the Sanitary Sewer Treatment Capacity District and in the following Transmission Capacity Districts:</i>
Expansion Area 1	Sanitary Sewer Transmission Capacity in Expansion Area 1
Expansion Area 2-A	Sanitary Sewer Transmission Capacity in Expansion Area 2-A
Expansion Area 2-B	Sanitary Sewer Transmission Capacity in Expansion Area 2-B
Expansion Area 2-C	Sanitary Sewer Transmission Capacity in Expansion Area 2-C
Expansion Area 3	Sanitary Sewer Transmission Capacity in Expansion Area 3

- (4) The credits for sanitary sewer transmission capacity may only be applied against exactions due for sanitary sewer transmission capacity in the Expansion Area from which credit originates, or against exactions due for sanitary sewer treatment capacity in any Expansion Area.
- (5) If the area proposed for development includes lands designated for parks in the Expansion Area Master Plan, the developer shall dedicate such lands to the Lexington-Fayette Urban County Government with credit given for the value of the land against the required exaction. If an area proposed for development includes land which is located outside the horizontal limits of the greenway and which is designated in the Expansion Area Stormwater Facilities Master Plan for stormwater management facilities, the developer shall dedicate such land. The developer shall obtain a credit for the value of such lands against any open space, park or road exactions which may be due. The value of such credit shall be computed as set forth in Article 23C-7(b)(7) and shall be applied in the same manner as credits for constructed system improvements.
- (6) In cases where the land proposed for development is entirely or substantially in an area designated in the Expansion Area Master Plan for park land, and the extent of the designation is such as to render the development of the land infeasible, the developer may enter into an agreement with the Lexington-Fayette Urban County Government establishing interim uses of the property in conformance with the Conservation District (CD) Zone, timing of acquisition, schedule of payments, and other related uses.
- (7) In the event a building permit is abandoned, credits shall be given for the full amount of any exactions paid against future exactions for the same parcel of land paid upon issuance of such building permit. A building permit shall be deemed

abandoned if no construction has been commenced prior to the expiration of the building permit.

- (8) If the application of all credits against exactions exceeds the amount of the exactions due, the developer shall be repaid for the actual cost of system improvements from the Exaction Fund as monies become available with the order of payment to be the order of the date of award of the credit. Alternatively, the developer may be reimbursed in Exaction Credit certificates, which shall be used as specified within this Article. Developers desiring any other arrangement shall be required to enter into a development agreement with the LFUCG as outlined below.

23C-7(d) DEVELOPMENT AGREEMENTS - A feepayor may propose, and the Lexington-Fayette Urban County Government may approve, a development agreement which provides for the deferred or phased payment of exactions which were not eligible for application of credits, as provided under 23C-7(c), provides for credits, provides for the dedication of land in lieu of cash payment, provides for the construction of system improvements in lieu of cash payment, provides for the repayment of credits from the exaction fund, provides for payment of interest, provides for the issuance of exaction credit certificates, or provides for any combination thereof. Any developer contemplating an activity which involves a development agreement shall submit a proposed agreement to the Chief Administrative Officer, who shall solicit comments from the Exaction Credit Advisory Committee for the determination of compliance with the provisions of this Article and the Expansion Area Master Plan. The Chief Administrative Officer shall review the proposed development agreement and transmit the proposed development agreement, together with a recommendation and the comments of the Exaction Credit Advisory Committee, to the Lexington-Fayette Urban County Council for appropriate action. The Lexington-Fayette Urban County Council shall not approve a development agreement unless it determines that the development agreement satisfies the intent and purpose of this Article, is in compliance with the Expansion Area Master Plan, is in the best interest of the Lexington-Fayette Urban County Government and is consistent with the public health, safety and welfare of the citizens of Lexington-Fayette County. The Lexington-Fayette Urban County Council has sixty (60) days from receipt of the fully completed draft development agreement to take final action on the development agreement.

23C-7(e) - Exaction Credit Certificates are transferable from one developer to another, from a developer to a property owner, and from one project to another, provided that such credits only be used in conformance with 23C-7(c)(3, 4, and 5), or as authorized under a development agreement pursuant to Article 23C-7(d).

23C-8 USE OF FUNDS - Funds collected as exactions shall be used for system improvements. No funds shall be used for periodic or routine maintenance or repair of capital facilities. Exactions shall be used exclusively for system improvements within the Exaction District which contains the project for which the fees were paid or for reimbursement from credits against exactions as authorized elsewhere in this Article. In the case of open space exactions, funds collected shall be used to acquire open space; including, but not limited to, conservation easements in the Rural Service Area, with priority to be given to land within a one-mile radius of the boundary of the Expansion Area from which the funds were collected or pursuant to a duly adopted rural land management program. The open space funds may also be used as reimbursement for credits against exactions as authorized elsewhere in this Article. Exaction funds collected for Sanitary Sewer Transmission Capacity and for Sanitary Sewer Treatment Capacity shall be transferred to the Sanitary Sewer fund established by the Lexington-Fayette Urban County Government for sanitary sewer system improvements designed to increase capacity or otherwise accommodate sewage generated in the Expansion Areas.

Each fiscal year the Department of Finance shall present to the Lexington-Fayette Urban County Council an annual report describing the amount of exactions collected, encumbered and used during the preceding year. Monies, including any accrued interest, not encumbered in any fiscal period shall be retained in the same Exaction

Fund(s) until the next fiscal year, except as provided in Section 23C-9 below. Exactions may be used for the payment of principal and interest on bonds, notes or other financial obligations issued by or on behalf of the Lexington-Fayette Urban County Government to finance system improvements.

23C-9 EXEMPTIONS - After an exaction requirement has been paid, no further exactions shall be required for any development activity. In addition, the following shall be exempted from payment of exactions:

- (a) The alteration or expansion of an existing building or use of land where no additional living units are created, where the use is not changed, where no development activity takes place, or where the proposed use shall not result in need for increased public facilities.
- (b) The construction of accessory buildings, excluding accessory dwelling units; attached garages in conjunction with a residential use; additions to structures existing at the time of adoption of this Article; or structures which will not produce additional impact on the roads, parks, open space, storm water management facilities, sanitary sewer transmission lines and sanitary sewer treatment facilities over and above those produced by the principal building, accessory dwelling units, or use of the land.
- (c) The replacement of a building, mobile home or structure that was in place on the effective date of this Article, or the replacement of a building, mobile home or structure that was constructed subsequent thereto and for which the correct exactions had been paid or otherwise provided for, with a new building, mobile home, or structure of the same use; provided that no additional impact on the roads, parks, open space, storm water management facilities, and sanitary sewer transmission lines and sanitary sewer treatment facilities will be produced over and above those produced by the original use of the land.
- (d) The construction, alteration or expansion of publicly owned and operated school buildings or other public buildings owned, operated and occupied by local, state, or federal government agencies.
- (e) Affordable housing shall be eligible for a reduced exaction if the developer can demonstrate that the housing to be constructed will be used to provide housing for low income persons for a period of no less than fifteen (15) years. Factors to be considered in determining the amount of reduction shall include the size and scope of the project, whether other funds are available to pay for the portion of the developer exaction which is otherwise due, and whether the proposal will fulfill established goals or policies in the Comprehensive Plan and the Expansion Area Master Plan to ensure a wide range of housing options to the citizens of Lexington-Fayette County. The determination of the reduction shall be by appeal to the Exaction Appeals Committee, as outlined in Article 23C-12.
- (f) Developments located within a Scenic Resource Area which are not included in the pre-calculated reduced exaction in the Exaction Schedule shall be eligible for a reduced exaction if the developer can demonstrate that the permitted units to be developed are so low as to cause an unfair burden relative to the impact of the development. Factors to be considered in determining the amount of the reduction shall include the size and scope of the project, whether or not the right to sell density transfer rights has been forfeited, and whether the proposal will fulfill established goals or policies in the Comprehensive Plan and the Expansion Area Master Plan. The determination of the reduction shall be by appeal to the Exaction Appeals Committee as outlined in Article 23C-12.
- (g) Any person claiming exemption(s) pursuant to Section 23C-9(a) through (f) above shall submit to the Chief Administrative Officer information and documentation sufficient to permit a determination of whether such exemption claimed is proper and, if so, the extent of such exemption. Exemptions must be applied for by no later than the time of the application for a building permit. Any exemptions not so applied for shall be deemed waived.

23C-10 EXACTION FUNDS - There is hereby established an exaction fund, containing separate accounts for each Exaction District as set forth in Section 23C-4. Funds shall be deposited and maintained in one or more interest bearing accounts. Interest earned on funds shall be funds of the account on which it is earned and is subject to all restrictions imposed by Section 23C-8. Funds withdrawn from these accounts must be used in accordance with the provisions of Section 23C-8.

23C-11 REFUNDS - Exactions collected shall be encumbered for public facilities cost within six (6) years of the date of collection. In the absence of a development agreement, and in the event the exactions are not encumbered within six (6) years from the date of collection, the Lexington-Fayette Urban County Government shall refund the amount of the exaction to the feepayor. The exactions collected pursuant to this Article shall be returned to the feepayor through submission of a refund application to the Department of Finance by no later than the calendar quarter following seven (7) years from the date the exactions were paid. The refund application shall include the following information:

- (a) a notarized sworn statement that the feepayor paid the exactions for the property and the amount paid;
- (b) a copy of the dated receipt issued by the Lexington-Fayette Urban County Government for payment of the exactions;
- (c) a certified copy of the latest recorded deed for the property;
- (d) a copy of the most recent ad valorem tax bill; and
- (e) a sworn statement of entitlement.

Within thirty (30) working days of receipt of a refund application, the Department of Finance shall determine if it is complete. If the Department of Finance determines the refund application is not complete, the Department of Finance shall send a written statement specifying the deficiencies by mail to the person submitting the refund application. Unless the deficiencies are corrected, the Department of Finance shall take no further action on the refund application.

When the Department of Finance determines the refund application is complete, it shall review it within fifteen (15) working days, and shall approve the proposed refund if it determines the feepayor has paid an exaction which the Lexington-Fayette Urban County Government has not spent or encumbered within six (6) years from the date the exactions were paid. The exactions shall be returned, less five percent (5%) of the total, to defray the costs of administration. Feepayors who are owed a refund for exactions paid or credits given shall receive refunds in the order, by date that contributions were made.

23C-12 ADMINISTRATIVE APPEALS - Shall be as follows:

- (a) Any person directly aggrieved by a decision of the Lexington-Fayette Urban County Government with respect to any of the following determinations, or is seeking an adjustment to exactions as provided elsewhere in this Article, shall have the right to appeal the decision to the Exaction Appeals Committee:
 - (1) the imposition of an exaction,
 - (2) the amount of an exaction,
 - (3) the entitlement to and/or the amount of credits to an exaction,
 - (4) the entitlement to an exemption from an exaction,
 - (5) the entitlement to and/or the amount of a refund of an exaction, or,
 - (6) the adjustment of exactions under 23C-5(b), 23C-9(e) or 23C-9(f).

The Committee shall consist of a representative of the Mayor's Office, the Commissioner of Public Works, the Commissioner of Finance, and the Commissioner of General Services (or their designated representatives), one

member of the Urban County Council, and one member of the Planning Commission. The Committee shall forward its recommendations on any appeal to the Urban County Council as set forth under 23C-12(d) herein.

Prior to any appeal to the Exaction Appeal Committee, the aggrieved party shall file a request for reconsideration with the Department of the Lexington-Fayette Urban County Government which took the action giving rise to the appeal. Such Department shall take final action affirming, modifying, or denying the request within fifteen (15) working days. The file shall constitute the record and shall include all documentation submitted by the developer, as well as any information including appraisals or estimates prepared for the Lexington-Fayette Urban County Government, and which formed a basis for the Department's decision.

- (b) Any appeal shall be taken within fifteen (15) working days of the reconsideration decision by filing a notice of appeal with the Exaction Appeal Committee, setting forth the grounds therefor. The Department shall forthwith transmit to the Exaction Appeal Committee all papers constituting the record upon which the action appealed from is taken. The Exaction Appeal Committee shall thereafter establish a reasonable date and time for a hearing on the appeal, and give due notice thereof to the parties in interest. Any party taking an appeal shall have the right to appear at the hearing to present evidence and may be represented by counsel. The Exaction Appeal Committee shall render a decision granting, modifying, or denying the appeal within ten (10) working days of the hearing.
- (c) A developer may pay an exaction under protest to obtain a building permit, and by making such payment shall not be estopped from exercising his right of appeal or receiving a refund of any amount determined to have been improperly collected.
- (d) The Exaction Appeal Committee shall be required to maintain records of its actions, including minutes of any official meeting. Such records shall be available for public inspection, and shall be distributed on a routine basis to the Planning Commission and the Urban County Council.

23C-13 PENALTY AND ENFORCEMENT - Any violations of this Article shall be subject to the penalties provided in Article 5 of the Zoning Ordinance. In addition to those remedies, the Lexington-Fayette Urban County Government retains the right to enforce the provisions of this Article by filing an enforcement action in civil court. Knowingly furnishing false information to the Lexington-Fayette Urban County Government on any matter relating to the administration of this Article shall constitute a violation thereof.

Section 12-That Article 24 of the Zoning Ordinance of the Lexington-Fayette Urban County Government shall hereby be amended as follow:

AGRICULTURAL & RURAL CORRIDOR OVERLAY ZONES

24-1 INTENT - It is recognized that this Zoning Ordinance provides zones which allow many types of residential, professional office, business, and industrial uses and provides minimum standards in each zone to ensure the health, safety, and welfare of the entire community. It is also recognized that the application of these more traditional zoning categories along lands adjacent to transportation routes in the Rural Service Area of Lexington-Fayette County can, at times, hamper innovative but proper regulatory and management approaches along these corridors.

This Article is intended to establish overlay zones, which recognize the special characteristics of all (or most) lands along such rural transportation arteries. Customary standards may need to be relaxed in these zones, in some instances, and strengthened in others, depending upon the information gathered and the policies set forth in the adopted Comprehensive Plan. While the traditional zones will continue to be available, the new overlay zones established in this Article will provide an alternative to the traditional zones that exist elsewhere in this Ordinance.

It is further intended that these zones be established to facilitate proper regulation and management along transportation corridors. These zones are to promote the efficient use of existing and proposed agricultural lands, to minimize land use conflicts, and to

respect existing and planned agricultural facilities. At the same time, these zones must also ensure a safe and efficient roadway system, and ensure that new development will further the implementation of the adopted Comprehensive Plan.

24-2 ESTABLISHMENT OF AGRICULTURAL OVER-LAY ZONES AND RURAL CORRIDOR OVERLAY ZONES - Following their adoption, the regulations of each agricultural overlay zone shall be included as an appendix to this Article. Thus, the PARIS PIKE/LEXINGTON ROAD CORRIDOR OVERLAY ZONE shall be Article 24, Appendix A, and subsequent overlay zones shall be designated Appendix B, Appendix C, etc.

24-3 REGULATIONS IN OVERLAY ZONES - The regulations adopted in each agricultural overlay zone shall be in keeping with the overall intent of such zones and shall include, but not be limited, to the following:

24-3(a) INTENT - A statement of the purposes and objectives of the zone.

24-3(b) PERMITTED USES - A listing of the allowable uses permitted in the zone.

24-3(c) PROHIBITED USES - A listing of the uses not permitted in the zone.

24-3(d) SITE CRITERIA AND/OR LOCATIONAL STANDARDS - The specific characteristics of the size or location of the overlay zone.

24-3(e) RELATIONSHIP TO THE COMPREHENSIVE PLAN - Statements and requirements as necessary to define the relationship of the Comprehensive Plan (including the applicable Small Area Plan, Corridor Plan, etc.) to the allowable or prohibited uses.

24-3(f) DESIGN STANDARDS - The lot, yard, height, access, parking, open space, and/or other requirements deemed necessary to fulfill the intent of the particular overlay zone.

24-3(g) REVIEW PROCEDURE - The procedure to be followed in the application of the zone, if necessary.

24-4 CREATION OF AGRICULTURAL OVERLAY ZONES - A proposal to create a new agricultural overlay zone shall be processed and reviewed as a Zoning Ordinance text amendment, as provided in Article 6. An agricultural overlay zone may be a zoning designation with requirements in addition to the remaining underlying zone classification.

PARIS PIKE/LEXINGTON ROAD CORRIDOR OVERLAY ZONE

24A-1 INTENT - The intent of this corridor overlay zone is to...

- 1) implement the recommendations of the Paris Pike Corridor Small Area Plan (excluding the designated transition areas) &
- 2) regulate permitted land uses in the corridor in conjunction with an inter-local agreement between Bourbon County, the City of Paris, and the Lexington-Fayette Urban County.

This corridor overlay zoning classification is intended for lands adjoining the Paris Pike between Johnston Road (to the south) and the Paris City limits (to the north); and the regulations hereunder shall be established in addition to the zone classifications shown on the zoning map atlas for the subject areas, and the applicable regulations contained in this Zoning Ordinance. The use, dimensions and other requirements for said zones, as provided in the Zoning Ordinance, shall apply unless further restricted hereunder. Where there are conflicts between the regulations hereunder, and those contained elsewhere in the Zoning Ordinance, the more restrictive shall apply.

24A-2 PRINCIPAL USES PERMITTED - Those uses listed as permitted in the zone classification underlying the Paris Pike/Lexington Road Corridor Overlay Zone, unless listed as a prohibited use below.

24A-3 ACCESSORY USES PERMITTED - Those uses listed as accessory in the zone classification underlying the Paris Pike/Lexington Road Corridor Overlay Zone, unless listed as a prohibited use below (those uses customarily accessory, clearly incidental and subordinate to permitted uses).

24A-4 CONDITIONAL USES - Those uses listed as conditional (permitted only with Board of Adjustment approval) in the zone classification underlying the Paris Pike/Lexington Road Corridor Overlay Zone, unless listed as a prohibited use below.

24A-5 PROHIBITED USES - Those uses listed as prohibited in the zone classification underlying the Paris Pike/Lexington Road Corridor Overlay Zone.

1. Advertising signs (billboards).
2. Aircraft landing strips.
3. Airports.
4. Asphalt plants.
5. Bait shops.
6. Commercial cemeteries, crematories, columbariums, mausoleums, including animal burial grounds. (Non-commercial cemeteries, crematories, columbariums, mausoleums, including animal burial grounds, are not prohibited under this section).
7. Additional places of religious assembly; except that existing places of religious assembly may expand with approval of the Board of Adjustment up to a total of 10,000 square feet.
8. Commercial composting.
9. Concrete mixing.
10. Above-ground facilities for the extraction of crude petroleum or natural gas and mining of metal, anthracite, lignite or bituminous coal.
11. Funeral home.
12. Commercial garages, storage sheds, parking lots, and vehicle fueling facilities.
13. Golf clubs and golf courses or related facilities, including driving ranges.
14. Except as ancillary to row crop production, commercial greenhouses and plant nurseries.
15. Kindergartens, nursery schools, and child care centers for more than twelve (12) children.
16. Landfills.
17. Above-ground facilities for mining activities and quarrying of non-metallic minerals.
18. Mobile homes.
19. Non-service facilities of public utilities when not incidental to a service facility as provided in KRS 100.324.
20. Commercial outdoor recreational facilities such as the following: golf courses, sportsmen's farms, riding stables, fishing lakes, swimming pools, tennis courts, campgrounds, zoological gardens, outdoor rifle and other firearm ranges, native animal game preserves, outdoor rodeos, hunting and trapping (non-commercial outdoor recreational facilities are not prohibited under this section).
21. Commercial outdoor athletic facilities (non-commercial outdoor athletic facilities are not prohibited under this section).
22. Parking lots and structures, except as accessory to a business or office use.

23. Radio or television studios and offices and associated equipment.
24. Radio, telephone or television transmitting or relay facilities.
25. Rehabilitation homes.
26. Schools for academic instruction, including accessory dormitories, other than those for agricultural instruction which are incidental to a farming operation.
27. Temporary cellular telephone transmitting facility.
28. Utilities, pump stations, utility offices, substation offices
29. Commercial woodlots.

24A-6 LOCATIONAL STANDARDS - While the Paris Pike/Lexington Road Corridor Overlay Zone is intended to apply to land fronting along Paris Pike/Lexington Road for a depth of approximately one thousand (1,000) feet from the right-of-way, the boundaries, dimensions and locations of this overlay zone are subject to review and approval by the appropriate legislative bodies in Bourbon and Fayette Counties. From time to time, especially resulting from changes in the location of the road's rights-of-way, there may be adjustments made in the application of the corridor overlay zone.

24A-7 MINIMUM DESIGN STANDARDS

24A-7(a) REVIEW - Major subdivisions and major development plans which are proposed within the Paris Pike/Lexington Road Corridor Overlay Zone shall be reviewed by the Paris Pike Corridor Commission, as outlined in the inter-local agreement between Bourbon County, the City of Paris, and the Lexington-Fayette Urban County. Following its review, the Paris Pike Corridor Commission may choose to advise the appropriate Planning Commission whether to grant approval, conditional approval, approval with modifications or disapproval of the proposed subdivision or development plan. The Paris Pike Corridor Commission shall state the reasons for any recommendation. In the event the Corridor Commission cannot meet between the filing of a subdivision or development plan and its scheduled consideration by the appropriate Planning Commission, the plan should not be delayed for consideration based upon this factor alone.

24A-7(b) ACCESS - Access to Paris Pike/Lexington Road shall be in conformance with the designated access points and cross-over points developed in the roadway design plans. No additional direct access points to Paris Pike/ Lexington Road shall be permitted unless approved first by the Planning Commission (after considering the recommendation of the Paris Pike Corridor Commission) and then with final approval by the Kentucky Transportation Cabinet. Access shall also be in conformance with the applicable provisions of the Subdivision Regulations.

24A-8 LOT, YARD AND HEIGHT REQUIREMENTS

24A-8(a) MINIMUM LOT AREA - Those listed as minimum or required in the zone classification underlying the Paris Pike/Lexington Road Corridor Overlay Zone.

24A-8(b) MINIMUM LOT WIDTH - Those listed as minimum or required in the zone classification underlying the Paris Pike/Lexington Road Corridor Overlay Zone, if applicable.

24A-8(c) MINIMUM LOT FRONTAGE - 500 feet for single family detached residences and conditional uses which rely upon the Paris Pike/Lexington Road for frontage; otherwise, those listed as minimum or required in or required in the zone classification underlying the Paris Pike/Lexington Road Corridor Overlay Zone.

24A-8(d) MINIMUM FRONT YARD REQUIRED - 300 feet from the Paris Pike/Lexington Road for single family residences and conditional uses; otherwise, those listed as minimum or required in the zone classification underlying the Paris Pike/Lexington Road Corridor Overlay Zone.

24A-8(e) MINIMUM SIDE & REAR YARDS REQUIRED - Those listed as minimum or required in the zone classification underlying the Paris Pike/Lexington Road Corridor Overlay Zone.

24A-8(f) MAXIMUM BUILDING HEIGHT - Those listed as maximum in the zone classification underlying the Paris Pike/Lexington Road Corridor Overlay Zone.

24A-9 PROCEDURE - The procedure for obtaining a Zoning Map Amendment to the Paris Pike/Lexington Road Corridor Overlay Zone shall be the same as those procedures outlined in this Zoning Ordinance, and the applicable provisions of KRS 100 for a zoning map amendment. In the event a future amendment is proposed to the text of this zoning regulation, notice shall be given by first class mail in advance of any scheduled public hearing to the property owners of land to which the Paris Pike/Lexington Road Overlay Zone has been applied.

APPENDIX 24B AGRICULTURAL MARKET (AM-1) OVERLAY ZONE

24B-1 INTENT - This zone is established to promote the agricultural industry, which is vital to the economy of Lexington-Fayette County. However, some of those uses that are integral to the agricultural economy may not necessarily be agricultural uses. Uses such as livestock markets, horse sales facilities and horse race tracks are recognized as providing a benefit to the surrounding agricultural community, but must be appropriately located throughout the community so as not to be a detriment to the surrounding agricultural areas which they are to serve. In order to provide appropriate locations for these operations and their accessory uses, the Agricultural Market (AM-1) Overlay Zone is hereby created to accompany lands located in an Agricultural Rural (A-R) zone that are not designated for future residential uses.

24B-2 AGRICULTURAL MARKETS DEFINED - These facilities provide for the large scale marketing operations of agricultural products (such as livestock markets) and some agricultural-entertainment uses, such as horse race tracks. Agricultural Markets are generally large facilities of at least forty (40) acres in size.

24B-3 PRINCIPAL PERMITTED USES - The uses allowed in this overlay zone are those listed as permitted in the zone classification underlying the AM-1 zone, unless listed as a prohibited use in Article 24B-6. In addition, the following uses are also permitted in the AM-1 zone:

1. Livestock markets and stockyards.
2. Horse race tracks with allotted race meets, and horse riding and training facilities.
3. Horse sales establishments.

24B-4 ACCESSORY USES PERMITTED - Those uses that are listed as accessory uses in the zone classification underlying the AM-1 zone, meaning they are clearly subordinate and incidental to principal permitted uses, are those also allowed in this overlay zone, unless listed as a prohibited use in Article 24B-6. The aggregate of all accessory uses in an AM-1 zone may not exceed twenty-five percent (25%) of the total square footage of the principal structure on the property, or 40,000 square feet, whichever is less; and except as otherwise provided, shall be located within the principal building. In addition, the following accessory uses are also permitted in the AM-1 zone, but only when incidental and subordinate to a principal use permitted under Article 24B-3 that is not listed as permitted in the zone classification underlying the AM-1 zone:

1. Parking areas and loading docks.
2. Accessory offices for government agencies related to agriculture, banking, insurance and financial institutions.
3. Livestock and grain commodity trading office.
4. One (1) coffee shop and/or restaurant not to exceed five thousand (5,000) square feet, or five per cent (5%) of the total floor area, whichever is less.
5. Veterinary clinic, including the sale of livestock pharmaceutical supplies.
6. Meeting rooms, not to exceed five percent (5%) of the total floor area.

7. One (1) dwelling unit for owners, operators, or employees of a permitted use, which may be in a separate structure.
8. One (1) dwelling unit for watchmen or caretakers, which may be in a separate structure.
9. Outdoor lighting, but only when directed away from and shielded from adjacent agricultural and residential areas.
10. Sale of agricultural products produced on the premises.
11. One (1) gift shop not to exceed two thousand five hundred (2,500) square feet, or five percent (5%) of the total floor area, whichever is greater.
12. Display area for farm machinery/equipment, provided that no on-site sales shall be permitted.
13. Retail sale of agricultural products, supplies and related items, including the acceptance of orders for bulk agricultural supplies, with no on-site storage of such supplies, not to exceed five thousand (5,000) square feet.
14. Indoor Retail Farmers Market

24B-5 CONDITIONAL USES - The uses listed as conditional (permitted only with Board of Adjustment approval) in the zone classification underlying the Agricultural Market (AM-1) Overlay zone, unless listed as a principal permitted or prohibited use in this Article. In addition, approval of the following uses can also be sought from the Board of Adjustment:

1. Outdoor Retail Farmers Market.

24B-6 PROHIBITED USES - The uses listed as prohibited in the zone classification underlying the Agricultural Market Overlay Zone, except as otherwise permitted herein. However, the following uses are prohibited in the AM-1 overlay zone, regardless of their regulation in the underlying zone classification:

1. Advertising signs, as defined in Article 17 herein (aka: billboards).
2. Aircraft landing strips.
3. Airports.
4. Asphalt plants.
5. Commercial cemeteries, crematories, columbariums, mausoleums, including animal burial grounds.
6. Places of religious assembly.
7. Concrete mixing.
8. Above-ground facilities for the extraction of crude petroleum or natural gas and mining of metal, anthracite, lignite or bituminous coal.
9. Funeral home.
10. Kindergartens and nursery schools.
11. Landfills.
12. Above-ground facilities for mining activities and quarrying of non-metallic minerals.
13. Mobile homes.
14. Non-service facilities of public utilities when not incidental to a service facility as provided in KRS 100.324.
15. Rehabilitation homes.
16. Commercial woodlots.
17. Family child care.
18. Spreading of any animal waste upon land outdoors in an AM-1 zone.

24B-7 LOCATIONAL STANDARDS - An AM-1 zone may be established only upon land that meets two or more of the following criteria:

1. The property shall be located within one (1) mile of the point of intersection of the centerlines of an interstate interchange with a state or federal highway (excluding the two interchanges of Interstate 75 with Interstate 64), provided the property has lot frontage and access on that same state or federal highway, so long as the access is also within one (1) mile of that interchange; and/or...
2. The portion of the property wherein site improvements are proposed is not located on land within the Urban Service Area that is recommended for a residential use, nor in an identified environmentally sensitive area, including any wellhead protection area; and/or...
3. The property was approved prior to August 28, 2003 for a conditional use permit by the Board of Adjustment for a horse sales facility, a horse training facility or a horse race track.

24B-8 RELATIONSHIP TO THE COMPREHENSIVE PLAN - The location of an AM-1 zone must be based upon furthering the goals, objectives and land use policies of the Comprehensive Plan for Lexington-Fayette County. Any application for an AM-1 zone should be accompanied by a detailed statement from the applicant to this effect, which shall be submitted at the time of the application.

24B-9 SITE STANDARDS – Any parcel considered for an AM-1 zone must meet all of the following site criteria:

1. The property shall be at least forty (40) acres in size.
2. The property must have easy access to a state or federal highway, with that access approved by the Kentucky Transportation Cabinet, or the LFUCG Division of Traffic Engineering, as appropriate. All roads to the site should be of sufficient width, and constructed to safely handle all sizes of trucks when fully loaded during all weather conditions.
3. The property must be at least three hundred (300) feet from any property in a residential zone, or any property designated as either a Rural Settlement (RS) land use or as an Existing Rural Residential (ERR) land use in the adopted Comprehensive Plan for Lexington-Fayette County.

24B-10 MINIMUM DESIGN STANDARDS

24B-10(a) ENCLOSED BUILDINGS REQUIRED FOR SOME USES - All sales and marketing of livestock, and all horse sales shall be conducted in an enclosed facility. All pre-sale and post-sale handling of livestock shall take place under roof in a facility enclosed by a combination of fences and gates in order to secure livestock while allowing adequate ventilation and air circulation.

24B-10(b) PROPER SITE LANDSCAPING REQUIRED - All new facilities proposed in the AM-1 overlay zone must be landscaped and screened, if those facilities are visible from adjoining properties. Article 18 may be used to plan the proposed screening of loading docks and vehicular use areas, but the Planning Commission may impose additional screening requirements and landscape buffers as necessary.

24B-10(c) ENVIRONMENTALLY SENSITIVE AREAS ARE TO BE AVOIDED - Site improvements such as buildings, underground and above-ground storage tanks, septic sewage disposal systems, and all truck parking and loading areas shall be located outside of any environmentally sensitive area, including any wellhead protection area. In addition, storm water management shall be provided pursuant to the requirements of the LFUCG Engineering Manuals; and storm water must be treated appropriately prior to its discharge, and directed away from environmentally sensitive areas and known karst geologic features. Muck piles are prohibited in all environmentally sensitive areas.

24B-10(d) APPLICABLE LAWS MUST BE MET - All facilities must be operated at all times in compliance with applicable federal, state and local laws and regulations, including those pertaining to noise, air and water quality.

24B-10(e) LOT AND YARD REQUIREMENTS - Those listed as minimum or required in the zone classification underlying the Agricultural Market (AM-1) Overlay Zone shall apply. However, no principal or accessory building for uses permitted under Article 24B-3, that are not listed as permitted in the zone classification underlying the AM-1 zone, may be located closer than three hundred (300) feet:

- (1) from a residence on a lot under different ownership;
- (2) from any property designated on the National Register of Historic Places.

24B-10(f) MAXIMUM BUILDING HEIGHTS - Those listed as maximum in the zone classification underlying the Agricultural Market (AM-1) Overlay Zone, or forty (40) feet, whichever is greater.

24B-10(g) SIGNAGE RESTRICTED - All signs shall be regulated as per the zone classification underlying the AM-1 zone, except that all freestanding signs are to be limited to the principal use and not for the purposes or identification of any accessory use. They may be up to a maximum of twenty (20) feet in height. However, the maximum height and location of all proposed freestanding signs must be identified on any required development plan.

In addition to allowable freestanding signs, in an AM-1 zone, non-illuminated or indirectly illuminated wall mounted signs are permitted, not to exceed five percent (5%) of the wall area to which they are attached, provided the signs are for the principal use and not for the purposes or identification of any accessory use.

24B-10(h) REQUIRED OPEN SPACE - No limitation, except for all uses permitted under Article 24B-3 above that are not listed as permitted in the zone classification underlying the AM-1 zone, then forty percent (40%) of the lot.

24B-11 PROCEDURE - The procedure for obtaining a Zoning Map Amendment to the AM-1 Zone shall be the same as those procedures outlined in this Zoning Ordinance, and the applicable provisions of KRS 100 for a zoning map amendment. In addition, the following shall also be required in an AM-1 zone:

24B-11(a) PRELIMINARY DEVELOPMENT PLAN REQUIRED - A preliminary development plan shall be submitted with the application for a Zoning Map Amendment with the information as specified in Article 21 herein.

24B-11(b) FINAL DEVELOPMENT PLAN REQUIRED - Within two (2) years of approval by the Urban County Council of any AM-1 Zoning Map Amendment, unless an extension is granted by the Commission, the applicant shall submit a final development plan to the Commission for its review and approval. The final development plan shall submit a final development plan to the Commission for its review and approval. The final development plan shall show the information as specified by Article 21 herein. The Commission shall approve, conditionally approve, or disapprove a final development plan within ninety (90) days after the applicant submits the development plan, unless a longer period of time is agreed to by the applicant.

24B-11(c) OPERATIONAL PLANS REQUIRED - With the submission of any development plan, other than minor amendments as regulated by Article 21-7 herein, where land uses permitted under Article 24B-3 above that are not listed as permitted in the zone classification underlying the AM-1 zone are proposed for a site, an Operational Plan must also be submitted for review by the Commission. Where the Commission deems appropriate, a Kentucky No Discharge Operational Permit (KYNDOP), or other appropriate permit from the Kentucky Division of Water may be required prior to approval of an Operational Plan.

The Operational Plan shall address the following:

1. Provisions for animal and/or product waste disposal, subject to all applicable

local, state and federal requirements.

2. Provisions for sewage disposal, maintaining air and water quality, and odor management.
3. Hours of operation, and anticipated hours for truck deliveries and truck shipments.
4. Routing of trucks on the site, including truck stacking, parking and loading areas.
5. Protection measures proposed for any environmentally sensitive area located on the site, including any wellhead protection area.
6. Existing and proposed utilities.
7. Any other pertinent information to indicate clearly the orderly operation proposed.

24B-11(d) PLANNING COMMISSION MAY SEEK RECOMMENDATIONS - The Planning Commission may also refer any submitted development plan or Operational Plan to an appropriate public body (such as the Royal Spring Water Supply Protection Committee or the Paris Pike Corridor Commission) for their recommendations prior to the Commission's consideration of the request. In any event, that body must either make a recommendation to the Planning Commission within sixty (60) days of the date of submission, or abide by the Commission's decision.

24B-11(e) BUILDING PERMIT REQUIRED - No building permit shall be issued for buildings and structures in an AM-1 zone (not exempted from such requirements under Article 3-4 herein) until a final development plan has been approved by the Commission and certified to the Division of Planning, after which Building Inspection may issue a permit for construction. The approved final development plan shall limit and control the issuance of all required building and occupancy permits, and shall restrict the construction, location, and use of all land and structures to all conditions set forth in the plan. Amendments to the development plan can be made only as permitted in Article 21: Development Plans.

Section 13 - That this Ordinance shall become effective on the date of its passage.

PASSED URBAN COUNTY COUNCIL:

MAYOR

ATTEST:

Clerk of Urban County Council

PUBLISHED:

0892-17:TWJ:X:\CASES\PLANNING\17-LE0001\LEG\00584201.DOCX