



**CONTRACT DOCUMENTS
AND
SPECIFICATIONS**

DIVISION OF PARKS & RECREATION

FOR

**NEW CHAIN LINK DUGOUTS
VARIOUS LOCATIONS**

Bid No. 43-2013

PART 1

ADVERTISEMENT FOR BIDS

INDEX

1.	INVITATION	AB-1
2.	DESCRIPTION OF WORK	AB-1
3.	OBTAINING PLANS, SPECIFICATIONS, AND BID DOCUMENTS	AB-1
4.	METHOD OF RECEIVING BIDS	AB-2
5.	METHOD OF AWARD	AB-2
6.	BID WITHDRAWAL	AB-2
7.	BID SECURITY	AB-2
8.	SUBMISSION OF BIDS	AB-2
9.	RIGHT TO REJECT	AB-3
10.	NOTIFICATION TO THE LFUCG FOR AFFIRMATIVE ACTION	AB-3
11.	NOTICE CONCERNING DBE GOAL	AB-3
12.	PRE-BID MEETING	AB-4

ADVERTISEMENT FOR BIDS

1. INVITATION

Sealed proposals for the following work will be received by the Lexington-Fayette Urban County Government (LFUCG) until **2:00 p.m., local time, April 16, 2013**, for furnishing all labor and/or materials and performing all work as set forth by this advertisement, conditions (general and special), specifications, and/or the drawings prepared by and for Lexington-Fayette Urban County Government, Department of General Services. Immediately following the scheduled closing time for reception of bids, all proposals which have been submitted in accordance with the above will be publicly opened and read aloud.

2. DESCRIPTION OF WORK

The Division of Parks and Recreation will be demolishing several pairs of existing masonry dugouts at various locations in Lexington, KY. Bid is for the construction of new chain link dugouts to replace those demolished by Parks. Work shall also include related fence and gate repairs/replacements as noted or negotiated using unit prices and new/replacement asphalt and concrete as noted at each site. All work shall be per plans and specifications in accordance with the Contract Documents.

3. OBTAINING PLANS, SPECIFICATIONS, AND BID DOCUMENTS

Specifications, Plans, and Bid Documents may be examined on LFUCG's Economic Engine website and at the following places:

Lexington-Fayette Urban County Government
Division of Central Purchasing
200 East Main Street, Third Floor, Room 338
Lexington, Kentucky 40507
(859) 258-3320

4. METHOD OF RECEIVING BIDS

Bids will be received from Prime Contracting firms on a **Lump Sum Basis** for total Project. The Bidder must include a price for all bid items to be considered. Bids shall be submitted in the manner and subject to the conditions as set forth and described in the Instruction to Bidders and Special Conditions.

Sealed bids shall be clearly marked on the outside of the container as follows: Company Name and Address, Bid Invitation Number, and the Project Name. Bids are to remain sealed until official Bid closure time.

Mailed bids/proposals should be sent to the Director, Division of Central Purchasing, 200 East Main Street, Lexington, KY 40507.

5. METHOD OF AWARD

A. The Contract, if awarded, will be to the lowest, qualified responsible bidder for the total project whose qualifications indicate the award will be in the best interest of the OWNER and whose bid/proposal complies with all the prescribed requirements. No Notice of Award will be given until the OWNER has concluded such investigation as deemed necessary to establish the responsibility, qualifications and financial ability of Bidders to do the work in accordance with the Contract Documents to the satisfaction of the OWNER within the time prescribed. The OWNER reserves the right to reject the Bid of any Bidder who does not pass such investigation to the OWNER's satisfaction. In analyzing Bids, the OWNER may take into consideration alternate and unit prices, if requested by the Bid forms.

6. BID WITHDRAWAL

No bidder may withdraw his bid for a period of sixty (60) calendar days after the closing date for receipt of bids. Errors and omissions will not be cause for withdrawal of bid without forfeit of bid bond. Bids may be withdrawn in person prior to the closing date of receipt of bids.

7. BID SECURITY

If the bid is \$50,000 or greater, bid shall be accompanied by a certified check or bid bond payable to the Lexington-Fayette Urban County Government in an amount not less than Five Percent (5%) of the base bid. Bid bond shall be executed by a Surety Company authorized to do business in the Commonwealth of Kentucky and countersigned by a licensed Kentucky Resident Agent, representing the Surety Company. Bid Bonds are not required for bids under \$50,000. A cashier's check or irrevocable letter of credit is an acceptable form of bid security.

8. **SUBMISSION OF BIDS**

CONTRACTORS shall submit their bids to the Lexington-Fayette Urban County Government, Division of Purchasing, Third Floor, 200 East Main Street, Lexington, Kentucky 40507. Bids shall be submitted in a sealed envelope not later than **2:00 p.m. local time, April 16, 2013**. Sealed proposals shall be clearly marked on the outside of the container as follows: **“Company Name and Address, Bid Invitation Number, and Project Name to be opened at 2:00 p.m. local time, April 16, 2013**. Bids are to remain sealed until official Bid closure time. Bids received after the scheduled closing time for receipt of bids will not be considered and will be returned unopened.

9. **RIGHT TO REJECT**

The Lexington-Fayette Urban County Government reserves the right to reject any and all bids and to waive all informalities and/or technicalities where the best interest of the Lexington-Fayette Urban County Government may be served.

10. **NOTIFICATION TO THE LEXINGTON-FAYETTE URBAN COUNTY GOVERNMENT FOR AFFIRMATIVE ACTION PLAN AND CURRENT WORKFORCE**

The successful bidder must submit, within seven (7) calendar days of the bid opening, the following to the Lexington-Fayette Urban County Government:

1. Affirmative Action Plan for his/her firm.

Failure to submit this as required herein may result in disqualification of the Bidder from the award of the contract.

All submissions should be directed to:

Lexington-Fayette Urban County Government
Division of Purchasing
200 East Main Street, 3rd Floor, Room 338
Lexington, Kentucky 40507

11. **NOTICE CONCERNING DBE GOAL**

Notice of requirement for Affirmative Action to ensure Equal Employment Opportunities and Disadvantaged Business Enterprises (DBE) contract participation.

The Lexington-Fayette Urban County Government has set a goal that not less than ten percent (10%) of the total value of this contract be subcontracted to Disadvantaged Business Enterprises. The goal for the utilization of Disadvantaged Business Enterprises as subcontractors is a recommended goal. Contractors who fail to meet such goals will be expected to provide written explanations to the EEO Office and the Director of the Division of Purchasing of efforts they have made to accomplish the recommended goals, and the

extent to which they are successful in accomplishing the recommended goals will be a consideration in the procurement process.

For assistance in locating Disadvantaged Business Enterprises Subcontractors contact:

Marilyn Clark, Division of Central Purchasing
Lexington-Fayette Urban County Government
200 East Main Street, 3rd Floor, Room 338
Lexington, Kentucky 40507
(859) 258-3323

12. PRE-BID MEETING

No pre-bid meeting shall be scheduled. Bidders are encouraged to visit any or all sites with which they are unfamiliar prior to bidding. If a bidder has questions after examining any site, they should submit them through the Economic Engine website.

PART II
INFORMATION FOR BIDDERS

INDEX

1.	RECEIPT AND OPENING OF BIDS.....	IB-1
2.	PREPARATION OF BID	IB-1
3.	SUBCONTRACTS	IB-1
4.	QUALIFICATION OF BIDDER	IB-3
5.	BID SECURITY	IB-4
6.	LIQUIDATED DAMAGES FOR FAILURE TO ENTER INTO CONTRACT.....	IB-4
7.	TIME OF COMPLETION AND LIQUIDATED DAMAGES	IB-4
8.	EXAMINATION OF CONTRACT DOCUMENTS AND SITE	IB-5
9.	ADDENDA AND INTERPRETATIONS	IB-5
10.	SECURITY FOR FAITHFUL PERFORMANCE	IB-6
11.	POWER OF ATTORNEY	IB-6
12.	TAXES AND WORKMEN'S COMPENSATION	IB-6
13.	LAWS AND REGULATIONS	IB-6
14.	EROSION AND SEDIMENT CONTROL AND PERMITS	IB-6
15.	PREVAILING WAGE LAW AND MINIMUM HOURLY RATES	IB-7
16.	AFFIRMATIVE ACTION PLAN.....	IB-7
17.	CONTRACT TIME.....	IB-7
18.	SUBSTITUTION OR "OR-EQUAL" ITEMS.....	IB-7
19.	ALTERNATE BIDS	IB-8
20.	SIGNING OF AGREEMENT	IB-8
21.	ASSISTANCE TO BE OFFERED TO DBE CONTRACTORS.....	IB-8
22.	MBE/WBE PARTICIPATION GOALS	IB-10
23.	REQUIRED SUBMITTALS	IB-15

PART II

INFORMATION FOR BIDDERS

1. RECEIPT AND OPENING OF BIDS

The Lexington-Fayette Urban County Government (herein called the OWNER) invites bids from firms on the project described in the Advertisement for Bids. The OWNER will receive bids at the Division of Purchasing, at the time and in the manner set forth in the Advertisement for Bids, and the Bids will then be publicly opened and read aloud. The OWNER may consider informal any bid not prepared and submitted in accordance with the provisions hereof and may waive any informalities or reject any and all bids. Any bid may be withdrawn prior to the scheduled time for the opening of bids or authorized postponement thereof. Any bid received after the time and date specified shall not be considered. No bidder may withdraw a bid within 60 days after the actual time and date of the bid opening, but OWNER may, in its sole discretion, release any bid and return the Bid Security prior to that date.

The Lexington-Fayette Urban County Government assumes no responsibility for bids that are not addressed and delivered as indicated above. Bids that are not delivered to the Division of Central Purchasing by the stated time and date will be rejected.

2. PREPARATION OF BID

Each bid must be submitted on the prescribed Form of Proposal. All blank spaces for the bid prices must be filled in, either in ink or typewritten, for both unit prices and extensions. Totals for each bid item must be added to show the total amount of the bid. Each bid must be submitted in a sealed envelope bearing on the outside the name of the bidder, their address, the name of the project, the invitation number and time and date for which the bid is submitted. Bids must be addressed to the Director of Purchasing, Lexington-Fayette Urban County Government, Third Floor, 200 East Main Street, Lexington, Kentucky 40507. If forwarded by mail, the sealed envelope containing the bid must be enclosed in another envelope addressed as specified above.

3. SUBCONTRACTS

The bidder is specifically advised that any person, firm, or other party to whom it is proposed to award a subcontract under this Contract must be acceptable to the OWNER. All proposed subcontractors must be identified on the Form of Proposal. Prior to the award of Contract, the OWNER or the OWNER'S representative will advise the CONTRACTOR of the acceptance and approval thereof or of any action necessary to be taken. Should any Subcontractor be rejected by the OWNER, the CONTRACTOR shall present a new name and/or firm to the OWNER at no change in the Contract Price.

4. QUALIFICATION OF BIDDER

The OWNER may make such investigations as the OWNER deems necessary to determine the ability of the bidder to perform the Work, and the bidder shall furnish to the OWNER all such information and data for this purpose as the OWNER may request. The OWNER reserves the right to reject any bid if the evidence submitted by, or investigation of, such bidder fails to satisfy the OWNER that such bidder is properly qualified to carry out the obligations of the Contract and to complete the Work contemplated therein. Conditional bids will not be accepted.

In evaluating Bids, OWNER shall consider the qualifications of the BIDDERS, whether or not the Bids comply with the prescribed requirements, and alternatives and unit prices, as requested. OWNER may consider maintenance requirements, performance data, and disruption or damage to private property. It is OWNER'S intent to accept alternatives, if requested by the bid forms, in the order in which they are listed in the Bid Form but OWNER may accept or decline them in any order or combination. The contract, if awarded, will be awarded to the lowest, qualified, responsible BIDDER based upon OWNER'S evaluation which indicates that the award will be in the best interest of OWNER and the general public.

In the event there is any question as to the bidder's qualifications and ability to complete the work, a final determination will be made in accordance with a fair evaluation by the Urban County Government of the above listed elements.

- A. If the OWNER requires filling out a detailed financial statement, the bidder may provide its current certified financial statement(s) for the required time interval.
- B. Corporate firms are required to be registered and in good standing with the requirements and provisions of the Office of the Secretary of State, Commonwealth of Kentucky.
- C. Good standing with Public Works Act - any CONTRACTOR and/or subcontractors in violation of any wage or work act provisions (KRS 337.510 to KRS 337.550) are prohibited by Statutory Act (KRS 337.990) from bidding on or working on any and all public works contracts, either in their name or in the name of any other company, firm or other entity in which he might be interested. No bid from a prime contractor in violation of the Act can be considered, nor will any subcontractor in violation of the Act be approved and/or accepted. The responsibility for the qualifications of the subcontractor is solely that of the prime contractor.
- D. Documents Required of CONTRACTOR - (1) A sworn statement signed by the President or owner of the Company regarding all current work in progress anywhere; (2) A document showing the percent of completion of each project and the total worth of each project; and (3) Documentation showing the percentage of the DBE employment levels on each project of the Bidder's current work force, and DBE participation levels for Subcontractors.

- E. Optional OWNER Requirements - The OWNER, at its discretion, may require the BIDDER/CONTRACTOR to provide: (1) a current detailed financial statement for a period including up to 3 prior years; (2) financial security or insurance in amounts and kinds acceptable to the OWNER to meet the financial responsibility requirements for the CONTRACTOR to indemnify the OWNER. (3) Additional information and/or DBE work force data, as well as DBE participation data.

Each bidder agrees to waive any claim it has or may have against the Owner, the Architect/Engineer, and their respective employees, arising out of or in connection with the administration, evaluation, or recommendation of any bid.

5. BID SECURITY

- A. Each bid must be accompanied by a bid bond prepared on a Form of Bid Bond and attached hereto, duly executed by the bidder as principal and having as surety thereon a surety company approved by the OWNER, in the amount of 5% of the bid. Such bid bond will be returned to the unsuccessful bidder(s) only upon written request to the Director of Central Purchasing within seven (7) days of opening of bids. Bid bond shall be made payable to the Lexington-Fayette Urban County Government. Bid security is not required for projects under \$50,000.
- B. Bonds shall be placed with an agent licensed in Kentucky with surety authorized to do business within the state. When the premium is paid for such coverage, the full commission payable shall be paid to such local agent who shall not divide such commission with any person other than a duly licensed resident local agent.

6. LIQUIDATED DAMAGES FOR FAILURE TO ENTER INTO CONTRACT

The successful bidder, upon his failure or refusal to execute and deliver the Contract and bonds required within ten (10) days after he has received notice of the acceptance of his bid, shall forfeit to the OWNER, as liquidated damages for such failure or refusal, the security deposited with his bid.

7. TIME OF COMPLETION AND LIQUIDATED DAMAGES

Bidder must agree to commence work on or before a date to be specified in a written "Notice to Proceed" from the OWNER and to fully complete the Project within the time as specified in the Contract. Bidder must agree also to pay **\$200** per day as liquidated damages, or the sum as specified in the Contract for each consecutive calendar day thereafter as hereinafter provided in the General Conditions.

8. EXAMINATION OF CONTRACT DOCUMENTS AND SITE

- A. It is the responsibility of each Bidder before submitting a Bid, to (a) examine the Contract Documents thoroughly, (b) visit the site(s) to become familiar with local conditions that may affect cost, progress, performance or furnishing of the work, (c) consider Federal, State and Local laws and regulations that may affect cost, progress, performance or furnishing of the work, (d) study and carefully correlate Bidder's observations with the Contract Documents, and (e) notify Engineer of all conflicts, errors or discrepancies in the Contract Documents.
- B. Bidders should examine the requirements of section 4 of the General Conditions for information pertaining to subsurface conditions, underground structures, underground facilities, and availability of lands, easements, and rights-of-way. The completeness of data, presented in the Contract Documents, pertaining to subsurface conditions, underground structures, and underground facilities for the purposes of bidding or construction is not assured. The Bidder will, at Bidder's own expense, make or obtain any additional examinations, investigations, explorations, tests and studies and obtain any additional information and data which pertain to the physical conditions (surface and subsurface) which may affect cost, progress, performance or furnishing of the Work and which Bidder deems necessary to determine its Bid for performing and furnishing the Work in accordance with the time, price, and other terms and conditions of the Contract Documents. On request in advance, OWNER will provide access to the site to conduct such explorations and tests as each Bidder deems necessary for submission of a bid. Bidder shall fill all holes, clean up and restore the site to its former condition upon completion of such explorations.
- C. The submission of a Bid will constitute an incontrovertible representation by the Bidder that Bidder has complied with every requirement of this paragraph 8; that without exception the Bid is premised upon furnishing and performing the Work required by the Contract Documents and such means, methods, techniques, sequences or procedures of construction as may be indicated in or required by the Contract Documents; and that the Contract Documents are sufficient in scope and detail to indicate and convey understanding of all terms and conditions for performance and furnishing of the Work.

9. ADDENDA AND INTERPRETATIONS

No interpretation of the meaning of the Contract Documents will be made to any bidder orally. Every request for such interpretation should be in writing addressed to the Director of Central Purchasing, who in turn will have an addendum issued under signature of the Engineer for the Lexington-Fayette Urban County Government, and to be given consideration must be received at least seven (7) days prior to the date fixed for the opening of bids. Any and all such interpretations and any supplemental instructions will be in the form of written addenda to the specifications which, if issued, will be mailed by certified mail with return receipt requested or faxed to all prospective bidders. Failure of any bidder to receive any such addendum or interpretation shall not relieve such bidder from any obligation under his bid as submitted. All addenda so issued shall become part of the Contract Documents.

10. SECURITY FOR FAITHFUL PERFORMANCE

- A. Simultaneously with his delivery of the executed Contracts, the CONTRACTOR shall furnish a surety bond or bonds as security for the faithful performance of this Contract and for payment of all persons performing labor on the Project under this Contract and furnishing materials in connection with this Contract, as specified in the General Conditions. The surety on such bond or bonds shall be a duly authorized surety company satisfactory to the OWNER and authorized to do business in the Commonwealth of Kentucky.
- B. All bonds required by this Contract and laws of this State shall be placed with agents licensed in the State of Kentucky. When the premium is paid for such coverage's, the full commission shall be paid to such local agent who shall not divide such commission with any person other than a duly licensed resident local agent.
- C. **Contractor shall use standard Performance and Payment Bond forms such as documents provided with this contract book or AIA form A312-1984 (or later).**

11. POWER OF ATTORNEY

Attorney-in-fact who signs bid bonds or contract bonds must file with each bond a certified and effectively dated copy of their power of attorney.

12. TAXES AND WORKMEN'S COMPENSATION

The CONTRACTOR and subcontractor will be required to accept liability for payment of all payroll taxes, sales and use tax, and all other taxes or deductions required by local, state or federal law, such as old age pension, social security, or annuities measured by wages. Each shall carry Workmen's Compensation Insurance to the full amounts as required by Statutes and shall include the cost of all foregoing items in the proposal. The CONTRACTOR will not otherwise be reimbursed or compensated for such tax payments. The CONTRACTOR is urged to ascertain at his own risk his actual tax liability in connection with the execution or performance of his Contract.

13. LAWS AND REGULATIONS

The bidder's attention is directed to the fact that all applicable state laws, municipal ordinances, and the rules and regulations of all authorities having jurisdiction over construction of the Project shall apply to the Contract throughout, and they will be deemed to be included in the contract, the same as though herein written out in full.

14. EROSION AND SEDIMENT CONTROL AND PERMITS

The CONTRACTOR and Subcontractors performing work on projects on behalf of the OWNER shall also comply with all applicable federal, state, and local environmental regulations and all requirements and conditions set forth in "special" permits including but not limited to Corp of Engineers 404 permits, 401 Water Quality Certifications,

Stream Crossing and Floodplain Encroachment Permits as described in Part 4 General Conditions Paragraph 5.17.

15. PREVAILING WAGE LAW AND MINIMUM HOURLY RATES

Federal or state wage rates and regulations, if required for this Project, will be as described in the Special Conditions.

16. AFFIRMATIVE ACTION PLAN

The successful Bidder must submit with their bid, the following items to the Urban County Government:

1. Affirmative Action Plan for his/her firm – see Part II, page IB-7
2. Current Work Force Analysis Form – see Part III, page P-26
3. Good Faith Effort Documentation – see Part III, page P-18
4. List of Disadvantaged Business Enterprise Subcontractors and the Dollar Value of each Subcontract – see Part III, page 12

Bidders who frequently bid on Urban County Government projects may file a copy of their firm's Affirmative Action Plan with the Urban County Government. If an Affirmative Action Plan is filed with the Urban-County Government, additional submissions will not be required unless said plan is revised.

A Work Force Analysis Form shall be submitted for each Contract. Failure to submit these items as required herein may result in disqualification of the Bidder from award of the Contract.

All submissions should be directed to:

Director, Division of Central Purchasing
Lexington-Fayette Urban County Government
200 East Main Street, Third Floor
Lexington, KY 40507

17. CONTRACT TIME

The number of calendar days within which the Work is to be substantially completed and ready for final payment (the Contract Time) is set forth in the Form of Proposal and the Agreement.

18. SUBSTITUTE OR "OR-EQUAL" ITEMS

The Contract, if awarded, will be on the basis of materials and equipment described in the Drawings or specified in the Specifications without consideration of possible substitute or "or-equal" items. Whenever it is indicated in the Drawings or specified in the Specifications that a substitute or "or-equal" item of material or equipment may be furnished or used by the

CONTRACTOR if acceptable to the ENGINEER and OWNER, application for such acceptance will not be considered by the ENGINEER and OWNER until after the effective date of the Agreement. The procedure for submission of any such application by the CONTRACTOR and consideration by the ENGINEER and OWNER is set forth in the General Conditions.

19. ALTERNATE BIDS

Bidders shall submit alternate bids/proposals only if and when such alternate bids/proposals have been specifically requested in an Invitation for Bids. If alternate bids/proposals are requested in an Invitation for Bids, the form of submission of such alternate bid and the conditions under which such alternate bids will be considered for award of a contract will be established in the Invitation.

Any Bidder who submits a bid incorporating an alternate proposal when alternate bids/proposals have not been requested in the Invitation for Bids shall have his/her bid rejected as non-responsive.

Any Bidder who submits a bid incorporating two (2) or more prices for an item or groups of items (unless such method of pricing is requested in the Invitation for Bids), or which imposes conditions for acceptance other than those established in the Invitation for Bids, shall have their bid rejected as non-responsive.

20. SIGNING OF AGREEMENT

When OWNER gives a Notice of Award to the successful Bidder, it will be accompanied by the required number of unsigned counterparts of the Agreement with all other written Contract Documents attached. Within ten days thereafter, CONTRACTOR shall sign and deliver the required number of counterparts of the Agreement and attached documents to OWNER with the required Bonds, Certificate of Insurance, and Power of Attorney. The OWNER will deliver one fully signed counterpart to CONTRACTOR at such time as it has been signed by the Mayor.

21. ASSISTANCE TO BE OFFERED TO DISADVANTAGED BUSINESS ENTERPRISE (DBE) CONTRACTORS

I. Outreach

The Lexington-Fayette Urban County Government (LFUCG) maintains a mailing list of DBE contractors and organizations. When a LFUCG construction project is advertised for bidding, notices are sent to the entire mailing list. The notices describe the project, indicate the deadline for submitting bids, and review the bonding assistance which is available.

If you wish to be added to the LFUCG DBE contractor mailing list, please contact:

Marilyn Clark
Division of Central Purchasing

Lexington-Fayette Urban County Government
200 East Main Street, Room 338
Lexington, Kentucky 40507

II. Eligibility for Bid Bond Assistance

In order to be eligible for any bid bonding assistance, a DBE construction company must be owned or controlled at the level of 51% or more, by a member or members of a minority group or females. Prior to receiving assistance, a statement providing evidence of ownership and control of the company by a member or members of a minority group or females must be signed by the OWNER or corporate officer and by an attorney or accountant and submitted to:

Marilyn Clark
Division of Central Purchasing
Lexington-Fayette Urban County Government
200 East Main Street, Room 338
Lexington, Kentucky 40507

III. Subcontractors

The LFUCG will, upon request, assist prime contractors in the procurement of eligible DBE subcontractors in an effort to achieve the 10% minimum DBE goal.

For a list of eligible DBE subcontractors please contact:

Marilyn Clark
Division of Central Purchasing
Lexington-Fayette Urban County Government
200 East Main Street, Room 338
Lexington, Kentucky 40507

IV. Questions

If you have questions or wish to have additional information, please contact:

Sondra Stone, Buyer
Division of Central Purchasing
Lexington-Fayette Urban County Government
200 East Main Street, 3rd Floor
Lexington, Kentucky 40507
(859) 258-3320

22. MBE/WBE PARTICIPATION GOALS

A. GENERAL

- 1) The LFUCG request all potential contractors to make a concerted effort to include Minority-Owned (MBE) and Woman-Owned (WBE) Business Enterprises as subcontractors or suppliers in their bids.
- 2) Toward that end, the LFUCG has established 10% of total procurement costs as a Goal for participation of Minority-Owned and Woman-Owned Businesses on this contract.
- 3) **It is therefore a request of each Bidder to include in its bid, the same goal (10%) or for MBE/WBE participation and other requirements as outlined in this section.**

B. PROCEDURES

- 1) The successful bidder will be required to report to the LFUCG, the dollar amounts of all purchase orders submitted to Minority-Owned or Woman-Owned subcontractors and suppliers for work done or materials purchased for this contract. (See Subcontractor Monthly Payment Report)
- 2) Replacement of a Minority-Owned or Woman-Owned subcontractor or supplier listed in the original submittal must be requested in writing and must be accompanied by documentation of Good Faith Efforts to replace the subcontractor / supplier with another MBE/WBE Firm; this is subject to approval by the LFUCG. (See LFUCG MBE/WBE Substitution Form)
- 3) For assistance in identifying qualified, certified businesses to solicit for potential contracting opportunities, bidders may contact:
 - a) The Lexington-Fayette Urban County Government, Division of Central Purchasing (859-258-3320)
- 4) The LFUCG will make every effort to notify interested MBE/WBE subcontractors and suppliers of each Bid Package, including information on the scope of work, the pre-bid meeting time and location, the bid date, and all other pertinent information regarding the project.

C. DEFINITIONS

- 1) A Minority-Owned Business Enterprise (MBE) is defined as a business which is certified as being at least 51% owned and operated by persons of African American, Hispanic, Asian, Pacific Islander, American Indian or Alaskan Native Heritage.
- 2) A Woman-Owned Business Enterprise (WBE) is defined as a business which is certified as being at least 51% owned and operated by one or more Non-Minority Females.

D. OBLIGATION OF BIDDER

- 1) **The bidder shall make a Good Faith Effort to achieve the Participation Goal for MBE/WBE subcontractors/suppliers. The failure to meet the goal shall not necessarily be cause for disqualification of the bidder; however, bidders not meeting the goal are required to furnish with their bids written documentation of their Good Faith Efforts to do so.**
- 2) Award of Contract shall be conditioned upon satisfaction of the requirements set forth herein.
- 3) The Form of Proposal includes a section entitled "MBE/WBE Participation Form". The applicable information must be completed and submitted as outlined below.
- 4) **Failure to submit this information as requested will be cause for rejection of bid.**

E. DOCUMENTATION REQUIRED

- 1) Bidders reaching the Goal are required to submit only the "MBE/WBE Participation Form." The form must be fully completed including names and telephone number of participating MBE/WBE firm(s); type of work to be performed; estimated value of the contract and value expressed as a percentage of the total Lump Sum Bid Price. The form must be signed and dated, and is to be submitted with the bid.
- 2) Bidders not reaching the Goal must submit the "MBE/WBE Participation Form", the "MBE Quote Summary Form" and a written statement documenting their Good Faith Effort to do so (If bid includes no MBE/WBE participation, bidder shall enter "None" on the subcontractor / supplier form). In addition, the bidder may submit the following as proof of Good Faith Efforts to meet the Participation Goal:
 - a) Advertisement by the bidder of MBE/WBE Contracting opportunities associated with this bid in at least two (2) of the following:
 1. A periodical in general circulation throughout the region
 2. A Minority-Focused periodical in general circulation throughout the region
 3. A Trade periodical aimed at the MBE/WBE community in general circulation throughout the region
 4. Bidder shall include copies of dated advertisement with his submittal
 - b) Evidence of written notice of contracting opportunities to at least five (5) MBE/WBE firms serving the construction industry at least seven (7) days prior to the bid opening date.
 - c) Copies of quotations submitted by MBE/WBE firms which were not used due to uncompetitive pricing or other factors and/or copies of responses from firms that were contacted indicating that they would not be submitting a bid.

- d) Documentation of Bidder's utilization of the agencies identified to help locate potential MBE/WBE firms for inclusion on the contract including responses from agencies.
- e) Failure to submit any of the documentation requested in this section will be cause for rejection of bid. Bidders may include any other documentation deemed relevant to this requirement. "Record of MBE/WBE Solicitation" and other required documentation of Good Faith Efforts are to be submitted with the bid, if participation Goal is not met.



MINORITY BUSINESS ENTERPRISE PROGRAM

Marilyn Clark
Minority Business Enterprise Liaison
Division of Central Purchasing
Lexington-Fayette Urban County Government
200 East Main Street
Lexington, KY 40507
mclark@lexingtonky.gov
859-258-3323

OUR MISSION: The mission of the Minority Business Enterprise Program is to facilitate the full participation of minority and women owned businesses in the procurement process and to promote economic inclusion as a business imperative essential to the long term economic viability of Lexington-Fayette Urban County Government.

To that end the city council adopted and implemented resolution 167-91—Disadvantaged Business Enterprise (DBE) 10% Goal Plan in July of 1991. The resolution states in part (a full copy is available in Central Purchasing):

“A Resolution supporting adoption of the administrative plan for a ten percent (10%) Minimum goal for disadvantaged business enterprise participation in Lexington-Fayette Urban County Government construction and professional services contracts; Providing that as part of their bids on LFUCC construction contracts, general Contractors shall make a good faith effort to award at least ten percent (10%) of All subcontracts to disadvantaged business enterprises; providing that divisions of LFUCC shall make a good faith effort to award at least ten percent of their Professional services and other contracts to disadvantaged business enterprises...”

A Disadvantaged Business Enterprise is defined as a business at least 51% owned, operated and managed by a U.S. Citizen of the following groups:

- African-American
- Hispanic-American
- Asian/Pacific Islander
- Native American/Native Alaskan
- Non-Minority Female

We are very happy that you have decided to bid for a contract, request for proposal, submitted a quote or are interested in learning more about how to do business with Lexington-Fayette Urban County Government. We have compiled the list below to help you locate certified minority vendors.

LFUCG—Economic Engine Listings

Marilyn Clark
mclark@lexingtonky.gov
859-258-3323

Commerce Lexington—

Tyrone Tyra, Minority Business Development
tyra@commercelexington.com
859-226-1625

Tri-State Minority Supplier Diversity Council

Sonya Brown
sbrown@tsmsdc.com
502-625-0137

Small Business Development Council

Dee Dee Harbut /UK SBDC
ddharbut@uky.edu

Shawn Rogers, UK SBDC
Shawn.rogers@uky.edu

Shirce Mack
smack@uky.edu

Community Ventures Corporation

James Coles
jcoles@cvcky.org
859-231-0054

Kentucky Department of Transportation

Shella Jarvis
Shella.Jarvis@ky.gov
502-564-3601

KPAP

Debbie McKnight
Debbie.McKnight@ky.gov
800-838-3266 or 502-564-4252

Bobbie Carlton
Bobbie.Carlton@ky.gov

Ohio River Valley Women's Business Council

Rea Waldon
rwaldon@gcul.org
513-487-6534

Kentucky Small Business Connect

Tom Back
800-626-2250 or 502-564-2064
<https://secure.kentucky.gov//sbc>

**National Minority Supplier Development Council, Inc.
(NMSDC)**

www.nmsdc.org

23. REQUIRED SUBMITTALS

The following forms must be submitted with your bid at **minimum** or your bid will be considered non-responsive and rejected:

- Part III – Form of Proposal, P-2
 - Affidavit, P-5 (must be signed and notarized)
 - Bid Schedule, P-7 (original signature)
 - Statement of Qualifications, P-10
 - DBE Subcontractors, P-12
 - List of proposed subcontractors, P-13
 - Non-Collusion/Non-Conflict, P-19
 - Statement of Experience, P-20
 - EEO Agreement, P-22
 - EEO Affirmative Action Policy, P-25
 - Workforce Analysis, P-26
 - Evidence of Insurability Form, P-27 or Certificate of Insurance
 - Debarred Firms, P-28

PART III
FORM OF PROPOSAL

INDEX

1.	FORM OF PROPOSAL.....	P-2
2.	LEGAL STATUS OF BIDDER.....	P-4
3.	BIDDERS AFFIDAVIT	P-5
4.	BID SCHEDULE – SCHEDULE OF VALUES.....	P-7
5.	STATEMENT OF BIDDER'S QUALIFICATIONS.....	P-9
6.	LIST OF PROPOSED SUBCONTRACTORS	P-12
7.	MBE/WBE PARTICIPATION FORM	P-13
8.	MBE/WBE SUBSTITUTION FORM (only if awarded bid).....	P-14
9.	MBE QUOTE SUMMARY FORM.....	P-15
10.	SUBCONTRACTOR MONTHLY PAYMENT REPORT (only if awarded bid).....	P-16
11.	STATEMENT OF GOOD FAITH EFFORTS.....	P-17
12.	AUTHENTICATION OF BID AND STATEMENT OF NON-COLLUSION AND NON-CONFLICT OF INTEREST	P-18
13.	STATEMENT OF EXPERIENCE.....	P-19
14.	EQUAL OPPORTUNITY AGREEMENT	P-21
15.	EQUAL EMPLOYMENT OPPORTUNITY AFFIRMATIVE ACTION POLICY	P-24
16.	WORKFORCE ANALYSIS	P-25
17.	EVIDENCE OF INSURABILITY	P-26
18.	DEBARRED FIRMS	P-27
19.	DEBARRED CERTIFICATION	P-28

PART III

Invitation to Bid No. 43-2013

New Chain Link Dugouts – Various Locations

1. FORM OF PROPOSAL

Place: Lexington, Kentucky

Date: 04-08-2013

The following Form of Proposal shall be followed exactly in submitting a proposal for this Work.

This Proposal Submitted by Rio Grande Fence Company

137 S Forbes Rd. Lexington, Ky 40511
(Name and Address of Bidding Contractor)

(Hereinafter called "Bidder"), organized and existing under the laws of the State of Kentucky, doing business as a corporation
"a corporation," "a partnership", or an "individual" as applicable.

To: Lexington-Fayette Urban County Government
(Hereinafter called "OWNER")
Office of the Director of Purchasing
200 East Main Street, 3rd Floor
Lexington, KY 40507

Gentlemen:

The Bidder, in compliance with your Invitation for Bids for New Chain Link Dugouts having examined the Plans and Specifications with related documents, having examined the site for proposed Work, and being familiar with all of the conditions surrounding the construction of the proposed Project, including the availability of materials and labor, hereby proposes to furnish all labor, materials, and supplies, and to construct the Project in accordance with the Contract Documents, within the time set forth therein, and at the lump sum and/or unit prices stated hereinafter. These prices are to cover all expenses incurred in performing the Work required under the Contract Documents, of which this proposal is a part. The OWNER will issue work orders for work to be performed under this Contract.

BIDDER hereby agrees to commence work under this contract on or before a date to be specified in the Notice to Proceed and to fully complete the project within the time provided in the Purchase Order or Work Orders issued by the OWNER. BIDDER further agrees to pay liquidated damages, the sum of \$ 100 for each consecutive calendar day thereafter.

The Bidder hereby acknowledges receipt of the following addenda:

Addendum No. ____ Date _____

Addendum No. ____ Date _____

Addendum No. ____ Date _____

Addendum No. ____ Date _____

Addendum No. ____ Date _____

Addendum No. ____ Date _____

Addendum No. ____ Date _____

Addendum No. ____ Date _____

Insert above the number and the date of any Addendum issued and received. If none has been issued and received, the word "NONE" should be inserted.

2. LEGAL STATUS OF BIDDER

Bidder Bio Grande Fence Company

Date 04-08-2013

* 1. A corporation duly organized and doing business under the laws of the State of Kentucky, for whom Rhonda Gastre, bearing the official title of Secretary, whose signature is affixed to this Bid/Proposal, is duly authorized to execute contracts.

* 2. A Partnership, all of the members of which, with addresses are: (Designate general partners as such)

* 3. An individual, whose signature is affixed to this Bid/Proposal (please print name)

Mitch Blumenfeld

*(The Bidder shall fill out the appropriate form and strike out the other two.)

3. **BIDDERS AFFIDAVIT**

Comes the Affiant, Mitch Blumentfeld, and after being first duly sworn, states under penalty of perjury as follows:

1. His/her name is Mitch Blumentfeld and he/she is the individual submitting the bid or is the authorized representative of RIO GRANDE FENCE CO, the entity submitting the bid (hereinafter referred to as "Bidder").
 2. Bidder will pay all taxes and fees, which are owed to the Lexington-Fayette Urban County Government at the time the bid is submitted, prior to award of the contract and will maintain a "current" status in regard to those taxes and fees during the life of the contract.
 3. Bidder will obtain a Lexington-Fayette Urban County Government business license, if applicable, prior to award of the contract.
 4. Bidder has authorized the Division of Central Purchasing to verify the above-mentioned information with the Division of Revenue and to disclose to the Urban County Council that taxes and/or fees are delinquent or that a business license has not been obtained.
 5. Bidder has not knowingly violated any provision of the campaign finance laws of the Commonwealth of Kentucky within the past five (5) years and the award of a contract to the Bidder will not violate any provision of the campaign finance laws of the Commonwealth.
 6. Bidder has not knowingly violated any provision of Chapter 25 of the Lexington-Fayette Urban County Government Code of Ordinances, known as the "Ethics Act."
 7. Bidder acknowledges that "knowingly" for purposes of this Affidavit means, with respect to conduct or to circumstances described by a statute or ordinance defining an offense, that a person is aware or should have been aware that his conduct is of that nature or that the circumstance exists.
- Further, Affiant sayeth naught.

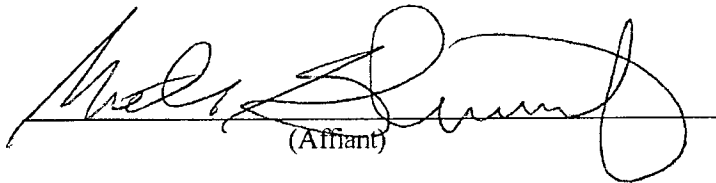
(Affiant)

STATE OF Kentucky

COUNTY OF Fayette

The foregoing instrument was subscribed, sworn to and acknowledged before me by

Mitch Blumenfeld on this the 8 day of April,
2013.

My Commission expires: 5/6/13

Rhonda Hastineau
NOTARY PUBLIC, STATE AT LARGE

4. **BID SCHEDULE – SCHEDULE OF VALUES**

The Bidder agrees to perform all the Work described in the Specifications and shown on the Plans for the following lump sum and/or unit prices, if applicable, which shall include the furnishing of all labor, materials, supplies, equipment and/or vehicle usage, services, all items of cost, overhead, taxes (federal, state, local), and profit for the CONTRACTOR and any Subcontractor involved, within the time set forth herein.

Bidder shall be selected based on the greatest number of locations that can be afforded within the project budget. If more than one bidder offers the same number of locations for under the project budget, selection will be based on the lowest total cumulative bid up to but not to exceed \$100,000.

If unit prices are applicable, Bidder must make the extensions and additions showing the total amount of bid. The estimated quantities of items of unit price work are not guaranteed and are solely for the purpose of comparison of bids and determining an initial Contract price. Determination of the actual quantities and classification of unit price work performed by the Contractor will be made by the Landscape Architect in accordance with the General Conditions.

In case of discrepancy, the amount shown in words will govern.

Item No.	Description w/Unit Bid Price Written in Words	Estimated Quantity	Unit	Unit Price	Total Bid Amount
1.	<p>Base Bid #1 - Castlewood Park Baseball Field Provide all labor, tools, equipment and materials to construct a new pair of 30 ft x 10 ft galvanized chain link dugouts with new concrete pad, new team benches and associated new concrete sidewalk in accordance with the Contract Documents</p> <p><u>thirty two thousand eight hundred ninety one</u> Dollars and <u>zero</u> Cents (Lump Sum)</p>	1	LS	\$ _____	<u>\$32,891</u>
2.	<p>Add Alternate #1 Castlewood Park Softball Field Provide all labor, tools, equipment and materials to construct a new pair of 20 ft x 10 ft galvanized chain link dugouts with new concrete pad, new team benches and associated new concrete pavement in accordance with the Contract Documents</p> <p><u>twenty six thousand four hundred twenty one</u> Dollars <u>zero</u> Cents (Lump Sum)</p>	1	LS	\$ _____	<u>\$26,420</u>

3.	<p>Add Alternate #2 Woodland Park Softball Field Provide all labor, tools, equipment and materials to construct a new pair of 20 ft x 10 ft galvanized chain link dugouts with new concrete pad with front header curb and new team benches in accordance with the Contract Documents</p> <p><u>twenty-five thousand two hundred and twenty</u> Dollars <u>zero</u> Cents (Lump Sum)</p>	1	LS	\$ _____	<u>\$25,220</u>
4.	<p>Add Alternate #3 Kirklevington Park Provide all labor, tools, equipment and materials to construct a new pair of 30 ft x 10 ft galvanized chain link dugouts, new 5 ft wide gates, new team benches and associated new concrete sidewalk in accordance with the Contract Documents</p> <p><u>thirty one thousand six hundred</u> Dollars <u>zero</u> Cents (Lump Sum)</p>	1	LS	\$ _____	<u>\$31,600</u>
5.	<p>Add Alternate #4 Southland Park Baseball Field Provide all labor, tools, equipment and materials to construct a new pair of 30 ft x 10 ft galvanized chain link dugouts, new team benches, new 4' wide gates, new 5' x 10' concrete walk and 10' x 10' asphalt patch in accordance with the Contract Documents</p> <p><u>thirty-two thousand seven hundred</u> Dollars <u>zero</u> Cents (Lump Sum)</p>	1	LS	\$ _____	<u>\$32,700</u>

6.	<p>Add Alternate #5 Southland Park T-Ball Field Provide all labor, tools, equipment and materials to construct a new pair of 20 ft x 10 ft galvanized chain link dugouts, new team benches, new 4' wide gates, remove sections of 10' tall fence & replace to match existing outfield fence and patch existing asphalt where existing dugouts have been removed (2 areas approx 8' x 20' each) in accordance with the Contract Documents</p> <p><u>Twenty six thousand three hundred</u> Dollars <u>Fifty</u> <u>zero</u> Cents (Lump Sum)</p>	1	LS	\$ _____	\$ <u>26,350</u>
7.	<p>Additive Alternate #6 Wolf Run Park Provide all labor, tools, equipment and materials to construct a new pair of 30 ft x 10 ft galvanized chain link dugouts with new concrete pad and new team benches in accordance with the Contract Documents</p> <p><u>Thirty two thousand seven hundred</u> Dollars _____ Cents (Lump Sum)</p>	1	LS	\$ _____	\$ <u>32,700</u>

LIST OF UNIT PRICES

The following List of Unit Prices is required by the Owner to be completely executed and submitted with each Bidder's Proposal. Each unit price shall include the furnishing of all labor, materials, supplies and services, and shall include all items of cost, overhead and profit for the Contractor and any Sub-Contractors involved, and shall be used uniformly, without modification, for either additions or deductions from the Bid. These unit prices as established shall also be used to determine the equitable adjustment of the Contract Price in connection with changes, or extra work performed under the Contract. The "Rules of Measurement" set forth in the Special Conditions shall govern where volume units are concerned.

DESCRIPTION OF WORK	UNIT PRICE	
1. Asphalt paving patch, Class 1 base	<u>225.00</u>	TN
2. Asphalt paving patch, Class 1 surface	<u>225.00</u>	TN
3. 4.5" 4000psi Concrete pavement over 3" #57 stone	<u>27.00</u>	SY
4. 4" 4000psi Concrete pavement over 6" DGA	<u>27.00</u>	SY
5. Standard concrete header curb (LFUCG drawing # 302)	<u>15.00</u>	LF
6. Excavation/Grading (using onsite material)	<u>75.00</u>	CY
7. Top Soil delivered and placed on site	<u>275.00</u>	CY
8. Seed & cover	<u>2.75</u>	SY
9. #57 crushed stone, brought to site and placed	<u>85.00</u>	TN
10. Dense grade aggregate, brought to site and placed	<u>85.00</u>	TN
11. Rock removal (Highly weathered, broken limestone that can be effectively excavated with normal earth trenching equipment will NOT be classified as rock removal)	<u>300.00</u>	CY
12. Replace existing galvanized fence (fabric only) – 10 ft height	<u>26.00</u>	LF
13. Replace existing galvanized fence (fabric only) – 8 ft height	<u>22.00</u>	LF
14. Replace existing galvanized fence (fabric only) – 6 ft height	<u>21.00</u>	LF
15. Replace existing galvanized fence (fabric only) – 5 ft height	<u>19.00</u>	LF
16. Replace existing galvanized fence (fabric only) – 4 ft height	<u>18.00</u>	LF

Submitted by:

Bio Grande Fence Company
Firm

137 S Forbes Rd
Address

Lexington, KY 40511
City, State & Zip

**Bid must be signed:
(original signature)**

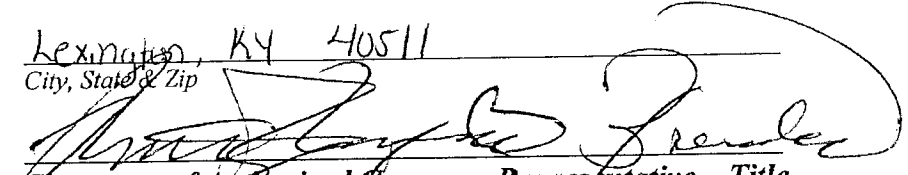
Signature of Authorized Company Representative - Title

Mitch Blumenfeld
Representative/s Name (Typed or Printed)

859-263-7944
Area Code - Phone - Extension

859-263-7454
Fax #

Mitch@biograndefence.com
E-Mail Address

OFFICIAL ADDRESS:

137 South Forbes rd
Lexington, KY 40511

(Seal if Bid is by Corporation)

By signing this form you agree to ALL terms, conditions, and associated forms in this bid package

5. STATEMENT OF BIDDER'S QUALIFICATIONS

The following statement of the Bidder's qualifications is required to be filled in, executed, and submitted with the Proposal:

1. Name of Bidder: Rio Grande Fence Company
2. Permanent Place of Business: 137 S Forbes Rd. Lexington, Ky 40511
3. When Organized: 1960
4. Where Incorporated: Kentucky
5. Construction Plant and Equipment Available for this Project:

(Attach Separate Sheet If Necessary)

6. Financial Condition:

If specifically requested by the OWNER, the apparent low Bidder is required to submit its latest three (3) years audited financial statements to the OWNER'S Division of Central Purchasing within seven (7) calendar days following the bid opening.

7. In the event the Contract is awarded to the undersigned, surety bonds will be furnished by:

The Ohio Casualty Insurance Company (Surety)

Signed: [Signature] (Representative of Surety)

8. Contractors who wish to submit bids for this project must have successfully completed at least 10 commercial fencing projects each year for the last three (3) years.

The following is a list of similar or other commercial projects performed by the General Contractor in the last calendar year (additional projects shall be provided if requested during bid evaluation):

PROJECT NAME	LOCATION	CONTRACT SUM	DATE COMPLETED
1. Fed Ex	Parkburg	150,000	7-01-12
2. Fed Ex	Harcl.	165,000	8-1-2012
3. Fed Ex	North Ky.	145,000	2-12-2012
4. Waltham	Burgin	459,000	6-6-2012
5. Hawkislow	Bryn	220,000	1-22-2013
6.			
7.			
8.			
9.			
10.			

9. The Bidder has now under contract and bonded the following projects:

<u>NAME</u>	<u>LOCATION</u>	<u>CONTRACT SUM</u>
Scott County	George Twp.	129,000 ^{xy}

10. List Key Bidder Personnel who will work on this Project.

<u>NAME</u>	<u>POSITION DESCRIPTION</u>	<u>NO. OF YEARS WITH BIDDER</u>
Tina Lees	Team lead	7 years
Mitch Bobb	Owner	30 years

11. DBE Participation on current bonded projects under contract:

<u>SUBCONTRACTORS (LIST)</u>	<u>PROJECT (SPECIFIC TYPE)</u>	<u>DBE</u>	<u>% of WORK</u>

(USE ADDITIONAL SHEETS IF NECESSARY)

12. We acknowledge that, if we are the apparent low Bidder, we will submit to the OWNER within 7 calendar days following the Bid Opening, a sworn statement on the OWNER'S form regarding all current work on hand and under contract, and a statement on the OWNER'S form of the experience of our officers, office management and field management personnel. Additionally, if requested by the OWNER, we will within 7 days following the request submit audited financial statements and loss history for insurance claims for the 3 most recent years (or a lesser period stipulated by the OWNER)—all in accordance with the Bid Documents.

6. LIST OF PROPOSED SUBCONTRACTORS

The following list of proposed subcontractors is required by the OWNER to be executed, completed and submitted with the BIDDER'S FORM OF PROPOSAL. All subcontractors are subject to approval of the Lexington-Fayette Urban County Government. Failure to submit this list completely filled out may be cause for rejection of bid.

<u>BRANCH OF WORK - LIST EACH MAJOR ITEM</u> Such as: Grading, bituminous paving, concrete, seeding and protection, construction staking, etc.	<u>SUBCONTRACTOR</u>	<u>DBE</u> <u>Yes/No</u>	% of Work
1. <u>ZKB Services</u> <u>Concrete</u>	Name: <u>ZKB Services</u> Address: <u>115 MACArthur Ct.</u>		
2. <u>Seed</u>	Name: <u>Cedar Valley</u> Address: <u>Sussex Belmont</u>		
3. _____	Name: _____ Address: _____		
4. _____	Name: _____ Address: _____		
5. _____	Name: _____ Address: _____		
6. _____	Name: _____ Address: _____		
7. _____	Name: _____ Address: _____		

(Attach additional sheet(s) if necessary.)



7. **LFUCG MBE/WBE PARTICIPATION FORM**

Bid/RFP/Quote Reference # 43-2013

The MBE/WBE subcontractors listed have agreed to participate on this Bid/RFP/Quote. If any substitution is made or the total value of the work is changed prior to or after the job is in progress, it is understood that those substitutions must be submitted to Central Purchasing for approval immediately.

MBE/WBE Company, Name, Address, Phone, Email	Work to be Performed	Total Dollar Value of the Work	% Value of Total Contract
1.			
2.			
3.			
4.			

The undersigned company representative submits the above list of MBE/WBE firms to be used in accomplishing the work contained in this Bid/RFP/Quote. Any misrepresentation may result in the termination of the contract and/or be subject to applicable Federal and State laws concerning false statements and false claims.

Rio Grande Fence Company
Company

Company Representative

4/8/13
Date

President
Title



8. **LFUCG MBE/WBE SUBSTITUTION FORM**

Bid/RFP/Quote Reference # 43-2013

The substituted MBE/WBE subcontractors listed below have agreed to participate on this Bid/RFP/Quote. These substitutions were made prior to or after the job was in progress. These substitutions were made for reasons stated below and are now being submitted to Central Purchasing for approval. By the authorized signature of a representative of our company, we understand that this information will be entered into our file for this project.

SUBSTITUTED MBE/WBE Company Name, Address, Phone, Email	MBE/WBE Formally Contracted/ Name, Address, Phone, Email	Work to Be Performed	Reason for the Substitution	Total Dollar Value of the Work	% Value of Total Contract
1.					
2.					
3.					
4.					

The undersigned acknowledges that any misrepresentation may result in termination of the contract and/or be subject to applicable Federal and State laws concerning false statements and false claims.

Rio Grande Fence Company
Company

Company Representative

Date

Title



9. MBE/WBE QUOTE SUMMARY FORM

Bid/RFP/Quote Reference # 43-2013

The undersigned acknowledges that the minority subcontractors listed on this form did submit a quote to participate on this project.

Company Name <u>Rio Grande Fence Company</u>	Contact Person <u>Mitch Babbs</u>
Address/Phone/Email <u>137 S Forbes Rd Lexington, KY 40511 859-263-7944 mitch@riograndefence.com</u>	Bid Package / Bid Date

MBE/WBE Company Address	Contact Person	Contact Information (work phone, Email, cell)	Date Contacted	Services to be performed	Method of Communication (email, phone meeting, ad, event etc)	Total dollars \$\$ Do Not Leave Blank (Attach Documentation)	MBE * AA HA AS NA Female

(MBE designation / AA=African American / HA= Hispanic American/AS = Asian American/Pacific Islander/ NA= Native American)

The undersigned acknowledges that all information is accurate. Any misrepresentation may result in termination of the contract and/or be subject to applicable Federal and State laws concerning false statements and claims.

Rio Grande Fence Company
Company

Company Representative

Date

Title



10. LFUCG MBE/WBE SUBCONTRACTOR MONTHLY PAYMENT REPORT

The LFUCG has a 10% goal plan adopted by city council to increase the participation of minority and women owned businesses in the procurement process. In order to measure that goal LFUCG will track spending with MBE/WBE vendors on a monthly basis. By the signature below of an authorized company representative, you certify that the information is correct, and that each of the representations set forth below is true. Any misrepresentation may result in termination of the contract and/or prosecution under applicable Federal and State laws concerning false statements and false claims. Please submit this form monthly to the Division of Central Purchasing/ 200 East Main Street / Room 338 / Lexington, KY 40507.

Bid/RFP/Quote # 43-2013
 Total Contract Amount Awarded to Prime Contractor for this Project _____

Project Name/ Contract #	Work Period/ From: _____ To: _____
Company Name:	Address: _____
Federal Tax ID:	Contact Person: _____

Subcontractor Vendor ID (name, address, phone, email)	Description of Work	Total Subcontract Amount	% of Total Contract Awarded to Prime for this Project	Total Amount Paid for this Period	Purchase Order number for subcontractor work (please attach PO)	Scheduled Project Start Date	Scheduled Project End Date

By the signature below of an authorized company representative, you certify that the information is correct, and that each of the representations set forth below is true. Any misrepresentations may result in the termination of the contract and/or prosecution under applicable Federal and State laws concerning false statements and false claims.

 Company

 Company Representative

 Date

 Title



11. LFUCG STATEMENT OF GOOD FAITH EFFORTS

Bid/RFP/Quote # 43-2013

By the signature below of an authorized company representative, we certify that we have utilized the following methods to obtain the maximum practicable participation by minority and women owned business enterprises on the project. Please indicate which methods you used by placing an X in the appropriate place.

- Attended LFUCG Central Purchasing Economic Inclusion Outreach Event
- Sponsored Economic Inclusion event to provide networking opportunities
- Requested a list of MBE/WBE subcontractors or suppliers from LFUCG Economic Engine
- Advertised for MBE/WBE subcontractors or suppliers in local or regional newspapers
- Showed evidence of written notice of contracting and/or supplier opportunities to MBE/WBE firms at least seven days prior to the bid opening date
- Provided copies of quotations submitted by MBE/WBE firms which were not used and/or responses from firms indicating they would not be submitting a quote
- Provided plans, specifications, and requirements to interested MBE/WBE subcontractors
- Other
Please list any other methods utilized that aren't covered above.

The undersigned acknowledges that all information is accurate. Any misrepresentations may result termination of the contract and/or be subject to applicable Federal and State laws concerning false statements and claims.

Rio Grande Fence Company
Company

Mitch Blumenfeld
Company Representative

4/5/13
Date

President
Title

12. AUTHENTICATION OF BID AND STATEMENT OF NON-COLLUSION, NON-CONFLICT OF INTEREST

I hereby swear (or affirm) under the penalty for false swearing:

1. That I am the Bidder (if the Bidder is an individual), a partner of the Bidder (if the Bidder is a partnership), or an officer or employee of the bidding corporation having authority to sign on its behalf (if the Bidder is a corporation);
2. That the attached bid has been arrived at by the Bidder independently, and has been submitted without collusion with, and without any agreement, understanding or planned common course of action, with any other contractor, vendor of materials, supplies, equipment or services described in the Invitation to Bid, designed to limit independent bidding or competition;
3. That the contents of the bid or bids have not been communicated by the Bidder or its employees or agents to any person not an employee or agent of the Bidder or its surety on any bond furnished, with the bid or bids, and will not be communicated to any such person, prior to the official opening of the bid or bids;
4. That the Bidder is legally entitled to enter into the contracts with the Lexington-Fayette Urban County Government, and is not in violation of any prohibited conflict of interest;
5. (Applicable to corporation only) That as a foreign corporation, we are registered with the Secretary of State, Commonwealth of Kentucky, and authorized to do business in the State _____ or, that as a domestic corporation, we are in good standing with the Secretary of State, Commonwealth of Kentucky . Check the statement applicable.
6. This offer is for 60 calendar days from the date this bid is opened. In submitting the above, it is expressly agreed that, upon proper acceptance by the Lexington-Fayette Urban County Government of any or all items bid above, a contract shall thereby be created with respect to the items accepted.
7. That I have fully informed myself regarding the accuracy of the statements made in this statement.
8. That I certify that Subcontractors have not and will not be awarded to any firm(s) that have been debarred from noncompliance with the Federal Labor Standards, Title VI of the Civil Rights Act of 1964 As Amended, Executive Order 11246 As Amended or any other Federal Law.

13. STATEMENT OF EXPERIENCE

NAME OF INDIVIDUAL: Mitch Blumenfeld

POSITION/TITLE: President

STATEMENT OF EXPERIENCE: 30 years fence installation

NAME OF INDIVIDUAL: _____

POSITION/TITLE: _____

STATEMENT OF EXPERIENCE: _____

NAME OF INDIVIDUAL: _____

POSITION/TITLE: _____

STATEMENT OF EXPERIENCE: _____

NAME OF INDIVIDUAL: _____

POSITION/TITLE: _____

STATEMENT OF EXPERIENCE: _____

NAME OF INDIVIDUAL: _____

POSITION/TITLE: _____

STATEMENT OF EXPERIENCE: _____

NAME OF INDIVIDUAL: _____

POSITION/TITLE: _____

STATEMENT OF EXPERIENCE: _____

* Include all officers, office management's, Affirmative Action officials, and field management personnel. (Attach separate sheets if necessary.)

14. EQUAL OPPORTUNITY AGREEMENT

The Law

- * Title VII of the Civil Rights Act of 1964 (amended 1972) states that it is unlawful for an employer to discriminate in employment because of race, color, religion, sex, age (40-70 years) or national origin.
- * Executive Order No. 11246 on Nondiscrimination under Federal contract prohibits employment discrimination by contractor and subcontractor doing business with the Federal Government or recipients of Federal funds. This order was later amended by Executive Order No. 11375 to prohibit discrimination on the basis of sex.
- * Section 503 of the Rehabilitation Act of 1973 States:
The Contractor will not discriminate against any employee or applicant for employment because of physical or mental handicap.
- * Section 2012 of the Vietnam Era Veterans Readjustment Act of 1973 requires Affirmative Action on behalf of disabled veterans and veterans of the Vietnam Era by contractors having Federal Contracts.
- * Section 206 (A) of Executive Order 12086, Consolidation of Contract Compliance Functions for Equal Employment Opportunity, states:
The Secretary of Labor may investigate the employment practices of any Government contractor or sub-contractor to determine whether or not the contractual provisions specified in Section 202 of this order have been violated.

The Lexington-Fayette Urban County Government practices Equal Opportunity in recruiting, hiring and promoting. It is the Government's intent to affirmatively provide employment opportunities for those individuals who have previously not been allowed to enter into the mainstream of society. Because of its importance to the local Government, this policy carries the full endorsement of the Mayor, Commissioners, Directors, and all supervisory personnel. In following this commitment to Equal Employment Opportunity and because the Government is the benefactor of the Federal funds, it is both against the Urban County Government policy and illegal for the Government to let contracts to companies which knowingly or unknowingly practice discrimination in their employment practices. Violation of the above mentioned ordinances may cause a contract to be canceled and the contractor may be declared ineligible for future consideration.

Please sign this statement in the appropriate space acknowledging that you have read and understand the provisions contained herein. Return this document as part of your application packet.

Bidders

I/We agree to comply with the Civil Rights Laws listed above that govern employment rights of minorities, women, Vietnam veterans, handicapped, and aged persons.

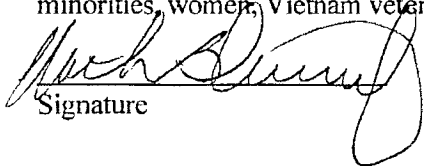
Signature

Rio Grande Fence Company
Name of Business

The Entity (regardless of whether construction contractor, non-construction contractor or supplier) agrees to provide equal opportunity in employment for all qualified persons, to prohibit discrimination in employment because of race, color, creed, national origin, sex or age, and to promote equal employment through a positive, continuing program from itself and each of its sub-contracting agents. This program of equal employment opportunity shall apply to every aspect of its employment policies and practices.

The Kentucky equal Employment Opportunity Act of 1978 (KRS 45.560-45.640) requires that any count, city, town, school district, water district, hospital district, or other political subdivision of the state shall include in directly or indirectly publicly funded contracts for supplies, materials, services, or equipment hereinafter entered into the following provisions:

During the performance of this contract, the contractor agrees as follows:

- (1) *The contractor will not discriminate against any employee or applicant for employment because of race, color, religion, sex, age or national origin;*
- (2) *The contractor will state in all solicitations or advertisements for employees placed by or on behalf of the contractors that all qualified applicants will receive consideration for employment without regard to race, color, religion, sex, age or national origin;*
- (3) *The contract will post notices in conspicuous places, available to employees and applicants for employment, setting forth the provisions of the non-discrimination clauses required by this section; and*
- (4) *The contractor will send a notice to each labor union or representative of workers with which he has a collective bargaining agreement or other contract or understanding advising the labor union or workers' representative of the contractor's commitments under the nondiscrimination clauses.*

The Act further provides:

KRS 45.610. Hiring minorities – Information required

- (1) *For the length of the contract, each contractor shall hire minorities from other sources within the drawing area, should the union with which he has collective bargaining agreements be unwilling to supply sufficient minorities to satisfy the agreed upon goals and timetable.*
- (2) *Each contractor shall, for the length of the contract, furnish such information as required by KRS 45.560 to KRS 45.640 and by such rules, regulations and orders issued pursuant thereto and will permit access to all books and records pertaining to his employment practices and work sites by the contracting agency and the department for purposes of investigation to ascertain compliance with KRS 45.560 to 45.640 and such rules, regulations and orders issued pursuant thereto.*

KRS 45.620. Action against contractor – Hiring of minority contractor or subcontractor

- (1) *If any contractor is found by the department to have engaged in an unlawful practice under this chapter during the course of performing under a contract or subcontract covered under KRS 45.560 to 45.640, the department shall so certify to the contracting agency and such certification shall be binding upon the contracting agency unless it is reversed in the course of judicial review.*
- (2) *If the contractor is found to have committed an unlawful practice under KRS 45.560 to 45.640, the contracting agency may cancel or terminate the contract, conditioned upon a program for future compliance approved by the contracting agency and the department. The contracting agency may declare such a contractor ineligible to bid on further contracts with that agency until such time as the contractor complies in full with the requirements of KRS 45.560 – 45.640.*
- (3) *The equal employment provisions of KRS 45.560 to 45.640 may be met in part by a contractor by subcontracting to a minority contractor or subcontractor. For the provisions of KRS 45.560 to 45.640, a minority contractor or subcontractor shall mean a business that is owned and controlled by one or more persons disadvantaged by racial or ethnic circumstances.*

KRS 45.630 Termination of existing employee not required, when

Any provision of KRS 45.560 to 45.640 notwithstanding, no contractor shall be required to terminate an existing employee upon proof that that employee was employed prior to the date of the contract.

KRS 45.640 Minimum skills

Nothing in KRS 45.560 to 45.640 shall require a contractor to hire anyone who fails to demonstrate the minimum skills required to perform a particular job.

It is recommended that all of the provisions quoted above to be included as special conditions in each contract. In the case of a contract exceeding \$250,000, the contractor is required to furnish evidence that his work-force in Kentucky is representative of the available work-force in the area from which he draws employees, or to supply an Affirmative Action plan which will achieve such representation during the life of the contract.

15. EQUAL EMPLOYMENT OPPORTUNITY AFFIRMATIVE ACTION POLICY

It is the policy of Rio Grande Fence Co., Inc

to assure that all applicants for employment and all employees are treated on a fair and equitable basis without regard to their race, religion, sex, color, handicap, natural origin or age.

Such action shall include employment, promotion, demotion, recruitment or recruitment advertising, layoff or termination, rates of pay and other forms of compensation, and selection for training, whether apprenticeship and/or on-the-job-training.

Furthermore, this company agrees to make special recruitment efforts to hire the protected class whenever feasible. This company also agrees to adhere to all applicable federal, state, and local laws relating to Equal Employment Opportunity for all individuals.

16. WORKFORCE ANALYSIS FORM

Name of Organization: Rio Grande Fence Date: 4 / 8 / 13

Categories	Total	White		Black		Other		Total
		M	F	M	F	M	F	
Administrators	1	1						1
Professionals								
Superintendents								
Supervisors	1	1						1
Foremen	3	3						3
Technicians	3	3						3
Protective Service								
Para-Professionals								
Office/Clerical	5	2	3					2 3
Skilled Craft								
Service/Maintenance								
Total:								

Prepared By: Chonda Baker

17. **EVIDENCE OF INSURABILITY**

LEXINGTON-FAYETTE URBAN COUNTY GOVERNMENT CONSTRUCTION PROJECT
(Use separate form for each Agency or Brokerage agreeing to provide coverage)

Names Insured: Rio Grande fence

Employee ID: _____

Address: 137 S Forbes Rd Lexington, Ky

Phone: 859 263 7974

Project to be insured: New Chainlink Fences (Fence)

In lieu of obtaining certificates of insurance at this time, the undersigned agrees to provide the above Named Insured with the minimum coverage listed below. These are outlined in the Insurance and Risk Management of Part V (Special Conditions), including all requirements, and conditions:

Section Items	Coverage	Minimum Limits and Policy Requirements	Limits Provided To Insured	Name of Insurer	A.M. Best's Code	Rating
SC-3, Section 2, Part 4.1 - see provisions	CGL	\$1,000,000 per occ. And \$2,000,000 aggregate	\$1,000,000 2,000,000	Motorist		
SC-3, Section 2, Part 4.1 - see provisions	AUTO	\$2,000,000/per occ.	\$1,000,000 2,000,000 um	Motorist		
SC-3, Section 2, Part 4.1 - see provisions	WC	Statutory w/endorsement as noted	\$4,000,000	KY AGL		

Section 2 includes required provisions, statements regarding insurance requirements, and the undersigned agrees to abide by all provisions for the coverage's checked above unless stated otherwise when submitting.

Agency or Brokerage Carroll Insurance Co.

Name of Authorized Representative _____

Street Address _____
City Lex State Ky Zip _____
Telephone Number 859-269-1044

Title _____
Authorized Signature [Signature]
Date 4-08-2013

NOTE: Authorized signatures may be the agent's if agent has placed insurance through an agency agreement with the insurer. If insurance is brokered, authorized signature must be that of authorized representative of insurer.

18. DEBARRED FIRMS

PROJECT NAME: New Chamlink Dugouts

BID NUMBER: 43-2013

LEXINGTON-FAYETTE URBAN COUNTY GOVERNMENT
LEXINGTON, KY

All prime Contractors shall certify that Subcontractors have not and will not be awarded to any firms that has been debarred for noncompliance with the Federal Labor Standards, Title VI of the Civil Rights Act of 1964 As Amended, Executive Order 11246 As Amended or any other Federal Law.

All bidders shall complete the attached certification in duplicate and submit both copies to the Owner with the bid proposal. The Owner (grantee) shall transmit one copy to the Lexington-Fayette Urban County Government, Division of Community Development, within fourteen (14) days after bid opening.

The undersigned hereby certifies that the firm of Rio Grande Fence Company has not and will not award a subcontract, in connection with any contract award to it as the result of this bid, to any firm that has been debarred for noncompliance with the Federal labor Standards, Title VI of the civil Rights Act of 1964, Executive Order 11246 as amended or any Federal Law.

Rio Grande Fence Company
Name of Firm Submitting Bid

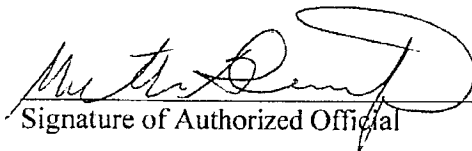
Signature of Authorized Official

President
Title

4/8/13
Date

19. DEBARMENT CERTIFICATION

All contractors/subcontractors shall complete the following certification and submit it with the bid proposal.

The contractor/subcontractor certifies in accordance with Executive Order 12549 (Debarment and Suspension 2/18/86) that to the best of its knowledge and belief, that it and its principals:

- 1) Are not presently debarred, suspended, proposed for debarment, declared negligible, or voluntarily excluded from covered transactions or contract by any Federal department or agency for noncompliance with the Federal Labor Standards, Title VI of the Civil Rights Act of 1964 as amended, Executive Order 11246 as amended or any other Federal law;
 - a) Have not within a three year period preceding this proposal been convicted of or had a civil judgment rendered against them for commission of fraud or a criminal offense in connection with obtaining, attempting to obtain, or performing a public (Federal, State or local) transaction or contract under a public transaction; violation of Federal or State antitrust statutes or commission of embezzlement, theft, forgery, bribery, falsification or destruction of records, making false statements, or receiving stolen property;
 - b) Are not presently indicted for or otherwise criminally or civilly charged by a government entity (Federal, State or local) with commission of any of the offenses enumerated in paragraph (1)(a) of this certification; and
 - c) Have not within a three year period preceding this bid has one or more public (Federal, State or local) transactions or contracts terminated for cause or default.
- 2) Where the contractor is unable to certify to any of the statements in this certification, such prospective contractors shall attach an explanation to this certification form.

Firm Name: Rio Grande Fence Company

Project: New Chainlink dug outs

Printed Name and Title of Authorized Representative: President

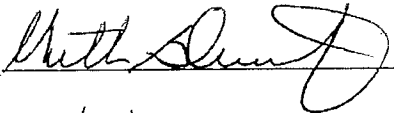
Signature: 

Date: 4/8/13

END OF SECTION



**Liberty
Mutual**
SURETY

The Ohio Casualty Insurance Company

BID OR PROPOSAL BOND

KNOW ALL MEN BY THESE PRESENTS, That we,

Rio Grande Fence Company, Inc.
of 137 South Forbes Road, Lexington, Kentucky 40511
(hereinafter called the Principal) as Principal, and The Ohio Casualty Insurance Company, with its
principal office in the City of Keene, New Hampshire (hereinafter called the Surety), as Surety, are held and firmly bound
unto Lexington-Fayette Urban County Government
of Lexington, Kentucky
(hereinafter called the Obligee) in the penal sum of

5% of Bid Amount
Dollars \$ _____ lawful money of the United States, for the payment of which sum well and truly to be made,
we bind ourselves, our heirs, executors, administrators, successors, and assigns.

THE CONDITION OF THIS OBLIGATION IS SUCH, that whereas, the Principal has submitted the
accompanying bid dated April 8, 2013 for
Baseball Fields, various locations

NOW, THEREFORE, if the Obligee shall make any award according to the terms of said bid and the Principal shall enter
into a contract with said Obligee in accordance with the terms of said bid and give bond for the faithful performance thereof
within the time specified; or if no time is specified within thirty days after the date of said award; or if the Principal shall, in
the case of failure so to do, indemnify the Obligee against any loss the Obligee may suffer directly arising by reason of such
failure, not exceeding the penalty of this bond, then this obligation shall be null and void; otherwise to remain in full force
and virtue.

Signed, sealed and dated: April 8, 2013

Rio Grande Fence Company, Inc.
(Principal)

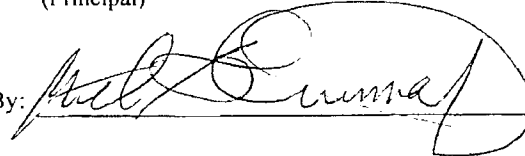
By: 

The Ohio Casualty Insurance Company

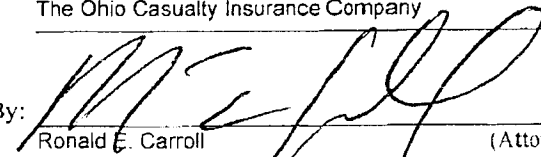
By: 
Ronald E. Carroll (Attorney-in-Fact)
Carroll & Stone Insurance, 859-269-1044

Principal: Rio Grande Fence Company, Inc

POWER OF ATTORNEY
THE OHIO CASUALTY INSURANCE COMPANY

Agency Name: CARROLL INS AGCY

Obligee: Lexington-Fayette Urban County Government

Agent Code: 161361

Bond Number:

Know All Men by These Presents: That THE OHIO CASUALTY INSURANCE COMPANY, a New Hampshire Corporation, pursuant to the authority granted by Article IV, Section 12 of the Code of Regulations and By-Laws of The Ohio Casualty Insurance Company, do hereby nominate, constitute and appoint. Ronald E. Carroll, Stephen E. Carroll, Kelly Stone of LEXINGTON, Kentucky its true and lawful agent(s) and attorney(ies)-in-fact, to make, execute, seal and deliver for and on its behalf as surety, and as its act and deed any and all BONDS, UNDERTAKINGS, and RECOGNIZANCES, excluding, however, any bond(s) or undertaking(s) guaranteeing the payment of notes and interest thereon.

And the execution of such bonds or undertakings in pursuance of these presents, shall be as binding upon said Company, as fully and amply, to all intents and purposes, as if they had been duly executed and acknowledged by the regularly elected officers of said Company at their administrative offices in Keene, NH, in their own proper persons. The authority granted hereunder supersedes any previous authority heretofore granted the above named attorney(ies)-in-fact.

IN WITNESS WHEREOF, the undersigned officer of the said The Ohio Casualty Insurance Company has hereunto subscribed his name and affixed the Corporate Seal of said Company this 1st day of December, 2012.



Gregory W. Davenport Assistant Secretary

STATE OF WASHINGTON
COUNTY OF KING

On this 1st day of December, 2012 before the subscriber, a Notary Public of the State of Washington, in and for the County of King, duly commissioned and qualified, came Gregory W. Davenport, Assistant Secretary of The Ohio Casualty Insurance Company, to me personally known to be the individual and officer described in, and who executed the preceding instrument, and he acknowledged the execution of the same, and being by me duly sworn deposes and says that he is the officer of the Company aforesaid, and that the seal affixed to the preceding instrument is the Corporate Seal of said Company, and the said Corporate Seal and his signature as officer were duly affixed and subscribed to the said instrument by the authority and direction of the said Corporation.

IN TESTIMONY WHEREOF, I have hereunto set my hand and affixed my Official Seal at the City of Seattle, State of Washington, the day and year first above written.

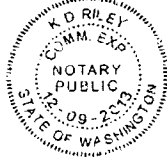

Notary Public in and for County of King, State of Washington
My Commission expires December 9, 2013

This power of attorney is granted under and by authority of Article IV, Section 12 of the By-Laws of The Ohio Casualty Insurance Company, extracts from which read

ARTICLE IV - Officers Section 12 Power of Attorney.

Any officer or other official of the Corporation authorized for that purpose in writing by the Chairman or the President, and subject to such limitation as the Chairman or President may prescribe, shall appoint such attorneys-in-fact, as may be necessary to act in behalf of the Corporation to make, execute, seal, acknowledge and deliver as surety any and all undertakings, bond, recognizances and other surety obligations. Such attorneys-in-fact, subject to the limitations set forth in their respective powers of attorney, shall have full power to bind the Corporation by their signature and execution of any such instruments and to attach thereto the seal of the Corporation. When so executed, such instruments shall be as binding as if signed by the President and attested to by the Secretary.

Any power or authority granted to any representative or attorney-in-fact under the provisions of this article may be revoked at any time by the Board, the Chairman, the President or by the officer or officers granting such power or authority.

This certificate and the above power of attorney may be signed by facsimile or mechanically reproduced signatures under and by authority of the following vote of the board of directors of The Ohio Casualty Insurance Company effective on the 15th day of February, 2011:

VOTED that the facsimile or mechanically reproduced signature of any assistant secretary of the company, wherever appearing upon a certified copy of any power of attorney issued by the company in connection with surety bonds, shall be valid and binding upon the company with the same force and effect as though manually affixed

CERTIFICATE

I, the undersigned Assistant Secretary of The Ohio Casualty Insurance Company, do hereby certify that the foregoing power of attorney, the referenced By-Laws of the Company and the above resolution of their Board of Directors are true and correct copies and are in full force and effect on this date
IN WITNESS WHEREOF, I have hereunto set my hand and the seal of the Company this 8th day of April 2013



David M. Carey Assistant Secretary

PART IV

GENERAL CONDITIONS

TABLE OF CONTENTS

Article Number	Title	Page
1.	DEFINITIONS.....	GC-6
2.	PRELIMINARY MATTERS	GC-10
3.	CONTRACT DOCUMENTS: INTENT, CONFLICTS, AMENDING AND REUSE	GC-11
4.	AVAILABILITY OF LANDS; PHYSICAL CONDITIONS; REFERENCE POINTS	GC-13
5.	CONTRACTOR'S RESPONSIBILITIES.....	GC-15
6.	OTHER WORK.....	GC-26
7.	OWNER'S RESPONSIBILITIES.....	GC-27
8.	OWNER'S STATUS DURING CONSTRUCTION	GC-27
9.	CHANGES IN THE WORK	GC-30
10.	CHANGE OF CONTRACT PRICE	GC-31
11.	CHANGE OF CONTRACT TIME.....	GC-38
12.	WARRANTY AND GUARANTEE; TESTS AND INSPECTIONS; CORRECTION, REMOVAL OR ACCEPTANCE OF DEFECTIVE WORK.....	GC-38
13.	PAYMENTS TO CONTRACTOR AND COMPLETION.....	GC-42
14.	SUSPENSION OF WORK AND TERMINATION	GC-45
15.	MISCELLANEOUS.....	GC-48

DETAILED TABLE OF CONTENTS OF GENERAL CONDITIONS

1. Definitions
2. Preliminary Matters
 - 2.1 Delivery of Bonds
 - 2.2 Copies of Documents
 - 2.3 Commencement of Contract Time; Notice to Proceed
 - 2.4 Starting the Project
 - 2.5 Before Starting Construction
 - 2.6 Submittal of Schedules
 - 2.7 Preconstruction Conference
 - 2.8 Finalizing Schedules
3. Contract Documents, Intent, Conflicts, Amending, and Reuse
 - 3.1 General
 - 3.2 Intent
 - 3.3 Conflicts
 - 3.4 Amending and Supplementing Contract Documents
 - 3.5 Reuse of Documents
4. Availability of Lands, Physical Conditions, Reference Points
 - 4.1 Availability of Lands
 - 4.2 Physical Conditions
 - 4.3 Physical Conditions - Underground Facilities
 - 4.4 Reference Points
5. CONTRACTOR'S Responsibilities
 - 5.1 Supervision
 - 5.2 Superintendence
 - 5.3 Labor
 - 5.4 Start-Up and Completion of Work
 - 5.5 Materials and Equipment
 - 5.6 Adjusting Progress Schedule
 - 5.7 Substitutes or "Or-Equal" Items
 - 5.8 Subcontractors, Suppliers and Others
 - 5.9 Patent Fees and Royalties
 - 5.10 Permits
 - 5.11 Laws and Regulations
 - 5.12 Taxes
 - 5.13 Use of Premises

- 5.14 Record Drawings
- 5.15 Shop Drawings and Samples
- 5.16 Continuing the Work
- 5.17 Erosion and Sediment Control

- 6. Other Work
 - 6.1 Related Work at Site
 - 6.2 Other Contractors or Utility Owners
 - 6.3 Delays Caused By Others
 - 6.4 Coordination

- 7. OWNER'S Responsibilities
 - 7.1 Communications
 - 7.2 Data and Payments
 - 7.3 Lands, Easements, and Surveys
 - 7.4 Change Orders
 - 7.5 Inspections, Tests, and Approvals
 - 7.6 Stop or Suspend Work

- 8. OWNER'S Status During Construction
 - 8.1 OWNER'S Representative
 - 8.2 Visits to Site
 - 8.3 Project Representation
 - 8.4 Clarification and Interpretations
 - 8.5 Authorized Variations in Work
 - 8.6 Rejecting Defective Work
 - 8.7 Shop Drawings
 - 8.8 Change Orders
 - 8.9 Payments
 - 8.10 Determinations for Unit Prices
 - 8.11 Decisions on Disputes
 - 8.12 Limitations on OWNER'S Responsibilities

- 9. Changes in the Work
 - 9.1 OWNER May Order Changes
 - 9.2 Claims
 - 9.3 Work Not in Contract Documents
 - 9.4 Change Orders
 - 9.5 Notice of Change

- 10. Change of Contract Price
 - 10.1 Total Compensation
 - 10.2 Claim for Increase or Decrease in Price
 - 10.3 Value of Work
 - 10.4 Cost of the Work
 - 10.5 Not to Be Included in Cost of the Work
 - 10.6 CONTRACTOR'S Fee
 - 10.7 Itemized Cost Breakdown
 - 10.8 Cash Allowance
 - 10.9 Unit Price Work

- 11. Change of Contract Time
 - 11.1 Change Order
 - 11.2 Justification for Time Extension
 - 11.3 Time Limits

- 12. Warranty and Guarantee; Tests and Inspections; Correction, Removal or Acceptance of Defective Work
 - 12.1 Warranty and Guarantee
 - 12.2 Access to Work
 - 12.3 Tests and Inspections
 - 12.4 OWNER May Stop Work
 - 12.5 Correction or Removal of Defective Work
 - 12.6 One Year Correction Period
 - 12.7 Acceptance of Defective work
 - 12.8 Owner May Correct Defective Work

- 13. Payments to CONTRACTOR and Completion
 - 13.1 Schedule of Values
 - 13.2 Application for Progress Payments
 - 13.3 CONTRACTOR'S Warranty of Title
 - 13.4 Review of Application for Progress Payments
 - 13.5 Partial Utilization
 - 13.6 Final Inspection
 - 13.7 Final Application for Payment
 - 13.8 Final Payment and Acceptance
 - 13.9 CONTRACTOR'S Continuing Obligation
 - 13.10 Waiver of Claims

14. Suspension of Work and Termination

- 14.1 OWNER May Suspend Work
- 14.2 OWNER May Terminate
- 14.3 CONTRACTOR'S Services Terminated
- 14.4 Payment After Termination
- 14.5 CONTRACTOR May Stop or Terminate

15. Miscellaneous

- 15.1 Claims for Injury or Damage
- 15.2 Non-Discrimination in Employment
- 15.3 Temporary Street Closing or Blockage
- 15.4 Percentage of Work Performed by Prime CONTRACTOR
- 15.5 Clean-up
- 15.6 General
- 15.7 Debris Disposal
- 15.8 Close Out Procedures

END OF SECTION

PART IV

GENERAL CONDITIONS

1. **DEFINITIONS**

Wherever used in these General Conditions or the other Contract Documents, the following terms have the meanings indicated which are applicable to both the singular and plural thereof.

1.1 Addenda

Written or graphic instruments issued prior to the opening of Bids which clarify, correct, or change the Bid Documents or the Contract Documents.

1.2 Agreement

The written agreement between OWNER and CONTRACTOR covering the Work to be performed; other Contract Documents are attached to the Agreement and made a part thereof as provided therein.

1.3 Application for Payment

The form accepted by OWNER which is to be used by CONTRACTOR in requesting progress or final payments and which is to include such supporting documentation as is required by the Contract Documents.

1.4 Bid

The offer or proposal of the Bidder submitted on the prescribed form setting forth the prices for the Work to be performed.

1.5 Bidder

An individual, partnership, or corporation, who submit a Bid for a prime contract with the OWNER, for the Work described in the proposed Contract Documents.

1.6 Bonds

Bid, performance and payment bonds and other instruments of security.

1.7 Calendar Day

A calendar day of twenty-four hours measured from midnight to the next midnight shall constitute a day.

1.8 Change Order

A document recommended by OWNER, which is signed by CONTRACTOR and OWNER and authorizes an addition, deletion or revision in the Work, or an adjustment in the Contract Price or the Contract Time, issued on or after the Effective Date of the Agreement.

1.9 Contract Documents

The Advertisement for Bidders, Information for Bidders, Agreement, Addenda (which pertain to the Contract Documents), CONTRACTOR'S Bid (including documentation accompanying the Bid and any post-bid documentation submitted prior to the Notice of Award) when attached as an exhibit to the Agreement, the Bonds, these General Conditions, the Special Conditions, the Specifications and the Drawings as the same are more specifically identified in the Agreement, together with all amendments, modifications and supplements.

1.10 Contract Unit Price

The monies payable by OWNER to CONTRACTOR under the Contract Documents as stated in the Agreement. Unit Prices are to be firm for the term of this Contract.

1.11 Contract Time

The number of consecutive calendar days between the date of issuance of the Notice to Proceed and the contract completion date.

1.12 CONTRACTOR

The person, firm or corporation with whom OWNER has entered into the Agreement.

1.13 Defective

An adjective which when modifying the word Work refers to Work that is unsatisfactory, faulty or deficient, or does not conform to the Contract Documents, or does not meet the requirements of any inspection, reference standard, test or approval referred to in the Contract Documents, or has been damaged prior to OWNER'S recommendation of final payment (unless responsibility for the protection thereof has been assumed by OWNER).

1.13 Drawings

The drawings which show the character and scope of the Work to be performed and which have been prepared or approved by OWNER and are referred to in the Contract Documents.

1.15 Effective Date of the Agreement

The date indicated in the Agreement on which it becomes effective.

1.16 ARCHITECT [NOT USED]

Consultant hired by the Lexington-Fayette Urban County Government Division Department of General Services to represent OWNER on the Project.

1.17 Field Order

A documented order issued by OWNER which orders minor changes in the Work, but which does not involve a change in the Contract Price or the Contract Time.

1.18 Giving Notice

Whenever any provision of the Contract Documents requires the giving of written notice, it will be deemed to have been validly given if delivered in person to the individual or to a member of the firm or to an officer of the corporation for whom it is intended, or if delivered at or sent by registered or certified mail, postage prepaid, to the last business address known to the giver of the notice.

1.19 Laws and Regulations

Laws, rules, regulations, ordinances, codes and/or orders.

1.20 Notice of Award

The written notice by OWNER to the apparent successful bidder stating that upon compliance by the apparent successful bidder with the conditions enumerated therein, within the time specified, OWNER will sign and deliver the Agreement.

1.21 Notice to Proceed

A written notice given by OWNER to CONTRACTOR fixing the date on which the Contract Time will commence to run and on which CONTRACTOR shall start to perform CONTRACTOR'S obligations under the Contract Documents.

1.22 OWNER

The Lexington-Fayette Urban County Government, Department of General Services or its authorized representative.

1.23 Partial Utilization

Placing a portion of the Work in service for the purpose for which it is intended (or related purpose) before reaching Completion for all the Work.

1.24 Project

The total construction of which the Work to be provided under the Contract Documents may be the whole, or a part as indicated elsewhere in the Contract Documents.

1.25 Inspector

The authorized representative of the OWNER who is assigned to the site or any part thereof.

1.26 Shop Drawings

All drawings, diagrams, illustrations, schedules and other data which are specifically prepared by or for CONTRACTOR to illustrate some portion of the Work and all illustrations, brochures, standard schedules, performance charts, instructions, diagrams and other information prepared by a Supplier and submitted by CONTRACTOR to illustrate material or equipment for some portion of the Work.

1.27 Specifications

Those portions of the Contract Documents consisting of written technical descriptions of materials, equipment, construction systems, standards and workmanship as applied to the Work and certain administrative details applicable thereto.

1.28 Standard Specifications

Those portions of the Contract Documents consisting of written technical descriptions of materials, equipment, construction systems, standards and workmanship as applied to the Work and certain administrative details applicable thereto.

1.29 Subcontractor

An individual, firm or corporation having a direct contract with CONTRACTOR or with any other Subcontractor for the performance of a part of the Work at the site.

1.30 Special Conditions

The part of the Contract Documents which amends or supplements these General Conditions.

1.31 Supplier

A manufacturer, fabricator, supplier, distributor, materialman or vendor.

1.32 Underground Facilities

All pipelines, conduits, ducts, cables, wires, manholes, vaults, tanks, tunnels or other such facilities or attachments, and any encasements containing such facilities which have been installed underground to furnish any of the following services or materials: electricity, gases, steam, liquid petroleum products, telephone or other communications, cable television, sewage and drainage removal, traffic or other control systems or water.

1.33 Unit Price Work

Not applicable

1.34 Work

The entire completed construction or the various separately identifiable parts thereof required to be furnished under the Contract Documents. Work is the result of performing services, furnishing labor and furnishing and incorporating materials and equipment into the construction, all as required by the Contract Documents.

1.35 Time Period

When any period of time is referred to in the Contract Documents by days, it will be computed to exclude the first and include the last day of such period. If the last day of any such period falls on a Saturday or Sunday or on a day made a legal holiday by the law of the applicable jurisdiction, such day will be omitted from the computation.

2. PRELIMINARY MATTERS

2.1 Delivery of Bonds

When the CONTRACTOR delivers the executed Agreements to OWNER, CONTRACTOR shall also deliver to OWNER, such Bonds, Insurance Certificate, and Power of Attorney as CONTRACTOR may be required to furnish.

2.2 Copies of Documents

OWNER shall furnish to CONTRACTOR up to three copies (unless otherwise specified in the Special Conditions) of the Contract Documents as are reasonably necessary for the execution of the Work. Additional copies will be furnished, upon request, at the cost of reproduction.

2.3 Commencement of Contract Time; Notice to Proceed

The Contract Time will commence to run on the day specified in the Notice to Proceed.

2.4 Starting the Project

CONTRACTOR shall start to perform the Work on the date when the Contract Time commences to run, but no Work shall be done at the site prior to the date on which the Contract Time commences to run.

2.5 Before Starting Construction

Before undertaking each part of the Work, CONTRACTOR shall carefully study and compare the Contract Documents and check and verify pertinent figures shown thereon and all applicable field measurements. CONTRACTOR shall promptly report in writing to OWNER any conflict, error or discrepancy which CONTRACTOR may discover and shall obtain a written interpretation or clarification from OWNER before proceeding with any Work affected thereby; however, CONTRACTOR shall not be liable to OWNER for failure to report any conflict, error or discrepancy in the Contract Documents, unless CONTRACTOR had actual knowledge thereof or should reasonably have known thereof.

2.6 Submittal of Schedules

Within ten days after the effective date of the Agreement (unless otherwise specified) CONTRACTOR shall submit to OWNER for review:

2.6.1 an estimated progress schedule indicating the starting and completion dates of the various stages of the Work;

2.6.2 a preliminary schedule of Shop Drawing submissions; and

2.6.3 a preliminary schedule of values for all of the Work which will include quantities and prices of items aggregating the Contract Price and will subdivide the Work into component parts in sufficient detail to serve as the

basis for progress payments during construction. Such prices will include an appropriate amount of overhead and profit applicable to each item of Work which will be confirmed in writing by CONTRACTOR at the time of submission.

2.7 Preconstruction Conference

Before CONTRACTOR starts the Work at the proposed site, a conference attended by CONTRACTOR, OWNER, EEO-Affirmative Action Officer, and other appropriate parties will be held to discuss the following issues: (1) The scheduling of the Work to be completed; (2) The procedures for handling shop drawings and other submittals; (3) The processing of applications for payment; (4) The establishment of an understanding among the involved parties in regard to the proposed project; and (5) The establishment of procedures for effectively implementing the LFUCG's 10% minimum DBE goals.

2.8 Finalizing Schedules

At least ten days before submission of the first Application for Payment a conference attended by CONTRACTOR, OWNER and others as appropriate will be held to finalize the schedules submitted in accordance with paragraph 2.6. The finalized progress schedule will be acceptable to OWNER as providing orderly progression of the Work to completion within the Contract Time, but such acceptance will neither impose on OWNER responsibility for the progress or scheduling of the Work nor relieve CONTRACTOR from full responsibility thereof. The finalized schedule of Shop Drawing submissions will be acceptable to OWNER as providing a workable arrangement for processing the submissions. The finalized schedule of values will be acceptable to OWNER as to form and substance.

3. CONTRACT DOCUMENTS: INTENT, CONFLICTS, AMENDING AND REUSE

3.1 General

The Contract Documents comprise the entire agreement between OWNER and CONTRACTOR concerning the Work. The Contract Documents are complementary; what is called for by one is as binding as if called for by all. The Contract Documents will be construed in accordance with the law of the place of the Project.

3.2 Intent

It is the intent of the Contract Documents to describe a functionally complete Project (or part thereof) to be constructed in accordance with the Contract Documents. Any Work, materials or equipment that may reasonably be inferred from the Contract Documents as being required to produce the intended result will be supplied whether or not specifically called for. When words which have a well-known technical or trade meaning are used to describe Work, materials or equipment such words shall be interpreted in accordance with that meaning. Reference to standard specifications, manuals or codes of any technical society, organization or association, or to the laws or regulations of any

governmental authority, whether such reference be specific or by implication, shall mean the latest standard specification, manual, code or laws or regulations in effect at the time of opening of Bids (or, on the Effective Date of the Agreement if there were no Bids), except as may be otherwise specifically stated. However, no provision of any referenced standard specification, manual or code (whether or not specifically incorporated by reference in the Contract Documents) shall be effective to change the duties and responsibilities of OWNER or CONTRACTOR, or any of their consultants, agents or employees from those set forth in the Contract Documents, nor shall it be effective to assign to OWNER, or any of OWNER'S consultants, agents or employees, any duty or authority to supervise or direct the furnishing or performance of the Work or any duty or authority to undertake responsibility contrary to the provisions of paragraph 8.12.3 or 8.12.4. Clarifications and interpretations of the Contract Documents shall be issued by OWNER as provided in paragraph 8.4.

3.3 Conflicts

If, during the performance of the Work, CONTRACTOR finds a conflict, error or discrepancy in the Contract Documents, CONTRACTOR shall so report to OWNER in writing at once and before proceeding with the Work affected thereby shall obtain a written interpretation or clarification from OWNER; however, CONTRACTOR shall not be liable to OWNER for failure to report any conflict, error or discrepancy in the Contract Documents unless CONTRACTOR had actual knowledge thereof or should reasonably have known thereof.

In resolving such conflicts, errors and discrepancies, the documents shall be given precedence in the following order:

1. Agreement
2. Field and Change Orders
3. Addenda
4. Special Conditions
5. Instruction to Bidders
6. General Conditions
7. Specifications and Drawings

Figure dimension on drawings shall govern over scale dimensions and detailed Drawings shall govern over general Drawings.

3.4 Amending and Supplementing Contract Documents

The Contract Documents may be amended to provide for additions, deletions and revisions in the Work or to modify the terms and conditions thereof by means of a Change Order or a Field Order. Contract Price and Contract Time may only be changed by a Change Order.

3.5 Reuse of Documents

Neither CONTRACTOR nor any Subcontractor or Supplier or other person or organization performing or furnishing any of the Work under a direct or indirect

contract with OWNER shall have or acquire any title to or ownership rights in any of the Drawings, Specifications or other documents (or copies of any thereof) prepared by OWNER; and they shall not reuse any of them on extensions of the Project or any other project without written consent of OWNER and specific written verification or adaptation by OWNER.

4. AVAILABILITY OF LANDS; PHYSICAL CONDITIONS, REFERENCE POINTS

4.1 Availability of Lands

OWNER shall furnish, as indicated in the Contract Documents, the lands upon which the Work is to be performed, rights-of-way and easements for access thereto, and such other lands which are designated for the use of CONTRACTOR. Easements for permanent structures or permanent changes in existing facilities will be obtained and paid for by OWNER, unless otherwise provided in the Contract Documents. If CONTRACTOR believes that any delay in OWNER'S furnishing these lands, rights-of-way or easements entitles CONTRACTOR to an extension of the Contract Time, CONTRACTOR may make a claim therefor as provided in Article 11. OWNER shall determine if the claim is legitimate or not. CONTRACTOR shall provide for all additional lands and access thereto that may be required for temporary construction facilities or storage of materials and equipment.

4.2 Physical Conditions

4.2.1 Explorations and Reports

Reference is made to the Special Conditions for identification of those reports of explorations and tests of subsurface conditions at the site that have been utilized by OWNER in preparation of the Contract Documents. CONTRACTOR may rely upon the accuracy of the technical data contained in such reports, but not upon non-technical data, interpretations or opinions contained therein or for the completeness thereof for CONTRACTOR'S purposes. Except as indicated in the immediately preceding sentence and in paragraph 4.2.6, CONTRACTOR shall have full responsibility with respect to subsurface conditions at the site.

4.2.2 Existing Structures

Reference is made to the Special Conditions for identification of those drawings of physical conditions in or relating to existing surface and subsurface structures (except Underground Facilities referred to in paragraph 4.3 which are at or contiguous to the site that have been utilized by OWNER in preparation of the Contract Documents. CONTRACTOR may rely upon the accuracy of the technical data contained in such drawings, but not for the completeness thereof for CONTRACTOR'S purposes. Except as indicated in the immediately preceding sentence and in paragraph 4.2.6, CONTRACTOR shall have full responsibility with respect to physical conditions in or relating to such structures.

4.2.3 Report of Differing Conditions

If CONTRACTOR believes that:

4.2.3.1 any technical data on which CONTRACTOR is entitled to rely as provided in paragraphs 4.2.1 and 4.2.2 is inaccurate, or

4.2.3.2 any physical conditions uncovered or revealed at the site differ materially from that indicated, reflected or referred to in the Contract Documents,

CONTRACTOR shall, promptly after becoming aware thereof and before performing and WORK in connection therewith (except in an emergency) notify OWNER in writing about the inaccuracy or difference.

4.2.4 OWNER'S Review

OWNER will promptly review the pertinent conditions, determine the necessity of obtaining additional explorations or tests with respect thereto and advise CONTRACTOR of OWNER'S findings and conclusions.

4.2.5 Possible Document Change

If OWNER concludes that there is a material error in the Contract Documents or that because of newly discovered conditions a change in the Contract Documents is required, a Change Order will be issued as provided in Article 10 to reflect and document the consequences of the inaccuracy or difference.

4.2.6 Possible Price and Time Adjustments

In each such case, an increase or decrease in the Contract Price or an extension or shortening of the Contract Time, or any combination thereof, will be allowable to the extent that they are attributable to any such inaccuracy or difference.

4.3 Physical Conditions-Underground Facilities

4.3.1 Shown or Indicated

The information and data shown or indicated in the Contract Documents with respect to existing Underground Facilities at or contiguous to the site is based on information and data furnished to OWNER by the owners of such underground facilities or by others. Unless it is otherwise expressly provided in the Special Conditions:

4.3.1.1 OWNER shall not be responsible for the accuracy or completeness of any such information or data; and,

4.3.1.2 CONTRACTOR shall have full responsibility for reviewing and checking all such information and data; for locating all underground facilities shown or indicated in the Contract Documents; for coordination of the Work with the owners of such underground facilities during construction; and for the safety and protection thereof and repairing any damage thereto

resulting from the Work, the cost of all of which will be considered as having been included in the Contract Price.

4.3.2 Not Shown or Indicated

If an underground facility is uncovered or revealed at or contiguous to the site which was not shown or indicated in the Contract Documents and which CONTRACTOR could not reasonably have been expected to be aware of, CONTRACTOR shall, promptly after becoming aware thereof and before performing any Work affected thereby (except in an emergency), identify the owner of such Underground Facility and give written notice thereof to that owner and to OWNER. OWNER will promptly review the underground facility to determine the extent to which the Contract Documents should be modified to reflect and document the consequences of the existence of the Underground Facility, and the Contract Documents will be amended or supplemented to the extent necessary. During such time, CONTRACTOR shall be responsible for the safety and protection of such underground facility. CONTRACTOR shall be allowed an increase in the Contract Price or an extension of the Contract Time, or both, to the extent that they are attributable to the existence of any underground facility that was not shown or indicated in the Contract Documents and which CONTRACTOR could not reasonably have been expected to be aware of.

4.4 **Reference Points [NOT USED]**

OWNER shall provide engineering surveys to establish reference points for construction which in OWNER'S judgment are necessary to enable CONTRACTOR to proceed with the Work. CONTRACTOR shall be responsible for laying out the Work (unless otherwise specified), shall protect and preserve the established reference points and shall make no changes or relocations without the prior written approval of OWNER. CONTRACTOR shall report to OWNER whenever any reference point is lost or destroyed or requires relocation because of necessary changes in grades or locations, and shall be responsible for the accurate replacement or relocation of such reference points by a Registered Land Surveyor.

5. **CONTRACTOR'S RESPONSIBILITIES**

5.1 **Supervision**

CONTRACTOR shall supervise and direct the Work competently and efficiently, devoting such attention thereto and applying such skills and expertise as may be necessary to perform the Work in accordance with the Contract Documents. CONTRACTOR shall assure that all CONTRACTOR personnel (including subcontractors, etc.) conduct themselves in a courteous and respectful manner toward the OWNER and the general public. Failure to comply with this condition of the Contract will result in immediate suspension of the Work. Following a review by the Commissioner of Public Works, the Contract may be terminated (see GC section 14). CONTRACTOR shall be solely responsible for the means, methods, techniques, sequences and procedures of construction, but CONTRACTOR shall not be responsible for the negligence of others in the design or selection of a specific

means, method, technique, sequence or procedure of construction which is indicated in and required by the Contract Documents. CONTRACTOR shall be responsible to see that the finished Work complies accurately with the Contract Documents.

5.2 Superintendence

CONTRACTOR shall keep on the Work at all times during its progress a competent resident superintendent, who shall not be replaced without written notice to OWNER except under extraordinary circumstances. The superintendent will be CONTRACTOR'S representative at the site and shall have authority to act on behalf of CONTRACTOR. All communications given to the superintendent shall be as binding as if given to CONTRACTOR.

5.3 Labor

CONTRACTOR shall provide competent, suitably qualified personnel to survey and lay out the Work and perform construction as required by the Contract Documents. CONTRACTOR shall at all times maintain good discipline and order at the site. Except in connection with the safety or protection of persons or the Work or property at the site or adjacent thereto, and except as otherwise indicated in the Contract Documents, all Work at the site shall be performed during regular working hours, and CONTRACTOR will not permit overtime work or the performance of Work on Saturday, Sunday or any legal holiday without OWNER'S written consent given after prior written notice to OWNER.

5.4 Start-Up and Completion of Work

Unless otherwise specified, CONTRACTOR shall furnish and assume full responsibility for all materials, equipment, labor, transportation, construction equipment and machinery, tools, appliances, fuel, power, light, heat, telephone, water, sanitary facilities, temporary facilities and all other facilities and incidentals necessary for the furnishing, performance, testing, start-up and completion of the Work.

5.5 Materials and Equipment

All materials and equipment shall be of good quality and new, except as otherwise provided in the Contract Documents. If required by OWNER, CONTRACTOR shall furnish satisfactory evidence (including reports of required tests) as to the kind and quality of materials and equipment. All materials and equipment shall be applied, installed, connected, erected, used, cleaned and conditioned in accordance with the instructions of the applicable supplier except as otherwise provided in the Contract Documents; but no provision of any such instructions will be effective to assign to OWNER, or any of OWNER'S consultants, agents or employees, any duty or authority to supervise or direct the furnishing or performance of the Work or any duty or authority to undertake responsibility contrary to the provisions of paragraph 8.12.3 or 8.12.4.

5.5.1 Not Clearly Specified or Indicated

In all instances where materials specified are obtainable in different sizes, weights, trade grades, qualities or finishes, etc., whose weights, trade grades, qualities or finishes, etc., are not clearly specified or indicated on the Drawings, the CONTRACTOR shall notify the OWNER of all such instances at least five (5) days in advance of receiving the proposals. The OWNER will then determine which size, weight, trade grade, quality, finish, etc., is required.

5.5.2 Coordination of Work

The CONTRACTOR shall see that for his own Work and for the work of each subcontractor, proper templates and patterns necessary for the coordination of the various parts of the Work are prepared. The CONTRACTOR shall furnish or require the Subcontractor to furnish such duplicates as will enable the Subcontractors to fit together and execute fully their respective portions of the Work.

5.6 Adjusting Progress Schedule

CONTRACTOR shall submit to OWNER for acceptance (to the extent indicated in paragraph 2.8) adjustments in the progress schedule to reflect the impact thereon of new developments; these will conform generally to the progress schedule then in effect and additionally will comply with any provisions of the Contract Documents applicable thereto.

5.7 Substitutes or "Or-Equal" Items

5.7.1 General

Whenever materials or equipment are specified or described in the Contract Documents by using the name of a proprietary item or the name of a particular supplier, the naming of the item is intended to establish the type, function, and quality required. Unless the name is followed by words indicating that no substitution is permitted, materials or equipment of other Suppliers may be accepted by OWNER if sufficient information is submitted by CONTRACTOR to allow OWNER to determine that the material or equipment proposed is equivalent or equal to that named. The procedure for review by OWNER will include the following. Requests for review of substitute items of material and equipment will not be accepted by OWNER from anyone, other than CONTRACTOR. If CONTRACTOR wishes to furnish or use a substitute item of material or equipment, CONTRACTOR shall make written application to OWNER for acceptance thereof, certifying that the proposed substitute will perform adequately the functions and achieve the results called for by the general design, be similar and of equal substance to that specified and be suited to the same use as that specified. The application will state that the evaluation and acceptance of the proposed substitute will not prejudice CONTRACTOR'S achievement of completion on time, whether or not acceptance of the substitute for use in the Work will require a change in any of the Contract Documents (or in the provisions of

any other direct contract with OWNER for work on the Project) to adapt the design to the proposed substitute and whether or not incorporation or use of the substitute in connection with the Work is subject to payment of any license fee or royalty. All variations of the proposed substitute from that specified will be identified in the application and available maintenance, repair and replacement service will be indicated. The application will also contain an itemized estimate of all costs that will result directly or indirectly from acceptance of such substitute, including costs of redesign and claims of other contractors affected by the resulting change, all of which shall be considered by OWNER in evaluating the proposed substitute. OWNER may require CONTRACTOR to furnish at CONTRACTOR'S expense additional data about the proposed substitute.

5.7.2 Substitutes

If a specific means, method, technique, sequence or procedure of construction is indicated in or required by the Contract Documents, CONTRACTOR may furnish or utilize a substitute means, method, sequence, technique or procedure of construction acceptable to OWNER, if CONTRACTOR submits sufficient information to allow OWNER to determine that the substitute proposed is equivalent to that indicated or required by the Contract Documents. The procedure for review by OWNER will be similar to that provided in paragraph 5.7.1 as applied by OWNER.

5.7.3 OWNER'S Approval

OWNER will be allowed a reasonable time within which to evaluate each proposed substitute. OWNER will be the sole judge of acceptability, and no substitute will be ordered, installed or utilized without OWNER'S prior written acceptance which will be evidenced by either a Change Order or an approved Shop Drawing. OWNER may require CONTRACTOR to furnish at CONTRACTOR'S expense a special performance guarantee or other surety with respect to any substitute. OWNER will record time required by OWNER and OWNER'S consultants in evaluating substitutions proposed by CONTRACTOR and in making changes in the Contract Documents occasioned thereby. Whether or not OWNER accepts a proposed substitute, CONTRACTOR shall reimburse OWNER for the charges of OWNER and OWNER'S consultants for evaluating each proposed substitute.

5.8 Subcontractors, Suppliers, and Others

5.8.1 Acceptable to OWNER

CONTRACTOR shall not employ any Subcontractor, Supplier or other person or organization (including those acceptable to OWNER as indicated in paragraph 5.8.2), whether initially or as a substitute, against whom OWNER may have reasonable objection. CONTRACTOR shall not be required to employ any Subcontractor, Supplier or other person or

organization to furnish or perform any of the Work against whom CONTRACTOR has reasonable objection.

5.8.2 Objection After Due Investigation

If the Contract Documents require the identity of certain Subcontractors, Suppliers or other persons or organizations (including those who are to furnish the principal items of materials and equipment) to be submitted to OWNER in advance of the specified date prior to the Effective Date of the Agreement for acceptance by OWNER and if CONTRACTOR has submitted a list thereof, OWNER'S acceptance (either in writing or by failing to make written objection thereto by the date indicated for acceptance or objection in the bidding documents or the Contract Documents) of any such Subcontractor, Supplier or other person or organization so identified may be revoked on the basis of reasonable objection after due investigation, in which case CONTRACTOR shall submit an acceptable substitute. No acceptance by OWNER of any such Subcontractor, Supplier or other person or organization shall constitute a waiver of any right of OWNER to reject defective Work.

5.8.3 Contractor Responsible for Acts of Subcontractors

The CONTRACTOR shall perform on the site, and with its own organization, work equivalent to at least fifty (50) percent of the total amount of Work to be performed under the Contract. This percentage may be reduced by a supplemental agreement to this Contract if, during performing the Work, the CONTRACTOR requests a reduction and the OWNER determines that the reduction would be to the advantage of the Urban County Government.

The CONTRACTOR shall, at the time he submits his proposal for the Contract, notify the OWNER in writing of the names of Subcontractors proposed for the Work. He shall not employ any Subcontractor without the prior written approval of the OWNER.

CONTRACTOR shall be fully responsible to OWNER for all acts and omissions of the Subcontractors, Suppliers and other persons and organizations performing or furnishing any of the Work under a direct or indirect contract with CONTRACTOR just as CONTRACTOR is responsible for CONTRACTOR'S own acts and omissions. Nothing in the Contract Documents shall create any contractual relationship between OWNER and any such Subcontractor, Supplier or other person or organization, nor shall it create any obligation on the part of OWNER to pay or to see to the payment of any moneys due any such Subcontractor, Supplier or other person or organization except as may otherwise be required by Laws and Regulations.

5.8.4 Division of Specifications

The divisions and sections of the Specifications and the identifications of any Drawings shall not control CONTRACTOR in dividing the Work among Subcontractors or Suppliers or delineating the Work to be performed by any specific trade.

5.8.5 Agreement Between Contractor and Subcontractors

All Work performed for CONTRACTOR by a Subcontractor will be pursuant to an appropriate agreement between CONTRACTOR and the Subcontractor which specifically binds the Subcontractor to the applicable terms and conditions of the Contract Documents for the benefit of OWNER.

5.8.6 Statements and Comments by CONTRACTOR

Neither the CONTRACTOR, his employees, nor his subcontractors shall at any time make any statement or comment as to the project scope, nature, intention, design, or construction method to any third party or parties without the explicit written consent of the OWNER.

Any third party requesting such information shall be referred to the OWNER or his representative.

Should there be any change from the original intent of the Project as a result of any statement or comment by the contractor, his employees or subcontractors, contractor shall be held liable for any change in the scope, nature, design, or construction method and shall bear the full cost for the previously mentioned changes.

5.9 Patent Fees and Royalties

CONTRACTOR shall pay all license fees and royalties and assume all costs incident to the use in the performance of the Work or the incorporation in the Work of any invention, design, process, product or device which is the subject of patent rights or copyrights held by others.

5.10 Permits

Unless otherwise provided in the Special conditions, CONTRACTOR shall obtain and pay for all construction permits and licenses. OWNER shall assist CONTRACTOR, when necessary, in obtaining such permits and licenses. CONTRACTOR shall pay all governmental charges and inspection fees necessary for the prosecution of the Work, which are applicable at the time of opening of Bids, or if there are no Bids on the Effective Date of the Agreement. CONTRACTOR shall pay all charges of utility owners for connections to the Work, and OWNER

shall pay all charges of such utility owners for capital costs related thereto such as plant investment fees.

5.11 Laws and Regulations

5.11.1 CONTRACTOR to Comply

CONTRACTOR shall give all notices and comply with all Laws and Regulations applicable to furnishing and performance of the Work. Except where otherwise expressly required by applicable Laws and Regulations, OWNER shall not be responsible for monitoring CONTRACTOR'S compliance with any Laws and Regulations.

5.11.2 Specifications and Drawings at Variance

If CONTRACTOR observes that the Specifications or Drawings are at variance with any Laws or Regulations, CONTRACTOR shall give OWNER prompt written notice thereof, and any necessary changes will be authorized by one of the methods indicated in paragraph 3.4. If CONTRACTOR performs any Work knowing or having reason to know that it is contrary to such Laws, or Regulations, and without such notice to OWNER, CONTRACTOR shall bear all costs arising therefrom; however, it shall not be CONTRACTOR'S primary responsibility to make certain that the Specifications and Drawings are in accordance with such Laws and Regulations.

Any party, firm or individual submitting a proposal pursuant to invitation must have paid all taxes owed to the Lexington-Fayette Urban County Government at the time the proposal is submitted, and must maintain a "current" status in regard to those taxes throughout the Contract. If applicable, business must be licensed in Fayette County.

5.12 Taxes

CONTRACTOR shall pay all sales, consumer, use and other similar taxes required to be paid by CONTRACTOR in accordance with the Laws and Regulations of the place of the Project which are applicable during the performance of the Work. Any party, firm or individual submitting a proposal pursuant to invitation must have paid all taxes owed to the Lexington-Fayette Urban County Government at the time the proposal is submitted, and must maintain a "current" status in regard to those taxes throughout the Contract. If applicable, business must be licensed in Fayette County.

5.13 Use of Premises

5.13.1 Project Site

CONTRACTOR shall confine construction equipment, the storage of materials and equipment and the operations of workers to the staging areas or work site areas identified in and permitted by the Contract Documents and other land and areas permitted by Laws and Regulations, rights-of-way,

permits and easements, and shall not unreasonably encumber the premises with construction equipment or other materials or equipment. CONTRACTOR shall assume full responsibility for any damage to any such land or area, or to the owner or occupant thereof or of any land or areas contiguous thereto, resulting from the performance of the Work. Should any claim be made against OWNER by any such owner or occupant because of the performance of the Work, CONTRACTOR shall promptly attempt to settle with such other party by agreement or otherwise resolve the claim by arbitration or at law. CONTRACTOR shall, to the fullest extent permitted by Laws and Regulations, indemnify and hold OWNER harmless from and against all claims, damages, losses and expenses (including, but not limited to, fees of engineers, architects, attorneys and other professionals and court and arbitration costs) arising directly, indirectly or consequentially out of any action, legal or equitable, brought by any such other party against OWNER to the extent based on a claim arising out of CONTRACTOR'S performance of the Work.

5.13.2 Clean Up

During the progress of the Work, CONTRACTOR shall keep the premises free from accumulations of waste materials, rubbish and other debris resulting from the Work. At the completion of the Work, CONTRACTOR shall remove all waste materials, rubbish and debris from and about the premises as well as all tools, appliances, construction equipment and machinery, and surplus materials, and shall leave the site clean and ready for occupancy by OWNER. CONTRACTOR shall restore to original condition all property not designated for alteration by the Contract Documents.

5.13.1 Loading of Structures

CONTRACTOR shall not load nor permit any part of any structure to be loaded in any manner that will endanger the structure, nor shall CONTRACTOR subject any part of the Work or adjacent property to stresses or pressures that will endanger it.

5.14 **Record Drawings**

CONTRACTOR shall maintain in a safe place at the site one record copy of all Drawings, Specifications, Addenda, Change Orders, Field Orders and written interpretations and clarifications (issued pursuant to paragraph 9.4) in good order and annotated to show all changes made during construction. These record documents together with all approved samples and a counterpart of all approved Shop Drawings will be available to OWNER for reference. Upon completion of the Work, these record documents, samples and Shop Drawings will be delivered to OWNER.

5.15 **Shop Drawings and Samples**

5.15.1 Shop Drawing Submittals

After checking and verifying all field measurements and after complying with applicable procedures specified, CONTRACTOR shall submit to OWNER for review and approval in accordance with the accepted schedule of Shop Drawing submissions (see paragraph 2.8), or for other appropriate action if so indicated in the Special Conditions, five copies (unless otherwise specified) of all Shop Drawings, which will bear a stamp or specific written indication that CONTRACTOR has satisfied CONTRACTOR'S responsibilities under the Contract Documents with respect to the review of the submission. All submissions will be identified as OWNER may require. The data shown on the Shop Drawings will be complete with respect to quantities, dimensions, specified performance and design criteria, materials and similar data to enable OWNER to review the information as required.

5.15.2 Sample Submittals

CONTRACTOR shall also submit to OWNER for review and approval with such promptness as to cause no delay in Work, all samples required by the Contract Documents. All samples will have been checked by and accompanied by a specific written indication that CONTRACTOR has satisfied CONTRACTOR'S responsibilities under the Contract Documents with respect to the review of the submission and will be identified clearly as to material, Supplier, pertinent data such as catalog numbers and the use for which intended.

5.15.3 Review by CONTRACTOR

Before submission of each Shop Drawing or sample CONTRACTOR shall have determined and verified all quantities, dimensions, specified performance criteria, installation requirements, materials, catalog numbers and similar data with respect thereto and reviewed or coordinated each Shop Drawing or sample with other Shop Drawings and samples and with the requirements of the Work and the Contract Documents.

5.15.4 Notice of Variation

At the time of each submission, CONTRACTOR shall give OWNER specific written notice of each variation that the Shop Drawings or samples may have from the requirements of the Contract Documents, and, in addition, shall cause a specific notation to be made on each Shop Drawing submitted to OWNER for review and approval of each such variation.

5.15.5 OWNER'S Approval

OWNER will review and approve with reasonable promptness Shop Drawings and samples, but OWNER'S review and approval will be only for conformance with the design concept of the Project and for compliance with the information given in the Contract Documents and shall not extend to means, methods, techniques, sequences or procedures of construction (except where a specific means, method, technique, sequence or procedure of construction is indicated in or required by the Contract Documents) or to

safety precautions or programs incident thereto. The review and approval of a separate item as such will not indicate approval of the assembly in which the item functions. CONTRACTOR shall make corrections required by OWNER, and shall return the required number of corrected copies of Shop Drawings and submit, as required, new samples for review and approval. CONTRACTOR shall direct specific attention in writing to revisions other than the corrections called for by OWNER on previous submittals.

5.15.6 Responsibility for Errors and Omissions

OWNER'S review and approval of Shop Drawings or samples shall not relieve CONTRACTOR from responsibility for any variation from the requirements of the Contract Documents unless CONTRACTOR has in writing called OWNER'S attention to each such variation at the time of submission as required by paragraph 5.15.4 and OWNER has given written approval of each such variation by a specific written notation thereof incorporated in or accompanying the Shop Drawing or sample approval; nor will any approval by OWNER relieve CONTRACTOR from responsibility for errors or omissions in the Shop Drawings or from responsibility for having complied with the provisions of paragraph 5.15.3.

5.15.7 Cost of Related Work

Where a Shop or sample is required by the Specifications, any related Work performed prior to OWNER'S review and approval of the pertinent submission will be the sole expense and responsibility of CONTRACTOR.

5.16 Continuing the Work

CONTRACTOR shall carry on the Work and adhere to the progress schedule during all disputes or disagreements with OWNER. No Work shall be delayed or postponed pending resolutions of any disputes or disagreements, except as permitted by paragraph 14.5 or as CONTRACTOR and OWNER may otherwise agree in writing.

5.17 Erosion and Sediment Control [NOT USED]

5.17.1 General Environmental Requirements

The CONTRACTOR and Subcontractors performing work on projects on behalf of the OWNER shall comply with all applicable federal, state, and local environmental regulations and all requirements and conditions set forth in "special" permits including but not limited to Corp of Engineers 404 permits, 401 Water Quality Certifications, Stream Crossing and Floodplain Encroachment Permits.

Any fines or penalties resulting from the failure to comply with the terms of the federal, state or local permits or perform necessary corrective action are solely the obligation of the CONTRACTOR.

5.17.2 Stormwater Pollution Prevention

A. The CONTRACTOR shall exercise due care to prevent or minimize any damage to any stream or wetland from pollution by debris, sediment or other material. The operation of equipment and/or materials in a jurisdictional wetland is expressly prohibited. Water that has been used for washing or processing, or that contains oils, sediments or other pollutants shall not be discharged from the job site. Such waters shall be collected and properly disposed of by the CONTRACTOR in accordance with applicable local, state and federal law.

B. The CONTRACTOR is solely responsible for securing all required state and local permits associated with stormwater discharges from the Project including, but not necessarily limited to the KY Notice of Intent to Disturb (NOI) for Coverage of Storm Water Discharges Associated with Construction Activities under the KPDES Storm Water General Permit KYR100000 and the LFUCG, Land Disturbance Permit. Permit application preparation and all required documentation are the responsibility of the CONTRACTOR. The CONTRACTOR is solely responsible for maintaining compliance with the stormwater pollution prevention plan or erosion and sediment control plan and ensuring the following:

- a. That the Stormwater Pollution Prevention Plan (SWPPP) or erosion control plan is current and available for review on site;
- b. That any and all stormwater inspection reports required by the permit are conducted by qualified personnel and are available for review onsite; and
- c. That all best management practices (BMPs) are adequately maintained and effective at controlling erosion and preventing sediment from leaving the site.

C. The CONTRACTOR shall provide the necessary equipment and personnel to perform any and all emergency measures that may be required to contain any spillage or leakage and to remove materials, soils or liquids that become contaminated. The collected spill material shall be properly disposed at the CONTRACTOR's expense.

D. Upon completion of the work and with the concurrence of the OWNER, the CONTRACTOR must file a Notice of Termination (NOT) of Coverage Under the KPDES General Permit for Storm Water Discharges Associated with Construction Activity with the appropriate local and state authorities.

E. Any fines or penalties resulting from the failure to comply with the terms of the state or local stormwater permits or perform necessary corrective action are solely the obligation of the CONTRACTOR.

6. OTHER WORK

6.1 Related Work at Site

OWNER may perform other work related to the Project at the site by OWNER'S own forces, have other work performed by utility owners or let other direct contracts therefore which shall contain General Conditions similar to these. If the fact that such other work is to be performed was not noted in the Contract Documents, written notice thereof will be given to CONTRACTOR prior to starting any such other work; and, if such performance will involve additional expense to CONTRACTOR or requires additional time, a Change Order to the Contract will be negotiated.

6.2 Other Contractors or Utility Owners

CONTRACTOR shall afford each utility owner and other contractor who is a party to such a direct contract (or OWNER, if OWNER is performing the additional work with OWNER'S employees) proper and safe access to the site and a reasonable opportunity for the introduction and storage of materials and equipment and the execution of such work, and shall properly connect and coordinate the Work with theirs. CONTRACTOR shall do all cutting, fitting and patching of the Work that may be required to make its several parts come together properly and integrate with such other work. CONTRACTOR shall not endanger any work of others by cutting, excavating or otherwise altering their work and will only cut or alter their work with the written consent of OWNER and the others whose work will be affected. The duties and responsibilities of CONTRACTOR under this paragraph are for the benefit of such utility owners and other contractors to the extent that there are comparable provisions for the benefit of CONTRACTOR in said direct contracts between OWNER and such utility owners and other contractors.

6.3 Delays Caused by Others

If any part of CONTRACTOR'S Work depends for proper execution or results upon the work of any such other contractor or utility owner (or OWNER), CONTRACTOR shall inspect and promptly report to OWNER in writing any delays, defects or deficiencies in such work that render it unavailable or unsuitable for such proper execution and results. CONTRACTOR'S failure so to report will constitute an acceptance of the other work as fit and proper for integration with CONTRACTOR'S Work except for latent or non-apparent defects and deficiencies in the other work.

6.4 Coordination

If OWNER contracts with others for the performance of other work on the Project at the site, the person or organization who will have authority and responsibility for coordination of the activities among the various prime contractors will be identified in the Special Conditions, and the specific matters to be covered by such authority and responsibility will be itemized, and the extent of such authority and responsibilities will be provided, in the Special Conditions.

7. OWNER'S RESPONSIBILITIES

7.1 Communications

OWNER shall issue all communications to CONTRACTOR.

7.2 Data and Payments

OWNER shall furnish the data required of OWNER under the Contract Documents promptly after they are due.

7.3 Lands, Easements, and Surveys

OWNER'S duties in respect of providing lands and easements and providing engineering surveys to establish reference points are set forth in paragraphs 4.1 and 4.4. Paragraph 4.2 refers to OWNER'S identifying and making available to CONTRACTOR copies of reports of explorations and tests of subsurface conditions at the site and in existing structures which have been utilized by OWNER in preparing the Drawings and Specifications.

7.4 Change Orders

OWNER is obligated to execute Change Orders as indicated in paragraph 9.4.

7.5 Inspections, Tests and Approvals

OWNER'S responsibility in respect to certain inspections, tests and approvals is set forth in paragraph 13.3.

7.6 Stop or Suspend Work

In connection with OWNER'S right to stop Work or suspend Work, see paragraph 12.4 and 14.1 Paragraph 14.2 deals with OWNER'S rights to terminate services of CONTRACTOR under certain circumstances.

8. OWNER'S STATUS DURING CONSTRUCTION

8.1 OWNER'S Representative [NOT USED]

ARCHITECT will be OWNER'S representative during the construction period. The duties and responsibilities and the limitations of authority of ARCHITECT as OWNER'S representative during construction are set forth in the Contract Documents and shall not be extended without written consent of OWNER and ARCHITECT.

8.2 Visits to Site

OWNER will make visits to the site at intervals appropriate to the various stages of construction to observe the progress and quality of the executed Work and to determine, in general, if the Work is proceeding in accordance with the Contract Documents. OWNER will not be required to make exhaustive or continuous on-site inspections to check the quality or quantity of the Work. OWNER'S efforts will be directed toward providing for OWNER a greater degree of confidence that the completed Work will conform to the Contract Documents.

8.3 Project Representation

OWNER will provide an Inspector to assist OWNER in observing the performance of the Work. If OWNER designates another agent to represent OWNER at the site who is not OWNER'S agent or employee, the duties, responsibilities and limitations of authority of such other person will be as provided in the Special Conditions.

8.4 Clarifications and Interpretations

OWNER will issue with reasonable promptness such written clarifications or interpretations of the requirements of the Contract Documents (in the form of Drawings or otherwise) as OWNER may determine necessary, which shall be consistent with or reasonably inferable from the overall intent of the Contract Documents.

8.5 Authorized Variations in Work

OWNER may authorize minor variations in the Work from the requirements of the Contract Documents which do not involve an adjustment in the Contract Price or the Contract Time and are consistent with the overall intent of the Contract Documents. These may be accomplished by a Field Order.

8.6 Rejecting Defective Work

OWNER will have authority to disapprove or reject Work which OWNER believes to be defective, and will also have authority to require special inspection or testing of the Work as provided in paragraph 12.3, whether or not the Work is fabricated, installed or completed.

8.7 Shop Drawings

In connection with OWNER'S responsibility for Shop Drawings and samples, see paragraphs 5.15.1 through 5.16 inclusive.

8.8 Change Orders

In connection with OWNER'S responsibilities as to Change Orders, see Articles 10, 11 and 12.

8.9 Payments

In connection with OWNER'S responsibilities with respect to Applications for Payment, etc., see Article 13.

8.10 Determinations for Unit Prices [NOT USED]

OWNER will determine the actual quantities and classifications of Unit Price Work performed by CONTRACTOR if applicable.

OWNER will review with CONTRACTOR OWNER'S preliminary determinations on such matters before rendering a written decision thereon (by recommendation of an Application for Payment or otherwise).

8.11 Decision on Disputes

OWNER will be the initial interpreter of the requirements of the Contract Documents and judge of the acceptability of the Work thereunder. Claims, disputes and other matters relating to the acceptability of the Work or the interpretation of the requirements of the Contract Documents pertaining to the performance and furnishing of the Work and claims under Articles 10 and 11 in respect of changes in the Contract Price or Contract Time will be referred initially to OWNER in writing with a request for a formal decision in accordance with this paragraph, which OWNER will render in writing within a reasonable time. Written notice of each such claim, dispute and other matter will be delivered to OWNER promptly (but in no event later than thirty days) after the occurrence of the event giving rise thereto, and written supporting data will be submitted to OWNER within sixty days after such occurrence unless OWNER allows an additional period of time to ascertain more accurate data in support of the claim.

8.12 Limitations on OWNER'S Responsibilities

8.12.1 CONTRACTOR, Supplier, or Surety

Neither OWNER'S authority to act under this Article 8 or elsewhere in the Contract Documents nor any decision made by OWNER in good faith either to exercise or not exercise such authority shall give rise to any duty or responsibility of OWNER to CONTRACTOR, any Subcontractor, any Supplier, or any other person or organization performing any of the Work, or to any surety for any of them.

8.12.2 To Evaluate the Work

Whenever in the Contract Documents the terms "as ordered", "as directed", "as required", "as allowed", "as approved" or terms of like effect or import are used, or the adjectives "reasonable", "suitable", "acceptable", "proper", or "satisfactory" or adjectives or like "effect" or "import" are used to describe a requirement, direction, review or judgment of OWNER as to the Work, it is intended that such requirement, direction, review or judgment will be solely to evaluate the Work for compliance with the Contract Documents (unless there is a specific statement indicating otherwise). The use of any such term or adjective shall not be effective to assign OWNER any duty or authority to supervise or direct the furnishing or performance of the Work or any duty or authority to undertake responsibility contrary to the provisions of paragraph 8.12.3 or 8.12.4.

8.12.3 CONTRACTOR'S Means, Methods, Etc.

OWNER will not be responsible for CONTRACTOR'S means, methods, techniques, sequences or procedures of construction, or the safety precautions and programs incident thereto, and OWNER will not be responsible for CONTRACTOR'S failure to perform or furnish the Work in accordance with the Contract Documents.

8.12.4 Acts of Omissions of CONTRACTOR

OWNER will not be responsible for the acts or omissions of CONTRACTOR or of any Subcontractor, any Supplier, or of any other person or organization performing or furnishing any of the Work.

9. CHANGES IN THE WORK

9.1 OWNER May Order Change

Without invalidating the Agreement and without notice to any surety, OWNER may, at any time or from time to time, order additions, deletions or revisions in the Work; these will be authorized by a Change Order. Upon receipt of such notice, CONTRACTOR shall promptly proceed with the Work involved which will be performed under the applicable conditions of the Contract Documents (except as otherwise specifically provided).

9.2 Claims

Claims for an increase or decrease in the Contract Price or an extension or shortening of the Contract Time that should be allowed as a result of a Change Order will be settled as provided for in Article 10 or Article 11.

9.3 Work Not in Contract Documents

CONTRACTOR shall not be entitled to an increase in the Contract Price or an extension of the Contract Time with respect to any Work performed that is not required by the Contract Documents as amended, modified and supplemented as provided in paragraph 3.4, except in the case of an emergency and except in the case of uncovering Work as provided in paragraph 12.3.4.

9.4 Change Orders

OWNER and CONTRACTOR shall execute appropriate Change Orders covering:

9.4.1 changes in the Work which are ordered by OWNER pursuant to paragraph 9.1, are required because of acceptance of defective Work under paragraph 12.7 or corrective defective Work under paragraph 12.8, or are agreed to by the parties;

9.4.2 changes in the Contract Price or Contract Time which are agreed to by the parties; and

9.4.3 changes in the Contract Price or Contract Time which embody the substance of any written decision rendered by OWNER pursuant to paragraph 8.11; provided that, in lieu of executing any such Change Order, an appeal may be taken from any such decision in accordance with the provisions of the Contract Documents and applicable Laws and REGULATIONS, but during any such appeal, CONTRACTOR shall carry

on the Work and adhere to the progress schedule as provided in paragraph 5.16.

9.5 Notice of Change

If notice of any change affecting the general scope of the Work or the provisions of the Contract Documents (including, but not limited to, Contract Price or Contract Time) is required by the provisions of any Bond to be given to a surety, the giving of any such notice will be CONTRACTOR'S responsibility, and the amount of each applicable Bond will be adjusted accordingly.

10. CHANGE OF CONTRACT PRICE

10.1 Total Compensation

The Contract Price constitutes the total compensation (subject to authorized adjustments) payable to CONTRACTOR for performing the Work. All duties, responsibilities and obligations assigned to or undertaken by CONTRACTOR shall be at his expense without change in the Contract Price.

10.2 Claim for Increase or Decrease in Price

The Contract Price may only be changed by a Change Order. Any claim for an increase or decrease in the Contract Price shall be based on written notice delivered by the CONTRACTOR to the OWNER promptly (but in no event later than thirty days) after the occurrence of the event giving rise to the claim and stating the general nature of the claim. Notice of the amount of the claim with supporting data shall be delivered within sixty days after such occurrence (unless OWNER allows an additional period of time to ascertain more accurate data in support of the claim) and shall be accompanied by CONTRACTOR'S written statement that the amount claimed covers all known amounts (direct, indirect, and consequential) to which the CONTRACTOR is entitled as a result of the occurrence of said event.

10.3 Value of Work

The value of any Work covered by a Change Order or of any claim for an increase or decrease in the Contract Price shall be determined in one of the following ways:

10.3.1 Unit Prices

Where the Work involved is covered by unit prices contained in the Contract Documents, by application of unit prices to the quantities of the items involved (subject to the provisions of paragraphs 10.9.1. through 10.9.3, inclusive).

10.3.2 Lump Sum

By mutual acceptance of a lump sum (which may include an allowance for overhead and profit not necessarily in accordance with paragraph 10.6.2.1).

10.3.3 Cost Plus Fee

On the basis of the Cost of the Work (determined as provided in paragraphs 10.4 and 10.5) plus a CONTRACTOR'S fee for overhead and profit (determined as provided in paragraphs 10.6 and 10.7).

10.4 Cost of the Work

The term Cost of the Work means the sum of all costs necessarily incurred and paid by CONTRACTOR in the proper performance of the Work. Except as otherwise may be agreed to in writing by OWNER, such costs shall be in amounts no higher than those prevailing in the locality of the Project; shall include only the following items; and shall not include any of the costs itemized in paragraph 10.5:

10.4.1 Payroll Costs

Payroll costs for employees in the direct employ of CONTRACTOR in the performance of the Work under schedules of job classifications agreed upon by OWNER and CONTRACTOR. Payroll costs for employees not employed full time on the Work shall be apportioned on the basis of their time spent on the Work. Payroll costs shall include, but not be limited to, salaries and wages plus the cost of fringe benefits which shall include social security contributions, unemployment, excise and payroll taxes, workers' or workmen's compensation, health and retirement benefits, bonuses, sick leave, vacation and holiday pay applicable thereto. Such employees shall include superintendents and foremen at the site. The expenses of performing Work after regular working hours, on Saturday, Sunday or legal holidays shall be included in the above to the extent authorized by OWNER.

10.4.2 Materials and Equipment Costs

Cost of all materials and equipment furnished and incorporated in the Work, including costs of transportation and storage thereof, and Suppliers' field services required in connection therewith. All cash discounts shall accrue to CONTRACTOR unless OWNER deposits funds with CONTRACTOR with which to make payments, in which case the cash discounts shall accrue to OWNER. All trade discounts, rebates and refunds and all returns from sale of surplus materials and equipment shall accrue to OWNER, and CONTRACTOR shall make provisions so that they may be obtained.

10.4.3 Subcontractor Costs

Payments made by CONTRACTOR to the Subcontractors for Work performed by Subcontractors. If required by OWNER, CONTRACTOR shall obtain competitive bids from Subcontractors acceptable to CONTRACTOR and shall deliver such bids to OWNER who will then determine which bids will be accepted. If a subcontract provides that the Subcontractor is to be paid on the basis

of Cost of the Work Plus a Fee, the Subcontractor's Cost of the Work shall be determined in the same manner as CONTRACTOR'S Cost of the Work. All subcontracts shall be subject to the other provisions of the Contract Documents insofar as applicable.

10.4.4 Special Consultant Costs

Costs of special consultants (including but not limited to engineers, architects, testing laboratories, surveyors, attorneys and accountants) employed for services specifically related to the Work.

10.4.5 Supplemental Costs

10.4.5.1 The proportion of necessary transportation, travel and subsistence expenses of CONTRACTOR'S employees incurred in discharge of duties connected with the Work.

10.4.5.2 Cost, including transportation and maintenance, of all materials, supplies, equipment, machinery, appliances, office and temporary facilities at the site and hand tools not owned by the workers, which are consumed in the performance of the Work, and cost less market value of such items used but not consumed which remain the property of CONTRACTOR.

10.4.5.3 Rentals of all construction equipment and machinery and the parts thereof whether rented from CONTRACTOR or others in accordance with rental agreements approved by OWNER, and the costs of transportation, loading, unloading, installation, dismantling and removal shall be in accordance with terms of said rental agreements. The rental of any such equipment, machinery or parts shall cease when the use thereof is no longer necessary for the Work.

10.4.5.4 Sales, consumer, use or similar taxes related to the Work, and for which CONTRACTOR is liable, imposed by Laws and Regulations.

10.4.5.5 Deposits lost for causes other than negligence of CONTRACTOR, any Subcontractor or anyone directly or indirectly employed by any of them or for whose acts any of them may be liable, and royalty payments and fees for permits and licenses.

10.4.5.6 Losses and damages (and related expenses), not compensated by insurance or otherwise, to the Work or otherwise sustained by CONTRACTOR in connection with the performance and furnishing of the Work (except losses and damages within the deductible amounts of property insurance established by OWNER), provided they have resulted from causes other than the negligence of CONTRACTOR, any Subcontractor, or anyone directly or indirectly employed by any of them or for whose acts any of them may be liable. Such losses shall include settlements made with the written consent and approval of OWNER. No such losses, damages and expenses shall be included in the Cost of the Work for the purpose of determining CONTRACTOR'S fee. If, however, any such loss or damage requires reconstruction and CONTRACTOR is placed in charge thereof, CONTRACTOR shall be paid a fee proportionate to that stated in paragraph 10.6.2 for services.

10.4.5.7 The cost of utilities, fuel and sanitary facilities at the site.

10.4.5.8 Minor expenses such as telegrams, long distance telephone calls, telephone service at the site, expressage and similar petty cash items in connection with the Work.

10.4.5.9 Cost of premiums for additional Bonds and insurance required because of changes in the Work and premiums for property insurance coverage within the limits of the deductible amounts established by OWNER.

10.5 Not to Be Included in Cost of the Work

The term Cost of the Work shall not include any of the following:

10.5.1 Costs of Officers and Executives

Payroll costs and other compensation of CONTRACTOR'S officers, executives, principals (of partnership and sole proprietorships), general managers, engineers, architects, estimators, attorneys, auditors, accountants, purchasing and contracting agents, expeditors, timekeepers, clerks and other personnel employed by CONTRACTOR whether at the site or in CONTRACTOR'S principal or a branch office for general administration of the Work and not specifically included in the agreed upon schedule of job classifications referred to in paragraph 10.4.1 or specifically covered by paragraph 10.4.4 - all of which are to be considered administrative costs covered by the CONTRACTOR'S fee.

- 10.5.2 Principal Office
Expenses of CONTRACTOR'S principal and branch offices other than CONTRACTOR'S office at the site.
- 10.5.3 Capital Expense
Any part of CONTRACTOR'S capital expenses, including interest on CONTRACTOR'S capital employed for the Work and charges against CONTRACTOR for delinquent payments.
- 10.5.4 Bonds and Insurance
Cost of premiums for all Bonds and for all insurance whether or not CONTRACTOR is required by the Contract Documents to purchase and maintain the same (except for the cost of premiums covered by subparagraph 10.4.5.9 above).
- 10.5.5 Costs Due to Negligence
Costs due to the negligence of CONTRACTOR, any Subcontractor, or anyone directly or indirectly employed by any of them or for whose acts any of them may be liable, including but not limited to, the correction of defective Work, disposal of materials or equipment wrongly supplied and making good any damage to property.
- 10.5.6 Other Costs
Other overhead or general expense costs of any kind and the costs of any item not specifically and expressly included in paragraph 10.4.

10.6 Contractor's Fee

The CONTRACTOR'S Fee allowed to CONTRACTOR for overhead and profit shall be determined as follows:

10.6.1 a mutually acceptable fixed fee; or if none can be agreed upon,

10.6.2 a fee based on the following percentages of the various portions of the Cost of the Work:

10.6.2.1 for costs incurred under paragraphs 10.4.1 and 10.4.2, the CONTRACTOR'S fee shall be fifteen percent;

10.6.2.2 for costs incurred under paragraph 10.4.3, the CONTRACTOR'S fee shall be five percent; and if a subcontract is on the basis of Cost of the Work Plus a fee, the maximum allowable to CONTRACTOR on account of overhead and profit of all Subcontractors shall be fifteen percent;

10.6.2.3 no fee shall be payable on the basis of costs itemized under paragraphs 10.4.4, 10.4.5 and 10.5;

10.6.2.4 the amount of credit to be allowed by CONTRACTOR to OWNER for any such change which results in a net decrease in cost will be the amount of the actual net decrease plus a deduction in CONTRACTOR'S Fee by an amount equal to ten percent of the net decrease; and

10.6.2.5 when both additions and credits are involved in any one change, the adjustment in CONTRACTOR'S fee shall be computed on the basis of the net change in accordance with paragraphs 10.6.2.1 through 10.6.2.4, inclusive.

10.7 Itemized Cost Breakdown

Whenever the cost of any Work is to be determined pursuant to paragraph 10.4 or 10.5, CONTRACTOR will submit in form acceptable to OWNER an itemized cost breakdown together with supporting data.

10.8 Cash Allowances

It is understood that CONTRACTOR has included in the Contract Price all allowances so named in the Contract Documents and shall cause the Work so covered to be done by such Subcontractors or Suppliers and for such sums within the limit of the allowances as may be acceptable to OWNER, CONTRACTOR agrees that:

10.8.1 Materials and Equipment

The allowances include the cost to CONTRACTOR (less any applicable trade discounts) of materials and equipment required by the allowances to be delivered at the site, and all applicable taxes; and

10.8.2 Other Costs

CONTRACTOR'S costs for unloading and handling on the site, labor, installation costs, overhead, profit and other expenses contemplated for the allowances have been included in the Contract Price and not in the allowances. No demand for additional payment on account of any thereof will be valid.

10.8.3 Change Order

Prior to final payment, an appropriate Change Order will be issued as recommended by OWNER to reflect actual amounts due CONTRACTOR on account of Work covered by allowances, and the Contract Price shall be correspondingly adjusted.

10.9 Unit Price Work

10.9.1 General

Where the Contract Documents provide that all or part of the Work is to be Unit Price Work, initially the Contract Price will be deemed to include for all Unit Price Work an amount equal to the sum of the established unit prices for each separately identified item of Unit Price Work times the estimated quantity of each item as indicated in the Agreement. The estimated quantities of items of Unit Price Work are not guaranteed and are solely for the purpose of comparison of Bids and determining an initial Contract Price. Determinations of the actual quantities and classifications of Unit Price Work performed by CONTRACTOR will be made by OWNER in accordance with Paragraph 8.10.

10.9.2 Overhead and Profit

Each unit price will be deemed to include an amount considered by CONTRACTOR to be adequate to cover CONTRACTOR'S overhead and profit for each separately identified item.

10.9.3 Claim for Increase in Unit Price

Where the quantity of any item of Unit Price Work performed by CONTRACTOR differs materially and significantly from the estimated quantity of such item indicated in the Agreement and there is no corresponding adjustment with respect to any other item of Work and if CONTRACTOR believes that CONTRACTOR has incurred additional expense as a result thereof, CONTRACTOR may make a claim for an increase in the Contract Price in accordance with Article 10.

11. CHANGE OF CONTRACT TIME

11.1 Change Order

The Contract Time may only be changed by a Change Order. Any claim for an extension or shortening of the Contract Time shall be based on written notice delivered to OWNER promptly (but in no event later than thirty days) after the occurrence of the event giving rise to the claim and stating the general nature of the claim. Notice of the extent of the claim with supporting data shall be delivered within sixty days after such occurrence (unless OWNER allows an additional period of time to ascertain more accurate data in support of the claim) and shall be accompanied by the claimant's written statement that the adjustment claimed is the entire adjustment to which the claimant has reason to believe it is entitled as a result of the occurrence of said event. All claims for adjustment in the Contract Time shall be determined by OWNER in accordance with paragraph 8.11. No claim for an adjustment in the Contract Time will be valid if not submitted in accordance with the requirements of this paragraph 11.1.

11.2 Justification for Time Extensions

The Contract Time will be extended in an amount equal to time lost due to delays beyond the control of CONTRACTOR if a claim is made therefore as provided in paragraph 11.1. Such delays shall include, but not be limited to, acts or neglect by OWNER or others performing additional work as contemplated by Article 6, or to fires, floods, labor disputes, epidemics, abnormal weather conditions or acts of God.

11.3 Time Limits

All time limits stated in the Contract Documents are of the essence of the Agreement. The provisions of this Article 11 shall not exclude recovery for damages (including but not limited to fees and charges of engineers, architects, attorneys and other professionals and court costs) for delay by either party.

12. WARRANTY AND GUARANTEE; TESTS AND INSPECTIONS; CORRECTION, REMOVAL OR ACCEPTANCE OF DEFECTIVE WORK

12.1 Warranty and Guarantee

CONTRACTOR warrants and guarantees to OWNER that all Work will be in accordance with the Contract Documents and will not be defective. All defective Work, whether or not in place, may be rejected, corrected or accepted as provided in this Article 12.

12.2 Access to Work

OWNER, OWNER'S representatives, testing agencies and governmental agencies with jurisdictional interests will have access to the Work at reasonable times for their observation, inspecting and testing. CONTRACTOR shall provide proper and safe conditions for such access.

12.3 Tests and Inspections

12.3.1 Timely Notice

CONTRACTOR shall give OWNER timely notice of readiness of the Work for all required inspections, tests or approvals.

12.3.2 Requirements and Responsibilities

The OWNER may require such inspection and testing during the course of the Work as he/she deems necessary to ascertain and assure the integrity and acceptable quality of the materials incorporated and the work performed. Inspection presence may be either full-time or intermittent, and neither the presence nor absence at any time of the OWNER or the INSPECTOR shall relieve the CONTRACTOR of sole responsibility for the acceptability and integrity of the Work or any part thereof.

The costs of sampling, testing, and inspection on-site to ascertain acceptability of the Work and materials will be borne by the OWNER except as otherwise provided. The OWNER will select a testing laboratory to perform such sampling and testing. Sampling and/or testing required by the CONTRACTOR or necessitated by failure of Work or materials to meet the above acceptability test shall be at the expense of the CONTRACTOR.

Inspection services may be performed by the employees of the OWNER or by others selected or designated by the OWNER.

Sampling and/or testing required for manufacturing quality and/or process control, for certification that raw mineral materials or manufactured products are the quality specified in the contract, or to assure the acceptability for incorporation into the Work shall be borne by the CONTRACTOR or the material supplier.

Cost for inspection, sampling, testing, and approvals required by the laws or regulations of any public body having competent jurisdiction shall be borne by the CONTRACTOR or the material supplier.

Sampling and testing will be in accord with pertinent codes and regulations and with appropriate standards of the American Society of Testing Materials or other specified standards.

12.3.3 On-Site Construction Test and Other Testing

All inspections, tests or approvals other than those required by Laws or Regulations of any public body having jurisdiction shall be performed by organizations acceptable to OWNER and CONTRACTOR.

12.3.4 Covered Work

If any Work (including the work of others) that is to be inspected, tested or approved is covered without written concurrence of OWNER, it must, if requested by OWNER, be uncovered for observation. Such uncovering shall be at CONTRACTOR'S expense unless CONTRACTOR has given OWNER timely notice of CONTRACTOR'S intention to cover the same and OWNER has not acted with reasonable promptness in response to such notice.

12.3.5 CONTRACTOR'S Obligation

Neither observations by OWNER nor inspections, tests or approvals by others shall relieve CONTRACTOR from CONTRACTOR'S obligations to perform the Work in accordance with the Contract Documents.

12.4 OWNER May Stop the Work

If the Work is defective, or CONTRACTOR fails to supply sufficient skilled workers or suitable materials or equipment, or fails to furnish or perform the Work in such a way that the completed Work will conform to the Contract Documents, OWNER may order CONTRACTOR to stop the Work, or any portion thereof, until the cause for such order has been eliminated; however, this right of OWNER to stop the Work shall not give rise to any duty on the part of OWNER to exercise this right for the benefit of CONTRACTOR or any other party.

12.5 Correction or Removal of Defective Work

If required by OWNER, CONTRACTOR shall promptly, as directed, either correct all defective Work, whether or not fabricated, installed or completed, or, if the Work has been rejected by OWNER, remove it from the site and replace it with non-defective Work. CONTRACTOR shall bear all direct, indirect and consequential costs of such correction or removal (including but not limited to fees and charges of engineers, architects, attorneys and other professionals) made necessary thereby.

12.6 One Year Correction Period

If within one year after the date of Completion or such longer period of time as may be prescribed by Laws or Regulations or by the terms of any applicable special guarantee required by the Contract Documents or by any specific provision of the Contract Documents, any Work is found to be defective, CONTRACTOR shall promptly, without cost to OWNER and in accordance with OWNER'S written instructions, either correct such defective Work, or, if it has been rejected by OWNER, remove it from the site and replace it with non-defective Work. If CONTRACTOR does not promptly comply with the terms of such instructions, or in an emergency where delay would cause serious risk of loss or damage, OWNER may have the defective Work corrected or the rejected Work removed and replaced, and all direct, indirect and consequential costs of such removal and replacement (including but not limited to fees and charges of engineers, architects, attorneys and other professionals) will be paid by CONTRACTOR. In special circumstances where a particular item of equipment is placed in continuous service before

Completion of all the Work, the correction period for that item may start to run from an earlier date if so provided in the Specifications or by Change Order.

12.7 Acceptance of Defective Work

If, instead of requiring correction or removal and replacement of defective Work, OWNER prefers to accept it, OWNER may do so. CONTRACTOR shall bear all direct, indirect and consequential costs attributable to OWNER'S evaluation of and determination to accept such defective Work (such costs to be approved by OWNER as to reasonableness and to include but not be limited to fees and charges of engineers, architects, attorneys and other professionals).

12.8 OWNER May Correct Defective Work

If CONTRACTOR fails within a reasonable time after written notice of OWNER to proceed to correct and to correct defective Work or to remove and replace rejected Work as required by OWNER in accordance with paragraph 12.5, or if CONTRACTOR fails to perform the Work in accordance with the Contract Documents, or if CONTRACTOR fails to comply with any other provision of the Contract Documents, OWNER may, after seven days' written notice to CONTRACTOR, correct and remedy any such deficiency. In exercising the rights and remedies under this paragraph OWNER shall proceed expeditiously. To the extent necessary to complete corrective and remedial action, OWNER may exclude CONTRACTOR from all or part of the site, take possession of all or part of the Work, and suspend CONTRACTOR'S services related thereto, take possession of CONTRACTOR'S tools, appliances, construction equipment and machinery at the site and incorporate in the Work all materials and equipment stored at the site or for which OWNER has paid CONTRACTOR but which are stored elsewhere. CONTRACTOR shall allow OWNER, OWNER'S representatives, agents and employees such access to the site as may be necessary to enable OWNER to exercise the rights and remedies under this paragraph. All direct, indirect and consequential costs of OWNER in exercising such rights and remedies will be charged against CONTRACTOR in an amount approved as to reasonableness by OWNER, and a Change Order will be issued incorporating the necessary revisions in the Contract Documents with respect to the Work; and OWNER shall be entitled to an appropriate decrease in the Contract Price. Such direct, indirect and consequential costs will include but not be limited to fees and charges of engineers, architects, attorneys and other professionals, all court costs and all costs of repair and replacement of work of others destroyed or damaged by correction, removal or replacement of CONTRACTOR'S defective Work. CONTRACTOR shall not be allowed an extension of the Contract Time because of any delay in performance of the Work attributable to the exercise by OWNER of OWNER'S rights and remedies hereunder.

13. PAYMENTS TO CONTRACTOR AND COMPLETION

13.1 Schedule of Values

The schedule of values established as provided in paragraph 2.8 will serve as the basis for progress payments and will be incorporated into a form of Application for Payment acceptable to OWNER. Progress payments on account of Unit Price Work will be based on the number of units completed.

13.2 Application for Progress Payment

At least ten days before each progress payment is scheduled (but not more often than once a month), CONTRACTOR shall submit to OWNER for review an Application for Payment filled out and signed by CONTRACTOR covering the Work completed as of the date of the Application and accompanied by such supporting documentation as is required by the Contract Documents. If payment is requested on the basis of materials and equipment not incorporated in the Work but delivered and suitably stored at the site or at another location agreed to in writing, the Application for Payment shall also be accompanied by a bill of sale, invoice or other documentation warranting that OWNER has received the materials and equipment free and clear of all liens, charges, security interests and encumbrances (which are hereinafter in these General Conditions referred to as "Liens") and evidence that the materials and equipment are covered by appropriate property insurance and other arrangements to protect OWNER'S interest therein, all of which will be satisfactory to OWNER. OWNER shall, within thirty (30) calendar days of presentation to him of an approved Application for Payment, pay CONTRACTOR the amount approved by OWNER. Monthly progress payments shall be ninety (90) percent of the sum obtained by applying the respective bid unit prices to the approved estimated quantities of work completed by the Contractor during the preceding month. The remaining ten (10) percent will be held by the Owner, as retainage. At such time as the OWNER deems appropriate - based on the quality of work performed, progress of cleanup, and other pertinent factors - the rate of retainage, or the total amount retained, may be reduced; although, any reduction in retainage, below the ten (10) percent level, is made solely at the OWNER'S discretion. All remaining retainage held will be included in the final payment to the Contractor.

13.3 CONTRACTOR'S Warranty of Title

CONTRACTOR warrants and guarantees that title to all Work, materials and equipment covered by any Application for Payment, whether incorporated in the Project or not, will pass to OWNER no later than the time of payment free and clear of all Liens.

13.4 Review of Applications for Progress Payment

13.4.1 Submission of Application for Payment

OWNER will, after receipt of each Application for Payment, either indicate in writing a recommendation of payment and present the Application to OWNER, or return the Application to CONTRACTOR indicating in writing OWNER'S reasons for refusing to recommend payment. In the latter case, CONTRACTOR may make the necessary corrections and resubmit the Application.

13.4.2 OWNER'S Recommendation

OWNER may refuse to recommend the whole or any part of any payment, if, in OWNER'S opinion, it would be incorrect to make such representations to OWNER. OWNER may also refuse to recommend any such payment, or, because of subsequently discovered evidence or the results of subsequent inspections or tests, nullify any such payment previously recommended, to such extent as may be necessary in OWNER'S opinion to protect OWNER from loss because:

13.4.2.1 the Work is defective, or completed Work has been damaged requiring correction or replacement;

13.4.2.2 the Contract Price has been reduced by Written Amendment or Change Order;

13.4.2.3 OWNER has been required to correct defective Work or complete Work in accordance with paragraph 12.8; or

13.4.2.4 of OWNER'S actual knowledge of the occurrence of any of the events enumerated in paragraphs 14.2.1 through 14.2.9 inclusive.

13.5 Partial Utilization

OWNER at any time may request CONTRACTOR in writing to permit OWNER to use any such part of the Work which OWNER believes to be ready for its intended use and has been completed. If CONTRACTOR agrees, CONTRACTOR will certify to OWNER that said part of the Work is complete and request that a Certificate of Completion be issued for that part of the Work.

13.6 Final Inspection

Upon written notice from CONTRACTOR that the entire Work or an agreed portion thereof is complete, OWNER will make a final inspection with CONTRACTOR and will notify CONTRACTOR in writing of all particulars in which this inspection reveals that the Work is incomplete or defective. CONTRACTOR shall immediately take such measures as are necessary to remedy such deficiencies.

13.7 Final Application for Payment

After CONTRACTOR has completed all such corrections to the satisfaction of OWNER and delivered all maintenance and operating instructions, schedules, guarantees, Bonds, certificates of inspection, marked-up record documents (as provided in paragraph 5.14) and other documents - all as required by the Contract Documents, and after OWNER has indicated that the Work is acceptable (subject to the provisions of paragraph 13.10), CONTRACTOR may make application for final payment following the procedure for progress payments. The final Application for Payment shall be accompanied by all documentation called for in the Contract Documents, together with complete and legally effective releases or waivers (satisfactory to OWNER) of all Liens arising out of or filed in connection with the Work. In lieu thereof and as approved by OWNER, CONTRACTOR may furnish receipts or releases in full; an affidavit of CONTRACTOR that the releases and receipts include all labor, services, material and equipment for which a Lien could be filed, and that all payrolls, material and equipment bills, and other indebtedness connected with the Work for which OWNER or OWNER'S property might in any way be responsible, have been paid or otherwise satisfied; and consent of the surety, if any, to final payment. If any Subcontractor or Supplier fails to furnish a release or receipt in full, CONTRACTOR may furnish a Bond or other collateral satisfactory to OWNER to indemnify OWNER against any Lien.

13.8 Final Payment and Acceptance

13.8.1 OWNER'S Approval

If, on the basis of OWNER'S observation of the Work during construction and final inspection, and OWNER'S review of the final Application for Payment and accompanying documentation - all as required by the Contract Documents, OWNER is satisfied that the Work has been completed and CONTRACTOR'S other obligations under the Contract Documents have been fulfilled, OWNER will, after receipt of the final Application for Payment, indicate in writing OWNER'S recommendation of payment and present the Application to OWNER for payment. Thereupon OWNER will give written notice to OWNER and CONTRACTOR that the Work is acceptable, subject to the provisions of paragraph 13.10. Otherwise, OWNER will return the Application to CONTRACTOR, indicating in writing the reasons for refusing to recommend final payment, in which case CONTRACTOR shall make the necessary corrections and resubmit the Application.

13.8.2 Delay in Completion of Work

If, through no fault of CONTRACTOR, final completion of the Work is significantly delayed, OWNER shall, upon receipt of CONTRACTOR'S final Application for Payment and recommendation of OWNER, and without terminating the Agreement, make payment of the balance due for that portion of the Work fully completed and accepted. If the remaining balance to be held by OWNER for Work not fully completed or corrected is

less than the retainage stipulated in the Agreement, and if Bonds have been furnished as required in paragraph 10 of Part II, Information for Bidders, the written consent of the surety to the payment of the balance due for that portion of the Work fully completed and accepted shall be submitted by CONTRACTOR to OWNER with the Application for such payment. Such payment shall be made under the terms and conditions governing final payment, except that it shall not constitute a waiver of claims.

13.9 CONTRACTOR'S Continuing Obligation

CONTRACTOR'S obligation to perform and complete the Work in accordance with the Contract Documents shall be absolute. Neither recommendation of any progress or final payment by OWNER, nor the issuance of a certificate of Completion, nor any payment by OWNER to CONTRACTOR under the Contract Documents, nor any use or occupancy of the Work or any part thereof by OWNER, nor any act of acceptance by OWNER nor any failure to do so, nor any review and approval of a Shop Drawing or sample submission, nor any correction of defective Work by OWNER will constitute an acceptance of Work not in accordance with the Contract Documents or a release of CONTRACTOR'S obligation to perform the Work in accordance with the Contract Documents (except as provided in paragraph 13.10).

13.10 Waiver of Claims

The making and acceptance of final payment will constitute:

13.10.1 a waiver of all claims by OWNER against CONTRACTOR, except claims arising from unsettled Liens, from defective Work appearing after final inspection or from failure to comply with the Contract Documents or the terms of any special guarantees specified therein; however, it will not constitute a waiver by OWNER of any rights in respect of CONTRACTOR'S continuing obligations under the Contract Documents; and

13.10.2 a waiver of all claims by CONTRACTOR against OWNER other than those previously made in writing and still unsettled.

14. SUSPENSION OF WORK AND TERMINATION

14.1 OWNER May Suspend Work

OWNER may, at any time and without cause, suspend the Work or any portion thereof for a period of not more than ninety days by notice in writing to CONTRACTOR which will fix the date on which Work will be resumed. CONTRACTOR shall resume the Work on the date so fixed. CONTRACTOR shall be allowed an increase in the Contract Price or an extension of the Contract Time, or both, directly attributable to any suspension if CONTRACTOR makes an approved claim therefore as provided in Articles 10 and 11.

14.2 OWNER May Terminate

The OWNER may terminate the Work upon the occurrence of any one or more of the following events:

14.2.1 if CONTRACTOR commences a voluntary case under any chapter of the Bankruptcy Code (Title 11, United States Code), as now or hereafter in effect, or if CONTRACTOR takes any equivalent or similar action by filing a petition or otherwise under any other federal or state law in effect at such time relating to the bankruptcy or insolvency;

14.2.2 if a petition is filed against CONTRACTOR under any chapter of the Bankruptcy Code as now or hereafter in effect at the time of filing, or if a petition is filed seeking any such equivalent or similar relief against CONTRACTOR under any other federal or state law in effect at the time relating to bankruptcy or insolvency;

14.2.3 if CONTRACTOR makes a general assignment for the benefit of creditors;

14.2.4 if a trustee, receiver, custodian or agent of CONTRACTOR is appointed under applicable law or under contract, whose appointment or authority to take charge of property of CONTRACTOR is for the purpose of enforcing a Lien against such property or for the purpose of general administration of such property for the benefit of CONTRACTOR'S creditors;

14.2.5 if CONTRACTOR admits in writing an inability to pay its debts generally as they become due;

14.2.6 if CONTRACTOR persistently fails to perform the Work in accordance with the Contract Documents (including, but not limited to, failure to supply sufficient skilled workers or suitable materials or equipment or failure to adhere to the progress schedule established under paragraph 2.8 as revised from time to time);

14.2.7 if CONTRACTOR disregards Laws or Regulations of any public body having jurisdiction;

14.2.8 if CONTRACTOR disregards the authority of OWNER, or

14.2.9 if CONTRACTOR otherwise violates in any substantial way any provisions of the Contract Documents;

OWNER may, after giving CONTRACTOR (and the surety) seven days' written notice and to the extent permitted by Laws and Regulations, terminate the services of CONTRACTOR, exclude CONTRACTOR from

the site and take possession of the Work and of all CONTRACTOR'S tools, appliances, construction equipment and machinery at the site and use the same to the full extent they could be used by CONTRACTOR (without liability to CONTRACTOR for trespass or conversion), incorporate in the Work all materials and equipment stored at the site or for which OWNER has paid CONTRACTOR but which are stored elsewhere, and finish the Work as OWNER may deem expedient. In such case CONTRACTOR shall not be entitled to receive any further payment until the Work is finished. If the unpaid balance of the Contract Price exceeds the direct, indirect and consequential costs of completing the Work (including but not limited to fees and charges of engineers, architects, attorneys and other professionals and court and arbitration costs) such excess will be paid to CONTRACTOR. If such costs exceed such unpaid balance, CONTRACTOR shall pay the difference to OWNER. Such costs incurred by OWNER will be approved as to reasonableness by OWNER and incorporated in a Change Order, but when exercising any rights or remedies under this paragraph OWNER shall not be required to obtain the lowest price for the Work performed.

14.2.10 If safety violations are observed and brought to the Contractors attention and Contractor fails to take immediate corrective measures any repeat of similar safety violations, Owner will order an immediate termination of contract. Note: it is the Contractor's responsibility to know proper safety measures as they pertain to construction and OSHA.

14.2.11 This contract may be canceled by either party thirty (30) days after delivery by canceling party of written notice of intent to cancel to the other contracting party.

14.2.12 This contract may be canceled by the Lexington-Fayette Urban County Government if it is determined that the Bidder has failed to perform under the terms of this agreement, such cancellation to be effective upon receipt of written notice of cancellation by the Bidder.

14.3 CONTRACTOR'S Services Terminated

Where CONTRACTOR'S services have been so terminated by OWNER, the termination will not affect any rights or remedies of OWNER against CONTRACTOR then existing or which may thereafter accrue. Any retention or payment of moneys due CONTRACTOR by OWNER will not release CONTRACTOR from liability.

14.4 Payment After Termination

Upon seven days' written notice to CONTRACTOR, OWNER may, without cause and without prejudice to any other right or remedy, elect to abandon the Work and terminate the Agreement. In such case, CONTRACTOR shall be paid for all Work executed and any expense sustained plus reasonable termination expenses, which will include, but not be limited to, direct, indirect and consequential costs (including,

but not limited to, fees and charges of engineers, architects, attorneys and other professionals and court and arbitration costs).

14.5 CONTRACTOR May Stop Work or Terminate

If, through no act or fault of CONTRACTOR, the Work is suspended for a period of more than ninety days by OWNER or under an order of court or other public authority, or OWNER fails to act on any Application for Payment within sixty days after it is submitted, or OWNER fails for sixty days to pay CONTRACTOR any sum finally determined to be due, then CONTRACTOR may, upon seven days' written notice to OWNER, terminate the Agreement and recover from OWNER payment for all Work executed and any expense sustained plus reasonable termination expenses. In addition and in lieu of terminating the Agreement, if OWNER has failed to act on an Application for Payment or OWNER has failed to make any payment as aforesaid, CONTRACTOR may upon seven days' written notice to OWNER stop the Work until payment of all amounts then due. The provisions of this paragraph shall not relieve CONTRACTOR of the obligations under paragraph 5.16 to carry on the Work in accordance with the progress schedule and without delay during disputes and disagreements with OWNER.

15. MISCELLANEOUS

15.1 Claims for Injury or Damage

Should OWNER or CONTRACTOR suffer injury or damage to person or property because of any error, omission or act of the other party or of any of the other party's employees or agents or others for whose acts the other party is legally liable, claim will be made in writing to the other party within a reasonable time of the first observance of such injury or damage. The provisions of this paragraph 15.1 shall not be construed as a substitute for or a waiver of the provisions of any applicable statute of limitations or repose.

15.2 Non-Discrimination in Employment

The CONTRACTOR shall comply with the following requirements prohibiting discrimination:

15.2.1 That no person (as defined in KRS 344.010) shall bid on Lexington-Fayette Urban County Government construction projects, or bid to furnish materials or supplies to the Lexington-Fayette Urban County Government, if, within six months prior to the time of opening of bids, said person shall have been found, by declamatory judgment action in Fayette Circuit Court, to be presently engaging in an unlawful practice, as hereinafter defined. Such declamatory judgment action may be brought by an aggrieved individual or upon an allegation that an effort at conciliation pursuant to KRS 344.200 has been attempted and failed, by the Lexington-Fayette County Human Rights Commission.

15.2.2 That it is an unlawful practice for an employer:

15.2.2.1 to fail or refuse to hire, or to discharge any individual or otherwise to discriminate against an individual, with respect to his compensation, terms, conditions, or privileges of employment, because of such individual's race, color, religion, sex, age, or national origin; or

15.2.2.2 to limit, segregate or classify his employees in any way which would deprive or tend to deprive an individual of employment opportunities or otherwise adversely affect his status as an employee because of such individual's sex, race, color, religion, age, or national origin.

15.2.3 That it is an unlawful practice for an employer, labor organization, or joint-labor management committee controlling apprenticeship or other training or retraining, including on-the-job training programs to discriminate against an individual because of his race, color, religion, sex, age, or national origin in admission to, or employment in, any program established to provide apprenticeship or other training.

15.2.4 That a copy of this Ordinance shall be furnished all suppliers and made a part of all bid specifications.

15.2.5 This Ordinance shall take effect after it is signed, published and recorded, as required by law.

15.3 Temporary Street Closing or Blockage

The CONTRACTOR will notify the OWNER at least 72 hours prior to making any temporary street closing or blockage. This will permit orderly notification to all concerned public agencies. Specific details and restrictions on street closure or blockage are contained in the Special Conditions.

15.4 Percentage of Work Performed by prime CONTRACTOR

The CONTRACTOR shall perform on site, and with its own organization, Work equivalent to at least fifty (50%) percent of the total amount of Work to be performed under the Contract. This percentage may be reduced by a supplemental agreement to this Contract if, during performing the Work, the CONTRACTOR requests a reduction and the OWNER determines that the reduction would be to the advantage of the OWNER.

15.5 Clean-up

Cleanup shall progress, to the greatest degree practicable, throughout the course of the Work. The Work will not be considered as completed, and final payment will not be made, until the right-of-way and all ground occupied or affected by the Contractor in connection with the Work has been cleared of all rubbish, equipment,

excess materials, temporary structures, and weeds. Rubbish and all waste materials of whatever nature shall be disposed of, off of the project site, in an acceptable manner. All property, both public and private, which has been damaged in the prosecution of the Work, shall be restored in an acceptable manner. All areas shall be draining, and all drainage ways shall be left unobstructed, and in such a condition that drift will not collect or scour be induced.

15.6 General

The duties and obligations imposed by these General Conditions and the rights and remedies available hereunder to the parties hereto, and, in particular but without limitation, the warranties, guarantees and obligations imposed upon CONTRACTOR by paragraphs 12.1, 12.3.5, 13.3, and 15.2 and all of the rights and remedies available to OWNER thereunder, are in addition to, and are not to be construed in any way as a limitation of, any rights and remedies available to any or all of them which are otherwise imposed or available by Laws or Regulations, by special warranty or guarantee or by other provisions of the Contract Documents, and the provisions of this paragraph will be as effective as if repeated specifically in the Contract Documents in connection with each particular duty, obligation, right and remedy to which they apply. All representations, warranties and guarantees made in the Contract Documents will survive final payment and termination or completion of the Agreement.

15.7 Debris Disposal

For all LFUCG projects any trash, construction demolition debris, yard waste, dirt or debris of any kind that is removed from the project site must be disposed of in accordance with local, state, and federal regulations. The disposal site or facility must be approved in advance by the LFUCG and disposal documentation is required. The Contractor will be responsible for payment of any fines associated with improper disposal of material removed from the project site.

15.8 Close Out Procedures

The CONTRACTOR will coordinate training for OWNER of all major building systems and equipment that are part of the Project.

The CONTRACTOR will distribute three (3) copies of the appropriate O&M Manuals for the installed major building systems and equipment.

The CONTRACTOR shall prepare accurate record drawings that reflect project improvements "as-built" in the field. The CONTRACTOR shall provide three (3) copies of the record drawings to the OWNER.

The CONTRACTOR shall provide an electronic version (AutoCAD) of all construction documents related to the Project at the conclusion of the Project.

END OF SECTION

PART V
SPECIAL CONDITIONS
INDEX

1 RISK MANAGEMENT PROVISIONS –
INSURANCE AND INDEMNIFICATION..... SC-2

**RISK MANAGEMENT PROVISIONS
INSURANCE AND INDEMNIFICATION**

INDEMNIFICATION AND HOLD HARMLESS PROVISION

- (1) It is understood and agreed by the parties that Contractor hereby assumes the entire responsibility and liability for any and all damages to persons or property caused by or resulting from or arising out of any act or omission on the part of Contractor or its employees, agents, servants, owners, principals, licensees, assigns or subcontractors of any tier (hereinafter "CONTRACTOR") under or in connection with this agreement and/or the provision of goods or services and the performance or failure to perform any work required thereby.
- (2) CONTRACTOR shall indemnify, save, hold harmless and defend the Lexington-Fayette Urban County Government and its elected and appointed officials, employees, agents, volunteers, and successors in interest (hereinafter "LFUCG") from and against all liability, damages, and losses, including but not limited to, demands, claims, obligations, causes of action, judgments, penalties, fines, liens, costs, expenses, interest, defense costs and reasonable attorney's fees that are in any way incidental to or connected with, or that arise or are alleged to have arisen, directly or indirectly, from or by CONTRACTOR's performance or breach of the agreement and/or the provision of goods or services provided that: (a) it is attributable to personal injury, bodily injury, sickness, or death, or to injury to or destruction of property (including the loss of use resulting therefrom), or to or from the negligent acts, errors or omissions or willful misconduct of the CONTRACTOR; and (b) not caused solely by the active negligence or willful misconduct of LFUCG.
- (3) In the event LFUCG is alleged to be liable based upon the above, CONTRACTOR shall defend such allegations and shall bear all costs, fees and expenses of such defense, including but not limited to, all reasonable attorneys' fees and expenses, court costs, and expert witness fees and expenses, using attorneys approved in writing by LFUCG, which approval shall not be unreasonably withheld.
- (4) These provisions shall in no way be limited by any financial responsibility or insurance requirements, and shall survive the termination of this agreement.

FINANCIAL RESPONSIBILITY

BIDDER/CONTRACTOR understands and agrees that it shall, prior to final acceptance of its bid and the commencement of any work, demonstrate the ability to assure compliance with the above Indemnity provisions and these other risk management provisions.

INSURANCE REQUIREMENTS

YOUR ATTENTION IS DIRECTED TO THE INSURANCE REQUIREMENTS BELOW, AAND YOU MAY NEED TO CONFER WITH YOUR INSURANCE AGENTS, BROKERS, OR CARRIERS TO DETERMINE IN ADVANCE OF SUBMISSION OF A RESPONSE THE AVAILABILITY OF THE INSURANCE COVERAGES AND ENDORSEMENTS REQUIRED

HEREIN. IF YOU FAIL TO COMPLY WITH THE INSURANCE REQUIREMENTS BELOW, YOU MAY BE DISQUALIFIED FROM AWARD OF THE CONTRACT.

Required Insurance Coverage

BIDDER/CONTRACTOR shall procure and maintain for the duration of this contract the following or equivalent insurance policies at no less than the limits shown below and cause its subcontractors to maintain similar insurance with limits acceptable to LFUCG in order to protect LFUCG against claims for injuries to persons or damages to property which may arise from or in connection with the performance of the work hereunder by CONTRACTOR. The cost of such insurance shall be included in any bid:

<u>Coverage</u>	<u>Limits</u>
General Liability aggregate (Insurance Services Office Form CG 00 01)	\$1 million per occurrence, \$2 million aggregate or \$2 million combined single limit
Commercial Automobile Liability occurrence (Insurance Services Office Form CA 0001)	combined single, \$1 million per occurrence
Worker's Compensation	Statutory
Employer's Liability	\$500,000.00

The policies above shall contain the following conditions:

- a. All Certificates of Insurance forms used by the insurance carrier shall be properly filed and approved by the Department of Insurance for the Commonwealth of Kentucky (DOI). LFUCG shall be named as an additional insured in the General Liability Policy and Commercial Automobile Liability Policy using the Kentucky DOI approved forms.
- b. The General Liability Policy shall be primary to any insurance or self-insurance retained by LFUCG.
- c. The General Liability Policy shall include a Products and Completed Operations endorsement and the General Liability Policy shall contain a Product Liability endorsement or separate coverage, with the same limits as the General Liability policy.
- d. LFUCG shall be provided at least 30 days advance written notice via certified mail, return receipt requested, in the event any of the required policies are canceled or non-renewed.
- e. Said coverage shall be written by insurers acceptable to LFUCG and shall be in a form acceptable to LFUCG. Insurance placed with insurers with a rating classification of no less than Excellent (A or A-) and a financial size category of no less than VIII, as

defined by the most current Best's Key Rating Guide shall be deemed automatically acceptable.

Renewals

After insurance has been approved by LFUCG, evidence of renewal of an expiring policy must be submitted to LFUCG, and may be submitted on a manually signed renewal endorsement form. If the policy or carrier has changed, however, new evidence of coverage must be submitted in accordance with these Insurance Requirements.

Deductibles and Self-Insured Programs

IF YOU INTEND TO SUBMIT A SELF-INSURANCE PLAN IT MUST BE FORWARDED TO LEXINGTON-FAYETTE URBAN COUNTY GOVERNMENT, DIVISION OF RISK MANAGEMENT, 200 EAST MAIN STREET, LEXINGTON, KENTUCKY 40507 NO LATER THAN A MINIMUM OF FIVE (5) WORKING DAYS PRIOR TO THE RESPONSE

DATE. Self-insurance programs, deductibles, and self-insured retentions in insurance policies are subject to separate approval by Lexington-Fayette Urban County Government's Division of Risk Management, upon review of evidence of BIDDER/CONTRACTOR's financial capacity to respond to claims. Any such programs or retentions must provide LFUCG with at least the same protection from liability and defense of suits as would be afforded by first-dollar insurance coverage. If BIDDER/CONTRACTOR satisfies any portion of the insurance requirements through deductibles, self-insurance programs, or self-insured retentions, BIDDER/CONTRACTOR agrees to provide Lexington-Fayette Urban County Government, Division of Risk Management, the following data prior to the final acceptance of bid and the commencement of any work:

- a. Latest audited financial statement, including auditor's notes.
- b. Any records of any self-insured trust fund plan or policy and related accounting statements.
- c. Actuarial funding reports or retained losses.
- d. Risk Management Manual or a description of the self-insurance and risk management program.
- e. A claim loss run summary for the previous five (5) years.
- f. Self-Insured Associations will be considered.

Safety and Loss Control

CONTRACTOR shall comply with all applicable federal, state, and local safety standards related to the performance of its works or services under this Agreement and take necessary action to protect the life, health and safety and property of all of its personnel on the job site, the public, and LFUCG.

Verification of Coverage

BIDDER/CONTRACTOR agrees to furnish LFUCG with all applicable Certificates of Insurance signed by a person authorized by the insurer to bind coverage on its behalf prior to final award, and if requested, shall provide LFUCG copies of all insurance policies, including all endorsements.

Right to Review, Audit and Inspect

CONTRACTOR understands and agrees that LFUCG may review, audit and inspect any and all of its records and operations to insure compliance with these Insurance Requirements.

DEFAULT

BIDDER/CONTRACTOR understands and agrees that the failure to comply with any of these insurance, safety, or loss control provisions shall constitute default and that LFUCG may elect at its option any single remedy or penalty or any combination of remedies and penalties, as available, including but not limited to purchasing insurance and charging BIDDER/CONTRACTOR for any such insurance premiums purchased, or suspending or terminating the work.

00378691

PART VI

CONTRACT AGREEMENT

INDEX

1.	SCOPE OF WORK.....	CA-2
2.	TIME OF COMPLETION.....	CA-2
3.	ISSUANCE OF WORK ORDERS.....	CA-2
4.	THE CONTRACT SUM.....	CA-2
5.	PROGRESS PAYMENTS.....	CA-3
6.	ACCEPTANCE AND FINAL PAYMENT.....	CA-3
7.	THE CONTRACT DOCUMENTS.....	CA-3
8.	EXTRA WORK.....	CA-3
9.	ENUMERATION OF SPECIFICATIONS AND DRAWINGS.....	CA-4

5. PROGRESS PAYMENTS

The OWNER shall make payments on account of the Contract, as provided in accordance with the General Conditions, as estimated by the Owner, less the aggregate of previous payments.

6. ACCEPTANCE AND FINAL PAYMENT

Final payment shall be due within ninety (90) days after completion of the Work, provided the Work be then fully completed and the Contract fully accepted.

Before issuance of final certificate, the CONTRACTOR shall submit evidence satisfactory to the Engineer that all payrolls, material bills, and other indebtedness connected with the Work has been paid.

If, after the Work has been substantially completed, full completion thereof is materially delayed through no fault of the CONTRACTOR and the OWNER so certifies, the OWNER shall, and without terminating the Contract, make payment of the balance due for that portion of the Work fully completed and accepted. Such payment shall be made under the terms and conditions governing final payment, except that it shall not constitute a waiver of claims.

7. THE CONTRACT DOCUMENTS

The Advertisement for Bids, Information for Bidders, the General Conditions, Performance and Payment Bonds, Contract Agreement, Special Conditions, Technical Specifications, any and all Addenda, and Proposal, and Plan Drawings form the Contract, and they are fully a part of the Contract as if hereto attached or herein repeated.

8. EXTRA WORK

The OWNER, without invalidating the Contract, may order extra work or make changes by altering, adding to or deducting from the Work, the Contract Sum being adjusted accordingly. All such Work shall be executed and paid for in accordance with the General Conditions, which is a part of this Contract.

9. THE FOLLOWING IS AN ENUMERATION OF THE SPECIFICATIONS AND DRAWINGS (CONTRACT DOCUMENTS):

SPECIFICATIONS

SECTION NO.	TITLE	PAGES
I	Advertisement for Bids	AB 1 thru 4
II	Information for Bidders	IB 1 thru 15
III	Form of Proposal	P 1 thru 3128
IV	General Conditions	GC 1 thru 50
V	Special Conditions	SC 1 thru 5
VI	Contract Agreement	CA 1 thru 5
VII	Performance and Payment Bonds	PB 1 thru 7
VIII	Addenda	AD 1 thru 1
IX		

Technical Specifications **TECHNICAL SPECIFICATIONS**

- 02610 – Concrete
- 02711 – Chain Link Dugouts, Roof, Fences, Gates
- 02870 – Site Specialties (Team Bench)
- 02920 – Seeding

PLAN DRAWINGS

- Sheet 1 – Typical Layout and Details
- Sheet 2 – Site Plan: Castlewood Park Baseball Field
- Sheet 3 – Site Plan: Castlewood Park Softball Field
- Sheet 4 – Site Plan: Woodland Park Softball Field
- Sheet 5 – Site Plan: Kirklevington Park Softball Field
- Sheet 6 – Site Plan: Wolf Run Park Field

IN WITNESSETH WHEREOF, the parties hereto have executed this Contract as of the date and year above written.

(Seal)

Lexington-Fayette Urban County Government.

Lexington, Kentucky

(Owner)

ATTEST:

Meredith Nelson, Deputy
Clerk of the Urban County Council

BY: Jim Gray

MAYOR

Debbie Oester
(Witness)

(Title)

(Seal)

Rio Grande Fence Company

(Contractor)

Michael Tuelley
(Secretary)*

BY: Frank [Signature]

President

(Title)

Carl [Signature]
(Witness)

1375 Forbes Road
Lexington, KY 40511

(Address and Zip Code)

IMPORTANT: *Strike out any non-applicable terms.

Secretary of the Owner should attest. If the CONTRACTOR is corporation, Secretary should attest. Give proper title of each person-executing Contract.

PART VII

PERFORMANCE AND PAYMENT BONDS

1. PERFORMANCE BOND
2. PAYMENT BOND



The Ohio Casualty Insurance Company

Performance Bond

601059662

KNOW ALL MEN BY THESE PRESENTS,

That we Rio Grande Fence Company, Inc., as Principal,
 (hereinafter called Principal) and The Ohio Casualty Insurance Company, with principal offices in Keene,
 New Hampshire as Surety, (hereinafter called Surety) are held and firmly bound unto
Lexington-Fayette Urban County Government
 as Oblige, (hereinafter called Oblige), in the amount of
One hundred forty-eight thousand, eight hundred thirty-one Dollars \$ 148,831.00
 for payment of which sum well and truly to be made, we bind ourselves, our heirs, executors, administrators, successors and assigns
 firmly by these presents.

WHEREAS, the Principal did on June 3, 2013
 enter into a contract with said Oblige for
Various chain link dugouts for LFUCG Parks and Recreation

which contract is by reference made a part hereof and is hereinafter referred to as the contract.
 NOW, THEREFORE, THE CONDITION OF THIS OBLIGATION, is such that if the Principal shall indemnify the Oblige against any
 loss or damage directly arising by reason of the failure of the Principal to faithfully perform said contract, then this obligation shall be
 null and void; otherwise to remain in full force and effect.

This bond is executed and accepted subject to the following conditions:

- (1) That the Oblige shall faithfully and punctually perform all the terms and conditions of said contract to be performed by the Oblige.
- (2) That the Oblige shall notify the Surety by registered letter, addressed and mailed to it at its home office, 136 North Third Street, Hamilton, Ohio 45025, of any breach of said contract within a reasonable time after such breach shall have come to the knowledge of the Oblige.
- (3) No suit at law or proceedings in equity to recover on this bond shall be instituted after one (1) year from the date of acceptance of the project.

SIGNED, SEALED AND DATED : June 3, 2013

Rio Grande Fence Company, Inc.
 Principal

By: _____

The Ohio Casualty Insurance Company

By: Ronald E. Carroll (Attorney-in-Fact)



The Ohio Casualty Insurance Company

Payment Bond

601059662

KNOW ALL MEN BY THESE PRESENTS,

That we Rio Grande Fence Company, Inc., as Principal,
 (hereinafter called Principal) and The Ohio Casualty Insurance Company, with principal offices in Keene,
 New Hampshire, as Surety, (hereinafter called Surety) are held and firmly bound unto
Lexington-Fayette Urban County Government
 as Oblige, (hereinafter called Oblige), in the amount of
One hundred forty-eight thousand, eight hundred thirty-one Dollars \$ 148,831.00
 for payment of which sum well and truly to be made, we bind ourselves, our heirs, executors, administrators, successors and assigns
 firmly by these presents.

WHEREAS, the Principal did on June 3, 2013
 enter into a contract with said Oblige for
Various chain link dugouts for LFUCG Parks and Recreation

which contract is by reference made a part hereof and is hereinafter referred to as the contract.
 NOW, THEREFORE, THE CONDITION OF THIS OBLIGATION, is such that if the Principal shall indemnify the Oblige against any
 loss or damage directly arising by reason of the failure of the Principal to pay all just claims for labor and material furnished in the
 completion of said contract by persons, firms or corporations having direct contracts with the Principal, then this obligation shall be
 null and void; otherwise to remain in full force and effect.

This bond is executed and accepted subject to the following conditions:

- (1) That the Oblige shall faithfully and punctually perform all the terms and conditions of said contract to be performed by the Oblige.
- (2) That the Oblige shall notify the Surety by registered letter, addressed and mailed to it at its home office, 62 Maple Avenue, Keene, New Hampshire 03431, of any breach of said contract within a reasonable time after such breach shall have come to the knowledge of the Oblige.
- (3) No suit at law or proceedings in equity to recover on this bond shall be instituted after one (1) year from the date of acceptance of the project.

SIGNED, SEALED AND DATED : June 3, 2013

Rio Grande Fence Company, Inc.
 Principal

By: _____

The Ohio Casualty Insurance Company

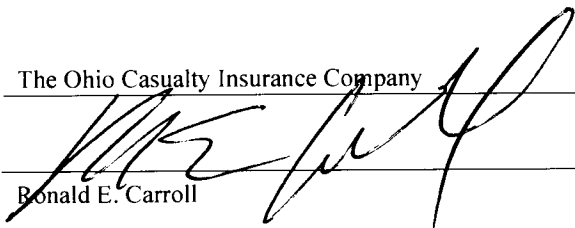
By:  _____
 Ronald E. Carroll (Attorney-in-Fact)

Principal: Rio Grande Fence Company, Inc.

POWER OF ATTORNEY

Agency Name: CARROLL INS AGCY

THE OHIO CASUALTY INSURANCE COMPANY

Obligee: Lexington-Fayette Urban County Government

Bond Number: 601059662

Know All Men by These Presents: That THE OHIO CASUALTY INSURANCE COMPANY, a New Hampshire Corporation, pursuant to the authority granted by Article IV, Section 12 of the Code of Regulations and By-Laws of The Ohio Casualty Insurance Company, do hereby nominate, constitute and appoint: Ronald E. Carroll, Stephen E. Carroll, Kelly Stone of LEXINGTON, Kentucky its true and lawful agent(s) and attorney(ies)-in-fact, to make, execute, seal and deliver for and on its behalf as surety, and as its act and deed any and all BONDS, UNDERTAKINGS, and RECOGNIZANCES, excluding, however, any bond(s) or undertaking(s) guaranteeing the payment of notes and interest thereon.

And the execution of such bonds or undertakings in pursuance of these presents, shall be as binding upon said Company, as fully and amply, to all intents and purposes, as if they had been duly executed and acknowledged by the regularly elected officers of said Company at their administrative offices in Keene, NH, in their own proper persons. The authority granted hereunder supersedes any previous authority heretofore granted the above named attorney(ies)-in-fact.

In WITNESS WHEREOF, the undersigned officer of the said The Ohio Casualty Insurance Company has hereunto subscribed his name and affixed the Corporate Seal of said Company this 1st day of December, 2012.



Gregory W. Davenport

Gregory W. Davenport Assistant Secretary

STATE OF WASHINGTON
COUNTY OF KING

On this 1st day of December, 2012 before the subscriber, a Notary Public of the State of Washington, in and for the County of King, duly commissioned and qualified, came Gregory W. Davenport, Assistant Secretary of The Ohio Casualty Insurance Company, to me personally known to be the individual and officer described in, and who executed the preceding instrument, and he acknowledged the execution of the same, and being by me duly sworn deposes and says that he is the officer of the Company aforesaid, and that the seal affixed to the preceding instrument is the Corporate Seal of said Company, and the said Corporate Seal and his signature as officer were duly affixed and subscribed to the said instrument by the authority and direction of the said Corporation.

IN TESTIMONY WHEREOF, I have hereunto set my hand and affixed my Official Seal at the City of Seattle, State of Washington, the day and year first above written.



KDRiley

Notary Public in and for County of King, State of Washington
My Commission expires December 9, 2013

This power of attorney is granted under and by authority of Article IV, Section 12 of the By-Laws of The Ohio Casualty Insurance Company, extracts from which read:

ARTICLE IV - Officers: Section 12. Power of Attorney.

Any officer or other official of the Corporation authorized for that purpose in writing by the Chairman or the President, and subject to such limitation as the Chairman or President may prescribe, shall appoint such attorneys-in-fact, as may be necessary to act in behalf of the Corporation to make, execute, seal, acknowledge and deliver as surety any and all undertakings, bond, recognizances and other surety obligations. Such attorneys-in-fact, subject to the limitations set forth in their respective powers of attorney, shall have full power to bind the Corporation by their signature and execution of any such instruments and to attach thereto the seal of the Corporation. When so executed, such instruments shall be as binding as if signed by the President and attested to by the Secretary.

Any power or authority granted to any representative or attorney-in-fact under the provisions of this article may be revoked at any time by the Board, the Chairman, the President or by the officer or officers granting such power or authority.

This certificate and the above power of attorney may be signed by facsimile or mechanically reproduced signatures under and by authority of the following vote of the board of directors of The Ohio Casualty Insurance Company effective on the 15th day of February, 2011:

VOTED that the facsimile or mechanically reproduced signature of any assistant secretary of the company, wherever appearing upon a certified copy of any power of attorney issued by the company in connection with surety bonds, shall be valid and binding upon the company with the same force and effect as though manually affixed.

CERTIFICATE

I, the undersigned Assistant Secretary of The Ohio Casualty Insurance Company, do hereby certify that the foregoing power of attorney, the referenced By-Laws of the Company and the above resolution of their Board of Directors are true and correct copies and are in full force and effect on this date.

IN WITNESS WHEREOF, I have hereunto set my hand and the seal of the Company this 3rd day of June 2013



David M. Carey

David M. Carey Assistant Secretary

PART VII

PERFORMANCE BOND

KNOW ALL MEN BY THESE PRESENTS, that

(Name of CONTRACTOR)

(Address of CONTRACTOR)

a _____, hereinafter
(Corporation, Partnership, or Individual)

called Principal, and _____
(Name of Surety)

(Address of Surety)

hereinafter called Surety, are held and firmly bound unto

LEXINGTON-FAYETTE URBAN COUNTY GOVERNMENT
200 East Main Street, Third Floor
Lexington, Kentucky 40507

hereinafter called "OWNER" in the penal sum of: _____
Dollars, (\$ _____), for the payment of whereof Principal and Surety bind themselves, their heirs,
executors, administrators, successors, and assigns, jointly and severally, firmly by these presents.

WHEREAS, Principal by written agreement is entering into a Contract with OWNER for New Chain Link
Dugouts – Various Locations, Bid #13-2013, in accordance with drawings and specifications prepared by:
the LFUCG Division of Parks and Recreation which Contract is by reference made a part hereof, and is
hereinafter referred to as the Contract.

NOW THEREFORE, THE CONDITION OF THIS OBLIGATION is such that if the Principal shall
promptly and faithfully perform said Contract, then this obligation shall be null and void; otherwise it shall
remain in full force and effect.

The Surety hereby waives notice of any alteration or extension of time made by the OWNER.

Whenever, Principal shall be, and declared by OWNER to be in default under the Contract, the OWNER
having performed OWNER'S obligations thereunder, the Surety may promptly remedy the default, or shall
promptly:

- (1) Complete the Contract in accordance with its terms and conditions or
- (2) Obtain a bid or bids for completing the Contract in accordance with its terms and conditions, and upon determination by Surety of the lowest responsible bidder, or if the OWNER elects, upon determination by the OWNER and Surety jointly of the lowest responsible bidder, arrange for a Contract between such bidder and OWNER, and make available as Work progresses (even though there may be a default or a succession of defaults under the Contract or Contracts of completion arranged under this paragraph) sufficient funds to pay the cost of completion less the balance of the Contract Price; but not exceeding, including other costs and damages for which the Surety may be liable hereunder, the amount set forth in the first paragraph hereof. The term "balance of the Contract Price", as used in this paragraph shall mean the total amount payable by OWNER to Principal under the Contract and any amendments thereto, less the amount properly paid by OWNER to Principal.

Any suit under this bond must be instituted before the expiration of two (2) years from the date on which final payment under the Contract falls due.

No right of action shall accrue on this bond to or for the use of any person or corporation other than the OWNER named herein or the heirs, executors, administrators or successors of OWNER.

IN WITNESS WHEREOF, this instrument is executed in _____ each one of which shall be
(number)
deemed an original, this the _____ day of _____, 20_____.

ATTEST:

(Principal) Secretary

Principal

BY: _____(s)

(Address)

Witness as to Principal

(Address)

ATTEST:

(Surety) Secretary

Surety

BY: _____

Attorney-in-Fact

(Address)

(SEAL)

Witness as to Surety

(Address)

TITLE: _____

Surety

BY: _____

TITLE: _____

NOTE: The number of executed counterparts of the bond shall coincide with the number of executed counterparts of the Contract.

PART VII

PAYMENT BOND

KNOW ALL MEN BY THESE PRESENT: that

(Name of Contractor)

(Address of Contractor)

a _____, hereinafter
(Corporation, Partnership or Individual)

called Principal, and _____
(Name of Surety)

(Address of Surety)

hereinafter called Surety, are held and firmly bound unto:

LEXINGTON-FAYETTE URBAN COUNTY GOVERNMENT
200 East Main Street, Third Floor
Lexington, Kentucky 40507

Obligee, hereinafter called OWNER, for the use and benefit of claimants as hereinafter defined, in the amount of _____ Dollars (\$ _____) the payment whereof Principal and Surety bind themselves, their heirs, executors, administrators, successors, and assigns, jointly and severally, firmly by these presents.

WHEREAS, Principal by written agreement is entering into a Contract with OWNER for New Chain Link Dugouts – Various Locations, Bid # 13-2013 in accordance with drawings and specifications prepared by: the LFUCG Division of Parks and Recreation which Contract is by reference made a part hereof, and is hereinafter referred to as the Contract.

NOW, THEREFORE, THE CONDITION OF THIS OBLIGATION is such that, if Principal shall promptly make payment to all claimants as hereinafter defined for all labor and material used or reasonably required for use in the performance of the Contract, then this obligation shall be void; otherwise it shall remain in full force and effect, subject, however, to the following conditions.

1. A claimant is defined as one having a direct contract with the Principal or with a Subcontractor of the Principal for labor, material, or both, used or reasonably required for use in the performance of the Contract, labor and material being construed to include that part of water, gas, power, light, heat, oil, gasoline, telephone service or rental of equipment directly applicable to the Contract.

2. The above named Principal and Surety hereby jointly and severally agree with the OWNER that every claimant as herein defined, who has not been paid in full before the expiration of a period of ninety (90) days after the date on which the last of such claimant's work or labor was done or performed, or materials were furnished by such claimant, may sue on this bond for the use of such claimant, prosecute the suit to final judgment for such sum or sums as may be justly due claimant, and have execution thereon. The OWNER shall not be liable for the payment of any costs or expenses of any such suit.
3. No suit or action shall be commenced hereunder by any claimant:
 - (a) Unless claimant, other than one having a direct contract with the Principal, shall have given written notice to any two of the following: The Principal, the OWNER, or the Surety above named, within ninety (90) days after such claimant did or performed the last of the Work or labor, or furnished the last of the materials for which said claim is made, stating with substantial accuracy the amount claimed and the name of the party to whom the materials were furnished, or for whom the Work or labor was done or performed. Such notice shall be served by mailing the same by registered mail or certified mail, postage prepaid, in an envelope addressed to the Principal, OWNER, or Surety, at any place where an office is regularly maintained for the transaction of business, or served in any manner in which legal process may be served in the state in which the aforesaid project is located, save that such service need not be made by a public officer.
 - (b) After the expiration of one (1) year following the date on which Principal ceased Work on said Contract, it being understood, however, that if any limitation embodied in this bond is prohibited by any law controlling the construction hereof such limitation shall be deemed to be amended so as to be equal to the minimum period of limitation permitted by such law.
 - (c) Other than in a state court of competent jurisdiction in and for the county or other political subdivision of the state in which the project, or any part thereof, is situated, or in the United States District Court for the district in which the project, or any part thereof, is situated, and not elsewhere.
4. The amount of this bond shall be reduced by and to the extent of any payment or payments made in good faith hereunder, inclusive of the payment by Surety of mechanics' liens which may be filed of record against aid improvement, whether or not claim for the amount of such lien be presented under and against this bond.

IN WITNESS WHEREOF, this instrument is executed in _____ counterparts, each one of
(number)

which shall be deemed an original, this the _____ day of _____, 20_____.

ATTEST:

(Principal)

(Principal) Secretary

(SEAL)

BY: _____(s)

(Address)

(Witness to Principal)

(Address)

(Surety)

ATTEST:

BY: _____
(Attorney-in-Fact)

(Surety) Secretary

(SEAL)

Witness as to Surety

(Address)

(Address)

NOTE: The number of executed counterparts of the bond shall coincide with the number of executed counterparts of the Contract.

END OF SECTION

PART VIII

ADDENDA

All addenda issued during the bidding of the Project will be reproduced in the signed Contract Documents, on the pages following this heading sheet.

<u>Addendum Number</u>	<u>Title</u>	<u>Date</u>
1.	_____	_____
2.	_____	_____
3.	_____	_____
4.	_____	_____
5.	_____	_____

PART IX

TECHNICAL SPECIFICATIONS

02610 – Concrete

02711 – Chain Link Dugouts, Roof, Fences, Gates

02820 – Chain Link Fence, Galvanized

02870 – Site Specialties (Team Bench)

02920 – Seeding

DIVISION 2
SECTION 02610 - CONCRETE

PART 1-GENERAL

A. Quality Assurance/Product

1. **Concrete** shall be mixed and delivered according to the requirements of ASTM C94, "Specifications for Ready-Mixed Concrete." Each cubic yard of concrete shall have the following:
 - a.) A minimum of 4000 p.s.i. compressive strength at 28 days.
 - b.) Local aggregate #57 topsize.
 - c.) An air content of 6+/- 2%.
 - d.) Slump shall be 5" maximum for hand placement, 3" maximum with machine.
 - e.) Contractor shall provide delivery tickets from concrete plant to verify mix specifications upon request.
2. **Wire fabric** shall be cold drawn steel wires arranged at right angles to each other and electrically welded together at all intersections. Wire fabric shall be installed in the center of all interior concrete slab on grade, and as called for on the plan.
3. **Water** shall be clean and free from injurious substances.
4. **Vapor barrier** shall be 6 mil polyethylene film in widths as wide as practicable.

PART 2 - PERFORMANCE

A. Subgrade Preparation

1. The subgrade under all pavement shall be brought to the required lines and grades and compacted to a firm and unyielding condition with a uniform density. Any pockets of soft material that cannot be compacted shall be removed and replaced with suitable material. Ready-mix trucks and other equipment shall be permitted to operate on the prepared subgrade providing the subgrade is kept smooth and compacted prior to placing concrete. The subgrade shall be in a moist condition, but not muddy, at the time of placement of the concrete.

B. Base

1. DUGOUT PAD - Install 3 inches of #57 gravel, compacted
2. SIDEWALK/PAVEMENT – Install 6 inches of DGA, compacted

C. Joints

1. The pavement shall be jointed to control cracking.
2. Longitudinal and transverse joint spacings shall be at regular intervals as shown on plan.
3. The required contraction joint spacing shall be 5' o.c., typical, or as noted on the plan. Expansion joints as per plan, 25' o.c. on sidewalk.
4. Contraction joints shall be made by sawing, tooling, or installing an approved insert to a depth of 1/4 of the slab thickness, as shown on plan. Sawed joints shall be cut as soon as possible without ravelling the concrete. In warm weather, joints shall be cut on the day of pour.
5. Joints shall be continuous across the slab and must extend completely.
6. Full depth expansion (isolation) joints, 1/4" to 1/2" thick, shall be installed to isolate fixed objects and where fixed objects abut, and as noted on plans.

D. Concrete Placing, Finishing and Texturing

1. DUGOUT PAD concrete shall be properly placed on the prepared subgrade and base at 4.5" deep, adequately consolidated and struck off to the proper elevation.
2. SIDEWALK/PAVEMENT concrete shall be properly placed on the prepared subgrade and base at 4" deep, adequately consolidated and struck off to the proper elevation.

3. All concrete shall be placed continuously to prevent the formation of "cold joints." Wherever placing operations stop, a bulkhead will be installed to form a straight joint.
4. The sequence of finishing operations shall be the strike off and consolidation, floating (if necessary), straight edging and texturing.
5. Adding water to the surface of the concrete to assist in finishing operations shall not be permitted, it shall be applied as a fog spray.
4. The pavement surface shall drain at a slope of 1/4" per foot unless otherwise specified on the plans.
5. Final surface texture shall be broom finish.

E. Curing

1. **Summer - (April 15 - October 15)**
Concrete shall be cured by protecting it against loss of moisture, rapid temperature change, and mechanical injury for at least 5 to 7 days after placement. A liquid membrane-forming compound shall be uniformly sprayed on all exposed surfaces.
2. **Winter - (October 15 - April 15)**
Concrete shall be covered with a plastic sheet 5 to 7 days. In areas that will receive de-icer applications, concrete shall be sealed with a sealant penetrant material such as linseed oil and thinner at a ratio of 50:50 on each material, 200 sq. ft. per gallon, prior to opening to traffic.

F. Clearing and Protection

1. **Opening to Traffic**
Pavement under construction shall be protected with barricades, and all traffic (with the exception of joint sawing equipment) shall be excluded from the new pavement for seven (7) days.
2. **Pavement Protection**
The contractor shall be responsible for concrete placed during rain or cold weather. When concrete is placed late in the year, the contractor shall submit a plan of procedures for protection of the concrete to the Landscape Architect for approval prior to construction.
3. **Damage**
The completed concrete shall be protected from damage until accepted. The Contractor shall repair damaged concrete and clean concrete discolored during construction. Concrete that is damaged shall be removed and reconstructed for the entire length between joints, not by refinishing the damaged portion.

G. Cleanup

1. Site shall be left clean and free of debris.

DIVISION 2
SECTION 02711 - CHAIN LINK DUGOUTS, DUGOUT ROOFS, FENCES, GATES

- Part 1—General
- Part 2—Products
- Part 3—Execution
- Part 4—Cleanup

PART 1 - GENERAL

1.01 WORK INCLUDED

- A. The work covered by these specifications includes the furnishing of all labor, equipment, appliances, transportation and materials required for the installation and/or erection of dugout enclosures, dugout roofs, fences, gates, and related items as drawn or herein specified.

1.02 RELATED WORK SPECIFIED ELSEWHERE

1.03 REFERENCES/STANDARDS

- A. Where American Society for Testing and Materials (ASTM) standards are referenced, they are made a part of this Section unless otherwise noted. Such standards shall be the current issues and standards.

1.04 SUBMITTALS

- A. Shop Drawings: Include complete details of dugout, dugout roof (including frame), fence and gate construction, fence height, chain link fabric gauges, post spacing, dimensions and unit weights of framework, and concrete footing details. Actual samples and certificates of compliance may be requested.

1.05 QUALITY ASSURANCE

- A. Qualifications: Contractors or subcontractors performing work under this Section shall be qualified to do such work and hold the appropriate registration, license, or other permit as required by state or local law.
- B. Requirements of Regulatory Agencies:
 - 1. Contractor shall procure all permits and licenses, pay all charges and fees, and give all notices necessary and incidental to the due and lawful prosecution of the work.
 - 2. Contractor shall comply with all code requirements.

1.06 JOB CONDITIONS

- A. Site Inspection: Contractor shall familiarize him/herself with the site, the plans, the specifications, special provisions, and plan requirements, and is responsible for calling any discrepancies or special problems to the attention of the Division of Parks & Recreation Representative.

B. Protection:

1. Protect, maintain, and restore bench marks, monuments, and other reference points affected by this work. If such items are displaced or destroyed by this work, they will be reestablished by a licensed surveyor at no expense to the Owner. After items have been permanently set, certify the work and furnish certification to the Owner's Representative

C. Coordination

1. Contractor shall coordinate with Owner or Owner's representative prior to commencement of work.
2. Contractor shall coordinate with other trades affected by the work.

D. Sequencing/Scheduling: Contractor shall keep him/herself informed of the construction progress of all other Contractors and/or subcontractors working on the project, particularly where they affect his/her work, and shall coordinate his/her work with that of other Contractors to ensure efficient and orderly progress of the work.

E. Construction Stakes

1. Construction stakes shall be set to mark the general location, alignment, elevation, and grade of the work. The Contractor shall assume full responsibility for dimension and elevations from such stakes.
2. The Contractor shall furnish at his/her expense the size, quality, and quantity of stakes required.

1.07 WARRANTIES/GUARANTEES

A. For a period of one year from the date of issuance of the Final Certificate of Payment for the work, the Contractor shall furnish and install, without cost to the Owner, any and all work which, in the judgment of the Owner, proves defective in materials and/or workmanship.

B. Product Delivery, Storage and Handling

1. Deliver materials with manufacturer's tags and labels intact.
2. Handle and store to avoid damage.

PART 2 - PRODUCTS

2.01 MATERIALS

A. Dugout Framework: Type I Steel Pipe.

1. Upright framework shall be 3" o.d. schedule 40 galvanized steel tube
2. Horizontal top, mid and bottom rail shall be 1 5/8" o.d. schedule 40 galvanized steel tube attached by either welding or galvanized couplers
3. All steel tube shall have 1.8 ounces of zinc coating per square foot of surface area conforming to Standard Specification ASTM F1083

4. Pipe shall be straight, true to section, and conform to the following weights:
 - a. Base Metal - shall be steel of such quality that the fabricated product will meet the performance criteria set forth in this standard. The steel strip used in the manufacture of the pipe shall conform to ASTM A-569
 - b. Zinc - used in the manufacture of flo-coat pipe and shall conform to ASTM B-6 High Grade and Special High Grade Zinc.
 - c. Clear Coating – shall be manufactured from high grade raw materials which produce a crosslinked acrylic polyurethane coating.
 - d. Internal Coating - shall have a minimum zinc power loading of 87% by weight and be capable of providing galvanic protection.

B. Roof Framework

1. Roof frame shall be 4" x 3.5" angle steel perimeter; paint to match roof
2. Roof supports shall be 3" x 1.5" steel "C" channel at 2 ft o.c.; paint to match roof
3. Roof frame and supports to receive:
 - a. 1 coat Sherwin Williams DTM Acrylic Primer/Finish or approved equal
 - b. 2 coats Sherwin Williams "Duration" Exterior Acrylic Latex or approved equal
 - c. Owner to select from standard colors

C. Roof

1. Pre-finished 26 gauge, 5V ribbed steel metal roof system with end caps and flashing on 30# felt over 5/8" treated plywood
2. Roof color to be Keenland Green or approved equal
3. All roof supports and ceiling to be painted (min 2 coats) to match roof

D. Chain Link Fabric

1. Shall conform to Federal specifications RR-F 191A.
2. Type A, 2" square mesh fabric
3. Top edges knuckled
4. #9 gauge wire, conforming to ASTM 342-1, Class 1.

E. Technical

1. Weight of Zinc Coatings - shall be determined by the method contained in ASTM A-90.
2. Chromate Coating Weight - shall be 30 micrograms/sq. in.

3. Exterior Clear Coated Surface - shall have a demonstrated ability to resist 1000 hours of exposure to salt fog with a maximum of 5% red rust when conducted in accordance with ASTM-B117.

F. Performance Properties of the Product

1. The strength of line, end, corner and pull posts shall be determined by a 6-foot cantilever beam test.
2. The strength of top rail shall be determined by using a 10' tree supported beam test.

	Diameter	SS40st/ft	6' Cantilever
Line posts, gate post	2-1/2"	3.117 lbs	330 lbs
End, corner, gate post	3"	4.640 lbs	610 lbs
*Top rails	1-5/8"	1.836 lbs	135 lbs
*Braces	1-5/8"	1.836 lbs	135 lbs
*Gate frames	1-5/8"	1.836 lbs	135 lbs

*Note: 10' support load 327 lbs. All pipe materials shall be prime, no welds or "reject" pipe. Letter of "Mill Certification" shall be provided on pipe.

- G.** Provide approved malleable post tops, sleeves, and other fittings for complete installation. All such frame work shall be hot-dip, zinc-coated after fabrication.

PART 3—EXECUTION

A. Inspections

1. Verify that final grading in fence location is completed without irregularities which would interfere with fence installation.
2. Do not commence work until unsatisfactory conditions have been corrected.

B. Installation

1. Posts shall be buried in concrete cylinders to a minimum depth of 27" to 30" of concrete.
2. Concrete cylinders shall have the following minimum diameter:

Line posts	9"
Corner posts	12"
Gate posts	12"

3. Where installed through asphalt paving, the top of the cylinders shall be flush with the

surface of the surrounding asphalt. Top of the cylinder shall be troweled to a smooth surface.

4. Unless otherwise indicated, posts shall be spaced not more than 10 feet apart.
5. Fabric to be tied every foot with either 6 gauge aluminum or 11 gauge steel ties.

PART 4—CLEANUP

- A.** All rough edges, tags and staples to be removed.
- B.** Site is to be left free of all trash and debris.

Note: All equals to be submitted to the Park Designer 48 hours prior to the bid opening for pre-approval.

END OF SECTION

DIVISION 2
SECTION 02870—SITE SPECIALTIES

PART 1—GENERAL

- A. Install all miscellaneous specialties and necessary items to complete the work required by the plans and herein specified.

PART 2—PRODUCT

- A. Team Benches (2): Outdoor Aluminum model PCTS 15 inground mount OR EQUAL

PART 3—EXECUTION

- A. Installation – Assemble and install per plans and manufacturers specifications.
- B. Cleanup - Site is to be left free of all trash and debris.

PART 4—CLEAN UP

- A. All rough edges, tags and staples are to be removed.
- B. Site is to be left free of all trash and debris.

NOTE: All equals must be submitted minimum of 48 hours prior to the bid opening for approval.

END OF SECTION

DIVISION 2
SECTION 02920 - SEEDING

- Part 1—General
- Part 2—Products
- Part 3—Execution

PART 1—GENERAL

A. Quality Assurance

1. Seed mixes and germination rates to be certified and guaranteed by distributor.
2. Fertilizer to be delivered to the site in original unopened containers bearing the manufacturer's guaranteed statement of analysis.

B. Product Delivery, Storage, and Handling

1. All seed, fertilizer, lime and mulch to be stored under shelter.

C. Job Conditions

1. Begin fertilizing after grading is finished.
2. Do not fertilize or seed frozen or saturated soil.
3. Erect traffic barriers.
4. Soil is to be analyzed by local extension agent for fertilizer verification.

PART 2—PRODUCTS

A. Materials

1. **Fertilizer:** The fertilizer to be used on all seeding areas shall be non-burning urea form fertilizer with 5% of the nitrogen as methylene urea. The fertilizer shall meet the following minimum requirement; 15% nitrogen, 5% phosphorus, 5% potash. The fertilizer shall be delivered to the site in the original unopened containers which shall bear the manufacturer's guaranteed statement of analysis. Application rate is 26 lbs/acre worked into the top 3" of the soil.
2. **Lime:** Ground agricultural limestone shall be of the finest quality available.
3. **Seed:** Jaguar fescue or equal.
4. **Mulch:** Use straw to protect all seeded areas except for sloped areas. Straw is to be clean wheat or clean oat straw. *Use an erosion control blanket North American Green BioNet product, S150BN double net straw blanket, or approved equal on the embankment areas.*
5. **Water:** Water is to be free of substances harmful to plant growth.

B. Seeding:

1. Application rate is 300 lbs/acre on site.

PART 3 –EXECUTION

A. Inspection

1. Verify that related work has been completed.
2. Do not start work until conditions are satisfactory.

NOTE: All equals must be submitted to the Park designer 48 hours prior to the bid opening.

END OF SECTION

PLEASE READ THROUGH INSTRUCTIONS ONCE BEFORE ASSEMBLING

- (1) SLIP ON CHANNEL END CAPS (ONE ON EACH END OF PLANKS). IF NECESSARY, TAP LIGHTLY WITH A WOOD BLOCK OR RUBBER Mallet. TAP ONLY ON THE CORNERS OF THE CHANNEL END CAPS. LONG LEG OF THE CHANNEL END CAPS SHOULD BE PLACED ON THE UNDERSIDE OF PLANKS. DRILL 3/16" Ø HOLES THROUGH CHANNEL END CAP AND PLANKS, AS SHOWN ON DRAWING. INSERT DRIVE RIVETS INTO THE HOLES AND HIT FIRMLY WITH A HAMMER.
- (2) LAY PCTS FRAMES ON FIRM LEVEL GROUND, APPROXIMATELY SIX FEET APART. STAND FRAMES UPRIGHT ON THEIR BACKS, SO THAT SEAT TUBES ARE APPROXIMATELY IN THE VERTICAL POSITION. PLACE 2 x 10 BACKREST PLANK AGAINST FRAMES SO THAT THE PLANK DOES NOT OVERHANG THE END MOST FRAMES MORE THAN 1'-6" (3" MIN. TO 1'-6" MAX.) SEE DRAWING FOR FURTHER CLARIFICATION.
- (3) ATTACH PCTS FRAMES TO BOTTOM SIDE OF BACKREST PLANK USING 2 BOLT CLIPS, 5/16" x 3" CARRIAGE BOLTS, LOCK WASHERS AND HEX NUTS, MAKING SURE THAT FRAMES ARE PERPENDICULAR TO BACKREST PLANK. SEE BOLT CLIP DETAIL.
- (4) PLACE 2 x 12 SEAT PLANK AGAINST PCTS FRAMES SO THAT THE PLANKS DO NOT OVERHANG THE END MOST FRAMES MORE THAN 1'-6" (3" MIN. TO 1'-6" MAX.) SEE DRAWING FOR FURTHER CLARIFICATION.
- (5) ATTACH PCTS FRAMES TO BOTTOM SIDE OF SEAT PLANKS USING 2 BOLT CLIPS, 5/16" x 3" CARRIAGE BOLTS, LOCK WASHERS, LOCK NUTS, LOCK WASHERS AND HEX NUTS, MAKING SURE THAT FRAMES ARE PERPENDICULAR TO SEAT PLANKS. SEE BOLT CLIP DETAIL.
- (6) TIGHTEN ALL BOLTS.
- (7) MEASURE THE EXACT DISTANCE BETWEEN FRAMES OF THE ASSEMBLED BENCH. MEASURE AND MARK THESE DISTANCES ON THE GROUND.
- (8) DIG HOLES AT THE DESIGNATED LOCATIONS AND POUR READY-MIX CONCRETE INTO THE HOLES.
- (9) TURN THE BENCH UPRIGHT AND PLACE THE LEGS IN THE PREPARED CONCRETE. POSITION THE HEIGHT OF THE BENCH SO THAT THE SEAT PLANK SURFACE IS 17" TO 18" ABOVE GROUND LEVEL. SHORE ASSEMBLED UNIT AS REQUIRED UNTIL CONCRETE HAS ADEQUATELY CURED, TO ALLOW BENCH TO STAND ON ITS OWN.

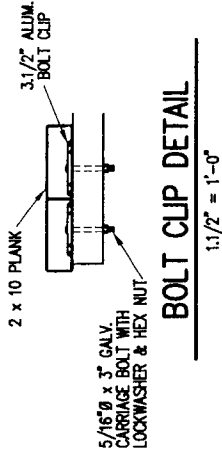
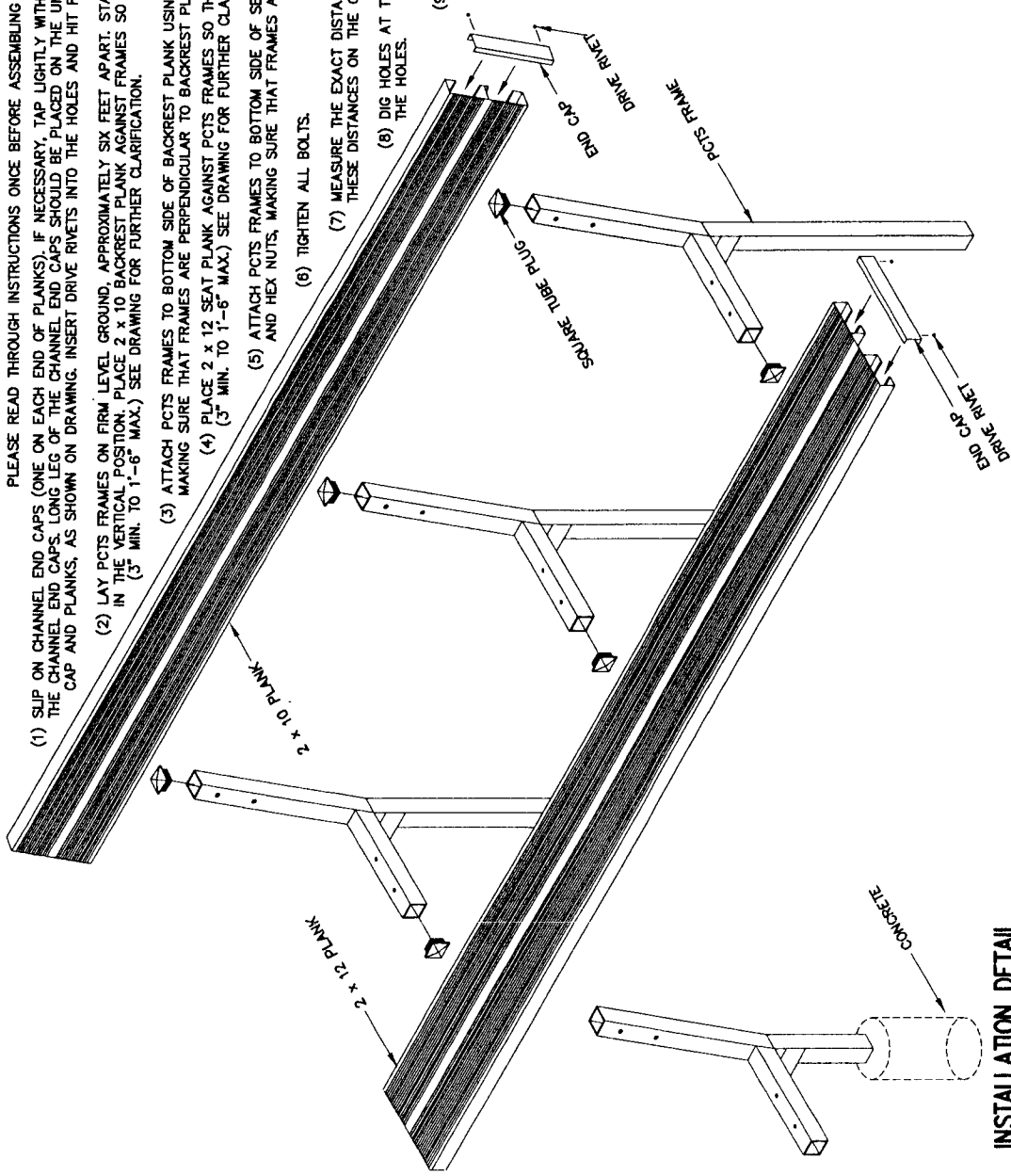

		P.O. BOX 118 GENEVA, ALABAMA 35340 334-664-2266	
		BY	DATE
SCALE	N.T.S.	REVISIONS	
DATE	11/26/00	SEAT FROM OAX-025 TO OAX-055	GDK 02/23/01
DRN	CHM	BACKREST FROM OAX-035 TO OAX-045	GDK 02/23/01
APP'D		REDRAWN	WJW 02/13/06
TITLE			NO.
PCTS BENCH			300-E18

Sheet 8 Site Plan

Wolfrun Baseball Field

1816 Maywick View Lane

Lexington, Kentucky

Notes:

- 1) The contractor will be responsible for repairing any damage done to the existing walks, ballfield and park infrastructure during construction.
- 2) Call Ky811 for a utilities locate prior to starting project.
- 3) Field verify all dimensions.
- 4) Stake corners of new concrete pad for owner's approval before commencing work.

Scale: 1"=20'-0"

Existing Outfield Fence

EXISTING GATE

Dugout opening

New dugout on new 30' x 10' concrete pad

Begin new dugout at the second post in on the 20' fence

Begin new dugout at the second back on the 10' fence

Dugout opening

EXISTING GATE

L.F.U.C.G. Division of Parks

469 Parkway Dr. Lexington, Kentucky
859-288-2900

March 27, 2013
Revised May 10, 2013

PLAN # 2

Sheet 2 Site Plan

Castlewood Park Baseball Field

201 Castlewood Dr.
Lexington, Kentucky
Scale: 1"=20'-0"

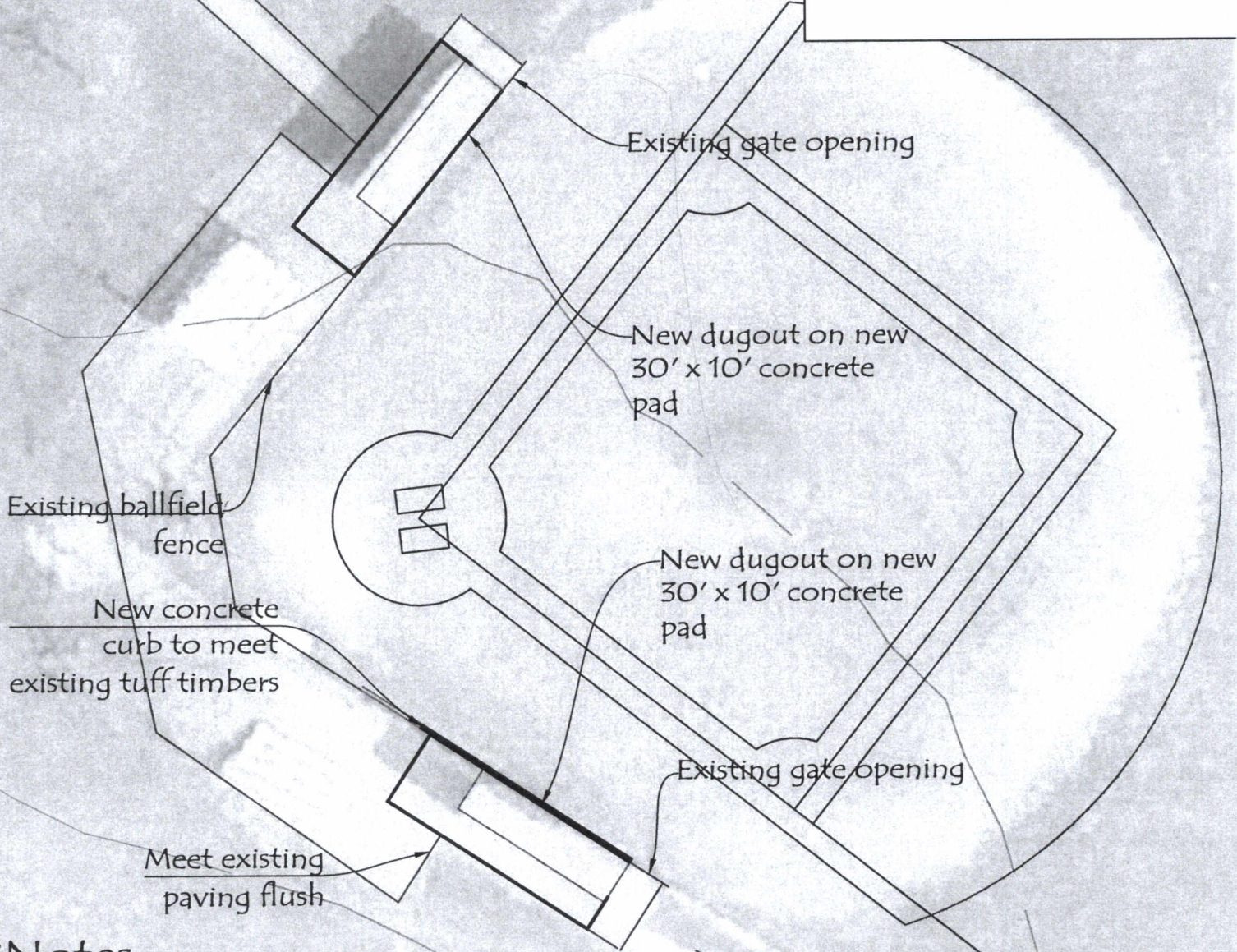
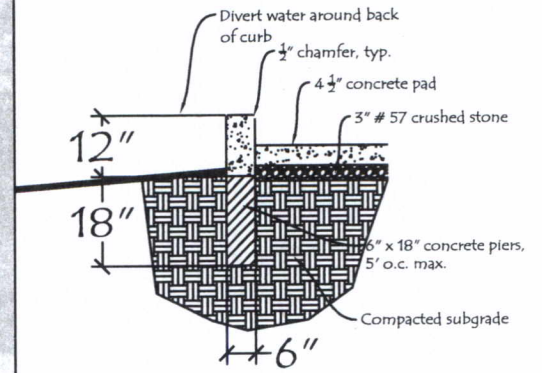

Notes:

- 1) The contractor will be responsible for repairing any damage done to the existing walks, ballfield and park infrastructure during construction.
- 2) Call Ky811 for a utilities locate prior to starting project.
- 3) Field verify all dimensions.
- 4) Stake corners of new concrete pad for owner's approval before commencing work.

L.F.U.C.G. Division of Parks
 469 Parkway Dr. Lexington, Kentucky
 859-288-2900

February 4, 2012
 Revised May 10, 2013

K:\PROJECTS\Castlewood\13\dugouts\dugouts.dwg, 5/15/2013 10:08:19 AM, Planning - Color C935 P53

Sheet 3 Site Plan

Castlewood Park Softball Field

201 Castlewood Dr.
Lexington, Kentucky

Scale: 1"=20'-0"

Dugout entrance

Dugout entrance

New dugout on
20'x10' new
concrete pad

Existing ballfield
fence

Notes:

- 1) The contractor will be responsible for repairing any damage done to the existing walks, ballfield and park infrastructure during construction.
- 2) Call Ky811 for a utilities locate prior to starting project.
- 3) Field verify all dimensions.
- 4) Stake corners of new concrete pad for owner's approval before commencing work.

L.F.U.C.G. Division of Parks

469 Parkway Dr. Lexington, Kentucky
859-288-2900

February 4, 2013
Revised May 10, 2013

Sheet 4 Site Plan

Woodland Park

601 East High St.

Lexington, Kentucky

Scale: 1"=20'-0"

Notes:

- 1) The contractor will be responsible for repairing any damage done to the existing walks, ballfield and park infrastructure during construction.
- 2) Call Ky811 for a utilities locate prior to starting project.
- 3) Field verify all dimensions.
- 4) Stake corners of new concrete pad for owner's approval before commencing work.

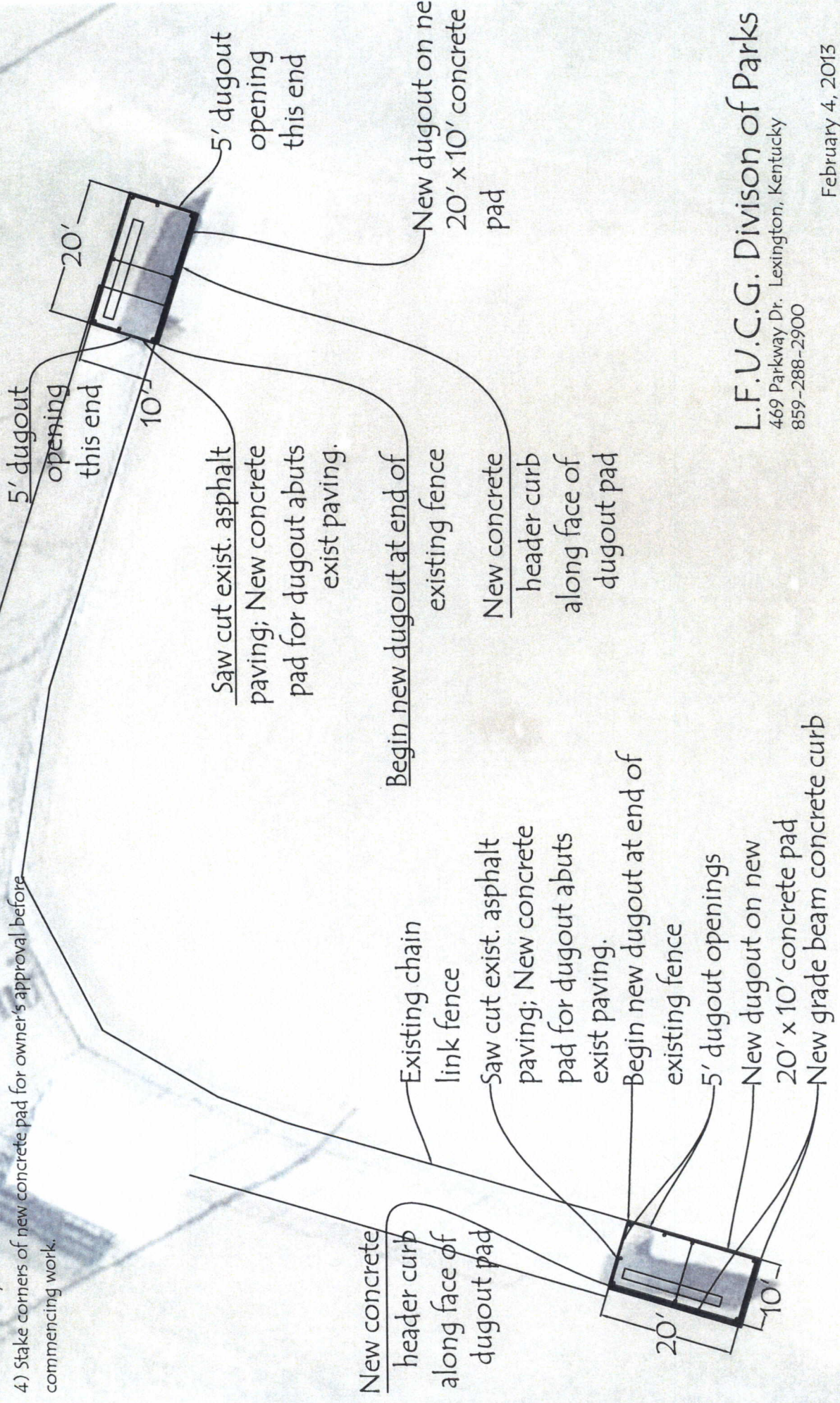

K:\PROJECTS\WOODLAND\F13\Dugout\replacement.dwg, 5/15/2013 10:23:24 AM, Planning - Color G335 P3

L.F.U.C.G. Division of Parks
469 Parkway Dr. Lexington, Kentucky
859-288-2900

February 4, 2013
Revised May 10, 2013

Sheet 5 Site Plan

Kirklevington Park
396 Redding Rd.
Lexington, Kentucky

Scale: 1"=20'-0"

Dugout entrance

New dugout on new
30' x 10' concrete
pad

Existing gate

New dugout on new
30' x 10' concrete
pad

Dugout entrance

Notes:

- 1) The contractor will be responsible for repairing any damage done to the existing walks, ballfield and park infrastructure during construction.
- 2) Call Ky811 for a utilities locate prior to starting project.
- 3) Field verify all dimensions.
- 4) Stake corners of new concrete pad for owner's approval before commencing work.

L.F.U.C.G. Division of Parks

469 Parkway Dr. Lexington, Kentucky
859-288-2900

February 4, 2012
Revised May 10, 2013

K:\PROJECTS\KIRKLEEVINGTON\BASE.dwg, 5/15/2013 10:11:35 AM, Planning - Color C935 P53