



Lexington-Fayette Urban County Government

Lexington, Kentucky
Horse Capital of the World

Division of Central Purchasing

Date of Issue: June 9, 2016

INVITATION TO BID #87-2016 Replacement Windows for Artsplace

Bid Opening Date: June 23, 2015

Bid Opening Time: 2:00 PM

Address: 200 East Main Street, 3rd Floor, Room 338, Lexington, Kentucky 40507

Type of Bid: Firm Bid

Pre Bid Meeting: June 15, 2015

Pre Bid Time: 11:00 AM

Address: 151 Mill Street, Lexington, KY 40507

Sealed bids will be received in the office of the Division of Central Purchasing, 200 East Main Street, Lexington, Kentucky, until **2:00 PM**, prevailing local time on **06/23/2016**. Bids must be received by the above-mentioned date and time. Mailed bids should be sent to:

**Division of Central Purchasing
200 East Main Street, Room 338
Lexington, KY 40507, (859) 258-3320**

The Lexington-Fayette Urban County Government assumes no responsibility for bids that are not addressed and delivered as indicated above. **Bids that are not delivered to the Division of Central Purchasing by the stated time and date will be rejected.** All bids must be signed and have the company name and address, bid invitation number, and the name of the bid on the outside of the envelope.

Bids are to include all shipping costs to the point of delivery located at: 151 Mill St., Lexington, KY 40507

Bid Security Required: ___ Yes No *Cashier Check, Certified Check, Bid Bond (Personal checks and company checks will not be acceptable).*

Performance Bond Required: ___ Yes No

Bid Specifications Met <input checked="" type="checkbox"/> Check One: Exceptions to Bid Specifications. <i>Exceptions shall be itemized and attached to bid proposal submitted.</i>	Proposed Delivery: ~ 35 days after acceptance of bid.
Procurement Card Usage —The Lexington-Fayette Urban County Government may be using Procurement Cards to purchase goods and services and also to make payments. Will you accept Procurement Cards? ___ Yes <input checked="" type="checkbox"/> No	

Submitted by: HERITAGE INSTALLATIONS I, LLC DBA RENEVAL BY ANDERSON

Firm Name

11400 BLUEGRASS PARKWAY

Address

LOUISVILLE, KY 40299

City, State & Zip

Bid must be signed:
(original signature)

John Naisor **COMMERCIAL SALES MGR.**
Signature of Authorized Company Representative – Title

JOHN NAISOR
Representative's Name (Typed or printed)

(502) 266-7762
Area Code - Phone - Extension

(502) 266-5544
Fax #

JOHN@RBALOW.COM
E-Mail Address

The Affidavit in this bid must be completed before your firm can be considered for award of this contract.

AFFIDAVIT

Comes the Affiant, JOHN NAISER, and after being first duly sworn under penalty of perjury as follows:

1. His/her name is JOHN NAISER and he/she is the individual submitting the bid or is the authorized representative of HERITAGE INSTALLATIONS I, LLC DBA RENEWAL BY ANDERSEN the entity submitting the bid (hereinafter referred to as "Bidder")
2. Bidder will pay all taxes and fees, which are owed to the Lexington-Fayette Urban County Government at the time the bid is submitted, prior to award of the contract and will maintain a "current" status in regard to those taxes and fees during the life of the contract.
3. Bidder will obtain a Lexington-Fayette Urban County Government business license, if applicable, prior to award of the contract.
4. Bidder has authorized the Division of Central Purchasing to verify the above-mentioned information with the Division of Revenue and to disclose to the Urban County Council that taxes and/or fees are delinquent or that a business license has not been obtained.
5. Bidder has not knowingly violated any provision of the campaign finance laws of the Commonwealth of Kentucky within the past five (5) years and the award of a contract to the Bidder will not violate any provision of the campaign finance laws of the Commonwealth.
6. Bidder has not knowingly violated any provision of Chapter 25 of the Lexington-Fayette Urban County Government Code of Ordinances, known as "Ethics Act."
7. Bidder acknowledges that "knowingly" for purposes of this Affidavit means, with respect to conduct or to circumstances described by a statute or ordinance defining an offense, that a person is aware or should have been aware that his conduct is of that nature or that the circumstance exists.

Further, Affiant sayeth naught. J. Naiser

STATE OF KENTUCKY

COUNTY OF JEFFERSON

The foregoing instrument was subscribed, sworn to and acknowledged before me by Melissa Fields on this the 23 day of June, 2015.

MELISSA FIELDS
NOTARY PUBLIC
Kentucky, State At Large
My Commission Expires 12/17/2019

My Commission expires: December 17, 2019

Melissa Fields
NOTARY PUBLIC, STATE AT LARGE

Please refer to Section II. Bid Conditions, Item "U" prior to completing this form.

I. GREEN PROCUREMENT

A. ENERGY

The Lexington-Fayette Urban County Government is committed to protecting our environment and being fiscally responsible to our citizens.

The Lexington-Fayette Urban County Government mandates the use of Energy Star compliant products if they are available in the marketplace (go to www.Energystar.gov). If these products are available, but not submitted in your pricing, your bid will be rejected as non-compliant.

ENERGY STAR is a government program that offers businesses and consumers energy-efficient solutions, making it easy to save money while protecting the environment for future generations.

Key Benefits

These products use 25 to 50% less energy
Reduced energy costs without compromising quality or performance
Reduced air pollution because fewer fossil fuels are burned
Significant return on investment
Extended product life and decreased maintenance

B. GREEN SEAL CERTIFIED PRODUCTS

The Lexington-Fayette Urban County Government is also committed to using other environmentally friendly products that do not negatively impact our environment. Green Seal is a non-profit organization devoted to environmental standard setting, product certification, and public education.

Go to www.GreenSeal.org to find available certified products. These products will have a reduced impact on the environment and on human health. The products to be used must be pre-approved by the LFUCG prior to commencement of any work in any LFUCG facility. If a Green Seal product is not available, the LFUCG must provide a signed waiver to use an alternate product. Please provide information on the Green Seal products being used with your bid response.

C. GREEN COMMUNITY

The Lexington-Fayette Urban County Government (LFUCG) serves as a principal, along with the University of Kentucky and Fayette County Public Schools, in the Bluegrass Partnership for a Green Community. The Purchasing Team component of the Partnership collaborates on economy of scale purchasing that promotes and enhances environmental initiatives. Specifically, when applicable, each principal is interested in obtaining best value products and/or services which promote environment initiatives via solicitations and awards from the other principals.

If your company is the successful bidder on this Invitation For Bid, do you agree to extend the same product/service pricing to the other principals of the Bluegrass Partnership for a Green Community (i.e. University of Kentucky and Fayette County Schools) if requested?

Yes X No _____

THROUGH 12/31/16

II. Bid Conditions

- A. No bid may be withdrawn for a period of sixty (60) days after the date and time set for opening.
- B. No bid may be altered after the date and time set for opening. In the case of obvious errors, the Division of Central Purchasing may permit the withdrawal of a bid. The decision as to whether a bid may be withdrawn shall be that of the Division of Central Purchasing.
- C. Acceptance of this proposal shall be enactment of an Ordinance by the Urban County Council.
- D. The bidder agrees that the Urban County Government reserves the right to reject any and all bids for either fiscal or technical reasons, and to award each part of the bid separately or all parts to one vendor.
- E. Minor exceptions may not eliminate the bidder. The decision as to whether any exception is minor shall be entirely that of the head of the requisitioning Department or Division and the Director of the Division of Central Purchasing. The Urban County Government may waive technicalities and informalities where such waiver would best serve the interests of the Urban County Government.
- F. Manufacturer's catalogue numbers, trade names, etc., where shown herein are for descriptive purposes and are to guide the bidder in interpreting the standard of quality, design, and performance desired, and shall not be construed to exclude proposals based on furnishing other types of materials and/or services. However, any substitution or departure proposed by the bidder must be clearly noted and described; otherwise, it will be assumed that the bidder intends to supply items specifically mentioned in this Invitation for Bids.
- G. The Urban County Government may require demonstrations of the materials proposed herein prior to acceptance of this proposal.
- H. Bids must be submitted on this form and must be signed by the bidder or his authorized representative. Unsigned bids will not be considered.
- I. Bids must be submitted prior to the date and time indicated for opening. Bids submitted after this time will not be considered.
- J. All bids mailed must be marked on the face of the envelope:

"Bid on #87-2016 Replacement Windows for Artsplace"

and addressed to: Division of Central Purchasing
 200 East Main Street, Room 338
 Lexington, Kentucky 40507

The Lexington-Fayette Urban County Government assumes no responsibility for bids that are not addressed and delivered as indicated above. Bids that are not delivered to the Division of Central Purchasing by the stated time and date will be rejected.

- K. Bidder is requested to show both unit prices and lot prices. In the event of error, the unit price shall prevail.
- L. A certified check or Bid Bond in the amount of N/A percent of the bid price must be attached hereto. This check must be made payable to the Lexington-Fayette Urban County Government, and will be returned when the material and/or services specified herein have been delivered in accordance with specifications. In the event of failure to perform within the time period set forth in this bid, it is agreed the certified check may be cashed and the funds retained by the Lexington-Fayette Urban County Government as liquidated damages. Checks of unsuccessful bidders will be returned when the bid has been awarded.
- M. The delivery dates specified by bidder may be a factor in the determination of the successful bidder.
- N. Tabulations of bids received may be mailed to bidders. Bidders requesting tabulations must enclose a stamped, self-addressed envelope with the bid.
- O. The Lexington-Fayette Urban County Government is exempt from Kentucky Sales Tax and Federal Excise Tax on materials purchased from this bid invitation. Materials purchased by the bidder for construction projects are not tax exempt and are the sole responsibility of the bidder.

- P. All material furnished hereunder must be in full compliance with OSHA regulations.
- Q. If more than one bid is offered by one party, or by any person or persons representing a party, all such bids shall be rejected.
- R. Signature on the face of this bid by the Bidder or his authorized representative shall be construed as acceptance of and compliance with all terms and conditions contained herein.
- S. The Entity (regardless of whether construction contractor, non-construction contractor or supplier) agrees to provide equal opportunity in employment for all qualified persons, to prohibit discrimination in employment because of race, color, creed, national origin, sex or age, and to promote equal employment through a positive, continuing program from itself and each of its sub-contracting agents. This program of equal employment opportunity shall apply to every aspect of its employment policies and practices.
- T. The Kentucky Equal Employment Opportunity Act of 1978 (KRS 45.560-45.640) requires that any county, city, town, school district, water district, hospital district, or other political subdivision of the state shall include in directly or indirectly publicly funded contracts for supplies, materials, services, or equipment hereinafter entered into the following provisions:

During the performance of this contract, the contractor agrees as follows:

- (1) The contractor will not discriminate against any employee or applicant for employment because of race, color, religion, sex, age or national origin;*
- (2) The contractor will state in all solicitations or advertisements for employees placed by or on behalf of the contractors that all qualified applicants will receive consideration for employment without regard to race, color, religion, sex, age or national origin;*
- (3) The contractor will post notices in conspicuous places, available to employees and applicants for employment, setting forth the provisions of the non-discrimination clauses required by this section; and*
- (4) The contractor will send a notice to each labor union or representative of workers with which he has a collective bargaining agreement or other contract or understanding advising the labor union or workers' representative of the contractor's commitments under the nondiscrimination clauses.*

The Act further provides:

KRS 45.610. Hiring minorities - Information required

- (1) For the length of the contract, each contractor shall hire minorities from other sources within the drawing area, should the union with which he has collective bargaining agreements be unwilling to supply sufficient minorities to satisfy the agreed upon goals and timetable.*
- (2) Each contractor shall, for the length of the contract, furnish such information as required by KRS 45.560 to KRS 45.640 and by such rules, regulations and orders issued pursuant thereto and will permit access to all books and records pertaining to his employment practices and work sites by the contracting agency and the department for purposes of investigation to ascertain compliance with KRS 45.560 to 45.640 and such rules, regulations and orders issued pursuant thereto.*

KRS 45.620. Action against contractor - Hiring of minority contractor or subcontractor

- (1) If any contractor is found by the department to have engaged in an unlawful practice under this chapter during the course of performing under a contract or subcontract covered under KRS 45.560 to 45.640, the department shall so certify to the contracting agency and such certification shall be binding upon the contracting agency unless it is reversed in the course of judicial review.*
- (2) If the contractor is found to have committed an unlawful practice under KRS 45.560 to 45.640, the contracting agency may cancel or terminate the contract, conditioned upon a program for future compliance approved by the contracting agency and the department. The contracting agency may declare such a contractor ineligible to bid on further contracts with that agency until such time as the contractor complies in full with the requirements of KRS 45.560 to 45.640.*

- (3) *The equal employment provisions of KRS 45.560 to 45.640 may be met in part by a contractor by subcontracting to a minority contractor or subcontractor. For the provisions of KRS 45.560 to 45.640, a minority contractor or subcontractor shall mean a business that is owned and controlled by one or more persons disadvantaged by racial or ethnic circumstances.*

KRS 45.630 Termination of existing employee not required, when

Any provision of KRS 45.560 to 45.640 notwithstanding, no contractor shall be required to terminate an existing employee upon proof that that employee was employed prior to the date of the contract.

KRS 45.640 Minimum skills

Nothing in KRS 45.560 to 45.640 shall require a contractor to hire anyone who fails to demonstrate the minimum skills required to perform a particular job.

It is recommended that all of the provisions above quoted to be included as special conditions in each contract. In the case of a contract exceeding \$250,000, the contractor is required to furnish evidence that his work-force in Kentucky is representative of the available work-force in the area from which he draws employees, or to supply an Affirmative Action plan which will achieve such representation during the life of the contract.

- U. Any party, firm or individual submitting a proposal pursuant to this invitation must be in compliance with the requirements of the Lexington-Fayette Urban County Government regarding taxes and fees before they can be considered for award of this invitation and must maintain a "current" status with regard to those taxes and fees throughout the term of the contract. The contractor must be in compliance with Chapter 13 from the Code of Ordinances of the Lexington-Fayette Urban County Government. The contractor must be in compliance with Ordinance 35-2000 pursuant to contractor registration with the Division of Building Inspection. If applicable, said business must have a Fayette County business license.

Pursuant to KRS 45A.343 and KRS 45A.345, the contractor shall

- (1) *Reveal any final determination of a violation by the contractor within the previous five year period pursuant to KRS Chapters 136 (corporation and utility taxes), 139 (sales and use taxes), 141 (income taxes), 337 (wages and hours), 338 (occupational safety and health of employees), 341 (unemployment and compensation) and 342 (labor and human rights) that apply to the contractor; and*
- (2) *Be in continuous compliance with the above-mentioned KRS provisions that apply to the contractor for the duration of the contract.*

A contractor's failure to reveal the above or to comply with such provisions for the duration of the contract shall be grounds for cancellation of the contract and disqualification of the contractor from eligibility for future contracts for a period of two (2) years.

- V. Vendors who respond to this invitation have the right to file a notice of contention associated with the bid process or to file a notice of appeal of the recommendation made by the Director of Central Purchasing resulting from this invitation.

Notice of contention with the bid process must be filed within 3 business days of the bid/proposal opening by (1) sending a written notice, including sufficient documentation to support contention, to the Director of the Division of Central Purchasing or (2) submitting a written request for a meeting with the Director of Central Purchasing to explain his/her contention with the bid process. After consulting with the Commissioner of Finance the Chief Administrative Officer and reviewing the documentation and/or hearing the vendor, the Director of Central Purchasing shall promptly respond in writing findings as to the compliance with bid processes. If, based on this review, a bid process irregularity is deemed to have occurred the Director of Central Purchasing will consult with the Commissioner of Finance, the Chief Administrative Officer and the Department of Law as to the appropriate remedy.

Notice of appeal of a bid recommendation must be filed within 3 business days of the bid recommendation by (1) sending a written notice, including sufficient documentation to support appeal, to the Director, Division of Central Purchasing or (2) submitting a written request for a meeting with the Director of Central Purchasing to explain his appeal. After reviewing the documentation and/or hearing the vendor and consulting with the Commissioner of Finance and the Chief Administrative Officer, the Director of Central Purchasing shall in writing, affirm or withdraw the recommendation.

LFUCG Non-Appropriation Clause

Contractor acknowledges that the LFUCG is a governmental entity, and the contract validity is based upon the availability of public funding under the authority of its statutory mandate.

In the event that public funds are unavailable and not appropriated for the performance of the LFUCG's obligations under this contract, then this contract shall automatically expire without penalty to the LFUCG thirty (30) days after written notice to Contractor of the unavailability and non-appropriation of public funds. It is expressly agreed that the LFUCG shall not activate this non-appropriation provision for its convenience or to circumvent the requirements of this contract, but only as an emergency fiscal measure during a substantial fiscal crisis, which affects generally its governmental operations.

In the event of a change in the LFUCG's statutory authority, mandate and mandated functions, by state and federal legislative or regulatory action, which adversely affects the LFUCG's authority to continue its obligations under this contract, then this contract shall automatically terminate without penalty to the LFUCG upon written notice to Contractor of such limitation or change in the LFUCG's legal authority.

SPECIAL INSTRUCTIONS TO THE BIDDER

(DO NOT SUBMIT PERFORMANCE SECURITY WITH BID)

Performance Security: The APPARENT LOW BIDDER shall furnish, before recommendation by the Division of Central Purchasing to the Urban County Council that the BIDDER'S bid be accepted, a Performance Bond, Certified Check or Cashier's Check, payable to the Lexington-Fayette Urban County Government, in the penal sum of 100% of the price of the materials and/or services proposed in the bid.

The performance bond will not be returned to the bidder after delivery of the materials/services specified herein unless the bidder requests that the performance bond be returned.

The certified / cashier's check will be returned when the materials and/or services specified herein have been delivered.

In the event of bidder's failure to perform as specified herein, it is agreed that the monies represented by the performance bond or certified / cashier's check shall be retained by the Lexington-Fayette Urban County Government as liquidated damages.

Contracts that are less than \$50,000 will not require a 5% bid security or a performance and payment bond.

EQUAL OPPORTUNITY AGREEMENT

The Law

- Title VII of the Civil Rights Act of 1964 (amended 1972) states that it is unlawful for an employer to discriminate in employment because of race, color, religion, sex, age (40-70 years) or national origin.
- Executive Order No. 11246 on Nondiscrimination under Federal contract prohibits employment discrimination by contractor and sub-contractor doing business with the Federal Government or recipients of Federal funds. This order was later amended by Executive Order No. 11375 to prohibit discrimination on the basis of sex.
- Section 503 of the Rehabilitation Act of 1973 states:

The Contractor will not discriminate against any employee or applicant for employment because of physical or mental disability.

- Section 2012 of the Vietnam Era Veterans Readjustment Act of 1973 requires Affirmative Action on behalf of disabled veterans and veterans of the Vietnam Era by contractors having Federal contracts.
- Section 206(A) of Executive Order 12086, Consolidation of Contract Compliance Functions for Equal Employment Opportunity, states:

The Secretary of Labor may investigate the employment practices of any Government contractor or sub-contractor to determine whether or not the contractual provisions specified in Section 202 of this order have been violated.

The Lexington-Fayette Urban County Government practices Equal Opportunity in recruiting, hiring and promoting. It is the Government's intent to affirmatively provide employment opportunities for those individuals who have previously not been allowed to enter into the mainstream of society. Because of its importance to the local Government, this policy carries the full endorsement of the Mayor, Commissioners, Directors and all supervisory personnel. In following this commitment to Equal Employment Opportunity and because the Government is the benefactor of the Federal funds, it is both against the Urban County Government policy and illegal for the Government to let contracts to companies which knowingly or unknowingly practice discrimination in their employment practices. Violation of the above mentioned ordinances may cause a contract to be canceled and the contractors may be declared ineligible for future consideration.

Please sign this statement in the appropriate space acknowledging that you have read and understand the provisions contained herein. Return this document as part of your application packet.

Bidders

I/We agree to comply with the Civil Rights Laws listed above that govern employment rights of minorities, women, veteran status, disability and age.

Signature 

HERITAGE INSTALLATIONS I, LLC DBA RENEWAL
Name of Business BY ANDERSEN

GENERAL PROVISIONS OF BID CONTRACT

By signing the below, bidder acknowledges that it understands and agrees with the following provisions related to its bid response and the provision of any goods or services to LFUCG upon selection by LFUCG pursuant to the bid request:

1. Bidder shall comply with all Federal, State & Local regulations concerning this type of service or good.
2. Failure to submit ALL forms and information required by LFUCG may be grounds for disqualification.
3. Addenda: All addenda, if any, must be considered by the bidder in making its response, and such addenda shall be made a part of the requirements of the bid contract. Before submitting a bid response, it is incumbent upon bidder to be informed as to whether any addenda have been issued, and the failure of the bidder to cover any such addenda may result in disqualification of that response.
4. Bid Reservations: LFUCG reserves the right to reject any or all bid responses, to award in whole or part, and to waive minor immaterial defects in proposals. LFUCG may consider any alternative proposal that meets its basic needs.
5. Liability: LFUCG is not responsible for any cost incurred by bidder in the preparation of its response.
6. Changes/Alterations: Bidder may change or withdraw a proposal at any time prior to the opening; however, no oral modifications will be allowed. Only letters, or other formal written requests for modifications or corrections of a previously submitted proposal which is addressed in the same manner as the bid response, and received by LFUCG prior to the scheduled closing time for receipt of bids, will be accepted. The bid response when opened, will then be corrected in accordance with such written request(s), provided that the written request is contained in a sealed envelope which is plainly marked "modifications of bid response".
7. Clarification of Submittal: LFUCG reserves the right to obtain clarification of any point in a bid or to obtain additional information from any bidder.
8. Bribery Clause: By his/her signature on its response, bidder certifies that no employee of his/hers, any affiliate or subcontractor, has bribed or attempted to bribe an officer or employee of the LFUCG.
9. Additional Information: While not necessary, the bidder may include any product brochures, software documentation, sample reports, or other documentation that may assist LFUCG in better understanding and evaluating the bid response. Additional documentation shall not serve as a substitute for other documentation which is required by the LFUCG to be submitted with the bid response.
10. Ambiguity, Conflict or other Errors: If a bidder discovers any ambiguity, conflict, discrepancy, omission or other error in the bid request of LFUCG, it shall immediately notify LFUCG of such error in writing and request modification or clarification of the document if allowable by the LFUCG.
11. Agreement to Bid Terms: In submitting its bid response, the bidder agrees that it has carefully examined the specifications and all provisions relating to LFUCG's bid request, including but not limited to the bid contract. By submission of its bid response, bidder states that it understands the meaning, intent and requirements of LFUCG's bid request and agrees to the same. The successful bidder shall warrant that it is familiar with and understands all provisions herein and shall warrant that it can comply with them. No additional compensation to bidder shall be authorized for services, expenses, or goods reasonably covered under these provisions that the bidder omits from its bid response.
12. Cancellation: LFUCG may unilaterally terminate the bid contract with the selected bidder(s) at any time, with or without cause, by providing at least thirty (30) days advance written notice unless a different advance written notice period is negotiated prior to contract approval. Payment for services or goods received prior to termination shall be made by the LFUCG provided these goods or services were provided in a manner acceptable to the LFUCG. Payment for those goods and services shall not be unreasonably withheld.

13. Assignment of Contract: The selected bidder(s) shall not assign or subcontract any portion of the bid contract with LFUCG without the express written consent of LFUCG. Any purported assignment or subcontract in violation hereof shall be void. It is expressly acknowledged that LFUCG shall never be required or obligated to consent to any request for assignment or subcontract; and further that such refusal to consent can be for any or no reason, fully within the sole discretion of LFUCG.
14. No Waiver: No failure or delay by LFUCG in exercising any right, remedy, power or privilege hereunder, nor any single or partial exercise thereof, nor the exercise of any other right, remedy, power or privilege shall operate as a waiver hereof or thereof. No failure or delay by LFUCG in exercising any right, remedy, power or privilege under or in respect of this bid proposal or bid contract shall affect the rights, remedies, powers or privileges of LFUCG hereunder or shall operate as a waiver thereof.
15. Authority to do Business: Each bidder must be authorized to do business under the laws of the Commonwealth of Kentucky and must be in good standing and have full legal capacity to provide the goods or services specified in the bid proposal. Each bidder must have all necessary right and lawful authority to submit the bid response and enter into the bid contract for the full term hereof including any necessary corporate or other action authorizing the bidder to submit the bid response and enter into this bid contract. If requested, the bidder will provide LFUCG with a copy of a corporate resolution authorizing this action and/or a letter from an attorney confirming that the proposer is authorized to do business in the Commonwealth of Kentucky. All bid responses must be signed by a duly authorized officer, agent or employee of the bidder.
16. Governing Law: This bid request and bid contract shall be governed by and construed in accordance with the laws of the Commonwealth of Kentucky. In the event of any proceedings regarding this matter, the bidder agrees that the venue shall be the Fayette County Circuit Court or the U.S. District Court for the Eastern District of Kentucky, Lexington Division and that the bidder expressly consents to personal jurisdiction and venue in such Court for the limited and sole purpose of proceedings relating to these matters or any rights or obligations arising thereunder.
17. Ability to Meet Obligations: Bidder affirmatively states that there are no actions, suits or proceedings of any kind pending against bidder or, to the knowledge of the bidder, threatened against the bidder before or by any court, governmental body or agency or other tribunal or authority which would, if adversely determined, have a materially adverse effect on the authority or ability of bidder to perform its obligations under this bid response or bid contract, or which question the legality, validity or enforceability hereof or thereof.
18. Bidder understands and agrees that its employees, agents, or subcontractors are not employees of LFUCG for any purpose whatsoever. Bidder is an independent contractor at all times related to the bid response or bid contract.
19. If any term or provision of this bid contract shall be found to be illegal or unenforceable, the remainder of the contract shall remain in full force and such term or provision shall be deemed stricken.

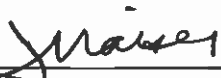

Signature

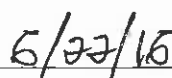

Date

Lexington-Fayette Urban County Government
Division Facilities Management
Bid #87-2016 Replacement Windows for Artsplace

The Lexington-Fayette Urban County Government is accepting bids for Replacement Windows for Artsplace as per the following specifications:

Notes to Contractors:

Contractor Responsibilities

The contractor warrants, by submission of his/her bid, that all components of the windows shall be of the kind and quality necessary to assure that the performance of the equipment will meet or exceed the published specifications.

Scope of Work

- Project Identification: Project consists of new windows for the 4th floor of Artsplace an LFUCG Facility.
- Project Location: Artsplace 161 Mill Street, Lexington, KY 40507
- Owner: Lexington Fayette Urban County Government, 200 East Main Street, Lexington, KY 40507
- Project Coordinator: Mark A. Arnold of Facilities Management. All questions pre-bid will need to be directed to Conni M. Hayes (859)258-3326
- This is for windows only not installation. See plans that have been provided. The contractor will need to field verify windows after they have been awarded the project.

Pre-Bid Site Visits

A pre-bid conference will be held June 15, 2016 at 11:00 am at 151 Mill St., Lexington KY 40507. All prospective bidders are encouraged to attend.

Pricing:

ITEM	UNIT PRICE EACH	TOTAL PRICE
<u>Windows</u>	SEE ATTACHED \$ ITEMIZATION	\$ 21,882.00



SITE PLAN

Limited Window Replacement ArtsPlace Building

161 North Mill Street
Lexington, KY 40508

Owner: Lexington-Urban County Government
General Services
200 East Main Street
Lexington, KY 40508

Drawings

Cover

- A 1 Plans, Details, Schedules
- A 2 Elevation Photographs

FITZSIMONS OFFICE OF ARCHITECTURE, INC.
Lexington, KY 40508
Tel 603-220-0000
Fax 603-220-0203

ArtsPlace Building
161 North Mill Street
Lexington, Kentucky

DATE	BY
PROJECT	SCALE
DESCRIPTION	NO.
REVISIONS	
1	
2	

Cover

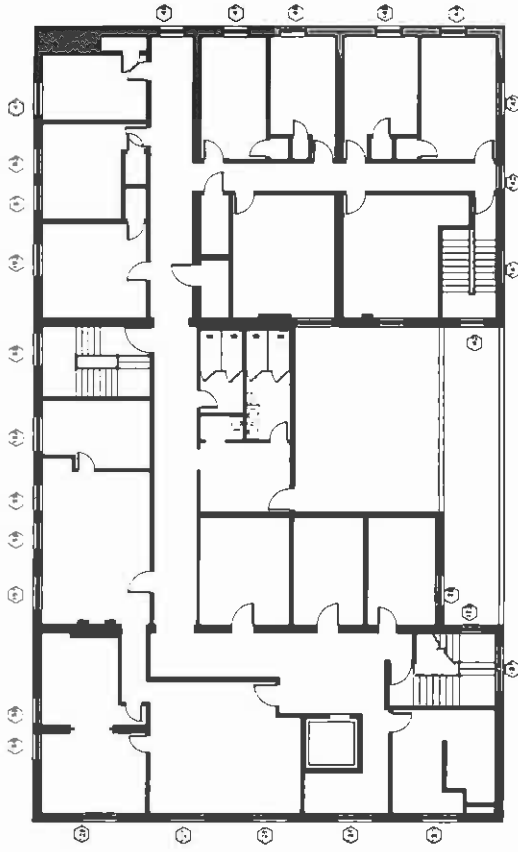

1. FOURTH FLOOR PLAN
 SCALE 1/8" = 1'-0"

NOTES:
 1. Window Schedule is for replacement windows. All window and door openings are to be replaced with windows. Existing windows and doors are to be replaced with windows. All window and door openings are to be replaced with windows. All window and door openings are to be replaced with windows.

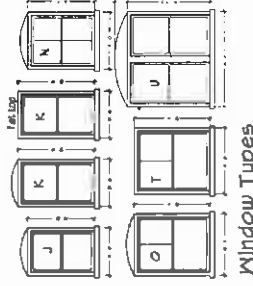

Window Types

NO.	TYPE	QTY	SIZE	FINISH	GLASS	OPERATION	MARKING	REMARKS
101	1	1	36" x 48"	White	Clear	Fixed	101	101
102	2	2	36" x 48"	White	Clear	Fixed	102	102
103	3	3	36" x 48"	White	Clear	Fixed	103	103
104	4	4	36" x 48"	White	Clear	Fixed	104	104
105	5	5	36" x 48"	White	Clear	Fixed	105	105
106	6	6	36" x 48"	White	Clear	Fixed	106	106
107	7	7	36" x 48"	White	Clear	Fixed	107	107
108	8	8	36" x 48"	White	Clear	Fixed	108	108
109	9	9	36" x 48"	White	Clear	Fixed	109	109
110	10	10	36" x 48"	White	Clear	Fixed	110	110
111	11	11	36" x 48"	White	Clear	Fixed	111	111
112	12	12	36" x 48"	White	Clear	Fixed	112	112
113	13	13	36" x 48"	White	Clear	Fixed	113	113
114	14	14	36" x 48"	White	Clear	Fixed	114	114
115	15	15	36" x 48"	White	Clear	Fixed	115	115
116	16	16	36" x 48"	White	Clear	Fixed	116	116
117	17	17	36" x 48"	White	Clear	Fixed	117	117
118	18	18	36" x 48"	White	Clear	Fixed	118	118
119	19	19	36" x 48"	White	Clear	Fixed	119	119
120	20	20	36" x 48"	White	Clear	Fixed	120	120
121	21	21	36" x 48"	White	Clear	Fixed	121	121
122	22	22	36" x 48"	White	Clear	Fixed	122	122
123	23	23	36" x 48"	White	Clear	Fixed	123	123
124	24	24	36" x 48"	White	Clear	Fixed	124	124
125	25	25	36" x 48"	White	Clear	Fixed	125	125
126	26	26	36" x 48"	White	Clear	Fixed	126	126
127	27	27	36" x 48"	White	Clear	Fixed	127	127
128	28	28	36" x 48"	White	Clear	Fixed	128	128
129	29	29	36" x 48"	White	Clear	Fixed	129	129
130	30	30	36" x 48"	White	Clear	Fixed	130	130

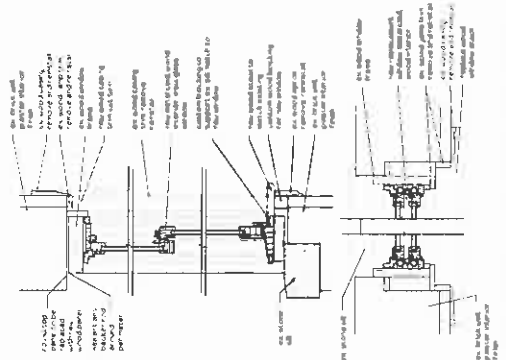

2. REPLACE WINDOW DET.
 SCALE 1/2" = 1'-0"

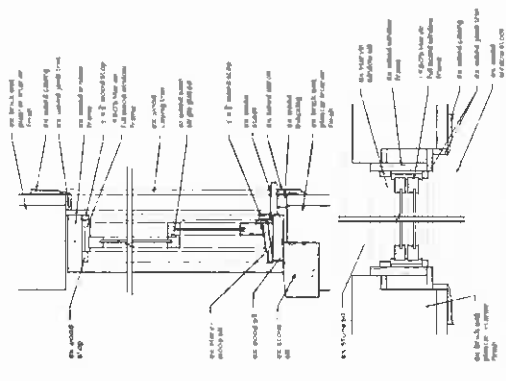

3. EXISTING WINDOW DETAILS
 SCALE 1/2" = 1'-0"

Date:	01.10.13
Project:	
Client:	
Architect:	
Scale:	
Sheet:	

Exterior Elevations

A2



1 SOUTH ELEVATION

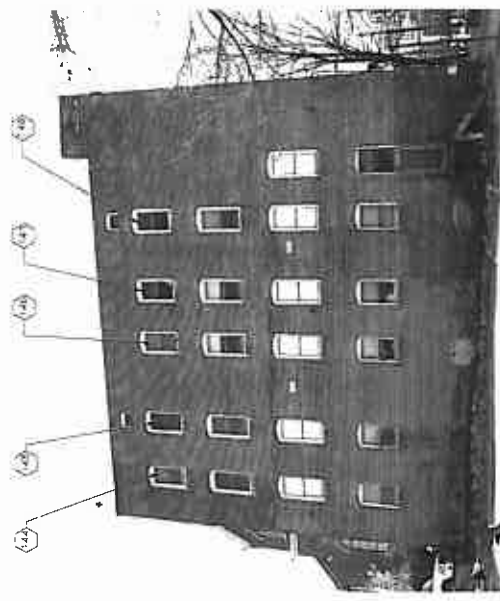

3 WEST ELEVATION



2 NORTH ELEVATION



4 EAST ELEVATION

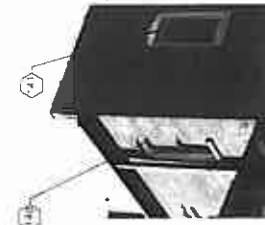

5 INSET E. ELEV.

**RISK MANAGEMENT PROVISIONS
INSURANCE AND INDEMNIFICATION
Bid #87-2016 Replacement Windows for Artsplace**

INDEMNIFICATION AND HOLD HARMLESS PROVISION

- (1) It is understood and agreed by the parties that Vendor hereby assumes the entire responsibility and liability for any and all damages to persons or property caused by or resulting from or arising out of any act or omission on the part of Vendor or its employees, agents, servants, owners, principals, licensees, assigns or subcontractors of any tier (hereinafter "Vendor") under or in connection with this agreement and/or the provision of goods or services and the performance or failure to perform any work required thereby.
- (2) Vendor shall indemnify, save, hold harmless and defend the Lexington-Fayette Urban County Government and its elected and appointed officials, employees, agents, volunteers, and successors in interest (hereinafter "LFUCG") from and against all liability, damages, and losses, including but not limited to, demands, claims, obligations, causes of action, judgments, penalties, fines, liens, costs, expenses, interest, defense costs and reasonable attorney's fees that are in any way incidental to or connected with, or that arise or are alleged to have arisen, directly or indirectly, from or by Vendor's performance or breach of the agreement and/or the provision of goods or services provided that: (a) it is attributable to personal injury, bodily injury, sickness, or death, or to injury to or destruction of property (including the loss of use resulting therefrom), or to or from the negligent acts, errors or omissions or willful misconduct of the Vendor; and (b) not caused solely by the active negligence or willful misconduct of LFUCG.
- (3) In the event LFUCG is alleged to be liable based upon the above, Vendor shall defend such allegations and shall bear all costs, fees and expenses of such defense, including but not limited to, all reasonable attorneys' fees and expenses, court costs, and expert witness fees and expenses, using attorneys approved in writing by LFUCG, which approval shall not be unreasonably withheld.
- (4) These provisions shall in no way be limited by any financial responsibility or insurance requirements, and shall survive the termination of this agreement.
- (5) LFUCG is a political subdivision of the Commonwealth of Kentucky. Vendor acknowledges and agrees that LFUCG is unable to provide indemnity or otherwise save, hold harmless, or defend the Vendor in any manner.

FINANCIAL RESPONSIBILITY

Vendor understands and agrees that it shall, prior to final acceptance of its bid and the commencement of any work, demonstrate the ability to assure compliance with the above Indemnity provisions and these other risk management provisions.

INSURANCE REQUIREMENTS

YOUR ATTENTION IS DIRECTED TO THE INSURANCE REQUIREMENTS BELOW, AAND YOU MAY NEED TO CONFER WITH YOUR INSURANCE AGENTS, BROKERS, OR CARRIERS TO DETERMINE IN ADVANCE OF SUBMISSION OF A RESPONSE THE AVAILABILITY OF THE INSURANCE COVERAGES AND ENDORSEMENTS REQUIRED HEREIN. IF YOU FAIL TO COMPLY WITH THE INSURANCE REQUIREMENTS BELOW, YOU MAY BE DISQUALIFIED FROM AWARD OF THE CONTRACT.

Required Insurance Coverage

Vendor shall procure and maintain for the duration of this contract the following or equivalent insurance policies at no less than the limits shown below and cause its subcontractors to maintain similar insurance with limits acceptable to LFUCG in order to protect LFUCG against claims for injuries to persons or damages to property which may arise from or in connection with the performance of the work or provision of goods hereunder by Vendor. The cost of such insurance shall be included in any bid:

<u>Coverage</u>	<u>Limits</u>
General Liability (Insurance Services Office Form CG 00 01)	\$1 million per occurrence, \$2 million aggregate or \$2 million combined single limit
Commercial Automobile Liability (Insurance Services Office Form CA 0001)	combined single, \$1 million per occurrence
Worker's Compensation	Statutory
Employer's Liability	\$500,000.00

The policies above shall contain the following conditions:

- a. All Certificates of Insurance forms used by the insurance carrier shall be properly filed and approved by the Department of Insurance for the Commonwealth of Kentucky. LFUCG shall be named as an additional insured in the General Liability Policy and Commercial Automobile Liability Policy using the Kentucky DOI approved forms.
- b. The General Liability Policy shall be primary to any insurance or self-insurance retained by LFUCG.
- c. LFUCG shall be provided at least 30 days advance written notice via certified mail, return receipt requested, in the event any of the required policies are canceled or non-renewed.
- d. The General Liability Policy shall include a Products Liability endorsement unless deemed not to apply by LFUCG.
- e. Said coverage shall be written by insurers acceptable to LFUCG and shall be in a form acceptable to LFUCG. Insurance placed with insurers with a rating classification of no less than Excellent (A or A-) and a financial size category of no less than VIII, as defined by the most current Best's Key Rating Guide shall be deemed automatically acceptable.

Renewals

After insurance has been approved by LFUCG, evidence of renewal of an expiring policy must be submitted to LFUCG, and may be submitted on a manually signed renewal endorsement form. If the policy or carrier has changed, however, new evidence of coverage must be submitted in accordance with these Insurance Requirements.

Deductibles and Self-Insured Programs

IF YOU INTEND TO SUBMIT A SELF-INSURANCE PLAN IT MUST BE FORWARDED TO LEXINGTON-FAYETTE URBAN COUNTY GOVERNMENT, DIVISION OF RISK MANAGEMENT, 200 EAST MAIN STREET, LEXINGTON, KENTUCKY 40507 NO LATER THAN

A MINIMUM OF FIVE (5) WORKING DAYS PRIOR TO THE RESPONSE DATE. Self-insurance programs, deductibles, and self-insured retentions in insurance policies are subject to separate approval by Lexington-Fayette Urban County Government's Division of Risk Management, upon review of evidence of Vendor's financial capacity to respond to claims. Any such programs or retentions must provide LFUCG with at least the same protection from liability and defense of suits as would be afforded by first-dollar insurance coverage. If Vendor satisfies any portion of the insurance requirements through deductibles, self-insurance programs, or self-insured retentions, Vendor agrees to provide Lexington-Fayette Urban County Government, Division of Risk Management, the following data prior to the final acceptance of bid and the commencement of any work:

- a. Latest audited financial statement, including auditor's notes.
- b. Any records of any self-insured trust fund plan or policy and related accounting statements.
- c. Actuarial funding reports or retained losses.
- d. Risk Management Manual or a description of the self-insurance and risk management program.
- e. A claim loss run summary for the previous five (5) years.
- f. Self-Insured Associations will be considered.

Verification of Coverage

Vendor agrees to furnish LFUCG with all applicable Certificates of Insurance signed by a person authorized by the insurer to bind coverage on its behalf prior to final award, and if requested, shall provide LFUCG copies of all insurance policies, including all endorsements.

Right to Review, Audit and Inspect

Vendor understands and agrees that LFUCG may review, audit and inspect any and all of its records and operations to insure compliance with these Insurance Requirements.

DEFAULT

Vendor understands and agrees that the failure to comply with any of these insurance, safety, or loss control provisions shall constitute default and that LFUCG may elect at its option any single remedy or penalty or any combination of remedies and penalties, as available, including but not limited to purchasing insurance and charging Vendor for any such insurance premiums purchased, or suspending or terminating the work.

00471584

MAYOR JIM GRAY



LEXINGTON

TODD SLATIN
DIRECTOR
CENTRAL PURCHASING

ADDENDUM #1

Bid Number: 87-2016

Date: June 16, 2016

Subject: Replacement Windows for ArtsPlace

Please address inquiries to:

Conni Hayes, Buyer
(859) 258-3320

TO ALL PROSPECTIVE BIDDERS:

Please be advised of the following clarifications to the above referenced bid:

- 1) Attached is the sign-in sheet from the pre-bid meeting.

Todd Slatin, Director
Division of Central Purchasing

All other terms and conditions of the Bid and specifications are unchanged. This letter should be signed, attached to and become a part of your Bid.

COMPANY NAME: HERITAGE INSTALLATIONS I, LLC DBA RENEWAL BY ANDERSEN

ADDRESS: 11400 BLUEGRASS PKWY., LOUISVILLE, KY 40299

SIGNATURE OF BIDDER:



MAYOR JIM GRAY



LEXINGTON

TODD SLATIN
DIRECTOR
CENTRAL PURCHASING

ADDENDUM #2

Bid Number: 87-2016

Date: June 20, 2016

Subject: Installation of LED Fixtures

Please address inquiries to:

**Conni Hayes, Buyer
(859) 258-3320**

TO ALL PROSPECTIVE BIDDERS:

Please be advised of the following clarifications to the above referenced bid:

The following are questions and answers from the pre-bid meeting held June 15, 2016.

Window Schedule

Window no. 144 should be type K, not type O.

Window Types

Types N and J are not used in the window schedule, no windows of this type to be provided.

Window Color

Exterior metal to be standard white, interior to be factory primed in white.

Tempered Glass

Provide tempered glass for window 131, 132, 141.

Simulated Lite Divider Bar

Shall be black or dark bronze anodized aluminum



Todd Slatin

Todd Slatin, Director
Division of Central Purchasing

All other terms and conditions of the Bid and specifications are unchanged. This letter should be signed, attached to and become a part of your Bid.

COMPANY NAME: HERITAGE INSTALLATIONS I, LLC DBA RENEWAL BY ANDERSEN!

ADDRESS: 11400 BLUEGRASS PKWY., LOUISVILLE, KY 40299

SIGNATURE OF BIDDER: *J. Mauer*



ADDITIONAL PRODUCT/PRICE DETAILS
BID ON #87-2016 REPLACEMENT OF WINDOWS FOR ARTSPLACE
RENEWAL BY ANDERSEN

Product summary

- Andersen E-Series (Eagle) insert/replacement windows (also see enclosed brochure)
- Wood (pine) interiors with extruded aluminum exteriors
- Architecturally correct profiling
- Prefinished exteriors (white or other choice if desired from among 50 standard colors)
- Primed wood interiors
- Insulated glass with no Low E coatings as specified in pre-bid meeting (Low E available at no additional charge)
- Modern divided lights (i.e., permanently affixed interior and exterior grilles with spacer bar in between glass panes)
- Bronze hardware, with other choices available at no charge

Exception to bid specifications:

- All windows are double hung windows, meaning both sashes are operable and can be tilted in for cleaning. Single hung windows were specified but are not available in the requested construction (wood with extruded aluminum exterior). Single hung windows offer operation of the bottom sash only, along with limited ease of cleaning.

Unit pricing

- Window K – 15 units – \$658.80/unit
- Window K (tempered glass) – 2 units – \$839.00/unit
- Window O – 5 units – \$851.20/unit
- Window T – 5 units – \$851.20/unit
- Window U (tempered glass) – 1 two-wide unit – \$1,810/two-wide unit (\$905.00/single window)

Total project cost - \$21,882.00