

SECTION 00410A – BID FORM

West Hickman 7 (WH7) Wet Weather Storage Facilities Improvements

Contract No. 1 New Circle Road Crossing

Division of Water Quality
Lexington-Fayette Urban County Government

LFUCG Bid No. ~~80-2017~~

1.01 GENERAL

Place: Lexington, Kentucky

Date: 6-27-2017

The following Bid Form shall be followed exactly in submitting a Bid for this Work.

This Bid Form Submitted by Midwest Mole Inc.
6814 W 350 N, Greenfield, IN 46140
(Name and Address of Bidder)

(Hereinafter called "Bidder"), organized and existing under the laws of the State of INDIANA, doing business as a Corporation
"a corporation," "a partnership", or an "individual" as applicable

To: Lexington-Fayette Urban County Government
(Hereinafter called "Owner")
Office of the Director of Central Purchasing
200 East Main Street, Room 338
Lexington, KY 40507

The Bidder, in compliance with your Advertisement for Bids for the **WH7 Wet Weather Storage - Contract No. 1 New Circle Road Crossing**; Lexington, Kentucky, having examined the Contract Documents including the Plans and Specifications with related documents, having examined the site for proposed Work, and being familiar with all of the conditions and any and all addendums surrounding the construction of the proposed Project, including the availability of materials and labor, hereby proposes to furnish all labor, materials, and supplies, and to construct the Project in accordance with the Contract Documents, within the time set forth therein, and at the lump sum] stated hereinafter. These prices are to cover all expenses incurred in performing the Work required under the Contract Documents, of which this Bid is a part. This bid includes the Pump Station, Pump Station site work and access road.

The Bidder hereby agrees to commence Work under this Contract on a date to be specified in a written "Notice to Proceed" of the Owner and to substantially complete the Project within 120 consecutive calendar days. Bidder further agrees to pay liquidated damages, the sum of eight hundred dollars and no cents (\$500.00) for each consecutive day thereafter.

The Bidder hereby acknowledges receipt of the following addenda:

- Addendum No. #1 Date 6/15/2017; Addendum No. Date
- Addendum No. #2 Date 6/20/2017; Addendum No. Date
- Addendum No. #3 Date 6/21/2017; Addendum No. Date
- Addendum No. Date ; Addendum No. Date



ADDENDUM #1

Bid Number: #80-2017

Date: June 15, 2017

Subject: WH7 Wet Weather Storage Improvements-
New Circle Road CrossingAddress inquiries to:
Brian Marcum
(859) 258-3320

TO ALL PROSPECTIVE SUBMITTERS:

Please be advised of the following clarifications to the above referenced bid:

	Questions	Answers
1	Will Resident Project Representative (RPR) overtime charges be applied to this project?	LFUCG will not assess reasonable RPR overtime charges to the Contractor.
2	Can the Contractor use the available city property to stage construction activities?	Yes. Contractor can use the Pump Station site and the Ground Storage Tank site for construction staging. Contractor shall submit proposed staging areas for approval by Owner and Engineer.
3	Can the "rescue pit" be added as a separate bid item?	The rescue pit is shown on the drawings as a possible location in the KYTC permit request. If the Contractor does not need to retrieve equipment then it will not be used. A separate bid item is not needed.
4	Would LFUCG entertain the installation of the 60" casing/liner plate using drill and blast, hand mine tunneling	Yes



	method?	
5	What type of backfill is required at the bore pits?	Backfill shall meet the requirements of Specification Section 02200 (included in Addendum No. 1). Testing shall be provided and paid by the Owner.

SPECIFICATIONS

1. Section 00600, page 16: 1.h. blank shall be \$ 5,000,000.
 - i. Point of change is to include the amount of umbrella liability endorsement to the CGL policy.
2. Section 00800, page 13: 17.10 is deleted in its entirety.
3. Section 02200: Add the attached specification section 02200, Earthwork.
4. Section 02402, pages 11 and 12: Replace Section 02402 pages 11 and 12 with the attached 11 and 12.
 - i. Point of change was the Casing Insulators/Spacers (Rack) and Tolerances requirements.
5. Section 02531, page 1: Replace Section 02531, page 1 with the attached page 1.
 - i. Point of change is the requirement to require restrained joints and all pipe ends to be capped.
6. Section 02532, page 1: Replace Section 02532, page 1 with the attached page 1.
 - i. Point of change is the requirement for all pipe ends to be capped.

CLARIFICATIONS

1. Old KYTC plans from 1968 construction of the Lexington Circle Expressway (New Circle Road) at Richmond Road (US 25) are attached. All information is for informational purposes only.



Todd Slatin, Director
Division of Central Purchasing

All other terms and conditions of the RFP and specifications are unchanged. This letter should be signed, attached to and become a part of your submittal.



COMPANY NAME: Midwest Mole Inc.

ADDRESS: 6814 W 350N Greenfield, IN 46140

SIGNATURE OF BIDDER:  / Jason D Miller





ADDENDUM #2

Bid Number: #80-2017
Subject: WH7 Wet Weather Storage Improvements-
New Circle Road Crossing

Date: June 20, 2017

Address inquiries to:
Brian Marcum
(859) 258-3320

TO ALL PROSPECTIVE SUBMITTERS:

Please be advised of the following clarifications to the above referenced bid:

****Bid date has been extended to June 27, 2017 opening at 2:00 PM.****

	Questions	Answers
1	Can additional geotechnical information be provided?	Attached is additional geotechnical information (bore log) for Bore #3.

DRAWINGS

1. Sheet 01C-01 shall be revised by adding Note 6: Contractor shall replace 170 linear foot of the existing paved shoulder of the New Circle Road Exit Ramp per the attached Detail "S" upon the completion of work. Assume the shoulder width is a 7-foot paved shoulder and a 4-foot stabilized shoulder. The replacement of the shoulder is unclassified and shall be included in the base bid.
2. If surface damage occurs in the ramp lanes the surface shall be milled and paved. If structural damage occurs in the ramp lanes the entire pavement shall be removed and paved per the attached Detail "R". This includes pavement striping and shoulder rumble strip replacement. All



work and materials shall follow KYTC installation requirement and standards. All costs are unclassified and shall be included in the base bid. Determination of type of repair and area shall be determined by the Owner and Engineer.

- 3. Sheet 01C-01 shall be revised by adding Note 7: The traffic control plan, required in the General Notes, shall include a W21-5a sign (Right Shoulder Closed) set about 500 feet up the ramp from construction, a W21-7 sign (Utility Work Ahead) set about 250 feet up the ramp, and reflective cones (3 foot height) across the temporary entrance. All costs are unclassified and shall be included in the base bid.
- 4. Sheet 01C-01 shall be revised by adding Note 8: Construction/employee vehicles shall not be allowed to enter or exit the work site from the New Circle Road Exit Ramp weekdays between the hours of 7 to 9 am and 3 to 6 pm.
- 5. Sheet 01C-01 shall be revised by adding Note 9: The non-paved Right-of-Way (ROW) shall be restored to preconstruction contours at the conclusion of construction. Restoration shall be per Method B, General Notes, Non-paved Site Restoration. Erosion and sediment controls shall remain in place until the site is deemed 70% vegetated by the Engineer at which time the erosion and sediment controls shall be removed the Contractor.

CLARIFICATIONS

- 1. The Answer to Question 4 in Addendum No. 1 shall be revised as follows:
 - i. Yes, blasting is allowed but is restricted to hand mine tunneling only. Blasting will not be allowed for bore pits or other types of excavation.



Todd Slatin, Director
Division of Central Purchasing

All other terms and conditions of the RFP and specifications are unchanged. This letter should be signed, attached to and become a part of your submittal.

COMPANY NAME: Midwest Mole Inc.

ADDRESS: 6814 W 350 N, Greenfield, IN 46140

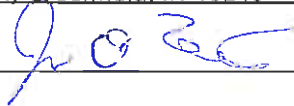
SIGNATURE OF BIDDER:  / Jason D Miller



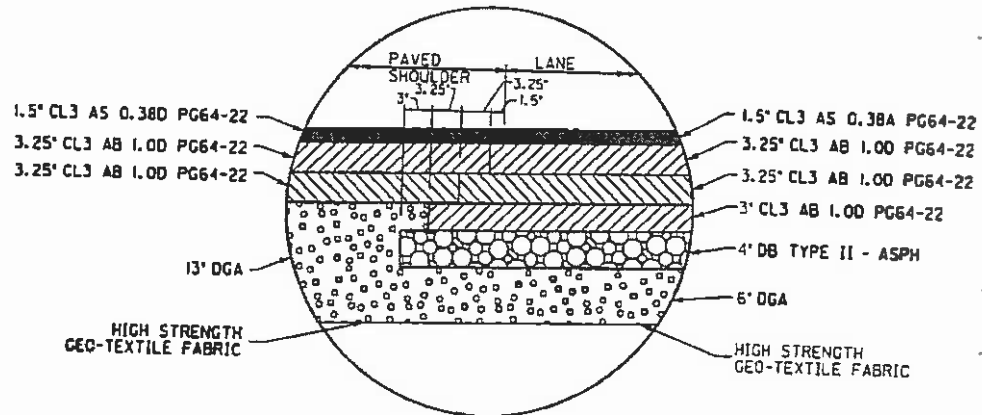

DETAIL "R"
NOT TO SCALE

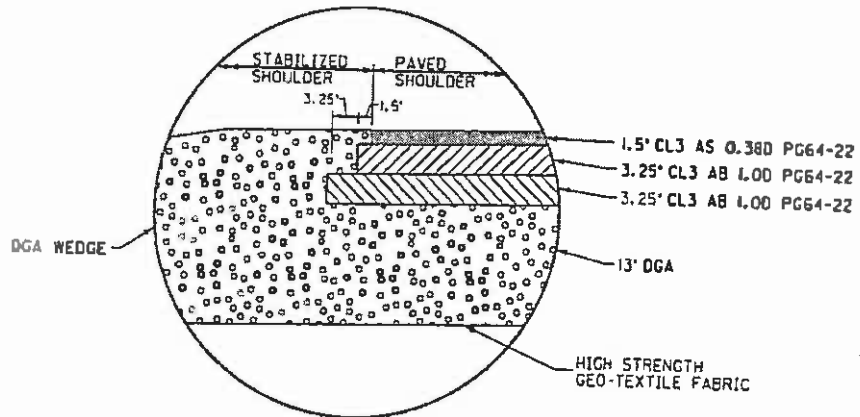

DETAIL "S"
NOT TO SCALE

Drilling

County: LA State: LA Project No.: 10015-001
 Project Name: 11112 Location: Completed
 Surface Elevation: 210 Date Started: 2/10/12
 Driller: ICA Logged By: Sheld
 Hole Number: 210 Total Depth: 210
 Drilling Method: 3125 TID Auger / Mud Rotary / Casing
 Depth to Water: Immediate
 Depth to Water: Immediate Date Measured: 2/10/12
 Casing Length: 210

Elev.	Depth	Strata Change	Description	Overburden	Sample No.	Run	Rec. (ft.)	Blows	Type
						0%			
			Auger 210			5.0	5.0		2.4
			Soil / Gravel with small stones		Run 1	6.0	6.0		3.4
			Soil coarse with clay seams		Run 2	6.0	6.0		4.5
			Soil limestone		Run 3	5.0	5.0		4.0
			Soil claystone with clay seams		Run 4	5.0	5.0		



ADDENDUM #3

Bid Number: #80-2017
Subject: WH7 Wet Weather Storage Improvements-
New Circle Road Crossing

Date: June 21, 2017

Address inquiries to:
Brian Marcum
(859) 258-3320

TO ALL PROSPECTIVE SUBMITTERS:

Please be advised of the following clarifications to the above referenced bid:

	Questions	Answers
1	Can additional geotechnical information be provided?	Attached is additional geotechnical information (bore logs with photographic record) for Bore #3A and #5A.

Todd Slatin, Director
Division of Central Purchasing

All other terms and conditions of the RFP and specifications are unchanged. This letter should be signed, attached to and become a part of your submittal.

COMPANY NAME: Midwest Mole Inc.

ADDRESS: 6814 W 350 N. Greenfield, IN 46140

SIGNATURE OF BIDDER: / Jason D Miller/ President



SOIL CLASSIFICATION CHART

MAJOR DIVISIONS			SYMBOLS		TYPICAL DESCRIPTIONS		
			GRAPH	LETTER			
<p>COARSE GRAINED SOILS</p> <p>MORE THAN 50% OF MATERIAL IS LARGER THAN NO. 200 SIEVE SIZE</p>	<p>GRAVEL AND GRAVELLY SOILS</p>	<p>CLEAN GRAVELS</p>		GW	WELL-GRADED GRAVELS, GRAVEL - SAND MIXTURES, LITTLE OR NO FINES		
		<p>(LITTLE OR NO FINES)</p>		GP	POORLY-GRADED GRAVELS, GRAVEL - SAND MIXTURES, LITTLE OR NO FINES		
		<p>MORE THAN 50% OF COARSE FRACTION RETAINED ON NO. 4 SIEVE</p>	<p>GRAVELS WITH FINES</p>		GM	SILTY GRAVELS, GRAVEL - SAND - SILT MIXTURES	
			<p>(APPRECIABLE AMOUNT OF FINES)</p>		GC	CLAYEY GRAVELS, GRAVEL - SAND - CLAY MIXTURES	
	<p>SAND AND SANDY SOILS</p>	<p>CLEAN SANDS</p>		SW	WELL-GRADED SANDS, GRAVELLY SANDS, LITTLE OR NO FINES		
			<p>(LITTLE OR NO FINES)</p>		SP	POORLY-GRADED SANDS, GRAVELLY SAND, LITTLE OR NO FINES	
		<p>MORE THAN 50% OF COARSE FRACTION PASSING ON NO. 4 SIEVE</p>	<p>SANDS WITH FINES</p>		SM	SILTY SANDS, SAND - SILT MIXTURES	
				<p>(APPRECIABLE AMOUNT OF FINES)</p>		SC	CLAYEY SANDS, SAND - CLAY MIXTURES
			<p>FINE GRAINED SOILS</p> <p>MORE THAN 50% OF MATERIAL IS SMALLER THAN NO. 200 SIEVE SIZE</p>	<p>SILTS AND CLAYS</p> <p>LIQUID LIMIT LESS THAN 50</p>		ML	INORGANIC SILTS AND VERY FINE SANDS, ROCK FLOUR, SILTY OR CLAYEY FINE SANDS OR CLAYEY SILTS WITH SLIGHT PLASTICITY
						CL	INORGANIC CLAYS OF LOW TO MEDIUM PLASTICITY, GRAVELLY CLAYS, SANDY CLAYS, SILTY CLAYS, LEAN CLAYS
	OL	ORGANIC SILTS AND ORGANIC SILTY CLAYS OF LOW PLASTICITY					
<p>SILTS AND CLAYS</p> <p>LIQUID LIMIT GREATER THAN 50</p>		MH		INORGANIC SILTS, MICACEOUS OR DIATOMACEOUS FINE SAND OR SILTY SOILS			
		CH		INORGANIC CLAYS OF HIGH PLASTICITY			
		OH		ORGANIC CLAYS OF MEDIUM TO HIGH PLASTICITY, ORGANIC SILTS			
<p>HIGHLY ORGANIC SOILS</p>				PT	PEAT, HUMUS, SWAMP SOILS WITH HIGH ORGANIC CONTENTS		

NOTE: DUAL SYMBOLS ARE USED TO INDICATE BORDERLINE SOIL CLASSIFICATIONS

CORE PHOTOGRAPHIC RECORD

West Hickman 7
Wet Weather Storage Improvements



B-3A - Box 1 of 3

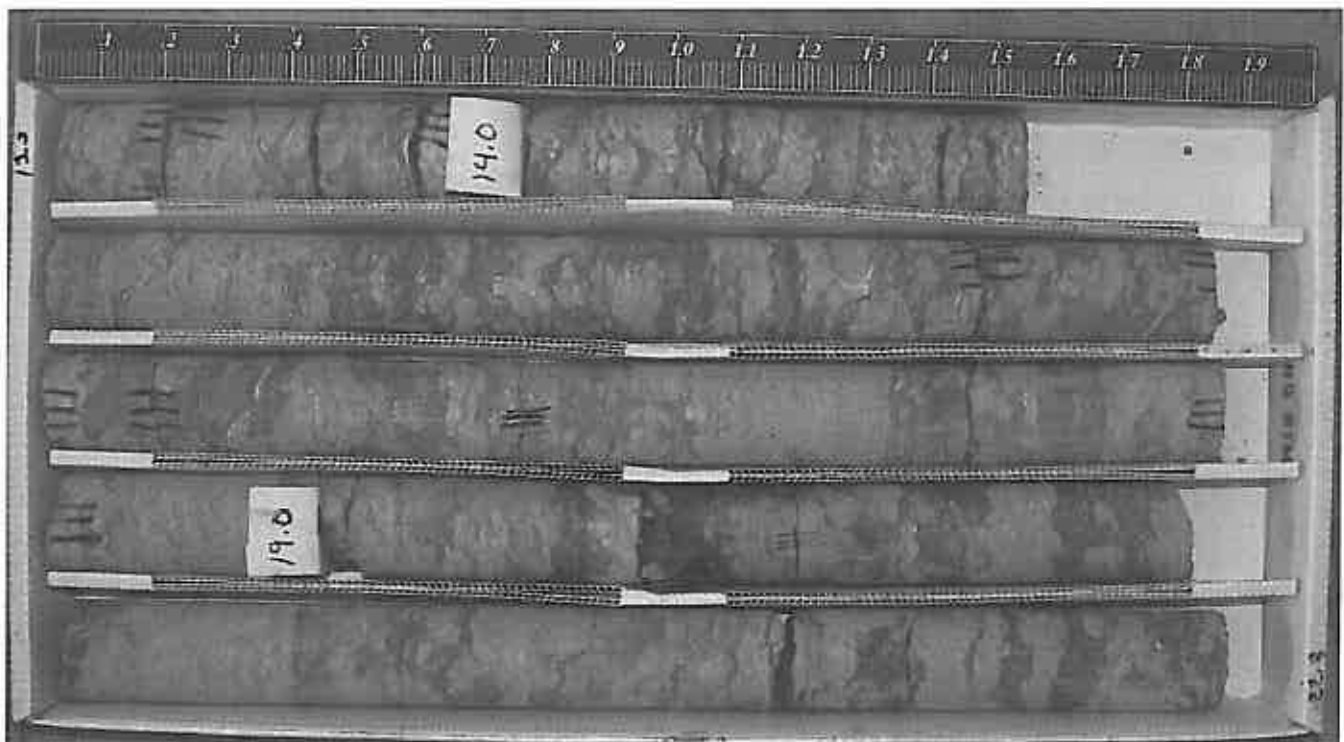

B-3A - Box 2 of 3

CORE PHOTOGRAPHIC RECORD

West Hickman 7
Wet Weather Storage Improvements

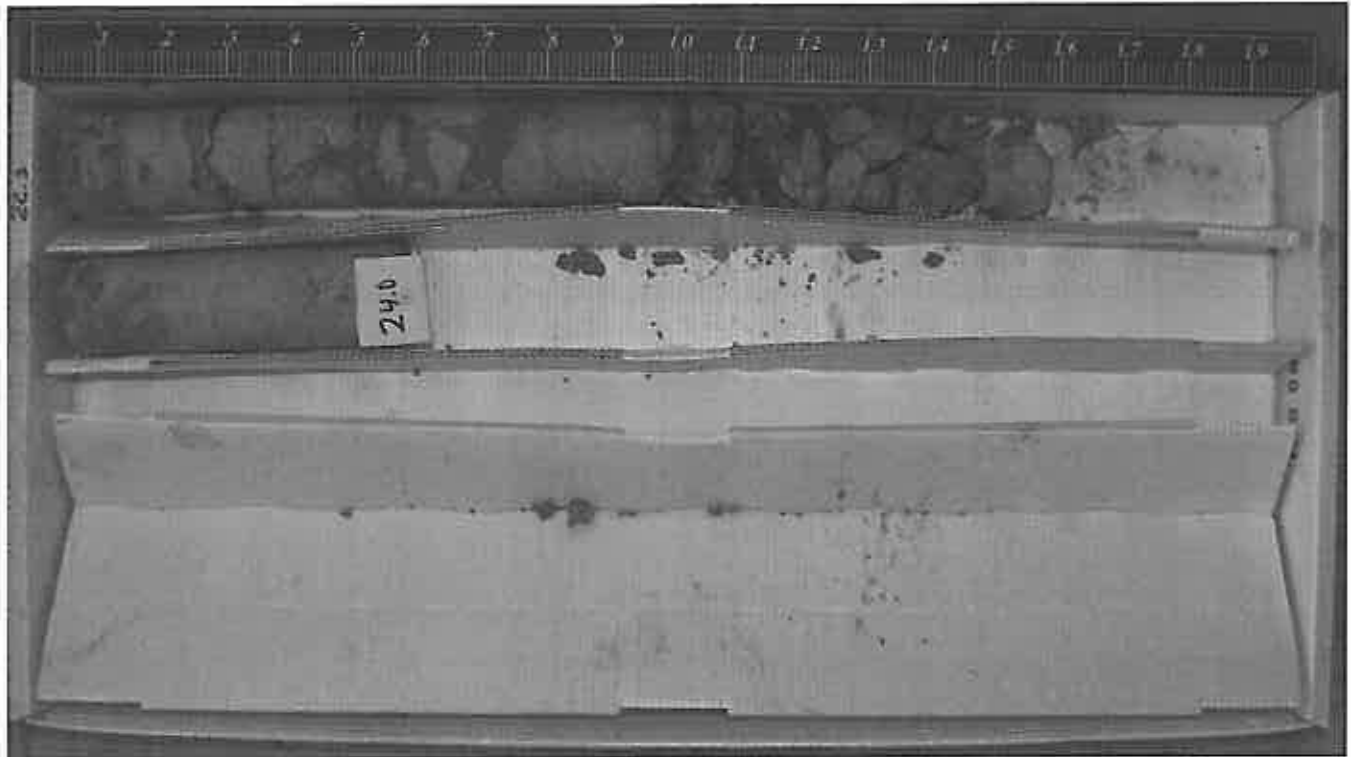

B-3A - Box 3 of 3

CORE PHOTOGRAPHIC RECORD

West Hickman 7
Wet Weather Storage Improvements

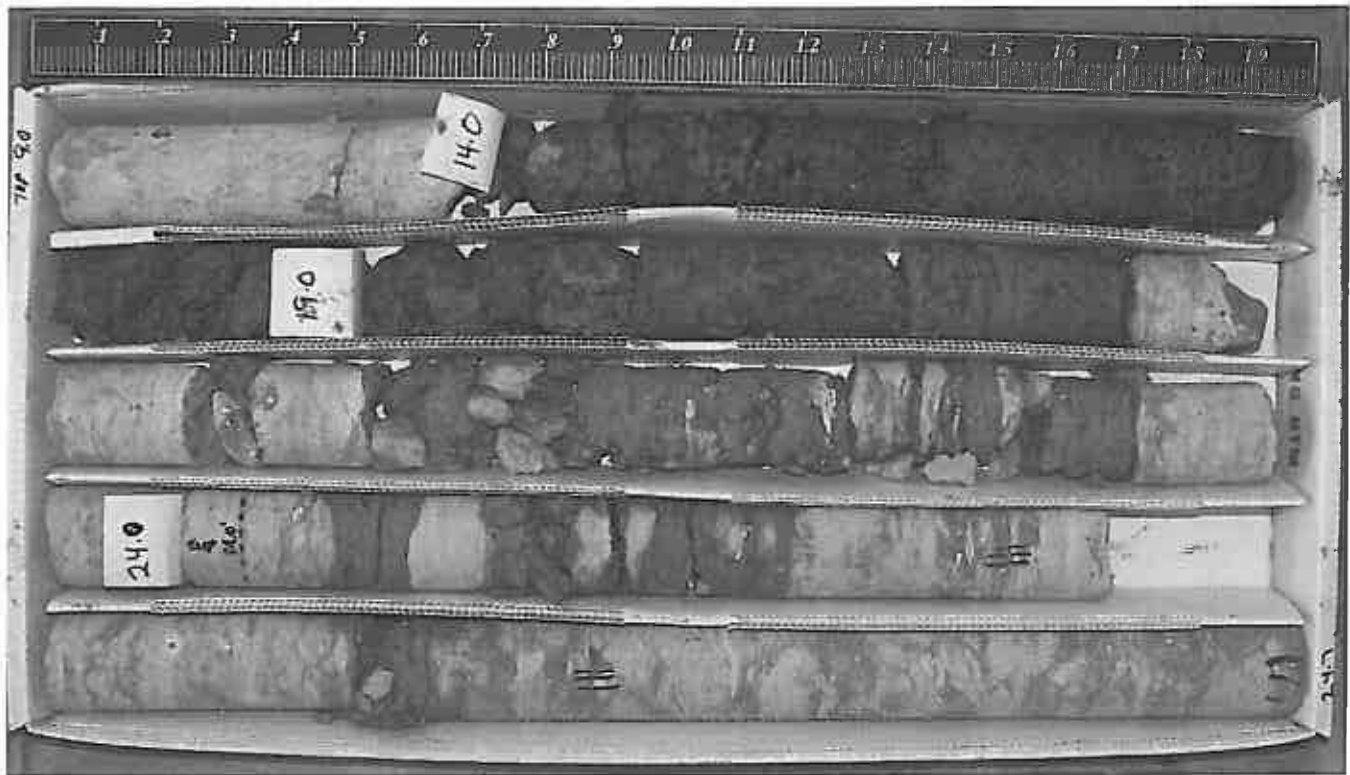

B-5A - Box 1 of 3



B-5A - Box 2 of 3

CORE PHOTOGRAPHIC RECORD

West Hickman 7
Wet Weather Storage Improvements

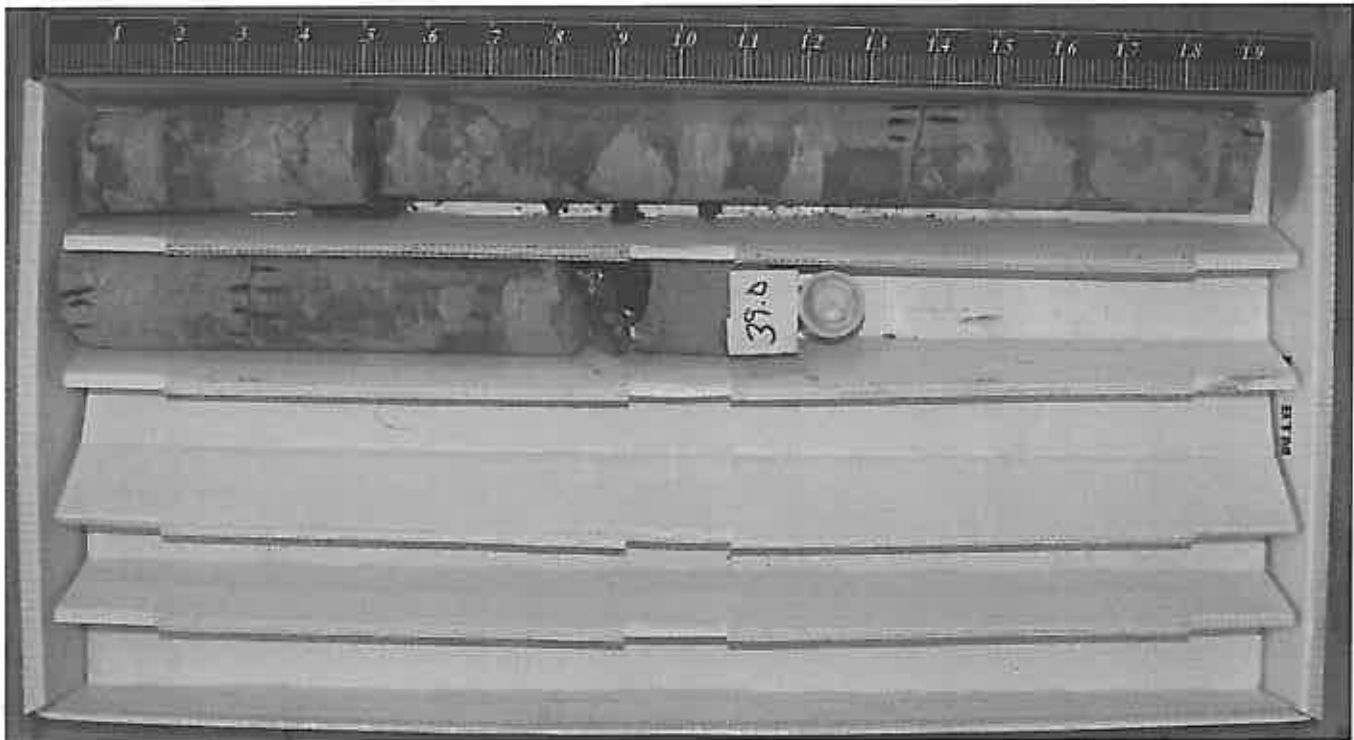

B-5A - Box 3 of 3

Insert above the number and the date of any Addendum issued and received. If none has been issued and received, the word "NONE" should be inserted.

1.02 LEGAL STATUS OF BIDDER

Bidder Midwest Mole Inc.

Date 6-27-2017

*A. A corporation duly organized and doing business under the laws of the State of INDIANA,
for whom Jason D Miller, bearing the
official title of President, whose signature is
affixed to this Bid is duly authorized to execute contracts.

~~*B. A partnership, all the members of which, with addresses are (Designate general partner
as such)~~

~~*C. An individual whose signature is affixed to this Bid (Provide name)~~

* The Bidder shall fill out the appropriate form and strike out the other two.

1.03 BIDDERS AFFIDAVIT

Comes the Affiant, Jason D Miller/President, and after being first duly sworn, states under penalty of perjury as follows:

- A. His/her name is Jason D Miller and he/she is the individual submitting the Bid or is the authorized representative of Midwest Mole Inc., the entity submitting the Bid (hereinafter referred to as "Bidder").
- B. Bidder will pay all taxes and fees, which are owed to the Lexington-Fayette Urban County Government at the time the Bid is submitted, prior to award of the Agreement and will maintain a "current" status in regard to those taxes and fees during the life of the Agreement.
- C. Bidder will obtain a Lexington-Fayette Urban County Government business license, if applicable, prior to award of the Agreement.
- D. Bidder has authorized the Division of Central Purchasing to verify the above-mentioned information with the Division of Revenue and to disclose to the Urban County Council that taxes and/or fees are delinquent or that a business license has not been obtained.
- E. Bidder has not knowingly violated any provision of the campaign finance laws of the Commonwealth of Kentucky within the past five (5) years and the award of an Agreement to the Bidder will not violate any provision of the campaign finance laws of the Commonwealth.
- F. Bidder has not knowingly violated any provision of Chapter 25 of the Lexington-Fayette Urban County Government Code of Ordinances, known as the "Ethics Act."
- G. Bidder acknowledges that "knowingly" for purposes of this Affidavit means, with respect to conduct or to circumstances described by a statute or ordinance defining an offense, that a person is aware or should have been aware that his/her conduct is of that nature or that the circumstance exists.

Further, Affiant sayeth naught.



Affiant Signature

STATE OF INDIANA

COUNTY OF HANCOCK

The foregoing instrument was subscribed, sworn to and acknowledged before me by

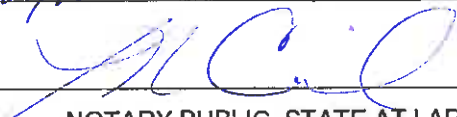
Jason D Miller, President on this the 27rd day of June, 2017.

My Commission expires: 04/26/20 # 634944

NOTARY PUBLIC, STATE AT LARGE

1.04 BID SCHEDULE

The Bidder agrees to perform all the Work described in the Specifications and shown on the Plans for the following proposed lump sum, which shall include the furnishing of all labor, materials, supplies, equipment and/or vehicle usage, services, all items of cost, overhead, taxes (federal, state, local), and profit for the Contractor and any Subcontractor involved, within the time set forth herein. If unit prices are applicable, Bidder must make the extensions and additions showing the total amount of Bid. In all cases of discrepancies or math errors the amount written in for the unit price of an item shall govern.

If a lump sum total price is illegible or is omitted, the bid may be determined nonresponsive.

For a lump sum based bid, the item total is the bid amount the Owner uses for bid comparison.

The Owner's decision on the bid amount is final.

WH7 CONTRACT No.1 NEW CIRCLE ROAD CROSSING - BID SCHEDULE

WH7 CONTRACT No.1 NEW CIRCLE ROAD CROSSING - BID SCHEDULE					
A.	WH7 Cont.No.1 New Circle Road Crossing:				
A1	Base Bid for Construction of the WH7 Contract 1 New Circle Road Crossing per the Contract Documents and Exclusive of the Following Items	1	LS	\$1,321,760.	\$1,321,760.
B.	Allowances:				
B1	Miscellaneous Site Improvements	1	EA	\$200,000	\$200,000
B2	N/a				
B3	N/a				
B4	N/a				
TOTAL BID (Items A thru B)				\$1,521,760.	

TOTAL BID AMOUNT:

One Million Five Hundred Twenty One Thousand Seven Hundred Sixty .

Dollars (\$ 1,521,760.)

Respectfully Submitted,

FIRM: Midwest Mole Inc.

ADDRESS: 6814 W 350 N

CITY/STATE/ZIP: Greenfield, IN 46140

DATE: June 27rd, 2017

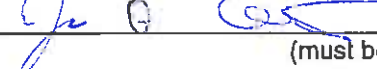
BY:  / Jason D Miller
(must be original signature)

TITLE: President

PHONE: 317-545-1335 FAX: 317-545-1558
(area code, number & extension)

EMAIL ADDRESS: jason@midwestmole.com

OFFICIAL ADDRESS AND PHONE:

Midwest Mole Inc.

6814 W 350 N , Greenfield, IN 46140

Phone: 317-545-1335 (Seal if Bid is by Corporation)

By signing this form you agree to all of the terms and associated forms.

1.05 STATEMENT OF BIDDER'S QUALIFICATIONS

The following statement of the Bidder's qualifications is required to be filled in, executed, and submitted with the Bid:

- A. Name of Bidder: Midwest Mole Inc.
- B. Permanent Place of Business: 6814 W. 350th, Greenfield, IA
- C. When Organized: 02-25-1982 46140
- D. Where Incorporated: Indiana
- E. Financial Condition:

If specifically requested by the Owner, the apparent low Bidder is required to submit its latest three (3) years audited financial statements to the Owner's Division of Central Purchasing within seven (7) calendar days following the Bid opening. Acknowledged

- F. In the event the Agreement is awarded to the undersigned, Performance, Payment, Erosion and Sediment Control, and Warranty bonds will be furnished by:

Continental Casualty Company (Surety)

Signed: Sheree Hsieh (Representative of Surety)
Sheree Hsieh, Attorney-in-Fact

- G. The following is a list of similar projects performed by the Bidder: (Attach separate sheet if necessary).

<u>NAME</u>	<u>LOCATION</u>	<u>CONTRACT SUM</u>
	<u>" See Attached "</u>	

- H. The Bidder has now under contract and bonded the following projects:

<u>NAME</u>	<u>LOCATION</u>	<u>CONTRACT SUM</u>
	<u>" See Attached "</u>	

1870



Midwest Mole, Inc.
Similar Projects Completed

Project Name	Location	Owner	Prime Contractor	Date	Contact Person	Description of Work	Contract Amount
CSD Long Term Control Plan - Deep Plained River Tunnel	Joliet, IL	City of Joliet, IL 150 West Jefferson Street Joliet, IL 60432 Allison Stasibor, PM 815-724-6000	J.J. Henderson & Sons, Inc 4288 Old Orchard Ave Gurnee, IL 60031	Dec 2015	Jeanne Rusdolph, SR PM JJ Henderson 815-244-3323/ 847-244- 9672 jason@j.jhenderson.com	840' of 120" under One Plain River	\$8,866,000.00
Shayer Run Segment "C" Sewer Replacement	Clermont Co, OH	Clermont County Board of Commissioners 4400 Haskell Lane Batavia, OH 45103	Midwest Mole Inc	2010-2011	Lyla Bloom, PE 613-732-8890	9500' of 72" Rock Tunnel in 7 runs for a 42" HOBAS sewer B work shafts and related manholes ranging from 30' to 55' depth	\$14,012,689.00
North Orange, Section 5 Sanitary Trunk Sewer	Delaware Co., OH	Planned Communities	Performance Site Management		Lary Miranda Performance Site Mgmt Rock Tunnel 25' routed by 40' deep work shaft (615) 445-7789	795' of 66" unencased tunnel by TBM	\$1,183,270.31
Fin Branch Pump Station & Force Main	Manassas, VA	Upper Occoquan Sewerage Authority 14631 Compton Rd Centerville, VA 20121 Shakil Ahmed, PE P: 703-596-2200	Fru-Con Construction Corp 7434 Ben Leonard Park Dr Manassas, VA 20111 P. 703-596-6100	Spring 2010	Osama Madkour Fru-Con Construction 703-596-6100	3 turns totaling 950' of 54" casing using Rock TBM for a 36" DIP, 2 work shafts-32' and 18' diameter	\$1,169,715.00
Parkers Run	Steubenville, OH	City of Steubenville 100 N Water St Steubenville, OH 43952 740-283-6000	NWH Constructors 780 N Water St, Suite 430 Milwaukee, WI 53202	2008	Tom Machniski Thomas G. Machniski/Consulting HOBAS Sewer in Rock 800' of 66" Ring Beam & Lagging Tunnel for 42" HOBAS Sewer 7 work shafts 25'-45' deep and one Junction Chamber	1300' OF 84" Ring Beam & Lagging Tunnel for 45" HOBAS Sewer in Rock	\$4,961,892.00
GM Powertrain	Bedford, IN	General Motors 200 N Jackson St Bedford, IN 47421	Appelo/Idelle Construction Company	Winter 2006	Michael A. Delms Appelo/Idelle Const Co (248) 745-5971	610 LF of 60" rib and board tunnel under a large pit for a 46" O.D HOPE Storm Sewer	\$1,372,722.00
Southeastern Interceptor Relief Sewer	Louisville, KY	MSD Louisville 700 W Liberty St Louisville, KY	MAC Construction		Travis Urnau 812-941-7895	540' of 60" Hobas or RCP under N&S RR, Hikes Lane and Newburg Road for a sanitary sewer	\$1,034,167.00
Coeple Creek Replacement Sewer	Cincinnati, OH	MSD of Greater Cincinnati 1800 Great St Cincinnati, OH 45204	Suresis Construction	Winter 2005	Corbin Lewis Suresis Construction (513) 326-6000	521' of 48" steel casing 218' of 54" steel casing 487' of 54" steel casing	\$2,481,481.00
UOSA Primary Curriers	Centerville, VA	Upper Occoquan Sewerage Authority 14631 Compton Rd Centerville, VA 20121	PC Construction formerly Pizzagalli Construction	Winter 2010	Joe Chakos	430' of 60" rock tunneling for a 36" DIP sewer	\$668,271.60
Allen Fork Collection System Phase 1	Cincinnati, OH	Simulation District 1 (SD1) 1045 Eaton Dr Fort Wright, KY 41017	Howell Contractors, Inc	Winter 2006	Paul Brading Howell Contractors, Inc (859) 331-5457	310' of 54" wall steel casing - Rock Tunnel	\$274,601.00
Bilbourn Interceptor Gravity Sewer	Louisville, KY	MSD Louisville 700 W Liberty St Louisville, KY	Flynn Brothers		Flynn Brothers Jason Rice 502-354-9100	362' of 54" x 680' VSSC under a road for a 30" gravity sewer	\$320,880.00



**Midwest Mole,
Jun-17**

Job #	Customer	Original Contract	Percent Complete	Estimated Completion
10034	William Charles	\$ 5,608,713	40.00%	8/31/2017
Multiple	Isolux Corsan	\$ 9,842,700	98.00%	7/1/2017
20218	Bowen Engineering	\$ 468,635	0.00%	8/25/2017
20235	IN American Water	\$ 740,000	97.00%	6/30/2017
20239	FA Wilhelm Construction	\$ 3,385,000	95.00%	6/26/2017
20245	Bowen Engineering	\$ 610,000	70.00%	6/30/2017
20247	Bowen Engineering	\$ 170,078	0.00%	7/17/2017
20251	Bowen Engineering	\$ 264,315	68.00%	6/15/2017
20254	Bowen Engineering	\$ 1,000,000	0.00%	9/8/2017
20257	Town of Pittsboro	\$ 7,500	0.00%	10/8/2017
20258	Calumet Civil	\$ 98,660	35.00%	6/30/2017
20260	IN Dept of Transportation	\$ 337,387	0.00%	9/7/2017
20261	Gradex, Inc.	\$ 125,000	5.00%	9/1/2017
20262	Bowen Engineering	\$ 197,000	20.00%	6/27/2017
20265	IN Dept of Transportation	\$ 889,805	0.00%	11/25/2017
20266	Walsh Construction	\$ 501,024	0.00%	5/1/2018
20267	TSW Utility Solutions	\$ 10,150	100.00%	6/1/2017
30035	Sanitary District No 1	\$ 1,274,000	0.00%	3/16/2018
50032	Rack & Ballauer	\$ 207,205	58.00%	7/14/2017
50033	Building Crafts, Inc.	\$ 513,692	0.00%	9/22/2017
60099	JB James Construction - LA	\$ 1,018,548	87.00%	6/25/2017
60107	Corinthian Contractors - DC	\$ 36,800	0.00%	11/25/2017
60108	HRI, Inc. - PA	\$ 778,860	0.00%	9/1/2017
60109	Milani Construction - MD	\$ 202,354	0.00%	11/25/2017
60110	Willam B. Hopke - MD	\$ 598,444	0.00%	3/15/2018

I. List Key Bidder Personnel who will work on this Project.

<u>NAME</u>	<u>POSITION DESCRIPTION</u>	<u>NO. OF YEARS WITH BIDDER</u>
<u>Jason D Miller</u>	<u>President</u>	<u>20years</u>
<u>Gary Gagliardi</u>	<u>Safety Director</u>	<u>9years</u>
<u>Josh Miller</u>	<u>Superintendent</u>	<u>18years</u>
<u>Darryl Dean</u>	<u>General Superintendent</u>	<u>25years</u>
<u>Jose Ortega</u>	<u>Foreman</u>	<u>20years</u>

J. MWDBE Participation on current bonded projects under contract:

<u>SUBCONTRACTORS (LIST)</u>	<u>PROJECT (SPECIFIC TYPE)</u>	<u>MWDBE</u>	<u>% of WORK</u>
<u>Indiana Sign & Barricade</u>	<u>Jack and Bore</u>	<u>DBE</u>	<u>9%</u>
<u>Crane Environmental</u>	<u>Jack and Bore</u>	<u>DBE</u>	<u>3%</u>
<u>_____</u>	<u>_____</u>	<u>_____</u>	<u>_____</u>
<u>_____</u>	<u>_____</u>	<u>_____</u>	<u>_____</u>
<u>_____</u>	<u>_____</u>	<u>_____</u>	<u>_____</u>
<u>_____</u>	<u>_____</u>	<u>_____</u>	<u>_____</u>
<u>_____</u>	<u>_____</u>	<u>_____</u>	<u>_____</u>

(USE ADDITIONAL SHEETS IF NECESSARY)

K. We acknowledge that, if we are the apparent low Bidder, we may be required to submit to the Owner within seven (7) calendar days following the Bid Opening, a sworn statement regarding all office management and field management personnel. Additionally, if requested by the Owner, we will within seven (7) days following the request submit audited financial statements and loss history for insurance claims for the three (3) most recent years (or a lesser period if stipulated by the Owner) **Acknowledged**

1.06 LIST OF PROPOSED SUBCONTRACTORS

The following list of proposed subcontractors is required by the Owner to be executed, completed and submitted with the Bid Form. All subcontractors are subject to approval of the Lexington-Fayette Urban County Government. Failure to submit this list completely filled out may be cause for rejection of Bid.

<u>BRANCH OF WORK**</u> (List each major item)	<u>SUBCONTRACTOR</u>	<u>MWDBE (yes/no)</u>	<u>% of WORK</u>
1. <u>Seeding</u>	Name: <u>Somthin Bloomin</u> Address: <u>1045 Higbee Mill Rd</u> <u>Lexington, KY</u>	<u>YES</u>	<u>.36%</u>
2. <u>Construction Staking</u>	Name: <u>Allen Engineering</u> Address: <u>2509 Lenlake Ct.</u> <u>Lexington, KY</u>	<u>Yes</u>	<u>.38%</u>
3. <u>Hauling</u>	Name: <u>SLI Contracting</u> Address: <u>1141 Red Mile Rd Suite 201</u> <u>Lexington, KY 40504</u>	<u>Yes</u>	<u>.76%</u>
4. _____	Name: _____ Address: _____ _____	_____	_____
5. _____	Name: _____ Address: _____ _____	_____	_____
6. _____	Name: _____ Address: _____ _____	_____	_____

** Such as: Grading, bituminous paving, concrete, seeding and protection, construction staking, etc.

1.07 AUTHENTICATION OF BID AND STATEMENT OF NON-COLLUSION AND NON-CONFLICT OF INTEREST

I hereby swear (or affirm) under the penalty for false swearing:

- A. That I am the Bidder (if the Bidder is an individual), a partner of the Bidder (if the Bidder is a partnership), or an officer or employee of the Bidding corporation having authority to sign on its behalf (if the Bidder is a corporation);
- B. That the attached Bid has been arrived at by the Bidder independently, and has been submitted without collusion with, and without any agreement, understanding or planned common course of action, with any other contractor, vendor of materials, supplies, equipment or services described in the Advertisement for Bid, designed to limit independent bidding or competition;
- C. That the contents of the Bid or Bids have not been communicated by the Bidder or its employees or agents to any person not an employee or agent of the Bidder or its surety on any bond furnished, with the Bid or Bids, and will not be communicated to any such person, prior to the official opening of the Bid or Bids;
- D. That the Bidder is legally entitled to enter into the contracts with the Lexington-Fayette Urban County Government, and is not in violation of any prohibited conflict of interest;
- E. (Applicable to corporation only) That as a foreign corporation, we are registered with the Secretary of State, Commonwealth of Kentucky, and authorized to do business in the State _____ or, that as a domestic corporation, we are in good standing with the Secretary of State, Commonwealth of Kentucky X . [Check the statement applicable.]
- F. This offer is for ninety (90) calendar days from the date this Bid is opened. In submitting the above, it is expressly agreed that, upon proper acceptance by the Lexington-Fayette Urban County Government of any or all items Bid above, an Agreement shall thereby be created with respect to the items accepted.
- G. That I have fully informed myself regarding the accuracy of the statements made in this statement.
- H. That I certify that Subcontractors have not and will not be awarded to any firm(s) that have been debarred from noncompliance with the Federal Labor Standards, Title VI of the Civil Rights Act of 1964 As Amended, Executive Order 11246 As Amended or any other Federal Law.

Midwest Mole Inc.
Company

6-27-2017
Date

Representative

1.08 STATEMENT OF EXPERIENCE

NAME OF INDIVIDUAL: Jason D Miller

POSITION/TITLE: President

STATEMENT OF EXPERIENCE: See Attached Resume

NAME OF INDIVIDUAL: Gary Gagliardi

POSITION/TITLE: Safety Director

STATEMENT OF EXPERIENCE: See Attached Resume

NAME OF INDIVIDUAL: Josh Miller

POSITION/TITLE: Supperintendent

STATEMENT OF EXPERIENCE: See Attached Resume

NAME OF INDIVIDUAL: Darryl Dean

POSITION/TITLE: General Superintendent

STATEMENT OF EXPERIENCE: See Attached Resume

* Include all officers, office management, Affirmative Action officials, and field management personnel.
Attach separate sheets if necessary.

1.08 STATEMENT OF EXPERIENCE

NAME OF INDIVIDUAL: Joe Butor

POSITION/TITLE: Operations Manager

STATEMENT OF EXPERIENCE: See Attached Resume

NAME OF INDIVIDUAL: Steve Abernathy

POSITION/TITLE: Vice President of Operations/ Project Manager

STATEMENT OF EXPERIENCE: See Attached Resume

NAME OF INDIVIDUAL: Jose Ortega

POSITION/TITLE: Foreman

STATEMENT OF EXPERIENCE: See Attached Resume

NAME OF INDIVIDUAL: N/A

POSITION/TITLE: _____

STATEMENT OF EXPERIENCE: _____

* Include all officers, office management, Affirmative Action officials, and field management personnel. Attach separate sheets if necessary.



Jason Miller
President

Experience Summary:

With over 20 years of experience in the Trenchless Industry, Mr. Miller is an authority in trenchless technology with hands on experience in almost every trenchless method available. He has been involved in numerous aspects of the industry from laborer to management and often serves as consultant on Design/Build projects throughout the nation. His analysis of means and methods and strategic planning has proven to be beneficial to various private owners and municipalities with effective and economical solutions.

Professional Experience:

- **President – 2012 to Present.** Mr. Miller supervises all aspects of operations from bid preparation to review of all completed jobs. He directs and coordinates all field operations and the infrastructure which supports them.
- **Vice President - Midwest Mole, Inc. 2003 to 2012.** Mr. Miller was responsible for the overall operations of the company to include; directing the preparation of estimates, direction of all field activities, review and inspection of proposed jobsites, project coordination and assisting the Project Managers with ongoing projects.
- **Estimator, Midwest Mole, Inc. 1998- 2003.** Mr. Miller was responsible for analyzing blueprints, specifications, proposals, and other documentation to prepare bids for projects. He remained knowledgeable about new technology and innovations in the trenchless industry. Mr. Miller assisted the Project Managers during projects.
- **Laborer, Midwest Mole, Inc., 1995 – 1998.** Mr. Miller gained hands on experience in multiple aspects of the Trenchless Industry in the field. He worked on crews performing hand tunneling, machine tunneling, auger boring, pipe hammering, pipe rehab and more.

Work Experience:

Design/Build and Value Engineering Projects:

- **Oakley Station CSO 551 and 553 Separation Sewer, Cincinnati, OH** Design - Build Storm Sewer Project: 1,933' of 92" rib & board tunnel with 60" Hobas FRP Liner, 300' 72" Jacked RCP HWY Crossing, 120' 72" and 76' 60" RCP Open Cut. 72" Outfall, 6 Storm 72" - 120" manholes, Work pit shoring and excavation, and 40' deep 10' and 11' diameter shafts for tunnel access and manholes, MOT and restoration Project Value \$5.2M
- **Shayler Run Segment "C" Sewer Replacement, OH:** This project consisted of 9500' of 72" rock tunnel in 7 runs for a 42" HOBAS sewer; 8 work shafts and related manholes ranging from 25' to 45' deep. It was originally proposed as 10 runs. Mr. Miller and other key company personnel worked with

6814 W. 350 N. • Greenfield, IN 46140
PHONE 317.545.1335 • FAX 317.545.1558

SAFETY FIRST. QUALITY SECOND. PRODUCTION THIRD.

www.midwestmole.com

• TRENCHLESS SPECIALIST •

Equal Opportunity Employer

the engineer and owner to obtain new easement rights, change the alignment, and reduce the number of bores to 7 which resulted in substantial savings for the owner.

- **Thermal Utility Corridor for New Midfield Terminal, Indianapolis Airport:** After the engineer of this project presented 90% drawings Midwest Mole was contacted to propose cost saving ideas. Mr. Miller along with the GC proposed major design changes that were approved which resulted in a savings of roughly \$20M for the owner. The end result was a project consisting of 2000' of 108" tunnel liner plates for multiple utilities under the existing runways and taxiways and installation of over 3000 CY of grout to fill annular spaces. Midwest Mole won the Project of the Year for Trenchless Technology in 2007 for this project.
- **Delphi Delco Storm Drainage Project, Kokomo, IN:** 800' of 57" OD Steel Casing pipe was installed beneath the assembly plant. There were 2 work shafts. The receiving pits were initially designed under the plant for 2 tunnels. Mr. Miller assisted in designing cost saving methods to retrieve TBM's from under the plant floors without disruption of plant production resulting in substantial cost savings for the owner.
- **Permars Run Relief, OH.** The project consisted of installing 1,300' of 84" beam and lagging tunnel, 770' of 66" beam and lagging tunnel, 170' of 54" casing bore, 450' of 48" open cut. There were 7 work shafts with associate MH's and structures ranging from 20' to 45' depth. A cast in place concrete junction structure was erected around an existing 42" live sewer to tie in new pipeline. Mr. Miller and other key personnel worked to get the alignments changed and give recommendations on pit locations and other key project design issues.
- **Chilled Water Expansion to Eli Lilly, IN:** The project consisted of 400' of 58" steel casing by jacking method, 580' of 54" steel casing by handmine method, three main pits and three receiving pits- up to 30' depth. Mr. Miller was presented with concepts for what needed to be accomplished with this project and worked with the engineer to determine the best methodology including the determination of shaft alignment, location and size, line and grade, and settlement requirements.
- **CSX Barr Yard, Riverdale, IL:** This project was a complete design/build consisting of 6500' of 18" and 1000' of 36" CMP installed via primarily open cut. There were 3 bores and numerous manholes. Mr. Miller and other key personnel worked with CSX Railroad to address drainage issues in their Chicago area rail yard proposing all necessary steps and measures to correct the problems including the type, size, location and depth of pipe needed.

Mr. Miller has also worked as Project Manager on the following notable projects:

- **Latonia Sewer Project, KY.** Mr. Miller was responsible for all aspects of this project. The project consisted of 740' of 84" ring beam and lagging tunnel for a 60" sanitary sewer.
- **North Orange, Section 5 Sanitary Trunk Sewer, OH.** Mr. Miller was responsible for all aspects of this project. The project consisted of 795' of 66" tunnel liner plate by TBM rock tunnel and 25' round by 40' deep work shaft. Tunnel for new 36" sanitary sewer.

Professional Organization:

NUCA National Trenchless Technology Committee

Board Member, Committee Chair NUCA of Indiana.

6814 W. 350 N • Greenfield, IN 46140
PHONE 317.545.1335 • FAX 317.545.1558

SAFETY FIRST. QUALITY SECOND. PRODUCTION THIRD.

www.midwestmole.com

• TRENCHLESS SPECIALIST •

Equal Opportunity Employer



Gary Gagliardi, CFPS
Corporate Safety Director

Experience Summary:

Mr. Gagliardi has 24 years of safety experience in the areas of regulatory compliance, best practices, safety management, and training. A Certified Fire Protection Specialist, he is also an authorized OSHA Outreach Instructor in both Construction and General Industry.

Professional Experience:

- **Corporate Safety Director, Midwest Mole, Inc. 2008 to Present.** Mr. Gagliardi is responsible for directing and implementing all aspects of Midwest Mole's safety program, policies, and procedures. His responsibilities include site inspections to ensure safety compliance, maintaining the substance abuse program, workers compensation, insurance claims, safety committee, and employee training.
- **Vice President, Safety Resources, Inc. 1999-2008.** Mr. Gagliardi was responsible for providing clients multi-level services in all aspects of safety in both the construction and industrial fields. He directed operations, managed business functions, provided supervision, mentored and provided guidance to junior consultants. Mr. Gagliardi developed relationships with many associations including SMACNA, and Indiana Construction Association, serving on the ICA safety counsel for several years.
- **Safety Consultant, Midwest Consulting, 1997-1999.** Mr. Gagliardi conducted site safety supervision, performed audits, site safety inspections, and safety training. He also provided site safety supervision during the construction of a major grain processing plant and an industrial steel processing plant.
- **Safety and Security Manager, Gulfport Job Corps Center, 1992-1997.** Mr. Gagliardi was responsible for the safety and security of 100 staff members and 350 students in a campus environment with vocational classes in numerous construction trades. His duties included developing safety policies and procedures, conducting staff and student safety training.
- **Trainer/Researcher, GE Leadership Center, 1991-1992.** Mr. Gagliardi developed training in management and leadership. Conducted research for new and innovative leadership training material. He also wrote executive summaries.
- **Military Career, United States Air Force, 1971-1991.** Mr. Gagliardi served in the United States Air Force. He held many positions in a variety of disciplines including: Director of Quality Management, Alarm Specialist, Electronic Control Systems, and HVAC Technician. His hands-on experience in skills including electrical, pipefitting and HVAC provides him with an understanding of the worker perspective in their performance of work.

6814 W. 350 N • Greenfield, IN 46140
PHONE 317.545.1335 • FAX 317.545.1558

SAFETY FIRST. QUALITY SECOND. PRODUCTION THIRD.

www.midwestmole.com

• TRENCHLESS SPECIALIST •

Equal Opportunity Employer

Professional Achievements/Associations:

- University of Maryland, Business Administration
- Certified Fire Protection Specialist #1925
- National Fire Protection Association
- Indiana Construction Association Safety Director committee
- Metro Indianapolis Coalition for Construction Safety, Inc (MICCS) Director's committee
- Speaker at the XIX International Occupational Ergonomics & Safety Conference on the topic of tribometry.
- Published research paper titled "*The Integration of the Science of Slips and Falls in a Comprehensive Program to Affect Change.*" in the Journal of the International Society for Occupational Ergonomics & Safety.
- Frequent presenter for BLR (Business and Legal Reports) teleconferences and webinars on various safety topics.
- Published articles in the Trenchless Technology magazine,
- Featured in Los Angeles Times article on safety.
- Midwest Mole Safety Awards:
 - 2014 MICCS Safety Leadership Award
 - 2012 MICCS Safety Leadership Award
 - 2011 UCA Safety Award
 - 2011 ICA Golden Summit Safety Award
 - 2010 NRC/RT&S Contractor Safety Award
 - 2010 ICA Golden Summit Safety Award
 - 2009 MICCS Safety Leadership Award
 - 2008 ICA Golden Summit Safety Award
- OSHA Course #500, Trainer Course in Occupational Safety and Health for Construction
- OSHA Course #501, Trainer Course in Occupational Safety and Health in General Industry
- OSHA Course #225, Principals of Ergonomics
- OSHA Course #210A, Hazardous Materials
- OSHA Course #309A, Electrical Standards
- OSHA Course #204A, Machinery and Machine Guarding Standards
- OSHA Course #510, Occupational Safety and Health Standards in the Construction Industry
- OSHA Course #503, Update for General Industry
- Certified CPR and AED Instructor
- Life Safety Code Seminar
- Fire and Life Safety in Health Care Occupancies
- Radiation Safety
- Advanced Fire Alarm Systems

6814 W. 350 N. • Greenfield, IN 46140
PHONE 317.545.1335 • FAX 317.545.1558

SAFETY FIRST. QUALITY SECOND. PRODUCTION THIRD.
www.midwestmole.com

• TRENCHLESS SPECIALIST •

Local Community Involvement



Joshua Miller
Superintendent

Josh Miller has over 19 years of experience in the trenchless industry with multiple bore and tunnel projects.

SUPERINTENDENT, Midwest Mole Inc, 2005 – Present Job duties include all aspects of the mobilization, execution, and demobilization of projects, planning details of the working procedure by determining the needed labor and supplies and develop a logical approach to completing the work to ensure performance in a safe and productive manner, constantly monitoring the job sites in search of ways to improve methods, equipment, and the quality of the jobs, advise estimating in job costing bids.

FOREMAN/SHOP FOREMAN, Midwest Mole Inc, 1998-2005 Job duties included ensuring that all jobsites had the equipment and supplies they needed in a timely manner to prevent downtime, maintaining company equipment; repairing excavators, cranes, and all the tunneling equipment, design and fabrication for special equipment that may be needed, field fabrication of needed parts/equipment, assisting the superintendents with allocation of manpower and equipment needs on projects, planning, assigning, and directing work flow, maintaining time and production records, training employees, and coordination and evaluation projects.

CURRENT PROJECTS:

- **Duke Energy WR 106 Ph 2, Vigo, Co, IN** 2 runs totaling 1100' of 87.5inch Rib and Lagging for 60" HOBAS under multiple RR; 2 runs totaling 286' of 72" under a levee.
- **Brownsburg Sanitary Sewer Improvement CR900, Brownsburg, IN** 135' of 66" casing
- **Crawfordsville POTW GSC, Crawfordsville, IN** 100' of 60" steel casing for 36" ADS carrier storm sewer

HIGHLIGHT OF PAST PROJECTS:

- **Shayler Run Segment "C" Sewer Replacement, Clermont County, OH. Project Superintendent:** 9,450 linear feet of 72-inch ring beam and lagging tunnel in *solid rock* in segments ranging from 816' to 2,000' for a 42 inch HOBAS sewer line; construction of 8 work shafts and manholes ranging from 37' to 84' in depth. Mr. Miller commissioned a new Robbins RH72 Rock TBM on this project.
- **Permars Run Relief, Steubenville, OH.** The project consisted of 1300' of 84" beam and lagging tunnel, 770' of 66" beam and lagging tunnel in solid rock , 170' of 54" casing bore, 450' of 48" open cut and connecting existing structures. The project had 7 shafts ranging from 30' to 50' in depth.
- **GM Powertrain, Bedford, IN.** 610' of 60" rib and board tunnel in *solid rock* under a large hill for a 48" OD HDPE storm sewer
- **Southeastern Interceptor Relief Sewer, Louisville, KY** 540' of 72" casing in *solid rock* for a 60" sewer under NS RR, Hikes Lane, and Newburg Road for a sanitary sewer.
- **Mounds Creek Culverts, Mound City, IL.** Mr. Miller supervised the installation of two 260' lines of 92" steel casing under a *levee* where the Ohio River meets the Mississippi River
- **New Indianapolis Airport Midfield Terminal Utility Corridor, Indianapolis, IN.** Mr. Miller was responsible for the installation of 2,018' of 102" tunnel liner plate, and EPB tunnel under runways and taxiways for multiple utilities.

6814 W. 350 N. • Greenfield, IN 46140
PHONE 317.545.1335 • FAX 317.545.1558

SAFETY FIRST. QUALITY SECOND. PRODUCTION THIRD.

www.midwestmole.com

• TRENCHLESS SPECIALIST •



Darryl Dean
General
Superintendent

Darryl Dean has over 28 years of experience in the trenchless industry supervising and assisting in the completion of various types of work including pipe hammering, pipe jacking, pipe boring, and conventional tunneling of various lengths and sizes.

Midwest Mole, Inc., 1991– Present. Present job duties include all aspects of the mobilization, execution, and demobilization of projects, planning details of the working procedure by determining the needed labor and supplies and develop a logical approach to completing the work to ensure performance in a safe and productive manner, constantly monitoring the job sites in search of ways to improve methods, equipment, and the quality of the jobs, advise estimating in job costing bids, and acts as a liaison between the company and the general contractor.

CURRENT PROJECTS:

- **Fuller Creek Trunk Sewer Phase C, Rockford, IL** 1,830' (3 x 500' runs & 1 x 330') of 54" casing for a new 24" sewer and grout – *solid rock* work and (1) mixed face ground crossing
- **Riviera Dr Sewer Replacement Project, Bellevue, KY** 350' of 54" HOBAS
- **Riverside Drive CSO Repair, Cincinnati, OH** 240' of 72" HOBAS under RR and road for storm sewer tunnel at 0.75% max grade

HIGHLIGHT OF PAST PROJECTS:

- **Des Plaines River CSO Overflow Tunnel, Joliet, IL** 840' of 120" *solid rock* tunnel under the Des Plaines River for dual 24" HOBAS lines and a 60" HOBAS overflow. 22' diameter shaft in *solid rock* at 60' depth. Tunnel was under an Army Corp regulated area of the Des Plaines river (Corp regulated concrete walls).
- **North Orange, Section 5 Sanitary Trunk Sewer, Delaware County, OH.** Mr. Dean was responsible for all aspects of the field work. The project consisted of 795' of 66" liner plate tunnel by TBM in *solid rock*. Tunnel with 25' round by 40' deep work shaft in *solid rock*.
- **Flat Branch Pump Station and Force Main, Manassas, VA** 3 runs totaling 950' of 54" casing using *solid rock* TBM for 36" DIP; 2 work shafts – 16' and 32' diameter
- **Permars Run Relief, Steubenville, OH.** 1,300' of 84" beam and lagging tunnel, 770' of 66" beam and lagging tunnel in *solid rock*, 170' of 54" casing bore, 450' of 48" open cut and connecting existing structures; 7 shafts ranging from 30'-50' in depth.
- **Cooper Creek Replacement Sewer, Cincinnati, OH** 521' of 48", 218' of 54" and 497' of 54" steel casing, all in *solid rock*
- **UOSA Primary Curifiers, Centreville, VA** 400' of 60" *solid rock* tunnel for a 36" DIP sewer
- **Laflin Street System #4A, Chicago, IL.** Tunneling 992' of 66" RCP and 291' of 60" RCP by jacking method.
- **Latonia Sewer Project, Latonia, KY.** 740' of 84" ring beam and lagging tunnel for a 60" future pipe sanitary sewer.
- **Bliss Run Trunk Sewer Phase 3, Columbus, OH** 362' of 108" ribs and lagging for an 84" HOBAS pipe under Main Street to be used as a storm sewer.
- **Des Plaines Tunnel System, Chicago, IL.** 3,318' of 54" to 96" RCP with the longest runs being 935' of 72" and 972' of 52" using the jacking method for the tunneling.
- **Maple/Berkshire Sanitary Sewer Improvements, Mount Prospect, IL.** 345' of 12" O.D. RCP jack pipe in two (2) runs of 153' and 192' of 38" round shaft at 35' deep, 24" round shaft at 30' deep and two (2) 16' round shafts at 25' deep.

6814 W 350 N. • Greenfield, IN 46140
PHONE 317.545.1335 • FAX 317.545.1558

SAFETY FIRST. QUALITY SECOND. PRODUCTION THIRD.

www.midwestmole.com

• TRENCHLESS SPECIALIST •

Equal Opportunity Employer



Jose Ortega
Foreman

Jose Ortega has over 18 years of experience in the Trenchless Industry. As Lead Foreman on countless tunneling, boring, and grouting projects, Mr. Ortega has led several crews on successful crossings of various sizes utilizing several different methods of installation.

Midwest Mole, Inc., 1999– Present. Jose Ortega started as a laborer gaining valuable hands on experience assisting Management in expediting successful jobs with duties including mobilization, job site preparation, running Auger Boring Machines, Tunnel Boring Machines, haul units, and grouting. His attention to detail and ability to lead crew members led to his eventual position as Lead Foreman in which he is responsible for assisting the Superintendent in expediting successful jobs by planning the work procedure, allocating manpower and equipment, and oversight of laborers and subcontractors to ensure work is being performed in a safe and productive manner. Mr. Ortega is also bilingual.

HIGHLIGHT OF PAST PROJECTS:

- **Des Plaines River CSO Overflow Tunnel, Joliet, IL** 840' of 120" solid *rock* tunnel under the Des Plaines River for dual 24" HOBAS lines and a 60" HOBAS overflow. 22' diameter shaft in *solid rock* at 60' depth. Tunnel was under an Army Corp regulated area of the Des Plaines river (Corp regulated concrete walls).
- **GM Powertrain, Bedford, IN.** Mr. Ortega was responsible for all aspects of the field work. The project consisted of tunneling 610' of 60" rib and board under a large hill for a storm sewer.
- **Cooper Creek Replacement Sewer, Cincinnati, OH** 521' of 48", 218' of 54" and 497' of 54" steel casing, all in *solid rock*
- **Allen Fork Collection System Phase 1, Cincinnati, OH** 313' of 54" steel casing *in rock*
- **Billtown Interceptor Gravity Sewer, Louisville, KY** 382' of 54" *in rock* under a road for a 30" gravity sewer
- **Oakley Station CSO 551 and 553 Separation Sewer, Cincinnati, OH** Design - Build Storm Sewer Project: 1,933' of 92" rib & board tunnel with 60" Hobas FRP Liner, 300' 72" Jacked RCP HWY Crossing, 120' 72" and 76' 60" RCP Open Cut. 72" Outfall, 6 Storm 72" - 120" manholes, Work pit shoring and excavation, and 40' deep 10' and 11' diameter shafts for tunnel access and manholes, MOT and restoration Project Value \$5.2M
- **CEG White River CCS Phase 1, Indianapolis, IN** Project included 168' of 72" RCP jack pipe installed via handmine and 88' of 108" RCP jack pipe installed via excavator shield
- **Cayuga Pedestrian Tunnel, Cayuga, IN.** 206' of 140" ID casing under 5 sets of railroad spurs
- **EPCO, Indianapolis, IN.** 60' of 72" RCP under a fuel line for a storm sewer
- **White River CCS Phase 1, Indianapolis, IN.** 168' of 72" direct jack RCP. 88' of 108" direct jack RCP
- **B-38000-A, Floyd County, IN.** Replaced 278' of 60" RCP
- **IL-25 at I-90 Interchange. Cook, DuPage, and Kane Counties, IL.** 6 crossings totaling 1826' of casing ranging from 15" to 54".
- **New Indianapolis Airport Midfield Terminal Utility Corridor, Indianapolis, IN.** Mr. Ortega supervised the installation of 2,018' of 102" tunnel liner plate, and EPB tunnel under runways and taxiways for multiple utilities.
- **SE Brookside Drive & Covert Ave, Evansville, IN.** 282' of 84" jackable RCP under US 41 for a gravity sewer.
- **VDOT – Route 7 Westbound Truck Climing Lane, Leesburg, VA.** 205' of 36"; 235' of 48"; 275' of 54"; 130' of 66" RCP pipe jacking; 180' of 60-66" RCP. Pipe jacking total of 10 crossing
- **Square 737 and 739 Sewer Relocation, Washington DC.** Project included 918' of 48" Hobas jack pipe in 4 runs at 40 - 50 foot depth for sanitary sewer relocation; 2 rib and board work shafts 26' diameter; 3 rib and board receiving shafts 32' diameter, 3 CIP and 2 Precast manholes and associated temporary passive sewer bypass.

6814 W. 350 N. • Greenfield, IN 46140
PHONE 317.545.1335 • FAX 317.545.1558

SAFETY FIRST. QUALITY SECOND. PRODUCTION THIRD.

www.midwestmole.com

• TRENCHLESS SPECIALIST •



Stephen D. Abernathy
Vice President of Operations / Project Manager

Experience Summary:

Mr. Abernathy has over 25 years experience in Heavy Civil Construction and Municipal Infrastructure. Working as a general contractor and a subcontractor, he has directed numerous underground utility, roadway, bridge, site and other projects in the capacity of a project manager and as a company executive. Currently he oversees and coordinates major project operations and assists the President and Vice President of the company in making crucial decisions to enhance our services to our customers.

Professional Experience:

- **Project Manager, Vice President - Midwest Mole, Inc. 2009 to Present.** Mr. Abernathy is responsible for overall management and the construction field operations for major company projects including: Direction of construction operations, Area operations management, and Project management.
- **General Manager – Bray-Arnspurger Excavating, Inc. 2005-2008.** The GM of a \$20M+ commercial excavation, utility and site development contractor that employed approximately 95 people. Mr. Abernathy managed and oversaw all company operations including estimating, project management, field operations, personnel, safety and equipment management with profit and loss responsibility.
- **Vice President – Sunesis Construction Co. 1992 to 2005.** Started his position as project manager to manage roadway, underground utility, bridge and other construction projects as company grew from revenue \$2mill to \$7mill per year. In 1995, he was promoted to Vice President. Mr. Abernathy led the diversified public works and infrastructure business in growth from \$7M to \$34M+ in annual revenue and from 40 to 150 employees performing work in three states. Directed field operations and project management staff to fulfill the company's contractual obligations. Implemented and updated organizational structure and systems to facilitate profitable growth and increase operational efficiency.

Education:

Purdue University, W. Lafayette, IN
Bachelor of Science – Mechanical Engineering
Graduate 1988

Professional Organizations:

American Society of Civil Engineers; ASCE
Society for Mining, Metallurgy, and Exploration; SME

6814 W. 350 N. • Greenfield, IN 46140
PHONE 317.545.1335 • FAX 317.545.1558

SAFETY FIRST. QUALITY SECOND. PRODUCTION THIRD.

www.midwestmole.com

• TRENCHLESS SPECIALIST •

Stephen D. Abernathy
Vice President of Operations / Project Manager

Selected Project Experience:

- **Des Plaines River CSO Overflow Tunnel, Joliet, IL** 840' of 120" rock tunnel under the Des Plaines River for dual 24" HOBAS lines and a 60" HOBAS overflow. 22' diameter shaft at 60' depth.
- **Shayler Run Segment "C" Sewer Replacement, Clermont Co, OH.** The project consisted of approximately 9500 LF of 72" Rock Tunnel in 7 runs for a 42" HOBAS sewer, 8 work shafts and related manholes ranging from 30' to 55' depths. Project Value \$15M
- **Flat Branch Pump Station & Force Main, Manassas, VA** 3 runs totaling 909' of 54" casing using Rock TBM for a 36" HOBAS sanitary sewer; 2 work shafts-32' and 16' diameter Project Value \$1.1M
- **Permars Run Relief, Steubenville, OH.** 1,300' of 84" beam and lagging tunnel, 770' of 66" beam and lagging tunnel in *solid rock*, 170' of 54" casing bore, 450' of 48" open cut and connecting existing structures; 7 shafts ranging from 30'-50' in depth
- **Southeastern Interceptor Relief Sewer, Louisville, KY** 540' of 60" under NS RR, Hikes Lane, and Newburg Road for a sanitary sewer.
- **Cooper Creek Replacement Sewer, Cincinnati, OH** 521' of 48", 218' of 54" and 497' of 54" steel casing, all in *solid rock*
- **UOSA Primary Curifiers, Centreville, VA** 400' of 60" *solid rock* tunnel for a 36" DIP sewer
- **IL Tollway I-13-4104, Cook, Dupage and Kane Co, IL** The project consisted of 227' of 24", 649' of 30", 609' of 72", 95' of 48", 57' of 66" pipe hammered under highway.
- **Shadow Wood WWTP Decommission, Louisville, KY** 2 runs totaling 485' of 36"-44" walled steel casing under Harrods Creek for a 15" PVC Sewer
- **Queen City Ave Sewer Separation Phase 1, Cincinnati, OH** 90' of 84"ID/87"OD fiberglass jacking pipe under utilities for a sewer
- **ODOT 236, Toledo, OH** 2,143' of 57" ID/60"OD Hobas Slipliner pipe inside an existing deteriorated 66" RCP
- **Building 160 at the Yards, Washington DC** (3) runs of 606' of 69" Hobas Slipliner inside existing 6'-3" sewer; install one manhole; bulkhead the ends of the liner, and fill the annular space with lightweight cellular grout.
- **US Coast Guard Headquarters, Washington DC** 2,539' of 90" Slipline pipe inside an existing 102" x 114" brick and concrete sanitary sewer. Both Straight and curved sections were lined
- **ENRF Enhanced Nitrogen Removal Facility Phase 2, Washington DC** 238' of 144"ID/170" OD RCP Jack Pipe under existing tanks and roads for gravity sewer.
- **M Street Diversion Sewer, Washington DC** Rehab East Side Interceptor: 1,121' of existing 75" concrete and brick sliplined with 60" and 63" Flow-tite for a gravity sewer.
- **South Forced Lower Capacity Improvements, Baton Rouge, LA** 6 runs totaling 1,939' of 24" Hobas jack pipe for a sanitary sewer, 7 work shafts, 5 manholes set via Vermeer Axis System (Pilot tube Microtunnel)
- **Square 737 and 739 Sewer Relocation, Washington DC.** The project consisted of 918' of 48" HOBAS jack pipe in 4 runs at 40-50 foot depth for a sanitary sewer relocation. 2 rib and board shafts 26 feet in diameter and 3 rib and board receiving shafts 32 feet in diameter. 3 CIP and 2 Precast manholes and associated temporary passive sewer bypass. Value \$4.2M
- **Oakley Station CSO 551 and 553 Separation Sewer, Cincinnati, OH** Design - Build Storm Sewer Project: 1,933' of 92" rib & board tunnel with 60" Hobas FRP Liner, 300' 72" Jacked RCP HWY Crossing, 120' of 72" and 76' of 60" RCP Open Cut. 72" Outfall structure, 6 Storm manholes 72" - 120" , Work pit shoring and excavation, 10' and 11' diameter shafts 40' deep for tunnel access and manholes, MOT and restoration Project Value \$5.2M
- **Wood River CORE Project, Roxanna, IL.** 900' of 30" casing in three runs via GBM; installation of 20" and 30" steel petroleum line with wax fill; 2 work pits 25 feet in depth-25x40 and 12x40 Project Value \$3M

6814 W. 350 N. • Greenfield, IN 46140
PHONE 317.545.1335 • FAX 317.545.1558

SAFETY FIRST. QUALITY SECOND. PRODUCTION THIRD.

www.midwestmole.com

• TRENCHLESS SPECIALIST •



Joseph D. Butor, P.E.
Operations Manager

Experience Summary:

Mr. Butor has been involved with various types of construction projects in several parts of the country. He has over 12 years of experience in the construction industry, including bridge construction, office buildings, parking structures, and tunneling. Mr. Butor has experience in the role of Subcontractor as well as General Contractor. He has had a wide range of responsibilities throughout his career, functioning as Field Engineer, Estimator, Project Manager, and Field Operations Manager.

Professional Experience:

- **Field Operations Manager, Midwest Mole, Inc., June 2010-Present.** Mr. Butor is responsible for the management of all field operations. Responsibilities include contract negotiation and management, scheduling overall company operations, resource allocation, dispute resolution, overall cost control, equipment selection, oversight of daily operations as well as technical/engineering support for project management.
- **Project Manager/Estimator, Midwest Mole, Inc., February 2005-June 2010.** Mr. Butor's responsibilities include: Reviewing Plans, Specifications and Geotechnical Information, determining method of installation, preparing estimate, coordination with Owner, Engineer, and General Contractor, material procurement, equipment selection, preparing submittals, managing schedule and budget, union negotiations, document control, and contract negotiations on projects up to \$8.1M.
- **Field Engineer, Charles Pankow Builders, Los Angeles, CA., June 2004 –December 2004.** Mr. Butor was the Field Engineer on the LA County Department of Public Social Services Project. This was a 4-story office building with adjacent 500 vehicle parking structure. The Project value was approximately \$35M. Mr. Butor was responsible for: Submittal Review, Generating RFI's, Detailing Shop Drawings, Coordination with Subcontractors and County Inspectors, ensuring all work was in compliance with Plans, Specifications, and Building Codes, material takeoffs and procurement.
- **Intern, Flatiron Structures Company, May 2001-August 2003.** Mr. Butor held three internships at Flatiron Structures Company as part of his Bachelor of Science in Construction Engineering and Management during summer months. As part of his internship Mr. Butor was involved in the following projects:
 - **Logan Terminal Area Runways**
Scope: 6000 L.F. of post-tensioned cast-in-place box girder viaduct
Valuation: \$87M
 - **US 64 Knightdale Bypass**
Scope: 11 miles of six-lane highway and 23 bridge structures
Valuation: \$131M

6814 W. 350 N. • Greenfield, IN 46140
PHONE 317.545.1335 • FAX 317.545.1558

SAFETY FIRST. QUALITY SECOND. PRODUCTION THIRD.

www.midwestmole.com

• TRENCHLESS SPECIALIST •

Work Experience:

- **Shively Interceptor Project, Louisville, KY**

Valuation: \$4.4 Million

Scope: Approximately 10,000 LF of Pilot Tube Microtunnel sizes ranging from 15" to 20" VCP.

- **Shayler Run Segment "C" Sewer Replacement, Clermont Co, OH**

Valuation: \$15 Million

Scope: 9500 LF of 72" Rock Tunnel in 7 runs for a 42" HOBAS sewer, 8 work shafts and related manholes ranging from 25' to 5' depths.

- **Lemay WWTP Wet Weather Expansion, St. Louis, MO**

Valuation: \$5.1 Million

Scope: Install 560 LF of 16' diameter circular and horseshoe steel liner plate tunnel utilizing roadheader for excavation. Thread 132" PCCP effluent sewer inside tunnel and backfill with lightweight cellular grout.

- **CEP-IMC Utility Connector, Indianapolis, IN**

Valuation: \$8.1 Million

Scope: Install 2,000 LF of 8.5' diameter steel liner plate tunnel utilizing Earth Pressure Balance Tunnel Boring Machine. Backfilled tunnel with 3,000 cubic yards of lightweight cellular grout.

- **South Stormwater Collection Station Bypass Sewer, Bedford, IN**

Valuation: \$1.3 Million

Scope: Install 610 LF of 5.2' diameter Steel Ribs and Wood Lagging utilizing a Robbins Rockhead Double Shield TBM. Tunnel was through limestone with UCS of 25,000 psi and impacted material.

Education:

Bachelor of Science in Construction Engineering and Management

Purdue University, West Lafayette, IN

Graduated May 2004

Professional Organizations:

Member of American Society of Civil Engineers

Member of Deep Foundation Institute

Member of Society of Mining, Metallurgy, and Exploration

NASTT

MSTT (former President)

Licensed Professional Engineer State of Indiana

6814 W. 350 N. • Greenfield, IN 46140
PHONE 317.545.1335 • FAX 317.545.1558

SAFETY FIRST. QUALITY SECOND. PRODUCTION THIRD.

www.midwestmole.com

• TRENCHLESS SPECIALIST •

1.09 EQUAL OPPORTUNITY AGREEMENT

The Law

- * Title VII of the Civil Rights Act of 1964 (amended 1972) states that it is unlawful for an employer to discriminate in employment because of race, color, religion, sex, age (40-70 years) or national origin.
- * Executive Order No. 11246 on Nondiscrimination under Federal contract prohibits employment discrimination by contractor and subcontractor doing business with the Federal Government or recipients of Federal funds. This order was later amended by Executive Order No. 11375 to prohibit discrimination on the basis of sex.
- * Section 503 of the Rehabilitation Act of 1973 States:

The Contractor will not discriminate against any employee or applicant for employment because of physical or mental handicap.

- * Section 2012 of the Vietnam Era Veterans Readjustment Act of 1973 requires Affirmative Action on behalf of disabled veterans and veterans of the Vietnam Era by contractors having Federal Contracts.
- * Section 206 (A) of Executive Order 12086, Consolidation of Contract Compliance Functions for Equal Employment Opportunity, states:

The Secretary of Labor may investigate the employment practices of any Government contractor or sub-contractor to determine whether or not the contractual provisions specified in Section 202 of this order have been violated.

The Lexington-Fayette Urban County Government practices Equal Opportunity in recruiting, hiring and promoting. It is the Government's intent to affirmatively provide employment opportunities for those individuals who have previously not been allowed to enter into the mainstream of society. Because of its importance to the local Government, this policy carries the full endorsement of the Mayor, Commissioners, Directors, and all supervisory personnel. In following this commitment to Equal Employment Opportunity and because the Government is the benefactor of the Federal funds, it is both against the Urban County Government policy and illegal for the Government to let contracts to companies which knowingly or unknowingly practice discrimination in their employment practices. Violation of the above mentioned ordinances may cause an Agreement to be canceled and the contractor may be declared ineligible for future consideration.

Please sign this statement in the appropriate space acknowledging that you have read and understand the provisions contained herein. Return this document as part of your application packet.

Bidders

I/We agree to comply with the Civil Rights Laws listed above that govern employment rights of minorities, women, Vietnam veterans, handicapped, and aged persons.

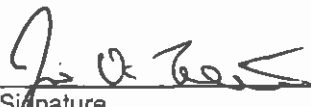

Signature

Midwest Mole Inc.

Name of Business

The Entity (regardless of whether construction Contractor, non-construction Contractor or supplier) agrees to provide equal opportunity in employment for all qualified persons, to prohibit discrimination in employment because of race, color, creed, national origin, sex or age, and to promote equal employment through a positive, continuing program from itself and each of its sub-contracting agents. This program of equal employment opportunity shall apply to every aspect of its employment policies and practices.

The Kentucky Equal Employment Opportunity Act of 1978 (KRS 45.560-45.640) requires that any county, city, town, school district, water district, hospital district, or other political subdivision of the state shall include in directly or indirectly publicly funded contracts for supplies, materials, services, or equipment hereinafter entered into the following provisions:

During the performance of this contract, the contractor agrees as follows:

- (1) The contractor will not discriminate against any employee or applicant for employment because of race, color, religion, sex, age or national origin;*
- (2) The contractor will state in all solicitations or advertisements for employees placed by or on behalf of the contractors that all qualified applicants will receive consideration for employment without regard to race, color, religion, sex, age or national origin;*
- (3) The contractor will post notices in conspicuous places, available to employees and applicants for employment, setting forth the provisions of the non-discrimination clauses required by this section; and*
- (4) The contractor will send a notice to each labor union or representative of workers with which he has a collective bargaining agreement or other contract or understanding advising the labor union or workers' representative of the contractor's commitments under the nondiscrimination clauses.*

The Act further provides:

KRS 45.610. Hiring minorities - Information required

- (1) For the length of the contract, each contractor shall hire minorities from other sources within the drawing area, should the union with which he has collective bargaining agreements be unwilling to supply sufficient minorities to satisfy the agreed upon goals and timetable.*
- (2) Each contractor shall, for the length of the contract, furnish such information as required by KRS 45.560 to KRS 45.640 and by such rules, regulations and orders issued pursuant thereto and will permit access to all books and records pertaining to his employment practices and work sites by the contracting agency and the department for purposes of investigation to ascertain compliance with KRS 45.560 to 45.640 and such rules, regulations and orders issued pursuant thereto.*

KRS 45.620. Action against contractor - Hiring of minority contractor or subcontractor

- (1) If any contractor is found by the department to have engaged in an unlawful practice under this chapter during the course of performing under a contract or subcontract covered under KRS 45.560 to 45.640, the department shall so certify to the contracting agency and such certification shall be binding upon the contracting agency unless it is reversed in the course of judicial review.*
- (2) If the contractor is found to have committed an unlawful practice under KRS 45.560 to 45.640, the contracting agency may cancel or terminate the contract, conditioned upon a program for future compliance approved by the contracting agency and the department. The contracting agency may declare such a contractor ineligible to bid on further contracts with that agency until such time as the contractor complies in full with the requirements of KRS 45.560 to 45.640.*
- (3) The equal employment provisions of KRS 45.560 to 45.640 may be met in part by a contractor by subcontracting to a minority contractor or subcontractor. For the provisions of KRS 45.560 to 45.640, a minority contractor or subcontractor shall mean a business that is owned and controlled by one or more persons disadvantaged by racial or ethnic circumstances.*

KRS 45.630 Termination of existing employee not required, when

Any provision of KRS 45.560 to 45.640 notwithstanding, no contractor shall be required to terminate an existing employee upon proof that that employee was employed prior to the date of the contract.

KRS 45.640 Minimum skills

Nothing in KRS 45.560 to 45.640 shall require a contractor to hire anyone who fails to demonstrate the minimum skills required to perform a particular job.

In the case of an Agreement exceeding \$250,000, the Contractor will be required within seven (7) days following the Bid Opening to furnish evidence that its work-force in Kentucky is representative of the available work-force in the area from which it draws employees, or to supply an Affirmative Action plan which will achieve such representation during the life of the Contract.



COMMONWEALTH OF KENTUCKY
TRANSPORTATION CABINET

Frankfort, Kentucky 40622
www.transportation.ky.gov/

Matthew G. Bevin
Governor

Greg Thomas
Secretary

October 27, 2016

Ms. Danette Wilder and
Ms. Gwendolyn Wilder
SLI Contracting
1141 Red Mile Road
Suite 201
Lexington, Kentucky 40504

Subject: DBE Certification for
SLI Contracting

Ladies:

SLI Contracting is certified as a Disadvantaged Business Enterprise (DBE) as outlined in 49 C.F.R. Part 26. Once a firm is certified it shall remain certified until and unless it is removed from the program for cause. As a result, we no longer issue certificates as proof of DBE Certification. We will continue to issue certification letters to firms, and the DBE firm should retain the letter as proof of DBE Certification. In addition, the DBE Directory confirms the continued certification status of a firm including the business activities or services it renders.

If companies wish to verify your firm's status with us directly, please do not hesitate to have them contact the Office for Civil Rights and Small Business Development at 502-564-3601.

Sincerely,

A handwritten signature in cursive script, appearing to read "Jamie Clifton".

Jamie Clifton
Program Investigative Officer
Small Business Development Branch



An Equal Opportunity Employer M/F/D



QUOTE

SLI Contracting
1141 Red Mile Rd., Suite 201, Lexington, KY 40504
Ph: 859-977-6640 Fax: 859-977-6644
info@slicontracting.com

DATE: JUNE 26, 2017
QUOTE # 20170626-1

EXPIRATION DATE: JULY
26, 2017

TO

Midwest Mole Inc.
6814 W 350 N
Greenfield, IN 46140
317-545-1335
Customer ID: MWMI

SALESPERSON	JOB	PAYMENT TERMS	DUE DATE	
G. WILDER	Hauling- West Hickman	Net 15 day		
QTY	DESCRIPTION	UNIT	UNIT PRICE	LINE TOTAL
	Hauling Services (dirt, gravel, rock, etc)			
	Haul Rate (dirt, gravel, etc.)	HR	90.00	
	Haul Rate (shot rock, slabs, etc.)	HR	125.00	

SUBTOTAL

TOTAL

Acceptance of Proposal: The above prices, specification and conditions above are satisfactory and hereby accepted as a contract for work. The undersigned hereby agrees that SLI Contracting LLC is authorized to do the work as specified and agrees to payment terms above.

Thank you for your business!

6/26/17

Quotation prepared by: _____

To accept this quotation, sign here and return: _____

**Disadvantaged Business Enterprise (DBE) Program
 DBE Subcontractor Performance Form**

I certify under penalty of perjury that the forgoing statements are true and correct. Signing this form does not signify a commitment to utilize the subcontractors above. I am aware of that in the event of a replacement of a subcontractor, I will adhere to the replacement requirements set forth in 40 CFR Part 33 Section 33.302 (c).

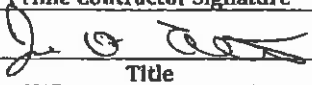
Prime Contractor Signature 	Print Name Jason D Miller
Title President	Date 6/23/2017

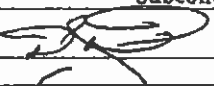
Subcontractor Signature 	Print Name Danette J. Wilder
Title President	Date 6/26/17

The public reporting and recordkeeping burden for this collection of information is estimated to average three (3) hours per response. Send comments on the Agency's need for this information, the accuracy of the provided burden estimates, and any suggested methods for minimizing respondent burden, including through the use of automated collection techniques to the Director, Collection Strategies Division, U.S. Environmental Protection Agency (2822T), 1200 Pennsylvania Ave., NW, Washington, D.C. 20460. Include the OMB control number in any correspondence. Do not send the completed form to this address.

EPA FORM 6100-3 (DBE Subcontractor Performance Form)

1.11 MWDBE SUBCONTRACTOR PERFORMANCE FORM



OMB Control No: 2090-0030
 Approved: 8/13/2013
 Approval Expires: 8/31/2015

**Disadvantaged Business Enterprise (DBE) Program
 DBE Subcontractor Performance Form**

This form is intended to capture the DBE¹ subcontractor's² description of work to be performed and the price of the work submitted to the prime contractor. An EPA Financial Assistance Agreement Recipient must require its prime contractor to have its DBE subcontractors complete this form and include all completed forms in the prime contractor's bid or proposal package.

Subcontractor Name SLI Contracting, LLC		Project Name West Hickman 7(WE7) Wet Weather Storage Facilities Improvements- Contract No. 1 New Circle Road Crossing.	
Bid/ Proposal No. 80-2017	Assistance Agreement ID No. (if known)	Point of Contact Danette Wilder	
Address 1141 Red Mile Rd., Suite 201, Lexington, KY 40504			
Telephone No. 859-977-6640		Email Address wilderdj@sliccontracting.com	
Prime Contractor Name Midwest Mole Inc.		Issuing/Funding Entity:	

Contract Item Number	Description of Work Submitted to the Prime Contractor Involving Construction, Services, Equipment or Supplies	Price of Work Submitted to the Prime Contractor
	Hauling (dirt, gravel etc.)	90.00 hr
	Hauling (shot rock, slabs, etc.)	125.00 hr
DBE Certified By: <input checked="" type="checkbox"/> DOT <input type="checkbox"/> SBA <input type="checkbox"/> Other: _____		Meets/ exceeds EPA certification standards? <input type="checkbox"/> YES <input type="checkbox"/> NO <input type="checkbox"/> Unknown

¹ A DBE is a Disadvantaged, Minority, or Woman Business Enterprise that has been certified by an entity from which EPA accepts certifications as described in 40 CFR 33.204-33.205 or certified by EPA. EPA accepts certifications from entities that meet or exceed EPA certification standards as described in 40 CFR 33.202.

² Subcontractor is defined as a company, firm, joint venture, or individual who enters into an agreement with a contractor to provide services pursuant to an EPA award of financial assistance.

EPA FORM 6100-3 (DBE Subcontractor Performance Form)



COMMONWEALTH OF KENTUCKY

Matthew G. Bevin
Governor

April 20, 2016

Lilli Allen, President
ALLEN ENGINEERING, INC.
2509 Lenlake Court
Lexington, KY 40513

Dear Mrs. Allen:

The Kentucky Transportation Cabinet's DBE Certification Committee has determined that ALLEN ENGINEERING, INC. continues to meet the eligibility requirements of a woman-owned Disadvantaged Business Enterprise (DBE) and remains program-eligible pursuant to 49 C.F.R., Part 26. Along with your DBE continuation, your Small Business Enterprise (SBE) certification has been reciprocally renewed.

ALLEN ENGINEERING, INC. is DBE/SBE certified to perform the below NAICS codes, which include the following items of work:

NAICS code(s) for which DBE/SBE status is recognized: 237310, 237990, 238110

Items of Work: construction staking, preparing development plans, small civil engineering design projects, erosion control projects, storm, sanitary sewer, highway, street and bridge construction, civil engineering construction, and poured and structure concrete

Absent a finding of regulatory non-compliance, a change in the majority ownership and/or control, or a successful third party challenge, **this certification will be eligible for review on April 30, 2019.**

In accordance with 49 C.F.R. §26.83(j), this firm will be required to submit an affidavit annually to determine whether your firm continues to meet the standards as set forth in 49 C.F.R., Part 26.

Sincerely,

Tony Youssefi
DBE Branch Manager
Small Business Development Branch

mrt/TY



An Equal Opportunity Employer M/F/D

Invitation to Bid

Project Name: West Hickman 7(WH7)Wet Weather Storage Facilities-Contract #1 New Circle Road Crossing

Project Location: Lexington, KY

Bid Date: 6/23/2017 Invitation To Bid Sent Via: Email

Project Description: 60 inch pipe installed by trenchless technology .

Bids/Quotes Due: 6/21/2017

Are you a certified MBE/WBE: YES or NO

Plans are available for review at:
<https://midwestmole.box.com/s/ur7td5c7c34hl8dubsa059816v7g0q4>

For further information or coordination regarding your proposal please contact:
Ryan Barkdull 317-545-1335 ext 134 or email plandesk@midwestmole.com

Scopes Requested For Bid

- Erosion Control
- Shoring
- Temp Access Roads
- Suppliers
- Traffic Control
- Landscape/Restoration
- Your Scope Construction Staking

Bid Fax Response

Bidding (Check): YES NO

Company Name: Allen Engineering Contact Person: Lilli Allen

Phone: 859-229-7362 Fax: 859-223-1948

Email: lmallen2509@yahoo.com Scope(s) Bidding: Construction Staking

1.10 MWDBE SUBCONTRACTOR PARTICIPATION FORM



CMB Control No: 2090-0030
 Approved: 8/13/2013
 Approval Expires: 8/31/2015

Disadvantaged Business Enterprise (DBE) Program
 DBE Subcontractor Participation Form

An EPA Financial Assistance Agreement Recipient must require its prime contractors to provide this form to its DBE subcontractors. This form gives a DBE¹ subcontractor² the opportunity to describe work received and/or report any concerns regarding the EPA-funded project (e.g., in areas such as termination by prime contractor, late payments, etc.). The DBE subcontractor can, as an option, complete and submit this form to the EPA DBE Coordinator at any time during the project period of performance.

Subcontractor Name Allen Engineering Inc		Project Name West Hickman 20WH7 Wet Weather Storage Facilities Improvements- Contract No 1 New Circle Road Crossing	
BID/ Proposal No. 80-2017	Assistance Agreement ID No. (if known)	Point of Contact Lilli Allen	
Address 2509 Lenlake Ct Lexington Ky 40513			
Telephone No. 859-229-7362		Email Address lallen2509@yahoo.com	
Prime Contractor Name Midwest Mole Inc.		Issuing/Funding Entity:	

Contract Item Number	Description of Work Received from the Prime Contractor Involving Construction, Services, Equipment or Supplies	Amount Received by Prime Contractor
	Construction Staking Includes all labor, supplies, and insurance, but not bonding	5000⁰⁰ lump sum

¹ A DBE is a Disadvantaged, Minority, or Woman Business Enterprise that has been certified by an entity from which EPA accepts certifications as described in 40 CFR 33.204-33.205 or certified by EPA. EPA accepts certifications from entities that meet or exceed EPA certification standards as described in 40 CFR 33.202.

² Subcontractor is defined as a company, firm, joint venture, or individual who enters into an agreement with a contractor to provide services pursuant to an EPA award of financial assistance.

EPA FORM 6100-2 (DBE Subcontractor Participation Form)

1.11 MWDBE SUBCONTRACTOR PERFORMANCE FORM



OMB Control No: 2090-0030
 Approved: 8/13/2013
 Approval Expires 8/31/2015

Disadvantaged Business Enterprise (DBE) Program
 DBE Subcontractor Performance Form

This form is intended to capture the DBE¹ subcontractor's² description of work to be performed and the price of the work submitted to the prime contractor. An EPA Financial Assistance Agreement Recipient must require its prime contractor to have its DBE subcontractors complete this form and include all completed forms in the prime contractor's bid or proposal package.

Subcontractor Name Allon Engineering Inc		Project Name: West Hickman 7 (WE7) Wet Weather Storage Facilities Improvements- Contract No. 1 New Circle Road Crossing.	
Bid/ Proposal No. 80-2017	Assistance Agreement ID No. (if known)	Point of Contact Lilli Allon	
Address 2509 Lenlake Ct Lexington Ky 40513			
Telephone No. 859-229-7362	Email Address lmallen2509@yahoo.com		
Prime Contractor Name Midwest Mole Inc.		Issuing/Funding Entity:	

Contract Item Number	Description of Work Submitted to the Prime Contractor Involving Construction, Services, Equipment or Supplies	Price of Work Submitted to the Prime Contractor
	Construction Staking lump sum price includes all labor, supplies, and insurance but not bonding	\$5000⁰⁹
DBE Certified By: <input checked="" type="checkbox"/> DOT <input type="checkbox"/> SBA Other: KDOT		Meets/ exceeds EPA certification standards? <input type="checkbox"/> YES <input type="checkbox"/> NO <input checked="" type="checkbox"/> Unknown

² A DBE is a Disadvantaged, Minority, or Woman Business Enterprise that has been certified by an entity from which EPA accepts certification as described in 40 CFR 33.204-33.205 or certified by EPA. EPA accepts certifications from entities that meet or exceed EPA certification standards as described in 40 CFR 33.202.

¹ Subcontractor is defined as a company, firm, joint venture, or individual who enters into an agreement with a contractor to provide services pursuant to an EPA award of financial assistance.

EPA FORM 6100-3 (DBE Subcontractor Performance Form)

**Disadvantaged Business Enterprise (DBE) Program
 DBE Subcontractor Performance Form**

I certify under penalty of perjury that the forgoing statements are true and correct. Signing this form does not signify a commitment to utilize the subcontractors above. I am aware of that in the event of a replacement of a subcontractor, I will adhere to the replacement requirements set forth in 40 CFR Part 33 Section 33.302 (c).

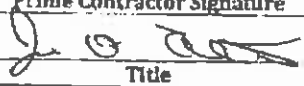
Prime Contractor Signature 	Print Name Jason D Miller
Title President	Date 6/23/2017

Subcontractor Signature 	Print Name Lilli Allen
Title President	Date 6-20-17

The public reporting and recordkeeping burden for this collection of information is estimated to average three (3) hours per response. Send comments on the Agency's need for this information, the accuracy of the provided burden estimates, and any suggested methods for minimizing respondent burden, including through the use of automated collection techniques to the Director, Collection Strategies Division, U.S. Environmental Protection Agency (28227), 1200 Pennsylvania Ave., NW, Washington, D.C. 20460. Include the OMB control number in any correspondence. Do not send the completed form to this address.

EPA FORM 6100-3 (DBE Subcontractor Performance Form)

**Disadvantaged Business Enterprise (DBE) Program
DBE Subcontractor Participation Form**

Please use the space below to report any concerns regarding the above EPA-funded project:

None

Subcontractor Signature <i>Lilli Allen</i>	Print Name <i>Lilli Allen</i>
Title <i>President</i>	Date <i>6-20-17</i>

The public reporting and recordkeeping burden for this collection of information is estimated to average three (3) hours per response. Send comments on the Agency's need for this information, the accuracy of the provided burden estimates, and any suggested methods for minimizing respondent burden, including through the use of automated collection techniques to the Director, Collection Strategies Division, U.S. Environmental Protection Agency (2822T), 1200 Pennsylvania Ave., NW, Washington, D.C. 20460. Include the OMB control number in any correspondence. Do not send the completed form to this address.

EPA FORM 6100-2 (DBE Subcontractor Participation Form)

Steven L. Beshear
Governor

Michael W. Hancock, P.E.
Secretary
Kentucky Transportation Cabinet

COMMONWEALTH OF KENTUCKY



Transportation Cabinet

certifies that

SOMETHIN BLOOMIN, LLC

1855 Norfolk Drive, Lexington, KY 40503

has met all eligibility requirements
to participate in the

Disadvantaged Business Enterprise Program

This certificate is issued pursuant to 49 CFR Part 26 and is subject to suspension or revocation.

A handwritten signature in black ink, appearing to be "M. Hancock", written over a horizontal line.

DBE Liaison Officer

April 30, 2016

Renewal Date

Kentucky
UNBRIDLED SPIRIT™

1.11 MWD BE SUBCONTRACTOR PERFORMANCE FORM



OMB Control No: 2050-0030
 Approved: 8/13/2013
 Approval Expires: 8/31/2015

Disadvantaged Business Enterprise (DBE) Program
 DBE Subcontractor Performance Form

This form is intended to capture the DBE¹ subcontractor's² description of work to be performed and the price of the work submitted to the prime contractor. An EPA Financial Assistance Agreement Recipient must require its prime contractor to have its DBE subcontractors complete this form and include all completed forms in the prime contractor's bid or proposal package.

Subcontractor Name <i>SOMETHAN BOWMAN</i>		Project Name <i>West Hickman 7(WH7) Wet Weather Storage Facilities Improvements- Contract No. 1 New Circle Road Crossing.</i>	
Bid/ Proposal No. <i>80-2017</i>	Assistance Agreement ID No. (if known)	Point of Contact <i>Cindy England</i>	
Address <i>1045 Higbee Mill Rd</i>			
Telephone No. <i>859-296-1624</i>		Email Address <i>S.Bowman@ad.com</i>	
Prime Contractor Name <i>Midwest Mole Inc.</i>		Issuing/Funding Entity:	

Contract Item Number	Description of Work Submitted to the Prime Contractor Involving Construction, Services, Equipment or Supplies	Price of Work Submitted to the Prime Contractor
	<i>Seeding & Straw</i>	<i>\$4725</i>
DBE Certified By: <input checked="" type="checkbox"/> DOT <input type="checkbox"/> SBA		Meets/ exceeds EPA certification standards? <input type="checkbox"/> YES <input type="checkbox"/> NO <input type="checkbox"/> Unknown
Other: _____		

¹ A DBE is a Disadvantaged, Minority, or Woman Business Enterprise that has been certified by an entity from which EPA accepts certifications as described in 40 CFR 33.204-33.205 or certified by EPA. EPA accepts certifications from entities that meet or exceed EPA certification standards as described in 40 CFR 33.202.

² Subcontractor is defined as a company, firm, joint venture, or individual who enters into an agreement with a contractor to provide services pursuant to an EPA award of financial assistance.

EPA FORM 6100-3 (DBE Subcontractor Performance Form)



OMB Control No: 2090-0030
Approved: 8/13/2013
Approval Expires: 8/31/2015

**Disadvantaged Business Enterprise (DBE) Program
DBE Subcontractor Performance Form**

I certify under penalty of perjury that the forgoing statements are true and correct. Signing this form does not signify a commitment to utilize the subcontractors above. I am aware of that in the event of a replacement of a subcontractor, I will adhere to the replacement requirements set forth in 40 CFR Part 33 Section 33.302 (c).

Prime Contractor Signature	Print Name
	Jason D Miller
Title	Date
President	6/23/2017

Subcontractor Signature	Print Name
	CINDY ENGLAND
Title	Date
OWNER	6-23-17

The public reporting and recordkeeping burden for this collection of information is estimated to average three (3) hours per response. Send comments on the Agency's need for this information, the accuracy of the provided burden estimates, and any suggested methods for minimizing respondent burden, including through the use of automated collection techniques to the Director, Collection Strategies Division, U.S. Environmental Protection Agency (2822T), 1200 Pennsylvania Ave., NW, Washington, D.C. 20460. Include the OMB control number in any correspondence. Do not send the completed form to this address.

EPA FORM 6100-3 (DBE Subcontractor Performance Form)

Amy Webster

From: Cindy England <sbloomin@aol.com>
Sent: Thursday, June 22, 2017 9:04 AM
To: Amy Webster
Subject: Re: Quote Request for West Hickman 7 (WH7) Wet Weather Storage Facilities Improvements- Contract no 1 New Circle Road Crossing- LFUCG Bid # 80-2017
Attachments: DBE.pdf

West Hickman 7 Wet Weather Storage
Seed and straw
\$1.05 SY

Cindy England
WBENC,DBE,SBE
sbloomin@aol.com

-----Original Message-----

From: Amy Webster <awebster@midwestmole.com>
To: 'Cindy England' <sbloomin@aol.com>
Cc: Amy Webster <awebster@midwestmole.com>
Sent: Thu, Jun 22, 2017 8:47 am
Subject: RE: Quote Request for West Hickman 7 (WH7) Wet Weather Storage Facilities Improvements- Contract no 1 New Circle Road Crossing- LFUCG Bid # 80-2017

Ok, just talked to our estimator . He said we would need about 4500 sq yards of seeding, and 200 feet of silt fence if you do that. He said we would do the rough restoration.

Amy Webster

Estimating Administrator



awebster@midwestmole.com

Midwest Mole Inc.
6814 W 350 N
Greenfield, IN 46140

P: 317-545-1335
F: 317-545-1558

From: Cindy England [mailto:sbloomin@aol.com]

Sent: Thursday, June 22, 2017 8:40 AM

To: Amy Webster <awebster@midwestmole.com>

Subject: Re: Quote Request for West Hickman 7 (WH7) Wet Weather Storage Facilities Improvements- Contract no 1 New Circle Road Crossing- LFUCG Bid # 80-2017

I'm going to be traveling today. I'm trying to bid this before I leave. I have access to all the documents but can't find a quantity page.

Cindy

Sent from my iPhone

On Jun 22, 2017, at 8:33 AM, Amy Webster <awebster@midwestmole.com> wrote:

Do you also do restoration of sites?

Amy Webster

Estimating Administrator

<image001.jpg>

awebster@midwestmole.com

Midwest Mole Inc.
6814 W 350 N
Greenfield, IN 46140

P: 317-545-1335

F: 317-545-1558

From: Cindy England [mailto:sbloomin@aol.com]

Sent: Thursday, June 22, 2017 8:26 AM

To: Amy Webster <awebster@midwestmole.com>

Subject: Re: Quote Request for West Hickman 7 (WH7) Wet Weather Storage Facilities Improvements- Contract no 1 New Circle Road Crossing- LFUCG Bid # 80-2017

Hi Amber, I am a DBE and want to bid any landscape work on this. Do you have any quantities on the seeding or sod?

Thanks,
Cindy
Somethin Bloomin

Sent from my iPhone

On Jun 20, 2017, at 8:39 AM, Amy Webster <awebster@midwestmole.com> wrote:

Good Afternoon,
We are looking for quote for Your Scope of Work for the above listed project we are bidding 6/23.
Please let us know if you are interested . I have attached invite that has all details, and link to plans and specs.

Need both forms that end with 16-17 at bottom back with quote.... Including a copy of the DBE certify.

Would like quotes on or before 6/21/2017

Thank you

Amy Webster
Estimating Administrator

<image001.jpg>

awebster@midwestmole.com

Midwest Mole Inc.
6814 W 350 N
Greenfield, IN 46140

P: 317-545-1335

F: 317-545-1558

<Invitation to Bid West Hickman 7 Wet Weather Storage Fac- Contract No. 1....doc>

<DBE Participation Form 00410-15.pdf>

<DBE Sub Form 00410-17.pdf>

<EPA DBE Participation Form 00410-14.pdf>

<MWDBE Sub Performance Form 00410-16.pdf>

1.12 MWDBE SUBCONTRACTOR UTILIZATION FORM



OMB Control No: 2090-0030
 Approved: 8/13/2013
 Approval Expires: 8/31/2015

**Disadvantaged Business Enterprise (DBE) Program
 DBE Subcontractor Utilization Form**

This form is intended to capture the prime contractor's actual and/or anticipated use of identified certified DBE¹ subcontractors² and the estimated dollar amount of each subcontract. An EPA Financial Assistance Agreement Recipient must require its prime contractors to complete this form and include it in the bid or proposal package. Prime contractors should also maintain a copy of this form on file.

Prime Contractor Name Midwest Mole Inc.		Project Name West Hickman 7(WH7) Wet Weather Storage Facilities Improvements- Contract No. 1 New Circle Road Crossing.	
Bid/ Proposal No. 80-2017	Assistance Agreement ID No. (if known) Not known	Point of Contact Ryan Barkdull	
Address 6814 W 350 N Greenfield, IN 46140			
Telephone No. 317-545-1335		Email Address rbarkdull@midwestmole.com	
Issuing/Funding Entity: LFUCG/ Kentucky Infrastructure Revolving Loan Fund			

I have identified potential DBE certified subcontractors	<input checked="" type="checkbox"/> YES	<input type="checkbox"/> NO	
If yes, please complete the table below. If no, please explain:			
Subcontractor Name/ Company Name	Company Address/ Phone/ Email	Est. Dollar Amt	Currently DBE Certified?
Somethin Bloomin	1045 Higbee Mill Rd, Lexington, KY 859-296-1624-sbloomin@aol.com	\$4725	Yes
Allen Engineering	2509 Lenlake Ct, Lexington, KY 859-229-7362 - lmallen2509@yahoo.com	\$5000	Yes
SLI Contracting	1141 Red Mile Rd, Lexington, KY 859-977-6640 info@slicontracting.com	dirt \$90 hr rock\$125hr	Yes

Continue on back if needed

¹ A DBE is a Disadvantaged, Minority, or Woman Business Enterprise that has been certified by an entity from which EPA accepts certifications as described in 40 CFR 33.204-33.205 or certified by EPA. EPA accepts certifications from entities that meet or exceed EPA certification standards as described in 40 CFR 33.202.

² Subcontractor is defined as a company, firm, joint venture, or individual who enters into an agreement with a contractor to provide services pursuant to an EPA award of financial assistance.

EPA FORM 6100-4 (DBE Subcontractor Utilization Form)

**Disadvantaged Business Enterprise (DBE) Program
 DBE Subcontractor Utilization Form**

I certify under penalty of perjury that the forgoing statements are true and correct. Signing this form does not signify a commitment to utilize the subcontractors above. I am aware of that in the event of a replacement of a subcontractor, I will adhere to the replacement requirements set forth in 40 CFR Part 33 Section 33.302 (c).

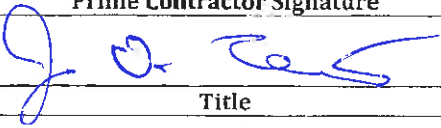
Prime Contractor Signature	Print Name
	Jason D Miller
Title	Date
President	6-27-2017

The public reporting and recordkeeping burden for this collection of information is estimated to average three (3) hours per response. Send comments on the Agency's need for this information, the accuracy of the provided burden estimates, and any suggested methods for minimizing respondent burden, including through the use of automated collection techniques to the Director, Collection Strategies Division, U.S. Environmental Protection Agency (2822T), 1200 Pennsylvania Ave., NW, Washington, D.C. 20460. Include the OMB control number in any correspondence. Do not send the completed form to this address.

EPA FORM 6100-4 (DBE Subcontractor Utilization Form)

1.13 MWDBE PARTICIPATION POLICY

West Hickman 7(WH7) Wet Weather Storage

PROJECT NAME: Lexington-Fayette Urban County Government

LFUCG BID NO. BID DATE:

A. Name, address and telephone number of contact person on all MWDBE matters:

Prime Contractor's Name: Midwest Mole Inc.
Contact Person: Ryan Barkdull
Address: 6814 W 350 N, Greenfield, IN 46140
Phone: 317-545-1335 Cell: 317-517-5697
Email: rbarkdull@midwestmole.com
Total Contract Amount: \$1,521,760.00

B. Total dollar amount/percent of contract of DBE participation: \$19,700./1.5%

C. Total dollar amount/percent of contract of MBE participation: N/A

D. Total dollar amount/percent of contract of WBE participation: N/A

E. Are certifications* for each MWDBE subcontractor enclosed; if no, please explain:
[X] Yes [] No

F. Are MWDBE subcontracts or letters of intent signed by both parties enclosed; if no, please explain:
[X] Yes [] No

G. List of DBE Subcontractors:

Name: Allen Engineering
Contact Person: Lilli Allen
Address: 2509 Lenlake Ct, Lexington, KY
Phone: 859-229-7362 Cell:
Email: lmallen2509@yahoo.com
Type of Contract: Sub
Work to be Done: Construction Staking
Amount: \$5000

H. List of DBE Subcontractors: DBE

Name: Somethin Bloomin
Contact Person: Cindy England
Address: 1045 Hibe Mill Rd, Lexington, KY
Phone: 859-296-1624 Cell:
Email: sbloomin@aol.com
Type of Contract: Sub
Work to be Done: Seeding
Amount: \$4725

I. List of WBE Subcontractors: DBE

Name: SLI Contracting
 Contact Person: Gwen Wilder
 Address: 1141 Red Mile Rd Lexington, KY 40504
 Phone: 859-977-6640 Cell: _____
 Email: info@slicontracting.com
 Type of Contract: Sub
 Work to be Done: Hauling
 Amount: \$90 hour for dirt, \$125 hr for Rock.

Attach additional sheets, if necessary.

*Self-certification: Self-certification of MWDBE firms will NOT be accepted as a valid form of certification of MWDBE status.

J. Information and documentation concerning efforts taken to comply with EPA's "six good faith efforts"

1. Ensure MWDBE construction firms or material suppliers are made aware of contracting opportunities to the fullest extent practicable through outreach and recruitment activities; including placing MWDBEs on solicitation lists and soliciting them whenever they are potential sources. A good source for a list of MWDBEs is the Kentucky Transportation's website: <http://transportation.ky.gov/Civil-Rights-and-Small-Business-Development/Pages/Certified-DBE-Directory.aspx>.

The prime contractor certifies that a bidders list (see example sheet below) of qualified vendors, including MWDBEs, was developed for current and future solicitations and that the list will be maintained. *Submit a copy of the list as documentation.*

2. Make information on forthcoming opportunities available to MWDBEs and arrange time frames for contracts and establish delivery schedules, where the requirements permit, in a way that encourages and facilitates participation by MWDBEs in the competitive process; including, whenever possible, posting solicitation for bids or proposals for a sufficient amount of time as to receive a competitive bid or proposal pool.

The prime contractor certifies that every opportunity was provided to a number of MWDBEs to encourage their participation in the competitive process and that an adequate amount of time was provided for response.

- a. List each MWDBE construction firm or material supplier to which a solicitation was attempted. *Submit copies of letters, emails, faxes, telecommunication logs, certified mail receipts, returned envelopes, certified mail return receipts, etc. as documentation.*

Company Name and Phone Number: See Attached Sheet

Area of Work Expertise: Part of Good Faith Effort

Date of any Follow-Ups and Person Spoke to: _____

- b. Advertisements, if applicable: List each publication in which an announcement or notification was placed. *Submit a tear sheet of each announcement from each publication as documentation.*

Name of Publication: SBA-Sub-Net, Key News Journal, The Blue Book

Date(s) of Advertisement: 6/14/2017- 6/15/2017- 6/14/2017

Specific Subcontract Areas Announced: MWDBE and VOSB's for Traffic Control,

Landscape/ Restoration, Temp Access Roads, Pipe Suppliers, and Shoring.

- c. Other, if applicable: List each notification method in which an announcement or outreach was used; list serve, public meeting, etc. *Submit applicable information to document effort.*

Method of Notification: N/A

Date(s) of Notification: _____

3. Consider in the contracting process whether firms competing for large contracts could subcontract with MWDBEs; including dividing total requirements, when economically feasible, into smaller tasks or quantities to permit maximum participation by MWDBEs in the competitive process.

The prime contractor certifies that the project was broken into its basic elements (i.e. dirt hauling, landscaping, painting, pipe installation, material supplies, etc.) and that a determination was made whether it's economically feasible to bid the elements separately and that the analysis of this effort was documented with a short memo to the project file.

4. Establishing delivery schedules, where the requirement permits, which encourage participation by small and minority business, and women's business enterprises.

The prime contractor certifies that they established delivery schedules which would allow MWDBEs to participate in the projects.

5. Use the services and assistance of the Small Business Administration (SBA) and the Minority Business Development Agency (MBDA) of the U.S. Department of Commerce. The easiest way to utilize the services of SBA and MBDA is to visit their websites: www.sba.gov and www.mbda.gov and use the electronic tools available there or you may send the nearest SBA and MBDA office a certified letter that generally describes the solicitation, the dates it will be open, the types of vendors you are seeking and applicable SIC or NAIC codes if known. You may also use the services and assistance of the Kentucky Procurement Assistance Program (KPAP). The easiest way to utilize the services of KPAP is to send an email: ced.kpap@ky.gov and provide information on forthcoming opportunities available to MWDBEs.

The prime contractor certifies that the assistance of the SBA, MBDA, and/or KPAP was utilized. *Submit pages printed off the SBA and MBDA websites which evidence efforts to register a solicitation on those sites or submit copies of the letter send and certified mail receipt as documentation; submit copies of emails with KPAP as documentation.*

6. If a subcontractor awards any subcontracts, require the subcontractor to take the steps in numbers 1 and 5 above.

The prime contractor certifies that subcontractors used for this project will be required to follow the steps of the "six good faith efforts" as listed above.

Signature and Date:

To the best of my knowledge and belief, all "six good faith efforts" have been met and the information contained in this document is true and correct; the document has been duly authorized by the legal representative.



Signature

Jason D Miller/ President

Print Name and Title

6-27-2017

Date

1.14 EQUAL EMPLOYMENT OPPORTUNITY AFFIRMATIVE ACTION POLICY

It is the policy of Midwest Mole Inc.
(Name of Bidder)

to assure that all applicants for employment and all employees are treated on a fair and equitable basis without regard to their race, religion, sex, color, handicap, natural origin or age.

Such action shall include employment, promotion, demotion, recruitment or recruitment advertising, layoff or termination, rates of pay and other forms of compensation, and selection for training, whether apprenticeship and/or on-the-job-training.

Furthermore, this company agrees to make special recruitment efforts to hire the protected class whenever feasible. This company also agrees to adhere to all applicable federal, state, and local laws relating to Equal Employment Opportunity for all individuals. We Agree.

1.15 WORKFORCE ANALYSIS FORM

Name of Organization: Midwest Mole Inc.

Categories	Total		White (not Hispanic or Latino)		Hispanic or Latino		Black or African-American (not Hispanic or Latino)		Native Hawaiian and other Pacific Islander (not Hispanic or Latino)		Asian (not Hispanic or Latino)		American Indian or Alaskan Native (not Hispanic or Latino)		Two or more races (not Hispanic or Latino)		Total	
	M	F	M	F	M	F	M	F	M	F	M	F	M	F	M	F	M	F
Administrators	6	5									1						6	5
Professionals	8	7	1														7	1
Superintendents	3	3															3	
Supervisors																		
Foremen	18	14	3										1				18	
Technicians	3	3															3	
Protective Service																		
Para-Professionals																		
Office/Clerical	10	3	6					1									3	7
Skilled Craft	38	33			3		1						1				38	
Service/Maintenance	8	7					1										8	
Total	94	75	7				2	1					2				86	8

Prepared By: Ryan Barkdull

Date 6 / 23 / 17

1.16 EVIDENCE OF INSURABILITY

LEXINGTON-FAYETTE UBAN COUNTY GOVERNMENT CONTRUCTION PROJECT
 (Use separate form for each Agency or Brokerage agreeing to provide coverage)

Names Insured: Midwest Mole Inc.
 Address: 6814 W 350 N, Greenfield, IN 46140
 Project to be insured: West Hickman 7(WH7) Wet Weather Storage Facilities Improvements Contract No.1 New Circle Rd Crossing

In lieu of obtaining certificates of insurance at this time, the undersigned agrees to provide the above Named Insured with the minimum coverage listed below. These are outlined in the Insurance and Risk Management of Section 00600 - Bonds and Certifications, including all requirements, and conditions:

Article Items	Coverage	Minimum Limits and Policy Requirements	Limits Provided to Insured	Name of Insurer	A.M. Best's	
					Code	Rating
1.05.D.1	CGL	\$1,000,000/per occ., \$2,000,000/aggregate or \$2,000,000 combined single limit Requirements (a) through (e)	\$1,000,000 per occ. \$2,000,000 aggregate	Charter Oak Fire Ins Co	002516	A++
1.05.D.1	Auto	Combined single \$1,000,000/per occ. aggregate Requirements (a) through (c)	Combined single \$1,000,000/per occ. aggregate	Charter Oak Fire Ins Co	002516	A++
1.05.D.1	WC	\$ 500,000/500,000 Statutory	Statutory	Charter Oak Fire Ins Co	002516	A++
1.05.D.1	Employer's Liability	\$500,000	\$500,000	Charter Oak Fire Ins Co	002516	A++

Section 00600 includes required provisions, statements regarding insurance requirements, and the undersigned agrees to abide by all provisions for the coverage's checked above unless stated otherwise when submitting

Garrett-Stotz Company S. Annette Mullet
 Agency or Brokerage Name of Authorized Representative
755 West Carmel Drive, Suite 201 Vice President
 Street Address Title
Carmel, IN 46032 Authorized Signature
 City
317-569-9970 6/21/2017
 Telephone Number Date

NOTE: Authorized signatures may be the agent's if agent has placed insurance through an agency agreement with the insurer. If insurance is brokered, authorized signature must be that of authorized representative of insurer.

IMPORTANT: CONTRACT MAY NOT BE AWARDED IF A COMPLETED AND SIGNED COPY OF THIS FORM FOR ALL COVERAGES LISTED ABOVE IS NOT PROVIDED.

1.17 DEBARRED FIRMS

PROJECT NAME: West Hickman 7(WH7) Wet Weather Storage Facilities Improvements.
Contract No. 1 New Circle Road Crossing.

LFUCG BID NO.: 80-2017

**LEXINGTON-FAYETTE URBAN COUNTY GOVERNMENT
LEXINGTON, KY**

All prime Contractors shall certify that Subcontractors have not and will not be awarded to any firms that has been debarred for noncompliance with the Federal Labor Standards, Title VI of the Civil Rights Act of 1964 As Amended, Executive Order 11246 As Amended or any other Federal Law.

All Bidders shall complete the Debarment Certification in duplicate and submit both copies to the Owner with the Bid Form. The Owner (grantee) shall transmit one copy to the Lexington-Fayette Urban County Government, Division of Community Development within fourteen (14) days after Bid opening.

The undersigned hereby certifies that the firm of Midwest Mole Inc. has not and will not award a subcontract, in connection with any Agreement award to it as the result of this bid, to any firm that has been debarred for noncompliance with the Federal Labor Standards, Title VI of the Civil Rights Act of 1964, Executive Order 11246 As Amended or any Federal Law.

Midwest Mole Inc.

Name of Firm Submitting Bid

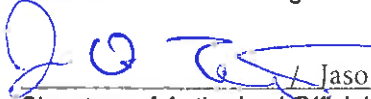
Jason D Miller

Signature of Authorized Official

President

Title

6/27/2017

Date

1.18 DEBARMENT CERTIFICATION

All Contractors/Subcontractors shall complete this certification.

The Contractor/Subcontractor certifies in accordance with Executive Order 12549 (Debarment and Suspension 2/18/86) that to the best of its knowledge and belief, that it and its principals:

- 1) Are not presently debarred, suspended, proposed for debarment, declared negligible, or voluntarily excluded from covered transactions or contract by any Federal department or agency for noncompliance with the Federal Labor Standards, Title VI of the Civil Rights Act of 1964 As Amended, Executive Order 11246 As Amended or any other Federal Law.
 - a) Have not within a three year period preceding this Bid been convicted of or had a civil judgment rendered against them for commission of fraud or a criminal offense in connection with obtaining, attempting to obtain, or performing a public (Federal, State or local) transaction or contract under a public transaction; violation of Federal or State antitrust statutes or commission of embezzlement, theft, forgery, bribery, falsification or destruction of records, making false statements or receiving stolen property;
 - b) Are not presently indicted for or otherwise criminally or civilly charged by a government entity (Federal, State or local) with commission of any of the offenses enumerated in paragraph (1)(a) of this certification; and
 - c. Have not within a three (3) year period preceding this Bid has one or more public (Federal, State or local) transactions or contracts terminated for cause or default.
- 2) Where the Contractor is unable to certify to any of the statements in this certification, such prospective contractors shall attach an explanation to this certification form.

Firm Name: Midwest Mole Inc.
Project: West Hickman 7(WH7) Wet Weather Storage Facilities Improvements.
Contract No. 1 New Circle Road Crossing.
Printed Name: Jason D Miller
Title of Authorized Representative: President
Signature: 
Date: 6/27/2017

1.19 CERTIFICATION REGARDING LOBBYING

Certification for Contracts, Grants, Loans, and Cooperative Agreements

The undersigned certifies, to the best of his or her knowledge and belief, that:

- (1) No Federal appropriated funds have been paid or will be paid, by or on behalf of the undersigned, to any person for influencing or attempting to influence an officer or employee of an agency, a Member of Congress, an officer or employee of Congress, or an employee of a Member of Congress in connection with the awarding of any Federal contract, the making of any Federal grant, the making of any Federal loan, the entering into of any cooperative agreement, and the extension, continuation, renewal, amendment, or modification of any Federal contract, grant, loan, or cooperative agreement.
- (2) If any funds other than Federal appropriated funds have been paid or will be paid to any person for influencing or attempting to influence an officer or employee of any agency, a Member of Congress, an officer or employee of Congress, or an employee of a Member of Congress in connection with this Federal contract, grant, loan, or cooperative agreement, the undersigned shall complete and submit Standard Form-LLL, "Disclosure Form to Report Lobbying," in accordance with its instructions.
- (3) The undersigned shall require that the language of this certification be included in the award documents for all sub-awards at all tiers (including subcontracts, sub-grants, and contracts under grants, loans, and cooperative agreements) and that all sub-recipients shall certify and disclose accordingly.

This certification is a material representation of fact upon which reliance was placed when this transaction was made or entered into. Submission of this certification is a prerequisite for making or entering into this transaction imposed by Section 1352, Title 31, U.S. Code. Any person who fails to file the required certification shall be subject to a civil penalty for not less than \$10,000 and not more than \$100,000 for each such failure.

Jason D Miller/ President

Typed Name & Title of Authorized Representative



Signature of Authorized Representative

6/27/2017

Date

_____ I am unable to certify to the above statements. My explanation is attached.

BID BOND

Bond Number: N/A

KNOW ALL MEN BY THESE PRESENTS, that we Midwest Mole, Inc.

as principal (the "Principal") and Continental Casualty Company

hereinto called Surety, are held and firmly bound unto

LEXINGTON-FAYETTE URBAN COUNTY GOVERNMENT
200 East Main Street, Third Floor
Lexington, Kentucky 40507

as obligee (the "Obligee"), in the penal sum of five percent (5%) of the accompanying bid price dollars for the payment of which sum well and truly to be made, the said Principal and the said Surety, bind ourselves, our heirs, executors, administrators, successors and assigns, jointly and severally, firmly by these presents.

WHEREAS, the Principal has submitted a bid for West Hickman 7 (WH7) Wet Weather Storage Facilities - Contract #1 New Circle Road Crossing
LFUCG Bid No. 80-2017 Trenchless Installation

NOW, THEREFORE, if the Obligee shall accept the bid of the Principal within the period specified therein, or, if no period be specified, within ninety (90) days after opening, and the Principal shall enter into a contract with the Obligee in accordance with the terms of such bid, and give such bond or bonds as may be specified in the bidding or contract documents, or in the event of the failure of the Principal to enter into such contract and give such bond or bonds, if the Principal shall pay to the Obligee the difference in money not to exceed the penal sum hereof between the amount specified in said bid and such larger amount for which the Obligee may in good faith contract with another party to perform the work covered by said bid, then this obligation shall be null and void; otherwise to remain in full force and effect. In no event shall the liability hereunder exceed the penal sum thereof.

PROVIDED AND SUBJECT TO THE CONDITION PRECEDENT, that any claim by Obligee under this bond must be submitted in writing by registered mail, to the attention of the Surety Law Department at the address above, within 120 days of the date of this bond. Any suit under this bond must be instituted before the expiration of one (1) year from the date of this bond. If the provisions of this paragraph are void or prohibited by law, the minimum period of limitation available to sureties as a defense in the jurisdiction of the suit shall apply.

DATED as of this 27th day of June, 2017.

WITNESS / ATTEST:

Jane P. Edwards
Principal (Secretary)

Midwest Mole, Inc.
Principal

By: [Signature] (seal)
Name: Jason D Miller
Title: President

Kimberly C. Kirkwood
Surety (Secretary)

Continental Casualty Company
Surety

By: [Signature] (seal)
Name: Sheree Hsieh
Title: Attorney-in-Fact

POWER OF ATTORNEY APPOINTING INDIVIDUAL ATTORNEY-IN-FACT

Know All Men By These Presents, That Continental Casualty Company, an Illinois insurance company, National Fire Insurance Company of Hartford, an Illinois insurance company, and American Casualty Company of Reading, Pennsylvania, a Pennsylvania insurance company (herein called "the CNA Companies"), are duly organized and existing insurance companies having their principal offices in the City of Chicago, and State of Illinois, and that they do by virtue of the signatures and seals herein affixed hereby make, constitute and appoint

Michael M Bill, Edward L Mournighan, Michael H Bill, Cynthia L Jenkins, Ginger J Krahn, Sheree Hsieh, Brenda Johnston, Cindy H Stellhorn, Kimberly E Kinkead, Rebecca A Virt , Individually

of Indianapolis, IN, their true and lawful Attorney(s)-in-Fact with full power and authority hereby conferred to sign, seal and execute for and on their behalf bonds, undertakings and other obligatory instruments of similar nature

- In Unlimited Amounts -

and to bind them thereby as fully and to the same extent as if such instruments were signed by a duly authorized officer of their insurance companies and all the acts of said Attorney, pursuant to the authority hereby given is hereby ratified and confirmed.

This Power of Attorney is made and executed pursuant to and by authority of the By-Law and Resolutions, printed on the reverse hereof, duly adopted, as indicated, by the Boards of Directors of the insurance companies.

In Witness Whereof, the CNA Companies have caused these presents to be signed by their Vice President and their corporate seals to be hereto affixed on this 8th day of June, 2015.



Continental Casualty Company
National Fire Insurance Company of Hartford
American Casualty Company of Reading, Pennsylvania

Paul T. Bruflat
Paul T. Bruflat Vice President

State of South Dakota, County of Minnehaha, ss:

On this 8th day of June, 2015, before me personally came Paul T. Bruflat to me known, who, being by me duly sworn, did depose and say: that he resides in the City of Sioux Falls, State of South Dakota; that he is a Vice President of Continental Casualty Company, an Illinois insurance company, National Fire Insurance Company of Hartford, an Illinois insurance company, and American Casualty Company of Reading, Pennsylvania, a Pennsylvania insurance company described in and which executed the above instrument; that he knows the seals of said insurance companies; that the seals affixed to the said instrument are such corporate seals; that they were so affixed pursuant to authority given by the Boards of Directors of said insurance companies and that he signed his name thereto pursuant to like authority, and acknowledges same to be the act and deed of said insurance companies.

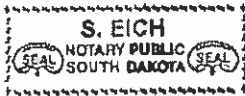

My Commission Expires February 12, 2021

S. Eich
S. Eich Notary Public

CERTIFICATE

I, D. Bult, Assistant Secretary of Continental Casualty Company, an Illinois insurance company, National Fire Insurance Company of Hartford, an Illinois insurance company, and American Casualty Company of Reading, Pennsylvania, a Pennsylvania insurance company do hereby certify that the Power of Attorney herein above set forth is still in force, and further certify that the By-Law and Resolution of the Board of Directors of the insurance companies printed on the reverse hereof is still in force. In testimony whereof I have hereunto subscribed my name and affixed the seal of the said insurance companies this 27th day of June, 2017.



Continental Casualty Company
National Fire Insurance Company of Hartford
American Casualty Company of Reading, Pennsylvania

D. Bult
D. Bult Assistant Secretary

Authorizing By-Laws and Resolutions

ADOPTED BY THE BOARD OF DIRECTORS OF CONTINENTAL CASUALTY COMPANY:

This Power of Attorney is made and executed pursuant to and by authority of the following resolution duly adopted by the Board of Directors of the Company at a meeting held on May 12, 1995:

"RESOLVED: That any Senior or Group Vice President may authorize an officer to sign specific documents, agreements and instruments on behalf of the Company provided that the name of such authorized officer and a description of the documents, agreements or instruments that such officer may sign will be provided in writing by the Senior or Group Vice President to the Secretary of the Company prior to such execution becoming effective."

This Power of Attorney is signed by Paul T. Bruflat, Vice President, who has been authorized pursuant to the above resolution to execute power of attorneys on behalf of Continental Casualty Company.

This Power of Attorney is signed and sealed by facsimile under and by the authority of the following Resolution adopted by the Board of Directors of the Company by unanimous written consent dated the 25th day of April, 2012:

"Whereas, the bylaws of the Company or specific resolution of the Board of Directors has authorized various officers (the "Authorized Officers") to execute various policies, bonds, undertakings and other obligatory instruments of like nature; and

Whereas, from time to time, the signature of the Authorized Officers, in addition to being provided in original, hard copy format, may be provided via facsimile or otherwise in an electronic format (collectively, "Electronic Signatures"); Now therefore be it resolved: that the Electronic Signature of any Authorized Officer shall be valid and binding on the Company."

ADOPTED BY THE BOARD OF DIRECTORS OF NATIONAL FIRE INSURANCE COMPANY OF HARTFORD:

This Power of Attorney is made and executed pursuant to and by authority of the following resolution duly adopted by the Board of Directors of the Company by unanimous written consent dated May 10, 1995:

"RESOLVED: That any Senior or Group Vice President may authorize an officer to sign specific documents, agreements and instruments on behalf of the Company provided that the name of such authorized officer and a description of the documents, agreements or instruments that such officer may sign will be provided in writing by the Senior or Group Vice President to the Secretary of the Company prior to such execution becoming effective."

This Power of Attorney is signed by Paul T. Bruflat, Vice President, who has been authorized pursuant to the above resolution to execute power of attorneys on behalf of National fire Insurance Company of Hartford.

This Power of Attorney is signed and sealed by facsimile under and by the authority of the following Resolution adopted by the Board of Directors of the Company by unanimous written consent dated the 25th day of April, 2012:

"Whereas, the bylaws of the Company or specific resolution of the Board of Directors has authorized various officers (the "Authorized Officers") to execute various policies, bonds, undertakings and other obligatory instruments of like nature; and

Whereas, from time to time, the signature of the Authorized Officers, in addition to being provided in original, hard copy format, may be provided via facsimile or otherwise in an electronic format (collectively, "Electronic Signatures"); Now therefore be it resolved: that the Electronic Signature of any Authorized Officer shall be valid and binding on the Company."

ADOPTED BY THE BOARD OF DIRECTORS OF AMERICAN CASUALTY COMPANY OF READING, PENNSYLVANIA:

This Power of Attorney is made and executed pursuant to and by authority of the following resolution duly adopted by the Board of Directors of the Company by unanimous written consent dated May 10, 1995:

"RESOLVED: That any Senior or Group Vice President may authorize an officer to sign specific documents, agreements and instruments on behalf of the Company provided that the name of such authorized officer and a description of the documents, agreements or instruments that such officer may sign will be provided in writing by the Senior or Group Vice President to the Secretary of the Company prior to such execution becoming effective."

This Power of Attorney is signed by Paul T. Bruflat, Vice President, who has been authorized pursuant to the above resolution to execute power of attorneys on behalf of American Casualty Company of Reading, Pennsylvania.

This Power of Attorney is signed and sealed by facsimile under and by the authority of the following Resolution adopted by the Board of Directors of the Company by unanimous written consent dated the 25th day of April, 2012:

"Whereas, the bylaws of the Company or specific resolution of the Board of Directors has authorized various officers (the "Authorized Officers") to execute various policies, bonds, undertakings and other obligatory instruments of like nature; and

Whereas, from time to time, the signature of the Authorized Officers, in addition to being provided in original, hard copy format, may be provided via facsimile or otherwise in an electronic format (collectively, "Electronic Signatures"); Now therefore be it resolved: that the Electronic Signature of any Authorized Officer shall be valid and binding on the Company."

**CONSENT IN LIEU OF REGULAR
MEETING OF THE BOARD OF DIRECTORS**

MIDWEST MOLE, INC.

Effective Date: August 28, 2012

The undersigned, being all of the Board of Directors of **Midwest Mole, Inc.**, an Indiana corporation (hereafter referred to as the "Corporation"), under the provisions of the Indiana Business Corporation Law, as codified in I.C. 23-1-34-2, hereby adopts the following resolution by written consent and authorizes the actions described therein to be taken by the Corporation in lieu of the regular meeting of the Board of Directors of the Corporation.

RESOLVED: That each of the following persons be, and they hereby are, elected Officers of the Corporation, set forth opposite his/her name, to hold such office(s) until his/her successor(s) is duly elected and qualified or until his/her earlier resignation, death or removal from office:

Daniel L. Liotti	Chief Executive Officer
Jason D. Miller	President
Joanne P. Edwards	Secretary/Treasurer

IN WITNESS WHEREOF, the Directors of the Corporation has executed this Consent in Lieu of Regular Meeting of the Board of Directors, to be deemed effective as of August 28, 2012.

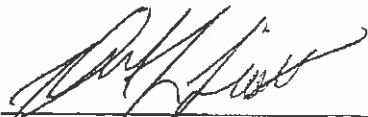

Daniel L. Liotti



Jason D. Miller

Commonwealth of Kentucky
Alison Lundergan Grimes, Secretary of State

Alison Lundergan Grimes
Secretary of State
P. O. Box 718
Frankfort, KY 40602-0718
(502) 564-3490
<http://www.sos.ky.gov>

Certificate of Authorization

Authentication number: 190374
Visit <https://app.sos.ky.gov/ftshow/certvalidate.aspx> to authenticate this certificate.

I, Alison Lundergan Grimes, Secretary of State of the Commonwealth of Kentucky, do hereby certify that according to the records in the Office of the Secretary of State,

MIDWEST MOLE, INC.

, a corporation organized under the laws of the state of Indiana, is authorized to transact business in the Commonwealth of Kentucky, and received the authority to transact business in Kentucky on August 4, 1982.

I further certify that all fees and penalties owed to the Secretary of State have been paid; that an application for certificate of withdrawal has not been filed; and that the most recent annual report required by KRS 14A.6-010 has been delivered to the Secretary of State.

IN WITNESS WHEREOF, I have hereunto set my hand and affixed my Official Seal at Frankfort, Kentucky, this 8th day of June, 2017, in the 226th year of the Commonwealth.



Alison Lundergan Grimes
Secretary of State
Commonwealth of Kentucky
190374/0169213

