

All standard wiring entering or exiting the cab shall be routed through sealed bulkhead connectors to protect against water intrusion into the cab.

3-88 BATTERY CABLE INSTALLATION

All 12-volt battery cables and battery cable harnessing installed by the apparatus manufacturer shall conform to the following requirements:

SAE J1127 - Battery Cable

SAE J561 - Electrical terminals, eyelets and spade type

SAE J562 - Nonmetallic loom

SAE J836A - Automotive metallurgical joining

SAE J1292 - Automotive truck, truck-tractor, trailer and motor coach wiring

NFPA 1901 - Standard for automotive fire apparatus

Battery cables and battery cable harnessing shall be installed utilizing the following guidelines:

All battery cables and battery harnesses shall have a permanent label attached for easy identification of the harness part number and fabrication date.

Splices shall not be allowed on battery cables or battery cable harnesses.

For ease of identification and simplified use, battery cables shall be color coded. All positive battery cables shall be red in color or wrapped in red loom the entire length of the cable. All negative battery cables shall be black in color.

For ease of identification, all positive battery cable isolated studs throughout the cab and chassis shall be red in color.

For increased reliability and reduced maintenance, all electrical buss bars located on the exterior of the apparatus shall be coated to prevent corrosion.

3-89 ELECTRICAL COMPONENT INSTALLATION

All lighting used on the apparatus shall be, at a minimum, a two (2) wire light grounded through a wired connection to the battery system. Lights using an apparatus metal structure for grounding shall not be allowed.

An operational test shall be conducted to ensure that any equipment that is permanently attached to the electrical system is properly connected and in working order. The results of the tests shall be recorded and provided to the purchaser at time of delivery.

3-90 BATTERY SYSTEM

Six (6) 12 volt, Exide Model 31A950X1W batteries that include the following features shall be provided:

- 950 CCA, cold cranking amps
- 190 amp reserve capacity

- High cycle
- Group 31
- Rating of 5700 CCA at 0 degrees Fahrenheit
- 1140 minutes of reserve capacity
- SAE Posts

Each battery case shall be a black polypropylene material with a vertically ribbed container for increased vibration resistance. The cover shall be manifold vented with a central venting location to allow a 45 degree tilt capacity.

The inside of each battery shall consist of a "maintenance free" grid construction with poly wrapped separators and a flooded epoxy bottom anchoring for maximum vibration resistance.

3-91 STARTING SYSTEM

A single starting system shall be provided.

An ignition switch and starter button shall be located on the instrument panel.

3-92 MASTER BATTERY SWITCH

A master battery switch, to activate the battery system, shall be provided inside the cab within easy reach of the driver.

An indicator light shall be provided on the instrument panel to notify the driver of the status of the battery system.

3-93 BATTERY COMPARTMENTS

The batteries shall be stored in well-ventilated compartments that are located under the cab and bolted directly to the chassis frame. The battery compartments shall be constructed of 3/16" steel plate and be designed to accommodate a maximum of three (3) group 31 batteries in each compartment. The compartments shall include formed fit heavy-duty roto-molded polyethylene battery tray inserts with drains on each side of the frame rails. The batteries shall be mounted inside of the roto-molded trays.

3-94 JUMPER STUDS

One (1) set of battery jumper studs with plastic color-coded covers shall be installed on the battery box on the driver's side. This shall allow enough room for easy jumper cable access.

3-95 BATTERY CHARGER

There shall be a Kussmaul 1200, Model 091-187-12-Remote battery charger provided. A bar graph display indicating the state of charge shall be provided.

The charger shall have a maximum output of 40 amps and a fully automatic regulation.

The battery charger shall be wired to the AC shoreline inlet through an AC receptacle adjacent to this battery charger.

Battery charger shall be located in the front left body compartment, mounted the inside wall as high as possible.

The battery charger indicator shall be located near the driver's seat riser.

3-96 KUSSMAUL AUTO EJECT FOR SHORELINE

One (1) shoreline receptacle shall be provided to operate the dedicated 120-volt circuits on the truck without the use of the generator.

The shoreline receptacle shall be provided with a NEMA 5-20, 120 volt, 20 amp, straight blade Kussmaul Super auto eject plug with a red weatherproof cover. The cover is spring loaded to close, preventing water from entering when the shoreline is not connected.

The unit is completely sealed to prevent road dirt contamination.

A solenoid wired to the vehicle's starter is energized when the engine is started. This instantaneously drives the plug from the receptacle.

An internal switch arrangement shall be provided to disconnect the load prior to ejection to eliminate arcing of the connector contacts.

The shoreline shall be connected to the battery charger.

A mating connector body shall also be supplied with the loose equipment.

The shoreline receptacle shall be located in the driver's side lower step well of the cab.

3-97 ALTERNATOR

A C.E. Niehoff, Model C680-1, alternator shall be provided. It shall have a rated output current of 430 amp as measured by SAE method J56. Also, it shall have a custom three (3)-set point voltage regulator, manufactured by C. E. Niehoff. The alternator shall be connected to the power and ground distribution system with heavy-duty cables sized to carry the full rated alternator output.

3-98 ELECTRONIC LOAD MANAGER

An electronic load management (ELM) system shall be provided that monitors the vehicles 12-volt electrical system, automatically reducing the electrical load in the event of a low voltage condition, and automatically restoring the shed electrical loads when a low voltage condition expires. This ensures the integrity of the electrical system.

For improved reliability and ease of use, the load manager system shall be an integral part of the vehicle's solid state control system requiring no additional components to perform load management tasks. Load management systems which require additional components shall not be allowed.

The system shall include the following features:

System voltage monitoring.

A shed load shall remain inactive for a minimum of five minutes to prevent the load from cycling on and off.

Sixteen available electronic load shedding levels.

Priority levels can be set for individual outputs.

High Idle to not be controlled by the load manager.

If enabled:

“Load Man Hi-Idle On” shall display on the information center.

Hi-Idle shall not activate until 30 seconds after engine start up.

Individual switch "on" indicator to flash when the particular load has been shed.

The information center indicates system voltage.

The information center, where applicable, includes a "Load Manager" screen indicating the following:

Load managed items list, with priority levels and item condition.

Individual load managed item condition:

ON = not shed

SHED = shed

3-99 SEQUENCER

A sequencer shall be provided that automatically activates and deactivates vehicle loads in a preset sequence thereby protecting the alternator from power surges. This sequencer operation shall allow a gradual increase or decrease in alternator output, rather than loading or dumping the entire 12 volt load to prolong the life of the alternator.

For improved reliability and ease of use, the load sequencing system shall be an integral part of the vehicle's solid state control system requiring no additional components to perform load sequencing tasks. Load sequencing systems which require additional components shall not be allowed.

Emergency light sequencing shall operate in conjunction with the emergency master light switch. When the emergency master switch is activated, the emergency lights shall be activated one by one at half-second intervals. Sequenced emergency light switch indicators shall flash while waiting for activation.

When the emergency master switch is deactivated, the sequencer shall deactivate the warning light loads in the reverse order.

Sequencing of the following items shall also occur, in conjunction with the ignition switch, at half-second intervals:

Cab Heater and Air Conditioning

Crew Cab Heater (if applicable)

Crew Cab Air Conditioning (if applicable)

Exhaust Fans (if applicable)

Third Evaporator (if applicable)

3-100 SHORELINE POWER OUTLETS

Two (2) 120 volt outlets shall be located in cab and apparatus body. The outlets shall be wired into the shoreline receptacle and the onboard generator to provide a 120 volt power source for fire department equipment. The exact location of the outlets to be determined at the pre-construction conference.

4-0 EXTERIOR LIGHTING

Exterior lighting shall comply with Federal Department of Transportation, Federal Motor Vehicle Safety Standards and National Fire Protection Association requirements in effect at time of proposal.

Front headlights shall be rectangular shaped, quad style halogen lights mounted in the front trim housing. Headlights shall consist of two (2) lights mounted in the front trim on each side of the cab grill. The outside light on each side shall contain a low and high beam. The inside light on each side shall contain a high beam light only.

- One (1) LED combination directional/marker light shall be located in the outside corners of the headlamp trim housing on each side.

- Three (3) LED identification lamps shall be installed in the center of the cab on the trim above the windshield.

- Four (4) LED clearance lamp shall be installed, one (1) each side, facing forward and one (1) each side, facing the side on the trim above the windshield.

4-1 REAR ID/MARKER DOT LIGHTING

The three (3) identification lights located at the rear shall be installed per the following:

- LED
- As close as practical to the vertical centerline.
- Centers spaced not less than six (6) inches or more than twelve (12) inches apart.
- Red in color.
- All at the same height.

The four (4) clearance lights located at the rear shall be installed per the following:

- LED
- To indicate the overall width of the vehicle.
- One (1) each side of the vertical centerline.
- All at the same height.
- As near the top as practical.
- To be visible from the rear and the side.
- One (1) each side, facing the side.

- One (1) each side, facing the rear.

4-2 MARKER LIGHTS

There shall be one (1) pair of amber and red LED marker lights with rubber arms; located one (1) each side at the rear of the apparatus body. The amber lens shall face the front and the red lens shall face the rear of the truck.

These lights shall be activated with the running lights of the vehicle.

4-3 REAR FMVSS LIGHTING

The rear stop/tail and directional lighting shall consist of the following:

Two (2) Whelen Model 60R00BRR red LED combination stop/tail lights.

Two (2) Whelen Model 60A00TAR, amber LED populated arrow turn signal lights.

These lights shall be installed at the rear of the truck in a polished housing.

Four (4) red reflectors shall be provided.

A Weldon, Model 23882-2600-00, license plate bracket shall be mounted on the driver's side above the warning lights. A Weldon, Model 9186-23882-30, step lamp shall illuminate the license plate.

Two (2) Whelen, Model: 60C00VCR, LED backup lights shall be provided.

4-4 LIGHTING BEZEL

Two (2) Whelen, Model CAST4V, four (4) light aluminum housings shall be provided for mounting the rear lights.

4-5 BACK-UP ALARM

A PRECO, Model 1040, solid-state electronic audible back-up alarm that actuates when the truck is shifted into reverse shall be provided. The device shall sound at 60 pulses per minute and automatically adjust its volume to maintain a minimum ten (10) DBA above surrounding environmental noise levels.

4-6 LIGHT, INTERMEDIATE

There shall be one (1) pair, of Truck-Lite, Model: 60115Y, amber, LED, lights furnished, one (1) each side of the rear fender panel, horizontal, in place of the directional/marker intermediate light. This light shall double as a turn signal and marker light.

4-7 PERIMETER SCENE LIGHTS, CAB

One (1) Amdor Luma Bar H2O LED 20" ground light shall be provided under each side cab door entrance step and under the front bumper, five (5) total. The ground lights at the cab doors shall turn on automatically with each respective door jamb switch, and all lights shall turn on when the parking brake is set, when the transmission is placed in reverse, and all lights to be controlled by a master ground light switch in the cab. The perimeter scene lights shall be wired through the load management system.

Each light shall illuminate an area at a minimum 30" outward from the edge of the vehicle.

4-8 PERIMETER SCENE LIGHTS, BODY

One (1) Amdor Luma Bar H2O LED 20" ground light shall be provided under each side of the body per NFPA compliance. All perimeter lights shall turn on when the parking brake is set, when the transmission is placed in reverse, and all lights to be controlled by a master ground light switch in the cab. The perimeter scene lights shall be wired through the load management system.

Each light shall illuminate an area at a minimum 30" outward from the edge of the vehicle.

4-9 STEP LIGHTS

Chrome plated Whelen model # T0C0ACCR; 2" diameter, LED chassis step lights shall be provided and controlled with marker light actuation. The lights shall be surface mounted using Whelen # TFLANGEC, chrome plated flange. Step lights shall be located to properly illuminate all chassis access steps and walkway areas.

4-10 SCENE LIGHTS

Two (2) **Fire Research Corporation SPECTRA LED Surface Mounts** shall be provided, one on each side of the cab, directly behind the front cab entrance door in a chrome plated flange.

The lights shall be controlled in the following way:

A switch located at the driver's side switch panel

A switch located at the passenger's side switch panel

These lights may be load managed when the parking brake is set.

4-11 CAB SCENE LIGHTS - ADDITIONAL ACTIVATION

In addition to the cab mounted switch for the cab scene lights, the driver and officer cab doors shall activate the respective light when a cab door is opened.

4-12 12 VOLT LIGHTING

There shall be two (2) Whelen Pioneer Model PCP2, 12 volt LED combination spotlight and floodlight(s) provided on the front visor, one (1) on the driver's side and one (1) on the passenger's side.

The lights shall be controlled in the following way:

A switch located at the driver's side switch panel

A switch located at the passenger's side switch panel

These lights may be load managed when the parking brake is applied.

4-13 DECK LIGHTS

Two (2) Hella, Model 74505, rectangular lights shall be mounted; one (1) located each side at the rear of the apparatus body.

The lights shall be activated by a control from a switch at the rear of the truck, with an indicator light and automatically when the truck is placed in reverse.

4-14 GROUND LIGHTS - REAR

One (1) Amdor Luma Bar H2O LED 20" ground light shall be provided under each rear body corner, two (2) total.

One (1) Amdor Luma Bar H2O LED 25" ground light shall be placed under the rear of the body, under the ladder tunnel.

The rear ground lights shall turn on when the parking brake is set, when the transmission is placed in reverse, and all lights to be controlled by a master ground light switch in the cab and wired through the load management system.

4-15 RECESSED 75W PIONEER LED FLOODLIGHTS – REAR

Two (2) Whelen Pioneer model # PFP1 recessed lights shall be installed on rear face of the body, one (1) each side, using the Whelen # PBA103 recessed bracket.

Each lamp head shall have one (1) dual stacked white LED module and shall draw 6 amps and generate 7,000 lumens.

These lights shall be wired to operate in conjunction with the Hella lights described in section 4-13.

4-16 STEP LIGHTS

There shall be three (3) LED step lights provided for each set of aerial turntable access steps.

The step lights shall be actuated by the aerial master switch in the cab.

5-0 COMPARTMENTATION

Compartmentation shall be fabricated of .125" 5052 aluminum. The side compartments are an integral assembly with the rear fenders. Fully enclosed rear wheel housings shall be provided to prevent rust pockets and for ease of maintenance. Due to the severe loading requirements of this aerial, a method of compartment body support suitable for the intended load shall be provided.

The backbone of the support system shall be the chassis frame rail, which is the strongest component of the chassis and is designed for sustaining maximum loads.

A support system shall be used which shall incorporate a floating substructure by using Neoprene Elastomeric isolators to allow the body to remain rigid while the chassis goes through its natural flex. The isolators shall have a broad range of proven viability in vehicular applications, be of a failsafe design, and allow for all necessary movement in three (3) transitional and rotational modes. This shall result in 500 lb equipment rating for each lower compartment of the body.

The compartmentation in front of the rear axle shall include a 3.00" steel support assemblies which are bolted to the chassis frame rails. A steel framework shall be mounted to the body above these support assemblies connected to the support assemblies with isolators. There shall be one (1) support assembly mounted to each chassis frame rail.

The compartmentation behind the rear axle shall include 3.00" steel support assemblies which are bolted to the chassis frame rails and extend underneath to the outside edge of the body. The support assembly shall be

coated to isolate the dissimilar metals before it is bolted to the body. There shall be one (1) support assembly mounted to each chassis frame rail.

A design with body compartments hanging off of the chassis frame in an unsupported fashion shall not be acceptable.

Compartment flooring shall be of the sweep out design with the floor higher than the compartment door lip. The compartment door openings are framed by flanging the edges in 1.75" and bending out again .75" to form an angle. Drip protection is provided over all door openings by means of bright aluminum extrusion or formed bright aluminum tread plate. Side compartment tops shall be covered with bright aluminum tread plate with a 1.00" rolled over edge on the front, rear and outward side. The covers are fabricated in one (1) piece and have the corners welded. A bright aluminum tread plate cover shall be provided on the front wall of each side compartment. All screws and bolts which protrude into a compartment shall have acorn nuts at the ends to prevent injury.

The body design has been fully tested. Proven engineering and test techniques such as finite element analysis, model analysis, stress coating and strain gauging have been performed with special attention given to fatigue life and structural integrity of the compartment body and substructure.

5-1 AGGRESSIVE WALKING SURFACE

All exterior surfaces designated as stepping, standing, and walking areas shall comply with the required average slip resistance of the current NFPA standards.

5-2 LOUVERS

All body compartments shall have a minimum of one (1) set of louvers stamped into a wall to provide the proper airflow inside the compartment and to prevent water from dripping into the compartment. These louvers shall be formed into the metal and not added to the compartment as a separate plate.

5-3 TRANSVERSE COMPARTMENT

A roll-up door compartment shall be installed.

The compartment shall be approximately 54.25" wide x 64.00" high x 24.50" deep in the lower area and transverse in the top portion of the compartment. The transverse area shall be 46.50" wide x 47.00 high.

The door opening shall be approximately 51.25" wide x 56.38" high.

The forward wall shall be notched for the boom support.

One (1) Model 10102 Little Giant folding ladder shall be provided. The stored dimensions shall be 55.00" high x 24.50" wide x 8.00" deep. The weight shall be 35 pounds. This ladder shall be mounted in the transverse compartment.

Two (2) square tubes, 8" x 8" x 53" shall be provided in the transverse compartment for the mounting of two (2) Res-Q-Jacks. Location to be determined at pre-construction conference.

5-4 DRIVER SIDE COMPARTMENTATION

A full height roll-up door compartment, ahead of the rear wheels, shall be approximately 41.75" wide x 64.00" high x 24.25" deep inside with a clear door opening of approximately 38.75" wide x 56.38" high. This

compartment shall be transverse to the passenger side in the top portion of the compartment above the torque box utilizing the maximum area available.

One (1) roll-up door compartment, above the fender (SCBA storage) compartments and over the rear axles, shall be provided. The compartment shall be approximately 72.13" wide x 33.25" high x 24.25" deep inside with a clear door opening of approximately 63.75" wide x 25.50" high.

A compartment with a single pan stainless steel door shall be located above the front stabilizer. The compartment shall be approximately 23.00" high x 18.00" wide x 24.25" deep with a door opening of approximately 15.75" high x 12.00" wide. The door shall be hinged along the top with a spring assisted hinge. Rollers shall be provided along the bottom edge of the compartment and the vertical openings to facilitate the deployment of the electrical cord.

A full height roll-up door compartment, behind the rear wheels, shall be approximately 43.75" wide x 49.25" high x 21.25" deep. The clear door opening shall be approximately 40.75" wide x 41.62" high.

There shall be one (1) compartment, below the turntable, with a roll-up door. The compartment shall be approximately 39.38" wide x 18.38" high x 21.25" deep with a door opening of approximately 33.75" wide x 10.75" high.

5-5 COMPARTMENTATION, PASSENGERS SIDE

A full height roll-up door compartment, ahead of the rear wheels, shall be approximately 41.75" wide x 64.00" high x 24.25" deep inside with a clear door opening of approximately 38.75" wide x 56.38" high. This compartment shall be transverse to the driver side in the top portion of the compartment above the torque box utilizing the maximum area available.

One (1) roll-up door compartment shall be provided above the fender compartments and over the rear axles. The compartment shall be 72.13" wide x 33.25" high x 24.25" deep inside with a clear door opening of 63.75" wide x 25.50" high.

A compartment with a single pan stainless steel door shall be located above the front stabilizer. The compartment shall be 18.00" wide x 23.00" high x 24.25" deep with a door opening of 12.00" wide x 15.75" high. The door shall be hinged along the top with a spring assisted hinge. Rollers shall be provided along the bottom edge of the compartment and the vertical openings to facilitate the deployment of the electrical cord.

A full height roll-up door compartment, behind the rear wheels, shall be 43.75" wide x 49.25" high x 21.25" deep. The clear door opening shall be 40.75" wide x 41.62" high.

There shall be a compartment, below the turntable, with a roll-up door. The compartment shall be 39.38" wide x 18.38" high x 21.25" deep with a door opening of 33.75" wide x 10.75" high.

5-6 ROLL-UP DOOR, SIDE COMPARTMENTS

The roll-up doors shall be Amdor brand roll-up doors. The doors and tracks shall be painted to match the required color of the fire department. Lath sections shall be an interlocking rib design and shall be individually replaceable without complete disassembly of door.

Between each slat at the pivoting joint shall be a PVC inner seal to prevent metal to metal contact and prevent dirt or moisture from entering the compartments. Seals shall allow door to operate in extreme temperatures ranging from plus 180 to minus 40 degrees Fahrenheit. Side, top and bottom seals shall be provided to resist ingress of dirt and weather and be made of Santoprene.

All hinges, barrel clips and end pieces shall be nylon 66. All nylon components shall withstand temperatures from plus 300 to minus 40 degrees Fahrenheit. Hardened plastic shall not be acceptable.

A polished stainless steel lift bar to be provided for each roll-up door. Lift bar shall be located at the bottom of door and have latches on the outer extrusion of the doors frame. A ledge shall be supplied over lift bar for additional area to aid in closing the door.

Doors shall be constructed from an aluminum box section. The exterior surface of each slat shall be flat. The interior surfaces shall be concave to provide strength and prevent loose equipment from jamming the door from inside.

To conserve space in the compartments, the spring roller assembly shall not exceed 3.00" in diameter. A garage style roll door shall not be acceptable.

The header for the roll-up door assembly shall not exceed 4.00".

A heavy-duty magnetic switch shall be used for control of open compartment door warning lights.

5-7 DOOR GUARD

There shall be eight (8) compartment doors that shall include a guard/drip pan designed to protect the roll-up door from damage when in the retracted position and contain any water spray. The guard shall be fabricated from stainless steel and installed each roll up style compartment door.

5-8 REAR BUMPER

A 4.50" stainless steel rear bumper shall be furnished. Bumper shall be highly polished, has radiused ends and reinforcing ribs top and bottom. It shall extend the full width of the body. A 4.00" formed steel channel shall be mounted directly behind the bumper for additional strength.

5-9 COMPARTMENT LIGHTING

Each individual, equipment storage compartment shall be equipped with the AMDOR Luma Bar LED light fixture mounted one each side of the forward (and rear) vertical door frame. The mounting of the light bar(s) shall be mounted firmly to the inside of the compartment. Velcro is not acceptable.

There shall be ten (10) compartments equipped with LED compartment light strips. The strips shall be centered vertically along each side of the door framing. The compartments with these strip lights shall be each equipment compartment.

Any remaining compartments shall include LED lighting to sufficiently illuminate the compartment.

Opening the compartment door shall automatically turn the compartment lighting on.

5-10 MOUNTING TRACKS

There shall be ten (10) sets of tracks for mounting shelves one (1) set in each equipment compartment. These tracks shall be installed vertically to support the adjustable shelves and shall be full height of the compartment. The tracks shall be painted to match the compartment interior.

5-11 ADJUSTABLE SHELVES

There shall be ten (10) shelves with a capacity of 500 pounds provided. The shelf construction shall consist of .188" aluminum with 2.00" sides. Each shelf shall be painted to match the compartment interior. Each shelf shall be infinitely adjustable by means of a threaded fastener, which slides in a track.

The shelves shall be held in place by .12" thick stamped plated brackets and bolts.

The location shall be determined at drawing approval.

5-12 PULL-OUT TRAY

There shall be four (4) slide-out trays with 2.00" sides and a capacity of 500 pounds provided. Capacity rating shall be in the extended position.

Slides shall be General Device ball bearing type for ease of operation and years of dependable service.

Automatic locks shall be provided for both the "in" and "out" positions. The trip mechanism for it shall be located at the front of the tray for ease of use with a gloved hand.

Tray location shall be determined at pre-construction conference.

Heavy-duty steel angle iron assembly shall support the body under the compartment floor. It shall be attached to the chassis frame for load transfer and to reduce stress on body.

5-13 BELOW BODY PULL OUT ALUMINUM TREADPLATE DRAWER

A pullout, underbody drawer, 36" x 36" x 8" will be added to the Officer's side of the apparatus at a location not to interfere with travel or cause damage to the drawer. The location shall be determined at the pre-construction meeting.

5-14 RUB RAIL

The bottom edge of the side compartments shall be trimmed with a poly style rub rail. The rub rail shall be 2.00" high and extend 1.00" away from the body, with slanted ends to provide a pleasing appearance.

These rub rails shall not be an integral part of the body construction, which allows replacement in the event of damage.

5-15 BODY FENDER CROWNS

Stainless steel fender crowns shall be provided around the rear wheel openings.

A rubber welting shall be provided between the body and the crown to seal the seam and restrict moisture from entering.

5-16 AIR CYLINDER STORAGE (Double bottle)

A total of three (3) double air cylinder compartments shall be provided and located with two (2) doubles on the passenger side (one in front of the front axle and one behind the rear axle) and one (1) double on the driver's side (to the rear of the rear axle) of the apparatus body located in the rear fender panels. The area between the front and rear axles shall also contain additional SCBA/fire extinguisher compartments to maximize the use of available space. The tubes shall be of adequate depth to accommodate different size air cylinders and fire

extinguishers. Flooring shall be rubber lined and have a drain hole. A stainless steel door with a chrome-plated latch shall be provided to contain the air bottle. A dielectric barrier shall be provided between the door hinge, hinge fasteners and the body sheet metal.

5-17 TURNTABLE STEPS

Steps to access the turntable from the driver side and passenger side shall be provided just behind the compartmentation.

The steps shall be a swing-down design, with the stepping area made of Morton Tread-Grip® channel.

The step height for the bottom step (the distance from the top surface of the step to the ground) shall not exceed 24.00" with the step in its extended position.

No step height (the distance between the top surfaces of any two (2) adjacent steps) shall be greater than 14.00".

The step well shall be lined with bright aluminum tread plate to act as scuff plates.

The steps shall be connected to the "Do Not Move Truck" indicator.

A handrail shall be provided on each side of the access steps.

5-18 REAR WALL, SMOOTH ALUMINUM

The rear wall shall be smooth aluminum.

5-19 TOW EYES

Two (2) rear painted tow eyes shall be located at the rear of the apparatus and shall be mounted directly to the torque box. The inner and outer edges of the tow eyes shall be radiused.

6-0 LADDERS, STORAGE, PIKE POLES

6-1 EXTENSION LADDER

There shall be two (2) 35', two (2) section aluminum Duo-Safety, Series 1200-A extension ladder provided.

6-2 EXTENSION LADDER

There shall be one (1) 28', two (2) section aluminum Duo-Safety Series 1200A extension ladder provided.

6-3 ROOF LADDER

There shall be two (2) 16' aluminum Duo-Safety Series 875-DR roof ladders provided.

6-4 ADDITIONAL ROOF LADDER

There shall be one (1) 14' aluminum Duo-Safety Series 775-DR provided. With hooks on both ends

6-5 FOLDING LADDER, AERIAL

There shall be one (1) 10' aluminum Duo-Safety Series 585-A folding ladders provided.

6-6 ROOF LADDER (DORMER)

There shall be one 10' aluminum Duo-Safety Series 775-DR roof ladder provided.

6-7 GROUND LADDER STORAGE

The ground ladders are stored within the torque box and are removable from the rear.

Ladders shall be enclosed to prevent road dirt and debris from fouling or damaging the ladders.

The ladders rest in full length stainless steel slides and are arranged in such a manner that any one ladder can be removed without having to move or remove any other ladder.

The rear roll-up door shall be Amdor brand roll-up doors. The door and tracks shall be painted to match the required color of the fire department, to match the rear OR have a satin finish. The latching mechanism shall consist of a full length lift bar lock with latches on the outer extrusion of the door frame.

A stainless plate with a two bend flange and a stainless steel hinge shall be provided to secure the ground ladder complement. The plate assembly shall be mounted to the bottom of the entrance of the torque box ladder storage area.

When the plate is vertical, it shall secure the ladders and prevent them from migrating to the rear of the apparatus. When the plate is down and not securing the ladders, the roll-up door can not close, which shall activate the "Open Door Indicator Light" within the cab. The roll-up door together with hinge friction shall secure the plate in place during driving operations.

A door guard shall be provided to prevent tools inside the torque box from damaging the roll-up door.

6-8 PIKE POLES

There shall be two (2) 12 foot pike poles with fiberglass I-beam handles provided. The pike poles shall be stored in tubular holders located in the ground ladder storage compartment.

6-9 PIKE POLE 8 FT

There shall be two (2) 8 foot pike poles with fiberglass I beam handles provided. The pike poles shall be stored in tubular holders located in the ground ladder storage compartment.

6-10 PIKE POLE 6 FT

There shall be two (2) 6 foot pike poles with fiberglass I beam handles provided. The pike poles shall be stored in tubular holders located in the ground ladder storage compartment.

6-11 PIKE POLE 3 FT

There shall be two (2) 3 foot pike poles with fiberglass shaft and "D" handles shipped loose.

6-12 VELCRO® RETENTION STRAPS

There shall be six (6) Velcro® retention straps threaded through footman loops installed to prevent the pike poles from sliding rearward into the rear access door.

7-0 AUDIBLE WARNING & EMERGENCY RESPONSE LIGHTING

7-1 AIR HORN SYSTEM

Two (2) Grover Stutter Tone 1510 air horns shall be provided and located, in the front bumper, recessed one (1) each side. The horn system shall be piped to the air brake system wet tank utilizing 0.38" tubing. A pressure protection valve shall be installed in-line to prevent the loss of air, in the air brake system.

7-2 AIR HORN CONTROL

The air horns shall be activated by dual lanyards in the cab, one in reach of the driver and one in reach of the officer

7-3 MECHANICAL SIREN

A Federal Q2B siren shall be furnished, pedestal mounted on the driver side of the front bumper as determined at the pre-construction conference.

A siren brake button shall be installed on the cab switch panel.

The control solenoid shall be powered upon activation of the emergency master switch.

The mechanical siren shall be actuated by a foot switch on the officer's side on the right side of the floor in front of the officer's seat and by the horn button in the steering wheel.

The driver shall have the option to control the siren by the horn button. A selector switch to control the chassis horns or the siren from the horn button shall be located on the cab switch panel.

7-4 LIGHTBARS (Cab Roof)

There shall be two (2) 24.00" Whelen, Model FNMINI LED light bars mounted on the cab roof, one (1) on each side, above the driver's and passenger's door, facing forward.

Each light bar shall include the following:

Three (3) red flashing LED modules,

One (1) white flashing LED module.

All the lenses shall be clear.

There shall be one (1) switch, located in the cab, to control these lights.

7-5 WARNING LIGHTS (Cab Face)

Two (2) pair of Whelen Model 60*02F*R LED lights shall be installed on the cab face above the headlights in a two (2) light bezel.

The outer LEDs shall be required for NFPA and shall meet or exceed the NFPA required light output for the front lower zone. The color of these LEDs shall be red Super LED/clea lens.

The inner LEDs shall be additional lighting. The color of these lights shall be red Super LED/clear lens.

Both sets of lights shall be activated by the same switch in the cab.

7-6 SWITCH FOR WHITE WARNING LIGHTS

A single switch shall be provided to control all forward facing white warning lights.

7-7 DAYTIME RUNNING LIGHTS (HEADLIGHTS)

The high-beam headlights used as daytime running lights shall be activated with the following measures:

Ignition switch is turned on.

Parking brake is released.

These lights shall be deactivated with any one of the following measures:

Headlight switch is turned on.

High-beam flash is turned on.

Parking brake is set.

7-8 HEADLIGHT FLASHER

The high beam headlights shall flash alternately between the left and right side, with a control switch located on the cab instrument panel.

The flashing shall automatically cancel when the headlight switch is activated or when the parking brake is set.

7-9 SIDE ZONE LOWER LIGHTING

Six (6) flashing super LED lights shall be located at the following positions:

Two (2) lights one (1) located each side on the front bumper extension - red Super LED/clear lens.

Two (2) lights one (1) located each side on the lower rear corners of the crew cab - red Super LED/clear lens.

Two (2) lights one (1) located each side in the rear fender panels - red Super LED/clear lens.

The lights shall be controlled by a lighted switch on the cab instrument panel.

These lights shall be installed with polished trim flange kits.

7-10 INTERIOR CAB DOOR WARNING LIGHTS

Four (4) Whelen 500 LED flashing lights shall be provided. One (1) light shall be located inside of each cab and crew cab door pan. Each light shall be activated by the door jamb switch of the associated door. The color of the lights shall be amber. The lights shall alternately flash whenever the corresponding door is open and the battery switch is on. These lights shall be mounted in a Whelen trim flange.

7-11 REAR ZONE LOWER LIGHTING

There shall be two (2) Whelen, Model 60*02F*R, LED, red Super LED/clear lens lights located at the rear of the apparatus.

Each light shall be mounted in a Whelen trim flange.

7-12 WARNING LIGHTS

Two (2) Whelen L31H*FN LED warning beacons shall be provided at the rear of the truck, located one (1) each side. These lights shall be activated by a lighted switch on the instrument panel.

The color of the lights shall be red LEDs with both domes clear.

7-13 REAR ARROW STICK

A Whelen Arrow Stick Traffic Advisor LED TACF85 shall be mounted above the ladder tunnel roll up door. The color of the stick shall be amber/yellow in color

Optional to be priced separately:

One Roto-Ray LED rotating warning light....two red and one white light, mounted in the center of the top of the grill.

8-0 ELECTRICAL SYSTEM GENERAL DESIGN for ALTERNATING CURRENT

The following guidelines shall apply to the 120/240 VAC system installation:

8-0-1 General

Any fixed line voltage power source producing alternating current (ac) line voltage shall produce electric power at 60 cycles plus or minus 5 cycles.

Except where superseded by the requirements of NFPA 1901, all components, equipment and installation procedures shall conform to NFPA 70, National Electrical Code (herein referred to as the NEC).

Line voltage electrical system equipment and materials included on the apparatus shall be listed and installed in accordance with the manufacturer's instructions. All products shall be used only in the manner for which they have been listed.

8-0-2 Grounding

Grounding shall be in accordance with Section 250-6 "Portable and Vehicle Mounted Generators" of the NEC. Ungrounded systems shall not be used. Only stranded or braided copper conductors shall be used for grounding and bonding.

An equipment grounding means shall be provided in accordance with Section 250-91 (Grounding Conductor Material) of the NEC.

The grounded current carrying conductor (neutral) shall be insulated from the equipment grounding conductors and from the equipment enclosures and other grounded parts. The neutral conductor shall be colored white or gray in accordance with Section 200-6 (Means of Identifying Grounding Conductors) of the NEC.

In addition to the bonding required for the low voltage return current, each body and driving or crew compartment enclosure shall be bonded to the vehicle frame by a copper conductor. This conductor shall have a minimum amperage rating of 115 percent of the nameplate current rating of the power source specification

label as defined in Section 310-15 (amp capacities) of the NEC. A single conductor properly sized to meet the low voltage and line voltage requirements shall be permitted to be used.

All power source system mechanical and electrical components shall be sized to support the continuous duty nameplate rating of the power source.

8-0-3 Operation

Instructions that provide the operator with the essential power source operating instructions, including the power-up and power-down sequence, along with the power source specification label shall be permanently attached to the apparatus at any point where such operations can take place.

Provisions shall be made for quickly and easily placing the power source into operation. The control shall be marked to indicate when it is correctly positioned for power source operation. Any control device used in the drive train shall be equipped with a means to prevent the unintentional movement of the control device from its set position.

Direct drive (PTO) and portable generator installations shall comply with Article 445 (Generators) of the NEC.

8-0-4 Over current protection

The conductors used in the power supply assembly between the output terminals of the power source and the main over current protection device shall not exceed 144 inches.

For fixed power supplies, all conductors in the power supply assembly shall be type THHW, THW, or use stranded conductors enclosed in nonmetallic liquid tight flexible conduit rated for a minimum of 194 degree Fahrenheit (90 degrees Celsius).

For portable power supplies, conductors located between the power source and the line side of the main over current protection device shall be type SO or type SEO with suffix WA flexible cord rated for 600-volts at 194 degrees Fahrenheit (90 degrees Celsius).

8-0-5 Wiring Methods

Fixed wiring systems shall be limited to the following:

- Metallic or nonmetallic liquid tight flexible conduit rated at not less than 194 degrees Fahrenheit (90 degrees Celsius)
- Type SO or Type SEO cord with a WA suffix, rated at 600 volts at not less than 194 degrees Fahrenheit (90 degrees Celsius)

Electrical cord or conduit shall not be attached to chassis suspension components, water or fuel lines, air or air brake lines, fire pump piping, hydraulic lines, exhaust system components, or low voltage wiring. In addition the wiring shall be run as follows.

- Separated by a minimum of 12 inches (305 mm), or properly shielded, from exhaust piping
- Separated from fuel lines by a minimum of six (6) inches (152 mm) distance.

Electrical cord or conduit shall be supported within six (6) inches (152 mm) of any junction box and at a minimum of every 24 inches (610 mm) of continuous run. Supports shall be made of nonmetallic materials or corrosion protected metal. All supports shall be of a design that does not cut or abrade the conduit or cable and shall be mechanically fastened to the vehicle.

8-0-6 Wiring Identification

All line voltage conductors located in the main panel board shall be individually and permanently identified. The identification shall reference the wiring schematic or indicate the final termination point.

8-0-7 Wet Locations

All wet location receptacle outlets and inlet devices, including those on hardwired remote power distribution boxes, shall be of the grounding type provided with a wet location cover and installed in accordance with Section 210-7 "Receptacles and Cord Connections" of the NEC.

All receptacles located in a wet location shall be not less than 24 inches (610 mm) from the ground. Receptacles on off-road vehicles shall be a minimum of 30 inches (762 mm) from the ground.

The face of any wet location receptacle shall be installed in a plane from vertical to not more than 45 degrees off vertical. No receptacle shall be installed in a face up position.

8-0-8 Dry Locations

All receptacles located in a dry location shall be of the grounding type. Receptacles shall be not less than 30 inches above the interior floor height.

All receptacles shall be marked with the type of line voltage (120-volts or 240-volts) and the current rating in amps. If the receptacles are direct current, or other than single phase, they shall be so marked.

8-0-9 Listing

All receptacles and electrical inlet devices shall be listed to UL 498, Standard for Safety Attachment Plugs and Receptacles, or other appropriate performance standards. Receptacles used for direct current voltages shall be rated for the appropriate service.

8-0-10 Electrical System Testing

The wiring and associated equipment shall be tested by the apparatus manufacturer or the installer of the line voltage system.

The wiring and permanently connected devices and equipment shall be subjected to a dielectric voltage withstand test of 900-volts for one (1) minute. The test shall be conducted between live parts and the neutral conductor, and between live parts and the vehicle frame with any switches in the circuit(s) closed. This test shall be conducted after all body work has been completed.

Electrical polarity verification shall be made of all permanently wired equipment and receptacles to determine that connections have been properly made.

8-0-11 Operational Test per Current NFPA 1901 Standard

The apparatus manufacturer shall perform the following operation test and ensure that the power source and any devices that are attached to the line voltage electrical system are properly connected and in working order. The test shall be witnessed and the results certified by Underwriters Laboratories.

The prime mover shall be started from a cold start condition and the line voltage electrical system loaded to 100 percent of the nameplate rating.

The power source shall be operated at 100 percent of its nameplate voltage for a minimum of two (2) hours unless the system meets category certification as defined in the current NFPA 1901 standard.

Where the line voltage power is derived from the vehicle's low voltage system, the minimum continuous electrical load as defined in the current NFPA 1901 standard shall be applied to the low voltage electrical system during the operational test.

9-0 GENERATOR

The apparatus shall be equipped with a complete electrical power system.

The generator shall be one (1) Harrison MPC Hydraulic Driven Generator rated at 10,000 watts, 42/84 amps, 120/240 VAC, 60Hz, 1-phase.

The generator shall use a cover consisting of NFPA approved diamond tread plate

The output of the generator shall be controlled by an internal hydraulic system. An electrical instrument gauge panel shall be provided for the operator to monitor and control all electrical operations and output.

The generator shall be driven by an engine transmission power take off unit, through a hydraulic pump and motor. The hydraulic engagement supply shall be operational only after the chassis parking brake is applied.

An electric/hydraulic valve shall supply hydraulic fluid to the clutch engagement unit provided on the chassis PTO drive.

The generator hydraulic circuit shall include a soft start valve to protect the generator components during PTO engagement.

9-1 Generator Instruments and Controls

To properly monitor the generator performance a digital meter panel shall be furnished and mounted next to the circuit breaker panel. The meter shall indicate the following items:

- Voltage
- Amperage for both lines
- Frequency
- Generator run hours
- Over current indication
- Over temperature indication
- Service required indication
- "PTO" engagement indication
- "Power On" indication
- Two (2) fuse holders with two (2) amp fuses (for indicator light protection)

The meter and indicators shall be installed near eye level in the compartment. Instruments shall be flush mounted in an appropriate sized weatherproof electrical enclosure. All instruments used shall be accurate within +/- Two (2) percent.

9-2 Generator Wiring

The system shall be installed by highly qualified electrical technicians to assure the required level of safety and protection to the fire apparatus operators. The wiring, electrical fixtures and components shall be to the highest industry quality standards available on the domestic market. The equipment shall be the type as designed for mobile type installations subject to vibration, moisture and severe continuous usage. The following electrical components shall be the minimum acceptable quality standards for this apparatus.

9-3 Wiring

All electrical wiring shall be fine stranded copper type. The wire shall be sized to the load and circuit breaker rating; ten (10) gauge on 30 amp circuits, 12 gauge on 20 amp circuits and 14 gauge on 15 amp circuits. The cable shall be run in corner areas and extruded aluminum pathways built into the body for easy access.

9-4 LOAD CENTER

The main load center shall be a Cutler Hammer with circuit breakers rated to load demand.

9-5 Circuit Breakers

Individual breakers shall be provided for all on-line equipment to isolate a tripped breaker from affecting any other on-line equipment.

9-6 GENERATOR LOCATION

The generator shall be permanently mounted above the torque box.

9-7 GENERATOR START

A switch shall be located on the cab instrument panel to engage the generator.

9-8 CIRCUIT BREAKER PANEL

The location of the panel shall be determined at the pre-construction conference.

9-9 GROUND FAULT CIRCUIT INTERRUPTER

The specified 120 volt option the AC breaker box with the features selected at drawing approval shall be supplied with a ground fault circuit interrupter (GFCI) circuit breaker.

The total quantity shall be ten (10) circuit breakers.

The GFCI breakers shall only be used in the branch circuits and shall not be used as a "master" circuit breaker.

9-10 240 VOLT LIGHTING

The apparatus shall be equipped with 4 non-telescoping Fire Research Focus Model SPA100 LED floodlights. Each light head shall be 240 volt, 1000 watts, with a 4.2 amp draw. The light head shall swivel 360 degrees left or right and tilt up and down.

A total of four (4) shall be provided; two (2) located each side of the apparatus body on top of the catwalk with the final location determined at the pre-construction conference.

9-11 ELECTRIC CORD REELS (2)

Furnished with the 120-volt AC electrical system shall be two (2) electric cord reels. The reels shall be provided with a 12-volt electric rewind switch, that is guarded to prevent accidental operation and labeled for its intended use. The switch shall be protected with a fuse and installed near the reel.

A captive roller assembly shall be provided to aid in the payout and loading of the reel. A ball stop shall be provided to prevent the cord from being wound on the reel.

A label shall be provided in a readily visible location adjacent to the reel. The label shall indicate current rating, current type, phase, voltage and total cable length.

The reel capacity shall be 200 ft of 10/3 cable.

Provided for electric distribution shall be two (2) lengths, one (1) for each reel, of 200 feet of yellow 10/3 electrical cord, weather resistant 105 degree C to -50 degree C, 600 volt jacketed SOOW cord. No connector shall be installed on the end of the cord.

Both reels shall be mounted in the cargo storage area behind the compartment over the forward stabilizer. The reel shall be covered by an aluminum tread plate box that can be removed to service the reel. The cord shall feed through the rear wall of the compartment above the forward stabilizer.

9-12 PORTABLE JUNCTION BOX

Two (2) Akron EJBX junction boxes shall be provided.

Each junction box shall have three (3)-120 volt AC, 20 amp twist lock receptacles and one (1)-120 volt AC, 20 amp straight blade duplex (household) receptacle provided in a portable junction box. The junction box shall be of weatherproof construction and have flip up lids lined with soft neoprene rubber at each outlet opening.

The junction box shall be connected to the cord on the reel with a twist lock connector body.

9-13 20 AMP RECEPTACLE

Wired to the power supply shall be two (2) receptacles that are 120 volt 20 amp three wire twist-lock NEMA L5-20 type with weather resisting cover with the locations on the apparatus body to be determined at the pre-construction conference.

10-0 FOUR (4)-SECTION 100 FOOT (Minimum) AERIAL LADDER

10-1 CONSTRUCTION STANDARDS

The ladder shall be constructed to meet all of the requirements as described in the current NFPA 1901 standards.

The aerial device shall be a true ladder type device; therefore ladders attached to booms shall not be considered.

These capabilities shall be established in an unsupported configuration.

All structural load supporting elements of the aerial device that are made of a ductile material shall have a design stress of not more than 50% of the minimum yield strength of the material based on the combination of the live load and the dead load. This 2:1 structural safety factor meets the current NFPA 1901 standard.

All structural load supporting elements of the aerial device that are made of non-ductile material shall have a design stress of not more than 20% of the minimum ultimate strength of the material, based on the combination of the rated capacity and the dead load. This 5:1 safety factor meets the current NFPA 1901 standard.

Wire ropes and attaching systems used to extend and retract the fly sections shall have a 5:1 safety factor based on the ultimate strength under all operating conditions. The factor of safety for the wire rope shall remain above 2:1 during any extension or retraction stall. The minimum ratio of the diameter of wire rope used to the diameter of the sheave used shall be 1:12. Wire ropes shall be constructed of seven (7) strands over an inner wire core for increased flexibility. The wire rope shall be galvanized to reduce corrosion.

The aerial base pivot bearings shall be maintenance free type bearings and require no external lubrication.

The aerial device shall be capable of sustaining a static load one and one-half times its rated tip load capacity (live load) in every position in which the aerial device can be placed when the vehicle is on a firm level surface.

The aerial device shall be capable of sustaining a static load one and one-third times its rated tip load capacity (live load) in every position the aerial device can be placed when the vehicle is on a slope of five degrees downward in the direction most likely to cause overturning.

With the aerial device out of the cradle in the in the fully extended position at zero degrees elevation, a test load shall be applied in a horizontal direction normal to the centerline of the ladder. The turntable shall not rotate and the ladder shall not deflect beyond what the product specification allows.

All welding of aerial components, including the aerial ladder sections, turntable, pedestal, and outriggers, shall be in compliance with the American Welding Society standards. All welding personnel shall be certified, as qualified under AWS welding codes.

The aerial device shall be capable of operating with the maximum rated tip load in either of the two (2) following conditions:

- Conditions of high wind up to 50 mph
- Conditions of icing, up to a coating of .25" over the entire aerial structure

All of the design criteria must be supported by the following test data: (no exception)

- Strain gage testing of the complete aerial device
- Analysis of deflection data taken while the aerial device was under test load

The following standards for materials are to be used in the design of the aerial device:

- Materials are to be certified by the mill that manufactured the material
- Materials that are certified or recertified by vendors other than the mill shall not be acceptable
- Material testing that is performed after the mill test shall be for verification only and not with the intent of changing the classification

- All welded structural components for the ladder shall be traceable to their mill lots.

10-2 LADDER CONSTRUCTION

The ladder shall be comprised of four sections.

The ladder shall have the capability to support a minimum of 750 pounds at the tip in the unsupported configuration, based upon 360 degree rotation, up to full extension and from a minimum of -6 degrees to a minimum of +72 degrees.

The ladder (handrails, base rails, trusses, K-braces and rungs) shall be constructed of high strength low alloy steel, minimum 70,000 pounds per square inch yield, with full traceability on all structural members.

Each section shall be trussed diagonally, vertically and horizontally using welded steel tubing.

All ladder rungs shall be round and welded to each section utilizing "K" bracing for torsional rigidity.

The inside width dimensions of the ladder shall be a minimum of:

- Base Section 39.00"
- Inner-Mid Section 32.25"
- Outer-Mid Section 26.62"
- Fly Section 21.62"

The height of the handrails above the centerline of the rungs shall be a minimum of:

- Base Section 26.75"
- Inner-Mid Section 22.87"
- Outer-Mid Section 20.25"
- Fly Section 17.375"

The ladder shall be designed to provide continuous egress for firefighters and civilians from an elevated position to the ground. The end of the fly section shall be constructed in a manner that aids personnel who are climbing off the ladder.

There shall be a removable egress section at the tip of the ladder. The egress section shall be designed to maintain the rated load of the aerial device. It shall be bolted on for easy replacement.

10-3 VERTICAL HEIGHT

The ladder shall extend to a minimum height of 100' above the ground at full extension and elevation. The measurement of height shall be consistent with NFPA standards.

10-4 HORIZONTAL REACH

The rated horizontal reach shall be a minimum of 100'. (No exception). The measurement of horizontal reach shall be consistent with NFPA standards.

10-5 TURNTABLE

The upper turntable assembly shall connect the aerial ladder to the turntable bearing. The steel structure shall have a mounting position for the aerial elevation cylinders, ladder connecting pins, and upper turntable operator's position.

The stepping surfaces and walking areas shall meet the skid-resistance requirements of the current NFPA 1901 standard.

The turntable platform shall be a minimum of 95.00" wide x 84.50" long.

The turntable shall be lit to meet current NFPA 1901 requirements. Lights shall be activated by the aerial master switch.

The turntable handrails shall be a minimum 42.00" high and shall not increase the overall travel height of the vehicle. The handrails shall be constructed from aluminum or stainless steel and have a slip resistant surface.

Man Saver™ bars shall be installed at the aerial turntable.

10-6 ELEVATION SYSTEM

Two (2) double acting lift cylinders shall be utilized to provide smooth precise elevation from a minimum of 6 degrees below horizontal to a minimum of 72 degrees above horizontal.

The lift cylinders shall be equipped with integral holding valves located on the cylinder to prevent the unit from falling should the charged lines be severed at any point within the hydraulic system.

Ladder tip speed shall be automatically decelerated when the angle is near maximum elevation reducing tip-lash.

10-7 EXTENSION/RETRACTION SYSTEM

A full hydraulic powered extension and retraction system shall be provided using two (2) hydraulic cylinders and wire ropes.

Each cylinder shall be capable of operating the ladder in the event of a failure of the other.

Extension and retraction shall be internally limited within the cylinders, eliminating excess strain on wire ropes, sheaves and the ladder structure.

Each of the cylinders, wire ropes and sheave assemblies shall be completely independent of the other, so as to provide a safety factor wherein a failure of one assembly shall not affect the function and operation of the other.

The extension cylinders shall be equipped with integral holding valves to prevent the unit from retracting should the charged lines be severed at any point within the hydraulic system.

The cylinders shall also have internal deceleration valves to cushion the movement of the cylinder when approaching full extension or retraction.

The reeling of the wire rope shall be such as to provide synchronized, simultaneous movement of all sections to full extension.

Wear pads shall be used between the telescoping sections for maximum weight distribution, strength and smoothness of operation.

Wear pads shall be adjustable to permit proper side alignment.

All sheaves shall be greaseless and all sheave pins and pivot pins shall be polished stainless steel. (No Exception)

10-8 ROTATION SYSTEM

The bearing shall provide 360 degree continuous rotation.

The turntable base and the torque box bearing plate shall be machined flat thereby providing even distribution of forces.

Two hydraulically driven planetary gear boxes will be used to provide infinite and minute rotation control throughout the entire rotational travel.

Each planetary gearbox will have a spring applied, hydraulically released disc type swing brake to provide positive braking of the turntable assembly.

10-9 ROTATION INTERLOCK

A permanently installed prevention mechanism shall be provided as part of the rotation system to prevent the rotation of the aerial device to the side in which the stabilizers have not been fully deployed or are short-jacked.

The mechanism shall allow full and unrestricted use of the aerial on the side(s) where the stabilizers have been fully deployed.

The system shall also have a manual override to comply with NFPA 1901.

Systems that permit the aerial to rotate to the short jack side without automatically stopping the rotation and/or without actuation of the manual override shall not be accepted. Systems that only include an alarm are not considered an interlock and shall not be accepted.

10-10 LOADMINDER

A Class 1 Loadminder shall be installed on the aerial turntable control pedestal that calculates and displays the current low level load of the aerial with an LED display that instantly adjusts as the ladder angle, extension or live load changes. When the maximum low-level loading approaches the display will begin to flash. A slight (50 – 100 lbs) additional load will cause the audible and visual alarms to sound which will alert an operator to an overload condition.

The Loadminder shall be installed with 2 amber LED warning lights that will flash when the unit indicates overload conditions. The lights shall be located on either side near the front of the base aerial section.

10-11 COLLISION AVOIDANCE

The aerial device shall be supplied with a collision avoidance control system. The collision avoidance control system shall be calibrated so that the aerial device does not make contact with any part of the fire apparatus during normal operation.

The aerial ladder shall be equipped with an absolute encoder for position and direction reference. The absolute encoder shall provide an absolute position of the turntable for all 360 degrees of rotation.

If the power is interrupted for any reason, the absolute encoder shall allow power to be returned to the system without having to re-zero the settings.

The collision avoidance control system shall be equipped with a warning system that alerts the operator when the aerial device has reached the limits of each control zone. The warning system shall sound when either the rotation or elevation movements reach the limits of the control zone.

10-12 TORQUE BOX

A "torsion box" sub frame shall be installed between the two (2) sets of stabilizers.

The torque box sub frame assembly shall be capable of withstanding all torsional and horizontal loads when the unit is on the stabilizers.

10-13 LOAD CAPACITIES

A load chart, visible at the operator's station, shall be provided. The load chart shall show the recommended safe load at any condition of the aerial device's elevation and extension. (No Exception)

10-14 BOOM SUPPORT

A heavy duty boom support shall be provided for support of the ladder in the travel position. On the base section of the ladder, a stainless steel scuff plate shall be provided where the ladder comes into contact with the boom support.

The boom support shall be located just to the rear of the chassis cab, recessed into the transverse compartment in place of pump.

10-15 AERIAL SIGN PANEL FOR LETTERING

There shall be one sign panel provided on each side of the aerial ladder base section. The sign panel shall be painted to match apparatus paint color.

The sign panels shall be designed so no mounting bolts are in the face of the panel. This shall keep the lettering surface free of holes.

10-16 EXTENSION INDICATOR

Extension markings and corresponding numerical indicators shall be provided along each inside and outside top rail of the base section of the aerial every ten (10) feet. They shall indicate various positions of extension up to full. Markings and indicators shall be clearly visible to the console operator. To aid in visibility during hours of darkness, the markings and numerical indicators shall be of a red reflective material.

10-17 FOLDING STEPS

One (1) set of folding steps shall be provided at the tip of the ladder. The steps shall fold into proper position for usage and fold toward the sides of the ladder when not in use to provide adequate clearance when the ladder is being climbed. The steps shall be placed approximately 70" from the center of the last rung toward the base of the aerial.

10-18 AERIAL DEVICE RUNG COVERS

Each rung shall be covered with a secure, heavy-duty, fiberglass pultrusion that incorporates an aggressive, no-slip coating.

The rung covers shall be glued to each rung, and shall be easily replaceable should the rung cover become damaged. Under no circumstances shall the rung covers be fastened to the rungs using screws or rivets (No Exception.)

A portion of each rung cover shall be photo/luminescent to assist in providing a light source for each rung during low light conditions and the remainder shall be black.

The rung covers shall have a 10-year, limited

10-19 LADDER STORAGE MOUNTING BRACKETS

Mounting shall be provided on the left side of the aerial device while viewed from the turntable for storage of one (1) roof ladder. The brackets shall be located inboard of the sign panel at the base section. The mounting brackets shall accommodate a 14' Duo-Safety 775-A roof ladder.

This equipment shall not impact the 750# tip load rating of the aerial device.

Mounting shall be provided on the right side of the aerial device while viewed from the turntable for storage of one (1) dormer ladder. The brackets shall be located inboard of the sign panel at the base section. The mounting brackets shall accommodate a 10' Duo-Safety 775-DR roof ladder.

Mounting shall be provided near the end of the fly section of the aerial ladder for one (1) ten (10) foot folding ladder.

This equipment shall not impact the 750# tip load rating of the aerial device.

10-20 PIKE POLE MOUNTING BRACKETS

Mounting shall be provided near the end of the fly section of the aerial ladder for one (1) pike pole.

The bracket shall be sized to hold an Akron 12' pike pole.

This equipment shall not impact the 750# tip load rating of the aerial device.

10-21 AXE MOUNTING BRACKETS

Mounting shall be provided near the end of the fly section of the aerial ladder for one (1) 6# pick head axe.

This equipment shall not impact the 750# tip load rating of the aerial device.

10-22 STORAGE BOX AT TURNTABLE

A storage box with a hinged cover shall be provided at the turntable. The box and cover shall be constructed of aluminum tread plate.

10-23 TURNTABLE CONTROL STATION

There shall be a turntable control station located on the left hand side of the turntable so the operator shall be able to easily observe the ladder tip while operating the controls. The controls shall permit the operator to regulate the speed of the aerial functions within safe limits (as determined by the manufacturer and NFPA

standards). The controls shall be clearly marked and lighted for nighttime operation. A hinged cover shall be provided. Ladder controls shall be capable of being operated independently or simultaneously.

The following controls and indicator lights shall be clearly identified, illuminated, and conveniently located for ease of operation and viewing:

- Elevation, extension/retraction, and rotation controls
- High idle switch
- Rung alignment indicator light
- Tip/Tracking lights switch
- Hydraulic system pressure gauge
- Indicator/Alarm test switch
- EPU switch and light
- Operator's load chart
- Stabilizer Not Fully Extended indicator light
- Monitor controls
- Aerial waterway flow meter
- Loadminder display

There shall also be a minimum of two (2) 12-volt LED work lights installed on the turntable to illuminate the surrounding area for nighttime operation. The work lights shall be activated by the aerial master switch.

10-24 REMOTE AERIAL CONTROL

A remote control shall be provided whereby all ladder movements can be controlled at the ladder tip in addition to the control console.

The three (3) ladder functions (extension, rotation, and elevation) shall be controlled individually by means of spring loaded, return to center 12-volt proportional controls.

A switch at the turntable control station shall activate the controls at the ladder tip.

The remote control aerial speed shall be set in accordance with the current NFPA 1901 standards.

10-25 STABILIZERS

The vehicle shall come equipped with a stabilization system consisting of four (4) hydraulically operated out and down style stabilizers. This system shall meet or exceed all requirements of the NFPA specifications related to stabilization and setup on sloped surfaces.

The stabilizer/leveling jacks shall have a maximum spread of 16' measured from the centerline of the jack footpads when the beams are fully extended. The cylinders shall have pilot-operated check valves with thermal relief designed to insure that the beams shall not drift out of the stowed position during travel. Wear pads shall guide the stabilizers.

The horizontal extension cylinders shall be totally enclosed within the beams and shall incorporate telescoping hydraulic tubing to supply the jack cylinder hydraulic power. Stabilizer hydraulic hoses shall remain stationary during operation of the stabilizers to prevent hose wear and potential failure. The cylinders shall be equipped with decelerators to reduce the speed of extension and retraction when the beams are near the fully retracted and extended positions.

The cylinders shall be supplied with pilot operated check valves on each jack cylinder to hold the cylinder in the stowed or working position, should a charged line be severed at any point in the hydraulic system. Vertical jack cylinder rods shall be fully enclosed by a telescoping inner box to protect the cylinder rods from damage.

Each stabilizer shall have a cover painted red to match the color of the body and cab. This plate shall serve as a protective guard and a mounting surface for warning lights. The top, forward, and rear edges shall be flanged back 90 degrees for added strength. A clear work light shall be provided to illuminate the stabilizer and the ground. Lighting shall automatically activate with the aerial master switch.

10-26 STABILIZER PADS

The footpad shall be attached to the jack cylinder rod by means of a machined ball at the end of the jack cylinder rod which mates to a socket machined into the footpad or equivalent. The footpad shall have the ability to pivot in any direction to allow setup on uneven terrain.

10-27 AUXILIARY STABILIZER PADS

An auxiliary ground pad shall be supplied for each stabilizer to provide additional load distribution on soft surfaces. The pads shall be made from a lightweight composite material or aluminum. The ground pressure shall not exceed 75 pounds per square inch when the ground pads are used and the apparatus is fully loaded and the aerial device is carrying its rated capacity in any position. Each pad shall be stored individually as close as possible to each stabilizer.

10-28 STABILIZER CONTROLS

An electrically controlled hydraulic valve shall power stabilizer movement. The valve can also be manually controlled in the event of electrical malfunction. Hydraulic power override controls shall be incorporated into the valve. The manual override mechanism shall be completely sealed within the valve assembly to prevent any possibility of corrosion.

The stabilizer controls shall be located to provide the operator with a full view of each stabilizer being positioned. Each stabilizer control panel shall include the following:

- In/out stabilizer beam control switch or valve
- Up/down stabilizer jack control switch or valve
- Emergency hydraulic power unit (EPU) control switch
- High idle control switch
- Stabilizer fully extended LED indicator lights
- Stabilizer firm on ground LED indicator lights

Each stabilizer control panel shall be covered with a stainless steel door that protects against road grime and corrosion.

As a safety device, an electrically actuated diverter valve shall be provided. The hydraulic power shall be diverted to the aerial ladder controls automatically the instant all stabilizer jacks are firmly planted on the ground. Once the aerial ladder is raised from the bedded position, the stabilizer hydraulic power is cut off so the stabilizers shall not accidentally be moved while the aerial is being operated.

To aid in leveling the unit, two bubble type angle indicators shall be located near the stabilizer controls. One indicator shall show the angle of the truck from the front to rear and the other shall show the side to side angle of the truck. The indicators shall be color coded green to show when the truck has been properly leveled allowing the aerial device to be operated at full capacity and yellow if the aerial device may be used in a reduced capacity.

A stabilizer deployment audible warning alarm shall be provided at each side of the body, activated by the stabilizer movement.

10-29 SPLASH GUARD FOR REAR CONTROLS

A splash guard shall be provided to protect the stabilizer controls from road splash and grime.

10-30 STABILIZER PINS

The stabilizer jacks may have holes for stabilizer pins if required by the manufacturer.

10-31 HYDRAULIC SYSTEM

All manufacturing employees responsible for the installation of hydraulic components shall be properly trained. Training shall include: proper handling, installation, torque requirements, cleanliness and quality control procedures for hydraulic components.

Hoses used in the aerial hydraulic system shall be of a premium quality hose with a high abrasion resistant cover. All pressure hoses shall have a working pressure of 4000 psi. and a burst pressure rating of 16,000 psi.

The hydraulic oil shall have maximum anti-wear properties. Each aerial shall be evaluated as to the region and climate where it shall be used to determine the optimum viscosity and proper oil grade. Oil viscosity shall be based on an optimum range of 80 to 1000 SUS during normal aerial use. Before shipment of the unit, an oil sample shall be taken and analyzed to confirm the oil is within the allowable ISO grade tolerance.

The aerial hydraulic system shall have a minimum oil cleanliness level of ISO 18/15/13 based on the ISO 4406:1999 cleanliness standard. Each customer shall receive a certificate of actual cleanliness test results and an explanation of the rating system.

Each aerial shall include an oil sample port, identified with a yellow dust cap and a label, for subsequent customer testing.

Ball valves shall be provided in the hydraulic suction and return lines to permit component servicing without draining the oil reservoir.

The system hydraulic pressure shall be displayed on the turn table control console.

The hydraulic system shall be additionally protected from excessive pressure by a secondary pressure relief valve. In the event the main hydraulic pump compensator malfunctions, the secondary relief shall prevent system damage.

10-32 HYDRAULIC CYLINDERS

All cylinders used on the aerial device shall be produced by a manufacturer that specializes in the manufacture of hydraulic cylinders.

Each cylinder shall include integral safety holding cartridges. No manifold or transfer tube mounted cartridges shall be acceptable.

Each cylinder shall be designed to a minimum safety factor of 4:1 to failure.

All safety holding cartridges shall be installed at the cylinder manufacturer, in a controlled clean environment to avoid possible contamination and or failure.

10-33 HYDRAULIC PUMP

The hydraulic system shall be supplied by a load and pressure compensating pump. The pump shall meet the demands of all three (3) simultaneous aerial functions. The pump shall provide proper flow for a single aerial function with the engine at idle speed. A switch shall be provided on the control console to increase the engine speed for multiple function operation.

10-34 EMERGENCY PUMP

The aerial shall be equipped with an emergency hydraulic pump, electrically driven from the truck batteries. The pump shall be capable of limited aerial functions to stow the unit in case of a main pump or truck system failure. A momentary switch shall be located at the stabilizer and aerial control locations to activate the emergency pump.

10-35 AERIAL CONTROL VALVE

The aerial hydraulic control valve shall be designed with special spool flows, limiting the oil flow for the designed function speed. The valve shall be manually controlled and be located in the control console with the handles protruding through the operating surface for operation. The activation handles shall be spaced a minimum of 3.5" for ease of operation.

10-36 OIL RESERVOIR

The oil reservoir shall have a minimum capacity as determined by the manufacturer to extend all the hydraulic components of the system to their maximum range. The oil fill location shall be easily accessible and be labeled "Hydraulic Oil Only" and also indicate the grade of oil that is installed in the reservoir. A drain hose shall be included and shall terminate with a quarter turn ball valve. Two (2) suction ports shall be provided, one (1) for the main hydraulic pump and one (1) for the emergency pump. The main suction shall be slightly elevated off the bottom of the reservoir and include a 100 mesh suction strainer. A magnetic drain shall also be provided to collect any ferrous contaminants. A float type sending unit in the reservoir shall provide an indication of oil level on an electric gauge mounted adjacent to the fill location.

The reservoir tank shall be mounted in such a manner as to prevent the development of leaks caused by twisting or straining when the apparatus operates over uneven ground. The tank assembly shall be isolated from the chassis frame rails with rubber isolators.

10-37 HIGH PRESSURE FILTER

The pressure filter shall be rated for 6,000 psi working pressure and generously sized for efficiency and capacity. A 90 psi bypass spring shall be included to protect the element and hydraulic system during lower than normal system operating temperatures.

The 5Q filter element shall be constructed of a micro glass medium, which has the highest capture efficiency, dirt holding capacity and life expectancy over other media such as cellulose and synthetic. The nominal rating shall be 5 micron and have an efficiency rating of 99.3 % for 5 micron sized particles. The element shall have a dirt holding capacity of not less than 35 grams.

10-38 RETURN FILTER

The return filter shall be rated for 800 psi working pressure and generously sized for efficiency and capacity. A 25 psi bypass spring shall be included to protect the element and hydraulic system during lower than normal system operating temperatures. The 5Q filter element shall be constructed of a micro glass medium, which has the highest capture efficiency, dirt holding capacity and life expectancy over other media such as cellulose and synthetic. The nominal rating shall be 5 microns and have an efficiency rating of 99.6% for 5 micron sized particles. The element shall have a dirt holding capacity of not less than 40 grams.

10-39 HYDRAULIC SWIVEL

The aerial ladder shall be equipped with a high pressure hydraulic swivel which shall connect the hydraulic lines from the hydraulic pump and reservoir, through the rotation point, to the aerial control bank. The hydraulic swivel shall allow for 360-degree continuous rotation of the aerial.

10-40 ELECTRIC SWIVEL

The ladder shall be equipped with an electric swivel to allow 360-degree rotation of the aerial while maintaining connections in all electrical circuits through the rotation point. The collector rings shall be used for electrical ground, ladder control functions, and a 120 volt A.C. system during 360 degrees of continuous turntable rotation. The collector ring assembly shall have a minimum of 28 circuits capable of supplying 30-amp continuous service shall be provided. All collector rings shall be enclosed and protected against condensation and corrosion. (No Exception).

10-41 ELECTRICAL SYSTEM

The aerial electrical system shall be designed and manufactured in such a way that the power and signal protection and control compartments shall contain circuit protection devices and power control devices. The power and signal protection and control components shall be protected against corrosion, excessive heat, excessive vibration, physical damage, and water spray.

The aerial electrical system shall be designed and manufactured to allow the following:

- All of the serviceable components shall be readily accessible.
- Circuit protection devices shall be utilized to protect each circuit.
- All circuit protection devices shall be sized to prevent wire and component damage when subjected to extreme current overload.

- General protection circuit breakers shall be Type-I automatic reset (continuously resetting) or Type-II (manual resetting) and conform to SAE requirements. When required, automotive type fuses conforming to SAE requirements shall be utilized to protect electronic equipment.
- Power control relays and solenoids, when utilized, shall have a direct current (dc) rating of 125% of the maximum current for which the circuit is protected.

The aerial electrical system shall be designed and manufactured to allow the following:

- Toggle switches shall be utilized that are certified for the outside conditions that fire apparatus experience.
- All wiring shall be protected through conduit or loom.
- All wiring harnesses shall be properly supported to eliminate harness damage through rubbing.
- A switch and illumination light shall be incorporated into the boom support.
- Standard cabling to the tip of the aerial shall consist of one (1) 16/20 cable and one (1) 12/8 cable.

10-42 DRIVER SIDE TORQUE BOX POWER DISTRIBUTION PANEL

A fuse and relay panel, located for ease of access, shall include the following:

- NEMA 4x rated weatherproof enclosure
- Relays, fuses, and circuit breakers for aerial and stabilizer interlocks and control switches

10-43 TURNTABLE LIGHTING

The turntable shall be lighted for nighttime operation with a minimum of two (2) LED work lights activated by the aerial master switch.

10-44 AERIAL FOOT SWITCH

A foot switch shall be located at the turntable console to allow hydraulic flow to the aerial device. The foot switch shall be protected by a cover to prevent accidental activation. Activation of the foot switch is necessary for aerial device operation.

10-45 TURNTABLE OVERRIDE CONTROLS

The aerial manual override controls shall be located in the turntable control console.

10-46 MASTER OVERRIDE CONTROLS

An emergency power switch shall be located at the rear of the apparatus. The switch shall activate the emergency power unit and allow control of the aerial or stabilizers.

A LED work light shall be provided to illuminate the master override controls when the battery switch is active and the master override door is open.

10-47 BOOM SUPPORT

A switch shall be provided on the boom support to detect if the aerial device is fully stowed within the boom support.

10-48 STABILIZER INDICATOR

A "Stabilizers Not Stowed" indicator shall be provided in the driver's compartment. It shall illuminate automatically whenever the stabilizers are not fully stowed, to prevent damage to the apparatus if moved. The stabilizer system shall also be wired to the "Do Not Move" indicator light, which shall flash whenever the apparatus parking brake is not fully engaged and the stabilizers are not fully stowed. An equivalent system that meets the intent of this paragraph shall also be acceptable.

10-49 CRADLE INTERLOCK SYSTEM

A cradle interlock system shall be provided to prevent the lifting of the aerial from the nested position until the operator has positioned all the stabilizers in a load supporting configuration. A switch shall be installed at the cradle to prevent operation of the stabilizers once the aerial has been elevated from the nested position.

10-50 STABILIZER ALARM

An electronic warning device shall be provided at each stabilizer to warn personnel that the stabilizers are being deployed. Each alarm shall produce a fast pulsing 90 DBA signal and shall cancel only when the stabilizer is put into a load bearing configuration.

10-51 STABILIZER SCENE LIGHTS

A clear LED floodlight shall be provided on each stabilizer to illuminate the surrounding area. The light shall be actuated by the aerial master switch.

10-52 STABILIZER WARNING LIGHTS

Four (4) Whelen Model 60*02F*R, flashing Super LED warning light shall be mounted on the stabilizer cover panel, one (1) for each panel.

Front stabilizers LEDs shall be red Super LED/red lens each side.

Rear stabilizers LEDs shall be red Super LED/red lens each side.

These warning lights shall be activated by the NFPA side zone switch.

These lights shall be provided with a flange.

10-53 STABILIZER BEAM WARNING LIGHTS

Red LED flashing lights shall be mounted on each stabilizer, one (1) facing forward and one (1) facing rearward.

These warning lights shall be activated with the aerial master switch.

10-54 120-VOLT RECEPTACLE AT TIP

A 120-volt, 15 amp twist lock receptacle, with a weatherproof cover shall be provided at the tip of the aerial device.

10-55 240 VOLT LIGHTING, TIP OF LADDER

Two (2), Fire Research Corp, FCA100-V08 LED, 8000 lumen lights shall be provided at the tip of the ladder. The lights shall be located on the driver's and passenger's sides.

Lights shall be switched at the light head and turntable.

10-56 RUNG LIGHTING ON AERIAL LADDER

There shall be blue LED rung lighting provided on both sides of the aerial ladder base, lower and upper mid, and fly sections. The LEDs shall serve to illuminate climbing rungs without inducing any glare, which would hinder safety. The lighting shall be located adjacent to the ladder rungs along the lower rail of the ladder sections and shall run the length of the ladder section.

The LED rung lighting shall be activated when the aerial master switch is activated and a switch at the turntable operator's panel is activated through the aerial master.

10-57 TIP / TRACKING LIGHTS

Four (4) Collins, Model FX-12, 750,000 candle power, 12-volt spot/floodlights shall be furnished. The two (2) tracking lights shall be mounted on the bottom of the base section of the ladder, one (1) each side and two mounted at the tip of the fly section, one (1) each side. An individual master switch with appropriate identification labels shall be provided at the turntable console.

10-58 3-WAY AERIAL COMMUNICATION SYSTEM

There shall be a Fire Research model ICA900-213 three-way intercom system provided. There shall be a control module located at the turntable operator console. The control module shall have and an LED volume display and push-button volume control. A hands free module shall be located at the aerial tip or platform and constantly transmit to the other module unless the push-to-talk button is pressed.

Each intercom unit shall be weatherproof.

10-59 LIFTING EYE – ROPE RESCUE ATTACHMENT

A lifting eye or eyes shall be provided at the end of the ladder fly section. The lifting eye(s) shall give the fire department the capabilities to tie off or lift from the ladder fly section, and the design shall distribute a load evenly across the ladder beams.

The lifting eye shall be third party tested and certified with the device for a minimum capacity of 500 pounds. The rating shall include a 2:1 safety factor.

10-60 WATER SYSTEM

A waterway system shall be provided consisting of the following components and features:

A 5.00" pipe connected to the water supply at the rear of the apparatus and to a water swivel at the rotation point of the turntable. The water swivel shall allow the ladder to rotate 360 degrees continuously while flowing water.

A 4.00" waterway swivel is to be routed through the rotation point swivel up to the heel pin swivel. The heel pin swivel shall allow the water to flow to the ladder pipe while elevating the aerial ladder through its full range of elevation. The heel pivot pin is not integral with the waterway swivel at any point. The design of the waterway shall allow complete servicing of the waterway swivel without disturbing the heel pivot pin.

The integral telescopic water system shall be anodized aluminum and be of sufficient diameter to flow the maximum rated gallons per minute listed for the aerial device.

The rotational torque shall have adequate power to rotate the ladder into the maximum rated gallon per minute water stream directed at 90 degrees to the side while maintaining the fully rated tip load.

The aerial waterway system shall be capable of flowing no less than 1000 gallons per minute and accommodate the specified Aerial Monitor (Section 10-65) through the full range of motion available while maintaining the fully rated tip load.

An adjustable intake relief valve shall be furnished to protect the aerial waterway from a pressure surge.

A 1.50" drain valve shall be located at the lowest point of the waterway system.

10-61 WATERWAY SEALS

The waterway seals shall be capable of withstanding pressures up to 2000 psi, temperatures in excess of 250 degrees Fahrenheit and have resistance to all foam generating solutions. The seals shall be internally lubricated.

The waterway seals shall have automatic centering guides. The guides shall provide positive centering of the extendible sections within each other and the base section to insure longer service life and smoother operation.

10-62 AERIAL MONITOR

An Akron model #3598 "StreamMaster" electrically controlled monitor with stow and deploy shall be installed on the outer end of the telescoping aerial waterway. The monitor relay box shall be located on at the tip of the aerial, adjacent to the monitor, and shall be easily accessible for service.

- Vertical travel 45° below and 120° above horizontal
- The monitor shall be equipped with a 3-1/2" outlet and a 4" inlet.
- The monitor shall have a vertical sweep of 165°, and a horizontal sweep of 348°.
- Full range of vertical and horizontal travel shall be accomplished without impacting the full volume flow weight limitations of the ladder

An Akron model #5178 Akromatic electrically controlled master stream nozzle shall be installed on the end of the monitor. The model #5178 shall allow a maximum flow rate of 2000 gpm @ 80 psi.

The monitor's functions shall be controlled electrically from two (2) separate locations. One (1) control shall be located at the control console and the other at the ladder tip.

There shall be a courtesy light at the tip of the aerial to illuminate the controls.

10-63 DUAL POSITION WATERWAY

The waterway monitor shall be retractable, allowing the monitor to be secured at the end the fly section for water tower operations, or at the end of the third ladder section for rescue operations.

In rescue mode, this feature shall allow the tip of the fly section to be placed very close to the edge of a building or window, minimizing the working and access heights on and off the ladder tip, without worrying about the monitor being damaged. Any monitor guards must retract with the monitor to the third ladder section. Permanent monitor guards installed below the tip of the aerial are unacceptable.

An electric actuator or mechanical type waterway positioning system shall both be acceptable; however, there shall be no pins to remove and reinstall. An electrical actuator shall have a manual backup to secure the waterway in the event the electric actuator fails. The monitor shall be operational at all times, regardless of its position, without connecting or disconnecting electrical cables. (NO EXCEPTIONS).

Any monitor power control cord used to accommodate the retractable waterway must be protected from damage, including falling glass, for at least the length of the bolt on ladder tip. Movable monitor designs that require a spring-rewind cord reel for the monitor power/control cord are unacceptable.

The waterway shall retain the same maximum flow capacity, regardless of monitor position.

10-64 FLOW METER (Aerial Waterway)

A Class I Flow-Minder, with totalizer, shall be provided for the aerial waterway. The flow meter shall be located at the turntable control station.

10-65 REAR INLET

A 5.00" male NST inlet to the aerial waterway shall be provided at the rear of the apparatus.

A 5.00" electric operated butterfly valve shall be installed in the aerial waterway controlled at the turntable. There shall be a preset relief valve in the waterway between the butterfly valve and the monitor to protect the waterway when retracting.

10-66 TOOLS

Any and all special tools shall be provided for retorquing of all specified bolts as recommended by the manufacturer including, but not limited to:

- Torque Wrench(s)
- All Required Extensions, Sockets and Adapters
- 4-to-1 Multiplier

10-67 MANUALS

Two (2) operator maintenance manuals and two (2) wiring diagrams pertaining to the aerial device shall be provided with the apparatus at time of pick-up.

11-0 LOOSE EQUIPMENT

The following equipment shall be furnished with the completed unit:

- One (1) bag of chrome, stainless steel, or cadmium plated screws, nuts, bolts and washers, as used in the construction of the unit

12-0 PAINT

The cab and the body shall be painted red, the exact paint code to be determined by the fire department

Prior to reassembly and reinstallation of lights, handrails, door hardware and any miscellaneous items an isolation tape, gasket or dielectric material shall be used to prevent

damage to the finish painted surfaces. (No exception). A nylon washer shall be installed under each acorn nut or metal screw that is fastened directly to an exterior painted surface.

The exterior custom cab and body painting procedure shall consist of a seven (7) step finishing process as follows:

1. Manual Surface Preparation – All exposed metal surfaces on the custom cab and body shall be thoroughly cleaned and prepared for painting. Surfaces that shall not be painted include all chrome plated, polished stainless steel, anodized aluminum and bright aluminum treadplate. Each imperfection on the exterior metal surface shall be removed or filled and then sanded smooth for a smooth appearance. All seams shall be sealed before painting.
2. Chemical cleaning and Treatment – The metal surfaces shall be properly cleaned using a high pressure and high temperature cleaning system. Surfaces are chemically cleaned to remove all dirt, oil, grease and metal oxides to ensure the subsequent coatings bond well. An ultra pure water final rinse shall be applied to all metal surfaces at the conclusion of the metal treatment process.
3. Primer/Surfacer Coats – A two (2) component urethane primer/surfacer shall be hand applied to the chemically treated metal surfaces to provide a strong corrosion protective base coat and.
4. Hand Sanding – The primer/surfacer coat shall be lightly sanded to an ultra smooth finish.
5. Sealer Primer Coat – A two (2) component sealer primer coat shall be applied over the sanded primer.
6. Topcoat Paint – Urethane base coat shall be applied to opacity for correct color matching.
7. Clear coat – Two (2) coats of an automotive grade two (2) component urethane shall be applied. Lap style doors shall be clear coated to match the body. Roll-up doors shall not be clear coated and the standard roll-up door warranty shall apply.

All removable items such as brackets, compartment doors, door hinges, trim, etc. shall be removed and painted separately to insure paint behind all mounted items. Body assemblies that cannot be finish painted after assembly shall be finish painted before assembly.

The cab and the body shall be painted RED similar to PPG FLNA 3235. Paint color to be approved a pre-construction conference.

12-1 PAINT – ENVIRONMENTAL IMPACT

The contractor shall meet or exceed his current State regulations concerning paint operations. Pollution control shall include measures to protect the atmosphere, water and soil. Controls shall include the following conditions:

- Topcoats and primers shall be chrome and lead free.
- Metal treatment chemicals shall be chrome free. The wastewater generated in the metal treatment process shall be treated on-site to remove any other heavy metals.
- Particulate emission collection from sanding operations shall have a 99.99 percent efficiency factor.

- Particulate emissions from painting operations shall be collected by a dry filter or water wash process. If the dry filter means is used, it shall have an efficiency rating of 98 percent. Water wash systems shall be 99.97 percent efficient.
- Water from water wash booths shall be reused. Solids shall be removed mechanically on a continual basis to keep the water clean.
- Paint wastes shall be disposed of in an environmentally safe manner.
- Empty metal paint containers shall be crushed and recycled to recover the metal.
- Solvents used in cleanup operations shall be collected, recycled on-site, or sent off-site for distillation and returned for reuse. Residue from the distillation operation shall be used as fuel in off-site kilns.

Additionally, the finished apparatus shall not be manufactured with or contain products that have ozone depleting substances. The contractor shall, upon demand, present evidence that his manufacturing facility meets the above conditions and that it is in compliance with his State EPA rules and regulations.

12-2 PAINT CHASSIS FRAME ASSEMBLY

The chassis frame assembly shall be painted black before the installation of the cab and body, and before installation of the engine and transmission assembly, air brake lines, electrical wire harnesses, etc. Components that are included with the chassis frame assembly that shall be painted black are frame rails, cross members, axles, suspension, steering gear, fuel tank, body substructure supports, miscellaneous mounting brackets, etc.

12-3 AIR CONDITIONING COVER AND MOUNTS

The cover of the air conditioning condenser and the mounting feet shall be bright aluminum tread plate

12-4 PAINT, COMPARTMENT INTERIOR

Interior of compartmentation shall be painted with gray LINEX style paint

12-5 AERIAL DEVICE PAINT COLOR

The aerial device (turntable and ladder sections) shall be painted a color determined by the fire department. The tip of the ladder shall be painted a contrasting color for high visibility.

13-0 REFLECTIVE STRIPES

Three (3) reflective stripes shall be provided across the front of the vehicle and along the sides of the chassis cab and apparatus body. The reflective band shall consist of a 1.00" blue stripe at the top with a 1.00" gap then a 6.00" white stripe with a 1.00" gap and a 1.00" blue stripe on the bottom.

The reflective band provided on the cab face shall be below the headlights on the fiberglass.

13-1 JOGS IN REFLECTIVE BAND

The reflective band located on each side of the apparatus body shall contain one (1) jog and shall be angled at approximately 45 degrees when installed.

13-2 CHEVRON STRIPING

There shall be alternating chevron striping located on the rear-facing vertical surface of the apparatus. Covered surfaces shall include the rear wall and aluminum doors. Rear compartment doors, stainless steel access doors, and the rear bumper shall not be covered.

Alternating chevron striping shall be placed on the painted front bumper.

The colors shall be red and fluorescent yellow green diamond grade.

Each stripe shall be 6.00" in width.

This shall meet the requirements of NFPA 1901, 2009 edition, which states that 50% of the rear surface shall be covered with chevron striping.

13-3 REFLECTIVE STRIPE ON STABILIZERS

There shall be 4.00" wide alternating ruby red and fluorescent yellow green diamond grade reflective chevron stripes provided on the forward and rear facing sides of all four (4) aerial stabilizers. The stripes shall be angled at a 45 degree angle.

13-4 REFLECTIVE STRIPE, CAB DOORS

A 6.00" x 16.00" ruby red reflective stripe shall be provided across the interior of each cab door. The stripe shall be located approximately 1.00" up from the bottom, on the door panel.

This stripe shall meet the NFPA 1901 requirement.

14-0 BOOM SIGN STRIPING

There shall be genuine gold leaf stripes along all edges of the aerial boom sign. Lettering shall be provided to match fire department apparatus. Painted aluminum panels shall be furnished on each side of the aerial device base section. The panels shall be approximately 19" high X 144" long. The sign panels shall be painted to match the apparatus ladder paint color.

14-1 LETTERING

The lettering shall be totally encapsulated between two (2) layers of clear vinyl.

14-2 LETTERING – (cab and body)

Forty-one (41) to sixty (60) genuine gold leaf letters, 3.00" high, with outline and double shade shall be provided.

14-3 LETTERING – (cab)

There shall be reflective lettering, 5.00" high, with outline and shade provided. There shall be six (6) letters provided.

14-4 LETTERING – (aerial boom panel)

There shall be genuine gold leaf lettering, 10.00" high, with outline and double shade provided. There shall be eighteen (18) letters provided.

14-5 LETTERING – (aerial boom panel)

There shall be genuine gold leaf lettering, 6.00” high, with outline and double shade provided. There shall be eighteen (18) letters provided.

14-6 LETTERING

One (1) to twenty (20) reflective letters, 3.00” high, with outline and shade shall be provided.

14-7 LETTERING

There shall be reflective lettering, 6.00” high, with outline and shade provided. There shall be one (1) letter provided.

14-8 LETTERING

There shall be reflective lettering, 10.00” high, with outline and shade provided. There shall be three (3) letters provided to be placed on the plate specified in section 15-12.

14-9 REAR COMPARTMENT DOOR LETTERING

There shall be one (1) 24.00” numerical lettering on both sides of the truck on that door, to be intertwined with the reflective horizontal striping. It shall denote the number of the ladder truck

14-10 REAR LADDER TUNNEL DOOR LETTERING

5” lettering on the back door denoting the company LADDER (arched across the top) The number of the ladder in the center, TBD, and it will be 8.00” COMPANY on the bottom and running straight horizontal.

14-11 FRONT BUMPER LETTERING

The front bumper shall have lettering in the center that denotes the following LAD(TBD)DER with 4.00” lettering and the number to be 6.00”.

14-12 PLATE FOR DEPARTMENT NUMBERS

There shall be two (2) aluminum plates, 12” x 12” provided on the fly section. The plate shall be painted the color of the ladder. One pair of decals shall be applied with company number designation.

15-0 MANUAL, FIRE APPARATUS PARTS

Custom parts manuals for the complete fire apparatus shall be provided in hard copy with the completed unit. There shall be two (2) hard copies and an electronic copy.

The manual shall contain the following:

- Job number
- Part numbers with full descriptions
- Table of contents
- Parts section sorted in functional groups reflecting a major system, component, or assembly
- Parts section sorted in Alphabetical order

- Third party part numbers cross reference
- Instructions on how to locate a part

The manual shall be specifically written for the chassis and body model being purchased. It shall not be a generic manual for a multitude of different chassis and bodies.

15-1 SERVICE PARTS INTERNET SITE

The service parts information included in this manual is also available on the factory website. The website offers additional functions and features not contained in this manual, such as digital photographs and line drawings of select items. The website also features electronic search tools to assist in locating parts quickly.

16-0 MANUALS, CHASSIS SERVICE

Chassis service manuals containing parts and service information on major components shall be provided with the completed unit. There shall be two (2) hard copies and an electronic copy.

The manuals shall contain the following sections:

- Job number
- Table of contents
- Troubleshooting
- Front Axle/Suspension
- Brakes
- Engine
- Tires
- Wheels
- Cab
- Electrical, DC
- Air Systems
- Plumbing
- Appendix

The manual shall be specifically written for the chassis model being purchased. It shall not be a generic manual for a multitude of different chassis and bodies.

16-1 MANUALS, CHASSIS OPERATION

Chassis operation manuals shall be provided. There shall be two (2) hard copies and an electronic copy.

17-0 ONE (1) YEAR MATERIAL AND WORKMANSHIP

Each new piece of apparatus shall be provided with a minimum one (1) year basic apparatus material and workmanship limited warranty. The warranty shall cover such portions of the apparatus built by the

manufacturer as being free from defects in material and workmanship that would arise under normal use and service.

A copy of the warranty certificate shall be submitted with the bid package. (No exception).

17-1 THREE (3) YEAR MATERIAL AND WORKMANSHIP

The new chassis shall be provided with a three (3) year material and workmanship limited warranty. The warranty shall cover such portions of the chassis built by the manufacturer as being free from structural failures caused by defects in material and workmanship that would arise under normal use and service.

A copy of the warranty certificate shall be submitted with the bid package (No Exception).

17-2 ENGINE WARRANTY

A Cummins five (5) year limited engine warranty shall be provided. A copy of the warranty certificate shall be submitted with the bid package.

17-3 STEERING GEAR WARRANTY

A Sheppard three (3) year limited steering gear warranty shall be provided. A copy of the warranty certificate shall be submitted with the bid package.

17-4 FIFTY (50) YEAR STRUCTURAL INTEGRITY

The chassis frame and cross members shall be provided with a fifty (50) year material and workmanship limited warranty. The warranty shall cover the chassis frame and cross members as being free from defects in material and workmanship that would arise under normal use and service.

A copy of the warranty certificate shall be submitted with the bid package (No Exception).

17-5 FRONT AXLE THREE (3) YEAR MATERIAL AND WORKMANSHIP WARRANTY

Independent front suspension shall be provided with a three (3) year material and workmanship limited warranty. The manufacturer's warranty shall provide that the independent front suspension and steering gears be free from any defect related to material and workmanship on the portion of the apparatus built by the manufacturer that would arise under normal use and service. A copy of the warranty certificate shall be submitted with the bid package (No Exception).

17-6 REAR AXLE TWO (2) YEAR MATERIAL AND WORKMANSHIP WARRANTY

A Meritor™ Axle 2 year limited warranty shall be provided.

17-7 TEN (10) YEAR STRUCTURAL INTEGRITY

The new cab shall be provided with a ten (10) year material and workmanship limited warranty. The warranty shall cover such portions of the cab built by the manufacturer as being free from structural failures caused by defects in material and workmanship that would arise under normal use and service.

A copy of the warranty certificate shall be submitted with the bid package (No Exception).

17-8 PAINT AND CORROSION

Each new piece of apparatus shall be provided with paint and corrosion limited warranty on the apparatus cab. The warranty shall cover painted exterior surfaces of the body to be free from blistering, peeling, corrosion, or any other adhesion defect caused by defective manufacturing methods or paint material selection that would arise under normal use and service.

A copy of the warranty certificate shall be submitted with the bid package (No Exception).

17-9 FIVE (5) YEAR MATERIAL AND WORKMANSHIP

The electronic modules and display(s) shall be provided with a five (5) year material and workmanship limited warranty. The warranty shall cover electronic modules to be free from failures caused by defects in material and workmanship.

A copy of the warranty certificate shall be submitted with the bid package (No Exception).

17-10 TRANSMISSION WARRANTY

The transmission shall have a **five (5) year/unlimited mileage** warranty covering 100 percent parts and labor. The warranty is to be provided by Allison Transmission and not the apparatus builder.

17-11 TRANSMISSION COOLER WARRANTY

The transmission cooler shall carry a five (5) year parts and labor warranty (exclusive to the transmission cooler). In addition, a collateral damage warranty shall also be in effect for the first three (3) years of the warranty coverage and shall not exceed \$10,000 per occurrence. A copy of the warranty certificate shall be submitted with the bid package.

17-12 TEN (10) YEAR STRUCTURAL INTEGRITY

Each new piece of apparatus shall be provided with a ten (10) year material and workmanship limited warranty on the apparatus body. The warranty shall cover such portions of the apparatus built by the manufacturer as being free from defects in material and workmanship that would arise under normal use and service.

A copy of the warranty certificate shall be submitted with the bid package (No Exception).

17-13 ROLL UP DOOR MATERIAL AND WORKMANSHIP WARRANTY

An Amdor roll-up door limited warranty shall be provided. The mechanical components of the roll-up door shall be warranted against defects in material and workmanship for the lifetime of the vehicle. A six (6) year limited warranty shall be provided on painted and satin roll up doors.

A copy of the warranty certificate shall be submitted with the bid package.

17-14 TWENTY (20) YEAR AERIAL DEVICE STRUCTURAL INTEGRITY WARRANTY

The aerial device shall be provided with a twenty (20) year material and workmanship limited warranty. The warranty shall cover such portions of the apparatus built by the manufacturer as being free from defects in material and workmanship that would arise under normal use and service. This warranty shall be limited to the torque box, turntable, aerial sections and other structural components.

A copy of the warranty certificate shall be submitted with the bid package (No Exception).

17-15 AERIAL SWIVEL WARRANTY

A five (5) year limited swivel warranty shall be provided. A copy of the warranty certificate shall be submitted with the bid package (No Exception).

17-16 HYDRAULIC SYSTEM COMPONENTS WARRANTY

Aerial hydraulic system components shall be provided with a five (5) year material and workmanship limited warranty.

17-17 HYDRAULIC SEAL WARRANTY

Aerial hydraulic seals shall be provided with a three (3) year material and workmanship limited warranty.

A copy of the warranty certificates shall be submitted with the bid package (No Exception).

17-18 AERIAL WATERWAY WARRANTY

An Amity ten (10) year limited waterway warranty shall be provided. A copy of the warranty certificate shall be submitted with the bid package (no exception).

17-19 FOUR (4) YEAR PRO-RATED PAINT AND CORROSION

The aerial device shall be provided with a four (4) year pro-rated paint and corrosion limited warranty. The warranty shall cover exterior painted surfaces of the aerial device to be free from blistering, peeling, corrosion, or any other adhesion defect caused by defective manufacturing methods or paint material selection that would arise under normal use and service.

A copy of the warranty certificate shall be submitted with the bid package (No Exception).

17-20 TEN (10) YEAR PRO-RATED PAINT AND CORROSION

Each new piece of apparatus shall be provided with a ten (10) year pro-rated paint and corrosion limited warranty on the apparatus body. The warranty shall cover painted exterior surfaces of the body to be free from blistering, peeling, corrosion, or any other adhesion defect caused by defective manufacturing methods or paint material selection that would arise under normal use and service.

A copy of the warranty certificate shall be submitted with the bid package (No Exception).

17-21 THREE (3) YEAR MATERIAL AND WORKMANSHIP

The gold leaf lamination shall be provided with a three (3) year material and workmanship limited warranty. The warranty shall cover the gold leaf lamination as being free from defects in material and workmanship that would arise under normal use and service.

A copy of the warranty certificate shall be submitted with the bid package (No Exception).

17-22 VEHICLE STABILITY CERTIFICATION

The fire apparatus manufacturer shall provide a certification stating the apparatus complies with NFPA 1901, current edition, section 4.13, Vehicle Stability. The certification shall be provided at the time of bid.

17-23 ENGINE INSTALLATION CERTIFICATION

The fire apparatus manufacturer shall provide a certification, along with a letter from the engine manufacturer stating they approve of the engine installation in the bidder's chassis. The certification shall be provided at the time of delivery.

17-24 POWER STEERING CERTIFICATION

The fire apparatus manufacturer shall provide a certification stating the power steering system as installed meets the requirements of the component supplier. The certification shall be provided at the time of bid.

17-25 CAB INTEGRITY CERTIFICATION

The fire apparatus manufacturer shall provide a cab integrity certification with this proposal. The certification shall state that the cab has been tested and certified by an independent third-party test facility. Testing events shall be documented with photographs, real-time and high-speed video, vehicle accelerometers, cart accelerometers, and a laser speed trap. The fire apparatus manufacturer shall provide a state-licensed professional engineer to witness and certify all testing events. Testing shall meet or exceed the requirements below:

- European Occupant Protection Standard ECE Regulation No.29.
- SAE J2422 Cab Roof Strength Evaluation – Quasi-Static Loading Heavy Trucks.
- SAE J2420 COE Frontal Strength Evaluation – Dynamic Loading Heavy Trucks.
- Roof Crush

The cab shall be subjected to a roof crush force of 22,050 lbs. This value meets the ECE 29 criteria and is equivalent to the front axle rating up to a maximum of 10 metric tons.

- Additional Roof Crush

The same cab shall be subjected to a roof crush force of 100,000 lbs. This value exceeds the ECE 29 criteria by nearly 4.5 times.

- Side Impact

The same cab shall be subjected to dynamic preload where a 13,275 lb moving barrier slams into the side of the cab at 5.5 mph at a force of 13,000 ft-lbs. This test is part of the SAE J2422 test procedure and more closely represents the forces a cab shall see in a rollover incident.

- Frontal Impact

The same cab shall withstand a frontal impact of 32,600 ft-lbs of force using a moving barrier in accordance with SAE J2420.

10 Additional Frontal Impact

The same cab shall withstand a frontal impact of 65,200 ft-lbs of force using a moving barrier, (twice the force required by SAE J2420).

The same cab shall withstand all tests without any measurable intrusion into the survival space of the occupant area.

There shall be no exception to any portion of the cab integrity certification. Nonconformance shall lead to immediate rejection of bid.

17-26 CAB DOOR DURABILITY CERTIFICATION

Robust cab doors help protect occupants. Cab doors shall survive a 200,000 cycle door slam test where the slamming force exceeds 20 G's of deceleration. The bidder shall certify that the sample doors similar to those provided on the apparatus have been tested and have met these criteria without structural damage, latch malfunction, or significant component wear.

17-27 WINDSHIELD WIPER DURABILITY CERTIFICATION

Visibility during inclement weather is essential to safe apparatus performance. Windshield wipers shall survive a 3 million cycle durability test in accordance with section 6.2 of SAE J198 *Windshield Wiper Systems – Trucks, Buses and Multipurpose Vehicles*. The bidder shall certify that the wiper system design has been tested and that the wiper system has met these criteria.

17-28 ELECTRIC WINDOW DURABILITY CERTIFICATION

Cab window roll-up systems can cause maintenance problems if not designed for long service life. The window regulator design shall complete 30,000 complete up-down cycles and still function normally when finished. The bidder shall certify that sample doors and windows similar to those provided on the apparatus have been tested and have met these criteria without malfunction or significant component wear.

17-29 SEAT BELT ANCHOR STRENGTH

Seat belt attachment strength is regulated by Federal Motor Vehicle Safety Standards and should be validated through testing. Each seat belt anchor design shall withstand 3000 lb of pull on both the lap and shoulder belt in accordance with FMVSS 571.210 Seat Belt Assembly Anchorages. The bidder shall certify that each anchor design was pull tested to the required force and met the appropriate criteria.

17-30 SEAT MOUNTING STRENGTH

Seat attachment strength is regulated by Federal Motor Vehicle Safety Standards and should be validated through testing. Each seat mounting design shall be tested to withstand 20 G's of force in accordance with FMVSS 571.207 Seating Systems. The bidder shall certify that each seat mount and cab structure design was pull tested to the required force and met the appropriate criteria.

17-31 CAB DEFROSTER CERTIFICATION

Visibility during inclement weather is essential to safe apparatus performance. The defroster system shall clear the required windshield zones in accordance with SAE J381 *Windshield Defrosting Systems Test Procedure and Performance Requirements – Trucks, Buses, and Multipurpose Vehicles*. The bidder shall certify that the defrost system design has been tested in a cold chamber and passes the SAE J381 criteria.

17-32 CAB HEATER CERTIFICATION

Good cab heat performance and regulation provides a more effective working environment for personnel, whether in-transit, or at a scene. The cab heaters shall warm the cab 75 F from a cold-soak, within 30 minutes when tested using the coolant supply methods found in SAE J381. The bidder shall certify that a substantially similar cab has been tested and has met these criteria.

17-33 CAB AIR CONDITIONING PERFORMANCE CERTIFICATION

Good cab air conditioning temperature and air flow performance keeps occupants comfortable, reduces humidity, and provides a climate for recuperation while at the scene. The cab air conditioning system shall cool the cab from a heat-soaked condition at 100 degrees Fahrenheit to an average of 67 degrees Fahrenheit in 30 minutes. The bidder shall certify that a substantially similar cab has been tested and has met these criteria.

17-34 AMP DRAW REPORT

The bidder shall provide, at the time of bid and delivery, an itemized print out of the expected amp draw of the entire vehicle's electrical system.

The manufacturer of the apparatus shall provide the following:

- 1) Documentation of the electrical system performance tests.
- 2) A written load analysis, which shall include the following:
 - A) The nameplate rating of the alternator.
 - B) The alternator rating under the conditions specified per:
 - Applicable NFPA 1901 or 1906 (Current Edition).
 - C) The minimum continuous load of each component that is specified per:
 - Applicable NFPA 1901 or 1906 (Current Edition).
 - D) Additional loads that, when added to the minimum continuous load, determine the total connected load.
 - E) Each individual intermittent load.

All of the above listed items shall be provided by the bidder per the applicable NFPA 1901 or 1906 (Current Edition).



Fire and Rescue Apparatus

One (1) Year Material and Workmanship

Basic Apparatus

Limited Warranty

1. LIMITED WARRANTY

Subject to the limitations and exclusions set forth below, Pierce Manufacturing provides the following warranty to the Buyer:

Coverage:	Portions of the apparatus manufactured by Pierce shall be free from defects in material and workmanship
Warranty Begins:	The date the apparatus is placed in service, or 60 days from the original buyer invoice date, whichever comes first.
Warranty Period Ends After:	Twelve (12) months.
Conditions and Exclusions:	No specific exclusions apply
See Also Paragraphs 2 thru 4	

This limited warranty shall apply only if the product is properly maintained in accordance with Pierce's maintenance instructions and manuals and is used in service which is normal to the particular model. Normal service means service which does not subject the product to stresses or impacts greater than normally result from careful use. If the Buyer discovers a defect or nonconformity, it must notify Pierce in writing within thirty (30) days after the date of discovery, but in any event prior to the expiration of the warranty period. THIS LIMITED WARRANTY MAY NOT BE ASSIGNED OR OTHERWISE TRANSFERRED BY THE BUYER TO ANY SUBSEQUENT USER OR PURCHASER OR TO ANY OTHER PERSON OR ENTITY.

Notwithstanding anything to the contrary herein, Pierce makes no warranty whatsoever as to:

(a) any integral parts, components, attachments or trade accessories of or to the product that are not manufactured by Pierce, including but not limited to engines, transmissions, drivelines, axles, water pumps and generators; with respect to all such parts, components, attachments and accessories, Pierce shall assign to Buyer the applicable warranties, if any, made by the respective manufacturers thereof;

(b) any vehicle, chassis, or component, part, attachment or accessory damaged by misuse, neglect, fire, exposure to severe environmental or chemical conditions, acidic environment, improper maintenance, accident, crash, or force majeure such as natural disaster, lightning, earthquake, windstorm, hail, flood, war or riot;

(c) any vehicle, chassis or component, part, attachment or accessory that has been repaired, altered or assembled in any way by any person or entity other than Pierce which, in the sole judgment of Pierce, adversely affects the performance, stability or purpose for which it was manufactured; or

(d) products or parts which may in the ordinary course wear out and have to be replaced during the warranty period, including, but not limited to, tires, fluids, gaskets and light bulbs. Pierce assumes no responsibility for the assembly of its parts or subassemblies into finishing products or vehicles unless the assembly is performed by Pierce.

The original purchaser may void this warranty in part or in its entirety if the product is repaired or replaced (a) without prior written approval of the Pierce Customer Service Department; or (b) at a facility which has not been approved by Pierce as to technical capability. Any repairs, modifications, alterations or aftermarket parts added after manufacture without the authorization of Pierce may void this warranty.

2. DISCLAIMERS OF WARRANTIES

THE WARRANTY SET FORTH IN PARAGRAPH 1 IS THE SOLE AND EXCLUSIVE WARRANTY GIVEN BY PIERCE. PIERCE HEREBY DISCLAIMS AND EXCLUDES ALL OTHER WARRANTIES, WHETHER EXPRESS, IMPLIED OR STATUTORY, INCLUDING WITHOUT LIMITATION ANY WARRANTY OF MERCHANTABILITY, ANY WARRANTY OF FITNESS FOR A PARTICULAR PURPOSE, AND ANY WARRANTIES ARISING FROM COURSE OF DEALING OR USAGE OF TRADE.

3. BUYER'S EXCLUSIVE REMEDY.

If the product fails to conform to the warranty set forth in paragraph 1 during the warranty period, and such nonconformity is not due to misuse, neglect, accident or improper maintenance, Buyer must notify Pierce within the time period specified in paragraph 1, and shall make the product available for inspection by Pierce or its designated agent. At the request of Pierce, any allegedly defective product shall be returned to Pierce by Buyer for examination and/or repair. Buyer shall be responsible for the cost of such transportation, and for risk of loss of or damage to the product during transportation. Within a reasonable time, Pierce shall repair or replace (at Pierce's option and expense) any nonconforming or defective parts. Repair or replacement shall be made only by a facility approved in advance in writing by Pierce. THIS REMEDY SHALL BE THE EXCLUSIVE AND SOLE REMEDY FOR ANY BREACH OF WARRANTY.

4. EXCLUSION OF CONSEQUENTIAL AND INCIDENTAL DAMAGES.

Notwithstanding anything to the contrary herein or in any agreement between Pierce and Buyer, IN NO EVENT SHALL PIERCE BE LIABLE FOR ANY CONSEQUENTIAL, INCIDENTAL, SPECIAL, INDIRECT, OR PUNITIVE DAMAGES WHATSOEVER, WHETHER ARISING OUT OF BREACH OF CONTRACT, WARRANTY, TORT (INCLUDING NEGLIGENCE AND STRICT LIABILITY) OR OTHER THEORY OF LAW OR EQUITY, WITH RESPECT TO VEHICLES OR OTHER PRODUCTS SOLD BY PIERCE, OR THEIR OPERATION OR FAILURE TO OPERATE, OR ANY DEFECTS THEREIN, OR ANY UNDERTAKINGS, ACTS OR OMISSIONS RELATED THERETO, REGARDLESS OF WHETHER PIERCE HAS BEEN INFORMED OF THE POSSIBILITY OF ANY SUCH DAMAGES. Without limiting the generality of the foregoing, Pierce specifically disclaims any liability for property or personal injury damages, penalties, damages for lost profits or revenues, loss of vehicles or products or any associated equipment, cost of substitute vehicles or products, down-time, delay damages, any other types of economic loss, or for any claims by any third party for any such damages.

Note: Any Surety Bond, if a part of the sale of the vehicle as to which this limited warranty is provided, applies only to this Pierce Basic One Year Limited Warranty for such vehicle, and not to other warranties made by Pierce in a separate document (if any) or to the warranties (if any) made by any manufacturer (other than Pierce) of any part, component, attachment or accessory that is incorporated into or attached to the vehicle.



Fire and Rescue Apparatus

Ten (10) Year Structural Integrity

Custom Cab

Limited Warranty

1. LIMITED WARRANTY

Subject to the limitations and exclusions set forth below, Pierce Manufacturing provides the following warranty to the Buyer:

Coverage:	The Pierce Custom Cab shall be free from structural failures caused by defects in material and workmanship
Warranty Begins:	The date of the original purchase invoice (issued when the product ships from the factory).
Warranty Period Ends After:	Ten (10) Years - or - 100,000 Miles
Conditions and Exclusions:	This warranty applies only to the cab tubular support and mounting structures and other structural components of the cab of the vehicle model, as identified in the Pierce specifications for the Fire and Rescue Apparatus.
See Also Paragraphs 2 thru 4	This warranty does not apply to damage caused by corrosion.

This limited warranty shall apply only if the product is properly maintained in accordance with Pierce's maintenance instructions and manuals and is used in service which is normal to the particular model. Normal service means service which does not subject the product to stresses or impacts greater than normally result from careful use. If the Buyer discovers a defect or nonconformity, it must notify Pierce in writing within thirty (30) days after the date of discovery, but in any event prior to the expiration of the warranty period. THIS LIMITED WARRANTY MAY NOT BE ASSIGNED OR OTHERWISE TRANSFERRED BY THE BUYER TO ANY SUBSEQUENT USER OR PURCHASER OR TO ANY OTHER PERSON OR ENTITY.

Notwithstanding anything to the contrary herein, Pierce makes no warranty whatsoever as to:

(a) any integral parts, components, attachments or trade accessories of or to the product that are not manufactured by Pierce, including but not limited to engines, transmissions, drivelines, axles, water pumps and generators; with respect to all such parts, components, attachments and accessories, Pierce shall assign to Buyer the applicable warranties, if any, made by the respective manufacturers thereof;

(b) any vehicle, chassis, or component, part, attachment or accessory damaged by misuse, neglect, fire, exposure to severe environmental or chemical conditions, acidic environment, improper maintenance, accident, crash, or force majeure such as natural disaster, lightning, earthquake, windstorm, hail, flood, war or riot;

(c) any vehicle, chassis or component, part, attachment or accessory that has been repaired, altered or assembled in any way by any person or entity other than Pierce which, in the sole judgment of Pierce, adversely affects the performance, stability or purpose for which it was manufactured; or

(d) products or parts which may in the ordinary course wear out and have to be replaced during the warranty period, including, but not limited to, tires, fluids, gaskets and light bulbs. Pierce assumes no responsibility for the assembly of its parts or subassemblies into finishing products or vehicles unless the assembly is performed by Pierce.

The original purchaser may void this warranty in part or in its entirety if the product is repaired or replaced (a) without prior written approval of the Pierce Customer Service Department; or (b) at a facility which has not been approved by Pierce as to technical capability. Any repairs, modifications, alterations or aftermarket parts added after manufacture without the authorization of Pierce may void this warranty.

2. DISCLAIMERS OF WARRANTIES

THE WARRANTY SET FORTH IN PARAGRAPH 1 IS THE SOLE AND EXCLUSIVE WARRANTY GIVEN BY PIERCE. PIERCE HEREBY DISCLAIMS AND EXCLUDES ALL OTHER WARRANTIES, WHETHER EXPRESS, IMPLIED OR STATUTORY, INCLUDING WITHOUT LIMITATION ANY WARRANTY OF MERCHANTABILITY, ANY WARRANTY OF FITNESS FOR A PARTICULAR PURPOSE, AND ANY WARRANTIES ARISING FROM COURSE OF DEALING OR USAGE OF TRADE.

3. BUYER'S EXCLUSIVE REMEDY

If the product fails to conform to the warranty set forth in paragraph 1 during the warranty period, and such nonconformity is not due to misuse, neglect, accident or improper maintenance, Buyer must notify Pierce within the time period specified in paragraph 1, and shall make the product available for inspection by Pierce or its designated agent. At the request of Pierce, any allegedly defective product shall be returned to Pierce by Buyer for examination and/or repair. Buyer shall be responsible for the cost of such transportation, and for risk of loss of or damage to the product during transportation. Within a reasonable time, Pierce shall repair or replace (at Pierce's option and expense) any nonconforming or defective parts. Repair or replacement shall be made only by a facility approved in advance in writing by Pierce. THIS REMEDY SHALL BE THE EXCLUSIVE AND SOLE REMEDY FOR ANY BREACH OF WARRANTY.

4. EXCLUSION OF CONSEQUENTIAL AND INCIDENTAL DAMAGES

Notwithstanding anything to the contrary herein or in any agreement between Pierce and Buyer, IN NO EVENT SHALL PIERCE BE LIABLE FOR ANY CONSEQUENTIAL, INCIDENTAL, SPECIAL, INDIRECT, OR PUNITIVE DAMAGES WHATSOEVER, WHETHER ARISING OUT OF BREACH OF CONTRACT, WARRANTY, TORT (INCLUDING NEGLIGENCE AND STRICT LIABILITY) OR OTHER THEORY OF LAW OR EQUITY, WITH RESPECT TO VEHICLES OR OTHER PRODUCTS SOLD BY PIERCE, OR THEIR OPERATION OR FAILURE TO OPERATE, OR ANY DEFECTS THEREIN, OR ANY UNDERTAKINGS, ACTS OR OMISSIONS RELATED THERETO, REGARDLESS OF WHETHER PIERCE HAS BEEN INFORMED OF THE POSSIBILITY OF ANY SUCH DAMAGES. Without limiting the generality of the foregoing, Pierce specifically disclaims any liability for property or personal injury damages, penalties, damages for lost profits or revenues, loss of vehicles or products or any associated equipment, cost of substitute vehicles or products, down-time, delay damages, any other types of economic loss, or for any claims by any third party for any such damages.

Note: Any Surety Bond, if a part of the sale of the vehicle as to which this limited warranty is provided, applies only to this Pierce Basic One Year Limited Warranty for such vehicle, and not to other warranties made by Pierce in a separate document (if any) or to the warranties (if any) made by any manufacturer (other than Pierce) of any part, component, attachment or accessory that is incorporated into or attached to the vehicle.



Fire and Rescue Apparatus

Lifetime Fifty (50) Year Structural Integrity

Custom Chassis Frame

Limited Warranty

1. LIMITED WARRANTY

Subject to the limitations and exclusions set forth below, Pierce Manufacturing provides the following warranty to the Buyer:

Coverage:	Custom chassis frame rail manufactured by Pierce shall be free from defects in material and workmanship
Warranty Begins:	The date of the original purchase invoice (issued when the product ships from the factory).
Warranty Period Ends After:	Fifty (50) Years (Expected Life of Apparatus)
Conditions and Exclusions:	This warranty does not apply to damage caused by corrosion.
See Also Paragraphs 2 thru 4	

This limited warranty shall apply only if the product is properly maintained in accordance with Pierce's maintenance instructions and manuals and is used in service which is normal to the particular model. Normal service means service which does not subject the product to stresses or impacts greater than normally result from careful use. If the Buyer discovers a defect or nonconformity, it must notify Pierce in writing within thirty (30) days after the date of discovery, but in any event prior to the expiration of the warranty period. THIS LIMITED WARRANTY MAY NOT BE ASSIGNED OR OTHERWISE TRANSFERRED BY THE BUYER TO ANY SUBSEQUENT USER OR PURCHASER OR TO ANY OTHER PERSON OR ENTITY.

Notwithstanding anything to the contrary herein, Pierce makes no warranty whatsoever as to:

(a) any integral parts, components, attachments or trade accessories of or to the product that are not manufactured by Pierce, including but not limited to engines, transmissions, drivelines, axles, water pumps and generators; with respect to all such parts, components, attachments and accessories, Pierce shall assign to Buyer the applicable warranties, if any, made by the respective manufacturers thereof;

(b) any vehicle, chassis, or component, part, attachment or accessory damaged by misuse, neglect, fire, exposure to severe environmental or chemical conditions, acidic environment, improper maintenance, accident, crash, or force majeure such as natural disaster, lightning, earthquake, windstorm, hail, flood, war or riot;

(c) any vehicle, chassis or component, part, attachment or accessory that has been repaired, altered or assembled in any way by any person or entity other than Pierce which, in the sole judgment of Pierce, adversely affects the performance, stability or purpose for which it was manufactured; or

(d) products or parts which may in the ordinary course wear out and have to be replaced during the warranty period, including, but not limited to, tires, fluids, gaskets and light bulbs. Pierce assumes no responsibility for the assembly of its parts or subassemblies into finishing products or vehicles unless the assembly is performed by Pierce.

The original purchaser may void this warranty in part or in its entirety if the product is repaired or replaced (a) without prior written approval of the Pierce Customer Service Department; or (b) at a facility which has not been approved by Pierce as to technical capability. Any repairs, modifications, alterations or aftermarket parts added after manufacture without the authorization of Pierce may void this warranty.

2. DISCLAIMERS OF WARRANTIES

THE WARRANTY SET FORTH IN PARAGRAPH 1 IS THE SOLE AND EXCLUSIVE WARRANTY GIVEN BY PIERCE. PIERCE HEREBY DISCLAIMS AND EXCLUDES ALL OTHER WARRANTIES, WHETHER EXPRESS, IMPLIED OR STATUTORY, INCLUDING WITHOUT LIMITATION ANY WARRANTY OF MERCHANTABILITY, ANY WARRANTY OF FITNESS FOR A PARTICULAR PURPOSE, AND ANY WARRANTIES ARISING FROM COURSE OF DEALING OR USAGE OF TRADE.

3. BUYER'S EXCLUSIVE REMEDY.

If the product fails to conform to the warranty set forth in paragraph 1 during the warranty period, and such nonconformity is not due to misuse, neglect, accident or improper maintenance, Buyer must notify Pierce within the time period specified in paragraph 1, and shall make the product available for inspection by Pierce or its designated agent. At the request of Pierce, any allegedly defective product shall be returned to Pierce by Buyer for examination and/or repair. Buyer shall be responsible for the cost of such transportation, and for risk of loss of or damage to the product during transportation. Within a reasonable time, Pierce shall repair or replace (at Pierce's option and expense) any nonconforming or defective parts. Repair or replacement shall be made only by a facility approved in advance in writing by Pierce. THIS REMEDY SHALL BE THE EXCLUSIVE AND SOLE REMEDY FOR ANY BREACH OF WARRANTY.

4. EXCLUSION OF CONSEQUENTIAL AND INCIDENTAL DAMAGES.

Notwithstanding anything to the contrary herein or in any agreement between Pierce and Buyer, IN NO EVENT SHALL PIERCE BE LIABLE FOR ANY CONSEQUENTIAL, INCIDENTAL, SPECIAL, INDIRECT, OR PUNITIVE DAMAGES WHATSOEVER, WHETHER ARISING OUT OF BREACH OF CONTRACT, WARRANTY, TORT (INCLUDING NEGLIGENCE AND STRICT LIABILITY) OR OTHER THEORY OF LAW OR EQUITY, WITH RESPECT TO VEHICLES OR OTHER PRODUCTS SOLD BY PIERCE, OR THEIR OPERATION OR FAILURE TO OPERATE, OR ANY DEFECTS THEREIN, OR ANY UNDERTAKINGS, ACTS OR OMISSIONS RELATED THERETO, REGARDLESS OF WHETHER PIERCE HAS BEEN INFORMED OF THE POSSIBILITY OF ANY SUCH DAMAGES. Without limiting the generality of the foregoing, Pierce specifically disclaims any liability for property or personal injury damages, penalties, damages for lost profits or revenues, loss of vehicles or products or any associated equipment, cost of substitute vehicles or products, down-time, delay damages, any other types of economic loss, or for any claims by any third party for any such damages.

Note: Any Surety Bond, if a part of the sale of the vehicle as to which this limited warranty is provided, applies only to this Pierce Basic One Year Limited Warranty for such vehicle, and not to other warranties made by Pierce in a separate document (if any) or to the warranties (if any) made by any manufacturer (other than Pierce) of any part, component, attachment or accessory that is incorporated into or attached to the vehicle.



Fire and Rescue Apparatus

Ten (10) Year Structural Integrity Apparatus Body

Limited Warranty

1. LIMITED WARRANTY

Subject to the limitations and exclusions set forth below, Pierce Manufacturing provides the following warranty to the Buyer:

Coverage:	The apparatus body shall be free from structural failures caused by defects in material and workmanship
Warranty Begins:	The date of the original purchase invoice (issued when the product ships from the factory).
Warranty Period Ends After:	Ten (10) Years - or - 100,000 Miles
Conditions and Exclusions: See Also Paragraphs 2 thru 4	This warranty applies only to the body tubular support and mounting structures and other structural components of the body of the vehicle model, as identified in the Pierce specifications for the Fire and Rescue Apparatus. This warranty does not apply to damage caused by corrosion.

This limited warranty shall apply only if the product is properly maintained in accordance with Pierce's maintenance instructions and manuals and is used in service which is normal to the particular model. Normal service means service which does not subject the product to stresses or impacts greater than normally result from careful use. If the Buyer discovers a defect or nonconformity, it must notify Pierce in writing within thirty (30) days after the date of discovery, but in any event prior to the expiration of the warranty period. THIS LIMITED WARRANTY MAY NOT BE ASSIGNED OR OTHERWISE TRANSFERRED BY THE BUYER TO ANY SUBSEQUENT USER OR PURCHASER OR TO ANY OTHER PERSON OR ENTITY.

Notwithstanding anything to the contrary herein, Pierce makes no warranty whatsoever as to:

(a) any integral parts, components, attachments or trade accessories of or to the product that are not manufactured by Pierce, including but not limited to engines, transmissions, drivelines, axles, water pumps and generators; with respect to all such parts, components, attachments and accessories, Pierce shall assign to Buyer the applicable warranties, if any, made by the respective manufacturers thereof;

(b) any vehicle, chassis, or component, part, attachment or accessory damaged by misuse, neglect, fire, exposure to severe environmental or chemical conditions, acidic environment, improper maintenance, accident, crash, or force majeure such as natural disaster, lightning, earthquake, windstorm, hail, flood, war or riot;

(c) any vehicle, chassis or component, part, attachment or accessory that has been repaired, altered or assembled in any way by any person or entity other than Pierce which, in the sole judgment of Pierce, adversely affects the performance, stability or purpose for which it was manufactured; or

(d) products or parts which may in the ordinary course wear out and have to be replaced during the warranty period, including, but not limited to, tires, fluids, gaskets and light bulbs. Pierce assumes no responsibility for the assembly of its parts or subassemblies into finishing products or vehicles unless the assembly is performed by Pierce.

The original purchaser may void this warranty in part or in its entirety if the product is repaired or replaced (a) without prior written approval of the Pierce Customer Service Department; or (b) at a facility which has not been approved by Pierce as to technical capability. Any repairs, modifications, alterations or aftermarket parts added after manufacture without the authorization of Pierce may void this warranty.

2. DISCLAIMERS OF WARRANTIES

THE WARRANTY SET FORTH IN PARAGRAPH 1 IS THE SOLE AND EXCLUSIVE WARRANTY GIVEN BY PIERCE. PIERCE HEREBY DISCLAIMS AND EXCLUDES ALL OTHER WARRANTIES, WHETHER EXPRESS, IMPLIED OR STATUTORY, INCLUDING WITHOUT LIMITATION ANY WARRANTY OF MERCHANTABILITY, ANY WARRANTY OF FITNESS FOR A PARTICULAR PURPOSE, AND ANY WARRANTIES ARISING FROM COURSE OF DEALING OR USAGE OF TRADE.

3. BUYER'S EXCLUSIVE REMEDY

If the product fails to conform to the warranty set forth in paragraph 1 during the warranty period, and such nonconformity is not due to misuse, neglect, accident or improper maintenance, Buyer must notify Pierce within the time period specified in paragraph 1, and shall make the product available for inspection by Pierce or its designated agent. At the request of Pierce, any allegedly defective product shall be returned to Pierce by Buyer for examination and/or repair. Buyer shall be responsible for the cost of such transportation, and for risk of loss of or damage to the product during transportation. Within a reasonable time, Pierce shall repair or replace (at Pierce's option and expense) any nonconforming or defective parts. Repair or replacement shall be made only by a facility approved in advance in writing by Pierce. THIS REMEDY SHALL BE THE EXCLUSIVE AND SOLE REMEDY FOR ANY BREACH OF WARRANTY.

4. EXCLUSION OF CONSEQUENTIAL AND INCIDENTAL DAMAGES

Notwithstanding anything to the contrary herein or in any agreement between Pierce and Buyer, IN NO EVENT SHALL PIERCE BE LIABLE FOR ANY CONSEQUENTIAL, INCIDENTAL, SPECIAL, INDIRECT, OR PUNITIVE DAMAGES WHATSOEVER, WHETHER ARISING OUT OF BREACH OF CONTRACT, WARRANTY, TORT (INCLUDING NEGLIGENCE AND STRICT LIABILITY) OR OTHER THEORY OF LAW OR EQUITY, WITH RESPECT TO VEHICLES OR OTHER PRODUCTS SOLD BY PIERCE, OR THEIR OPERATION OR FAILURE TO OPERATE, OR ANY DEFECTS THEREIN, OR ANY UNDERTAKINGS, ACTS OR OMISSIONS RELATED THERETO, REGARDLESS OF WHETHER PIERCE HAS BEEN INFORMED OF THE POSSIBILITY OF ANY SUCH DAMAGES. Without limiting the generality of the foregoing, Pierce specifically disclaims any liability for property or personal injury damages, penalties, damages for lost profits or revenues, loss of vehicles or products or any associated equipment, cost of substitute vehicles or products, down-time, delay damages, any other types of economic loss, or for any claims by any third party for any such damages.

Note: Any Surety Bond, if a part of the sale of the vehicle as to which this limited warranty is provided, applies only to this Pierce Basic One Year Limited Warranty for such vehicle, and not to other warranties made by Pierce in a separate document (if any) or to the warranties (if any) made by any manufacturer (other than Pierce) of any part, component, attachment or accessory that is incorporated into or attached to the vehicle.



Fire and Rescue Apparatus

Three (3) Year Material and Workmanship Goldstar® Gold Leaf Lamination

Limited Warranty

1. LIMITED WARRANTY

Subject to the limitations and exclusions set forth below, Pierce Manufacturing provides the following warranty to the Buyer:

Coverage:	Each Goldstar® gold leaf lamination shall be free from defects in material and workmanship.
Warranty Begins:	The date of the original purchase invoice (issued when the product ships from the factory).
Warranty Period Ends After:	Three (3) Years
Conditions and Exclusions: See Also Paragraphs 2 thru 4	This warranty does not cover damage from lack of maintenance and cleaning (proper cleaning and maintenance procedures are detailed in the Pierce operation and maintenance manual).

Notwithstanding anything to the contrary herein, Pierce makes no warranty whatsoever as to:

(a) any integral parts, components, attachments or trade accessories of or to the product that are not manufactured by Pierce, including but not limited to engines, transmissions, drivelines, axles, water pumps and generators; with respect to all such parts, components, attachments and accessories, Pierce shall assign to Buyer the applicable warranties, if any, made by the respective manufacturers thereof;

(b) any vehicle, chassis, or component, part, attachment or accessory damaged by misuse, neglect, fire, exposure to severe environmental or chemical conditions, acidic environment, improper maintenance, accident, crash, or force majeure such as natural disaster, lightning, earthquake, windstorm, hail, flood, war or riot;

(c) any vehicle, chassis or component, part, attachment or accessory that has been repaired, altered or assembled in any way by any person or entity other than Pierce which, in the sole judgment of Pierce, adversely affects the performance, stability or purpose for which it was manufactured; or

(d) products or parts which may in the ordinary course wear out and have to be replaced during the warranty period, including, but not limited to, tires, fluids, gaskets and light bulbs. Pierce assumes no responsibility for the assembly of its parts or subassemblies into finishing products or vehicles unless the assembly is performed by Pierce.

The original purchaser may void this warranty in part or in its entirety if the product is repaired or replaced (a) without prior written approval of the Pierce Customer Service Department; or (b) at a facility which has not been approved by Pierce as to technical capability. Any repairs, modifications, alterations or aftermarket parts added after manufacture without the authorization of Pierce may void this warranty.

2. DISCLAIMERS OF WARRANTIES

THE WARRANTY SET FORTH IN PARAGRAPH 1 IS THE SOLE AND EXCLUSIVE WARRANTY GIVEN BY PIERCE. PIERCE HEREBY DISCLAIMS AND EXCLUDES ALL OTHER WARRANTIES, WHETHER EXPRESS, IMPLIED OR STATUTORY, INCLUDING WITHOUT LIMITATION ANY WARRANTY OF MERCHANTABILITY, ANY WARRANTY OF FITNESS FOR A PARTICULAR PURPOSE, AND ANY WARRANTIES ARISING FROM COURSE OF DEALING OR USAGE OF TRADE.

3. BUYER'S EXCLUSIVE REMEDY.

If the product fails to conform to the warranty set forth in paragraph 1 during the warranty period, and such nonconformity is not due to misuse, neglect, accident or improper maintenance, Buyer must notify Pierce within the time period specified in paragraph 1, and shall make the product available for inspection by Pierce or its designated agent. At the request of Pierce, any allegedly defective product shall be returned to Pierce by Buyer for examination and/or repair. Buyer shall be responsible for the cost of such transportation, and for risk of loss of or damage to the product during transportation. Within a reasonable time, Pierce shall repair or replace (at Pierce's option and expense) any nonconforming or defective parts. Repair or replacement shall be made only by a facility approved in advance in writing by Pierce. THIS REMEDY SHALL BE THE EXCLUSIVE AND SOLE REMEDY FOR ANY BREACH OF WARRANTY.

4. EXCLUSION OF CONSEQUENTIAL AND INCIDENTAL DAMAGES.

Notwithstanding anything to the contrary herein or in any agreement between Pierce and Buyer, IN NO EVENT SHALL PIERCE BE LIABLE FOR ANY CONSEQUENTIAL, INCIDENTAL, SPECIAL, INDIRECT, OR PUNITIVE DAMAGES WHATSOEVER, WHETHER ARISING OUT OF BREACH OF CONTRACT, WARRANTY, TORT (INCLUDING NEGLIGENCE AND STRICT LIABILITY) OR OTHER THEORY OF LAW OR EQUITY, WITH RESPECT TO VEHICLES OR OTHER PRODUCTS SOLD BY PIERCE, OR THEIR OPERATION OR FAILURE TO OPERATE, OR ANY DEFECTS THEREIN, OR ANY UNDERTAKINGS, ACTS OR OMISSIONS RELATED THERETO, REGARDLESS OF WHETHER PIERCE HAS BEEN INFORMED OF THE POSSIBILITY OF ANY SUCH DAMAGES. Without limiting the generality of the foregoing, Pierce specifically disclaims any liability for property or personal injury damages, penalties, damages for lost profits or revenues, loss of vehicles or products or any associated equipment, cost of substitute vehicles or products, down-time, delay damages, any other types of economic loss, or for any claims by any third party for any such damages.

Note: Any Surety Bond, if a part of the sale of the vehicle as to which this limited warranty is provided, applies only to this Pierce Basic One Year Limited Warranty for such vehicle, and not to other warranties made by Pierce in a separate document (if any) or to the warranties (if any) made by any manufacturer (other than Pierce) of any part, component, attachment or accessory that is incorporated into or attached to the vehicle.

This limited warranty shall apply only if the product is properly maintained in accordance with Pierce's maintenance instructions and manuals and is used in service which is normal to the particular model. Normal service means service which does not subject the product to stresses or impacts greater than normally result from careful use. If the Buyer discovers a defect or nonconformity, it must notify Pierce in writing within thirty (30) days after the date of discovery, but in any event prior to the expiration of the warranty period. THIS LIMITED WARRANTY MAY NOT BE ASSIGNED OR OTHERWISE TRANSFERRED BY THE BUYER TO ANY SUBSEQUENT USER OR PURCHASER OR TO ANY OTHER PERSON OR ENTITY.



Fire and Rescue Apparatus

Twenty (20) Year Structural Integrity

Pierce Aerial Device

Limited Warranty

1. LIMITED WARRANTY

Subject to the limitations and exclusions set forth below, Pierce Manufacturing provides the following warranty to the Buyer.

Coverage:	Each new Pierce Aerial Device shall be free from defects in material and workmanship. Aerial Device Models Covered by this warranty include: Aerial Platforms Aerial Ladders SkyBoom
Warranty Begins:	The date of the original purchase invoice (issued when the product ships from the factory).
Warranty Period Ends After:	Twenty (20) Years - or - 100,000 Miles
Conditions and Exclusions: See Also Paragraphs 2 thru 4	This warranty applies only to the torque box, turntable, aerial sections and other structural components of the aerial device, as identified in the Pierce specifications for the aerial device. This warranty shall be void if, or to the extent that the aerial device is not maintained in strict compliance with NFPA Standard 1911 in effect at time of sale, including such periodic inspections and testing by qualified third parties as are required by that Standard as it may be in effect from time to time. Proof of such compliance shall accompany any claims under this warranty. Third party testing agencies known to Pierce to be qualified for such purposes may be obtained from the Pierce Customer Service Department This warranty does not apply to damage caused by corrosion.

This limited warranty shall apply only if the product is properly maintained in accordance with Pierce's maintenance instructions and manuals and is used in service which is normal to the particular model. Normal service means service which does not subject the product to stresses or impacts greater than normally result from careful use. If the Buyer discovers a defect or nonconformity, it must notify Pierce in writing within thirty (30) days after the date of discovery, but in any event prior to the expiration of the warranty period. THIS LIMITED WARRANTY MAY NOT BE ASSIGNED OR OTHERWISE TRANSFERRED BY THE BUYER TO ANY SUBSEQUENT USER OR PURCHASER OR TO ANY OTHER PERSON OR ENTITY.

Notwithstanding anything to the contrary herein, Pierce makes no warranty whatsoever as to:

- (a) any integral parts, components, attachments or trade accessories of or to the product that are not manufactured by Pierce, including but not limited to engines, transmissions, drivelines, axles, water pumps and generators; with respect to all such parts, components, attachments and accessories, Pierce shall assign to Buyer the applicable warranties, if any, made by the respective manufacturers thereof;
- (b) any vehicle, chassis, or component, part, attachment or accessory damaged by misuse, neglect, fire, exposure to severe environmental or chemical conditions, acidic environment, improper maintenance, accident, crash, or force majeure such as natural disaster, lightning, earthquake, windstorm, hail, flood, war or riot;
- (c) any vehicle, chassis or component, part, attachment or accessory that has been repaired, altered or assembled in any way by any person or entity other than Pierce which, in the sole judgment of Pierce, adversely affects the performance, stability or purpose for which it was manufactured; or
- (d) products or parts which may in the ordinary course wear out and have to be replaced during the warranty period, including, but not limited to, tires, fluids, gaskets and light bulbs. Pierce assumes no responsibility for the assembly of its parts or subassemblies into finishing products or vehicles unless the assembly is performed by Pierce.

The original purchaser may void this warranty in part or in its entirety if the product is repaired or replaced (a) without prior written approval of the Pierce Customer Service Department; or (b) at a facility which has not been approved by Pierce as to technical capability. Any repairs, modifications, alterations or aftermarket parts added after manufacture without the authorization of Pierce may void this warranty.

2. DISCLAIMERS OF WARRANTIES

THE WARRANTY SET FORTH IN PARAGRAPH 1 IS THE SOLE AND EXCLUSIVE WARRANTY GIVEN BY PIERCE. PIERCE HEREBY DISCLAIMS AND EXCLUDES ALL OTHER WARRANTIES, WHETHER EXPRESS, IMPLIED OR STATUTORY, INCLUDING WITHOUT LIMITATION ANY WARRANTY OF MERCHANTABILITY, ANY WARRANTY OF FITNESS FOR A PARTICULAR PURPOSE, AND ANY WARRANTIES ARISING FROM COURSE OF DEALING OR USAGE OF TRADE.

3. BUYER'S EXCLUSIVE REMEDY.

If the product fails to conform to the warranty set forth in paragraph 1 during the warranty period, and such nonconformity is not due to misuse, neglect, accident or improper maintenance, Buyer must notify Pierce within the time period specified in paragraph 1, and shall make the product available for inspection by Pierce or its designated agent. At the request of Pierce, any allegedly defective product shall be returned to Pierce by Buyer for examination and/or repair. Buyer shall be responsible for the cost of such transportation, and for risk of loss of or damage to the product during transportation. Within a reasonable time, Pierce shall repair or replace (at Pierce's option and expense) any nonconforming or defective parts. Repair or replacement shall be made only by a facility approved in advance in writing by Pierce. THIS REMEDY SHALL BE THE EXCLUSIVE AND SOLE REMEDY FOR ANY BREACH OF WARRANTY.

4. EXCLUSION OF CONSEQUENTIAL AND INCIDENTAL DAMAGES.

Notwithstanding anything to the contrary herein or in any agreement between Pierce and Buyer, IN NO EVENT SHALL PIERCE BE LIABLE FOR ANY CONSEQUENTIAL, INCIDENTAL, SPECIAL, INDIRECT, OR PUNITIVE DAMAGES WHATSOEVER, WHETHER ARISING OUT OF BREACH OF CONTRACT, WARRANTY, TORT (INCLUDING NEGLIGENCE AND STRICT LIABILITY) OR OTHER THEORY OF LAW OR EQUITY, WITH RESPECT TO VEHICLES OR OTHER PRODUCTS SOLD BY PIERCE, OR THEIR OPERATION OR FAILURE TO OPERATE, OR ANY DEFECTS THEREIN, OR ANY UNDERTAKINGS, ACTS OR OMISSIONS RELATED THERETO, REGARDLESS OF WHETHER PIERCE HAS BEEN INFORMED OF THE POSSIBILITY OF ANY SUCH DAMAGES. Without limiting the generality of the foregoing, Pierce specifically disclaims any liability for property or personal injury damages, penalties, damages for lost profits or revenues, loss of vehicles or products or any associated equipment, cost of substitute vehicles or products, down-time, delay damages, any other types of economic loss, or for any claims by any third party for any such damages.

Note: Any Surety Bond, if a part of the sale of the vehicle as to which this limited warranty is provided, applies only to this Pierce Basic One Year Limited Warranty for such vehicle, and not to other warranties made by Pierce in a separate document (if any) or to the warranties (if any) made by any manufacturer (other than Pierce) of any part, component, attachment or accessory that is incorporated into or attached to the vehicle.



Fire and Rescue Apparatus

Ten (10) Year Pro-Rated Paint and Corrosion

Cab

Limited Warranty

1. LIMITED WARRANTY

Subject to the limitations and exclusions set forth below, Pierce Manufacturing provides the following warranty to the Buyer:

Coverage:	Exterior surfaces of the cab painted by Pierce shall be free from blistering, peeling, corrosion or any other adhesion defect caused by defective manufacturing methods or paint material selection.
Warranty Begins:	The date of the original purchase invoice (issued when the product ships from the factory).
Warranty Period Ends After:	Ten (10) Years
Conditions and Exclusions:	<p>This limited warranty is applicable to the vehicle in the following percentage costs of warranty repair, if any:</p> <p>Topcoat Durability & Appearance: Gloss, Color Retention & Cracking 0-72 months 100% 73-96 months 50% 97-120 months 25%</p> <p>Integrity of Coating System: Adhesion, Blistering/Bubbling 0-36 months 100% 37-84 months 50% 85-120 months 25%</p> <p>Corrosion: Dissimilar Metal and Crevice 0-36 months 100% 37-48 months 50% 49-72 months 25% 73-120 months 10%</p> <p>Corrosion Perforation 0-120 months 100%</p> <p>This limited warranty applies only to exterior paint. Paint on the vehicle's interior is warranted only under the Pierce Basic One Year Limited Warranty.</p> <p>Items not covered by this warranty include: (a) Damage from lack of maintenance and cleaning (proper cleaning and maintenance procedures are detailed in the Pierce operation and maintenance manual). (b) UV paint fade. (c) Any cab not manufactured by Pierce.</p>
See Also Paragraphs 2 thru 4	

Notwithstanding anything to the contrary herein, Pierce makes no warranty whatsoever as to:

(a) any integral parts, components, attachments or trade accessories of or to the product that are not manufactured by Pierce, including but not limited to engines, transmissions, drivelines, axles, water pumps and generators; with respect to all such parts, components, attachments and accessories, Pierce shall assign to Buyer the applicable warranties, if any, made by the respective manufacturers thereof;

(b) any vehicle, chassis, or component, part, attachment or accessory damaged by misuse, neglect, fire, exposure to severe environmental or chemical conditions, acidic environment, improper maintenance, accident, crash, or force majeure such as natural disaster, lightning, earthquake, windstorm, hail, flood, war or riot;

(c) any vehicle, chassis or component, part, attachment or accessory that has been repaired, altered or assembled in any way by any person or entity other than Pierce which, in the sole judgment of Pierce, adversely affects the performance, stability or purpose for which it was manufactured; or

(d) products or parts which may in the ordinary course wear out and have to be replaced during the warranty period, including, but not limited to, tires, fluids, gaskets and light bulbs. Pierce assumes no responsibility for the assembly of its parts or subassemblies into finishing products or vehicles unless the assembly is performed by Pierce.

The original purchaser may void this warranty in part or in its entirety if the product is repaired or replaced (a) without prior written approval of the Pierce Customer Service Department; or (b) at a facility which has not been approved by Pierce as to technical capability. Any repairs, modifications, alterations or aftermarket parts added after manufacture without the authorization of Pierce may void this warranty.

2. DISCLAIMERS OF WARRANTIES

THE WARRANTY SET FORTH IN PARAGRAPH 1 IS THE SOLE AND EXCLUSIVE WARRANTY GIVEN BY PIERCE. PIERCE HEREBY DISCLAIMS AND EXCLUDES ALL OTHER WARRANTIES, WHETHER EXPRESS, IMPLIED OR STATUTORY, INCLUDING WITHOUT LIMITATION ANY WARRANTY OF MERCHANTABILITY, ANY WARRANTY OF FITNESS FOR A PARTICULAR PURPOSE, AND ANY WARRANTIES ARISING FROM COURSE OF DEALING OR USAGE OF TRADE.

3. BUYER'S EXCLUSIVE REMEDY

If the product fails to conform to the warranty set forth in paragraph 1 during the warranty period, and such nonconformity is not due to misuse, neglect, accident or improper maintenance, Buyer must notify Pierce within the time period specified in paragraph 1, and shall make the product available for inspection by Pierce or its designated agent. At the request of Pierce, any allegedly defective product shall be returned to Pierce by Buyer for examination and/or repair. Buyer shall be responsible for the cost of such transportation, and for risk of loss of or damage to the product during transportation. Within a reasonable time, Pierce shall repair or replace (at Pierce's option and expense) any nonconforming or defective parts. Repair or replacement shall be made only by a facility approved in advance in writing by Pierce. THIS REMEDY SHALL BE THE EXCLUSIVE AND SOLE REMEDY FOR ANY BREACH OF WARRANTY.

4. EXCLUSION OF CONSEQUENTIAL AND INCIDENTAL DAMAGES

Notwithstanding anything to the contrary herein or in any agreement between Pierce and Buyer, IN NO EVENT SHALL PIERCE BE LIABLE FOR ANY CONSEQUENTIAL, INCIDENTAL, SPECIAL, INDIRECT, OR PUNITIVE DAMAGES WHATSOEVER, WHETHER ARISING OUT OF BREACH OF CONTRACT, WARRANTY, TORT (INCLUDING NEGLIGENCE AND STRICT LIABILITY) OR OTHER THEORY OF LAW OR EQUITY, WITH RESPECT TO VEHICLES OR OTHER PRODUCTS SOLD BY PIERCE, OR THEIR OPERATION OR FAILURE TO OPERATE, OR ANY DEFECTS THEREIN, OR ANY UNDERTAKINGS, ACTS OR OMISSIONS RELATED THERETO, REGARDLESS OF WHETHER PIERCE HAS BEEN INFORMED OF THE POSSIBILITY OF ANY SUCH DAMAGES. Without limiting the generality of the foregoing, Pierce specifically disclaims any liability for property or personal injury damages, penalties, damages for lost profits or revenues, loss of vehicles or products or any associated equipment, cost of substitute vehicles or products, down-time, delay damages, any other types of economic loss, or for any claims by any third party for any such damages.

Note: Any Surety Bond, if a part of the sale of the vehicle as to which this limited warranty is provided, applies only to this Pierce Basic One Year Limited Warranty for such vehicle, and not to other warranties made by Pierce in a separate document (if any) or to the warranties (if any) made by any manufacturer (other than Pierce) of any part, component, attachment or accessory that is incorporated into or attached to the vehicle.

This limited warranty shall apply only if the product is properly maintained in accordance with Pierce's maintenance instructions and manuals and is used in service which is normal to the particular model. Normal service means service which does not subject the product to stresses or impacts greater than normally result from careful use. If the Buyer discovers a defect or nonconformity, it must notify Pierce in writing within thirty (30) days after the date of discovery, but in any event prior to the expiration of the warranty period. THIS LIMITED WARRANTY MAY NOT BE ASSIGNED OR OTHERWISE TRANSFERRED BY THE BUYER TO ANY SUBSEQUENT USER OR PURCHASER OR TO ANY OTHER PERSON OR ENTITY.



Fire and Rescue Apparatus

Ten (10) Year Pro-Rated Paint and Corrosion

Custom Body

Limited Warranty

1. LIMITED WARRANTY

Subject to the limitations and exclusions set forth below, Pierce Manufacturing provides the following warranty to the Buyer:

Coverage:	Exterior surfaces of the body shall be free from blistering, peeling, corrosion or any other adhesion defect caused by defective manufacturing methods or paint material selection.
Warranty Begins:	The date of the original purchase invoice (issued when the product ships from the factory).
Warranty Period Ends After:	Ten (10) Years
Conditions and Exclusions:	<p>This limited warranty is applicable to the vehicle in the following percentage costs of warranty repair, if any:</p> <p>Topcoat Durability & Appearance: Gloss, Color Retention & Cracking 0-72 months 100% 73-96 months 50% 97-120 months 25%</p> <p>Integrity of Coating System: Adhesion, Blistering/Bubbling 0-36 months 100% 37-84 months 50% 85-120 months 25%</p> <p>Corrosion: Dissimilar Metal and Crevice 0-36 months 100% 37-48 months 50% 49-72 months 25% 73-120 months 10%</p> <p>Corrosion Perforation 0-120 months 100%</p> <p>This limited warranty applies only to exterior paint. Paint on the vehicle's interior is warranted only under the Pierce Basic One Year Limited Warranty.</p> <p>Items not covered by this warranty include: (a) Damage from lack of maintenance and cleaning (proper cleaning and maintenance procedures are detailed in the Pierce operation and maintenance manual). (b) UV paint fade. (c) Any cab not manufactured by Pierce.</p>
See Also Paragraphs 2 thru 4	

This limited warranty shall apply only if the product is properly maintained in accordance with Pierce's maintenance instructions and manuals and is used in service which is normal to the particular model. Normal service means service which does not subject the product to stresses or impacts greater than normally result from careful use. If the Buyer discovers a defect or nonconformity, it must notify Pierce in writing within thirty (30) days after the date of discovery, but in any event prior to the expiration of the warranty period. THIS LIMITED WARRANTY MAY NOT BE ASSIGNED OR OTHERWISE TRANSFERRED BY THE BUYER TO ANY SUBSEQUENT USER OR PURCHASER OR TO ANY OTHER PERSON OR ENTITY.

Notwithstanding anything to the contrary herein, Pierce makes no warranty whatsoever as to:

(a) any integral parts, components, attachments or trade accessories of or to the product that are not manufactured by Pierce, including but not limited to engines, transmissions, drivelines, axles, water pumps and generators; with respect to all such parts, components, attachments and accessories, Pierce shall assign to Buyer the applicable warranties, if any, made by the respective manufacturers thereof;

(b) any vehicle, chassis, or component, part, attachment or accessory damaged by misuse, neglect, fire, exposure to severe environmental or chemical conditions, acidic environment, improper maintenance, accident, crash, or force majeure such as natural disaster, lightning, earthquake, windstorm, hail, flood, war or riot;

(c) any vehicle, chassis or component, part, attachment or accessory that has been repaired, altered or assembled in any way by any person or entity other than Pierce which, in the sole judgment of Pierce, adversely affects the performance, stability or purpose for which it was manufactured; or

(d) products or parts which may in the ordinary course wear out and have to be replaced during the warranty period, including, but not limited to, tires, fluids, gaskets and light bulbs. Pierce assumes no responsibility for the assembly of its parts or subassemblies into finishing products or vehicles unless the assembly is performed by Pierce.

The original purchaser may void this warranty in part or in its entirety if the product is repaired or replaced (a) without prior written approval of the Pierce Customer Service Department; or (b) at a facility which has not been approved by Pierce as to technical capability. Any repairs, modifications, alterations or aftermarket parts added after manufacture without the authorization of Pierce may void this warranty.

2. DISCLAIMERS OF WARRANTIES

THE WARRANTY SET FORTH IN PARAGRAPH 1 IS THE SOLE AND EXCLUSIVE WARRANTY GIVEN BY PIERCE. PIERCE HEREBY DISCLAIMS AND EXCLUDES ALL OTHER WARRANTIES, WHETHER EXPRESS, IMPLIED OR STATUTORY, INCLUDING WITHOUT LIMITATION ANY WARRANTY OF MERCHANTABILITY, ANY WARRANTY OF FITNESS FOR A PARTICULAR PURPOSE, AND ANY WARRANTIES ARISING FROM COURSE OF DEALING OR USAGE OF TRADE.

3. BUYER'S EXCLUSIVE REMEDY

If the product fails to conform to the warranty set forth in paragraph 1 during the warranty period, and such nonconformity is not due to misuse, neglect, accident or improper maintenance, Buyer must notify Pierce within the time period specified in paragraph 1, and shall make the product available for inspection by Pierce or its designated agent. At the request of Pierce, any allegedly defective product shall be returned to Pierce by Buyer for examination and/or repair. Buyer shall be responsible for the cost of such transportation, and for risk of loss of or damage to the product during transportation. Within a reasonable time, Pierce shall repair or replace (at Pierce's option and expense) any nonconforming or defective parts. Repair or replacement shall be made only by a facility approved in advance in writing by Pierce. THIS REMEDY SHALL BE THE EXCLUSIVE AND SOLE REMEDY FOR ANY BREACH OF WARRANTY.

4. EXCLUSION OF CONSEQUENTIAL AND INCIDENTAL DAMAGES

Notwithstanding anything to the contrary herein or in any agreement between Pierce and Buyer, IN NO EVENT SHALL PIERCE BE LIABLE FOR ANY CONSEQUENTIAL, INCIDENTAL, SPECIAL, INDIRECT, OR PUNITIVE DAMAGES WHATSOEVER, WHETHER ARISING OUT OF BREACH OF CONTRACT, WARRANTY, TORT (INCLUDING NEGLIGENCE AND STRICT LIABILITY) OR OTHER THEORY OF LAW OR EQUITY, WITH RESPECT TO VEHICLES OR OTHER PRODUCTS SOLD BY PIERCE, OR THEIR OPERATION OR FAILURE TO OPERATE, OR ANY DEFECTS THEREIN, OR ANY UNDERTAKINGS, ACTS OR OMISSIONS RELATED THERETO, REGARDLESS OF WHETHER PIERCE HAS BEEN INFORMED OF THE POSSIBILITY OF ANY SUCH DAMAGES. Without limiting the generality of the foregoing, Pierce specifically disclaims any liability for property or personal injury damages, penalties, damages for lost profits or revenues, loss of vehicles or products or any associated equipment, cost of substitute vehicles or products, down-time, delay damages, any other types of economic loss, or for any claims by any third party for any such damages.

Note. Any Surety Bond, if a part of the sale of the vehicle as to which this limited warranty is provided, applies only to this Pierce Basic One Year Limited Warranty for such vehicle, and not to other warranties made by Pierce in a separate document (if any) or to the warranties (if any) made by any manufacturer (other than Pierce) of any part, component, attachment or accessory that is incorporated into or attached to the vehicle.



Fire and Rescue Apparatus

Three (3) Year Material and Workmanship

Meritor Axles

Limited Warranty

1. LIMITED WARRANTY

Subject to the limitations and exclusions set forth below, Pierce Manufacturing provides the following warranty to the Buyer:

Coverage:	The Meritor axle shall be covered by Meritor as indicated in the attached Meritor warranty coverage description
Warranty Begins:	The date of the original purchase invoice (issued when the product ships from the factory).
Warranty Period Ends After:	Three (3) Year
Conditions and Exclusions: See Also Paragraphs 2 thru 4	The exclusions listed in the attached Meritor warranty description shall apply.

Notwithstanding anything to the contrary herein, Pierce makes no warranty whatsoever as to:

(a) any integral parts, components, attachments or trade accessories of or to the product that are not manufactured by Pierce, including but not limited to engines, transmissions, drivelines, axles, water pumps and generators; with respect to all such parts, components, attachments and accessories, Pierce shall assign to Buyer the applicable warranties, if any, made by the respective manufacturers thereof;

(b) any vehicle, chassis, or component, part, attachment or accessory damaged by misuse, neglect, fire, exposure to severe environmental or chemical conditions, acidic environment, improper maintenance, accident, crash, or force majeure such as natural disaster, lightning, earthquake, windstorm, hail, flood, war or riot;

(c) any vehicle, chassis or component, part, attachment or accessory that has been repaired, altered or assembled in any way by any person or entity other than Pierce which, in the sole judgment of Pierce, adversely affects the performance, stability or purpose for which it was manufactured; or

(d) products or parts which may in the ordinary course wear out and have to be replaced during the warranty period, including, but not limited to, tires, fluids, gaskets and light bulbs. Pierce assumes no responsibility for the assembly of its parts or subassemblies into finishing products or vehicles unless the assembly is performed by Pierce.

The original purchaser may void this warranty in part or in its entirety if the product is repaired or replaced (a) without prior written approval of the Pierce Customer Service Department; or (b) at a facility which has not been approved by Pierce as to technical capability. Any repairs, modifications, alterations or aftermarket parts added after manufacture without the authorization of Pierce may void this warranty.

2. DISCLAIMERS OF WARRANTIES

THE WARRANTY SET FORTH IN PARAGRAPH 1 IS THE SOLE AND EXCLUSIVE WARRANTY GIVEN BY PIERCE. PIERCE HEREBY DISCLAIMS AND EXCLUDES ALL OTHER WARRANTIES, WHETHER EXPRESS, IMPLIED OR STATUTORY, INCLUDING WITHOUT LIMITATION ANY WARRANTY OF MERCHANTABILITY, ANY WARRANTY OF FITNESS FOR A PARTICULAR PURPOSE, AND ANY WARRANTIES ARISING FROM COURSE OF DEALING OR USAGE OF TRADE.

3. BUYER'S EXCLUSIVE REMEDY

If the product fails to conform to the warranty set forth in paragraph 1 during the warranty period, and such nonconformity is not due to misuse, neglect, accident or improper maintenance, Buyer must notify Pierce within the time period specified in paragraph 1, and shall make the product available for inspection by Pierce or its designated agent. At the request of Pierce, any allegedly defective product shall be returned to Pierce by Buyer for examination and/or repair. Buyer shall be responsible for the cost of such transportation, and for risk of loss of or damage to the product during transportation. Within a reasonable time, Pierce shall repair or replace (at Pierce's option and expense) any nonconforming or defective parts. Repair or replacement shall be made only by a facility approved in advance in writing by Pierce. THIS REMEDY SHALL BE THE EXCLUSIVE AND SOLE REMEDY FOR ANY BREACH OF WARRANTY.

4. EXCLUSION OF CONSEQUENTIAL AND INCIDENTAL DAMAGES

Notwithstanding anything to the contrary herein or in any agreement between Pierce and Buyer, IN NO EVENT SHALL PIERCE BE LIABLE FOR ANY CONSEQUENTIAL, INCIDENTAL, SPECIAL, INDIRECT, OR PUNITIVE DAMAGES WHATSOEVER, WHETHER ARISING OUT OF BREACH OF CONTRACT, WARRANTY, TORT (INCLUDING NEGLIGENCE AND STRICT LIABILITY) OR OTHER THEORY OF LAW OR EQUITY, WITH RESPECT TO VEHICLES OR OTHER PRODUCTS SOLD BY PIERCE, OR THEIR OPERATION OR FAILURE TO OPERATE, OR ANY DEFECTS THEREIN, OR ANY UNDERTAKINGS, ACTS OR OMISSIONS RELATED THERETO, REGARDLESS OF WHETHER PIERCE HAS BEEN INFORMED OF THE POSSIBILITY OF ANY SUCH DAMAGES. Without limiting the generality of the foregoing, Pierce specifically disclaims any liability for property or personal injury damages, penalties, damages for lost profits or revenues, loss of vehicles or products or any associated equipment, cost of substitute vehicles or products, down-time, delay damages, any other types of economic loss, or for any claims by any third party for any such damages.

Note: Any Surety Bond, if a part of the sale of the vehicle as to which this limited warranty is provided, applies only to this Pierce Basic One Year Limited Warranty for such vehicle, and not to other warranties made by Pierce in a separate document (if any) or to the warranties (if any) made by any manufacturer (other than Pierce) of any part, component, attachment or accessory that is incorporated into or attached to the vehicle.

This limited warranty shall apply only if the product is properly maintained in accordance with Pierce's maintenance instructions and manuals and is used in service which is normal to the particular model. Normal service means service which does not subject the product to stresses or impacts greater than normally result from careful use. If the Buyer discovers a defect or nonconformity, it must notify Pierce in writing within thirty (30) days after the date of discovery, but in any event prior to the expiration of the warranty period. THIS LIMITED WARRANTY MAY NOT BE ASSIGNED OR OTHERWISE TRANSFERRED BY THE BUYER TO ANY SUBSEQUENT USER OR PURCHASER OR TO ANY OTHER PERSON OR ENTITY.



Fire and Rescue Apparatus

Five (5) Year Material and Workmanship Aerial Hydraulic System Components

Three (3) Year Material and Workmanship Aerial Hydraulic System Seals

Limited Warranty

1. LIMITED WARRANTY

Subject to the limitations and exclusions set forth below, Pierce Manufacturing provides the following warranty to the Buyer:

Coverage:	The aerial hydraulic system components and seals shall be free from component or structural failures caused by defects in material and/or workmanship.
Warranty Begins:	The date of the original purchase invoice (issued when the product ships from the factory).
Warranty Period Ends After:	Five (5) Years and Three (3) Years
Conditions and Exclusions:	Pierce's obligation under this warranty is limited to repairing or replacing without charge, as Pierce may elect, the hydraulic lines, fittings, valves, seals, cylinders, filters, pumps, hydraulic motors, rotary actuators, or components which Pierce determines to have failed due to defective material and workmanship.
See Also Paragraphs 2 thru 4	This warranty shall not apply unless the aerial device is inspected in accordance with NFPA 1911 Standard for Inspection, Maintenance, Testing, and Retirement of In-Service Automotive Fire Apparatus and the applicable Pierce Operator and Maintenance Manuals.

Notwithstanding anything to the contrary herein, Pierce makes no warranty whatsoever as to:

(a) any integral parts, components, attachments or trade accessories of or to the product that are not manufactured by Pierce, including but not limited to engines, transmissions, drivelines, axles, water pumps and generators; with respect to all such parts, components, attachments and accessories, Pierce shall assign to Buyer the applicable warranties, if any, made by the respective manufacturers thereof;

(b) any vehicle, chassis, or component, part, attachment or accessory damaged by misuse, neglect, fire, exposure to severe environmental or chemical conditions, acidic environment, improper maintenance, accident, crash, or force majeure such as natural disaster, lightning, earthquake, windstorm, hail, flood, war or riot;

(c) any vehicle, chassis or component, part, attachment or accessory that has been repaired, altered or assembled in any way by any person or entity other than Pierce which, in the sole judgment of Pierce, adversely affects the performance, stability or purpose for which it was manufactured; or

(d) products or parts which may in the ordinary course wear out and have to be replaced during the warranty period, including, but not limited to, tires, fluids, gaskets and light bulbs. Pierce assumes no responsibility for the assembly of its parts or subassemblies into finishing products or vehicles unless the assembly is performed by Pierce.

The original purchaser may void this warranty in part or in its entirety if the product is repaired or replaced (a) without prior written approval of the Pierce Customer Service Department; or (b) at a facility which has not been approved by Pierce as to technical capability. Any repairs, modifications, alterations or aftermarket parts added after manufacture without the authorization of Pierce may void this warranty.

2. DISCLAIMERS OF WARRANTIES

THE WARRANTY SET FORTH IN PARAGRAPH 1 IS THE SOLE AND EXCLUSIVE WARRANTY GIVEN BY PIERCE. PIERCE HEREBY DISCLAIMS AND EXCLUDES ALL OTHER WARRANTIES, WHETHER EXPRESS, IMPLIED OR STATUTORY, INCLUDING WITHOUT LIMITATION ANY WARRANTY OF MERCHANTABILITY, ANY WARRANTY OF FITNESS FOR A PARTICULAR PURPOSE, AND ANY WARRANTIES ARISING FROM COURSE OF DEALING OR USAGE OF TRADE.

3. BUYER'S EXCLUSIVE REMEDY

If the product fails to conform to the warranty set forth in paragraph 1 during the warranty period, and such nonconformity is not due to misuse, neglect, accident or improper maintenance, Buyer must notify Pierce within the time period specified in paragraph 1, and shall make the product available for inspection by Pierce or its designated agent. At the request of Pierce, any allegedly defective product shall be returned to Pierce by Buyer for examination and/or repair. Buyer shall be responsible for the cost of such transportation, and for risk of loss of or damage to the product during transportation. Within a reasonable time, Pierce shall repair or replace (at Pierce's option and expense) any nonconforming or defective parts. Repair or replacement shall be made only by a facility approved in advance in writing by Pierce. THIS REMEDY SHALL BE THE EXCLUSIVE AND SOLE REMEDY FOR ANY BREACH OF WARRANTY.

4. EXCLUSION OF CONSEQUENTIAL AND INCIDENTAL DAMAGES

Notwithstanding anything to the contrary herein or in any agreement between Pierce and Buyer, IN NO EVENT SHALL PIERCE BE LIABLE FOR ANY CONSEQUENTIAL, INCIDENTAL, SPECIAL, INDIRECT, OR PUNITIVE DAMAGES WHATSOEVER, WHETHER ARISING OUT OF BREACH OF CONTRACT, WARRANTY, TORT (INCLUDING NEGLIGENCE AND STRICT LIABILITY) OR OTHER THEORY OF LAW OR EQUITY, WITH RESPECT TO VEHICLES OR OTHER PRODUCTS SOLD BY PIERCE, OR THEIR OPERATION OR FAILURE TO OPERATE, OR ANY DEFECTS THEREIN, OR ANY UNDERTAKINGS, ACTS OR OMISSIONS RELATED THERETO, REGARDLESS OF WHETHER PIERCE HAS BEEN INFORMED OF THE POSSIBILITY OF ANY SUCH DAMAGES. Without limiting the generality of the foregoing, Pierce specifically disclaims any liability for property or personal injury damages, penalties, damages for lost profits or revenues, loss of vehicles or products or any associated equipment, cost of substitute vehicles or products, down-time, delay damages, any other types of economic loss, or for any claims by any third party for any such damages.

Note: Any Surety Bond, if a part of the sale of the vehicle as to which this limited warranty is provided, applies only to this Pierce Basic One Year Limited Warranty for such vehicle, and not to other warranties made by Pierce in a separate document (if any) or to the warranties (if any) made by any manufacturer (other than Pierce) of any part, component, attachment or accessory that is incorporated into or attached to the vehicle.

This limited warranty shall apply only if the product is properly maintained in accordance with Pierce's maintenance instructions and manuals and is used in service which is normal to the particular model. Normal service means service which does not subject the product to stresses or impacts greater than normally result from careful use. If the Buyer discovers a defect or nonconformity, it must notify Pierce in writing within thirty (30) days after the date of discovery, but in any event prior to the expiration of the warranty period. THIS LIMITED WARRANTY MAY NOT BE ASSIGNED OR OTHERWISE TRANSFERRED BY THE BUYER TO ANY SUBSEQUENT USER OR PURCHASER OR TO ANY OTHER PERSON OR ENTITY.



Fire and Rescue Apparatus

Three (3) Year Material and Workmanship Meritor Wabco ABS Brake System Limited Warranty

1. LIMITED WARRANTY

Subject to the limitations and exclusions set forth below, Pierce Manufacturing provides the following warranty to the Buyer:

Coverage:	The Meritor Wabco ABS brake system shall be covered by Meritor Wabco as indicated in the attached Meritor Wabco warranty coverage description
Warranty Begins:	The date of the original purchase invoice (issued when the product ships from the factory).
Warranty Period Ends After:	Three (3) Year
Conditions and Exclusions: See Also Paragraphs 2 thru 4	The exclusions listed in the attached Meritor Wabco warranty description shall apply.

This limited warranty shall apply only if the product is properly maintained in accordance with Pierce's maintenance instructions and manuals and is used in service which is normal to the particular model. Normal service means service which does not subject the product to stresses or impacts greater than normally result from careful use. If the Buyer discovers a defect or nonconformity, it must notify Pierce in writing within thirty (30) days after the date of discovery, but in any event prior to the expiration of the warranty period. THIS LIMITED WARRANTY MAY NOT BE ASSIGNED OR OTHERWISE TRANSFERRED BY THE BUYER TO ANY SUBSEQUENT USER OR PURCHASER OR TO ANY OTHER PERSON OR ENTITY.

Notwithstanding anything to the contrary herein, Pierce makes no warranty whatsoever as to:

- (a) any integral parts, components, attachments or trade accessories of or to the product that are not manufactured by Pierce, including but not limited to engines, transmissions, drivelines, axles, water pumps and generators; with respect to all such parts, components, attachments and accessories, Pierce shall assign to Buyer the applicable warranties, if any, made by the respective manufacturers thereof;
- (b) any vehicle, chassis, or component, part, attachment or accessory damaged by misuse, neglect, fire, exposure to severe environmental or chemical conditions, acidic environment, improper maintenance, accident, crash, or force majeure such as natural disaster, lightning, earthquake, windstorm, hail, flood, war or riot;
- (c) any vehicle, chassis or component, part, attachment or accessory that has been repaired, altered or assembled in any way by any person or entity other than Pierce which, in the sole judgment of Pierce, adversely affects the performance, stability or purpose for which it was manufactured; or
- (d) products or parts which may in the ordinary course wear out and have to be replaced during the warranty period, including, but not limited to, tires, fluids, gaskets and light bulbs. Pierce assumes no responsibility for the assembly of its parts or subassemblies into finishing products or vehicles unless the assembly is performed by Pierce.

The original purchaser may void this warranty in part or in its entirety if the product is repaired or replaced (a) without prior written approval of the Pierce Customer Service Department; or (b) at a facility which has not been approved by Pierce as to technical capability. Any repairs, modifications, alterations or aftermarket parts added after manufacture without the authorization of Pierce may void this warranty.

2. DISCLAIMERS OF WARRANTIES

THE WARRANTY SET FORTH IN PARAGRAPH 1 IS THE SOLE AND EXCLUSIVE WARRANTY GIVEN BY PIERCE. PIERCE HEREBY DISCLAIMS AND EXCLUDES ALL OTHER WARRANTIES, WHETHER EXPRESS, IMPLIED OR STATUTORY, INCLUDING WITHOUT LIMITATION ANY WARRANTY OF MERCHANTABILITY, ANY WARRANTY OF FITNESS FOR A PARTICULAR PURPOSE, AND ANY WARRANTIES ARISING FROM COURSE OF DEALING OR USAGE OF TRADE.

3. BUYER'S EXCLUSIVE REMEDY.

If the product fails to conform to the warranty set forth in paragraph 1 during the warranty period, and such nonconformity is not due to misuse, neglect, accident or improper maintenance, Buyer must notify Pierce within the time period specified in paragraph 1, and shall make the product available for inspection by Pierce or its designated agent. At the request of Pierce, any allegedly defective product shall be returned to Pierce by Buyer for examination and/or repair. Buyer shall be responsible for the cost of such transportation, and for risk of loss of or damage to the product during transportation. Within a reasonable time, Pierce shall repair or replace (at Pierce's option and expense) any nonconforming or defective parts. Repair or replacement shall be made only by a facility approved in advance in writing by Pierce. THIS REMEDY SHALL BE THE EXCLUSIVE AND SOLE REMEDY FOR ANY BREACH OF WARRANTY.

4. EXCLUSION OF CONSEQUENTIAL AND INCIDENTAL DAMAGES.

Notwithstanding anything to the contrary herein or in any agreement between Pierce and Buyer, IN NO EVENT SHALL PIERCE BE LIABLE FOR ANY CONSEQUENTIAL, INCIDENTAL, SPECIAL, INDIRECT, OR PUNITIVE DAMAGES WHATSOEVER, WHETHER ARISING OUT OF BREACH OF CONTRACT, WARRANTY, TORT (INCLUDING NEGLIGENCE AND STRICT LIABILITY) OR OTHER THEORY OF LAW OR EQUITY, WITH RESPECT TO VEHICLES OR OTHER PRODUCTS SOLD BY PIERCE, OR THEIR OPERATION OR FAILURE TO OPERATE, OR ANY DEFECTS THEREIN, OR ANY UNDERTAKINGS, ACTS OR OMISSIONS RELATED THERETO, REGARDLESS OF WHETHER PIERCE HAS BEEN INFORMED OF THE POSSIBILITY OF ANY SUCH DAMAGES. Without limiting the generality of the foregoing, Pierce specifically disclaims any liability for property or personal injury damages, penalties, damages for lost profits or revenues, loss of vehicles or products or any associated equipment, cost of substitute vehicles or products, down-time, delay damages, any other types of economic loss, or for any claims by any third party for any such damages.

Note: Any Surety Bond, if a part of the sale of the vehicle as to which this limited warranty is provided, applies only to this Pierce Basic One Year Limited Warranty for such vehicle, and not to other warranties made by Pierce in a separate document (if any) or to the warranties (if any) made by any manufacturer (other than Pierce) of any part, component, attachment or accessory that is incorporated into or attached to the vehicle.



Fire and Rescue Apparatus

Four (4) Year Pro-Rated Paint and Corrosion

Aerial Device

Limited Warranty

1. LIMITED WARRANTY

Subject to the limitations and exclusions set forth below, Pierce Manufacturing provides the following warranty to the Buyer:

Coverage:	Aerial device shall be free from blistering, peeling, corrosion or any other adhesion defect caused by defective manufacturing methods or paint material selection for exterior surfaces.
Warranty Begins:	The date of the original purchase invoice (issued when the product ships from the factory).
Warranty Period Ends After:	Four (4) Years
Conditions and Exclusions: See Also Paragraphs 2 thru 4	<p>This limited warranty is applicable to the vehicle in the following percentage costs of warranty repair, if any:</p> <p>Topcoat Durability & Appearance: Gloss, Color Retention & Cracking 0-24 months 100% 25-48 months 50%</p> <p>Integrity of Coating System: Adhesion, Blistering/Bubbling 0-24 months 100% 25-48 months 50%</p> <p>Corrosion: Dissimilar Metal and Crevice 0-24 months 100% 25-48 months 50%</p> <p>Corrosion Perforation 0-24 months 100% 25-48 months 50%</p> <p>This limited warranty applies only to exterior paint.</p> <p>Items not covered by this warranty include: (a) Damage from lack of maintenance and cleaning (proper cleaning and maintenance procedures are detailed in the Pierce operation and maintenance manual). (b) UV paint fade.</p>

This limited warranty shall apply only if the product is properly maintained in accordance with Pierce's maintenance instructions and manuals and is used in service which is normal to the particular model. Normal service means service which does not subject the product to stresses or impacts greater than normally result from careful use. If the Buyer discovers a defect or nonconformity, it must notify Pierce in writing within thirty (30) days after the date of discovery, but in any event prior to the expiration of the warranty period. THIS LIMITED WARRANTY MAY NOT BE ASSIGNED OR OTHERWISE TRANSFERRED BY THE BUYER TO ANY SUBSEQUENT USER OR PURCHASER OR TO ANY OTHER PERSON OR ENTITY.

Notwithstanding anything to the contrary herein, Pierce makes no warranty whatsoever as to:

(a) any integral parts, components, attachments or trade accessories of or to the product that are not manufactured by Pierce, including but not limited to engines, transmissions, drivelines, axles, water pumps and generators; with respect to all such parts, components, attachments and accessories, Pierce shall assign to Buyer the applicable warranties, if any, made by the respective manufacturers thereof;

(b) any vehicle, chassis, or component, part, attachment or accessory damaged by misuse, neglect, fire, exposure to severe environmental or chemical conditions, acidic environment, improper maintenance, accident, crash, or force majeure such as natural disaster, lightning, earthquake, windstorm, hail, flood, war or riot;

(c) any vehicle, chassis or component, part, attachment or accessory that has been repaired, altered or assembled in any way by any person or entity other than Pierce which, in the sole judgment of Pierce, adversely affects the performance, stability or purpose for which it was manufactured; or

(d) products or parts which may in the ordinary course wear out and have to be replaced during the warranty period, including, but not limited to, tires, fluids, gaskets and light bulbs. Pierce assumes no responsibility for the assembly of its parts or subassemblies into finishing products or vehicles unless the assembly is performed by Pierce.

The original purchaser may void this warranty in part or in its entirety if the product is repaired or replaced (a) without prior written approval of the Pierce Customer Service Department; or (b) at a facility which has not been approved by Pierce as to technical capability. Any repairs, modifications, alterations or aftermarket parts added after manufacture without the authorization of Pierce may void this warranty.

2. DISCLAIMERS OF WARRANTIES

THE WARRANTY SET FORTH IN PARAGRAPH 1 IS THE SOLE AND EXCLUSIVE WARRANTY GIVEN BY PIERCE. PIERCE HEREBY DISCLAIMS AND EXCLUDES ALL OTHER WARRANTIES, WHETHER EXPRESS, IMPLIED OR STATUTORY, INCLUDING WITHOUT LIMITATION ANY WARRANTY OF MERCHANTABILITY, ANY WARRANTY OF FITNESS FOR A PARTICULAR PURPOSE, AND ANY WARRANTIES ARISING FROM COURSE OF DEALING OR USAGE OF TRADE.

3. BUYER'S EXCLUSIVE REMEDY

If the product fails to conform to the warranty set forth in paragraph 1 during the warranty period, and such nonconformity is not due to misuse, neglect, accident or improper maintenance, Buyer must notify Pierce within the time period specified in paragraph 1, and shall make the product available for inspection by Pierce or its designated agent. At the request of Pierce, any allegedly defective product shall be returned to Pierce by Buyer for examination and/or repair. Buyer shall be responsible for the cost of such transportation, and for risk of loss of or damage to the product during transportation. Within a reasonable time, Pierce shall repair or replace (at Pierce's option and expense) any nonconforming or defective parts. Repair or replacement shall be made only by a facility approved in advance in writing by Pierce. THIS REMEDY SHALL BE THE EXCLUSIVE AND SOLE REMEDY FOR ANY BREACH OF WARRANTY.

4. EXCLUSION OF CONSEQUENTIAL AND INCIDENTAL DAMAGES

Notwithstanding anything to the contrary herein or in any agreement between Pierce and Buyer, IN NO EVENT SHALL PIERCE BE LIABLE FOR ANY CONSEQUENTIAL, INCIDENTAL, SPECIAL, INDIRECT, OR PUNITIVE DAMAGES WHATSOEVER, WHETHER ARISING OUT OF BREACH OF CONTRACT, WARRANTY, TORT (INCLUDING NEGLIGENCE AND STRICT LIABILITY) OR OTHER THEORY OF LAW OR EQUITY, WITH RESPECT TO VEHICLES OR OTHER PRODUCTS SOLD BY PIERCE, OR THEIR OPERATION OR FAILURE TO OPERATE, OR ANY DEFECTS THEREIN, OR ANY UNDERTAKINGS, ACTS OR OMISSIONS RELATED THERETO, REGARDLESS OF WHETHER PIERCE HAS BEEN INFORMED OF THE POSSIBILITY OF ANY SUCH DAMAGES. Without limiting the generality of the foregoing, Pierce specifically disclaims any liability for property or personal injury damages, penalties, damages for lost profits or revenues, loss of vehicles or products or any associated equipment, cost of substitute vehicles or products, down-time, delay damages, any other types of economic loss, or for any claims by any third party for any such damages.

Note: Any Surety Bond, if a part of the sale of the vehicle as to which this limited warranty is provided, applies only to this Pierce Basic One Year Limited Warranty for such vehicle, and not to other warranties made by Pierce in a separate document (if any) or to the warranties (if any) made by any manufacturer (other than Pierce) of any part, component, attachment or accessory that is incorporated into or attached to the vehicle.



AMITY FIRE AND SAFETY, INC.

3750 CHESTNUT ROAD
ALBURTIS, PA 18011-0451
Phone: 610-966-3115
Fax: 610-965-6313

*** STANDARD TEN YEAR WARRANTY ***

(standard warranty is in effect for parts shipped after 4/15/10)

Telescopic Waterways

A. PRESHIPMENT TESTING All waterways fabricated by Amity are final inspected using the following pressure minimums:

1. Hydrostatic applications will be tested to 400 PSI unless specified otherwise on approved drawings. Operating pressures on installed systems are not to exceed 250 PSI at any point in the system. Warranty will be voided and Amity will not be held liable for failure and/or damage occurring from Water Hammering or freezing of water in any system.

B. COMPONENTS DESCRIPTION AND MAINTENANCE

1. All components are thoroughly greased at assembly. Since internally lubricated seals are used, regular greasing is not required. We recommend components not be greased at installation.
2. Slip Tube Assemblies may be greased at the Amity's regularly scheduled Aerial Inspections. The seals in the Slip Tube Assemblies are self-lubricating, so greasing is not mandatory. We do recommend a visual inspection of the Slip Tube Assembly while it is fully extended after initial installation, from that point on we recommend inspection every ten hours of aerial operation. If any deposits of aluminum appear, they are to be rubbed off using a Teflon scouring pad. Slip Tube Assemblies are designed to give long maintenance free service; however, like any product, problems may occur and periodic visual inspections will aid in determining if a potential problem exists and warrants a call to us. Care must be taken to keep debris off of extended tubes. We recommend wiping tubes with light oil (10 weight) or hydraulic oil after use, if tubes appear to have contamination on them. Under no circumstance are tubes to be cleaned with lacquer thinner, or any other solvent.

C. LIMITED WARRANTY, LIMITATIONS, CONDITIONS AND PROCEDURES REQUIRED.

1. Products are warranted to be free of defects in labor and/or materials for a period of ten years from the date of purchase from the Amity and shall be repaired or replaced at the sole option and expense of the Amity provided the products alleged to be defective was used for its intended normal use operation and subject to the following qualifications and limitations.
2. Any alteration of product without consent from Amity is strictly forbidden and shall void warranty.
3. No welding shall be performed on finished product.
4. No responsibility is assumed for any malfunctions or damages which are occasionally caused by foreign objects which may be ingested into water system such as, but not limited to stones, sand or metal chips.
5. Amity assumes responsibility for our product, which is defective only, and therefore, it will not assume responsibility for labor to either remove or install our product unless it agrees in writing to assume such responsibility.
6. Unless otherwise approved in writing by the Amity all returns of defective (or allegedly defective products) are at Purchaser's expense and must include a RGA number issued by the Amity.
7. All warranty claims must be presented at the time the problem occurs, or as soon as practical thereafter, either called or faxed to the Amity and include the numbers on the assembly's Amity's label with a detailed explanation of the difficulty in order for the matter to be appropriately evaluated and resolved.
8. Amity will not be held liable for damage incurred during shipment.
9. No responsibility shall be assumed for misuse or improper mounting, unreasonably use or abuse of the Product and or failure to provide or use improper maintenance, failure to follow written installation and use in instruction or any use other than the customary designed use.

THE REMEDIES PROVIDED IN THE ABOVE EXPRESS LIMITED WARRANTY AND ARE THE SOLE AND EXCLUSIVE REMEDIES AVAILABLE. NO OTHER EXPRESS WARRANTIES ARE MADE. ALL IMPLIED WARRANTIES, INCLUDING BUT NOT LIMITED TO ANY IMPLIED WARRANTY OF MERCHANTABILITY OR

FITNESS FOR A PARTICULAR PURPOSE OR USE ARE LIMITED IN DURATION AS SET FORTH ABOVE. IN NO EVENT SHALL THE AMITY ASSUME OR BE LIABLE FOR ANY INCIDENTAL OR CONSEQUENTIAL DAMAGES.

THE WITHIN DESCRIBED WARRANTY SHALL ONLY BE AFFORDED TO THE ORIGINAL PURCHASER OR FOR INCORPORATION INTO ANOTHER UNIT AND TO FIRST PURCHASER AS PART OF COMPLETED UNIT, HOWEVER, THE WARRANTY PERIOD OF TEN YEARS COMMENCES UPON INSTALLATION INTO FINAL ASSEMBLY WITH THE UNDERSTANDING IT IS INSTALLED WITHIN SIX MONTHS OF PURCHASE.

Dated: _____, 20__

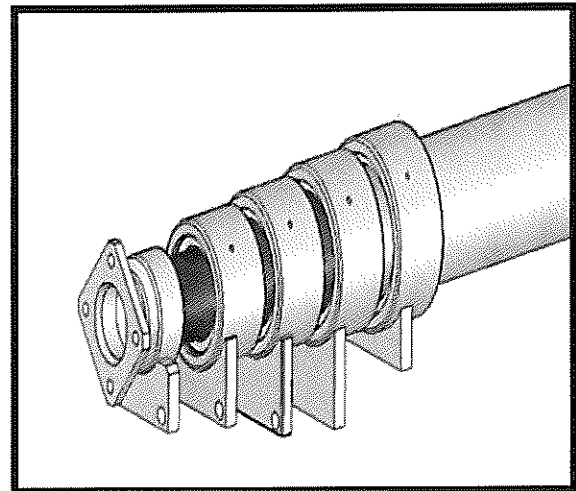
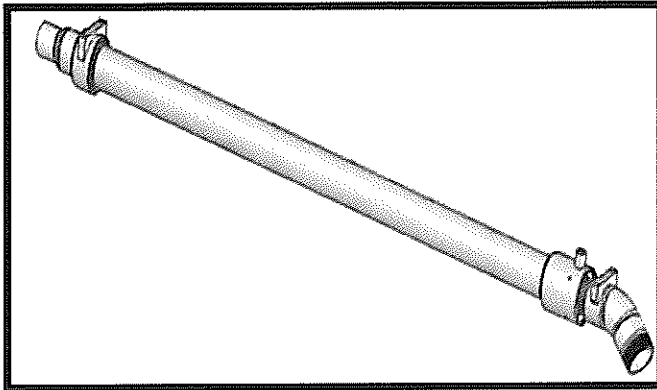



AMITY FIRE AND SAFETY, INC.

3750 CHESTNUT ROAD
ALBURTIS, PA 18011-0451
Phone: 610-966-3115
Fax: 610-965-6313

*** STANDARD FIVE YEAR WARRANTY ***

(standard warranty is in effect for parts shipped after 4/15/10)

Three Function Swivel

A. PRESHIPMENT TESTING The Three Function Swivel fabricated by Amity which is exposed to pressure during normal use is subject to final inspection using the following pressure minimums:

1. Hydrostatic applications will be tested to 400 PSI unless specified otherwise on approved drawings. Operating pressures on installed systems are not to exceed 250 PSI at any point in the system. Warranty will be voided and Amity will not be held liable for failure and/or damage occurring from Water Hammering or freezing of water in any system.
2. Hydraulic applications will be tested to 4000 PSI. System operating pressure in application to be 3000 PSI maximum.
3. Dielectric and Continuity Test all circuits. 30 Amp max current loading.

B. THREE FUNCTION SWIVEL MAINTENANCE – Our Three Function Swivel has been fully tested at assembly. Under no circumstances is there to be any maintenance performed internally or externally to the Three Function Swivel by Purchaser or any other third party other than an authorized representative of or Amity itself. The Three Function Swivel is sealed and must remain so. The Three Function Swivel is designed for a long maintenance free life. Should any problems occur or replacement be necessary, first contact Amity. There is to be no field maintenance performed on the Three Function Swivel .

C. MOUNTING REQUIREMENTS – The following are the mounting requirements for the Three Function Swivel:

1. Mounting points and methods are to be determined at the initial design stage. All drawings and applicable documentation must be signed off by both parties and filed for future reference. No deviation to the approved mounting is allowed without approval from Amity.
2. The Three Function Swivel is to be mounted concentric to the center of the turntable bearing.
3. All inlet and outlet plumbing to conform to swivel mounting, under no circumstances is the Three Function Swivel to be positioned to match connections. This will avoid putting excessive loads on the Three Function Swivel. All tubing or piping to be supported by means other than the Three Function Swivel.

D. LIMITED WARRANTY, LIMITATIONS, CONDITIONS AND PROCEDURES REQUIRED.

1. The Three Function Swivel is warranted to be free of defects in labor and/or materials for a period of five (5) years from the Date of Service. For purposes here, "Date of Service" shall mean the date when the Three Function Swivel, or the unit to which the Three Function Swivel is incorporated, passes final Underwriters Laboratory testing, or similarly compliant testing, and is certified for service. Evidence of such Date of Service shall be required in connection with any warranty claim by Purchaser.
2. The Three Function Swivel shall be repaired or replaced at the sole option and expense of the Amity provided the Three Function Swivel alleged to be defective was used for its intended normal use of operation and subject to the following qualifications and limitations.
3. Any alteration of the Three Function Swivel without consent from Amity is strictly forbidden and shall void warranty.
4. No welding shall be performed on finished Three Function Swivel.
5. No responsibility is assumed for any malfunctions or damages which are occasionally caused by foreign objects which may be ingested into water or hydraulic systems such as, but not limited to stones, sand or metal chips.
6. Amity assumes responsibility for our Three Function Swivel, which is defective only, and therefore, it will not assume responsibility for labor to either remove or install our Three Function Swivel unless it agrees in writing to assume such responsibility.
7. Unless otherwise approved in writing by the Amity all returns of defective Three Function Swivels (or allegedly defective Three Function Swivels) are at Purchaser's expense and must include a RGA number issued by the Amity.

8. All warranty claims must be presented at the time the problem occurs, or as soon as practical thereafter, either called or faxed to the Amity and include the numbers on the assembly's Amity's label with a detailed explanation of the difficulty in order for the matter to be appropriately evaluated and resolved.
9. Amity will not be held liable for damage incurred during shipment.
10. No responsibility shall be assumed for misuse or improper mounting, unreasonable use or abuse of the Three Function Swivel and or failure to provide or use improper maintenance, failure to follow written installation and use in instruction or any use other than the customary designed use.

THE REMEDIES PROVIDED IN THE ABOVE EXPRESS LIMITED WARRANTY AND ARE THE SOLE AND EXCLUSIVE REMEDIES AVAILABLE. NO OTHER EXPRESS WARRANTIES ARE MADE. ALL IMPLIED WARRANTIES, INCLUDING BUT NOT LIMITED TO ANY IMPLIED WARRANTY OF MERCHANTABILITY OR FITNESS FOR A PARTICULAR PURPOSE OR USE ARE LIMITED IN DURATION AS SET FORTH ABOVE. IN NO EVENT SHALL THE AMITY ASSUME OR BE LIABLE FOR ANY INCIDENTAL OR CONSEQUENTIAL DAMAGES.

THE WITHIN DESCRIBED WARRANTY SHALL ONLY BE AFFORDED TO THE ORIGINAL PURCHASER OR FOR INCORPORATION INTO ANOTHER UNIT AND TO FIRST PURCHASER AS PART OF COMPLETED UNIT, HOWEVER, THE WARRANTY PERIOD OF FIVE YEARS IS FROM THE DATE OF SERVICE WITH THE UNDERSTANDING IT IS INSTALLED WITHIN A REASONABLE TIME PERIOD.

Dated: _____, 20__

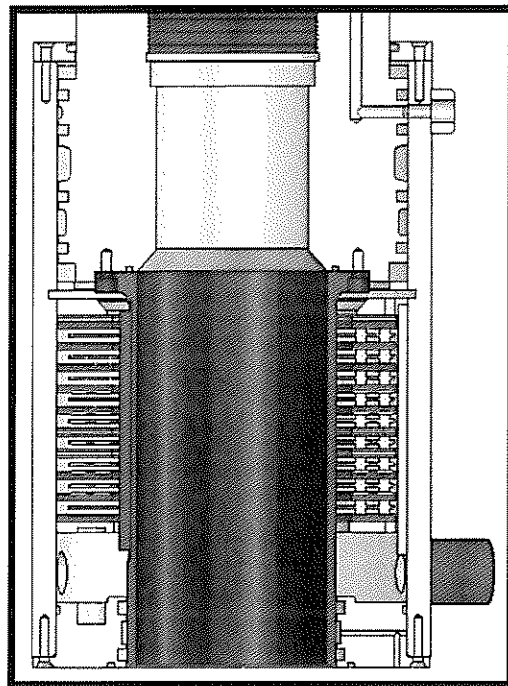
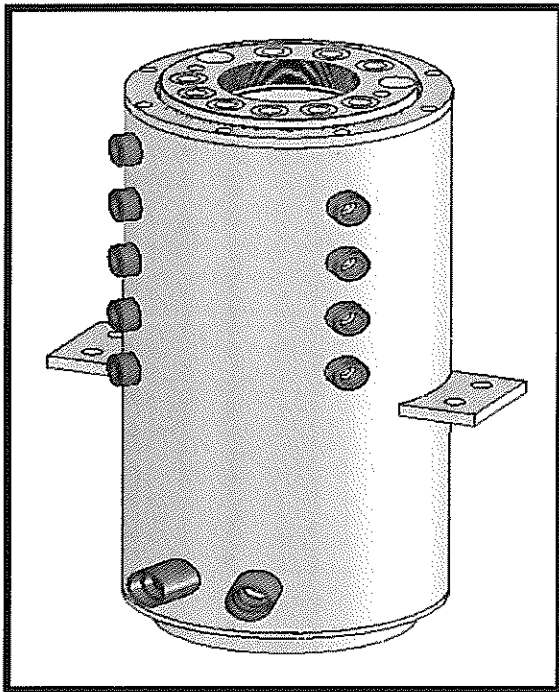



SAFEGUARD TECHNOLOGY, INC.

7207 CHAGRIN ROAD, P.O. BOX 274, CHAGRIN FALLS, OH 44022 U.S.A.
PHONE 440-247-1695 FAX 440-247-1156 CALL TOLL FREE 800-989-1695
www.safeguard-technology.com

June 15, 2004

Mr. Steve Lenz
Manufacturing Engineer
Pierce Manufacturing
2600 American Drive
Appleton, WI 54912-2017

Dear Steve,

Per your request, the following is a guarantee that Safeguard Technology makes on products supplied to Pierce Manufacturing. In addition to the numerous tests conducted by Pierce regarding coefficient of friction, wear cycle, thermal shock and ice dispersion, Safeguard Technology guarantees the following:

Safeguard Technology warrants its pultruded FRP composite fiberglass covers to be free from defects in material and workmanship for a period of 10 years from the date of shipment to Pierce Manufacturing. Safeguard Technology shall be limited at Safeguard Technology's option to repair or replacement of any defective product, or refund of the purchase price thereof. All advice or recommendations supplied by Safeguard Technology is believed but is not warranted to be accurate and complete. Except as set forth herein, Safeguard Technology makes no warranty or merchantability or fitness for neither a particular purpose nor any other warranty, either express or implied, all such warranties being disclaimed. In no event shall Safeguard Technology be liable for special, incidental or consequential losses or damage, either direct or indirect.

The above warranty applies to the products being subjected to foot traffic, for which they were designed. It does not apply when they are subjected to heavy machinery, steel or plastic wheeled dollies, or to solvent cleaning.

A handwritten signature in black ink, appearing to read "Erick R. Schuetz", written over a horizontal line.

Erick R. Schuetz
Manager Sales & Marketing

A handwritten signature in black ink, appearing to read "Jerome G. Kerlek", written over a horizontal line.

Jerome G. Kerlek
Vice President

Manufacturers of Non-Slip Safety Products

Reference Only

NEW PRODUCT WARRANTY



**PARTICIPATING OEM SALES
DISTRIBUTOR SALES**

LIMITED WARRANTY ON NEW ALLISON AUTOMATIC TRANSMISSIONS USED IN EMERGENCY VEHICLE APPLICATIONS

Allison Transmission will provide for repairs or replacement, at its option, during the warranty period of each new Allison transmission listed below that is installed in an Emergency Vehicle in accordance with the following terms, conditions, and limitations.

WHAT IS COVERED

- **WARRANTY APPLIES** — This warranty is for new Allison transmission models listed below installed in an Emergency Vehicle and is provided to the original and any subsequent owner(s) of the vehicle during the warranty period.
- **REPAIRS COVERED** — The warranty covers repairs or replacement, at Allison Transmission’s option, to correct any transmission malfunction resulting from defects in material or workmanship occurring during the warranty period. Needed repairs or replacements will be performed using the method Allison Transmission determines most appropriate under the circumstances.
- **TOWING** — Towing is covered to the nearest Allison Transmission Distributor or authorized Dealer only when necessary to prevent further damage to your transmission.
- **PAYMENT TERMS** — Warranty repairs, including parts and labor, will be covered per the schedule shown in the chart contained in section “APPLICABLE MODELS, WARRANTY LIMITATIONS, AND ADJUSTMENT SCHEDULE.”
- **OBTAINING REPAIRS** — To obtain warranty repairs, take the vehicle to any Allison Transmission Distributor or authorized Dealer within a reasonable amount of time and request the needed repairs. A reasonable amount of time must be allowed for the Distributor or Dealer to perform necessary repairs.
- **TRANSMISSION REMOVAL AND REINSTALLATION** — Labor costs for the removal and re-installation of the transmission, when necessary to make a warranty repair, are covered by this warranty.
- **WARRANTY PERIOD** — The warranty period for all coverages shall begin on the date the transmission is delivered to the first retail purchaser, with the following exception:

Demonstration Service - A transmission in a new truck or bus may be demonstrated to a total of 5000 miles (8000 kilometers). If the vehicle is within this limit when sold to a retail purchaser, the warranty start date is the date of purchase. Normal warranty services are applicable to the demonstrating Dealer. Should the truck or bus be sold to a retail purchaser after these limits are reached, the warranty period will begin on the date the vehicle was first placed in demonstration service and the purchaser will be entitled to the remaining warranty.

APPLICABLE MODELS, WARRANTY LIMITATIONS, AND ADJUSTMENT SCHEDULE

APPLICABLE MODELS	WARRANTY LIMITATIONS (Whichever occurs first)		ADJUSTMENT CHARGE TO BE PAID BY THE CUSTOMER	
	Months	Transmission Miles Or Kilometers	Parts	Labor
MT, MD 3000, 3200, 3500, 3700	0-24	No Limit	No Charge	No Charge
HT with Hydraulic Controls	0-24	No Limit	No Charge	No Charge
AT, 1000 Series™, 2000 Series™, 2400 Series™	0-36	No Limit	No Charge	No Charge
HT with Electronic Controls	0-60	No Limit	No Charge	No Charge
HD 1000 EVS, 2100 EVS, 2200 EVS 2350 EVS, 2500 EVS, 2550 EVS, 3000 EVS, 3500 EVS, 4000, 4000 EVS, 4500, 4500 EVS, 4700, 4700 EVS, 4800, 4800 EVS	0-60	No Limit	No Charge	No Charge

WHAT IS NOT COVERED

- **DAMAGE DUE TO ACCIDENT, MISUSE, or ALTERATION** — Defects and damage caused as the result of any of the following are not covered:
 - Flood, collision, fire, theft, freezing, vandalism, riot, explosion, or objects striking the vehicle;
 - Misuse of the vehicle;
 - Installation into unapproved applications and installations;
 - Alterations or modification of the transmission or the vehicle, and
 - Damage resulting from improper storage (refer to long-term storage procedure outlined in the applicable Allison Service Manual)
 - Anything other than defects in Allison Transmission material or workmanship

NOTE: This warranty is void on transmissions used in vehicles currently or previously titled as salvaged, scrapped, junked, or totaled.

- **CHASSIS, BODY, and COMPONENTS** — The chassis and body company (assemblers) and other component and equipment manufacturers are solely responsible for warranties on the chassis, body, component(s), and equipment they provide. Any transmission repair caused by an alteration(s) made to the Allison transmission or the vehicle which allows the transmission to be installed or operated outside of the limits defined in the appropriate Allison Installation Guideline is solely the responsibility of the entity making the alteration(s).
- **DAMAGE CAUSED by LACK of MAINTENANCE or by the USE of TRANSMISSION FLUIDS NOT RECOMMENDED in the OPERATOR'S MANUAL** — Defects and damage caused by any of the following are not covered:
 - Failure to follow the recommendations of the maintenance schedule intervals applicable to the transmission;
 - Failure to use transmission fluids or maintain transmission fluid levels recommended in the Operator's Manual.
- **MAINTENANCE** — Normal maintenance (such as replacement of filters, screens, and transmission fluid) is not covered and is the owner's responsibility.
- **REPAIRS by UNAUTHORIZED DEALERS** — Defects and damage caused by a service outlet that is not an authorized Allison Transmission Distributor or Dealer are not covered.
- **USE of OTHER THAN GENUINE ALLISON TRANSMISSION PARTS** — Defects and damage caused by the use of parts that are not genuine Allison Transmission parts are not covered.
- **EXTRA EXPENSES** — Economic loss and extra expenses are not covered. Examples include but are not limited to: loss of vehicle use; inconvenience; storage; payment for loss of time or pay; vehicle rental expense; lodging; meals; or other travel costs.
- **"DENIED PARTY" OWNERSHIP** — Warranty repair parts and labor costs are not reimbursed to any participating or non-participating OEMs, dealers or distributors who perform warranty work for, or on behalf of, end users identified by the United States as being a "denied party" or who are citizens of sanctioned or embargoed countries as defined by the U.S. Department of Treasury Office of Foreign Assets Control. Furthermore, warranty reimbursements are not guaranteed if the reimbursement would be contrary to any United States export control laws or regulations as defined by the U.S. Department of Commerce, the U.S. Department of State, or the U.S. Department of Treasury.

OTHER TERMS APPLICABLE TO CONSUMERS AS DEFINED by the MAGNUSON-MOSS WARRANTY ACT

This warranty gives you specific legal rights and you may also have other rights which vary from state to state.

Allison Transmission does not authorize any person to create for it any other obligation or liability in connection with these transmissions.

ANY IMPLIED WARRANTY OF MERCHANTABILITY OR FITNESS FOR A PARTICULAR PURPOSE APPLICABLE TO THESE TRANSMISSIONS IS LIMITED IN DURATION TO THE DURATION OF THIS WRITTEN WARRANTY.

PERFORMANCE OF REPAIRS AND NEEDED ADJUSTMENTS IS THE EXCLUSIVE REMEDY UNDER THIS WRITTEN WARRANTY OR ANY IMPLIED WARRANTY. ALLISON TRANSMISSION SHALL NOT BE LIABLE FOR INCIDENTAL OR CONSEQUENTIAL DAMAGES (SUCH AS, BUT NOT LIMITED TO, LOST WAGES OR VEHICLE RENTAL EXPENSES) RESULTING FROM BREACH OF THIS WRITTEN WARRANTY OR ANY IMPLIED WARRANTY.**

** Some states do not allow limitations on how long an implied warranty will last or the exclusion or limitation of incidental or consequential damages, so the above limitations or exclusions may not apply to you.

OTHER TERMS APPLICABLE TO OTHER END-USERS

THIS WARRANTY IS THE ONLY WARRANTY APPLICABLE TO THE ALLISON TRANSMISSION MODELS LISTED ABOVE AND IS EXPRESSLY IN LIEU OF ANY OTHER WARRANTIES, EXPRESS OR IMPLIED, INCLUDING ANY IMPLIED WARRANTY OF MERCHANTABILITY OR FITNESS FOR A PARTICULAR PURPOSE. ALLISON TRANSMISSION DOES NOT AUTHORIZE ANY PERSON TO CREATE FOR IT ANY OTHER OBLIGATION OR LIABILITY IN CONNECTION WITH SUCH TRANSMISSIONS. ALLISON TRANSMISSION SHALL NOT BE LIABLE FOR INCIDENTAL OR CONSEQUENTIAL DAMAGES RESULTING FROM BREACH OF THIS WARRANTY OR ANY IMPLIED WARRANTY.

QUESTIONS

If you have any questions regarding this warranty or the performance of warranty obligations, you may contact any Allison Transmission Distributor or Dealer or write to:

Allison Transmission, Inc.
P.O. Box 894
Indianapolis, IN 46206-0894
Attention: Warranty Administration PF-9

Form SE0616EN (201009)



AMDOR Inc. TERMS OF BUSINESS AND GENERAL INFORMATION

Warranty:

All AMDOR Inc. roll-up door products are warranted for a period of 10 years from the date of delivery (with the exception of wet paint adhesion - please see below). AMDOR Inc. liability covers the replacement or repair of any component that fails due to defects in material and / or workmanship during the coverage period. We accept no liability for claims made for damages to any part (or parts) of a vehicle and / or machine (of any type) or injury claims by a person or persons assumed or alleged to have been brought about by the use or misuse of any product supplied by AMDOR Inc. Warranty coverage does not extend to door attachments including (but not limited to) decals, emblems, stripes and adhesives.

In order to initiate the claims process please contact your authorized representative of AMDOR Inc. Warranty claims must be accompanied by a written description providing full and reasonable details as to the nature of the defect. Upon receipt of your claim arrangements will be made to inspect the defective product (if necessary). Justified warranty claims will be repaired, exchanged, or credited to the customer's account at AMDOR Inc.'s discretion. All warranty claims must be approved in writing by the Customer Service Manager for AMDOR Inc. There are no exceptions to this clause.

Limited warranty coverage includes the labor associated with the disassembly and assembly of products deemed to be defective by AMDOR Inc. Labor allowances are based on a set time schedule as determined by AMDOR Inc. The maximum allowable hourly labor rate is \$ 50. All warranty labor claims must be approved in writing by an authorized representative of AMDOR Inc. prior to commencement of work. Allowances for removal and installation:

Curtain replacement:	3/4 hour
Balancer replacement:	1 hour
Door ajar switch	3/4 hour
Bottom Panel Assembly:	1/2 hour
Slat replacement:	3/4 hour
Door removal and replacement	1 1/2 hours

Items authorized for return must be accompanied by a Return Goods Authorization (RGA) number. We will accept collect shipments of items deemed to be defective provided that they are returned via the most economical carrier. Should items be

returned by means other than the most economical carrier the difference will be charged back to the sender.

AMDOR Inc. reserves the right to reject any claim when a product has been opened, interfered with or modified. Claims may also be rejected when damage to the product (or any sub-assembly) has been brought about by accident, misuse, abuse, vandalism, incorrect installation, temperature extremes, chemical exposure or any factor other than regular operating conditions.

Limited Wet Paint Match Adhesion Warranty

AMDOR Inc. warrants wet paint finishes applied by AMDOR utilizing our approved factory paint specification. All wet paint match colors must be approved in writing by an authorized OEM representative. AMDOR Inc. will provide a color spray out for this purpose. The time required for shipping and consideration of initial color spray outs will be considered over and above stated lead times. Warranty coverage will extend for a period of not less than 5 years from the date of delivery as determined by AMDOR Inc.'s Packing Slip. AMDOR reserves the right to determine whether individual units will be replaced and / or repaired by an AMDOR approved vendor. An allowance will be made for labor associated with the disassembly and assembly of individual units at the prescribed hourly rate of \$ 50 per hour. Compensation for labor will not exceed the maximum time allowance permitted for door removal and replacement. Written approval including specified allowance for time must be obtained from AMDOR prior to initiating work. Warranty coverage will extend to the following visible paint system defects:

- 1./ Loss of mechanical adhesion as evidenced by peeling, cracking or blistering which exposes the substrate material.
- 2./ Corrosion of the substrate due to paint system failure.
- 3./ Fading which results in a substantial departure from the primary AMDOR approved body color.

Wet paint adhesion limited warranty coverage will be excluded when damages to the system are determined by AMDOR Inc. to be a result of the following:

- 1./ Damage caused through the use of attachments including (but not limited to) decals, labels, adhesives, non factory approved coatings.
- 2./ Loss of gloss, discoloration or damage due to improper maintenance (including but not limited to) mechanical wash systems, pressure washers, steam cleaners, non approved wash or polishing agents.
- 3./ Abuse, acts of nature, excessive heat / cold, chemical exposure, vandalism and / or accidents.
- 4./ Scratches, chips, abrasions, or dents from any source.

This document supercedes all previous written and / or verbal warranties provided by AMDOR Inc. and / or it's affiliates.



Cummins Warranty

Worldwide

Fire Apparatus/Crash Trucks



Coverage

Products Warranted

This Warranty applies to new diesel Engines sold by Cummins and delivered to the first user on or after April 1, 2007, that are used in fire apparatus truck and crash truck* applications Worldwide.

Base Engine Warranty

The Base Engine Warranty covers any failures of the Engine which result, under normal use and service, from a defect in material or factory workmanship (Warrantable Failure). This Coverage begins with the sale of the Engine by Cummins and ends five years or 100,000 miles (160,935 kilometers), whichever occurs first, after the date of delivery of the Engine to the first user.

Engine aftertreatment components included in the Cummins Critical Parts List (CPL) and marked with a Cummins part number are covered under Base Engine Warranty.

Additional Coverage is outlined in the Emission Warranty section.

These Warranties are made to all Owners in the chain of distribution and Coverage continues to all subsequent Owners until the end of the periods of Coverage.

Cummins Responsibilities

Cummins will pay for all parts and labor needed to repair the damage to the Engine resulting from a Warrantable Failure.

Cummins will pay for the lubricating oil, antifreeze, filter elements, belts, hoses and other maintenance items that are not reusable due to the Warrantable Failure.

Cummins will pay for reasonable labor costs for Engine removal and reinstallation when necessary to repair a Warrantable Failure.

Cummins will pay reasonable costs for towing a vehicle disabled by a Warrantable Failure to the nearest authorized repair location. In lieu of the towing expense, Cummins will pay reasonable costs for mechanics to travel to and from the location of the vehicle, including meals, mileage and lodging when the repair is performed at the site of the failure.

Owner Responsibilities

Owner is responsible for the operation and maintenance of the Engine as specified in Cummins Operation and Maintenance Manuals. Owner is also responsible for providing proof that all recommended maintenance has been performed.

Before the expiration of the applicable Warranty, Owner must notify a Cummins distributor, authorized dealer or other repair location approved by Cummins of any Warrantable Failure and make the Engine available for repair by such facility. Except for Engines disabled by a Warrantable Failure, Owner must also deliver the Engine to the repair facility.

Service locations are listed on the Cummins Worldwide Service Locator at cummins.com.

Owner is responsible for the cost of lubricating oil, antifreeze, filter elements and other maintenance items provided during Warranty repairs unless such items are not reusable due to the Warrantable Failure.

Owner is responsible for communication expenses, meals, lodging and similar costs incurred as a result of a Warrantable Failure.

Owner is responsible for non-Engine repairs and for "downtime" expenses, cargo damage, fines, all applicable taxes, all business costs and other losses resulting from a Warrantable Failure.

Owner is responsible for a \$100 (U.S. Dollars) deductible per each service visit under this plan in the 3rd, 4th and 5th years of Base Engine Warranty. The deductible will not be charged during the first 2 years of the Base Engine Warranty.

Limitations

Cummins is not responsible for failures or damage resulting from what Cummins determines to be abuse or neglect, including, but not limited to: operation without adequate coolants or lubricants; overfueling; overspeeding; lack of maintenance of lubricating, cooling or intake systems; improper storage, starting, warm-up, run-in or shutdown practices; unauthorized modifications of the Engine.

Any unauthorized modifications to the aftertreatment could negatively effect emissions certification and void Warranty.

Cummins is also not responsible for failures caused by incorrect oil, fuel or diesel exhaust fluid or by water, dirt or other contaminants in the fuel, oil or diesel



exhaust fluid.

This Warranty does not apply to accessories supplied by Cummins which bear the name of another company. Such non-warranted accessories include, but are not limited to: alternators, starters, fans, air conditioning compressors, clutches, filters, transmissions, torque converters, vacuum pumps, power steering pumps, fan drives and air compressors. Cummins branded alternators and starters are covered for the first two years from the date of delivery of the Engine to the first user, or the expiration of the Base Engine Warranty, whichever occurs first.

Failures resulting in excessive oil consumption are not covered beyond the duration of the Coverage or 100,000 miles (160,935 kilometers) or 7,000 hours from the date of delivery of the Engine to the first user, whichever of the three occurs first. Before a claim for excessive oil consumption will be considered, Owner must submit adequate documentation to show that consumption exceeds Cummins published standards.

Failures of belts and hoses supplied by Cummins are not covered beyond the first year from the date of delivery of the Engine to the first user or the duration of the Warranty, whichever occurs first.

Parts used to repair a Warrantable Failure may be new Cummins parts, Cummins approved rebuilt parts or repaired parts. Cummins is not responsible for failures resulting from the use of parts not approved by Cummins.

A new Cummins or Cummins approved rebuilt part used to repair a Warrantable Failure assumes the identity of the part it replaced and is entitled to the remaining Coverage hereunder.

Cummins Inc. reserves the right to interrogate Electronic Control Module (ECM) data for purposes of failure analysis.

CUMMINS DOES NOT COVER WEAR OR WEAROUT OF COVERED PARTS.

CUMMINS IS NOT RESPONSIBLE FOR INCIDENTAL OR CONSEQUENTIAL DAMAGES.

THIS WARRANTY AND THE EMISSION WARRANTY SET FORTH HEREINAFTER ARE THE SOLE WARRANTIES MADE BY CUMMINS IN REGARD TO THESE ENGINES. CUMMINS MAKES NO OTHER WARRANTIES, EXPRESS OR IMPLIED, OR OF MERCHANTABILITY OR FITNESS FOR A PARTICULAR PURPOSE.

This Warranty gives you specific legal rights, and you may also have other rights which vary from state to state.

Emission Warranty

Products Warranted

This Emission Warranty applies to new Engines marketed by Cummins that are used in the United States** in vehicles designed for transporting persons or property on a street or highway. This Warranty applies to Engines delivered to the first user on or after September 1, 1992.

Coverage

Cummins warrants to the first user and each subsequent purchaser that the Engine is designed, built and equipped so as to conform at the time of sale by Cummins with all U.S. federal emission regulations applicable at the time of manufacture and that it is free from defects in material or factory workmanship which would cause it not to meet these regulations within the longer of the following periods: (A) Five years or 100,000 miles (160,935 kilometers) of operation, whichever occurs first, as measured from the date of delivery of the Engine to the first user or (B) The Base Engine Warranty.

If the vehicle in which the Engine is installed is registered in the state of California, a separate California Emission Warranty also applies.

Limitations

Failures, other than those resulting from defects in material or factory workmanship, are not covered by this Warranty.

Cummins is not responsible for failures or damage resulting from what Cummins determines to be abuse or neglect, including, but not limited to: operation without adequate coolants or lubricants; overfueling; overspeeding; lack of maintenance of lubricating, cooling or intake systems; improper storage, starting, warm-up, run-in or shutdown practices; unauthorized modifications of the Engine.

Any unauthorized modifications to the aftertreatment could negatively effect emissions certification and void Warranty.

Cummins is also not responsible for failures caused by incorrect oil, fuel or diesel exhaust fluid or by water, dirt or other contaminants in the fuel, oil or diesel exhaust fluid.

Cummins is not responsible for non-Engine repairs, "downtime" expenses, cargo damage, fines, all applicable taxes, all business costs or other losses resulting from a Warrantable Failure.

**CUMMINS IS NOT RESPONSIBLE FOR INCIDENTAL
OR CONSEQUENTIAL DAMAGES.**

* Airport operated crash trucks and fire department
operated trucks employed to respond to fires,
hazardous material releases, rescue and other
emergency-type situations.

** United States includes American Samoa, the
Commonwealth of Northern Mariana Islands, Guam,
Puerto Rico and the U.S. Virgin Islands.



Cummins Inc.
Box 3005
Columbus, IN 47202-3005
U.S.A.

Bulletin 3381161
Printed in U.S.A. Rev. 08/09
©2001 Cummins Inc.



MANUFACTURER'S LIMITED WARRANTY

Harrison extends to the original purchaser of goods for use, the following warranty covering the Harrison Hydra-Gen® Generator System manufactured or supplied by Harrison Hydra-Gen®, subject to the qualifications indicated. A Harrison Hydra-Gen® Generator System consists of one or more of the following Assemblies: a Hydraulic Motor/Alternator Assembly, a Hydraulic Heat Exchanger/Fan Assembly, a Hydraulic Pump Assembly, a Hydraulic Reservoir Assembly, a Hydraulic Control Valve/Manifold Assembly or a Meter Head Assembly.

THERE IS NO OTHER EXPRESS WARRANTY. IMPLIED WARRANTIES, INCLUDING MERCHANTABILITY AND FITNESS FOR A PARTICULAR PURPOSE, ARE LIMITED TO PERIODS OF WARRANTY SET FORTH BELOW AND TO THE EXTENT PERMITTED BY LAW. ANY AND ALL IMPLIED WARRANTIES ARE EXCLUDED. IN NO EVENT IS HARRISON LIABLE FOR INCIDENTAL OR CONSEQUENTIAL DAMAGES.

1. Harrison Hydra-Gen® warrants the original purchaser for the period set forth below, that the Generator System manufactured or supplied by Harrison Hydra-Gen® will be free from defects in workmanship and material, provided such goods are installed, operated and maintained in accordance with Harrison's written installation instructions, and further provided that each new application be reviewed and approved by Harrison's Application Engineering Group.

<u>PRODUCT APPLICATION</u>	<u>PERIOD OF WARRANTY</u>
Harrison Hydra-Gen® Generator Systems used in commercial vehicles or marine applications.	Two (2) years or 2,000 hours, which ever comes first, from the date product is received.
Repair or replacement parts.	Ninety (90) days from date of purchase Excludes Labor

2. Form WR-1 must be completed and returned to Harrison within 30 days of the product being delivered to the end user. Form WR-1 must be signed by an authorized Harrison agent and a copy returned to the end user.
3. Harrison's sole liability and Purchaser's sole remedy for a failure of goods under this warranty and for any and all other claims arising out of the purchase and use of the goods, including negligence on the part of the manufacturer, shall be limited to the repair or replacement of the product, at Harrison's option, of the parts that do not conform to this warranty, provided that the product or parts are returned to Harrison's factory at 10827 Tower Oaks Blvd, Houston, Texas 77070, or at a Harrison Authorized Distributor or it's designated service representative, transportation prepaid.
4. All claims must be brought to the attention of Harrison, an Authorized Distributor or designated service representative within thirty (30) days after goods or parts failed to meet this warranty.
5. THIS WARRANTY SHALL NOT APPLY TO:
 - a. Cost of maintenance, adjustments, installation or startup.
 - b. Paint, hydraulic fluid, and interconnecting hoses (internal or external to system assemblies).
 - c. Failures due to accident, misuse, abuse, negligence, improper installation or lack of maintenance.
 - d. Products altered or modified in a manner not authorized by the manufacturer in writing.
 - e. Telephone or other communications expense.
 - f. Excessive labor due to components being concealed in vehicle as a result of installation.
 - g. High water, road debris, or excessive dirt.
6. No person is authorized to give any other warranties or to assume any other liabilities on Harrison's behalf, unless made or assumed in writing by an officer of Harrison.
7. This warranty gives the user specific legal rights, and the user may also have other rights that may vary from state to state.

**MERITOR® COMMERCIAL
VEHICLE SYSTEMS**

WARRANTY/MODEL YEAR 2014 VEHICLES



MERITOR



SIMPLER IS BETTER

Warranty coverage is essential to protecting your investment. But understanding the full details of your coverage can be challenging. This straightforward approach allows you, our valued customer, to better understand how your specific vehicle applications will be covered.

Advantage Program

Purchasing additional coverage on select components will continue to safeguard your investment against major repair costs after the initial base coverage expires. You can find out more about the Advantage Program by visiting www.meritor.com or by contacting Meritor at 866-OnTrac1 (866-668-7221).



WARRANTY INFORMATION CONTENTS

Effective Model Year 2014 Vehicles

Linehaul	4-5
General Service	6-7
Heavy Service.....	8-9
Off-Highway Service.....	10
Terms and Conditions.....	11

How to Read Warranty Coverage

Number of Years	Mileage (in thousands) Uni=Unlimited	P=Parts Only P&L=Parts & Labor
-----------------	---	-----------------------------------

Notice:

Models or components that are approved for use by Meritor's vocational guidelines contained in Meritor Publication TP-9441 for axles, SP-8320 for trailer axles, TP-12126 for drivelines, which are not specifically listed, are warranted for one year, unlimited miles, parts only (1/Unl/P).

Products purchased on an incomplete vehicle (glider) are limited to one year, unlimited miles parts only (1/Unl/P).

LINEHAUL WARRANTY INFORMATION

Linehaul Vehicles

- | | | | |
|--|---|--|--|
| <input checked="" type="checkbox"/> Auto Hauler | <input checked="" type="checkbox"/> Flatbed | <input checked="" type="checkbox"/> Livestock Hauler | <input checked="" type="checkbox"/> Refrigerated Freight |
| <input checked="" type="checkbox"/> Bulk Hauler | <input checked="" type="checkbox"/> General Freight | <input checked="" type="checkbox"/> Moving Van | <input checked="" type="checkbox"/> Tanker |
| <input checked="" type="checkbox"/> Chip Hauler (Truck)* | <input checked="" type="checkbox"/> Grain Hauler | <input checked="" type="checkbox"/> Pipe Hauler | <input checked="" type="checkbox"/> Triples |
| <input checked="" type="checkbox"/> Doubles | | | |

* Chip Hauler vehicles require specific axle models listed below and Linehaul condition to be eligible for Linehaul warranty consideration.

Linehaul Typically Is

- High mileage operation (over 60,000 miles/year)
- Well maintained major highways of concrete or asphalt construction
- Greater than 30 miles between starting and stopping

Coverage under Meritor's warranty requires that the application of products be properly approved pursuant to OEM and Meritor approvals. Refer to TP-9441 for axles, SP-8320 for trailer axles, TP-12126 for drivelines, and/or contact Meritor regarding specific application approval questions on any product line.

Front Non-Drive Steer Axles – 5/750/P&L

FD-965	FF-944	FG-941	MFS-10-144A-N	MFS-13-143A-N
FF-941	FF-961	FG-943	MFS-12-143A-N	MFS-13-144A-N
FF-942	FF-966	MFS-10-122A	MFS-12-144A-N	MFS-14-143A-N
FF-943	FF-967	MFS-10-143A-N	MFS-125-143A-N	

Rear Drive Single Axles – 5/750/P&L

RS-19-144/145/A	RS-21-160	RS-23-161
MS-19-14X	RH-23-160	RS-23-186
MS-21-144MA-N	RS-23-160	
RS-21-145	RH-23-161	

Rear Drive Tandem/Tridem Axles – 5/750/P&L

RT-34-144/P/A	MA-40-165	MT-40-943
RT-40-145/P/A	MT-34-14X/P	RZ-166 ²
RT-40-160/P ^{1,2}	MT-40-14X/P	RZ-188
RT-46-160/P ^{1,2}	MT-40-14X/P	
RT-46-164EH/P ^{1,2}	MT-40-143	
RT-50-160/P ^{1,2}	MT-40-144/P	

Drivelines

RPL	4/400/P, 1/Unl/P&L
MXL	3/350/P, 1/Unl/P&L
155N	1/Unl/P
92N	1/Unl/P

¹ These models required for Chip Hauler and Linehaul warranty consideration.
² Each vehicle must have a Request for Application Recommendation (RAR) approved by Meritor prior to vehicle build. All RARs must identify the chassis number or VIN. Refer to Product Information Letter #303 and #396 for further details.



LINEHAUL WARRANTY INFORMATION

Brake Components

Cam Q Series Trailer Brakes	5/500/P, 1/100/L
LX500 Feature ¹	5/750/P&L
Cam Q Plus™	5/500/P, 1/Unl/P&L
ASA	5/500/P, 1/Unl/P&L
Hubs/Cast Drums and Other Wheel-end Components	1/Unl/P
Hydraulic Disc Brakes	1/Unl/P
All Other Brakes	1/Unl/P
X30™ Drums ²	12-Years or Wearable Life/P
EX Air Disc Brake	5/500/P, 1/Unl/L

¹ Includes: bushing, seal, cam, ASA lubrication and wear coverage of 3/500/P&L.

² Based on stamped wear diameter max.

Trailer Axles

Beam and Brackets	5/500/P, 1/100/L
Wheel End Systems ¹	
Standard System ²	1/100/P&L
PreSet by Meritor ³	5/500/P&L
AxlePak ⁴	4P/3L
Beam and Brackets	5/500/P, 1/100/L
AxlePak ⁵	6P/5L
Beam and Brackets	6/600/P, 1/100/L

¹ Includes hub, wheel seals and wheel bearings—all systems require annual inspections and proper documentation to ensure full coverage.

² When installed by Meritor.

³ Requires approved hubcap stating PreSet by Meritor on hubcap face.

⁴ Applies to STEMCO Guardian HP Seal, STEMCO Pro-Torq nut, STEMCO Integrated Sentinel Hub Cap, and Meritor bearings.

⁵ Applies to STEMCO Guardian HP Seal, STEMCO Pro-Torq nut, STEMCO Integrated Sentinel Hub Cap, and STEMCO matched bearing sets.

(For brake components and ABS coverage, refer to appropriate product warranties.)

TAG/Pusher Axles¹

TQ, TQD, TR, TRD Beam and Brackets	5/750/P&L
------------------------------------	-----------

¹ For brake components and ABS Coverage, refer to appropriate product warranties.

Meritor Tire Inflation System by PSI

MTIS Components	3/500/P&L
-----------------	-----------

Trailer Air Suspension Systems

MPA38/40 (Tandem Axle Parallelogram) ¹	
Major Structural Components	5/500/P, 1/100/L
Height Control Valve	1/100/P&L
Shock Absorbers	2/200/P&L
Air Springs	2/200/P, 1/100/L
Bushings	7/Unl/P, 5/Unl/L
PinLoc Air Controls	1/100/P&L
PinLoc Actuator	3/300/P&L
MPA20 (Single Axle Parallelogram)	
Major Structural Components	5/500/P, 1/100/L
Height Control Valve	1/100/P&L
Shock Absorbers	2/200/P&L
Air Springs	2/200/P, 1/100/L
Bushings	7/Unl/P, 5/Unl/L
MTA (Trailing Arm)	
Major Structural Components	5/500/P, 1/100/L
Height Control Valve	1/100/P&L
Shock Absorbers	2/200/P&L
Air Springs & Rebound Straps	2/200/P, 1/100/L
Bushings	5/500/P, 3/300/L

¹ Fastener torque coverage is limited to 2/Unl P&L when torqued by Meritor (For axle and ABS coverage, refer to appropriate product warranties.)

GENERAL SERVICE WARRANTY INFORMATION

General Service Vehicles

- | | | | |
|-----------------------|-----------------------------------|------------------------------|------------------------|
| ■ Aerial Ladder Truck | ■ Front Engine Commercial Chassis | ■ Municipal Truck | ■ Refrigerated Freight |
| ■ Aerial Platform | ■ Front Engine Integral Coach | ■ Newspaper Delivery | ■ School Bus |
| ■ Ambulance | ■ General Freight | ■ Pick-Up and Delivery | ■ Stake Truck |
| ■ Auto Hauler | ■ Intercity Coach | ■ Pipe Hauler | ■ Tanker |
| ■ Beverage Truck | ■ Intermodal Chassis | ■ Platform Auto Hauler | ■ Tanker Truck |
| ■ Chip Hauler | ■ Livestock Hauler | ■ Pumper | ■ Tour Bus |
| ■ Cross Country Coach | ■ Meat Packer | ■ Rear Engine Integral Coach | ■ Wrecker |
| ■ Flatbed | ■ Moving Van | ■ Recreational Vehicles | |

General Service Typically Is

- Lower mileage operations (less than 60,000 miles/year)
- Generally, on-road service (less than 10% off-road)
- An average of three (3) miles between starting and stopping

Coverage under Meritor's warranty requires that the application of products be properly approved pursuant to OEM and Meritor approvals. Refer to TP-9441 for axles, SP-8320 for trailer axles, TP-12126 for drivelines, and/or contact Meritor regarding specific application approval questions on any product line.

Front Drive/Non-Drive Steer Axles – 2/Unl/P&L

FD-965	FF-967	MFS-6-162B-N	MFS-8-153B-N	MFS-13-122A-N
FF-941	FG-941	MFS-6-153C-N	MFS-8-163B-N	MFS-13-143A-N
FF-942	FH-941	MFS-6-162C-N	MFS-10-122A	MFS-13-144A-N
FF-943	FH-946 ¹	MFS-7-113C-N	MFS-10-143A-N	MFS-14-143A-N
FF-944	FL-941	MFS-7-153C-N	MFS-10-144A-N	MFS-16-122A-N
FF-946	FL-943	MFS-7-163C-N	MFS-12-143A-N	MFS-16-143A-N
FF-961	MFS-6-151A-N	MFS-8-113B-N	MFS-12-144A-N	MFS-18-133A-N
FF-966	MFS-6-153B-N	MFS-8-143A-N	MFS-125-143A-N	MFS-20-133A-N

¹ Can also be used with reduced steer angles in tag position in Coach Applications.

Rear Drive Single Axles – 2/Unl/P&L

MS-10-113	RS-19-144/145/A	RC-23-160	RS-23-161	RS-30-185
MS-11-113	MS-21-14X	RC-23-161	RS-23-161	MS-30-616
MS-12-113	MS-21-144MA-N	RC-23-162 ¹	RS-23-186	RS-35-380
MS-17-14X	RS-21-145	RC-23-165 ¹	RS-24-160	71162
MS-19-14X	RS-21-145/A	RH-23-160	RC-25-160	71163
RS-13-120	RS-21-160	RH-23-161	RS-25-160	79163
RS-15-120	RC-22-145	RS-23-160	RS-26-185	
RS-17-144/145/A	RC-22-145/A	RS-23-160	MS-26-616	

¹ 3/Unl/P&L if PreSet by Meritor.

Rear Drive Tandem – 3/Unl/P&L

RT-40-160/P	RT-46-164EH/P
RT-46-160/P	RT-50-160/P

Drivelines

RPL	4/400/P, 1/Unl/P&L
MXL	3/350/P, 1/Unl/P&L
155N	1/Unl/P
92N	1/Unl/P

Rear Drive Tandem/Tridem Axles – 2/Unl/P&L

MT-34-14X/P	MT-40-144/P	MT-52-616	RZ-166
RT-34-144/P/A	RT-40-145/P/A	RT-52-185 ²	RZ-188
MT-40-14X/P	MT-44-14X/P	MT-58-616	
MT-40-143DA-N	RT-44-145/P	RT-58-185 ²	
MT-40-143MA-N ¹	RT-46-169	MT-70-380	

¹ Axle model designated will vary according to options and variations specified on these axles. Contact Meritor Axle Applications Engineering for details.

² Each vehicle must have a Request for Application Recommendation (RAR) approved by Meritor prior to vehicle build. All RARs must identify the chassis number or VIN. Refer to Product Information Letter #303 and #396 for further details.



GENERAL SERVICE WARRANTY INFORMATION

Brake Components

Cam Q Series Trailer Brakes	3/Unl/P, 1/Unl/L
LX500 Feature ¹	3/Unl/P&L
Cam P ²	2/200/P
Cam	3/Unl/P
Cam Q Plus™	3/Unl/P&L
Cam Q Plus™ ³	2/200/P&L
ASA	3/Unl/P
ASA ³	2/200/P
Hubs/Cast Drums and Other Wheel-end Components	1/Unl/P
Hydraulic Disc Brakes	1/Unl/P
All Other Brakes	1/Unl/P
X30™ Drums ²	12-Years or Wearable Life/P
EX Air Disc Brake	2/Unl/P&L

¹ Includes: bushing, seal, cam, ASA lubrication and wear coverage of 1/Unl/P.

² Based on stamped wear diameter max.

³ Applies to Tour Bus and Cross Country Coach only.

Trailer Axles

Beam and Brackets ¹	5/500/P, 1/100/L
Wheel End Systems ²	
Standard System ³	1/Unl/P&L
AxlePak4 ⁴	4P/3L
Beam and Brackets	5/500/P, 1/100/L
AxlePak6 ⁵	6P/5L
Beam and Brackets	6/600/P, 1/100/L

¹ 9000 Series is 3/Unl/P, 1/Unl/L

² Includes hub, wheel seals and wheel bearings—all systems require annual inspections and proper documentation to ensure full coverage.

³ When installed by Meritor

⁴ Applies to STEMCO Guardian HP Seal, STEMCO Pro-Torq nut, STEMCO Integrated Sentinel Hub Cap, and Meritor bearings.

⁵ Applies to STEMCO Guardian HP Seal, STEMCO Pro-Torq nut, STEMCO Integrated Sentinel Hub Cap, and STEMCO matched bearing sets.

(For brake components and ABS coverage, refer to appropriate product warranties.)

Chassis Axles (2000 Series/ChassiPak)

Beam & Brackets	6/Unl/P, 1/Unl/L
Wheel End Systems ¹	
Standard System	1/Unl/P&L
AxlePak4 ²	4P/3L
Beam and Brackets	7P/1L
AxlePak6 ³	6P/5L
Beam and Brackets	7P/1L

¹ Includes hub, wheel seals and wheel bearings—all systems require annual inspections and proper documentation to ensure full coverage.

² Applies to STEMCO Guardian HP Seal, STEMCO Pro-Torq nut, STEMCO Integrated Sentinel Hub Cap, and Meritor bearings.

³ Applies to STEMCO Guardian HP Seal, STEMCO Pro-Torq nut, STEMCO Integrated Sentinel Hub Cap, and STEMCO matched bearing sets.

Trailer Air Suspension Systems

MPA38/40 (Tandem Axle Parallelogram) ¹	
Major Structural Components	5/Unl/P, 1/Unl/L
Height Control Valve	1/Unl/P&L
Shock Absorbers	2/Unl/P&L
Air Springs	2/Unl/P, 1/Unl/L
Bushings	7/Unl/P, 5/Unl/L
Air Controls	1/100/P&L
Air Actuator	3/300/P&L
MPA20 (Single Axle Parallelogram)	
Major Structural Components	5/Unl/P, 1/Unl/L
Height Control Valve	1/Unl/P&L
Shock Absorbers	2/Unl/P&L
Air Springs	2/Unl/P, 1/Unl/L
Bushings	7/Unl/P, 5/Unl/L
MTA (Trailing Arm)	
Major Structural Components	5/Unl/P, 1/Unl/L
Height Control Valve	1/Unl/P&L
Shock Absorbers	2/Unl/P&L
Air Springs and Rebound Straps	2/Unl/P, 1/Unl/L
Bushings ²	5/Unl/P, 3/Unl/L

(For axle and ABS coverage, refer to appropriate product warranties.)

¹ Fastener torque coverage is limited to 2/Unl P&L when torqued by Meritor

² Raw wood applications 3/Unl/P, 1/Unl/L

TAG/Pusher Axles

TQ, TQD, TR, TRD Beam and Brackets ¹	3/Unl/P, 1/Unl/L
MC12002, MC14002, MC16003, FH946	2/Unl/P&L

(For brake components and ABS coverage, refer to appropriate product warranties.)

¹ 3/Unl/P&L if sold with PreSet by Meritor.

Meritor® Tire Inflation System by PSI

MTIS Components	3/500/P&L
-----------------	-----------

HEAVY SERVICE WARRANTY INFORMATION

Heavy Service Vehicles

- Airport Rescue Fire (ARF)
- Airport Shuttle
- Asphalt Truck
- Block Truck
- Bottom Dump Trailer Combination
- Cementing Vehicle
- City Bus
- Commercial Pick-Up
- Concrete Pumper
- Construction Material Hauler
- Crash Fire Rescue (CFR)
- Mixer
- Demolition
- Drill Rig
- Dump
- Emergency Service
- Equipment Hauling
- Flatbed Trailer Hauler
- Flatbed Truck
- Fracturing Truck
- Front Loader
- Geophysical Exploration
- Hopper Trailer Combinations
- Landscaping Truck
- Liquid Waste Hauler
- Log Hauling
- Lowboy
- Michigan Special Gravel Trains
- Michigan Special Log Hauler
- Michigan Special Steel Hauler
- Michigan Special Waste Vehicle
- Municipal Dump
- Rapid Intervention Vehicle (RIV)
- Rear Loader
- Recycling Truck
- Residential Pick-Up
- Rigging Truck
- Roll-Off
- Scrap Truck
- Semi-End Dump
- Sewer/Septic Vacuum
- Shuttle Bus
- Side Loader
- Snowplow/Snowblower
- Steel Hauling
- Tanker
- Tank Truck
- Tractors with Pole Trailers
- Tractor/Trailer with Jeeps
- Transfer Dump
- Transfer Vehicle
- Transit Bus
- Trolley
- Utility Truck
- Winch Truck

Heavy Service Typically Is

- Moderate mileage operation (less than 60,000 miles per year)
- On/Off road vocations (10% or more off-road)
- Moderate to frequent stops/starts (up to 10 stops per mile)

Coverage under Meritor's warranty requires that the application of products be properly approved pursuant to OEM and Meritor approvals. Refer to TP-9441 for axles, SP-8320 for trailer axles, TP-12126 for drivelines, and/or contact Meritor regarding specific application approval questions on any product line.

Front Drive/Non-Drive Steer Axles – 2/Uni/P&L

FD-965	FG-941	MFS-6-162C	MFS-10-144A-N	MFS-16-143A-N	MX-18-120
FF-941	FG-943	MFS-7-113C-N	MFS-12-143A-N	MFS-18-133A-N	MX-17-140
FF-942	FH-941	MFS-7-153C-N	MFS-12-144A-N	MFS-20-133A-N	MX-19-140
FF-943	FH-946	MFS-7-163C-N	MFS-12-155	RF-16-145	MX-21-140
FF-944	FL-941	MFS-8-113B-N	MFS-13-143A-N	RF-21-160	MX-21-160
FF-946	FL-943	MFS-8-153B-N	MFS-13-144A-N	MX-10-120	MX-23-160
FF-961	MFS-6-151A-N	MFS-8-163B-N	MFS-13-155	MX-12-120	MX-23-810
FF-966	MFS-6-153B	MFS-10-122A	MFS-14-143A-N	MX-14-120	
FF-967	MFS-6-162B	MFS-10-143A-N	MFS-16-122A-N	MX-16-120	

Drivelines – 1/Uni/P&L

RPL 92N RN MXL

Rear Drive Single Axles – 2/Uni/P&L

MS-10-113	RC-23-160	MS-26-616
RS-13-120	RH-23-160	RS-26-185/380
RS-15-120	RS-23-160	MS-30-616
MS-17-14X	RS-23-160	RH-30-185
RS-17-144/145/A	RC-23-161	RS-30-185/380
MS-19-14X	RH-23-161	MS-35-380
RS-19-144	RS-23-161	RS-38-380
MS-21-114	RS-23-186/380	RC-25-160
MS-21-14X	RC-23-162	RC-26-633
RS-21-145	RC-23-165	MT-58-616
RS-21-145/A	RS-24-160	71162
RS-21-160	RS-25-160	71163
RC-22-145	RH-26-185	79163



HEAVY SERVICE WARRANTY INFORMATION

Rear Drive Tandem/Tridem Axles – 2/Unl/P&L

MT-34-14X/P	MT-40-144	RT-46-169	RT-70-380 ⁵
RT-34-144/P/A	MT-40-144/P	MT-52-616	MT-70-380 ⁵
MT-40-14X/P	RT-40-145/P/A	RT-52-185/380 ^{2,3,4,5}	RZ-166 ⁵
MT-40-143DA-N	MT-44-14X/P	MT-58-616	RZ-188 ⁵
MT-40-143MA-N ¹	RT-44-145/P	RT-58-185/380 ^{2,3,4,5}	

¹ U.S. only. Canadian warranty = 1/Unl/P for combination vehicles only.

² Axle model designated will vary according to options and variations specified on these axles. Contact Meritor Axle Applications Engineering for details.

³ Axle model designated will vary according to options and variations specified on these axles. Contact Meritor Axle Applications Engineering for details.

⁴ Each vehicle must have a Request for Application Recommendation (RAR) approved by Meritor prior to vehicle build. All RARs must identify the chassis number or VIN. Refer to Product Information Letter #303 and #396 for further details.

⁵ Warranty is 1/Unl/P&L when used with 2050 lb.ft. engines. Refer to Product Information Letter #293 for further details.

Brake Components

Cam P	3/Unl/P
Cam P ³	2/100/P
Cam Cast Plus™	2/100/P&L
Cam Q Plus™	3/Unl/P&L
Cam Q Plus™ ²	2/100/P&L
ASA	3/Unl/P
ASA ²	2/100/P
Hubs/Cast Drums and Other Wheel-end Components	1/Unl/P
Hydraulic Disc Brakes	1/Unl/P
All Other Brakes	1/Unl/P
X30™ Drums ¹	12-Years or Wearable Life/P
EX Air Disc Brake	2/100/P&L

¹ Based on stamped wear diameter max.

² Applies to City Bus, Trolley, Shuttle Bus and Airport Shuttle only.

³ Warranty for all non-Meritor ASAs supplied by Meritor for all Heavy Service vocations is 1/100/P.

Transfer Cases – 1/Unl/P

MTC-4208	MTC-4213	T-2119
MTC-4210	T-2111	T-2120

Rear Drive Tandem – 3/Unl/P&L

RT-40-160/P/A ³
RT-46-160/P/A ^{1,3}
RT-46-164EH/P/A ^{2,3}
RT-50-160/P/A ³

¹ U.S. only. Canadian warranty = 1/Unl/P for combination vehicles only.

² Axle model designated will vary according to options and variations specified on these axles. Contact Meritor Axle Applications Engineering for details.

³ Each vehicle must have a Request for Application Recommendation (RAR) approved by Meritor prior to vehicle build. All RARs must identify the chassis number or VIN. Refer to Product Information Letter #303 and #396 for further details.

Meritor Tire Inflation System by PSI

MTIS Components	3/500/P&L
-----------------	-----------

Trailer Air Suspension Systems

MTA (Trailing Arm)	
Major Structural Components ¹	5/Unl/P, 1/Unl/L
Height Control Valve	1/Unl/P&L
Shock Absorbers	2/Unl/P&L
Air Springs	2/Unl/P, 1/Unl/L
Bushings ¹	5/Unl/P, 3/Unl/L

¹ Raw wood applications 3/Unl/P, 1/Unl/L

(For axle and ABS coverage, refer to appropriate product warranties.)

Center Non-drive Axles – 2/Unl/P&L

MC26000
71063
79063

Trailer Axles

Beam and Brackets ¹	5/Unl/P, 1/Unl/L
Wheel End Systems ²	
Standard System ³	1/Unl/P&L

¹ 9000 Series is 3/Unl/P, 1/Unl/L.

² Includes hub, wheel seals and wheel bearings—all systems require annual inspections and proper documentation to ensure full coverage.

³ When installed by Meritor.

(For brake components and ABS coverage, refer to appropriate product warranties.)

OFF-HIGHWAY SERVICE WARRANTY INFORMATION

Industrial And Off-Highway Service Vehicles

- | | | | |
|-----------------------|--------------------------|-----------------------|--------------------|
| ■ Load-On/Load-Off | ■ Yard Jockey | ■ Specialized Mining | ■ Rail Car Mover |
| ■ Port Tractor | ■ All-Terrain Crane | ■ Excavator | ■ Loader |
| ■ Rail Yard Spotter | ■ Rough Terrain Crane | ■ Compactor | ■ Tow Tractor |
| ■ Roll-On/Roll-Off | ■ Forestry | ■ Fertilizer Spreader | ■ Pushback Tractor |
| ■ Stevedoring Tractor | ■ Material Handling | ■ Snow Blower | |
| ■ Trailer Spotter | ■ Specialized Heavy Haul | ■ Mining | |

Industrial And Off-Highway Service Typically Is

- Low mileage operation
- Low speed vehicle speed restriction
- Vehicles are **not** typically licensed for highway use
- Six (6) starts/stops per mile (typical)

Coverage under Meritor's warranty requires that the application of products be properly approved pursuant to OEM and Meritor approvals. Refer to TP-9441 for axles, TP-12126 for drivelines, and/or contact Meritor regarding specific application approval questions on any product line.

Drive Steer Axles – 1/Unl/P

MOR MOX MOC

Front Non-Drive Steer Axles – 1/Unl/P

FF - 941	FL - 943	MFS-16-143A-N
FF - 943	MFS-12-143A-N	MFS-18-133A-N
FF - 961	MFS-12-144A-N	MFS-20-133A-N
FF - 966	MFS-13-143A-N	MON-ZO FAMILY
FG - 941	MFS-13-144A-N	
FG - 943	MFS-14-143A-N	
FL - 941	MFS-16-122A-N	

Planetary Axles – 1/Unl/P

MOR MOX MOC MOT

Rear Drive Single Axles – 1/Unl/P

RS-23-186	MS-30-616	MS-35-380
RS-23-380	RS-30-185	
RS-24-160	RS-30-380	

Drivelines – 1/Unl/P

RPL RN MXL

Rear Drive Tandem Axles – 2/Unl/P

MT-44-14X/P	MT-70-380	RT-46-164EH/P
MT-52-616	RT-44-145/P	RT-50-160/P
MT-58-616	RT-46-160/P	RZ-166

Brake Components

Cam P	3/Unl/P
Cam Q Plus™	3/Unl/P&L
ASA	3/Unl/P
Hubs/Cast Drums and Other Wheel-end Components	1/Unl/P
Hydraulic Disc Brakes	1/Unl/P
All Other Brakes	1/Unl/P

OFF-HIGHWAY SERVICE WARRANTY INFORMATION

Industrial And Off-Highway Service Vehicles

- | | | | |
|-----------------------|--------------------------|-----------------------|--------------------|
| ■ Load-On/Load-Off | ■ Yard Jockey | ■ Specialized Mining | ■ Rail Car Mover |
| ■ Port Tractor | ■ All-Terrain Crane | ■ Excavator | ■ Loader |
| ■ Rail Yard Spotter | ■ Rough Terrain Crane | ■ Compactor | ■ Tow Tractor |
| ■ Roll-On/Roll-Off | ■ Forestry | ■ Fertilizer Spreader | ■ Pushback Tractor |
| ■ Stevedoring Tractor | ■ Material Handling | ■ Snow Blower | |
| ■ Trailer Spotter | ■ Specialized Heavy Haul | ■ Mining | |

Industrial And Off-Highway Service Typically Is

- Low mileage operation
- Low speed vehicle speed restriction
- Vehicles are not typically licensed for highway use
- Six (6) starts/stops per mile (typical)

Coverage under Meritor's warranty requires that the application of products be properly approved pursuant to OEM and Meritor approvals. Refer to TP-9441 for axles, TP-12126 for drivelines, and/or contact Meritor regarding specific application approval questions on any product line.

Drive Steer Axles – 1/Unl/P

MOR MOX MOC

Front Non-Drive Steer Axles – 1/Unl/P

FF - 941	FL - 943	MFS-16-143A-N
FF - 943	MFS-12-143A-N	MFS-18-133A-N
FF - 961	MFS-12-144A-N	MFS-20-133A-N
FF - 966	MFS-13-143A-N	MON-ZO FAMILY
FG - 941	MFS-13-144A-N	
FG - 943	MFS-14-143A-N	
FL - 941	MFS-16-122A-N	

Planetary Axles – 1/Unl/P

MOR MOX MOC MOT

Rear Drive Single Axles – 1/Unl/P

RS-23-186	MS-30-616	MS-35-380
RS-23-380	RS-30-185	
RS-24-160	RS-30-380	

Drivelines – 1/Unl/P

RPL RN MXL

Rear Drive Tandem Axles – 2/Unl/P

MT-44-14X/P	MT-70-380	RT-46-164EH/P
MT-52-616	RT-44-145/P	RT-50-160/P
MT-58-616	RT-46-160/P	RZ-166

Brake Components

Cam P	3/Unl/P
Cam Q Plus™	3/Unl/P&L
ASA	3/Unl/P
Hubs/Cast Drums and Other Wheel-end Components	1/Unl/P
Hydraulic Disc Brakes	1/Unl/P
All Other Brakes	1/Unl/P



TERMS AND CONDITIONS

Coverage Exclusions

Product Description

All

The cost of any repairs, replacements or adjustments to a covered component (1) associated with noise; (2) resulting from the use or installation of non-genuine Meritor components or materials; (3) due to vibration associated with improper operation or misapplication of drivetrain components; and (4) damage resulting from corrosion.

Front Axles

King Pin Bushings.

Rear Axles

Self-contained traction equalizers and oil filters. The use of NoSPIN differentials will result in the exclusion of axle shafts from warranty considerations. NoSPIN is a product of Eaton.

ASA

Boot and bushing. Bent, broken, over-torqued, missing or otherwise damaged pawl assemblies.

Cam Brake

Brake lining wear and brake shoe "rust-jacking."

Disc Brake

Pad wear, rotor wear.

Coverage Limitations

Product Description

All

Any claim beyond 60 days from date of repair will not be accepted or honored under this warranty program. Products purchased on an incomplete vehicle (glider) are limited to one year, unlimited miles parts only (1/Unl/P).

Front Axles

Tie rod and tie rod ends limited to 3-year/300,000-mile or published vocational coverage, whichever is less. Wheel seals, gaskets and wheel bearings are covered for 1 year/unlimited miles if the wheel end equipment is supplied and assembled by Meritor.

Rear Axles

Pinion and through shaft seals limited to 3-year/300,000-mile or published vocational coverage, whichever is less, if yoke is installed by Meritor. If yoke is not installed by Meritor, then Meritor does not warrant pinion seals. Wheel seals, gaskets and wheel bearings are covered for 1 year/unlimited miles if the wheel end equipment is supplied and assembled by Meritor.

Rear Axles

The Meritor® breather part number A-2297-C-8765 with A-3196-J-1336 hose must be used for eligibility of any potential warranty consideration relating to contamination and/or loss of lube in axles.

Cam Brake

Limited to bracket, brake spider and camshaft structural integrity.

X30

Wearable life is up to the discard diameter of the drum.

Disc Brake

Warranty coverage for boots, seals, bushings and pins is 2/200/P. Warranty coverage for pads is 1/100/P.

Warranty coverage on vehicles with 1,850 lb-ft engine torque and over may be reduced on individual drivetrain components. Contact your Meritor representative for specific details.

TERMS AND CONDITIONS

(1) What is Covered by this Commercial Warranty?

Meritor Inc. warrants to the owner ("Owner") that the components listed in this publication, which have been installed by an Original Equipment Manufacturer ("OEM") as original equipment in vehicles licensed for on-highway use, will be free from defects in material and workmanship. This warranty coverage begins only after the expiration of the OEM's vehicle warranty for the applicable covered components. Warranty coverage ends at the expiration of the applicable time period from the date of vehicle purchase by the first Owner, or, the applicable mileage limitation, whichever occurs first. Duration of coverage varies by component and vocation as detailed elsewhere in this warranty statement.

Some components are warranted for parts only and the Owner must pay any labor costs associated with the repair or replacement of the component. Other components are warranted for both parts and reasonable labor to repair or replace the subject component. Components (whether new, used or remanufactured) installed as replacements under this warranty are warranted only for the remainder of the original period of time or mileage under the original warranty.

For certain components, coverage requires the use of specific extended drain interval or synthetic lubricants. For further information about lubrication and maintenance, see Meritor publication Maintenance Manual Number 1 and the applicable Meritor maintenance manual for the product in question. Other conditions and limitations applicable to this warranty are detailed below.

(2) Designation of Vocational Use Required.

To obtain warranty coverage, each Owner must notify Meritor through the OEM new truck and/or trailer dealer of the intended vocational use of the vehicle into which the Meritor components have been incorporated prior to the vehicle in-service date. This notification may be accomplished by registering the vehicle through your OEM new truck and/or trailer dealer or with Meritor directly. Failure to notify Meritor of (I) the intended vocational use of the vehicle or (II) a change in vocational use from that which was originally designated, will result in the application of a one year, unlimited mileage, parts only warranty (1/Unl/P) from the initial in-service date.

A second Owner and each subsequent Owner must also notify Meritor as to the intended vocational use of the vehicle. This notification can be sent directly to Meritor or through the OEM new truck and/or trailer dealer. The duration and mileage coverage of this warranty cannot exceed the coverage extended to the first Owner after his or her initial designation of vocational use.

Coverage under Meritor's warranty requires that the application of products be properly approved pursuant to OEM and Meritor approvals. Refer to TP-9441 for axles, SP-8320 for trailer axles, TP-12126 for drivelines, and/or contact Meritor regarding specific application approval questions on any product line.

(3) What is the Cost of this Warranty?

There is no charge to the Owner for this warranty.

(4) What is not Covered by this Warranty?

This warranty does not cover normal wear and tear; nor does it cover a component that fails, malfunctions or is damaged as a result of (I) improper installation, adjustment, repair or modification (including the use of unauthorized attachments or changes or modification in the vehicle's configuration, usage, or vocation from that which was originally approved by Meritor), (II) accident, natural disaster, abuse, or improper use (including loading beyond the specified maximum vehicle weight or altering engine power settings to exceed the axle and/or driveline capacity), or (III) improper or insufficient maintenance (including deviation from approved lubricants, change intervals, or lube levels). This warranty does not cover any component or part that is not sold by Meritor. For vehicles that operate full or part time outside of the United States and Canada, a one year, unlimited mileage, parts only warranty (1/Unl/P) will apply.

(5) Remedy.

The exclusive remedy under this warranty shall be the repair or replacement of the defective component at Meritor's option. Meritor reserves the right to require that all applicable failed materials are available and/or returned to Meritor for review and evaluation.

(6) Disclaimer of Warranty.

THIS WARRANTY IS EXPRESSLY IN LIEU OF ALL OTHER WARRANTIES OR CONDITIONS, EXPRESSED, IMPLIED OR STATUTORY INCLUDING ANY IMPLIED WARRANTY OF MERCHANTABILITY OR FITNESS FOR PARTICULAR PURPOSE.

(7) Limitation of Remedies.

In no event shall Meritor be liable for special, incidental, indirect, or consequential damages of any kind or under any legal theory, including, but not limited to, towing, downtime, lost productivity, cargo damage, taxes, or any other losses or costs resulting from a defective covered component.

(8) To Obtain Service.

If the Owner discovers within the applicable coverage period a defect in material or workmanship, the Owner must promptly give notice to either Meritor or the dealer from which the vehicle was purchased. To obtain service, the vehicle must be taken to any participating OEM new truck and/or trailer dealer or authorized Meritor service location. The dealer will inspect the vehicle and contact Meritor for an evaluation of the claim. When authorized by Meritor, the dealer will repair or replace during the term of this warranty any defective Meritor component covered by this warranty.

(9) Entire Agreement.

This is the entire agreement between Meritor and the Owner about warranty and no Meritor employee or dealer is authorized to make any additional warranty on behalf of Meritor. This agreement allocates the responsibilities for component failure between Meritor and the Owner.

Vehicle models, brands and names depicted herein are the property of their respective owners, and are not in any way associated with Meritor, Inc., or its affiliates.



Meritor Heavy Vehicle Systems, LLC
2135 West Maple Road
Troy, Michigan 48084 USA

For more information:
call Ontrac at 866-668-7221
or visit meritor.com

©2013 Meritor, Inc.
Litho in USA, SP-95155
Revised 10-13 (47865/11900)

TRW COMMERCIAL STEERING SYSTEMS
800 HEATH STREET
LAFAYETTE, INDIANA 47904



PRODUCT WARRANTY

- I. WARRANTY:** The Commercial Steering Systems group of TRW, Inc., hereinafter referred to as "CSS", warrants that each new product supplied by CSS to its customer, when properly installed, used and maintained, shall be free from defect in material and workmanship for the period specified below:
- (A) CSS Product installed in **New On-highway Motor Vehicle:**
- Within twelve (12) months after date of delivery of such vehicle to the original retail purchaser, or before such vehicle has been driven one hundred thousand (100,000) miles, whichever event shall first occur.
- (B) CSS Product installed in **New Agricultural, Turf, Industrial, or Construction Vehicles and Related Equipment**
- Within twelve (12) months after date of delivery of such vehicle/equipment to the original retail purchaser or before such vehicle/equipment has been operated for two thousand (2000) hours or fifty thousand (50,000) miles, whichever occurs first.
- (C) CSS Product installed in **New End Product, Not Specifically Mentioned in Classifications (A) or (B) Above and All Other Off-Highway/Severe Applications:**
- Within six (6) months after date of delivery of the original equipment manufacturer's end product to the original retail purchaser.
- II. REMEDY:** Customer's sole remedy under the foregoing warranty is limited to correction by means of repair, replacement or issuance of credit, at the option of CSS, of any product which is:
- (A) Returned to CSS within the specified warranty time period, with prior notice to, and the written consent of, CSS, with transportation and handling charges prepaid, together with a statement describing the alleged defect, the part number, model number and application, and mileage or hours of use of such product; and
- (B) Upon examination, determined by CSS not to conform to the warranty.
- III.** Any product which is repaired or replaced under this warranty will be returned to customer prepaid. Disposition of any product determined not to be covered by this warranty will be at the customer's expense.
- IV.** CSS will not be liable for any repairs, replacements, or adjustments to any product or any cost of labor performed by or at the request of customer without the express prior written consent of CSS.
- V. EXCEPTIONS:** The provision of this warranty shall not apply to any CSS product which is used for a purpose for which it is not designed, or which shall have been repaired or altered in any way, or which has been subject to misuse, negligence or accident, neglect of normal maintenance services, so as, in the judgement of CSS to adversely affect its performance and reliability. In no case will the CSS warranty exceed the standard published warranty of its customer in terms of time and/or distance. In all events, the CSS warranty will expire thirty (30) months after the date of manufacture as stamped on the Product. In the case of hydraulic equipment, operation with unapproved fluid or temperatures voids this warranty.
- VI. EXCLUSION OF ALL OTHER REMEDIES AND LIMITATION OF LIABILITY:** Customer's sole and exclusive remedy under the foregoing warranty shall be for the repair, replacement or issuance of credit with respect to a defective product, as set forth and described above. Other provisions hereof notwithstanding, CSS shall not be liable to Customer, or any successor in interest, beneficiary or assignee of Customer, based upon any claim against CSS, whether in contract, warranty, negligence, strict liability, indemnity or otherwise, for any special, consequential, incidental or other damages relating in any way to the design, manufacture, sale, installation or other use of any product purchased from CSS.
- VII. EXCLUSION OF ALL OTHER WARRANTIES: THE FOREGOING WARRANTY IS THE EXCLUSIVE WARRANTY BY CSS AND IS IN LIEU OF AND EXCLUDES ALL OTHER WARRANTIES AND REPRESENTATIONS, WHETHER ORAL, WRITTEN, EXPRESSED, IMPLIED OR STATUTORY, INCLUDING BUT NOT LIMITED TO ANY WARRANTY OF MERCHANTABILITY OR FITNESS FOR A PARTICULAR PURPOSE.**

MERITOR® COMMERCIAL VEHICLE SYSTEMS

**WARRANTY / MODEL
YEAR 2013 VEHICLES**



MERITOR®

WARRANTY INFORMATION CONTENTS

Effective Model Year 2013 Vehicles

Linehaul	4-5
General Service.....	6-7
Heavy Service	8-9
Off-Highway Service	10
Terms and Conditions	11

How to Read Warranty Coverage

Number of Years	Mileage (in thousands) Unl=Unlimited	P=Parts Only P&L=Parts & Labor
-----------------	---	-----------------------------------

Models or components that are approved for use by Meritor's vocational guidelines contained in Meritor Publication TP-9441 for axles, SP-8320 for trailer axles, which are not specifically listed, are warranted for one year, unlimited miles, parts only (1/Unl/P).

HEAVY SERVICE WARRANTY INFORMATION

HEAVY SERVICE VEHICLES

- Airport Rescue Fire (ARF)
- Airport Shuttle
- Asphalt Truck
- Block Truck
- Bottom Dump Trailer
- Cementing Vehicle
- City Bus
- Commercial Pick-Up
- Concrete Pumper
- Construction Material Hauler
- Crash Fire Rescue (CFR)
- Mixer
- Demolition
- Drill Rig
- Dump
- Emergency Service
- Equipment Hauling
- Flatbed Trailer Hauler
- Flatbed Truck
- Fracturing Truck
- Front Loader
- Geophysical Exploration
- Hopper Trailer Combinations
- Landscaping Truck
- Liquid Waste Hauler
- Log Hauling
- Lowboy
- Michigan Special Gravel Trains
- Michigan Special Log Hauler
- Michigan Special Steel Hauler
- Michigan Special Waste Vehicle
- Municipal Dump
- Rapid Intervention Vehicle (RIV)
- Rear Loader
- Recycling Truck
- Residential Pick-Up
- Rigging Truck
- Roll-Off
- Scrap Truck
- Semi-End Dump
- Sewer/Septic Vacuum
- Shuttle Bus
- Side Loader
- Snowplow/Snowblower
- Steel Hauling
- Tanker
- Tank Truck
- Tractors with Pole Trailers
- Tractor/Trailer with Jeeps
- Transfer Dump
- Transfer Vehicle
- Transit Bus
- Trolley
- Utility Truck
- Winch Truck

HEAVY SERVICE TYPICALLY IS

- Moderate mileage operation (less than 60,000 miles per year)
- On/Off road vocations (10% or more off-road)
- Moderate to frequent stops/starts (up to 10 stops per mile)

Coverage under Meritor's warranty requires that the application of products be properly approved pursuant to OEM, Meritor, Meritor WABCO, and ZF engineering approvals. Refer to TP-9441 for axles, SP-8320 for trailer axles, and/or contact Meritor regarding specific application approval questions on any product line.

FRONT DRIVE/NON-DRIVE STEER AXLES – 2/UNL/P&L

FD-965	FG-941	MFS-6-162B	MFS-10-143A-N	MFS-16-122A-N	MX-16-120
FF-941	FG-943	MFS-6-162C	MFS-10-144A-N	MFS-16-143A-N	MX-17-140
FF-942	FH-941	MFS-7-113C-N	MFS-12-143A-N	RF-16-145	MX-19-140
FF-943	FH-945	MFS-7-153C-N	MFS-12-144A-N	MFS-18-133A-N	MX-21-140
FF-944	FH-946	MFS-7-163C-N	MFS-12-155	MFS-20-133A-N	MX-21-160
FF-946	FL-941	MFS-8-113B-N	MFS-13-143A-N	RF-21-160	MX-23-160
FF-961	FL-943	MFS-8-153B-N	MFS-13-144A-N	MX-10-120	MX-23-810
FF-966	MFS-6-151A-N	MFS-8-163B-N	MFS-13-155	MX-12-120	
FF-967	MFS-6-153B	MFS-10-122A	MFS-14-143A-N	MX-14-120	

CLUTCHES

15.5" HD Clutch ¹	1/100/P&L
15.5" TwinXTend	1/100/P&L
17" FreedomLine Clutch	1/100/P&L

¹ Products with an in-service date prior to 11/01/02 warranted by Meritor Clutch Company.

DRIVELINES – 1/UNL/P&L

RPL	92N	RN	MXL
-----	-----	----	-----

REAR DRIVE SINGLE AXLES – 2/UNL/P&L

MS-10-113	RC-23-160	MS-26-616
RS-13-120	RH-23-160	RS-26-185/380
RS-15-120	RS-23-160	MS-30-616
MS-17-14X	RS-23-160	RH-30-185
RS-17-144/145/A	RC-23-161	RS-30-185/380
MS-19-14X	RH-23-161	MS-35-380
RS-19-144	RS-23-161	RS-38-380
MS-21-114	RS-23-186/380	RC-25-160
MS-21-14X	RC-23-162	RC-26-633
RS-21-145	RC-23-165	MT-58-616
RS-21-145/A	RS-24-160	71162
RS-21-160	RS-25-160	71163
RC-22-145	RH-26-185	

OFF-HIGHWAY SERVICE WARRANTY INFORMATION

INDUSTRIAL AND OFF-HIGHWAY SERVICE VEHICLES

- Load-On/Load-Off
- Port Tractor
- Rail Yard Spotter
- Roll-On/Roll-Off
- Stevedoring Tractor
- Trailer Spotter
- Yard Jockey
- All-Terrain Crane
- Rough Terrain Crane
- Forestry
- Material Handling
- Specialized Heavy Haul
- Specialized Mining
- Excavator
- Compactor
- Fertilizer Spreader
- Snow Blower
- Mining
- Rail Car Mover
- Loader
- Tow Tractor
- Pushback Tractor

INDUSTRIAL AND OFF-HIGHWAY SERVICE TYPICALLY IS

- Low mileage operation
- Low speed vehicle speed restriction
- Vehicles are **not** typically licensed for highway use
- Six (6) starts/stops per mile (typical)

Coverage under Meritor's warranty requires that the application of products be properly approved pursuant to OEM, Meritor, Meritor WABCO, and ZF engineering approvals. Refer to TP-9441 for axles and/or contact Meritor regarding specific application approval questions on any product line.

DRIVE STEER AXLES – 1/UNL/P

MOR	MOX	MOC
-----	-----	-----

FRONT NON-DRIVE STEER AXLES – 1/UNL/P

FF - 941	FL - 943	MFS-16-143A-N
FF - 943	MFS-12-143A-N	MFS-18-133A-N
FF - 961	MFS-12-144A-N	MFS-20-133A-N
FF - 966	MFS-13-143A-N	MON-ZO FAMILY
FG - 941	MFS-13-144A-N	
FG - 943	MFS-14-143A-N	
FL - 941	MFS-16-122A-N	

PLANETARY AXLES – 1/UNL/P

MOR	MOX	MOC	MOT
-----	-----	-----	-----

REAR DRIVE SINGLE AXLES – 1/UNL/P

RS-23-186	MS-30-616	MS-35-380
RS-23-380	RS-30-185	
RS-24-160	RS-30-380	

DRIVELINES – 1/UNL/P

RPL	RN	MXL
-----	----	-----

REAR DRIVE TANDEM AXLES – 1/UNL/P

MT-44-14X/P	MT-70-380	RT-46-164EH/P
MT-52-616	RT-44-145/P	RT-50-160/P
MT-58-616	RT-46-160/P	

BRAKE COMPONENTS

Cam P	3/Unl/P
Cam Q Plus™	3/Unl/P&L
ASA	3/Unl/P
Hubs/Cast Drums and Other Wheel-end Components	1/Unl/P
Hydraulic Disc Brakes	1/Unl/P
All Other Brakes	1/Unl/P
LX500 Feature ¹	1/Unl/P

¹ Includes: bushing, seal, cam and ASA.

² Based on stamped wear diameter max.

MERITOR WABCO COMPONENTS¹

ABS (Anti-Lock Braking System) Air/Hydraulic	3/300/P&L
Air Dryers (ALL)	1/100/P&L
Leveling Valves	1/Unl/P&L
Air Brake Valves	1/100/P
Clutch Controls	2/200/P&L
Air Compressors ²	1/100/P&L
Actuator	1/100/P&L

¹ Warranted by Meritor WABCO Vehicle Control Systems.

² WABCO compressors installed on Cummins, Mercedes, and DDC engines are not warranted or serviced by Meritor WABCO. Please contact your respective dealer/distributor of those engines for warranty and servicing.

TERMS AND CONDITIONS

COVERAGE EXCLUSIONS:

Product Description

All

The cost of any repairs, replacements or adjustments to a covered component (1) associated with noise; (2) resulting from the use or installation of non-genuine Meritor components or materials; (3) due to vibration associated with improper operation or misapplication of drivetrain components; and (4) damage resulting from corrosion.

Front Axles

King Pin Bushings.

Rear Axles

Self-contained traction equalizers and oil filters. The use of NoSPIN differentials will result in the exclusion of axle shafts from warranty considerations. NoSPIN is a product of Eaton.

Clutch

Friction face and mating surface of center and pressure plate, wear pads and clutch brake.

ASA

Boot and bushing. Bent, broken, over-torqued, missing or otherwise damaged pawl assemblies.

ABS, Electronic Stability Control (ESC), Roll Stability Control (RSC) and OnGuard

Cut, broken, chaffed or otherwise damaged cable wires. Damaged sensors from removal when seized in block, or sensor adjustments/alignments. Valve failures due to contamination in air system. E.C.U. failures due to excessive over-voltage conditions.

Air Dryers

Mounting brackets (see vehicle OEM). Desiccant cartridge housing only.

Air System Components

Gladhand seals, dash valve knobs, valve actuation handles, treadles, pedals. Water and other contamination damage that is due to the use of a non-genuine air dryer cartridge will not be covered.

Cam Brake

Brake lining wear and brake shoe "rust-jacking."

Disc Brake

Pad wear, rotor wear.

COVERAGE LIMITATIONS:

Product Description

All

Any claim beyond 60 days from date of repair will not be accepted or honored under this warranty program.

Front Axles

Tie rod and tie rod ends limited to 3-year/300,000-mile or published vocational coverage, whichever is less. Wheel seals, gaskets and wheel bearings are covered for 1 year/unlimited miles if the wheel end equipment is supplied and assembled by Meritor.

Rear Axles

Pinion and through shaft seals limited to 3-year/300,000-mile or published vocational coverage, whichever is less, if yoke is installed by Meritor. If yoke is not installed by Meritor, then Meritor does not warrant pinion seals. Wheel seals, gaskets and wheel bearings are covered for 1 year/unlimited miles if the wheel end equipment is supplied and assembled by Meritor.

Rear Axles

The Meritor® breather part number A-2297-C-8765 with A-3196-J-1336 hose must be used for eligibility of any potential warranty consideration relating to contamination and/or loss of lube in axles.

Cam Brake

Limited to bracket, brake spider and camshaft structural integrity.

X30

Wearable life is up to the discard diameter of the drum.

Disc Brake

Warranty coverage for boots, seals, bushings and pins is 2/200/P. Warranty coverage for pads is 1/100/P.

Warranty coverage on vehicles with 1,850 lb-ft engine torque and over may be reduced on individual drivetrain components. Contact your Meritor representative for specific details.

TERMS AND CONDITIONS

(1) What is Covered by this Commercial Warranty?

Meritor Inc. warrants to the owner ("Owner") that the components listed in this publication, which have been installed by an Original Equipment Manufacturer ("OEM") as original equipment in vehicles licensed for on-highway use, will be free from defects in material and workmanship. This warranty coverage begins only after the expiration of the OEM's vehicle warranty for the applicable covered components. Warranty coverage ends at the expiration of the applicable time period from the date of vehicle purchase by the first Owner, or, the applicable mileage limitation, whichever occurs first. Duration of coverage varies by component and vocation as detailed elsewhere in this warranty statement.

Some components are warranted for parts only and the Owner must pay any labor costs associated with the repair or replacement of the component. Other components are warranted for both parts and reasonable labor to repair or replace the subject component. Components (whether new, used or remanufactured) installed as replacements under this warranty are warranted only for the remainder of the original period of time or mileage under the original warranty.

For certain components, coverage requires the use of specific extended drain interval or synthetic lubricants. For further information about lubrication and maintenance, see Meritor publication Maintenance Manual Number 1 and the applicable Meritor maintenance manual for the product in question. Other conditions and limitations applicable to this warranty are detailed below.

(2) Designation of Vocational Use Required.

To obtain warranty coverage, each Owner must notify Meritor through the OEM new truck and/or trailer dealer of the intended vocational use of the vehicle into which the Meritor components have been incorporated prior to the vehicle in-service date. This notification may be accomplished by registering the vehicle through your OEM new truck and/or trailer dealer or with Meritor directly. Failure to notify Meritor of (I) the intended vocational use of the vehicle or (II) a change in vocational use from that which was originally designated, will result in the application of a one year, unlimited mileage, parts only warranty (1/Unl/P) from the initial in-service date.

A second Owner and each subsequent Owner must also notify Meritor as to the intended vocational use of the vehicle. This notification can be sent directly to Meritor or through the OEM new truck and/or trailer dealer. The duration and mileage coverage of this warranty cannot exceed the coverage extended to the first Owner after his or her initial designation of vocational use.

Coverage under Meritor's warranty requires that the application of products be properly approved pursuant to OEM, Meritor, Meritor-WABCO, and ZF engineering approvals. Refer to TP-9441 for axles, SP-8320 for trailer axles, and/or contact Meritor regarding specific application approval questions on any product line.

(3) What is the Cost of this Warranty?

There is no charge to the Owner for this warranty.

(4) What is not Covered by this Warranty?

This warranty does not cover normal wear and tear; nor does it cover a component that fails, malfunctions or is damaged as a result of (I) improper installation, adjustment, repair or modification (including the use of unauthorized attachments or changes or modification in the vehicle's configuration, usage, or vocation from that which was originally approved by Meritor), (II) accident, natural disaster, abuse, or improper use (including loading beyond the specified maximum vehicle weight or altering engine power settings to exceed the transmission, axle, driveline, and/or clutch torque capacity), or (III) improper or insufficient maintenance (including deviation from approved lubricants, change intervals, or lube levels). This warranty does not cover any component or part that is not sold by Meritor. For vehicles that operate full or part time outside of the United States and Canada, a one year, unlimited mileage, parts only warranty (1/Unl/P) will apply.

(5) Remedy.

The exclusive remedy under this warranty shall be the repair or replacement of the defective component at Meritor's option. Meritor reserves the right to require that all applicable failed materials are available and/or returned to Meritor for review and evaluation.

(6) Disclaimer of Warranty.

THIS WARRANTY IS EXPRESSLY IN LIEU OF ALL OTHER WARRANTIES OR CONDITIONS, EXPRESSED, IMPLIED OR STATUTORY INCLUDING ANY IMPLIED WARRANTY OF MERCHANTABILITY OR FITNESS FOR PARTICULAR PURPOSE.

(7) Limitation of Remedies.

In no event shall Meritor be liable for special, incidental, indirect, or consequential damages of any kind or under any legal theory, including, but not limited to, towing, downtime, lost productivity, cargo damage, taxes, or any other losses or costs resulting from a defective covered component.

(8) To Obtain Service.

If the Owner discovers within the applicable coverage period a defect in material or workmanship, the Owner must promptly give notice to either Meritor or the dealer from which the vehicle was purchased. To obtain service, the vehicle must be taken to any participating OEM new truck and/or trailer dealer or authorized Meritor service location. The dealer will inspect the vehicle and contact Meritor for an evaluation of the claim. When authorized by Meritor, the dealer will repair or replace during the term of this warranty any defective Meritor component covered by this warranty.

(9) Entire Agreement.

This is the entire agreement between Meritor and the Owner about warranty and no Meritor employee or dealer is authorized to make any additional warranty on behalf of Meritor. This agreement allocates the responsibilities for component failure between Meritor and the Owner.



Meritor Heavy Vehicle Systems, LLC

2135 West Maple Road
Troy, Michigan 48084 USA

For more information:
866-OnTrac1 (866-668-7221)
meritor.com

Litho in USA
©2012 Meritor, Inc.
SP-95155 Revised 06-12 (47865/11900)



Pierce E-coating Process

Advantages

Today, E-coating and galvanizing are two of the most common processes used for corrosion protection in the fire apparatus industry. These processes have proven to be superior to others in regards to their corrosion resistance, resulting in a higher degree of reliability and longer service life. And, while it's true both E-Coating and galvanizing have excellent physical properties that increase the corrosion resistance capabilities of the fire apparatus, differences between the processes have come to light over the years. These differences have driven the preference towards E-Coating for many applications involving automotive, industrial machinery, and fire apparatus.

A few of the differences are:

Uniform Coating

E-Coating allows the frame rails to be painted. Pierce Manufacturing has designed their frame rails to utilize an e-coating process that still allows for the frame rails to be painted job color or any color the customer chooses. The E-Coat process will allow for a uniform finish free of sags, runs, or drips.

Galvanized coating is a sacrificial coating. Zinc will oxidize if not covered and will leave streaks of white versus red oxidation from steel.

Coverage

E-coating offers a uniform coating (1-2 mils or .001 - .002 inches) with an equal layer across the length of the product whereas galvanizing may have varying thickness creating difficulties with assemblies and part fittings. E-coating has the ability to coat inside small, confined areas, most often difficult to reach by galvanizing.

Environmentally Friendly

E-coat has lower volatile organic compounds (VOC's) than any spray application. E-coat contains zero hazardous air pollutants (HAPS). All waste streams from the entire e-coating process are treated on site removing all solids and metals returning the water to acceptable city limits of any and all contaminates. The solids removed are non-hazardous and delivered to the city landfill.