



LEXINGTON

Contract Documents and Technical Specifications

**Man O' War Boulevard
Public Improvement Project
Richmond Road Intersection**

KYTC Item No. 7-428.00

Federal Project No. STPM 3003-290

**LFUCG Bid No. : 12-2018
Prepared by: GRW Engineers**

Set #1
Digital Planroom
www.lynnimaging.com

U



TABLE OF CONTENTS
CONTRACT DOCUMENTS

PART I	ADVERTISEMENT FOR BIDS
PART II	INFORMATION FOR BIDDERS
PART III	FORM OF PROPOSAL
PART IV	GENERAL CONDITIONS
PART V	SPECIAL CONDITIONS
PART VI	CONTRACT AGREEMENT
PART VII	PERFORMANCE AND PAYMENT BONDS
PART VIII	ADDENDA
PART IX	TECHNICAL SPECIFICATIONS AND PLANS

authorized to do business in the Commonwealth of Kentucky and countersigned by a licensed Kentucky Resident Agent, representing the Surety Company. Bid Bonds are not required for bids under \$50,000. A cashier's check or irrevocable letter of credit is an acceptable form of bid security.

8. SUBMISSION OF BIDS

CONTRACTORS shall submit their bids to the Lexington-Fayette Urban County Government, Division of Central Purchasing, Third Floor, 200 East Main Street, Lexington, Kentucky 40507. Bids shall be submitted in a sealed envelope not later than 2:00 p.m. local time, March 30, 2018. Sealed proposals shall be clearly marked on the outside of the container as follows: Company Name and Address, **Bid Invitation Number 12-2018**, and **Man O' War Boulevard Public Improvement Project Richmond Road Intersection** to be opened at 2:00 p.m. local time **March 30, 2018**. Bids are to remain sealed until official Bid closure time. Bids received after the scheduled closing time for receipt of bids will not be considered and will be returned unopened.

9. RIGHT TO REJECT

The Lexington-Fayette Urban County Government reserves the right to reject any and all bids and to waive all informalities and/or technicalities where the best interest of the Lexington-Fayette Urban County Government may be served.

10. NOTIFICATION TO THE LEXINGTON-FAYETTE URBAN COUNTY GOVERNMENT FOR AFFIRMATIVE ACTION PLAN AND CURRENT WORKFORCE

The successful bidder must submit the following to the Lexington-Fayette Urban County Government:

1. Affirmative Action Plan for his/her firm.
2. Current Workforce Analysis Form

Failure to submit this as required herein may result in disqualification of the Bidder from the award of the contract.

All submissions should be directed to:

Lexington-Fayette Urban County Government
Division of Purchasing
200 East Main Street, 3rd Floor, Room 338
Lexington, Kentucky 40507

11. **NOTICE CONCERNING DBE GOAL**

Notice of requirement for Affirmative Action to ensure Equal Employment Opportunities and Disadvantaged Business Enterprises (DBE) contract participation.

The Lexington-Fayette Urban County Government is committed to increasing the participation of minority business enterprises on construction projects, and encourages the use of minority subcontractors and material suppliers. **The Minority Business Enterprise goal for this project is 10% of the Bid Amount.** For assistance in locating Disadvantaged Business Enterprises Subcontractors contact:

Sherita Miller, Division of Central Purchasing
Lexington-Fayette Urban County Government
200 East Main Street, 3rd Floor, Room 338
Lexington, Kentucky 40507
(859) 258-3323

Or

KYTC Office of Civil Rights and Small Business Development
200 Mero Street, Frankfort, KY 40622
(502) 564-3601

12. **PRE-BID MEETING**

No pre-bid meeting is scheduled.

13. **EXCLUDED PARTIES LIST SYSTEM (EPLS/SAM)**

Prior to project being awarded, LFUCG will verify that the contractor is not listed on an "Excluded Parties List System" (suspended or debarred), as identified within the "SAM" site at <http://www.sam.gov>.

The EPLS is an electronic, web-based system that identifies those parties excluded from receiving Federal contracts, certain subcontracts and certain types of Federal financial and non-financial assistance and benefits. The EPLS keeps its user community aware of administrative and statutory exclusions across the entire government, and individuals barred from entering the United States. The user is able to search, view, and download both current and archived exclusions.

EPLS access is available from any personal computer with Internet connectivity and a minimum web browser of Netscape 4.04 Internet Explorer 4.04 or Internet Explorer 4.0 at <http://www.sam.gov>.

END OF SECTION



PART II
INFORMATION FOR BIDDERS

INDEX

1. RECEIPT AND OPENING OF BIDS
2. PREPARATION OF BID
3. SUBCONTRACTS
4. QUALIFICATION OF BIDDER
5. BID SECURITY
6. LIQUIDATED DAMAGES FOR FAILURE TO ENTER INTO CONTRACT
7. TIME OF COMPLETION AND LIQUIDATED DAMAGES
8. EXAMINATION OF CONTRACT DOCUMENTS AND SITE
9. ADDENDA AND INTERPRETATIONS
10. SECURITY FOR FAITHFUL PERFORMANCE
11. POWER OF ATTORNEY
12. TAXES AND WORKMEN'S COMPENSATION
13. LAWS AND REGULATIONS
14. EROSION AND SEDIMENT CONTROL AND PERMITS
15. PREVAILING WAGE LAW AND MINIMUM HOURLY RATES
16. AFFIRMATIVE ACTION PLAN
17. CONTRACT TIME
18. SUBSTITUTION OR "OR-EQUAL" ITEMS
19. ALTERNATE BIDS
20. SIGNING OF AGREEMENT
21. ASSISTANCE TO BE OFFERED TO DBE CONTRACTORS
22. DBE PARTICIPATION GOALS
23. ADDITIONAL PROVISIONS
24. REQUIRED SUBMITTALS
25. LFUCG NON-APPROPRIATION CLAUSE

PART II

INFORMATION FOR BIDDERS

1. **RECEIPT AND OPENING OF BIDS**

The Lexington-Fayette Urban County Government (herein called the OWNER) invites bids from firms on the project described in the Advertisement for Bids. The OWNER will receive bids at the Division of Purchasing, at the time and in the manner set forth in the Advertisement for Bids, and the Bids will then be publicly opened and read aloud. The OWNER may consider informal any bid not prepared and submitted in accordance with the provisions hereof and may waive any informalities or reject any and all bids. Any bid may be withdrawn prior to the scheduled time for the opening of bids or authorized postponement thereof. Any bid received after the time and date specified shall not be considered. No bidder may withdraw a bid within 60 days after the actual time and date of the bid opening, but OWNER may, in its sole discretion, release any bid and return the Bid Security prior to that date.

The Lexington-Fayette Urban County Government assumes no responsibility for bids that are not addressed and delivered as indicated above. Bids that are not delivered to the Division of Central Purchasing by the stated time and date will be rejected.

2. **PREPARATION OF BID**

Each bid must be submitted on the prescribed Form of Proposal. All blank spaces for the bid prices must be filled in, either in ink or typewritten, for both unit prices and extensions. Totals for each bid item must be added to show the total amount of the bid.

Each bid must be submitted in a sealed envelope bearing on the outside the name of the bidder, their address, the name of the project, the invitation number and time and date for which the bid is submitted. Bids must be addressed to the Director of Central Purchasing, Lexington-Fayette Urban County Government, Third Floor, 200 East Main Street, Lexington, Kentucky 40507. If forwarded by mail, the sealed envelope containing the bid must be enclosed in another envelope addressed as specified above.

3. **SUBCONTRACTS**

The bidder is specifically advised that any person, firm, or other party to whom it is proposed to award a subcontract under this Contract must be acceptable to the OWNER. All proposed subcontractors must be identified on the Form of Proposal. Prior to the award of Contract, the OWNER or the OWNER'S representative will advise the CONTRACTOR of the acceptance and approval thereof or of any action necessary to be taken. Should any Subcontractor be rejected by the OWNER, the CONTRACTOR shall present a new name and/or firm to the OWNER at no change in the Contract Price.

4. **QUALIFICATION OF BIDDER**

The OWNER may make such investigations as the OWNER deems necessary to determine the ability of the bidder to perform the Work, and the bidder shall furnish to the OWNER all such information and data for this purpose as the OWNER may request. The OWNER reserves the right to reject any bid if the evidence submitted by, or investigation of, such bidder fails to satisfy the OWNER that such bidder is properly qualified to carry out the obligations of the Contract and to complete the Work contemplated therein. Conditional bids will not be accepted.

In evaluating Bids, OWNER shall consider the qualifications of the BIDDERS, whether or not the Bids comply with the prescribed requirements, and alternatives and unit prices, as requested. OWNER may consider maintenance requirements, performance data, and disruption or damage to private property. It is OWNER'S intent to accept alternatives, if requested by the bid forms, in the order in which they are listed in the Bid Form. The contract, if awarded, will be awarded to the lowest, qualified, responsive BIDDER based upon OWNER'S evaluation which indicates that the award will be in the best interest of OWNER and the general public.

In the event there is any question as to the bidder's qualifications and ability to complete the work, a final determination will be made in accordance with a fair evaluation by the Urban County Government of the above listed elements.

- A. If the OWNER requires filling out a detailed financial statement, the bidder may provide its current certified financial statement(s) for the required time interval.
- B. Corporate firms are required to be registered and in good standing with the requirements and provisions of the Office of the Secretary of State, Commonwealth of Kentucky.
- C. Good standing with Public Works Act - any CONTRACTOR and/or subcontractors in violation of any wage or work act provisions (KRS 337.510 to KRS 337.550) are prohibited by Statutory Act (KRS 337.990) from bidding on or working on any and all public works contracts, either in their name or in the name of any other company, firm or other entity in which he might be interested. No bid from a prime contractor in violation of the Act can be considered, nor will any subcontractor in violation of the Act be approved and/or accepted. The responsibility for the qualifications of the subcontractor is solely that of the prime contractor.
- D. Documents Required of CONTRACTOR - (1) A sworn statement signed by the President or owner of the Company regarding all current work in progress

anywhere; (2) A document showing the percent of completion of each project and the total worth of each project; and (3) Documentation showing the percentage of the DBE employment levels on each project of the Bidder's current work force, and DBE participation levels for Subcontractors.

- E. Optional OWNER Requirements - The OWNER, at its discretion, may require the BIDDER/CONTRACTOR to provide: (1) A current detailed financial statement for a period including up to 3 prior years. (2) Financial security or insurance in amounts and kinds acceptable to the OWNER to meet the financial responsibility requirements for the CONTRACTOR to indemnify the OWNER. (3) Additional information and/or DBE work force data, as well as DBE participation data.

Each bidder agrees to waive any claim it has or may have against the Owner, the Architect/Engineer, and their respective employees, arising out of or in connection with the administration, evaluation, or recommendation of any bid.

- F. Bidders and DBE subcontractors must be prequalified with the Kentucky Transportation Cabinet and possess a Certificate of Eligibility at the time of bid opening. All other subcontractors must be prequalified when accepting subcontracts.
- G. **Prequalified DBE list can be found at:**
<http://transportation.ky.gov/Civil-Rights-and-Small-Business-Development/Pages/Certified-and-Prequalified-DBEs.aspx>

5. BID SECURITY

- A. Each bid must be accompanied by a bid bond prepared on a Form of Bid Bond and attached hereto, duly executed by the bidder as principal and having as surety thereon a surety company approved by the OWNER, in the amount of 5% of the bid. Such bid bond will be returned to the unsuccessful bidder(s) only upon written request to the Director of Central Purchasing within seven (7) days of opening of bids. Bid bond shall be made payable to the Lexington-Fayette Urban County Government. Bid security is not required for projects under \$50,000.
- B. Bonds shall be placed with an agent licensed in Kentucky with surety authorized to do business within the state. When the premium is paid for such coverage, the full commission payable shall be paid to such local agent who shall not divide such commission with any person other than a duly licensed resident local agent.

6. **LIQUIDATED DAMAGES FOR FAILURE TO ENTER INTO CONTRACT**

The successful bidder, upon his failure or refusal to execute and deliver the Contract and bonds required within ten (10) days after he has received notice of the acceptance of his bid, shall forfeit to the OWNER, as liquidated damages for such failure or refusal, the security deposited with his bid.

7. **TIME OF COMPLETION AND LIQUIDATED DAMAGES**

It is mutually agreed by and between the parties hereto that time is of the essence of this Contract, and that there will be sustained by the OWNER damages, monetary and otherwise, in the event of delay in the completion of the Work hereby contracted. The CONTRACTOR will be held responsible to the OWNER for delays in completion of the Work herein contracted beyond the date set for completion. Completion is defined in Section 108.09 of the KDOH Standard Specifications, Current Edition. Such monetary damage shall be deducted from the Contract sum in the amount of SEVEN HUNDRED FIFTY DOLLARS (\$750.00) per calendar day of such delay. If the Work contracted to be done shall not, in good faith, be commenced at the time specified, then the CONTRACTOR together with the Surety or Sureties upon the bond herein provided for, shall be liable for and shall pay to the OWNER all damages sustained by reason of such failure for breach of Contract, and the OWNER may immediately relet the Work involved.

Bidder must agree to commence work on or before a date to be specified in a written "Notice to Proceed" from the OWNER and to fully complete the Project within the time as specified in the Contract. Bidder must agree also to pay liquidated damages, or the sum as specified in the Contract for each consecutive calendar day thereafter as hereinafter provided in the General Conditions.

8. **EXAMINATION OF CONTRACT DOCUMENTS AND SITE**

- A. It is the responsibility of each Bidder before submitting a Bid, to (a) examine the Contract Documents thoroughly, (b) visit the site(s) to become familiar with local conditions that may affect cost, progress, performance or furnishing of the work, (c) consider Federal, State and Local laws and regulations that may affect cost, progress, performance or furnishing of the work, (d) study and carefully correlate Bidder's observations with the Contract Documents, and (e) notify Engineer of all conflicts, errors or discrepancies in the Contract Documents.
- B. Bidders should examine the requirements of Section 4 of the General Conditions for information pertaining to subsurface conditions, underground structures, underground facilities, and availability of lands, easements, and rights-of-way. The completeness of data, presented in the Contract Documents, pertaining to subsurface conditions, underground structures, and underground

facilities for the purposes of bidding or construction is not assured. The Bidder will, at Bidder's own expense, make or obtain any additional examinations, investigations, explorations, tests and studies and obtain any additional information and data which pertain to the physical conditions (surface and subsurface) which may affect cost, progress, performance or furnishing of the Work and which Bidder deems necessary to determine its Bid for performing and furnishing the Work in accordance with the time, price, and other terms and conditions of the Contract Documents. On request in advance, OWNER will provide access to the site to conduct such explorations and tests as each Bidder deems necessary for submission of a bid. Bidder shall fill all holes, clean up and restore the site to its former condition upon completion of such explorations.

- C. The submission of a Bid will constitute an incontrovertible representation by the Bidder that Bidder has complied with every requirement of this paragraph; that without exception the Bid is premised upon furnishing and performing the Work required by the Contract Documents and such means, methods, techniques, sequences or procedures of construction as may be indicated in or required by the Contract Documents; and that the Contract Documents are sufficient in scope and detail to indicate and convey understanding of all terms and conditions for performance and furnishing of the Work.

9. ADDENDA AND INTERPRETATIONS

No interpretation of the meaning of the Contract Documents will be made to any bidder orally. Every request for such interpretation should be in writing addressed to the Director of Central Purchasing, who in turn will have an addendum issued under signature of the Engineer for the Lexington-Fayette Urban County Government, and to be given consideration must be received at least seven (7) days prior to the date fixed for the opening of bids. Any and all such interpretations and any supplemental instructions will be in the form of written addenda to the specifications which, if issued, will be mailed by certified mail with return receipt requested, faxed or emailed to all prospective bidders. Failure of any bidder to receive any such addendum or interpretation shall not relieve such bidder from any obligation under his bid as submitted. All addenda so issued shall become part of the Contract Documents.

10. SECURITY FOR FAITHFUL PERFORMANCE

- A. Simultaneously with his delivery of the executed Contracts, the CONTRACTOR shall furnish a surety bond or bonds as security for the faithful performance of this Contract and for payment of all persons performing labor on the Project under this Contract and furnishing materials in connection with this Contract, as specified in the General Conditions. The surety on such bond

or bonds shall be a duly authorized surety company satisfactory to the OWNER and authorized to do business in the Commonwealth of Kentucky.

- B. All bonds required by this Contract and laws of this State shall be placed with agents licensed in the State of Kentucky. When the premium is paid for such coverages, the full commission shall be paid to such local agent who shall not divide such commission with any person other than a duly licensed resident local agent.
- C. **Contractor shall use standard Performance and Payment Bond forms such as documents provided with this contract book or AIA form A312-1984 (or later).**

11. POWER OF ATTORNEY

Attorney-in-fact who signs bid bonds or contract bonds must file with each bond a certified and effectively dated copy of their power of attorney.

12. TAXES AND WORKMEN'S COMPENSATION

The CONTRACTOR and subcontractor will be required to accept liability for payment of all payroll taxes, sales and use tax, and all other taxes or deductions required by local, state or federal law. Each shall carry Workmen's Compensation Insurance to the full amounts as required by Statutes and shall include the cost of all foregoing items in the proposal. The CONTRACTOR will not otherwise be reimbursed or compensated for such tax payments. The CONTRACTOR is urged to ascertain at his own risk his actual tax liability in connection with the execution or performance of his Contract.

13. LAWS AND REGULATIONS

The bidder's attention is directed to the fact that all applicable state laws, municipal ordinances, and the rules and regulations of all authorities having jurisdiction over construction of the Project shall apply to the Contract throughout, and they will be deemed to be included in the contract, the same as though herein written out in full.

14. EROSION AND SEDIMENT CONTROL AND PERMITS

The CONTRACTOR and Subcontractors performing work on projects on behalf of the OWNER shall also comply with all applicable federal, state, and local environmental regulations and all requirements and conditions set forth in "special" permits including but not limited to Corp of Engineers 404 permits, 401 Water Quality Certifications, Stream Crossing and Floodplain Encroachment Permits as described in Part 4 General Conditions Paragraph 5.17.

15. PREVAILING WAGE LAW AND MINIMUM HOURLY RATES

Federal wage rates and regulations, if required for this Project, will be as described in the Special Conditions and appendices.

16. AFFIRMATIVE ACTION PLAN

The successful Bidder must submit with their bid, the following items to the Urban County Government:

1. Certification of Bid Proposal/DBE – see Part III
2. KYTC DBE Provisions – see Part III
3. DBE Subcontractor Bidders List – see Part III

A Work Force Analysis Form shall be submitted for each Contract. Failure to submit these items as required herein may result in disqualification of the Bidder from award of the Contract.

All submissions should be directed to:

Director, Division of Central Purchasing
Lexington-Fayette Urban County Government
200 East Main Street, Third Floor
Lexington, KY 40507

17. CONTRACT TIME

The number of calendar days within which the Work is to be completed and ready for final payment (the Contract Time) is set forth in the Contract Agreement.

18. SUBSTITUTE OR "OR-EQUAL" ITEMS

The Contract, if awarded, will be on the basis of materials and equipment described in the Drawings or specified in the Specifications without consideration of possible substitute or "or-equal" items. Whenever it is indicated in the Drawings or specified in the Specifications that a substitute or "or-equal" item of material or equipment may be furnished or used by the CONTRACTOR if acceptable to the ENGINEER and OWNER, application for such acceptance will not be considered by the ENGINEER and OWNER until after the effective date of the Agreement. The procedure for submission of any such application by the CONTRACTOR and consideration by the ENGINEER and OWNER is set forth in the General Conditions.

19. ALTERNATE BIDS

Bidders shall submit alternate bids/proposals only if and when such alternate bids/proposals have been specifically requested in an Invitation for Bids. If alternate bids/proposals are requested in an Invitation for Bids, the form of submission of such alternate bid and the conditions under which such alternate bids will be considered for award of a contract will be established in the Invitation.

Any Bidder who submits a bid incorporating an alternate proposal when alternate bids/proposals have not been requested in the Invitation for Bids shall have his/her bid rejected as non-responsive.

Any Bidder who submits a bid incorporating two (2) or more prices for an item or groups of items (unless such method of pricing is requested in the Invitation for Bids), or which imposes conditions for acceptance other than those established in the Invitation for Bids, shall have their bid rejected as non-responsive.

20. SIGNING OF AGREEMENT

When OWNER gives a Notice of Award to the successful Bidder, it will be accompanied by the required number of unsigned counterparts of the Agreement with all other written Contract Documents attached. Within ten days thereafter, CONTRACTOR shall sign and deliver the required number of counterparts of the Agreement and attached documents to OWNER with the required Bonds, Certificate of Insurance, and Power of Attorney. The OWNER will deliver one fully signed counterpart to CONTRACTOR at such time as it has been signed by the Mayor.

21. ASSISTANCE TO BE OFFERED TO DISADVANTAGED BUSINESS ENTERPRISE (DBE) CONTRACTORS

I. Outreach

The Lexington-Fayette Urban County Government (LFUCG) maintains a database of MWDBE contractors and organizations. When a LFUCG construction project is advertised for bidding, notices are sent to companies registered at <https://lexingtonky.ionwave.net>. The notices describe the project and indicate the deadline for submitting bids.

If you wish to be added to the LFUCG MWDBE contractor database, please contact:

Sherita Miller, MBE Liaison
Division of Central Purchasing
Lexington-Fayette Urban County Government
200 East Main Street, Room 338
Lexington, Kentucky 40507
smiller@lexingtonky.gov

II. Eligibility for Bid Bond Assistance

In order to be eligible for any bid bonding assistance, a DBE construction company must be owned or controlled at the level of 51% or more, by a member or members of a minority group or females. Prior to receiving assistance, a statement providing evidence of ownership and control of the company by a member or members of a minority group or females must be signed by the OWNER or corporate officer and by an attorney or accountant and submitted to:

Sherita Miller, MBE Liaison
Division of Central Purchasing
Lexington-Fayette Urban County Government
200 East Main Street, Room 338
Lexington, Kentucky 40507
smiller@lexingtonky.gov

III. Subcontractors

The LFUCG will, upon request, assist prime contractors in the procurement of eligible DBE subcontractors in an effort to achieve the **10% minimum DBE goal**.

For a list of eligible DBE subcontractors please contact:

Sherita Miller, MBE Liaison
Division of Central Purchasing
Lexington-Fayette Urban County Government
200 East Main Street, Room 338
Lexington, Kentucky 40507
smiller@lexingtonky.gov

22. DBE PARTICIPATION GOALS

A. GENERAL

- 1) The LFUCG request all potential contractors to make a concerted effort to include Disadvantaged Business Enterprises (DBE) as subcontractors or suppliers in their bids.
- 2) Toward that end, the LFUCG has established a **10%** of total procurement costs as a Goal for participation of Disadvantaged Businesses Enterprise (DBE) on this contract.
- 3) DBE Subcontractors must be prequalified and certified with the Kentucky Transportation Cabinet at the time of bid if utilized as a DBE meeting the DBE Goal.
- 4) **It is therefore a request of each Bidder to include in its bid, the same goal (10%) for DBE participation and other requirements as outlined in this section.**
- 5) The LFUCG has also established a 3% of total procurement costs as a Goal for participation for of Veteran-Owned Businesses.
- 6) **It is therefore a request of each Bidder to include in its bid, the same goal (3%) for Veteran-Owned participation and other requirements as outlined in this section.**

B. PROCEDURES

- 1) The successful bidder will be required to report to the LFUCG, the dollar amounts of all purchase orders submitted to DBE subcontractors and suppliers for work done or materials purchased for this contract. (See Subcontractor Monthly Payment Report)
- 2) Replacement of a DBE subcontractor or supplier listed in the original submittal must be requested in writing and must be accompanied by documentation of Good Faith Efforts to replace the subcontractor / supplier with another DBE Firm; this is subject to approval by the LFUCG. (See KYTC DBE Substitution Form)
- 3) For assistance in identifying qualified, certified businesses to solicit for potential contracting opportunities, bidders may contact:

- a) The Lexington-Fayette Urban County Government, Division of Central Purchasing (859-258-3320)
- 4) The LFUCG will make every effort to notify interested DBE subcontractors and suppliers of each Bid Package, including information on the scope of work, the pre-bid meeting time and location, the bid date, and all other pertinent information regarding the project.

C. DEFINITIONS

- 1) A Disadvantaged Business Enterprise (DBE) is defined as a business which is certified as being at least 51% owned and operated by persons of African American, Hispanic, Asian, Pacific Islander, American Indian or Alaskan Native Heritage or by one or more Females.

D. OBLIGATION OF BIDDER

- 1) **The bidder shall make a Good Faith Effort to achieve the Participation Goal for DBE subcontractors/suppliers. The failure to meet the goal shall not necessarily be cause for disqualification of the bidder; however, bidders not meeting the goal are required to furnish with their bids written documentation of their Good Faith Efforts to do so.**
- 2) Award of Contract shall be conditioned upon satisfaction of the requirements set forth herein.
- 3) Part III, the Form of Proposal, includes a section entitled "KENTUCKY TRANSPORTATION CABINET-DISADVANTAGED BUSINESS ENTERPRISE PROVISIONS". The applicable information must be completed and submitted as outlined in that document.
- 4) **Failure to submit this information as requested will be cause for rejection of bid.**

E. DOCUMENTATION REQUIRED

- 1) "KENTUCKY TRANSPORTATION CABINET-DISADVANTAGED BUSINESS ENTERPRISE PROVISIONS", located in Part III provides instruction for contractors who do meet the DBE Goal and for contractors who do not meet the DBE Goal.

23. ADDITIONAL PROVISIONS

A. IRREGULAR PROPOSALS

It is the responsibility of each Bidder before submitting a Bid, to (a) examine the Contract Proposals will be considered irregular and will be rejected if:

- 1) The Proposal is not properly signed and notarized.
- 2) The entire authorized Proposal Form furnished is not submitted, or if the forms are altered, or any part is detached.
- 3) The Bidder fails to provide a properly executed Bid Bond.
- 4) The Bidder adds any provisions reserving the right to accept or reject an award, or to enter into a Contract pursuant to an award.

Proposals may be considered irregular and may be rejected if:

- 1) The submitted Proposal fails to comply with any other requirements of the "Invitation to Bid" or the issued Proposal itself.
- 2) There are unauthorized additions, conditional or alternate bids, or irregularities of any kind which may make the Proposal's meaning incomplete, indefinite, or ambiguous.
- 3) A price per unit cannot be determined from the bid proposal, except in the case of authorized alternate pay items.
- 4) The Proposal does not include a unit price for every bid item, except in the case of authorized alternate pay items.
- 5) It is determined that any of the unit prices are materially unbalanced to the potential detriment of the Department.
- 6) The Unit Prices are not typed or entered in ink.

- B. **Disqualification of Bidders.** The following reasons will be considered sufficient for disqualifying a Bidder and rejecting a Proposal or Proposals:
- 1) More than one Bid Proposal for the same work from an individual, firm, or corporation under the same or different name.
 - 2) Evidence of collusion among Bidders.
- C. **Buy America Stipulation** – The Owner is committed to conforming to 23 CFR 635.410 for promoting the use of American made products and all products utilized on this project are subject to the Buy America Stipulation. Specifically, but not limited to, steel products shall be domestically manufactured. Products will be rejected if they are not American made or manufactured.
- D. **Traffic Control** – As part of the Traffic Control Bid item, the Contractor shall establish a traffic control coordinator and notify the Owner of the traffic control coordinator for this project.
- E. **Standard Specifications** – This project shall follow the Kentucky Standard Specifications for Road and Bridge Construction 2012.

F. **Davis Bacon Act-** In accordance with the Davis Bacon Act, as amended, all laborers and mechanics employed by contractors and sub- contractors on projects funded directly by or assisted in whole or in part by and through the Federal Government pursuant to this Act shall be paid wages at rates not less than those prevailing on projects of a character similar in the locality as determined by the Secretary of Labor in accordance with subchapter IV of chapter 31, of title 40, United States Code. With respect to the labor standards specified in this section, the Secretary of Labor shall have the authority and functions set forth in Reorganization Plan Numbered 14 of 1950 (64 Stat. 1267; USC App.) and section 3145 of title 40, United States Code, (Appendix)

G. **Civil Rights Act of 1964** – The Owner, in accordance with the provisions of Title VI of the Civil Rights Act of 1964 (78 Stat. 252) and the Regulations of the Federal Department of Transportation (49 CFR, Part 21), issued pursuant to such Act, hereby notifies all bidders that it will affirmatively ensure that the contract entered into pursuant to this advertisement will be awarded to the lowest responsible bidder without discrimination on the ground of race, color, or national origin.

H. **Notice to All Bidders** – To report bid rigging activities call: 1-800-424-9071

The US Department of Transportation (DOT) operates the above toll-free “hotline” Monday through Friday, 8:00 am to 5:00 pm eastern time. Anyone with knowledge of possible bid rigging, bidder collusion, or other fraudulent activities should use the “hotline” to report such activities.

The “hotline” is part of the DOT’s continuing effort to identify and investigate highway construction contract fraud and abuse and is operated under the direction of the DOT Inspector General. All information will be treated confidentially and caller anonymity will be respected.

The Owner and Bidder shall comply with Title VI of the Civil Rights Act of 1964 and all implementing regulations and executive orders, and Section 504 of the Rehabilitation Act of 1973 and the Kentucky Equal Employment Act 1978 and the Americans with Disabilities Act. No person shall be excluded from participation in, be denied the benefits of, or be subject to discrimination in relation to activities carried out under this bid or any contracting resulting from it on the basis of race, color, age, religion, sex, disability, or national origin. This includes provision of language assistance services to individuals of limited English proficiency seeking and/or eligible for services under this bid or resulting Contract.

I. **Provisions Relative to Senate Bill 258 (1994)** – During the performance of the Contract, the contractor agrees to comply with applicable provisions of:

1. KRS 136 Corporation and Utility Tax
2. KRS 139 Sales and Use Taxes
3. KRS 141 Income Taxes
4. KRS 337 Wages and Hours
5. KRS 338 Occupational Safety and Health of Employees
6. KRS 341 Unemployment Compensation
7. KRS 342 Workers Compensation

J. **Employment Requirements (KRS 344)**

**KENTUCKY TRANSPORTATION CABINET
DEPARTMENT OF HIGHWAYS
EMPLOYMENT REQUIREMENTS
RELATING TO
NONDISCRIMINATION OF EMPLOYEES
(APPLICABLE TO FEDERAL-AID SYSTEM CONTRACTS)**

**AN ACT OF THE KENTUCKY GENERAL ASSEMBLY
TO PREVENT DISCRIMINATION IN EMPLOYMENT
KRS CHAPTER 344
EFFECTIVE JUNE 16, 1972**

The contract on this project, in accordance with KRS Chapter 344, provides that during the performance of this contract, the contractor agrees as follows:

1. The contractor shall not fail or refuse to hire, or shall not discharge any individual, or otherwise discriminate against an individual with respect to his compensation, terms, conditions, or privileges of employment, because of such individual's race, color, religion, national origin, sex, disability or age (between forty and seventy); or limit, segregate, or classify his employees in any way which would deprive or tend to deprive an individual of employment opportunities or otherwise adversely affect his status as an employee, because of such individual's race, color, religion, national origin, sex, disability or age (between forty and seventy). The contractor agrees to post in conspicuous places, available to employees and applicants for employment, notices to be provided setting forth the provisions of this nondiscrimination clause.
2. The contractor shall not print or publish or cause to be printed or published a notice or advertisement relating to employment by such an employer or membership in or any classification or referral for employment by the employment agency, indicating any preference, limitation, specification, or discrimination, based on race, color, religion, national origin, sex, disability or age (between forty and seventy), except that such notice or advertisement may indicate a preference, limitation, or

specification based on religion, or national origin when religion, or national origin is a bona fide occupational qualification for employment.

3. If the contractor is in control of apprenticeship or other training or retraining, including on-the-job training programs, he shall not discriminate against an individual because of his race, color, religion, national origin, sex, disability or age (between forty and seventy), in admission to, or employment in any program established to provide apprenticeship or other training.

4. The contractor will send to each labor union or representative of workers with which he has a collective bargaining agreement or other contract or understanding, a notice to be provided advising the said labor union or workers' representative of the contractor's commitments under this section, and shall post copies of the notice in conspicuous places available to employees and applicants for employment. The contractor will take such action with respect to any subcontract or purchase order as the administrating agency may direct as a means of enforcing such provisions, including sanctions for non-compliance.

Executive Branch Code of Ethics

In the 1992 regular legislative session, the General Assembly passed and Governor Brereton Jones signed Senate Bill 63 (codified as KRS 11A), the Executive Branch Code of Ethics, which states, in part:

KRS 11A.040 (6) provides:

No present or former public servant shall, within six (6) months of following termination of his office or employment, accept employment, compensation or other economic benefit from any person or business that contracts or does business with the state in matters in which he was directly involved during his tenure. This provision shall not prohibit an individual from returning to the same business, firm, occupation, or profession in which he was involved prior to taking office or beginning his term of employment, provided that, for a period of six (6) months, he personally refrains from working on any matter in which he was directly involved in state government. This subsection shall not prohibit the performance of ministerial functions, including, but not limited to, filing tax returns, filing applications for permits or licenses, or filing incorporation papers.

KRS 11A.040 (8) states:

A former public servant shall not represent a person in a matter before a state agency in which the former public servant was directly involved, for a period of one (1) year after the latter of:

- a) The date of leaving office or termination of employment; or
- b) The date the term of office expires to which the public servant was elected.

This law is intended to promote public confidence in the integrity of state government and to declare as public policy the idea that state employees should view their work as a public trust and not as a way to obtain private benefits.

If you have worked for the executive branch of state government within the past six months, you may be subject to the law's prohibitions. The law's applicability may be different if you hold elected office or are contemplating representation of another before a state agency.

Also, if you are affiliated with a firm which does business with the state and which employs former state executive-branch employees, you should be aware that the law may apply to them.

In case of doubt, the law permits you to request an advisory opinion from the Executive Branch Ethics Commission, Room 136, Capitol Building, 700 Capitol Avenue, Frankfort, Kentucky 40601; telephone (502)564-7954.

K. Notice of Requirement for Affirmative Action Executive Order 11246

1. The Offeror's or Bidder's attention is called to the "Equal Opportunity Clause" and the "Standard Federal Equal Employment Specifications" set forth herein.
2. The Contractor's compliance with the Executive Order and the regulations in CFR Part 60-4 shall be based on its implementation of the Equal Opportunity Clause, specific affirmative action obligations required by the specifications set forth in 41 CFR 60-4, 3(a), and its efforts to meet the goals. The hours of minority and female employment and training must be substantially uniform throughout the length of the contract, and in each trade, and the contractor shall make a good faith effort to employ minorities and women evenly on each of its projects. The transfer of minority or female employees or trainees from Contractor to Contractor or from project to project for the sole purpose of meeting the Contractor's goals shall be a violation of the contract, the Executive Order and the regulations in 41 CFR Part 60-4. Compliance with the goals will be measured against the total work hours performed.
3. The Contractor shall provide written notification to the Director of the Office of Federal Contract Compliance Programs within ten (10) working days of award of any construction subcontract in excess of \$10,000.00 at any tier for construction work under the contract resulting from this solicitation. The notification shall list the name, address and telephone number of the subcontractor; employer identification number of the subcontractor; estimated dollar amount of the subcontract; estimated starting and completion dates of the subcontract; and the geographical area in which the subcontract is to be performed. The notification shall be mailed to:

**Evelyn Teague, Regional Director
Office of Federal Contract Compliance Programs
61 Forsyth Street, SW, Suite 7B75
Atlanta, Georgia 30303-8609**

4. As used in this Notice, and in the contract resulting from this solicitation, the "covered area" is Fayette County.

US Department of Labor Final Rule on Federal Executive Order 11246

Discrimination:

Discrimination (because of race, religion, color, national origin, sex, sexual orientation, gender identity, age, or disability) is prohibited. This section applies only to contracts utilizing federal funds, in whole or in part. During the performance of this contract, the contractor agrees as follows:

1. The contractor will not discriminate against any employee or applicant for employment because of race, religion, color, national origin, sex, sexual orientation, gender identity, or age. The contractor further agrees to comply with the provisions of the Americans with Disabilities Act (ADA), Public Law 101-336, and applicable federal regulations relating thereto prohibiting discrimination against otherwise qualified disabled individuals under any program or activity. The contractor agrees to provide, upon request, needed reasonable accommodations. The contractor will take affirmative action to ensure that applicants are employed and that employees are treated during employment without regard to their race, religion, color, national origin, sex, sexual orientation, gender identity, age or disability. Such action shall include, but not be limited to the following; employment, upgrading, demotion or transfer; recruitment or recruitment advertising; layoff or termination; rates of pay or other forms of compensations; and selection for training, including apprenticeship. The contractor agrees to post in conspicuous places, available to employees and applicants for employment, notices setting forth the provisions of this non-discrimination clause.
2. The contractor will, in all solicitations or advertisements for employees placed by or on behalf of the contractor; state that all qualified applicants will receive consideration for employment without regard to race, religion, color, national origin, sex, sexual orientation, gender identity, age or disability.
3. The contractor will send to each labor union or representative of workers with which he has a collective bargaining agreement or other contract or understanding, a notice advising the said labor union or workers' representative of the contractor's commitments under this section, and shall post copies of the notice in conspicuous places available to employees and applicants for employment. The contractor will take such action with respect to any subcontract or purchase order as the administering agency may direct as a means of enforcing such provisions, including sanctions for noncompliance.
4. The contractor will comply with all provisions of Executive Order No. 11246 of September 24, 1965 as amended, and of the rules, regulations and relevant orders of the Secretary of Labor.

5. The contractor will furnish all information and reports required by Executive Order No. 11246 of September 24, 1965, as amended, and by the rules, regulations and orders of the Secretary of Labor, or pursuant thereto, and will permit access to his books, records and accounts by the administering agency and the Secretary of Labor for purposes of investigation to ascertain compliance with such rules, regulations and orders.
6. In the event of the contractor's noncompliance with the nondiscrimination clauses of this contract or with any of the said rules, regulations or orders, this contract may be cancelled, terminated or suspended in whole or in part and the contractor may be declared ineligible for further government contracts or federally-assisted construction contracts in accordance with procedures authorized in Executive Order No. 11246 of September 24, 1965, as amended, and such other sanctions may be imposed and remedies invoked as provided in or as otherwise provided by law.
7. The contractor will include the provisions of paragraphs (1) through (7) of section 202 of Executive Order 11246 in every subcontract or purchase order unless exempted by rules, regulations or orders of the Secretary of Labor, issued pursuant to section 204 of Executive Order No. 11246 of September 24, 1965, as amended, so that such provisions will be binding upon each subcontractor or vendor. The contractor will take such action with respect to any subcontract or purchase order as the administering agency may direct as a means of enforcing such provisions including sanctions for noncompliance; provided, however, that in the event a contractor becomes involved in, or is threatened with, litigation with a subcontractor or vendor as a result of such direction by the agency, the contractor may request the United States to enter into such litigation to protect the interests of the United States.

L. **Standard Title VI/Non-Discrimination Assurances**

During the performance of this contract, the contractor, for itself, its assignees, and successors in interest (hereinafter referred to as the "contractor") agrees as follows:

1. **Compliance with Regulations:** The contractor (hereinafter includes consultants) will comply with the Acts and the Regulations relative to Non-discrimination in Federally-assisted programs of the U.S. Department of Transportation, **Federal Highway Administration**, as they may be amended from time to time, which are herein incorporated by reference and made a part of this contract.
2. **Non-discrimination:** The contractor, with regard to the work performed by it during the contract, will not discriminate on the grounds of race, color, or national origin in the selection and retention of subcontractors, including procurements of materials and leases of equipment. The contractor will not participate directly or indirectly in the discrimination prohibited by the Acts and the Regulations, including

employment practices when the contract covers any activity, project, or program set forth in Appendix B of 49 CFR Part 21.

3. **Solicitations for Subcontracts, Including Procurements of Materials and Equipment:** In all solicitations, either by competitive bidding, or negotiation made by the contractor for work to be performed under a subcontract, including procurements of materials, or leases of equipment, each potential subcontractor or supplier will be notified by the contractor of the contractor's obligations under this contract and the Acts and the Regulations relative to Non-discrimination on the grounds of race, color, or national origin.

4. **Information and Reports:** The contractor will provide all information and reports required by the Acts, the Regulations, and directives issued pursuant thereto and will permit access to its books, records, accounts, other sources of information, and its facilities as may be determined by the Recipient or the **Federal Highway Administration** to be pertinent to ascertain compliance with such Acts, Regulations, and instructions. Where any information required of a contractor is in the exclusive possession of another who fails or refuses to furnish the information, the contractor will so certify to the Recipient or the **Federal Highway Administration**, as appropriate, and will set forth what efforts it has made to obtain the information.

5. **Sanctions for Noncompliance:** In the event of a contractor's noncompliance with the Non-discrimination provisions of this contract, the Recipient will impose such contract sanctions as it or the **Federal Highway Administration** may determine to be appropriate, including, but not limited to:

- a. withholding payments to the contractor under the contract until the contractor complies; and/or
- b. cancelling, terminating, or suspending a contract, in whole or in part.

6. **Incorporation of Provisions:** The contractor will include the provisions of paragraphs one through six in every subcontract, including procurements of materials and leases of equipment, unless exempt by the Acts, the Regulations and directives issued pursuant thereto. The contractor will take action with respect to any subcontract or procurement as the Recipient or the **Federal Highway Administration** may direct as a means of enforcing such provisions including sanctions for noncompliance. Provided, that if the contractor becomes involved in, or is threatened with litigation by a subcontractor, or supplier because of such direction, the contractor may request the Recipient to enter into any litigation to protect the interests of the Recipient. In addition, the contractor may request the United States to enter into the litigation to protect the interests of the United States.

Standard Title VI/Non-Discrimination Statutes and Authorities

During the performance of this contract, the contractor, for itself, its assignees, and successors in interest (hereinafter referred to as the “contractor”) agrees to comply with the following non-discrimination statutes and authorities; including but not limited to:

- Title VI of the Civil Rights Act of 1964 (42 U.S.C. § 2000d *et seq.*, 78 stat. 252), (prohibits discrimination on the basis of race, color, national origin); and 49 CFR Part 21;
- The Uniform Relocation Assistance and Real Property Acquisition Policies Act of 1970, (42 U.S.C. § 4601), (prohibits unfair treatment of persons displaced or whose property has been acquired because of Federal or Federal-aid programs and projects);
- Federal-Aid Highway Act of 1973, (23 U.S.C. § 324 *et seq.*), (prohibits discrimination on the basis of sex);
- Section 504 of the Rehabilitation Act of 1973, (29 U.S.C. § 794 *et seq.*), as amended, (prohibits discrimination on the basis of disability); and 49 CFR Part 27;
- The Age Discrimination Act of 1975, as amended, (42 U.S.C. § 6101 *et seq.*), (prohibits discrimination on the basis of age);
- Airport and Airway Improvement Act of 1982, (49 USC § 471, Section 47123), as amended, (prohibits discrimination based on race, creed, color, national origin, or sex);
- The Civil Rights Restoration Act of 1987, (PL 100-209), (Broadened the scope, coverage and applicability of Title VI of the Civil Rights Act of 1964, The Age Discrimination Act of 1975 and Section 504 of the Rehabilitation Act of 1973, by expanding the definition of the terms “programs or activities” to include all of the programs or activities of the Federal-aid recipients, sub-recipients and contractors, whether such programs or activities are Federally funded or not);
- Titles II and III of the Americans with Disabilities Act, which prohibit discrimination on the basis of disability in the operation of public entities, public and private transportation systems, places of public accommodation, and certain testing entities (42 U.S.C. §§ 12131 -- 12189) as implemented by Department of Transportation regulations at 49 C.F.R. parts 37 and 38;
- The Federal Aviation Administration’s Non-discrimination statute (49 U.S.C. § 47123) (prohibits discrimination on the basis of race, color, national origin, and sex);
- Executive Order 12898, Federal Actions to Address Environmental Justice in Minority Populations and Low-Income Populations, which ensures non-discrimination against minority populations by discouraging programs, policies, and activities with disproportionately high and adverse human health or environmental effects on minority and low-income populations;
- Executive Order 13166, Improving Access to Services for Persons with Limited English Proficiency, and resulting agency guidance, national origin discrimination includes discrimination because of limited English proficiency (LEP). To ensure compliance with Title VI, you must take reasonable steps to ensure that LEP persons have meaningful access to your programs (70 Fed. Reg. at 74087 to 74100);

- Title IX of the Education Amendments of 1972, as amended, which prohibits you from discriminating because of sex in education programs or activities (20 U.S.C. 1681 et seq).

24. REQUIRED SUBMITTALS DOCUMENT CHECKLIST

The following must be submitted with your bid at minimum or your bid may be considered non-responsive and rejected:

- Part III – Form of Proposal
 - Form of Proposal
 - Legal Status of Bidder
 - Required Affidavit for Bidders, Offerors and Contractors (signed & notarized)
 - Bid Schedule
 - Statement of Bidder's Qualifications
 - Kentucky Transportation Cabinet Certificate of Eligibility (it is acceptable to obscure the aggregate bid amount)
 - List of Proposed Subcontractors
 - List of Materials/Equipment/Suppliers
 - DBE Sub-Contractor Bidders List
 - Certification for Federal-Aid Contract
 - Certification of Performance
 - Certification of Organization(s)
 - Certification of Bid Proposal/DBE (percentage must be included)
 - Kentucky Transportation Cabinet – Disadvantaged Business Provisions
 - Non-Collusion Certification
 - Statement of Experience
 - EEO Agreement
 - EEO Affirmative Action Policy
 - Workforce Analysis
 - Evidence of Insurability Form or Certificate of Insurance
 - Debarred Firms
 - Debarment certification
 - Provisions Relative to Senate Bill 258 (1994)
 - Executive Branch Code of Ethics
- Also Provided by Bidder at Bid Opening
 - Bid Bond
 - Bidder KYTC Prequalification Document(s)
 - All Subcontractor Prequalification Document(s)
 - DBE Subcontractor KYTC DBE Document(s)

25. LFUCG NON-APPROPRIATION CLAUSE

Contractor acknowledges that the LFUCG is a governmental entity, and the contract validity is based upon the availability of public funding under the authority of its statutory mandate.

In the event that public funds are unavailable and not appropriated for the performance of the LFUCG's obligations under this contract, then this contract shall automatically expire without penalty to the LFUCG thirty (30) days after written notice to Contractor of the unavailability and non-appropriation of public funds. It is expressly agreed that the LFUCG shall not activate this non-appropriation provision for its convenience or to circumvent the requirements of this contract, but only as an emergency fiscal measure during a substantial fiscal crisis, which affects generally its governmental operations.

In the event of a change in the LFUCG's statutory authority, mandate and mandated functions, by state and federal legislative or regulatory action, which adversely affects the LFUCG's authority to continue its obligations under this contract, then this contract shall automatically terminate without penalty to the LFUCG upon written notice to Contractor of such limitation or change in the LFUCG's legal authority.

END OF SECTION



PART III
FORM OF PROPOSAL

INDEX

1. FORM OF PROPOSAL
2. LEGAL STATUS OF BIDDER
3. BIDDERS AFFIDAVIT
4. BID SCHEDULE – SCHEDULE OF VALUES
5. STATEMENT OF BIDDER'S QUALIFICATIONS
6. LIST OF PROPOSED SUBCONTRACTORS
7. LIST OF MATERIALS/SUPPLIERS
8. DBE SUB-CONTRACTOR BIDDERS LIST
9. CERTIFICATION FOR FEDERAL-AID CONTRACTS
10. CERTIFICATION OF PERFORMANCE
11. CERTIFICATION OF ORGANIZATION(S)
12. CERTIFICATION OF BID PROPOSAL / DBE
13. KENTUCKY TRANSPORTATION CABINET-DISADVANTAGED BUSINESS
ENTERPRISE PROVISIONS
14. NON-COLLUSION CERTIFICATION
15. STATEMENT OF EXPERIENCE
16. EQUAL OPPORTUNITY AGREEMENT
17. EQUAL EMPLOYMENT OPPORTUNITY AFFIRMATIVE
ACTION POLICY
18. WORKFORCE ANALYSIS FORM
19. EVIDENCE OF INSURABILITY
20. DEBARRED FIRMS

21. DEBARMENT CERTIFICATION
22. PROVISIONS RELATIVE TO SENATE BILL 258 (1994)
23. EXECUTIVE BRANCH CODE OF ETHICS
24. EXAMPLE KENTUCKY CERTIFICATE OF ELIGIBILITY

PART III

Invitation to Bid No. 12-2018

**Man O' War Boulevard Public Improvement Project Richmond Road
Intersection**

1. FORM OF PROPOSAL

Place: Lexington, Kentucky

Date: _____

The following Form of Proposal shall be followed exactly in submitting a proposal for this Work.

This Proposal Submitted by _____

(Name and Address of Bidding Contractor)

(Hereinafter called "Bidder"), organized and existing under the laws of the State of _____, doing business as _____
_____ "a corporation," "a partnership", or an "individual" as applicable.

To: Lexington-Fayette Urban County Government
(Hereinafter called "OWNER")
Office of the Director of Purchasing
200 East Main Street, 3rd Floor
Lexington, KY 40507

Gentlemen:

The Bidder, in compliance with your Invitation for Bids for **Man O' War Boulevard Public Improvement Project Richmond Road Intersection** having examined the Plans and Specifications with related documents, having examined the site for proposed Work, and being familiar with all of the conditions surrounding the construction of the proposed Project, including the availability of materials and labor, hereby proposes to furnish all labor, materials, and supplies, and to construct the Project in accordance with the Contract Documents, within the time set forth therein, and at the lump sum and/or unit prices stated hereinafter. These prices are to cover all expenses incurred in performing the Work required under the Contract Documents, of which this proposal is a part.

The Bidder hereby acknowledges receipt of the following addenda:

Addendum No. ____ Date _____

Addendum No. ____ Date _____

Addendum No. ____ Date _____

Addendum No. ____ Date _____

Addendum No. ____ Date _____

Addendum No. ____ Date _____

Addendum No. ____ Date _____

Addendum No. ____ Date _____

Insert above the number and the date of any Addendum issued and received. If none has been issued and received, the word "NONE" should be inserted.

2. **LEGAL STATUS OF BIDDER**

Bidder _____

Date _____

* 1. A corporation duly organized and doing business under the laws of the State of _____, for whom _____, bearing the official title of _____, whose signature is affixed to this Bid/Proposal, is duly authorized to execute contracts.

* 2. A Partnership, all of the members of which, with addresses are: (Designate general partners as such)

* 3. An individual, whose signature is affixed to this Bid/Proposal (please print name)

*(The Bidder shall fill out the appropriate form and strike out the other two.)

3. REQUIRED AFFIDAVIT FOR BIDDERS, OFFERORS AND CONTRACTORS FOR BIDS AND CONTRACTS IN GENERAL:

I. Each bidder or offeror swears and affirms under penalty of perjury, that:

- a. In accordance with KRS 45A.110 and KRS 45A.115, neither the bidder or offeror as defined in KRS 45A.070(6), nor the entity which he/she represents, has knowingly violated any provisions of the campaign finance laws of the Commonwealth of Kentucky; and the award of a contract to the bidder or offeror or the entity which he/she represents will not violate any provisions of the campaign finance laws of the Commonwealth.
- b. The bidder or offeror swears and affirms under penalty of perjury that, to the extent required by Kentucky law, the entity bidding, and all subcontractors therein, are aware of the requirements and penalties outlined in KRS 45A.485; have properly disclosed all information required by this statute; and will continue to comply with such requirements for the duration of any contract awarded.
- c. The bidder or offeror swears and affirms under penalty of perjury that, to the extent required by Kentucky law, the entity bidding, and its affiliates, are duly registered with the Kentucky Department of Revenue to collect and remit the sales and use tax imposed by KRS Chapter 139, and will remain registered for the duration of any contract awarded.
- d. The bidder or offeror swears and affirms under penalty of perjury that the entity bidding is not delinquent on any state taxes or fees owed to the Commonwealth of Kentucky and will remain in good standing for the duration of any contract awarded.

FOR "NON-BID" CONTRACTS (I.E. SOLE-SOURCE; NOT-PRACTICAL OR FEASIBLE TO BID; OR EMERGENCY CONTRACTS, ETC):

II. Each contractor further swears and affirms under penalty of perjury, that:

- a. In accordance with KRS 121.056, and if this is a non-bid contract, neither the contractor, nor any member of his/her immediate family having an interest of 10% or more in any business entity involved in the performance of any contract awarded, have contributed more than the amount specified in KRS 121.150 to the campaign of the gubernatorial slate elected in the election last preceding the date of contract award.
- b. In accordance with KRS 121.330(1) and (2), and if this is a non-bid contract, neither the contractor, nor officers or employees of the contractor or any entity affiliated with the contractor, nor the spouses of officers or employees of the contractor or any entity affiliated with the contractor, have knowingly contributed more than \$5,000 in aggregate to the campaign of a candidate elected in the election last preceding the date of contract award that has jurisdiction over this contract award.
- c. In accordance with KRS 121.330(3) and (4), and if this is a non-bid contract, to the best of his/her knowledge, neither the contractor, nor any member of his/her immediate family, his/her employer, or his/her employees, or any entity affiliated with any of these entities or individuals, have directly solicited contributions in excess of \$30,000 in the aggregate for the campaign of a candidate elected in the election last preceding the date of contract award that has jurisdiction over this contract. As a duly authorized representative for the bidder, offeror, or contractor, I have fully informed myself regarding the accuracy of all statements made in this affidavit, and acknowledge that the Commonwealth is reasonably relying upon these statements, in making a decision for contract award and any failure to accurately disclose such information may result in contract termination, repayment of funds and other available remedies under law.

BIDDERS AFFIDAVIT

Comes the Affiant, _____, and after being first duly sworn, states under penalty of perjury as follows:

1. His/her name is _____ and he/she is the individual submitting the bid or is the authorized representative of _____, the entity submitting the bid (hereinafter referred to as "Bidder").
2. Bidder will pay all taxes and fees, which are owed to the Lexington-Fayette Urban County Government at the time the bid is submitted, prior to award of the contract and will maintain a "current" status in regard to those taxes and fees during the life of the contract.
3. Bidder will obtain a Lexington-Fayette Urban County Government business license, if applicable, prior to award of the contract.
4. Bidder has authorized the Division of Central Purchasing to verify the above-mentioned information with the Division of Revenue and to disclose to the Urban County Council that taxes and/or fees are delinquent or that a business license has not been obtained.
5. Bidder has not knowingly violated any provision of the campaign finance laws of the Commonwealth of Kentucky within the past five (5) years and the award of a contract to the Bidder will not violate any provision of the campaign finance laws of the Commonwealth.
6. Bidder has not knowingly violated any provision of Chapter 25 of the Lexington-Fayette Urban County Government Code of Ordinances, known as the "Ethics Act."
7. Bidder acknowledges that "knowingly" for purposes of this Affidavit means, with respect to conduct or to circumstances described by a statute or ordinance defining an offense, that a person is aware or should have been aware that his conduct is of that nature or that the circumstance exists.
Further, Affiant sayeth naught.

(Affiant)

STATE OF _____

COUNTY OF _____

The foregoing instrument was subscribed, sworn to and acknowledged before me by

_____ on this the _____ day of _____, 20_____.

My Commission expires: _____

NOTARY PUBLIC, STATE AT LARGE

4. BID SCHEDULE – SCHEDULE OF VALUES

The Bidder agrees to perform all the Work described in the Specifications and shown on the Plans for the following proposed lump sum and/or unit prices, if applicable, which shall include the furnishing of all labor, materials, supplies, equipment and/or vehicle usage, services, all items of cost, overhead, taxes (federal, state, local), and profit for the Contractor and any Subcontractor involved, within the time set forth herein. If unit prices are applicable, Bidder must make the extensions and additions showing the total amount of bid.

Form of proposal must include unit bid prices written in words, unit price written in numbers and total amount bid (unit price x quantity) per line item OR bid may be considered non-responsive. In case of price discrepancy, unit bid price written in words will prevail followed by unit price written in numbers then total amount bid per line item.

If a discrepancy between the unit price and the item total exists, the unit price prevails except:

If the unit price is illegible, omitted, or the same as the item total, item total prevails and the unit price is the quotient of the item total and the quantity.

If the unit price and the item total are illegible or are omitted, the bid may be determined nonresponsive. If a lump sum total price is illegible or is omitted, the bid may be determined nonresponsive.

For a lump sum based bid, the item total is the bid amount the Division uses for bid comparison.

For a unit price based bid, the sum of the item totals is the bid amount the Division uses for bid comparison.

The LFUCG's decision on the bid amount is final.

The contract, if awarded, will be on the basis of materials and equipment specified in the specifications without consideration of possible substitute or "or equal" items.

The estimated quantities of items of unit price work are not guaranteed and are solely for the purpose of comparison of bids and determining an initial Contract price. Determination of the actual quantities and classification of unit price work performed by the Contractor will be made by the Engineer in accordance with the General Conditions.

Payment:

Accepted quantities for Work shall be paid for at their respective Contract "Unit Price" as quoted (which shall be for all Work required under this Section) and paid per "Unit To Bid On" of specified "Description" satisfactorily placed. All labor, materials, equipment, and excavation shall be incidental to the Work.

Item No.	Quantity	Unit To Bid On	Description	Unit Price	Total Amount Bid
1.	1	LS	Mobilization (5%) _____ Dollars _____ Cents Per Lump Sum	\$ _____	\$ _____
2.	1	LS	Maintenance and Control of Traffic _____ Dollars _____ Cents Per Lump Sum	\$ _____	\$ _____
3.	1	LS	Staking _____ Dollars _____ Cents Per Lump Sum	\$ _____	\$ _____
4.	1	LS	Erosion Control _____ Dollars _____ Cents Per Lump Sum	\$ _____	\$ _____
5.	1632	LF	Sawcutting Curb & Gutter and Asphalt Pavement _____ Dollars _____ Cents Per Linear Foot	\$ _____	\$ _____
6.	556	SY	Remove Asphalt Pavement _____ Dollars _____ Cents Per Square Yard	\$ _____	\$ _____
7.	1556	LF	Remove Concrete Curb and Gutter _____ Dollars _____ Cents Per Linear Foot	\$ _____	\$ _____
8.	2	EA	Remove Curb Box Inlet _____ Dollars _____ Cents Per Square Yard	\$ _____	\$ _____
9.	1	EA	Remove Drop Box Inlet _____ Dollars _____ Cents Per Each	\$ _____	\$ _____
10.	16	LF	Remove Pipes Less than 24", Up to 8' deep _____ Dollars _____ Cents Per Linear Foot	\$ _____	\$ _____

Item No.	Quantity	Unit To Bid On	Description	Unit Price	Total Amount Bid
11.	1	EA	Remove Manhole _____ Dollars _____ Cents Per Each	\$ _____	\$ _____
12.	355	SY	Remove and Reconstruct Concrete Sidewalk _____ Dollars _____ Cents Per Square Yard	\$ _____	\$ _____
13.	1	LS	Excavation (Unclassified) Engineers estimate 679 CY _____ Dollars _____ Cents Per Lump Sum	\$ _____	\$ _____
14.	50	TN	No. 2 Stone _____ Dollars _____ Cents Per Ton	\$ _____	\$ _____
15.	150	SY	Geotextile Type III Construction _____ Dollars _____ Cents Per Square Yard	\$ _____	\$ _____
16.	570	TN	Dense Graded Aggregate Base _____ Dollars _____ Cents Per Ton	\$ _____	\$ _____
17.	528	LF	Standard Curb and Gutter (LFUCG Type 2) _____ Dollars _____ Cents Per Linear Foot	\$ _____	\$ _____
18.	2	CY	Class A Concrete (Special Pavement Section) _____ Dollars _____ Cents Per Cubic Yard	\$ _____	\$ _____
19.	528	LF	Edge Key _____ Dollars _____ Cents Per Linear Foot	\$ _____	\$ _____
20.	407	TN	CL3 Asphalt Base 1.00D PG76-22 _____ Dollars _____ Cents Per Ton	\$ _____	\$ _____

Item No.	Quantity	Unit To Bid On	Description	Unit Price	Total Amount Bid	
21.	60	TN	CL3 Asphalt Surface 0.38B PG76-22			
				Dollars	\$ _____	\$ _____
				Cents	_____	_____
			Per Ton			
22.	151	TN	Milling and Texturing			
				Dollars	\$ _____	\$ _____
				Cents	_____	_____
			Per Ton			
23.	370	SY	Sodding			
				Dollars	\$ _____	\$ _____
				Cents	_____	_____
			Per Square Yard			
24.	3	EA	Light Pole Base			
				Dollars	\$ _____	\$ _____
				Cents	_____	_____
			Per Each			
25.	528	LF	Electrical Conduit for Lighting			
				Dollars	\$ _____	\$ _____
				Cents	_____	_____
			Per Linear Foot			
26.	528	LF	Conduit for Fiber-Optic Cable			
				Dollars	\$ _____	\$ _____
				Cents	_____	_____
			Per Linear Foot			
27.	1	EA	Adjust Gas Valve to Grade			
				Dollars	\$ _____	\$ _____
				Cents	_____	_____
			Per Each			
28.	1	EA	Adjust Telecommunication Manhole to Grade			
				Dollars	\$ _____	\$ _____
				Cents	_____	_____
			Per Each			
29.	800	LF	Pave Striping – Thermo – 4 In White			
				Dollars	\$ _____	\$ _____
				Cents	_____	_____
			Per Linear Foot			

Item No.	Quantity	Unit To Bid On	Description	Unit Price	Total Amount Bid	
30.	528	LF	Pave Striping – Thermo – 4 In Yellow	Dollars	\$ _____	\$ _____
				Cents		
			Per Linear Foot			
31.	7	EA	Pave Marking – Thermo Curve Arrow	Dollars	\$ _____	\$ _____
				Cents		
			Per Each			
32.	42	EA	Inlaid Pavement Markers	Dollars	\$ _____	\$ _____
				Cents		
			Per Each			
33.	528	LF	Remove and Replace Fence	Dollars	\$ _____	\$ _____
				Cents		
			Per Linear Foot			
34.	2	EA	Manhole Type A	Dollars	\$ _____	\$ _____
				Cents		
			Per Each			
35.	2	EA	Curb Box Inlet Type C	Dollars	\$ _____	\$ _____
				Cents		
			Per Each			
36.	19	LF	15" RCP Storm Sewer (0-8' No rock)	Dollars	\$ _____	\$ _____
				Cents		
			Per Linear Foot			
37.	1	LS	Demobilization (1.5%)	Dollars	\$ _____	\$ _____
				Cents		
			Per Lump Sum			

TOTAL OF ALL BID PRICES FOR Man O'War Boulevard Public Improvement Projects Richmond Road Intersection Project (Items 1 through 37) in words and figures. In case of discrepancy, the amount shown in words will govern.

_____ (\$_____).

Submitted by:

Firm

Address

City, State & Zip

***Bid must be signed:
(original signature)***

Signature of Authorized Company Representative – Title

Representative/s Name (Typed or Printed)

Area Code – Phone – Extension

Fax #

E-Mail Address

OFFICIAL ADDRESS:

_____ (Seal if Bid is by Corporation)

By signing this form you agree to ALL terms, conditions, and associated forms in this bid package

5. STATEMENT OF BIDDER'S QUALIFICATIONS

The following statement of the Bidder's qualifications is required to be filled in, executed, and submitted with the Proposal:

1. Name of Bidder: _____
2. Permanent Place of Business: _____
3. When Organized: _____
4. Where Incorporated: _____
5. Construction Plant and Equipment Available for this Project:

(Attach Separate Sheet If Necessary)

6. Financial Condition:

If specifically requested by the OWNER, the apparent low Bidder is required to submit its latest three (3) years audited financial statements to the OWNER'S Division of Central Purchasing within seven (7) calendar days following the bid opening.

7. In the event the Contract is awarded to the undersigned, surety bonds will be furnished by:

_____ (Surety)

Signed: _____ (Representative of Surety)

8. The following is a list of similar projects performed by the Bidder: (Attach separate sheet if necessary).

<u>NAME</u>	<u>LOCATION</u>	<u>CONTRACT SUM</u>
_____	_____	_____
_____	_____	_____
_____	_____	_____
_____	_____	_____
_____	_____	_____

9. The Bidder has now under contract and bonded the following projects:

<u>NAME</u>	<u>LOCATION</u>	<u>CONTRACT SUM</u>
_____	_____	_____
_____	_____	_____
_____	_____	_____
_____	_____	_____
_____	_____	_____

10. List Key Bidder Personnel who will work on this Project.

<u>NAME</u>	<u>POSITION DESCRIPTION</u>	<u>NO. OF YEARS WITH BIDDER</u>
_____	_____	_____
_____	_____	_____
_____	_____	_____
_____	_____	_____
_____	_____	_____

11. DBE Participation on current bonded projects under contract:

<u>SUBCONTRACTORS</u> <u>(LIST)</u>	<u>PROJECT</u> <u>(SPECIFIC TYPE)</u>	<u>DBE</u>	<u>% of WORK</u>
_____	_____	_____	_____
_____	_____	_____	_____
_____	_____	_____	_____
_____	_____	_____	_____
_____	_____	_____	_____
_____	_____	_____	_____
_____	_____	_____	_____

(USE ADDITIONAL SHEETS IF NECESSARY)

12. We acknowledge that, if we are the apparent low Bidder, we may be required to submit to the OWNER within 7 calendar days following the Bid Opening, a sworn statement regarding all current work on hand and under contract, and a statement on the OWNER'S form of the experience of our officers, office management and field management personnel. Additionally, if requested by the OWNER, we will within 7 days following the request submit audited financial statements and loss history for insurance claims for the 3 most recent years (or a lesser period stipulated by the OWNER).

Respectfully submitted:

(Name of Contracting Firm)

BY: _____

TITLE: _____

DATE _____, 20__

6. LIST OF PROPOSED SUBCONTRACTORS

The following list of proposed subcontractors is required by the OWNER to be executed, completed and submitted with the BIDDER'S FORM OF PROPOSAL. All subcontractors are subject to approval of the Lexington-Fayette Urban County Government. Failure to submit this list completely filled out may be cause for rejection of bid.

<u>BRANCH OF WORK - LIST EACH MAJOR ITEM</u> Such as: Grading, bituminous paving, concrete, seeding and protection, construction staking, etc.	<u>SUBCONTRACTOR</u>	<u>DBE</u> <u>Yes/No</u>	% of Work
1. _____	Name: _____ Address: _____	_____	_____
2. _____	Name: _____ Address: _____	_____	_____
3. _____	Name: _____ Address: _____	_____	_____
4. _____	Name: _____ Address: _____	_____	_____
5. _____	Name: _____ Address: _____	_____	_____
6. _____	Name: _____ Address: _____	_____	_____
7. _____	Name: _____ Address: _____	_____	_____

(Attach additional sheet(s) if necessary.)

7. LIST OF MATERIALS/ SUPPLIERS

Bidders are hereby advised that this list must be complete and submitted with the Bid.

Listing "as per plans and specifications", will not be considered as sufficient identification. Where more than one "Make or Brand" is listed for any one item, the Owner has the right to select the one to be used.

Item	Brand Name, Manufacturer and/or Supplier
1. Concrete Supplier	<hr/>
2. Asphalt Supplier	<hr/>

8. DBE SUB-CONTRACTOR BIDDERS LIST

The Department of Transportation Federal Regulations requires that the Kentucky Transportation Cabinet provide a bidders list to be maintained in the Office of Personnel Management, Small Business Development Branch (49CFR 26:11) for each federally funded project awarded.

Project No.: STPM 3003-290

List all quotes/bids received on this project.

DBE (Disadvantaged Business Enterprise) Contractors, Consultants, and Suppliers submitting quotes/bids for this project:

- 1.
- 2.
- 3.
- 4.
- 5.
- 6.
- 7.
- 8.

DBE (Disadvantaged Business Enterprise) Contractors, Consultants, and Suppliers contacted who did NOT submit quotes/bids for this project.

- 1.
- 2.
- 3.
- 4.
- 5.

- 6.
- 7.
- 8.

Non-DBE (Disadvantaged Business Enterprise) Contractors, Consultants, and Suppliers submitting quotes/bids for this project:

- 1.
- 2.
- 3.
- 4.
- 5.
- 6.
- 7.
- 8.

If you need additional space, please attach a separate page. If you need assistance regarding this form, please contact Melvin Bynes or Anita Hall at (502)564-3601.

9. **CERTIFICATION FOR FEDERAL-AID CONTRACT**

The prospective participant certifies, by signing and submitting this bid or proposal, to the best of his or her knowledge and belief, that:

1. No Federal appropriated funds have been paid or will be paid, by or on behalf of the undersigned, to any person for influencing or attempting to influence an officer or employee of any Federal agency, a Member of Congress, an officer or employee of Congress, or an employee of a Member of Congress in connection with the awarding of any Federal contract, the making of any Federal grant, the making of any Federal loan, the entering into of any cooperative agreement, and the Improvements Project, continuation, renewal, amendment, or modification of any Federal contract, grant, loan, or cooperative agent.
2. If any funds other than the Federal appropriated funds have been paid or will be paid to any person for influencing or attempting to influence an officer or employee of any Federal agency, a Member of Congress, an officer or employee of congress, or an employee of a Member of Congress in connection with this Federal contract, grant, loan, or cooperative agreement, the undersigned shall complete and submit Standard Form-LLL, "Disclosure Form to Report Lobbying," in accordance with its instructions.

This certification is a material representation of fact which reliance was placed when this transaction was made or entered into. Submission of this certification is a prerequisite for making or entering into this transaction imposed by Section 1352, Title 31, U.S. Code. Any person who fails to file the required certification shall be subject to a civil penalty of not less than \$10,000 and not more than \$100,000 for each such failure.

The prospective participation also agrees by submitting his or her bid proposal that he or she shall require the language of this certification be included in all lower tier subcontracts, which exceed \$100,000 and that all such subrecipients shall certify and disclose accordingly.

(Name of Individual, Co-Partnership, or Corporation submitting bid)

(Name of Officer or Authorized Agent) (Title)

(Signature) (Date)

10. CERTIFICATION OF PERFORMANCE

Certification with regard to the Performance of Previous Contracts or Subcontracts subject to the Equal Opportunity Clause and the filing of Required Reports.

The _____, hereby certifies that he _____, participated in previous contract or subcontract subject to the equal opportunity clause, as required by Executive Orders 10925, 11114, or 11246, and that he, filed with the Joint Reporting committee, the Director of the Office of Federal Contract Compliance, a Federal Government contracting or administering agency, or the Former President's Committee on Equal Employment Opportunity, all reports due under the applicable filing requirements.

(Name of Individual, Co-Partnership, or Corporation submitting bid)

(Name of Officer or Authorized Agent) (Title)

(Signature) (Date)

NOTE: The above certification is required by the Equal Employment Opportunity Regulations of the Secretary of Labor (41 CFR 60-1.7 (b) (1)), and must be submitted by bidders and proposed subcontractors only in connection with the contracts and subcontracts which are subject to the equal opportunity clause. Contracts and subcontracts which are exempt from the equal opportunity clause are set forth in 41 CFR 60-1.5. (Generally only contracts or subcontracts of \$10,000 or under are exempt.)

Currently, Standard Form 100 (EE0-1) is the only report required by the Executive Orders of their implementing regulation.

Proposed prime contractors and subcontractors who have participated in a previous contract or subcontract subject to the Executive Orders and have not filed reports should note that 41 CFR 60-

1.7 (b) (1) prevents the award of contracts and subcontracts unless such contractor submits a report covering the delinquent period or such other period specified by the Federal Highway Administration or by the Director or by the Director, Office of Federal Contract Compliance, U.S. Department of Labor.

11. CERTIFICATION OF ORGANIZATION(S)

COMMONWEALTH OF KENTUCKY

COUNTY: FAYETTE

FEDERAL PROJECT NO: STPM 3003-290

I, _____, _____
(Name of officer or Authorized Agent) (Title)

under penalty of perjury under the laws of the United States, do hereby certify that, except as noted below,

(Name of Individual, Co-Partnership, or Corporation submitting bid)

any person associated therewith in the capacity of (owner, partner, director, officer, principal investigator, project director, manager, auditor, or any position involving the Administration of Federal Funds): is not currently under suspension, debarment, voluntarily exclusion, or determination of ineligibility by any federal agency; has not been suspended, debarred, voluntarily excluded or determined ineligible by any federal agency within the past 3 years; does not have a proposed debarment pending; and has not been indicted, convicted, or had a civil judgment rendered against (it) by a court of competent jurisdiction in any matter involving fraud or official misconduct within the past 3 years.

Please list below any exceptions to the foregoing, to whom it applies, initiating agency and dates of action.

Exceptions:

(Name of Individual, Co-Partnership, or Corporation submitting bid)

(Name of Officer or Authorized Agent) (Title)

(Signature) (Date)

12. CERTIFICATION OF BID PROPOSAL/DBE

We (I) proposed to furnish all labor, equipment and material necessary to construct and/or improve the subject project in accordance with the plans, the Transportation Cabinet's Standard Specifications for Road and Bridge Construction, current edition, special provisions, notes applicable to the project as indicated herein and all addenda issued on this project subsequent to purchase of proposal.

We (I) attach a bid guaranty as provided in the special provisions in an amount not less than 5% of the total bid. We agree to execute a contract in accordance with this proposal within 15 calendar days after the receipt of the notice of award for the project.

We (I) have examined the site of proposed work, project plans, specifications, special provisions, and notes applicable to the project referred to herein. We understand that the quantities shown herein are estimated quantities subject increase or decrease as provided in the specifications.

We (I) acknowledge receipt of all addendum(s) (if applicable) and have made necessary revisions to the bid proposal. We have considered all addendum(s) in calculation of the submitted bid and applied the updated bid items, which are included.

"The bidder certifies that it has secured participation by Disadvantaged Business Enterprises (DBE) in amount of (%) percent of the total value of this contract and that the DBE participation is in compliance with the requirements of 49 CFR 26 and the policies of the Kentucky Transportation Cabinet pertaining to the DBE Program."

(Name of Individual, Co-Partnership, or Corporation submitting bid)

(Name of Officer or Authorized Agent)

(Title)

(Signature)

(Date)

When two or more organizations bid as a joint venture, enter names of each organization and an authorized agent for each organization must sign above.

13. KENTUCKY TRANSPORTATION CABINET – DBE PROVISIONS

KENTUCKY TRANSPORTATION CABINET – DISADVANTAGED BUSINESS ENTERPRISE PROVISIONS

SECOND TIER SUBCONTRACTS

Second Tier subcontracts on federally assisted projects shall be permitted. However, in the case of DBE's, second tier subcontracts will only be permitted where the other subcontractor is also a DBE. All second tier subcontracts shall have the consent of both the Contractor and the Engineer.

DISADVANTAGED BUSINESS ENTERPRISE PROGRAM

It is the policy of the Lexington-Fayette Urban County Government ("LFUCG") that Disadvantaged Business Enterprises ("DBE") shall have the opportunity to participate in the performance of highway construction projects financed in whole or in part by Federal Funds in order to create a level playing field for all businesses who wish to contract with the LFUCG. To that end, the LFUCG will comply with the regulations found in 49 CFR Part 26, and the definitions and requirements contained therein shall be adopted as if set out verbatim herein.

The LFUCG, contractors, subcontractors, and sub-recipients shall not discriminate on the basis of race, color, national origin, or sex in the performance of work performed pursuant to LFUCG contracts. The contractor shall carry out applicable requirements of 49 CFR 26 in the award and administration of federally assisted highway construction projects. The contractor will include this provision in all its subcontracts and supply agreements pertaining to contracts with the LFUCG.

Failure by the contractor to carry out these requirements is a material breach of its contract with the LFUCG, which may result in the termination of the contract or such other remedy as the LFUCG deems necessary.

DBE REQUIREMENT

The Disadvantaged Business Enterprise (DBE) requirement established for this contract, is 7%, and is the percentage of the total value of the contract.

The contractor shall exercise all necessary and reasonable steps to ensure that Disadvantaged Business Enterprises participate in a least the percent of the contract as set forth above as goals for this contract.

OBLIGATION OF CONTRACTORS

If a formal goal has not been designated for the contract, all contractors are expected to meet the MWDBE goal, unless otherwise stated. Contractor shall also consider DBEs for subcontract work as well as for the supply of material and services needed to perform this work.

Contractors are encouraged to use the services of banks owned and controlled by minorities and women.

CERTIFICATION OF CONTRACT GOAL

Contractors shall include the following certification in bids for projects for which a DBE goal has been established. BIDS SUBMITTED WHICH DO NOT INCLUDE CERTIFICATION OF DBE

PARTICIPATION WILL NOT BE ACCEPTED. These bids will not be considered for award by the LFUCG and they will be returned to the bidder.

“The bidder certifies that it has secured participation by Disadvantaged Business Enterprises (“DBE”) in the amount of KYTC _____ percent (_____ %) of the total value of this contract and that the DBE participation is in compliance with the requirements of 49 CFR 26 and the policies of the Lexington-Fayette Urban County Government related to participation and Kentucky Transportation Cabinet pertaining to the DBE Program.”

DBEs utilized in achieving the DBE goal must be certified and pre-qualified for the work items at the time the bid is submitted.

DBE PARTICIPATION PLAN

Lowest responsive bidders must submit the DBE Plan/ Subcontractor Request, form TC 63-35 DBE, within 7 days of the letting. This is necessary before the LFUCG Division of Central Purchasing will review and make a recommendation. The project will not be considered for award prior to submission and approval of the apparent low bidder’s DBE Plan/Subcontractor Request.

The DBE Participation Plan shall include the following:

- 1 Name and address of DBE Subcontractor(s) and/or supplier(s) intended to be used in the proposed project;
- 2 Description of the work each is to perform including the work item, unit, quantity, unit price and total amount of the work to be performed by the individual DBE and the project bid number.
- 3 The dollar value of each proposed DBE subcontract and the percentage of total project contract value this represents. DBE participation may be counted as follows:
 - a) If DBE suppliers and manufactures assume actual and contractual responsibility, the dollar value of materials to be furnished will be counted toward the goal as follows:

The entire expenditure paid to a DBE manufacturer;
60 percent of expenditures to DBE suppliers that are not manufacturers provided the supplier is a regular dealer in the product involved. A regular dealer must be engaged in, as its principal business and in its own name, the sale of products to the public, maintain an inventory and own and operate distribution equipment; and

The amount of fees or commissions charged by the DBE firms for a bona fide service, such as professional, technical, consultant, or managerial services and assistance in the procurement of essential personnel, facilities, equipment, materials, supplies, delivery of materials and supplies or for furnishing bonds, or insurance, providing such fees or commissions are determined to be reasonable and customary.
 - b) The dollar value of services provided by DBEs such as quality control testing, equipment repair and maintenance, engineering, staking, etc;
 - c) The dollar value of joint ventures. DBE credit for joint ventures will be limited to the dollar amount of the work actually performed by the DBE in the joint venture;
- 4 Written and signed documentation of the bidder’s commitment to use a DBE contractor whose participation is being utilized to meet the DBE goal; and
- 5 Written and signed confirmation from the DBE that it is participating in the contract as provided in the prime contractor’s commitment.

UPON AWARD AND BEFORE A WORK ORDER WILL BE ISSUED

Contractors must submit the signed subcontract between the contractor and the DBE contractor, the DBE's certificate of insurance, and the Required Affidavit of Bidders, Offerors, and Contractors from the DBE to the LFUCG Division of Central Purchasing. The Required Affidavit of Bidders, Offerors and Contractors is included with these bid documents and should be returned with your bid. If the DBE is a supplier of materials for the project, a signed purchase order and a Required Affidavit for Bidders, Offerors, and Contractors must be submitted to the LFUCG Division of Central Purchasing.

Changes to DBE Participation Plans or DBE substitutions must be approved by the LFUCG Division of Central Purchasing. The LFUCG may consider extenuating circumstances including, but not limited to, changes in the nature or scope of the project, the inability or unwillingness of a DBE to perform the work in accordance with the bid, and/or other circumstances beyond the control of the prime contractor.

CONSIDERATION OF GOOD FAITH EFFORTS REQUESTS

If the DBE participation submitted in the bid by the apparent lowest responsive bidder does not meet or exceed the DBE contract goal, the apparent lowest responsive bidder must submit a Good Faith Effort documentation to satisfy the LFUCG that sufficient good faith efforts were made to meet the contract goals prior to submission of the bid. Efforts to increase the goal after bid submission will not be considered in justifying the good faith effort, unless the contractor can show that the proposed DBE was solicited prior to the bid date. DBEs utilized in achieving the DBE goal must be certified and pre-qualified for the work items at the time the bid is submitted. One complete set of this information must be received in the office of the LFUCG Division of Central Purchasing no later than 12:00 noon of the tenth calendar day after receipt of notification that they are the apparent low bidder.

Where the information submitted includes repetitious solicitation letters it will be acceptable to submit a sample representative letter along with a distribution list of the firms solicited. Documentation of DBE quotations shall be a part of the good faith effort submittal as necessary to demonstrate compliance with the factors listed below which the LFUCG considers in judging good faith efforts. This documentation may include written subcontractors' quotations, telephone log notations of verbal quotations, or other types of quotation documentation.

The Good Faith Efforts documentation shall include, but may not be limited to information showing evidence of the following:

- 1 Whether the bidder attended any pre-bid meetings that were scheduled by LFUCG to inform DBEs of subcontracting opportunities;
- 2 Whether the bidder provided solicitations through all reasonable and available means;
- 3 Whether the bidder provided written notice to all DBEs listed in the DBE directory at the time of the letting that are pre-qualified in the areas of work that the bidder will be subcontracting;
- 4 Whether the bidder followed up initial solicitations of interest by contacting DBEs to determine with certainty whether they were interested. If a reasonable amount of DBEs within the targeted districts do not provide an intent to quote or no DBEs are pre-qualified in the subcontracted areas, the bidder must notify the Minority Business Enterprise Liaison in the Division of Central Purchasing to give notification of the bidder's inability to get DBE quotes;

5 Whether the bidder selected portions of the work to be performed by DBEs in order to increase the likelihood of meeting the contract goals. This includes, where appropriate, breaking out contract work items into economically feasible units to facilitate DBE participation, even when the prime contractor might otherwise perform these work items with its own forces;

6 Whether the bidder provided interested DBEs with adequate and timely information about the plans, specifications, and requirements of the contract;

7 Whether the bidder negotiated in good faith with interested DBEs not rejecting them as unqualified without sound reasons based on a thorough investigation of their capabilities. Any rejection should be so noted in writing with a description as to why an agreement could not be reached;

8 Whether quotations were received from interested DBE firms but were rejected as unacceptable without sound reasons why the quotations were considered unacceptable. The fact that the DBE firm's quotation for the work is not the lowest quotation received will not in itself be considered as a sound reason for rejecting the quotation as unacceptable. The fact that the bidder has the ability and/or desire to perform the contract work with its own forces will not be considered a sound reason for rejecting a DBE quote. Nothing in this provision shall be construed to require the bidder to accept unreasonable quotes in order to satisfy DBE goals;

9 Whether the bidder specifically negotiated with subcontractors to assume part of the responsibility to meet the contract DBE goal when the work to be subcontracted includes potential DBE participation;

10 Whether the bidder made any efforts and/or offered assistance to interested DBEs in obtaining the necessary equipment, supplies, materials, insurance and/or bonding to satisfy the work requirements of the bid proposal; and

11 Any other evidence that the bidder submits which may show that the bidder has made reasonable good faith efforts to include DBE participation.

FAILURE TO MEET GOOD FAITH REQUIREMENT

Where the apparent lowest responsive bidder fails to submit sufficient participation by DBE firms to meet the contract goal and upon a determination by the LFUCG Division of Central Purchasing based upon the information submitted that the apparent lowest responsive bidder failed to make sufficient reasonable efforts to meet the contract goal, the bidder will be offered the opportunity to meet in person with representatives from the Division of Central Purchasing. The bidder will be notified of the Division of Central Purchasing's decision within 24 hours of its decision. The bidder will have 24 hours to request reconsideration of Central Purchasing's decision. The reconsideration meeting will be held within two days of the receipt of a request by the bidder for reconsideration.

The request for reconsideration will be heard by Central Purchasing. The bidder will have the opportunity to present written documentation or argument concerning the issue of whether it met the goal or made an adequate good faith effort. The bidder will receive a written decision on the reconsideration explaining the basis for the finding that the bidder did or did not meet the goal or made adequate Good Faith efforts to do so.

The result of the reconsideration process is not administratively appealable to the LFUCG Division of Central Purchasing.

The LFUCG Division of Central Purchasing reserves the right to award the contract to the next lowest responsive bidder or to rebid the contract in the event that the contract is not awarded to the low bidder as the result of a failure to meet the good faith requirement.

SANCTIONS FOR FAILURE TO MEET DBE REQUIREMENTS OF THE PROJECT

Failure by the prime contractor to fulfill the DBE requirements of a project under contract or to demonstrate good faith efforts to meet the goal constitutes a breach of contract. When this occurs, the Cabinet will hold the prime contractor accountable, as would be the case with all other contract provisions. Therefore, the contractor's failure to carry out the DBE contract requirements shall constitute a breach of contract and as such the Cabinet reserves the right to exercise all administrative remedies at its disposal including, but not limited to the following:

- Disallow credit toward the DBE goal;
- Withholding progress payments;
- Withholding payment to the prime in an amount equal to the unmet portion of the contract goal; and/or
- Termination of the contract.

PROMPT PAYMENT

The prime contractor will be required to pay the DBE within seven (7) working days after he or she has received payment from the LFUCG Division of Central Purchasing for work performed or materials furnished

CONTRACTOR REPORTING All Contractors must report on their progress in meeting the DBE requirement on any construction contracts. These records may include, but shall not be limited to payroll, lease agreements, cancelled payroll checks, executed subcontracting agreements, etc. Prime contractors will be required to submit certified reports on monies paid to each DBE subcontractor or supplier utilized to meet a DBE goal.

Payment information that needs to be reported includes date the payment is sent to the DBE, check number, Contract ID, amount of payment and the check date. Before Final Payment is made on this contract, the Prime Contractor will certify that all payments were made to the DBE subcontractor and/or DBE suppliers and show the documented proof.

The Prime Contractor should supply the payment information at the time the DBE is compensated for their work. Form to use is located at:

<http://transportation.ky.gov/Construction/Pages/Subcontracts.aspx>

Photocopied payments and completed form to be submitted to:

Office of Civil Rights and Small
Business Development 6th Floor
West 200 Mero Street Frankfort, KY 40622

DEFAULT OR DECERTIFICATION OF THE DBE

If the DBE subcontractor or supplier is decertified or defaults in the performance of its work, and the overall goal cannot be credited for the uncompleted work, the prime contractor may utilize a substitute DBE or elect to fulfill the DBE goal with another DBE on a different work item. If after exerting good faith effort in accordance with the LFUCG Division of Central Purchasing policies

and procedures, the prime contractor is unable to replace the DBE, then the unmet portion of the goal may be waived at the discretion of the LFUCG Division of Central Purchasing.

14. **AUTHENTICATION OF BID AND STATEMENT OF NON-COLLUSION, NON-CONFLICT OF INTEREST**

I hereby swear (or affirm) under the penalty for false swearing:

1. That I am the Bidder (if the Bidder is an individual), a partner of the Bidder (if the Bidder is a partnership), or an officer or employee of the bidding corporation having authority to sign on its behalf (if the Bidder is a corporation);
2. That the attached bid has been arrived at by the Bidder independently, and has been submitted without collusion with, and without any agreement, understanding or planned common course of action, with any other contractor, vendor of materials, supplies, equipment or services described in the Invitation to Bid, designed to limit independent bidding or competition;
3. That the contents of the bid or bids have not been communicated by the Bidder or its employees or agents to any person not an employee or agent of the Bidder or its surety on any bond furnished, with the bid or bids, and will not be communicated to any such person, prior to the official opening of the bid or bids;
4. That the Bidder is legally entitled to enter into the contracts with the Lexington-Fayette Urban County Government, and is not in violation of any prohibited conflict of interest;
5. (Applicable to corporation only) That as a foreign corporation, we are registered with the Secretary of State, Commonwealth of Kentucky, and authorized to do business in the State _____ or, that as a domestic corporation, we are in good standing with the Secretary of State, Commonwealth of Kentucky _____. Check the statement applicable.
6. This offer is for 60 calendar days from the date this bid is opened. In submitting the above, it is expressly agreed that, upon proper acceptance by the Lexington-Fayette Urban County Government of any or all items bid above, a contract shall thereby be created with respect to the items accepted.
7. That I have fully informed myself regarding the accuracy of the statements made in this statement.
8. That I certify that Subcontractors have not and will not be awarded to any firm(s) that have been debarred from noncompliance with the Federal Labor Standards, Title VI of the Civil Rights Act of 1964 As Amended, Executive Order 11246 As Amended or any other Federal Law.

COMMONWEALTH OF KENTUCKY

COUNTY: FAYETTE

FEDERAL PROJECT NO: STPM 3003-290

I, _____, _____,
(Name of officer or Authorized Agent) (Title)

under penalty of perjury under the laws of the United States, do hereby certify that

(Name of Individual, Co-Partnership, or Corporation submitting bid)

Its agent, officers or employees have not directly or indirectly entered into any agreement, participated in any collusion, or otherwise taken action in restraint of free competitive bidding in connection with this proposal.

15. STATEMENT OF EXPERIENCE

NAME OF INDIVIDUAL: _____

POSITION/TITLE: _____

STATEMENT OF EXPERIENCE: _____

NAME OF INDIVIDUAL: _____

POSITION/TITLE: _____

STATEMENT OF EXPERIENCE: _____

NAME OF INDIVIDUAL: _____

POSITION/TITLE: _____

STATEMENT OF EXPERIENCE: _____

NAME OF INDIVIDUAL: _____

POSITION/TITLE: _____

STATEMENT OF EXPERIENCE: _____

NAME OF INDIVIDUAL: _____

POSITION/TITLE: _____

STATEMENT OF EXPERIENCE: _____

NAME OF INDIVIDUAL: _____

POSITION/TITLE: _____

STATEMENT OF EXPERIENCE: _____

* Include all officers, office management's, Affirmative Action officials, and field management personnel. (Attach separate sheets if necessary.)

16. EQUAL OPPORTUNITY AGREEMENT

The Law

- * Title VII of the Civil Rights Act of 1964 (amended 1972) states that it is unlawful for an employer to discriminate in employment because of race, color, religion, sex, age (40-70 years) or national origin.
- * Executive Order No. 11246 on Nondiscrimination under Federal contract prohibits employment discrimination by contractor and subcontractor doing business with the Federal Government or recipients of Federal funds. This order was later amended by Executive Order No. 11375 to prohibit discrimination on the basis of sex.
- * Section 503 of the Rehabilitation Act of 1973 States:
The Contractor will not discriminate against any employee or applicant for employment because of physical or mental handicap.
- * Section 2012 of the Vietnam Era Veterans Readjustment Act of 1973 requires Affirmative Action on behalf of disabled veterans and veterans of the Vietnam Era by contractors having Federal Contracts.
- * Section 206 (A) of Executive Order 12086, Consolidation of Contract Compliance Functions for Equal Employment Opportunity, states:
The Secretary of Labor may investigate the employment practices of any Government contractor or sub-contractor to determine whether or not the contractual provisions specified in Section 202 of this order have been violated.

The Lexington-Fayette Urban County Government practices Equal Opportunity in recruiting, hiring and promoting. It is the Government's intent to affirmatively provide employment opportunities for those individuals who have previously not been allowed to enter into the mainstream of society. Because of its importance to the local Government, this policy carries the full endorsement of the Mayor, Commissioners, Directors, and all supervisory personnel. In following this commitment to Equal Employment Opportunity and because the Government is the benefactor of the Federal funds, it is both against the Urban County Government policy and illegal for the Government to let contracts to companies which knowingly or unknowingly practice discrimination in their employment practices. Violation of the above mentioned ordinances may cause a contract to be canceled and the contractor may be declared ineligible for future consideration.

Please sign this statement in the appropriate space acknowledging that you have read and understand the provisions contained herein. Return this document as part of your application packet.

Bidders

I/We agree to comply with the Civil Rights Laws listed above that govern employment rights of minorities, women, Vietnam veterans, handicapped, and aged persons.

Signature

Name of Business

The Entity (regardless of whether construction contractor, non-construction contractor or supplier) agrees to provide equal opportunity in employment for all qualified persons, to prohibit discrimination in employment because of race, color, creed, national origin, sex or age, and to promote equal employment through a positive, continuing program from itself and each of its sub-contracting agents. This program of equal employment opportunity shall apply to every aspect of its employment policies and practices.

The Kentucky equal Employment Opportunity Act of 1978 (KRS 45.560-45.640) requires that any count, city, town, school district, water district, hospital district, or other political subdivision of the state shall include in directly or indirectly publicly funded contracts for supplies, materials, services, or equipment hereinafter entered into the following provisions:

During the performance of this contract, the contractor agrees as follows:

- (1) *The contractor will not discriminate against any employee or applicant for employment because of race, color, religion, sex, age or national origin;*
- (2) *The contractor will state in all solicitations or advertisements for employees placed by or on behalf of the contractors that all qualified applicants will receive consideration for employment without regard to race, color, religion, sex, age or national origin;*
- (3) *The contract will post notices in conspicuous places, available to employees and applicants for employment, setting forth the provisions of the non-discrimination clauses required by this section; and*
- (4) *The contractor will send a notice to each labor union or representative of workers with which he has a collective bargaining agreement or other contract or understanding advising the labor union or workers' representative of the contractor's commitments under the nondiscrimination clauses.*

The Act further provides:

KRS 45.610. Hiring minorities – Information required

- (1) *For the length of the contract, each contractor shall hire minorities from other sources within the drawing area, should the union with which he has collective bargaining agreements be unwilling to supply sufficient minorities to satisfy the agreed upon goals and timetable.*

- (2) *Each contractor shall, for the length of the contract, furnish such information as required by KRS 45.560 to KRS 45.640 and by such rules, regulations and orders issued pursuant thereto and will permit access to all books and records pertaining to his employment practices and work sites by the contracting agency and the department for purposes of investigation to ascertain compliance with KRS 45.560 to 45.640 and such rules, regulations and orders issued pursuant thereto.*

KRS 45.620. Action against contractor – Hiring of minority contractor or subcontractor

- (1) *If any contractor is found by the department to have engaged in an unlawful practice under this chapter during the course of performing under a contract or subcontract covered under KRS 45.560 to 45.640, the department shall so certify to the contracting agency and such certification shall be binding upon the contracting agency unless it is reversed in the course of judicial review.*
- (2) *If the contractor is found to have committed an unlawful practice under KRS 45.560 to 45.640, the contracting agency may cancel or terminate the contract, conditioned upon a program for future compliance approved by the contracting agency and the department. The contracting agency may declare such a contractor ineligible to bid on further contracts with that agency until such time as the contractor complies in full with the requirements of KRS 45.560 – 45.640.*
- (3) *The equal employment provisions of KRS 45.560 to 45.640 may be met in part by a contractor by subcontracting to a minority contractor or subcontractor. For the provisions of KRS 45.560 to 45.640, a minority contractor or subcontractor shall mean a business that is owned and controlled by one or more persons disadvantaged by racial or ethnic circumstances.*

KRS 45.630 Termination of existing employee not required, when

Any provision of KRS 45.560 to 45.640 notwithstanding, no contractor shall be required to terminate an existing employee upon proof that that employee was employed prior to the date of the contract.

KRS 45.640 Minimum skills

Nothing in KRS 45.560 to 45.640 shall require a contractor to hire anyone who fails to demonstrate the minimum skills required to perform a particular job.

17. EQUAL EMPLOYMENT OPPORTUNITY AFFIRMATIVE ACTION POLICY

It is the policy of _____
to assure that all applicants for employment and all employees are treated on a fair and equitable basis without regard to their race, religion, sex, color, handicap, natural origin or age.

Such action shall include employment, promotion, demotion, recruitment or recruitment advertising, layoff or termination, rates of pay and other forms of compensation, and selection for training, whether apprenticeship and/or on-the-job-training.

Furthermore, this company agrees to make special recruitment efforts to hire the protected class whenever feasible. This company also agrees to adhere to all applicable federal, state, and local laws relating to Equal Employment Opportunity for all individuals.

_____ has been appointed Equal Employment Compliance (EEOC) Officer and shall be available for counseling, answering of questions in regards to this company policy, and to hear any complaints of discrimination. The EEOC Officer may be reached by calling _____.

Signature: _____
(Bidding Contractor)

Title: _____

Date: _____

18. WORKFORCE ANALYSIS FORM

Name of Organization: _____

Categories	Total	White (Not Hispanic or Latino)		Hispanic or Latino		Black or African- American (Not Hispanic or Latino)		Native Hawaiian and Other Pacific Islander (Not Hispanic or Hispanic or Latino)		Asian (Not Hispanic or Latino)		American Indian or Alaskan Native (not Hispanic or Latino)		Two or more races (Not Hispanic or Latino)		Total		
		M	F	M	F	M	F	M	F	M	F	M	F	M	F	M	F	
Administrators																		
Professionals																		
Superintendents																		
Supervisors																		
Foremen																		
Technicians																		
Protective Service																		
Para-Professionals																		
Office/Clerical																		
Skilled Craft																		
Service/Maintenance																		
Total:																		

Prepared by: _____ Date: ____/____/____

(Name and Title)

Revised 2015-Dec-15

19. EVIDENCE OF INSURABILITY

LEXINGTON-FAYETTE URBAN COUNTY GOVERNMENT CONSTRUCTION PROJECT
 (Use separate form for each Agency or Brokerage agreeing to provide coverage)

Names Insured: _____ Employee ID: _____

Address: _____ Phone: _____

Project to be insured: _____

In lieu of obtaining certificates of insurance at this time, the undersigned agrees to provide the above Named Insured with the minimum coverage listed below. These are outlined in the Insurance and Risk Management of Part V (Special Conditions), including all requirements, and conditions:

Section Items	Coverage	Minimum Limits and Policy Requirements	Limits Provided To Insured	Name of Insurer	A.M. Best's Code	Rating
SC-3, Section 2, Part 4.1 – see provisions	CGL	\$1,000,000 per occ. And \$2,000,000 aggregate	\$			
SC-3, Section 2, Part 4.1 – see provisions	AUTO	\$2,000,000/per occ.	\$			
SC-3, Section 2, Part 4.1 – see provisions	WC	Statutory w /endorsement as noted	\$			

Section 2 includes required provisions, statements regarding insurance requirements, and the undersigned agrees to abide by all provisions for the coverage's checked above unless stated otherwise when submitting.

Agency or Brokerage _____ Name of Authorized Representative _____

Street Address _____ Title _____

City _____ State _____ Zip _____ Authorized Signature _____

Telephone Number _____ Date _____

NOTE: Authorized signatures may be the agent's if agent has placed insurance through an agency agreement with the insurer. If insurance is brokered, authorized signature must be that of authorized representative of insurer.

IMPORTANT: Contract may not be awarded if a completed and signed copy of this form for all coverage's listed above is not provided with the bid.

20. DEBARRED FIRMS

PROJECT NAME: _____

BID NUMBER: _____

**LEXINGTON-FAYETTE URBAN COUNTY GOVERNMENT
LEXINGTON, KY**

All prime Contractors shall certify that Subcontractors have not and will not be awarded to any firms that has been debarred for noncompliance with the Federal Labor Standards, Title VI of the Civil Rights Act of 1964 As Amended, Executive Order 11246 As Amended or any other Federal Law.

All bidders shall complete the attached certification in duplicate and submit both copies to the Owner with the bid proposal. The Owner (grantee) shall transmit one copy to the Lexington-Fayette Urban County Government, Division of Community Development, within fourteen (14) days after bid opening.

The undersigned hereby certifies that the firm of _____ has not and will not award a subcontract, in connection with any contract award to it as the result of this bid, to any firm that has been debarred for noncompliance with the Federal labor Standards, Title VI of the civil Rights Act of 1964, Executive Order 11246 as amended or any Federal Law.

Name of Firm Submitting Bid

Signature of Authorized Official

Title

Date

21. DEBARMENT CERTIFICATION

All contractors/subcontractors shall complete the following certification and submit it with the bid proposal.

The contractor/subcontractor certifies in accordance with Executive Order 12549 (Debarment and Suspension 2/18/86) that to the best of its knowledge and belief, that it and its principals:

- 1) Are not presently debarred, suspended, proposed for debarment, declared negligible, or voluntarily excluded from covered transactions or contract by any Federal department or agency for noncompliance with the Federal Labor Standards, Title VI of the Civil Rights Act of 1964 as amended, Executive Order 11246 as amended or any other Federal law;
 - a) Have not within a three year period preceding this proposal been convicted of or had a civil judgment rendered against them for commission of fraud or a criminal offense in connection with obtaining, attempting to obtain, or performing a public (Federal, State or local) transaction or contract under a public transaction; violation of Federal or State antitrust statutes or commission of embezzlement, theft, forgery, bribery, falsification or destruction of records, making false statements, or receiving stolen property;
 - b) Are not presently indicted for or otherwise criminally or civilly charged by a government entity (Federal, State or local) with commission of any of the offenses enumerated in paragraph (1)(a) of this certification; and
 - c) Have not within a three year period preceding this bid has one or more public (Federal, State or local) transactions or contracts terminated for cause or default.
- 2) Where the contractor is unable to certify to any of the statements in this certification, such prospective contractors shall attach an explanation to this certification form.

Firm Name: _____

Project: _____

Printed Name and Title of Authorized Representative: _____

Signature: _____

Date: _____

22. PROVISIONS RELATIVE TO SENATE BILL 258 (1994)

During the performance of the contract, the contractor agrees to comply with the applicable provisions of:

1. KRS 136 Corporation and Utility Tax
2. KRS 139 Sales and Use Taxes
3. KRS 141 Income Taxes
4. KRS 337 Wages and Hours
5. KRS 338 Occupational Safety and Health of Employees
6. KRS 341 Unemployment Compensation
7. KRS 342 Workers Compensation

Any final determinations of a violation by the contractor within the previous (5) years pursuant to the applicable statutes above are revealed as follows:

23. EXECUTIVE BRANCH CODE OF ETHICS

In the 1992 regular legislative session, the General Assembly passed and Governor Brereton Jones signed Senate Bill 63 (codified as KRS 11A), the Executive Branch Code of Ethics, which states, in part:

KRS 11A.040 (6) provides:

No present or former public servant shall, within six (6) months of following termination of his office or employment, accept employment, compensation or other economic benefit from any person or business that contracts or does business with the state in matters in which he was directly involved during his tenure. This provision shall not prohibit an individual from returning to the same business, firm, occupation, or profession in which he was involved prior to taking office or beginning his term of employment, provided that, for a period of six (6) months, he personally refrains from working on any matter in which he was directly involved in state government. This subsection shall not prohibit the performance of ministerial functions, including, but not limited to, filing tax returns, filing applications for permits or licenses, or filing incorporation papers.

KRS 11A.040 (8) states:

A former public servant shall not represent a person in a matter before a state agency in which the former public servant was directly involved, for a period of one (1) year after the latter of:

- a) The date of leaving office or termination of employment; or
- b) The date the term of office expires to which the public servant was elected.

This law is intended to promote public confidence in the integrity of state government and to declare as public policy the idea that state employees should view their work as a public trust and not as a way to obtain private benefits.

If you have worked for the executive branch of state government within the past six months, you may be subject to the law's prohibitions. The law's applicability may be different if you hold elected office or are contemplating representation of another before a state agency.

Also, if you are affiliated with a firm which does business with the state and which employs former state executive-branch employees, you should be aware that the law may apply to them.

In case of doubt, the law permits you to request an advisory opinion from the Executive Branch Ethics Commission, Room 136, Capitol Building, 700 Capitol Avenue, Frankfort, Kentucky 40601; telephone (502)564-7954.

Signature of Authorized Official

Title

Date

END OF SECTION



PART IV
GENERAL CONDITIONS
TABLE OF CONTENTS

Article Number	Title	Page
1.	DEFINITIONS	GC-6
2.	PRELIMINARY MATTERS.....	GC-10
3.	CONTRACT DOCUMENTS: INTENT, CONFLICTS, AMENDING AND REUSE	GC-11
4.	AVAILABILITY OF LANDS; PHYSICAL CONDITIONS; REFERENCE POINTS	GC-13
5.	CONTRACTOR'S RESPONSIBILITIES	GC-16
6.	OTHER WORK	GC-27
7.	OWNER'S RESPONSIBILITIES	GC-28
8.	CONSULTANT'S STATUS DURING CONSTRUCTION	GC-28
9.	CHANGES IN THE WORK	GC-31
10.	CHANGE OF CONTRACT PRICE.....	GC-32
11.	CHANGE OF CONTRACT TIME	GC-39
12.	WARRANTY AND GUARANTEE; TESTS AND INSPECTIONS; CORRECTION, REMOVAL OR ACCEPTANCE OF DEFECTIVE WORK.....	GC-39
13.	PAYMENTS TO CONTRACTOR AND COMPLETION	GC-43
14.	SUSPENSION OF WORK AND TERMINATION	GC-46
15.	MISCELLANEOUS	GC-49

DETAILED TABLE OF CONTENTS OF GENERAL CONDITIONS

1. Definitions
2. Preliminary Matters
 - 2.1 Delivery of Bonds
 - 2.2 Copies of Documents
 - 2.3 Commencement of Contract Time; Notice to Proceed
 - 2.4 Starting the Project
 - 2.5 Before Starting Construction
 - 2.6 Submittal of Schedules
 - 2.7 Preconstruction Conference
 - 2.8 Finalizing Schedules
3. Contract Documents, Intent, Conflicts, Amending, and Reuse
 - 3.1 General
 - 3.2 Intent
 - 3.3 Conflicts
 - 3.4 Amending and Supplementing Contract Documents
 - 3.5 Reuse of Documents
4. Availability of Lands, Physical Conditions, Reference Points
 - 4.1 Availability of Lands
 - 4.2 Physical Conditions
 - 4.3 Physical Conditions - Underground Facilities
 - 4.4 Reference Points
5. CONTRACTOR'S Responsibilities
 - 5.1 Supervision
 - 5.2 Superintendence
 - 5.3 Labor
 - 5.4 Start-Up and Completion of Work
 - 5.5 Materials and Equipment
 - 5.6 Adjusting Progress Schedule
 - 5.7 Substitutes or "Or-Equal" Items
 - 5.8 Subcontractors, Suppliers and Others
 - 5.9 Patent Fees and Royalties
 - 5.10 Permits
 - 5.11 Laws and Regulations
 - 5.12 Taxes
 - 5.13 Use of Premises

- 5.14 Record Drawings
- 5.15 Shop Drawings and Samples
- 5.16 Continuing the Work
- 5.17 Erosion and Sediment Control

- 6. Other Work
 - 6.1 Related Work at Site
 - 6.2 Other Contractors or Utility Owners
 - 6.3 Delays Caused By Others
 - 6.4 Coordination

- 7. OWNER'S Responsibilities
 - 7.1 Communications
 - 7.2 Data and Payments
 - 7.3 Lands, Easements, and Surveys
 - 7.4 Change Orders
 - 7.5 Inspections, Tests, and Approvals
 - 7.6 Stop or Suspend Work

- 8. CONSULTANT'S Status During Construction
 - 8.1 OWNER'S Representative
 - 8.2 Visits to Site
 - 8.3 Project Representation
 - 8.4 Clarification and Interpretations
 - 8.5 Authorized Variations in Work
 - 8.6 Rejecting Defective Work
 - 8.7 Shop Drawings
 - 8.8 Change Orders
 - 8.9 Payments
 - 8.10 Determinations for Unit Prices
 - 8.11 Decisions on Disputes
 - 8.12 Limitations on CONSULTANT'S Responsibilities

- 9. Changes in the Work
 - 9.1 OWNER May Order Changes
 - 9.2 Claims
 - 9.3 Work Not in Contract Documents
 - 9.4 Change Orders
 - 9.5 Notice of Change

10. Change of Contract Price
 - 10.1 Total Compensation
 - 10.2 Claim for Increase or Decrease in Price
 - 10.3 Value of Work
 - 10.4 Cost of the Work
 - 10.5 Not to Be Included in Cost of the Work
 - 10.6 CONTRACTOR'S Fee
 - 10.7 Itemized Cost Breakdown
 - 10.8 Cash Allowance
 - 10.9 Unit Price Work

11. Change of Contract Time
 - 11.1 Change Order
 - 11.2 Justification for Time Extension
 - 11.3 Time Limits

12. Warranty and Guarantee; Tests and Inspections; Correction, Removal or Acceptance of Defective Work
 - 12.1 Warranty and Guarantee
 - 12.2 Access to Work
 - 12.3 Tests and Inspections
 - 12.4 OWNER May Stop Work
 - 12.5 Correction or Removal of Defective Work
 - 12.6 One Year Correction Period
 - 12.7 Acceptance of Defective work
 - 12.8 Owner May Correct Defective Work

13. Payments to CONTRACTOR and Completion
 - 13.1 Schedule of Values
 - 13.2 Application for Progress Payments
 - 13.3 CONTRACTOR'S Warranty of Title
 - 13.4 Review of Application for Progress Payments
 - 13.5 Partial Utilization
 - 13.6 Final Inspection
 - 13.7 Final Application for Payment
 - 13.8 Final Payment and Acceptance
 - 13.9 CONTRACTOR'S Continuing Obligation
 - 13.10 Waiver of Claims

14. Suspension of Work and Termination

- 14.1 OWNER May Suspend Work
- 14.2 OWNER May Terminate
- 14.3 CONTRACTOR'S Services Terminated
- 14.4 Payment After Termination
- 14.5 CONTRACTOR May Stop or Terminate

15. Miscellaneous

- 15.1 Claims for Injury or Damage
- 15.2 Non-Discrimination in Employment
- 15.3 Temporary Street Closing or Blockage
- 15.4 Percentage of Work Performed by Prime CONTRACTOR
- 15.5 Clean-up
- 15.6 General
- 15.7 Debris Disposal

END OF SECTION

PART IV

GENERAL CONDITIONS

1. DEFINITIONS

Wherever used in these General Conditions or the other Contract Documents, the following terms have the meanings indicated which are applicable to both the singular and plural thereof.

1.1 Addenda

Written or graphic instruments issued prior to the opening of Bids which clarify, correct, or change the Bid Documents or the Contract Documents.

1.2 Agreement

The written agreement between OWNER and CONTRACTOR covering the Work to be performed; other Contract Documents are attached to the Agreement and made a part thereof as provided therein.

1.3 Application for Payment

The form accepted by CONSULTANT which is to be used by CONTRACTOR in requesting progress or final payments and which is to include such supporting documentation as is required by the Contract Documents.

1.4 Bid

The offer or proposal of the Bidder submitted on the prescribed form setting forth the prices for the Work to be performed.

1.5 Bidder

An individual, partnership, or corporation, who submit a Bid for a prime contract with the OWNER, for the Work described in the proposed Contract Documents.

1.6 Bonds

Bid, performance and payment bonds and other instruments of security.

1.7 Calendar Day

A calendar day of twenty-four hours measured from midnight to the next midnight shall constitute a day.

1.8 Change Order

A document recommended by CONSULTANT, which is signed by CONTRACTOR and OWNER and authorizes an addition, deletion or revision in the Work, or an adjustment in the Contract Price or the Contract Time, issued on or after the Effective Date of the Agreement.

- 1.9 Contract Documents**
The Advertisement for Bidders, Information for Bidders, Agreement, Addenda (which pertain to the Contract Documents), CONTRACTOR'S Bid (including documentation accompanying the Bid and any post-bid documentation submitted prior to the Notice of Award) when attached as an exhibit to the Agreement, the Bonds, these General Conditions, the Special Conditions, the Specifications and the Drawings as the same are more specifically identified in the Agreement, together with all amendments, modifications and supplements.
- 1.10 Contract Unit Price**
The monies payable by OWNER to CONTRACTOR under the Contract Documents as stated in the Agreement. Unit Prices are to be firm for the term of this Contract.
- 1.11 Contract Time**
The number of consecutive calendar days between the date of issuance of the Notice to Proceed and the contract completion date.
- 1.12 CONTRACTOR**
The person, firm or corporation with whom OWNER has entered into the Agreement.
- 1.13 Defective**
An adjective which when modifying the word Work refers to Work that is unsatisfactory, faulty or deficient, or does not conform to the Contract Documents, or does not meet the requirements of any inspection, reference standard, test or approval referred to in the Contract Documents, or has been damaged prior to CONSULTANT'S recommendation of final payment (unless responsibility for the protection thereof has been assumed by OWNER).
- 1.14 Drawings**
The drawings which show the character and scope of the Work to be performed and which have been prepared or approved by CONSULTANT and are referred to in the Contract Documents.
- 1.15 Effective Date of the Agreement**
The date indicated in the Agreement on which it becomes effective.
- 1.16 CONSULTANT**
The Lexington-Fayette Urban County Government or its authorized representative.
- 1.17 Field Order**
A documented order issued by CONSULTANT which orders minor changes in the Work, but which does not involve a change in the Contract Price or the Contract Time.

1.18 Giving Notice

Whenever any provision of the Contract Documents requires the giving of written notice, it will be deemed to have been validly given if delivered in person to the individual or to a member of the firm or to an officer of the corporation for whom it is intended, or if delivered at or sent by registered or certified mail, postage prepaid, to the last business address known to the giver of the notice.

1.19 Laws and Regulations

Laws, rules, regulations, ordinances, codes and/or orders.

1.20 Notice of Award

The written notice by OWNER to the apparent successful bidder stating that upon compliance by the apparent successful bidder with the conditions enumerated therein, within the time specified, OWNER will sign and deliver the Agreement.

1.21 Notice to Proceed

A written notice given by OWNER to CONTRACTOR fixing the date on which the Contract Time will commence to run and on which CONTRACTOR shall start to perform CONTRACTOR'S obligations under the Contract Documents.

1.22 OWNER

The Lexington-Fayette Urban County Government.

1.23 Partial Utilization

Placing a portion of the Work in service for the purpose for which it is intended (or related purpose) before reaching Completion for all the Work.

1.24 Project

The total construction of which the Work to be provided under the Contract Documents may be the whole, or a part as indicated elsewhere in the Contract Documents.

1.25 Inspector

The authorized representative who is assigned to the site or any part thereof.

1.26 Shop Drawings

All drawings, diagrams, illustrations, schedules and other data which are specifically prepared by or for CONTRACTOR to illustrate some portion of the Work and all illustrations, brochures, standard schedules, performance charts, instructions, diagrams and other information prepared by a Supplier and submitted by CONTRACTOR to illustrate material or equipment for some portion of the Work.

1.27 Specifications

Those portions of the Contract Documents consisting of written technical descriptions of materials, equipment, construction systems, standards and

workmanship as applied to the Work and certain administrative details applicable thereto.

1.28 Standard Specifications

The "Standard Specifications for Road and Bridge Construction", Transportation Cabinet, Department of Highways, Commonwealth of Kentucky, current edition. MUTCD shall refer to the "Manual of Uniform Traffic Control Devices.

1.29 Subcontractor

An individual, firm or corporation having a direct contract with CONTRACTOR or with any other Subcontractor for the performance of a part of the Work at the site.

1.30 Special Conditions

The part of the Contract Documents which amends or supplements these General Conditions.

1.31 Supplier

A manufacturer, fabricator, supplier, distributor, materialman or vendor.

1.32 Underground Facilities

All pipelines, conduits, ducts, cables, wires, manholes, vaults, tanks, tunnels or other such facilities or attachments, and any encasements containing such facilities which have been installed underground to furnish any of the following services or materials: electricity, gases, steam, liquid petroleum products, telephone or other communications, cable television, sewage and drainage removal, traffic or other control systems or water.

1.33 Unit Price Work

Not applicable

1.34 Work

The entire completed construction or the various separately identifiable parts thereof required to be furnished under the Contract Documents. Work is the result of performing services, furnishing labor and furnishing and incorporating materials and equipment into the construction, all as required by the Contract Documents.

1.35 Time Period

When any period of time is referred to in the Contract Documents by days, it will be computed to exclude the first and include the last day of such period. If the last day of any such period falls on a Saturday or Sunday or on a day made a legal holiday by the law of the applicable jurisdiction, such day will be omitted from the computation.

2. PRELIMINARY MATTERS

2.1 Delivery of Bonds

When the CONTRACTOR delivers the executed Agreements to OWNER, CONTRACTOR shall also deliver to OWNER, such Bonds, Insurance Certificate, and Power of Attorney as CONTRACTOR may be required to furnish.

2.2 Copies of Documents

Owner shall furnish to CONTRACTOR up to three copies (unless otherwise specified in the Special Conditions) of the Contract Documents as are reasonably necessary for the execution of the Work. Additional copies will be furnished, upon request, at the cost of reproduction.

2.3 Commencement of Contract Time; Notice to Proceed

The Contract Time will commence to run on the day specified in the Notice to Proceed.

2.4 Starting the Project

CONTRACTOR shall start to perform the Work on the date when the Contract Time commences to run, but no Work shall be done at the site prior to the date on which the Contract Time commences to run.

2.5 Before Starting Construction

Before undertaking each part of the Work, CONTRACTOR shall carefully study and compare the Contract Documents and check and verify pertinent figures shown thereon and all applicable field measurements. CONTRACTOR shall promptly report in writing to CONSULTANT any conflict, error or discrepancy which CONTRACTOR may discover and shall obtain a written interpretation or clarification from CONSULTANT before proceeding with any Work affected thereby; however, CONTRACTOR shall not be liable to OWNER or CONSULTANT for failure to report any conflict, error or discrepancy in the Contract Documents, unless CONTRACTOR had actual knowledge thereof or should reasonably have known thereof.

2.6 Submittal of Schedules

Within ten days after the effective date of the Agreement (unless otherwise specified) CONTRACTOR shall submit to CONSULTANT for review:

2.6.1 an estimated progress schedule indicating the starting and completion dates of the various stages of the Work;

2.6.2 a preliminary schedule of Shop Drawing submissions; and

2.6.3 a preliminary schedule of values for all of the Work which will include quantities and prices of items aggregating the Contract Price and will subdivide the Work into costs per labor and materials by specification

section to serve as the basis for progress payments during construction. Such prices will include an appropriate amount of overhead and profit applicable to each item of Work which will be confirmed in writing by CONTRACTOR at the time of submission. Schedule of values shall be submitted on AIA G702/703 forms, or approved equal.

2.7 Preconstruction Conference

Before CONTRACTOR starts the Work at the proposed site, a conference attended by CONTRACTOR, CONSULTANT, EEO-Affirmative Action Officer, and other appropriate parties will be held to discuss the following issues: (1) The scheduling of the Work to be completed; (2) The procedures for handling shop drawings and other submittals; (3) The processing of applications for payment; (4) The establishment of an understanding among the involved parties in regard to the proposed project; (5) The establishment of procedures for effectively implementing the LFUCG's 10% minimum DBE goals; and (6) Requirement for Mechanic's Lien on Partial Applications for Payment.

2.8 Finalizing Schedules

At least ten days before submission of the first Application for Payment a conference attended by CONTRACTOR, CONSULTANT and others as appropriate will be held to finalize the schedules submitted in accordance with paragraph 2.6. The finalized progress schedule will be acceptable to CONSULTANT as providing orderly progression of the Work to completion within the Contract Time, but such acceptance will neither impose on CONSULTANT responsibility for the progress or scheduling of the Work nor relieve CONTRACTOR from full responsibility thereof. The finalized schedule of Shop Drawing submissions will be acceptable to CONSULTANT as providing a workable arrangement for processing the submissions. The finalized schedule of values will be acceptable to CONSULTANT as to form and substance.

3. CONTRACT DOCUMENTS: INTENT, CONFLICTS, AMENDING AND REUSE

3.1 General

The Contract Documents comprise the entire agreement between OWNER and CONTRACTOR concerning the Work. The Contract Documents are complementary; what is called for by one is as binding as if called for by all. The Contract Documents will be construed in accordance with the law of the place of the Project.

3.2 Intent

It is the intent of the Contract Documents to describe a functionally complete Project (or part thereof) to be constructed in accordance with the Contract Documents. Any Work, materials or equipment that may reasonably be inferred from the Contract Documents as being required to produce the intended result will be supplied whether or not specifically called for. When words which have a well-known technical or trade meaning are used

to describe Work, materials or equipment such words shall be interpreted in accordance with that meaning. Reference to standard specifications, manuals or codes of any technical society, organization or association, or to the laws or regulations of any governmental authority, whether such reference be specific or by implication, shall mean the latest standard specification, manual, code or laws or regulations in effect at the time of opening of Bids (or, on the Effective Date of the Agreement if there were no Bids), except as may be otherwise specifically stated. However, no provision of any referenced standard specification, manual or code (whether or not specifically incorporated by reference in the Contract Documents) shall be effective to change the duties and responsibilities of OWNER, CONTRACTOR or CONSULTANT, or any of their consultants, agents or employees from those set forth in the Contract Documents, nor shall it be effective to assign to CONSULTANT, or any of CONSULTANT'S consultants, agents or employees, any duty or authority to supervise or direct the furnishing or performance of the Work or any duty or authority to undertake responsibility contrary to the provisions of paragraph 8.12.3 or 8.12.4. Clarifications and interpretations of the Contract Documents shall be issued by CONSULTANT as provided in paragraph 8.4.

3.3 Conflicts

If, during the performance of the Work, CONTRACTOR finds a conflict, error or discrepancy in the Contract Documents, CONTRACTOR shall so report to CONSULTANT in writing at once and before proceeding with the Work affected thereby shall obtain a written interpretation or clarification from CONSULTANT; however, CONTRACTOR shall not be liable to OWNER or CONSULTANT for failure to report any conflict, error or discrepancy in the Contract Documents unless CONTRACTOR had actual knowledge thereof or should reasonably have known thereof.

In resolving such conflicts, errors and discrepancies, the documents shall be given precedence in the following order:

1. Agreement
2. Field and Change Orders
3. Addenda
4. Special Conditions
5. Instruction to Bidders
6. General Conditions
7. Specifications and Drawings

Figure dimension on drawings shall govern over scale dimensions and detailed Drawings shall govern over general Drawings.

3.4 Amending and Supplementing Contract Documents

The Contract Documents may be amended to provide for additions, deletions and revisions in the Work or to modify the terms and conditions thereof by means of a Change Order or a Field Order. Contract Price and Contract Time may only be changed by a Change Order.

3.5 Reuse of Documents

Neither CONTRACTOR nor any Subcontractor or Supplier or other person or organization performing or furnishing any of the Work under a direct or indirect contract with OWNER shall have or acquire any title to or ownership rights in any of the Drawings, Specifications or other documents (or copies of any thereof) prepared by or bearing the seal of CONSULTANT; and they shall not reuse any of them on extensions of the Project or any other project without written consent of OWNER and CONSULTANT and specific written verification or adaptation by CONSULTANT.

4. AVAILABILITY OF LANDS; PHYSICAL CONDITIONS, REFERENCE POINTS

4.1 Availability of Lands

OWNER shall furnish, as indicated in the Contract Documents, the lands upon which the Work is to be performed, rights-of-way and easements for access thereto, and such other lands which are designated for the use of CONTRACTOR. Easements for permanent structures or permanent changes in existing facilities will be obtained and paid for by OWNER, unless otherwise provided in the Contract Documents. If CONTRACTOR believes that any delay in OWNER'S furnishing these lands, rights-of-way or easements entitles CONTRACTOR to an extension of the Contract Time, CONTRACTOR may make a claim therefor as provided in Article 11. CONSULTANT shall determine if the claim is legitimate or not. CONTRACTOR shall provide for all additional lands and access thereto that may be required for temporary construction facilities or storage of materials and equipment.

4.2 Physical Conditions

4.2.1 Explorations and Reports

Reference is made to the Special Conditions for identification of those reports of explorations and tests of subsurface conditions at the site that have been utilized by CONSULTANT in preparation of the Contract Documents. CONTRACTOR may rely upon the accuracy of the technical data contained in such reports, but not upon non-technical data, interpretations or opinions contained therein or for the completeness thereof for CONTRACTOR'S purposes. Except as indicated in the immediately preceding sentence and in paragraph 4.2.6, CONTRACTOR shall have full responsibility with respect to subsurface conditions at the site.

4.2.2 Existing Structures

Reference is made to the Special Conditions for identification of those drawings of physical conditions in or relating to existing surface and

subsurface structures (except Underground Facilities referred to in paragraph 4.3 which are at or contiguous to the site that have been utilized by CONSULTANT in preparation of the Contract Documents. CONTRACTOR may rely upon the accuracy of the technical data contained in such drawings, but not for the completeness thereof for CONTRACTOR'S purposes. Except as indicated in the immediately preceding sentence and in paragraph 4.2.6, CONTRACTOR shall have full responsibility with respect to physical conditions in or relating to such structures.

4.2.3 Report of Differing Conditions
If CONTRACTOR believes that:

4.2.3.1 any technical data on which CONTRACTOR is entitled to rely as provided in paragraphs 4.2.1 and 4.2.2 is inaccurate, or

4.2.3.2 any physical conditions uncovered or revealed at the site differ materially from that indicated, reflected or referred to in the Contract Documents,

CONTRACTOR shall, promptly after becoming aware thereof and before performing and WORK in connection therewith (except in an emergency) notify OWNER and CONSULTANT in writing about the inaccuracy or difference.

4.2.4 CONSULTANT'S Review

CONSULTANT will promptly review the pertinent conditions, determine the necessity of obtaining additional explorations or tests with respect thereto and advise CONTRACTOR of CONSULTANT'S findings and conclusions.

4.2.5 Possible Document Change

If CONSULTANT concludes that there is a material error in the Contract Documents or that because of newly discovered conditions a change I the Contract Documents is required, a Change Order will be issued as provided in Article 10 to reflect and document the consequences of the inaccuracy or difference.

4.2.6 Possible Price and Time Adjustments

In each such case, an increase or decrease in the Contract Price or an extension or shortening of the Contract Time, or any combination thereof, will be allowable to the extent that they are attributable to any such inaccuracy or difference.

4.3 Physical Conditions-Underground Facilities

4.3.1 Shown or Indicated

The information and data shown or indicated in the Contract Documents with respect to existing Underground Facilities at or contiguous to the site is

based on information and data furnished to OWNER or CONSULTANT by the owners of such underground facilities or by others. Unless it is otherwise expressly provided in the Special Conditions:

4.3.1.1 OWNER and CONSULTANT shall not be responsible for the accuracy or completeness of any such information or data; and,

4.2.1.2 CONTRACTOR shall have full responsibility for reviewing and checking all such information and data; for locating all underground facilities shown or indicated in the Contract Documents; for coordination of the Work with the owners of such underground facilities during construction; and for the safety and protection thereof and repairing any damage thereto resulting from the Work, the cost of all of which will be considered as having been included in the Contract Price.

4.3.2 Not Shown or Indicated

If an underground facility is uncovered or revealed at or contiguous to the site which was not shown or indicated in the Contract Documents and which CONTRACTOR could not reasonably have been expected to be aware of, CONTRACTOR shall, promptly after becoming aware thereof and before performing any Work affected thereby (except in an emergency), identify the owner of such Underground Facility and give written notice thereof to that owner and to OWNER and CONSULTANT. CONSULTANT will promptly review the underground facility to determine the extent to which the Contract Documents should be modified to reflect and document the consequences of the existence of the Underground Facility, and the Contract Documents will be amended or supplemented to the extent necessary. During such time, CONTRACTOR shall be responsible for the safety and protection of such underground facility. CONTRACTOR shall be allowed an increase in the Contract Price or an extension of the Contract Time, or both, to the extent that they are attributable to the existence of any underground facility that was not shown or indicated in the Contract Documents and which CONTRACTOR could not reasonably have been expected to be aware of.

4.4 Reference Points

OWNER shall provide engineering surveys to establish reference points for construction which in CONSULTANT'S judgment are necessary to enable CONTRACTOR to proceed with the Work. CONTRACTOR shall be responsible for laying out the Work (unless otherwise specified), shall protect and preserve the established reference points and shall make no changes or relocations without the prior written approval of OWNER. CONTRACTOR shall report to CONSULTANT whenever any reference point is lost or destroyed or requires relocation because of necessary changes in grades or locations, and shall be responsible for the accurate replacement or relocation of such reference points by a Registered Land Surveyor.

5. CONTRACTOR'S RESPONSIBILITIES

5.1 Supervision

CONTRACTOR shall supervise and direct the Work competently and efficiently, devoting such attention thereto and applying such skills and expertise as may be necessary to perform the Work in accordance with the Contract Documents. CONTRACTOR shall assure that all CONTRACTOR personnel (including subcontractors, etc.) conduct themselves in a courteous and respectful manner toward the CONSULTANT and the general public. CONTRACTOR shall keep at the Project Site during the progress of the Work a competent project manager/superintendent and all necessary assistants, all of whom shall be satisfactory to OWNER. OWNER reserves the right to reject CONTRACTOR'S construction superintendent and project management personnel if they are unsatisfactory to OWNER and upon such rejection CONTRACTOR shall designate and provide competent successors. Failure to comply with this condition of the Contract will result in immediate suspension of the Work. Following a review by the Commissioner of Public Works, the Contract may be terminated (see GC section 14). CONTRACTOR shall be solely responsible for the means, methods, techniques, sequences and procedures of construction, but CONTRACTOR shall not be responsible for the negligence of others in the design or selection of a specific means, method, technique, sequence or procedure of construction which is indicated in and required by the Contract Documents. CONTRACTOR shall be responsible to see that the finished Work complies accurately with the Contract Documents.

5.2 Superintendence

CONTRACTOR shall keep on the Work at all times during its progress a competent resident superintendent, who shall not be replaced without written notice to OWNER and CONSULTANT except under extraordinary circumstances. The superintendent will be CONTRACTOR'S representative at the site and shall have authority to act on behalf of CONTRACTOR. All communications given to the superintendent shall be as binding as if given to CONTRACTOR.

5.3 Labor

CONTRACTOR shall provide competent, suitably qualified personnel to survey and lay out the Work and perform construction as required by the Contract Documents. CONTRACTOR shall at all times maintain good discipline and order at the site. OWNER reserves the right to require CONTRACTOR to remove from the Project any of it's personnel, or subcontractor's personnel for violating LFUCG Policies, Rules or Regulations. Except in connection with the safety or protection of persons or the Work or property at the site or adjacent thereto, and except as otherwise indicated in the Contract Documents, all Work at the site shall be performed during regular working hours, and CONTRACTOR will not permit overtime work or the performance of Work on Saturday, Sunday or any legal holiday without OWNER'S written consent given after prior written notice to CONSULTANT.

5.4 Start-Up and Completion of Work

Unless otherwise specified, CONTRACTOR shall furnish and assume full responsibility for all materials, equipment, labor, transportation, construction equipment and machinery, tools, appliances, fuel, power, light, heat, telephone, water, sanitary facilities, temporary facilities and all other facilities and incidentals necessary for the furnishing, performance, testing, start-up and completion of the Work.

5.5 Materials and Equipment

All materials and equipment shall be of good quality and new, except as otherwise provided in the Contract Documents. If required by CONSULTANT, CONTRACTOR shall furnish satisfactory evidence (including reports of required tests) as to the kind and quality of materials and equipment. All materials and equipment shall be applied, installed, connected, erected, used, cleaned and conditioned in accordance with the instructions of the applicable supplier except as otherwise provided in the Contract Documents; but no provision of any such instructions will be effective to assign to CONSULTANT, or any of CONSULTANT'S consultants, agents or employees, any duty or authority to supervise or direct the furnishing or performance of the Work or any duty or authority to undertake responsibility contrary to the provisions of paragraph 8.12.3 or 8.12.4.

5.5.1 Not Clearly Specified or Indicated

In all instances where materials specified are obtainable in different sizes, weights, trade grades, qualities or finishes, etc., whose weights, trade grades, qualities or finishes, etc., are not clearly specified or indicated on the Drawings, the CONTRACTOR shall notify the CONSULTANT of all such instances at least five (5) days in advance of receiving the proposals. The CONSULTANT will then determine which size, weight, trade grade, quality, finish, etc., is required.

5.5.2 Coordination of Work

The CONTRACTOR shall see that for his own Work and for the work of each subcontractor, proper templates and patterns necessary for the coordination of the various parts of the Work are prepared. The CONTRACTOR shall furnish or require the Subcontractor to furnish such duplicates as will enable the Subcontractors to fit together and execute fully their respective portions of the Work.

5.6 Adjusting Progress Schedule

CONTRACTOR shall submit to CONSULTANT for acceptance (to the extent indicated in paragraph 2.8) adjustments in the progress schedule to reflect the impact thereon of new developments; these will conform generally to the progress schedule then in effect and additionally will comply with any provisions of the Contract Documents applicable thereto.

5.7 Substitutes or "Or-Equal" Items

5.7.1 General

Whenever materials or equipment are specified or described in the Contract Documents by using the name of a proprietary item or the name of a particular supplier, the naming of the item is intended to establish the type, function, and quality required. Unless the name is followed by words indicating that no substitution is permitted, materials or equipment of other Suppliers may be accepted by OWNER/CONSULTANT if sufficient information is submitted by CONTRACTOR to allow OWNER/CONSULTANT to determine that the material or equipment proposed is equivalent or equal to that named. The procedure for review by OWNER/CONSULTANT will include the following. Requests for review of substitute items of material and equipment will not be accepted by OWNER/CONSULTANT from anyone, other than CONTRACTOR. If CONTRACTOR wishes to furnish or use a substitute item of material or equipment, CONTRACTOR shall make written application to OWNER/CONSULTANT for acceptance thereof, certifying that the proposed substitute will perform adequately the functions and achieve the results called for by the general design, be similar and of equal substance to that specified and be suited to the same use as that specified. The application will state that the evaluation and acceptance of the proposed substitute will not prejudice CONTRACTOR'S achievement of completion on time, whether or not acceptance of the substitute for use in the Work will require a change in any of the Contract Documents (or in the provisions of any other direct contract with OWNER for work on the Project) to adapt the design to the proposed substitute and whether or not incorporation or use of the substitute in connection with the Work is subject to payment of any license fee or royalty. All variations of the proposed substitute from that specified will be identified in the application and available maintenance, repair and replacement service will be indicated. The application will also contain an itemized estimate of all costs that will result directly or indirectly from acceptance of such substitute, including costs of redesign and claims of other contractors affected by the resulting change, all of which shall be considered by OWNER/CONSULTANT in evaluating the proposed substitute. OWNER/CONSULTANT may require CONTRACTOR to furnish at CONTRACTOR'S expense additional data about the proposed substitute.

5.7.2 Substitutes

If a specific means, method, technique, sequence or procedure of construction is indicated in or required by the Contract Documents, CONTRACTOR may furnish or utilize a substitute means, method, sequence, technique or procedure of construction acceptable to OWNER/CONSULTANT, if CONTRACTOR submits sufficient information to allow OWNER/CONSULTANT to determine that the substitute proposed is equivalent to that indicated or required by the Contract Documents. The procedure for review by OWNER/CONSULTANT will be

similar to that provided in paragraph 5.7.1 as applied by OWNER/CONSULTANT.

5.7.3 OWNER/CONSULTANT'S Approval

OWNER/CONSULTANT will be allowed a reasonable time within which to evaluate each proposed substitute. OWNER/CONSULTANT will be the sole judge of acceptability, and no substitute will be ordered, installed or utilized without OWNER/CONSULTANT'S prior written acceptance which will be evidenced by either a Change Order or an approved Shop Drawing. OWNER may require CONTRACTOR to furnish at CONTRACTOR'S expense a special performance guarantee or other surety with respect to any substitute. OWNER/CONSULTANT will record time required by OWNER/CONSULTANT and OWNER/CONSULTANT'S consultants in evaluating substitutions proposed by CONTRACTOR and in making changes in the Contract Documents occasioned thereby. Whether or not OWNER/CONSULTANT accepts a proposed substitute, CONTRACTOR shall reimburse OWNER for the charges of OWNER/CONSULTANT and OWNER/CONSULTANT'S consultants for evaluating each proposed substitute.

5.8 **Subcontractors, Suppliers, and Others**

5.8.1 Acceptable to CONSULTANT

CONTRACTOR shall not employ any Subcontractor, Supplier or other person or organization (including those acceptable to OWNER and CONSULTANT as indicated in paragraph 5.8.2), whether initially or as a substitute, against whom OWNER or CONSULTANT may have reasonable objection. CONTRACTOR shall not be required to employ any Subcontractor, Supplier or other person or organization to furnish or perform any of the Work against whom CONTRACTOR has reasonable objection.

5.8.2 Objection After Due Investigation

If the Contract Documents require the identity of certain Subcontractors, Suppliers or other persons or organizations (including those who are to furnish the principal items of materials and equipment) to be submitted to OWNER in advance of the specified date prior to the Effective Date of the Agreement for acceptance by OWNER and CONSULTANT and if CONTRACTOR has submitted a list thereof, OWNER'S or CONSULTANT'S acceptance (either in writing or by failing to make written objection thereto by the date indicated for acceptance or objection in the bidding documents or the Contract Documents) of any such Subcontractor, Supplier or other person or organization so identified may be revoked on the basis of reasonable objection after due investigation, in which case CONTRACTOR shall submit an acceptable substitute. No acceptance by OWNER or CONSULTANT of any such Subcontractor, Supplier or other

person or organization shall constitute a waiver of any right of OWNER or CONSULTANT to reject defective Work.

5.8.3 Contractor Responsible for Acts of Subcontractors

The CONTRACTOR shall perform on the site, and with its own organization, work equivalent to at least fifty (50) percent of the total amount of Work to be performed under the Contract. This percentage may be reduced by a supplemental agreement to this Contract if, during performing the Work, the CONTRACTOR requests a reduction and the Urban County project manager determines that the reduction would be to the advantage of the Urban County Government.

The CONTRACTOR shall, at the time he submits his proposal for the Contract, notify the OWNER in writing of the names of Subcontractors proposed for the Work. He shall not employ any Subcontractor without the prior written approval of the OWNER.

CONTRACTOR shall be fully responsible to OWNER and CONSULTANT for all acts and omissions of the Subcontractors, Suppliers and other persons and organizations performing or furnishing any of the Work under a direct or indirect contract with CONTRACTOR just as CONTRACTOR is responsible for CONTRACTOR'S own acts and omissions. Nothing in the Contract Documents shall create any contractual relationship between OWNER or CONSULTANT and any such Subcontractor, Supplier or other person or organization, nor shall it create any obligation on the part of OWNER or CONSULTANT to pay or to see to the payment of any moneys due any such Subcontractor, Supplier or other person or organization except as may otherwise be required by Laws and Regulations.

5.8.4 Division of Specifications

The divisions and sections of the Specifications and the identifications of any Drawings shall not control CONTRACTOR in dividing the Work among Subcontractors or Suppliers or delineating the Work to be performed by any specific trade.

5.8.5 Agreement Between Contractor and Subcontractors

All Work performed for CONTRACTOR by a Subcontractor will be pursuant to an appropriate agreement between CONTRACTOR and the Subcontractor which specifically binds the Subcontractor to the applicable terms and conditions of the Contract Documents for the benefit of OWNER and CONSULTANT.

5.8.6 Statements and Comments by CONTRACTOR

Neither the CONTRACTOR, his employees, nor his subcontractors shall at any time make any statement or comment as to the project scope, nature, intention, design, or construction

method to any third party or parties without the explicit written consent of the OWNER.

Any third party requesting such information shall be referred to the OWNER or his representative.

Should there be any change from the original intent of the project as a result of any statement or comment by the contractor, his employees or subcontractors, contractor shall be held liable for any change in the scope, nature, design, or construction method and shall bear the full cost for the previously mentioned changes.

5.9 Patent Fees and Royalties

CONTRACTOR shall pay all license fees and royalties and assume all costs incident to the use in the performance of the Work or the incorporation in the Work of any invention, design, process, product or device which is the subject of patent rights or copyrights held by others.

5.10 Permits

Unless otherwise provided in the Special conditions, CONTRACTOR shall obtain and pay for all construction permits and licenses. OWNER shall assist CONTRACTOR, when necessary, in obtaining such permits and licenses. CONTRACTOR shall pay all governmental charges and inspection fees necessary for the prosecution of the Work, which are applicable at the time of opening of Bids, or if there are no Bids on the Effective Date of the Agreement. CONTRACTOR shall pay all charges of utility owners for connections to the Work, and OWNER shall pay all charges of such utility owners for capital costs related thereto such as plant investment fees.

5.11 Laws and Regulations

5.11.1 CONTRACTOR to Comply

CONTRACTOR shall give all notices and comply with all Laws and Regulations applicable to furnishing and performance of the Work. Except where otherwise expressly required by applicable Laws and Regulations, neither OWNER nor CONSULTANT shall be responsible for monitoring CONTRACTOR'S compliance with any Laws and Regulations.

5.11.2 Specifications and Drawings at Variance

If CONTRACTOR observes that the Specifications or Drawings are at variance with any Laws or Regulations, CONTRACTOR shall give CONSULTANT prompt written notice thereof, and any necessary changes will be authorized by one of the methods indicated in paragraph 3.4. If CONTRACTOR performs any Work knowing or having reason to know that it is contrary to such Laws, or Regulations, and without such notice to CONSULTANT, CONTRACTOR shall bear all costs arising therefrom; however, it shall not be CONTRACTOR'S primary responsibility to make certain that the Specifications and Drawings are in accordance with such Laws and Regulations.

Any party, firm or individual submitting a proposal pursuant to invitation must have paid all taxes owed to the Lexington-Fayette Urban County Government at the time the proposal is submitted, and must maintain a "current" status in regard to those taxes throughout the Contract. If applicable, business must be licensed in Fayette County.

5.12 Taxes

CONTRACTOR shall pay all sales, consumer, use and other similar taxes required to be paid by CONTRACTOR in accordance with the Laws and Regulations of the place of the Project which are applicable during the performance of the Work. Any party, firm or individual submitting a proposal pursuant to invitation must have paid all taxes owed to the Lexington-Fayette Urban County Government at the time the proposal is submitted, and must maintain a "current" status in regard to those taxes throughout the Contract. If applicable, business must be licensed in Fayette County.

5.13 Use of Premises

5.13.1 Project Site

CONTRACTOR shall confine construction equipment, the storage of materials and equipment and the operations of workers to the staging areas or work site areas identified in and permitted by the Contract Documents and other land and areas permitted by Laws and Regulations, rights-of-way, permits and easements, and shall not unreasonably encumber the premises with construction equipment or other materials or equipment. CONTRACTOR shall assume full responsibility for any damage to any such

land or area, or to the owner or occupant thereof or of any land or areas contiguous thereto, resulting from the performance of the Work. Should any claim be made against OWNER or CONSULTANT by any such owner or occupant because of the performance of the Work, CONTRACTOR shall promptly attempt to settle with such other party by agreement or otherwise resolve the claim by arbitration or at law. CONTRACTOR shall, to the fullest extent permitted by Laws and Regulations, indemnify and hold OWNER and CONSULTANT harmless from and against all claims, damages, losses and expenses (including, but not limited to, fees of engineers, architects, attorneys and other professionals and court and arbitration costs) arising directly, indirectly or consequentially out of any action, legal or equitable, brought by any such other party against OWNER or CONSULTANT to the extent based on a claim arising out of CONTRACTOR'S performance of the Work.

5.13.2 Clean UP

During the progress of the Work, CONTRACTOR shall keep the premises free from accumulations of waste materials, rubbish and other debris resulting from the Work. At the completion of the Work, CONTRACTOR shall remove all waste materials, rubbish and debris from and about the premises as well as all tools, appliances, construction equipment and machinery, and surplus materials, and shall leave the site clean and ready for occupancy by OWNER. CONTRACTOR shall restore to original condition all property not designated for alteration by the Contract Documents.

5.13.1 Loading of Structures

CONTRACTOR shall not load nor permit any part of any structure to be loaded in any manner that will endanger the structure, nor shall CONTRACTOR subject any part of the Work or adjacent property to stresses or pressures that will endanger it.

5.14 Record Drawings

CONTRACTOR shall maintain in a safe place at the site one record copy of all Drawings, Specifications, Addenda, Change Orders, Field Orders and written interpretations and clarifications (issued pursuant to paragraph 9.4) in good order and annotated to show all changes made during construction. These record documents together with all approved samples and a counterpart of all approved Shop Drawings will be available to CONSULTANT for reference. Upon completion of the Work, these record documents, samples and Shop Drawings will be delivered to CONSULTANT for OWNER.

5.15 Shop Drawings and Samples

5.15.1 Shop Drawing Submittals

After checking and verifying all field measurements and after complying

with applicable procedures specified, CONTRACTOR shall submit to CONSULTANT for review and approval in accordance with the accepted schedule of Shop Drawing submissions (see paragraph 2.8), or for other appropriate action if so indicated in the Special Conditions, five copies (unless otherwise specified) of all Shop Drawings, which will bear a stamp or specific written indication that CONTRACTOR has satisfied CONTRACTOR'S responsibilities under the Contract Documents with respect to the review of the submission. All submissions will be identified as CONSULTANT may require. The data shown on the Shop Drawings will be complete with respect to quantities, dimensions, specified performance and design criteria, materials and similar data to enable CONSULTANT to review the information as required.

5.15.2 Sample Submittals

CONTRACTOR shall also submit to CONSULTANT for review and approval with such promptness as to cause no delay in Work, all samples required by the Contract Documents. All samples will have been checked by and accompanied by a specific written indication that CONTRACTOR has satisfied CONTRACTOR'S responsibilities under the Contract Documents with respect to the review of the submission and will be identified clearly as to material, Supplier, pertinent data such as catalog numbers and the use for which intended.

5.15.3 Review by CONTRACTOR

Before submission of each Shop Drawing or sample CONTRACTOR shall have determined and verified all quantities, dimensions, specified performance criteria, installation requirements, materials, catalog numbers and similar data with respect thereto and reviewed or coordinated each Shop Drawing or sample with other Shop Drawings and samples and with the requirements of the Work and the Contract Documents.

5.15.4 Notice of Variation

At the time of each submission, CONTRACTOR shall give CONSULTANT specific written notice of each variation that the Shop Drawings or samples may have from the requirements of the Contract Documents, and, in addition, shall cause a specific notation to be made on each Shop Drawing submitted to CONSULTANT for review and approval of each such variation.

5.15.5 CONSULTANT'S Approval

CONSULTANT will review and approve with reasonable promptness Shop Drawings and samples, but CONSULTANT'S review and approval will be only for conformance with the design concept of the Project and for compliance with the information given in the Contract Documents and shall not extend to means, methods, techniques, sequences or procedures of construction (except where a specific means, method, technique, sequence or

procedure of construction is indicated in or required by the Contract Documents) or to safety precautions or programs incident thereto. The review and approval of a separate item as such will not indicate approval of the assembly in which the item functions. CONTRACTOR shall make corrections required by CONSULTANT, and shall return the required number of corrected copies of Shop Drawings and submit, as required, new samples for review and approval. CONTRACTOR shall direct specific attention in writing to revisions other than the corrections called for by CONSULTANT on previous submittals.

5.15.6 Responsibility for Errors and Omissions

CONSULTANT'S review and approval of Shop Drawings or samples shall not relieve CONTRACTOR from responsibility for any variation from the requirements of the Contract Documents unless CONTRACTOR has in writing called CONSULTANT'S attention to each such variation at the time of submission as required by paragraph 5.15.4 and CONSULTANT has given written approval of each such variation by a specific written notation thereof incorporated in or accompanying the Shop Drawing or sample approval; nor will any approval by CONSULTANT relieve CONTRACTOR from responsibility for errors or omissions in the Shop Drawings or from responsibility for having complied with the provisions of paragraph 5.15.3.

5.15.7 Cost of Related Work

Where a Shop or sample is required by the Specifications, any related Work performed prior to CONSULTANT'S review and approval of the pertinent submission will be the sole expense and responsibility of CONTRACTOR.

5.16 Continuing the Work

CONTRACTOR shall carry on the Work and adhere to the progress schedule during all disputes or disagreements with OWNER. No Work shall be delayed or postponed pending resolutions of any disputes or disagreements, except as permitted by paragraph 14.5 or as CONTRACTOR and OWNER may otherwise agree in writing.

5.17 Erosion and Sediment Control

5.17.1 General Environmental Requirements

The CONTRACTOR and Subcontractors performing work on projects on behalf of the OWNER shall comply with all applicable federal, state, and local environmental regulations and all requirements and conditions set forth in "special" permits including but not limited to Corp of Engineers 404 permits, 401 Water Quality Certifications, Stream Crossing and Floodplain Encroachment Permits.

Any fines or penalties resulting from the failure to comply with the terms of the federal, state or local permits or perform necessary corrective action are solely the obligation of the CONTRACTOR.

5.17.2 Stormwater Pollution Prevention

A. The CONTRACTOR shall exercise due care to prevent or minimize any damage to any stream or wetland from pollution by debris, sediment or other material. The operation of equipment and/or materials in a jurisdictional wetland is expressly prohibited. Water that has been used for washing or processing, or that contains oils, sediments or other pollutants shall not be discharged from the job site. Such waters shall be collected and properly disposed of by the CONTRACTOR in accordance with applicable local, state and federal law.

B. The CONTRACTOR is solely responsible for securing all required state and local permits associated with stormwater discharges from the project including, but not necessarily limited to the KY Notice of Intent to Disturb (NOI) for Coverage of Storm Water Discharges Associated with Construction Activities under the KPDES Storm Water General Permit KYR100000 and the LFUCG, Land Disturbance Permit. Permit application preparation and all required documentation are the responsibility of the CONTRACTOR. The CONTRACTOR is solely responsible for maintaining compliance with the stormwater pollution prevention plan or erosion and sediment control plan and ensuring the following:

- a. That the Stormwater Pollution Prevention Plan (SWPPP) or erosion control plan is current and available for review on site;
- b. That any and all stormwater inspection reports required by the permit are conducted by qualified personnel and are available for review onsite; and
- c. That all best management practices (BMPs) are adequately maintained and effective at controlling erosion and preventing sediment from leaving the site.

C. The CONTRACTOR shall provide the necessary equipment and personnel to perform any and all emergency measures that may be required to contain any spillage or leakage and to remove materials, soils or liquids that become contaminated. The collected spill material shall be properly disposed at the CONTRACTOR's expense.

D. Upon completion of the work and with the concurrence of the OWNER, the CONTRACTOR must file a Notice of Termination (NOT) of Coverage Under the KPDES General Permit for Storm Water Discharges Associated with Construction Activity with the appropriate local and state authorities.

E. Any fines or penalties resulting from the failure to comply with the terms of the state or local stormwater permits or perform necessary corrective action are solely the obligation of the CONTRACTOR.

6. OTHER WORK

6.1 Related Work at Site

OWNER may perform other work related to the Project at the site by OWNER'S own forces, have other work performed by utility owners or let other direct contracts therefor which shall contain General Conditions similar to these. If the fact that such other work is to be performed was not noted in the Contract Documents, written notice thereof will be given to CONTRACTOR prior to starting any such other work; and, if such performance will involve additional expense to CONTRACTOR or requires additional time, a Change Order to the Contract will be negotiated.

6.2 Other Contractors or Utility Owners

CONTRACTOR shall afford each utility owner and other contractor who is a party to such a direct contract (or OWNER, if OWNER is performing the additional work with OWNER'S employees) proper and safe access to the site and a reasonable opportunity for the introduction and storage of materials and equipment and the execution of such work, and shall properly connect and coordinate the Work with theirs. CONTRACTOR shall do all cutting, fitting and patching of the Work that may be required to make its several parts come together properly and integrate with such other work. CONTRACTOR shall not endanger any work of others by cutting, excavating or otherwise altering their work and will only cut or alter their work with the written consent of CONSULTANT and the others whose work will be affected. The duties and responsibilities of CONTRACTOR under this paragraph are for the benefit of such utility owners and other contractors to the extent that there are comparable provisions for the benefit of CONTRACTOR in said direct contracts between OWNER and such utility owners and other contractors.

6.3 Delays Caused by Others

If any part of CONTRACTOR'S Work depends for proper execution or results upon the work of any such other contractor or utility owner (or OWNER), CONTRACTOR shall inspect and promptly report to CONSULTANT in writing any delays, defects or deficiencies in such work that render it unavailable or unsuitable for such proper execution and results. CONTRACTOR'S failure so to report will constitute an acceptance of the other work as fit and proper for integration with CONTRACTOR'S Work except for latent or non-apparent defects and deficiencies in the other work.

6.4 Coordination

If OWNER contracts with others for the performance of other work on the Project at the site, the person or organization who will have authority and responsibility for coordination of the activities among the various prime contractors will be identified in the Special Conditions, and the specific matters to be covered by such authority and

responsibility will be itemized, and the extent of such authority and responsibilities will be provided, in the Special Conditions.

7. OWNER'S RESPONSIBILITIES

7.1 Communications

OWNER shall issue all communications to CONTRACTOR through CONSULTANT.

7.2 Data and Payments

OWNER shall furnish the data required of OWNER under the Contract Documents promptly after they are due.

7.3 Lands, Easements, and Surveys

OWNER'S duties in respect of providing lands and easements and providing engineering surveys to establish reference points are set forth in paragraphs 4.1 and 4.4. Paragraph 4.2 refers to OWNER'S identifying and making available to CONTRACTOR copies of reports of explorations and tests of subsurface conditions at the site and in existing structures which have been utilized by CONSULTANT in preparing the Drawings and Specifications.

7.4 Change Orders

OWNER is obligated to execute Change Orders as indicated in paragraph 9.4.

7.5 Inspections, Tests and Approvals

OWNER'S responsibility in respect to certain inspections, tests and approvals is set forth in paragraph 13.3.

7.6 Stop or Suspend Work

In connection with OWNER'S right to stop Work or suspend Work, see paragraph 12.4 and 14.1 Paragraph 14.2 deals with OWNER'S rights to terminate services of CONTRACTOR under certain circumstances.

8. CONSULTANT'S STATUS DURING CONSTRUCTION

8.1 OWNER'S Representative

CONSULTANT will be OWNER'S representative during the construction period. The duties and responsibilities and the limitations of authority of CONSULTANT as OWNER'S representative during construction are set forth in the Contract Documents and shall not be extended without written consent of OWNER and CONSULTANT.

8.2 Visits to Site

CONSULTANT will make visits to the site at intervals appropriate to the various stages of construction to observe the progress and quality of the executed Work and to determine, in general, if the Work is proceeding in accordance with the Contract Documents. CONSULTANT will not be required to make exhaustive or

continuous on-site inspections to check the quality or quantity of the Work. CONSULTANT'S efforts will be directed toward providing for OWNER a greater degree of confidence that the completed Work will conform to the Contract Documents. On the basis of such visits and on-site observations, CONSULTANT will keep OWNER informed of the progress of the Work and will endeavor to guard OWNER against defects and deficiencies in the Work.

8.3 Project Representation

CONSULTANT will provide an Inspector to assist CONSULTANT in observing the performance of the Work. If OWNER designates another agent to represent OWNER at the site who is not CONSULTANT'S agent or employee, the duties, responsibilities and limitations of authority of such other person will be as provided in the Special Conditions.

8.4 Clarifications and Interpretations

CONSULTANT will issue with reasonable promptness such written clarifications or interpretations of the requirements of the Contract Documents (in the form of Drawings or otherwise) as CONSULTANT may determine necessary, which shall be consistent with or reasonably inferable from the overall intent of the Contract Documents.

8.5 Authorized Variations in Work

CONSULTANT may authorize minor variations in the Work from the requirements of the Contract Documents which do not involve an adjustment in the Contract Price or the Contract Time and are consistent with the overall intent of the Contract Documents. These may be accomplished by a Field Order.

8.6 Rejecting Defective Work

CONSULTANT will have authority to disapprove or reject Work which CONSULTANT believes to be defective, and will also have authority to require special inspection or testing of the Work as provided in paragraph 12.3, whether or not the Work is fabricated, installed or completed.

8.7 Shop Drawings

In connection with CONSULTANT'S responsibility for Shop Drawings and samples, see paragraphs 5.15.1 through 5.16 inclusive.

8.8 Change Orders

In connection with CONSULTANT'S responsibilities as to Change Orders, see Articles 10, 11 and 12.

8.9 Payments

In connection with CONSULTANT'S responsibilities with respect to Applications for Payment, etc., see Article 13.

8.10 Determinations for Unit Prices

CONSULTANT will determine the actual quantities and classifications of Unit Price Work performed by CONTRACTOR.

CONSULTANT will review with CONTRACTOR CONSULTANT'S preliminary determinations on such matters before rendering a written decision thereon (by recommendation of an Application for Payment or otherwise).

8.11 Decision on Disputes

CONSULTANT will be the initial interpreter of the requirements of the Contract Documents and judge of the acceptability of the Work thereunder. Claims, disputes and other matters relating to the acceptability of the Work or the interpretation of the requirements of the Contract Documents pertaining to the performance and furnishing of the Work and claims under Articles 10 and 11 in respect of changes in the Contract Price or Contract Time will be referred initially to CONSULTANT in writing with a request for a formal decision in accordance with this paragraph, which CONSULTANT will render in writing within a reasonable time. Written notice of each such claim, dispute and other matter will be delivered to CONSULTANT promptly (but in no event later than thirty days) after the occurrence of the event giving rise thereto, and written supporting data will be submitted to CONSULTANT within sixty days after such occurrence unless CONSULTANT allows an additional period of time to ascertain more accurate data in support of the claim.

8.12 Limitations on CONSULTANT's Responsibilities

8.12.1 CONTRACTOR, Supplier, or Surety

Neither CONSULTANTS authority to act under this Article 8 or elsewhere in the Contract Documents nor any decision made by CONSULTANT in good faith either to exercise or not exercise such authority shall give rise to any duty or responsibility of CONSULTANT to CONTRACTOR, any Subcontractor, any Supplier, or any other person or organization performing any of the Work, or to any surety for any of them.

8.12.2 To Evaluate the Work

Whenever in the Contract Documents the terms "as ordered", "as directed", "as required", "as allowed", "as approved" or terms of like effect or import are used, or the adjectives "reasonable", "suitable", "acceptable", "proper", or "satisfactory" or adjectives or like "effect" or "import" are used to describe a requirement, direction, review or judgment of CONSULTANT as to the Work, it is intended that such requirement, direction, review or judgment will be solely to evaluate the Work for compliance with the Contract Documents (unless there is a specific statement indicating otherwise). The use of any such term or adjective shall not be effective to assign CONSULTANT any duty or authority to supervise or direct the furnishing or performance of the Work or any duty or authority to undertake responsibility contrary to the provisions of paragraph 8.12.3 or 8.12.4.

8.12.3 CONTRACTOR'S Means, Methods, Etc.

CONSULTANT will not be responsible for CONTRACTOR'S means, methods, techniques, sequences or procedures of construction, or the safety precautions and programs incident thereto, and CONSULTANT will not be responsible for CONTRACTOR'S failure to perform or furnish the Work in accordance with the Contract Documents.

8.12.4 Acts of Omissions of CONTRACTOR

CONSULTANT will not be responsible for the acts or omissions of CONTRACTOR or of any Subcontractor, any Supplier, or of any other person or organization performing or furnishing any of the Work.

9. CHANGES IN THE WORK

9.1 OWNER May Order Change

Without invalidating the Agreement and without notice to any surety, OWNER may, at any time or from time to time, order additions, deletions or revisions in the Work; these will be authorized by a Change Order. Upon receipt of such notice, CONTRACTOR shall promptly proceed with the Work involved which will be performed under the applicable conditions of the Contract Documents (except as otherwise specifically provided).

9.2 Claims

Claims for an increase or decrease in the Contract Price or an extension or shortening of the Contract Time that should be allowed as a result of a Change Order will be settled as provided for in Article 10 or Article 11.

9.3 Work Not in Contract Documents

CONTRACTOR shall not be entitled to an increase in the Contract Price or an extension of the Contract Time with respect to any Work performed that is not required by the Contract Documents as amended, modified and supplemented as provided in paragraph 3.4, except in the case of an emergency and except in the case of uncovering Work as provided in paragraph 12.3.4.

9.4 Change Orders

OWNER and CONTRACTOR shall execute appropriate Change Orders covering:

9.4.1 changes in the Work which are ordered by OWNER pursuant to paragraph 9.1, are required because of acceptance of defective Work under paragraph 12.7 or corrective defective Work under paragraph 12.8, or are agreed to by the parties;

9.4.2 changes in the Contract Price or Contract Time which are agreed to by the parties; and

9.4.3 changes in the Contract Price or Contract Time which embody the substance of any written decision rendered by CONSULTANT pursuant to paragraph 8.11; provided that, in lieu of executing any such Change Order, an appeal may be taken from any such decision in accordance with the provisions of the Contract Documents and applicable Laws and REGULATIONS, but during any such appeal, CONTRACTOR shall carry on the Work and adhere to the progress schedule as provided in paragraph 5.16.

9.5 Notice of Change

If notice of any change affecting the general scope of the Work or the provisions of the Contract Documents (including, but not limited to, Contract Price or Contract Time) is required by the provisions of any Bond to be given to a surety, the giving of any such notice will be CONTRACTOR'S responsibility, and the amount of each applicable Bond will be adjusted accordingly.

10. CHANGE OF CONTRACT PRICE

10.1 Total Compensation

The Contract Price constitutes the total compensation (subject to authorized adjustments) payable to CONTRACTOR for performing the Work. All duties, responsibilities and obligations assigned to or undertaken by CONTRACTOR shall be at his expense without change in the Contract Price.

10.2 Claim for Increase or Decrease in Price

The Contract Price may only be changed by a Change Order. Any claim for an increase or decrease in the Contract Price shall be based on written notice delivered by the CONTRACTOR to the CONSULTANT promptly (but in no event later than thirty days) after the occurrence of the event giving rise to the claim and stating the general nature of the claim. Notice of the amount of the claim with supporting data shall be delivered within sixty days after such occurrence (unless CONSULTANT allows an additional period of time to ascertain more accurate data in support of the claim) and shall be accompanied by CONTRACTOR'S written statement that the amount claimed covers all known amounts (direct, indirect, and consequential) to which the CONTRACTOR is entitled as a result of the occurrence of said event.

10.3 Value of Work

The value of any Work covered by a Change Order or of any claim for an increase or decrease in the Contract Price shall be determined in one of the following ways:

10.3.1 Unit Prices

Where the Work involved is covered by unit prices contained in the Contract Documents, by application of unit prices to the quantities of the items involved (subject to the provisions of paragraphs 10.9.1. through 10.9.3, inclusive).

10.3.2 Lump Sum

By mutual acceptance of a lump sum (which may include an allowance for overhead and profit not necessarily in accordance with paragraph 10.6.2.1).

10.3.3 Cost Plus Fee

On the basis of the Cost of the Work (determined as provided in paragraphs 10.4 and 10.5) plus a CONTRACTOR'S fee for overhead and profit (determined as provided in paragraphs 10.6 and 10.7).

10.4 **Cost of the Work**

The term Cost of the Work means the sum of all costs necessarily incurred and paid by CONTRACTOR in the proper performance of the Work. Except as otherwise may be agreed to in writing by OWNER, such costs shall be in amounts no higher than those prevailing in the locality of the Project; shall include only the following items; and shall not include any of the costs itemized in paragraph 10.5:

10.4.1 Payroll Costs

Payroll costs for employees in the direct employ of CONTRACTOR in the performance of the Work under schedules of job classifications agreed upon by OWNER and CONTRACTOR. Payroll costs for employees not employed full time on the Work shall be apportioned on the basis of their time spent on the Work. Payroll costs shall include, but not be limited to, salaries and wages plus the cost of fringe benefits which shall include social security contributions, unemployment, excise and payroll taxes, workers' or workmen's compensation, health and retirement benefits, bonuses, sick leave, vacation and holiday pay applicable thereto. Such employees shall include superintendents and foremen at the site. The expenses of performing Work after regular working hours, on Saturday, Sunday or legal holidays, shall be included in the above to the extent authorized by OWNER.

10.4.2 Materials and Equipment Costs

Cost of all materials and equipment furnished and incorporated in the Work, including costs of transportation and storage thereof, and Suppliers' field services required in connection therewith. All cash discounts shall accrue to CONTRACTOR unless OWNER deposits funds with CONTRACTOR with which to make payments, in which case the cash discounts shall accrue to OWNER. All trade discounts, rebates and refunds and all returns from sale of surplus materials and equipment shall accrue to OWNER, and CONTRACTOR shall make provisions so that they may be obtained.

10.4.3 Subcontractor Costs

Payments made by CONTRACTOR to the Subcontractors for Work performed by Subcontractors. If required by OWNER, CONTRACTOR shall obtain competitive bids from Subcontractors acceptable to CONTRACTOR and shall deliver such bids to OWNER who will then determine, with the advice of CONSULTANT, which bids will be accepted. If a subcontract provides that the Subcontractor is to be paid on the basis of Cost of the Work Plus a Fee, the Subcontractor's Cost of the Work shall be determined in the same manner as CONTRACTOR'S Cost of the Work. All subcontracts shall be subject to the other provisions of the Contract Documents insofar as applicable.

10.4.4 Special Consultant Costs

Costs of special consultants (including but not limited to engineers, architects, testing laboratories, surveyors, attorneys and accountants) employed for services specifically related to the Work.

10.4.5 Supplemental Costs

10.4.5.1 The proportion of necessary transportation, travel and subsistence expenses of CONTRACTOR'S employees incurred in discharge of duties connected with the Work.

10.4.5.2 Cost, including transportation and maintenance, of all materials, supplies, equipment, machinery, appliances, office and temporary facilities at the site and hand tools not owned by the workers, which are consumed in the performance of the Work, and cost less market value of such items used but not consumed which remain the property of CONTRACTOR.

10.4.5.3 Rentals of all construction equipment and machinery and the parts thereof whether rented from CONTRACTOR or others in accordance with rental agreements approved by OWNER with the advice of CONSULTANT, and the costs of transportation, loading, unloading, installation, dismantling and removal shall be in accordance with terms of said rental agreements. The rental of any such equipment, machinery or parts shall cease when the use thereof is no longer necessary for the Work.

10.4.5.4 Sales, consumer, use or similar taxes related to the Work, and for which CONTRACTOR is liable, imposed by Laws and Regulations.

10.4.5.5 Deposits lost for causes other than negligence of CONTRACTOR, any Subcontractor or anyone directly or indirectly employed by any of them or for whose acts any of them may be liable, and royalty payments and fees for permits and licenses.

10.4.5.6 Losses and damages (and related expenses), not compensated by insurance or otherwise, to the Work or otherwise sustained by CONTRACTOR in connection with the performance and furnishing of the Work (except losses and damages within the deductible amounts of property insurance established by OWNER), provided they have resulted from causes other than the negligence of CONTRACTOR, any Subcontractor, or anyone directly or indirectly employed by any of them or for whose acts any of them may be liable. Such losses shall include settlements made with the written consent and approval of OWNER. No such losses, damages and expenses shall be included in the Cost of the Work for the purpose of determining CONTRACTOR'S fee. If, however, any such loss or damage requires reconstruction and CONTRACTOR is placed in charge thereof, CONTRACTOR shall be paid a fee proportionate to that stated in paragraph 10.6.2 for services.

10.4.5.7 The cost of utilities, fuel and sanitary facilities at the site.

10.4.5.8 Minor expenses such as telegrams, long distance telephone calls, telephone service at the site, expressage and similar petty cash items in connection with the Work.

10.4.5.9 Cost of premiums for additional Bonds and insurance required because of changes in the Work and premiums for property insurance coverage within the limits of the deductible amounts established by OWNER.

10.5 Not to Be Included in Cost of the Work

The term Cost of the Work shall not include any of the following:

10.5.1 Costs of Officers and Executives

Payroll costs and other compensation of CONTRACTOR'S officers, executives, principals (of partnership and sole proprietorships), general managers, engineers, architects, estimators, attorneys, auditors, accountants, purchasing and contracting agents, expeditors, timekeepers, clerks and other personnel employed by CONTRACTOR whether at the site or in CONTRACTOR'S principal or a branch office for general administration of

the Work and not specifically included in the agreed upon schedule of job classifications referred to in paragraph 10.4.1 or specifically covered by paragraph 10.4.4 - all of which are to be considered administrative costs covered by the CONTRACTOR'S fee.

10.5.2 Principal Office

Expenses of CONTRACTOR'S principal and branch offices other than CONTRACTOR'S office at the site.

10.5.3 Capital Expense

Any part of CONTRACTOR'S capital expenses, including interest on CONTRACTOR'S capital employed for the Work and charges against CONTRACTOR for delinquent payments.

10.5.4 Bonds and Insurance

Cost of premiums for all Bonds and for all insurance whether or not CONTRACTOR is required by the Contract Documents to purchase and maintain the same (except for the cost of premiums covered by subparagraph 10.4.5.9 above).

10.5.5 Costs Due to Negligence

Costs due to the negligence of CONTRACTOR, any Subcontractor, or anyone directly or indirectly employed by any of them or for whose acts any of them may be liable, including but not limited to, the correction of defective Work, disposal of materials or equipment wrongly supplied and making good any damage to property.

10.5.6 Other Costs

Other overhead or general expense costs of any kind and the costs of any item not specifically and expressly included in paragraph 10.4.

10.6 Contractor's Fee

The CONTRACTOR'S Fee allowed to CONTRACTOR for overhead and profit shall be determined as follows:

10.6.1 a mutually acceptable fixed fee; or if none can be agreed upon,

10.6.2 a fee based on the following percentages of the various portions of the Cost of the Work:

10.6.2.1 for costs incurred under paragraphs 10.4.1 and 10.4.2, the CONTRACTOR'S fee shall be fifteen percent;

10.6.2.2 for costs incurred under paragraph 10.4.3, the CONTRACTOR'S fee shall be five percent; and if a subcontract is on the basis of Cost of the Work Plus a fee, the maximum allowable to CONTRACTOR on account of overhead and profit of all Subcontractors shall be fifteen percent;

10.6.2.3 no fee shall be payable on the basis of costs itemized under paragraphs 10.4.4, 10.4.5 and 10.5;

10.6.2.4 the amount of credit to be allowed by CONTRACTOR to OWNER for any such change which results in a net decrease in cost will be the amount of the actual net decrease plus a deduction in CONTRACTOR'S Fee by an amount equal to ten percent of the net decrease; and

10.6.2.5 when both additions and credits are involved in any one change, the adjustment in CONTRACTOR'S fee shall be computed on the basis of the net change in accordance with paragraphs 10.6.2.1 through 10.6.2.4, inclusive.

10.7 Itemized Cost Breakdown

Whenever the cost of any Work is to be determined pursuant to paragraph 10.4 or 10.5, CONTRACTOR will submit in form acceptable to CONSULTANT an itemized cost breakdown together with supporting data.

10.8 Cash Allowances

It is understood that CONTRACTOR has included in the Contract Price all allowances so named in the Contract Documents and shall cause the Work so covered to be done by such Subcontractors or Suppliers and for such sums within the limit of the allowances as may be acceptable to CONSULTANT, CONTRACTOR agrees that:

10.8.1 Materials and Equipment

The allowances include the cost to CONTRACTOR (less any applicable trade discounts) of materials and equipment required by the allowances to be delivered at the site, and all applicable taxes; and

10.8.2 Other Costs

CONTRACTOR'S costs for unloading and handling on the site, labor, installation costs, overhead, profit and other expenses contemplated for the allowances have been included in the Contract Price and not in the allowances. No demand for additional payment on account of any thereof will be valid.

10.8.3 Change Order

Prior to final payment, an appropriate Change Order will be issued as recommended by CONSULTANT to reflect actual amounts due CONTRACTOR on account of Work covered by allowances, and the Contract Price shall be correspondingly adjusted.

10.9 Unit Price Work

10.9.1 General

Where the Contract Documents provide that all or part of the Work is to be Unit Price Work, initially the Contract Price will be deemed to include for all Unit Price Work an amount equal to the sum of the established unit prices for each separately identified item of Unit Price Work times the estimated quantity of each item as indicated in the Agreement. The estimated quantities of items of Unit Price Work are not guaranteed and are solely for the purpose of comparison of Bids and determining an initial Contract Price. Determinations of the actual quantities and classifications of Unit Price Work performed by CONTRACTOR will be made by CONSULTANT in accordance with Paragraph 8.10.

10.9.2 Overhead and Profit

Each unit price will be deemed to include an amount considered by CONTRACTOR to be adequate to cover CONTRACTOR'S overhead and profit for each separately identified item.

10.9.3 Claim for Increase in Unit Price

Where the quantity of any item of Unit Price Work performed by CONTRACTOR differs materially and significantly from the estimated quantity of such item indicated in the Agreement and there is no corresponding adjustment with respect to any other item of Work and if CONTRACTOR believes that CONTRACTOR has incurred additional expense as a result thereof, CONTRACTOR may make a claim for an increase in the Contract Price in accordance with Article 10.

11. CHANGE OF CONTRACT TIME

11.1 Change Order

The Contract Time may only be changed by a Change Order. Any claim for an extension or shortening of the Contract Time shall be based on written notice delivered to CONSULTANT promptly (but in no event later than thirty days) after the occurrence of the event giving rise to the claim and stating the general nature of the claim. Notice of the extent of the claim with supporting data shall be delivered within sixty days after such occurrence (unless CONSULTANT allows an additional period of time to ascertain more accurate data in support of the claim) and shall be accompanied by the claimant's written statement that the adjustment claimed is the entire adjustment to which the claimant has reason to believe it is entitled as a result of the occurrence of said event. All claims for adjustment in the Contract Time shall be determined by CONSULTANT in accordance with paragraph 8.11. No claim for an adjustment in the Contract Time will be valid if not submitted in accordance with the requirements of this paragraph 11.1.

11.2 Justification for Time Extensions

The Contract Time will be extended in an amount equal to time lost due to delays beyond the control of CONTRACTOR if a claim is made therefore as provided in paragraph 11.1. Such delays shall include, but not be limited to, acts or neglect by OWNER or others performing additional work as contemplated by Article 6, or to fires, floods, labor disputes, epidemics, abnormal weather conditions or acts of God.

11.3 Time Limits

All time limits stated in the Contract Documents are of the essence of the Agreement. The provisions of this Article 11 shall not exclude recovery for damages (including but not limited to fees and charges of engineers, architects, attorneys and other professionals and court costs) for delay by either party.

12. WARRANTY AND GUARANTEE; TESTS AND INSPECTIONS; CORRECTION, REMOVAL OR ACCEPTANCE OF DEFECTIVE WORK

12.1 Warranty and Guarantee

CONTRACTOR warrants and guarantees to OWNER and CONSULTANT that all Work will be in accordance with the Contract Documents and will not be defective. All defective Work, whether or not in place, may be rejected, corrected or accepted as provided in this Article 12.

12.2 Access to Work

CONSULTANT and CONSULTANT'S representatives, other representatives of OWNER, testing agencies and governmental agencies with jurisdictional interests will have access to the Work at reasonable times for their observation, inspecting and testing. CONTRACTOR shall provide proper and safe conditions for such access.

12.3 Tests and Inspections

12.3.1 Timely Notice

CONTRACTOR shall give CONSULTANT timely notice of readiness of the Work for all required inspections, tests or approvals.

12.3.2 Requirements and Responsibilities

The CONSULTANT may require such inspection and testing during the course of the Work as he/she deems necessary to ascertain and assure the integrity and acceptable quality of the materials incorporated and the work performed. Inspection presence may be either full-time or intermittent, and neither the presence nor absence at any time of the CONSULTANT or the INSPECTOR shall relieve the CONTRACTOR of sole responsibility for the acceptability and integrity of the Work or any part thereof.

The costs of sampling, testing, and inspection on-site to ascertain acceptability of the Work and materials will be borne by the OWNER except as otherwise provided. The OWNER will select a testing laboratory to perform such sampling and testing. Sampling and/or testing required by the CONTRACTOR or necessitated by failure of Work or materials to meet the above acceptability test shall be at the expense of the CONTRACTOR.

Inspection services may be performed by the employees of the OWNER or by others selected or designated by the OWNER or the CONSULTANT.

Sampling and/or testing required for manufacturing quality and/or process control, for certification that raw mineral materials or manufactured products are the quality specified in the contract, or to assure the acceptability for incorporation into the Work shall be borne by the CONTRACTOR or the material supplier.

Cost for inspection, sampling, testing, and approvals required by the laws or regulations of any public body having competent jurisdiction shall be borne by the CONTRACTOR or the material supplier.

Sampling and testing will be in accord with pertinent codes and regulations and with appropriate standards of the American Society of Testing Materials or other specified standards.

12.3.3 On-Site Construction Test and Other Testing

All inspections, tests or approvals other than those required by Laws or Regulations of any public body having jurisdiction shall be performed by organizations acceptable to OWNER and CONTRACTOR (or by CONSULTANT if so specified).

12.3.4 Covered Work

If any Work (including the work of others) that is to be inspected, tested or approved is covered without written concurrence of CONSULTANT, it must, if requested by CONSULTANT, be uncovered for observation. Such uncovering shall be at CONTRACTOR'S expense unless CONTRACTOR has given CONSULTANT timely notice of CONTRACTOR'S intention to cover the same and CONSULTANT has not acted with reasonable promptness in response to such notice.

12.3.5 CONTRACTOR'S Obligation

Neither observations by CONSULTANT nor inspections, tests or approvals by others shall relieve CONTRACTOR from CONTRACTOR'S obligations to perform the Work in accordance with the Contract Documents.

12.4 OWNER May Stop the Work

If the Work is defective, or CONTRACTOR fails to supply sufficient skilled workers or suitable materials or equipment, or fails to furnish or perform the Work in such a way that the completed Work will conform to the Contract Documents, OWNER may order CONTRACTOR to stop the Work, or any portion thereof, until the cause for such order has been eliminated; however, this right of OWNER to stop the Work shall not give rise to any duty on the part of OWNER to exercise this right for the benefit of CONTRACTOR or any other party.

12.5 Correction or Removal of Defective Work

If required by CONSULTANT, CONTRACTOR shall promptly, as directed, either correct all defective Work, whether or not fabricated, installed or completed, or, if the Work has been rejected by CONSULTANT, remove it from the site and replace it with non-defective Work. CONTRACTOR shall bear all direct, indirect and consequential costs of such correction or removal (including but not limited to fees and charges of engineers, architects, attorneys and other professionals) made necessary thereby.

12.6 One Year Correction Period

If within one year after the date of Completion or such longer period of time as may be prescribed by Laws or Regulations or by the terms of any applicable special guarantee required by the Contract Documents or by any specific provision of the Contract Documents, any Work is found to be defective, CONTRACTOR shall promptly, without cost to OWNER and in accordance with OWNER'S written instructions, either correct such defective Work, or, if it has been rejected by OWNER, remove it from the site and replace it with non-defective Work. If CONTRACTOR does not promptly comply with the terms of such instructions, or in an emergency where delay would cause serious risk of loss or damage, OWNER may have the defective Work corrected or the rejected Work removed and replaced, and all direct, indirect and consequential costs of such removal and replacement

(including but not limited to fees and charges of engineers, architects, attorneys and other professionals) will be paid by CONTRACTOR. In special circumstances where a particular item of equipment is placed in continuous service before Completion of all the Work, the correction period for that item may start to run from an earlier date if so provided in the Specifications or by Change Order.

12.7 Acceptance of Defective Work

If, instead of requiring correction or removal and replacement of defective Work, OWNER prefers to accept it, OWNER may do so. CONTRACTOR shall bear all direct, indirect and consequential costs attributable to OWNER'S evaluation of and determination to accept such defective Work (such costs to be approved by CONSULTANT as to reasonableness and to include but not be limited to fees and charges of engineers, architects, attorneys and other professionals).

12.8 OWNER May Correct Defective Work

If CONTRACTOR fails within a reasonable time after written notice of CONSULTANT to proceed to correct and to correct defective Work or to remove and replace rejected Work as required by CONSULTANT in accordance with paragraph 12.5, or if CONTRACTOR fails to perform the Work in accordance with the Contract Documents, or if CONTRACTOR fails to comply with any other provision of the Contract Documents, OWNER may, after seven days' written notice to CONTRACTOR, correct and remedy any such deficiency. In exercising the rights and remedies under this paragraph OWNER shall proceed expeditiously. To the extent necessary to complete corrective and remedial action, OWNER may exclude CONTRACTOR from all or part of the site, take possession of all or part of the Work, and suspend CONTRACTOR'S services related thereto, take possession of CONTRACTOR'S tools, appliances, construction equipment and machinery at the site and incorporate in the Work all materials and equipment stored at the site or for which OWNER has paid CONTRACTOR but which are stored elsewhere. CONTRACTOR shall allow OWNER, OWNER'S representatives, agents and employees such access to the site as may be necessary to enable OWNER to exercise the rights and remedies under this paragraph. All direct, indirect and consequential costs of OWNER in exercising such rights and remedies will be charged against CONTRACTOR in an amount approved as to reasonableness by CONSULTANT, and a Change Order will be issued incorporating the necessary revisions in the Contract Documents with respect to the Work; and OWNER shall be entitled to an appropriate decrease in the Contract Price. Such direct, indirect and consequential costs will include but not be limited to fees and charges of engineers, architects, attorneys and other professionals, all court costs and all costs of repair and replacement of work of others destroyed or damaged by correction, removal or replacement of CONTRACTOR'S defective Work. CONTRACTOR shall not be allowed an extension of the Contract Time because of any delay in performance of the Work attributable to the exercise by OWNER of OWNER'S rights and remedies hereunder.

13. PAYMENTS TO CONTRACTOR AND COMPLETION

13.1 Schedule of Values

The schedule of values established as provided in paragraph 2.8 will serve as the basis for progress payments and will be incorporated into a form of Application for Payment acceptable to CONSULTANT. Progress payments on account of Unit Price Work will be based on the number of units completed.

13.2 Application for Progress Payment

At least ten days before each progress payment is scheduled (but not more often than once a month), CONTRACTOR shall submit to CONSULTANT for review an Application for Payment filled out and signed by CONTRACTOR covering the Work completed as of the date of the Application and accompanied by such supporting documentation as is required by the Contract Documents. If payment is requested on the basis of materials and equipment not incorporated in the Work but delivered and suitably stored at the site or at another location agreed to in writing, the Application for Payment shall also be accompanied by a bill of sale, invoice or other documentation warranting that OWNER has received the materials and equipment free and clear of all liens, charges, security interests and encumbrances (which are hereinafter in these General Conditions referred to as "Liens") and evidence that the materials and equipment are covered by appropriate property insurance and other arrangements to protect OWNER'S interest therein, all of which will be satisfactory to OWNER. OWNER shall, within thirty (30) calendar days of presentation to him of an approved Application for Payment, pay CONTRACTOR the amount approved by CONSULTANT. Monthly progress payments shall be ninety (90) percent of the sum obtained by applying the respective bid unit prices to the approved estimated quantities of work completed by the Contractor during the preceding month. The remaining ten (10) percent will be held by the Owner, as retainage. At such time as the CONSULTANT deems appropriate - based on the quality of work performed, progress of cleanup, and other pertinent factors - the rate of retainage, or the total amount retained, may be reduced; although, any reduction in retainage, below the ten (10) percent level, is made solely at the CONSULTANT's discretion. All remaining retainage held will be included in the final payment to the Contractor.

13.2.1 Waivers of Mechanic's Lien

With each Application for Payment OWNER may require CONTRACTOR to submit waivers of mechanic's lien from entities lawfully entitled to file a mechanic's lien arising out of the Contract and related to the Work covered by the payment.

13.2.1.1 Requirement for waivers of Mechanic's Lien on Partial Applications for Payment will be determined and communicated at the Preconstruction Conference.

13.2.1.2 Submit partial waivers on each item for amount requested in previous application, after deduction for retainage, on each item.

13.2.1.3 When an application shows completion of an item, submit conditional final or full waivers.

13.2.1.4 Owner reserves the right to designate which entities involved in the Work must submit waivers.

13.2.1.5 Waiver Forms: Submit executed waivers of lien on forms acceptable to Owner.

13.3 CONTRACTOR'S Warranty of Title

CONTRACTOR warrants and guarantees that title to all Work, materials and equipment covered by any Application for Payment, whether incorporated in the Project or not, will pass to OWNER no later than the time of payment free and clear of all Liens.

13.4 Review of Applications for Progress Payment

13.4.1 Submission of Application for Payment

CONSULTANT will, after receipt of each Application for Payment, either indicate in writing a recommendation of payment and present the Application to OWNER, or return the Application to CONTRACTOR indicating in writing CONSULTANT'S reasons for refusing to recommend payment. In the latter case, CONTRACTOR may make the necessary corrections and resubmit the Application.

13.4.2 CONSULTANT'S Recommendation

CONSULTANT may refuse to recommend the whole or any part of any payment, if, in CONSULTANT'S opinion, it would be incorrect to make such representations to OWNER. CONSULTANT may also refuse to recommend any such payment, or, because of subsequently discovered evidence or the results of subsequent inspections or tests, nullify any such payment previously recommended, to such extent as may be necessary in CONSULTANT'S opinion to protect OWNER from loss because:

13.4.2.1 the Work is defective, or completed Work has been damaged requiring correction or replacement;

13.4.2.2 the Contract Price has been reduced by Written Amendment or Change Order;

13.4.2.3 OWNER has been required to correct defective Work or complete Work in accordance with paragraph 12.8; or

13.4.2.4 of CONSULTANT's actual knowledge of the occurrence of any of the events enumerated in paragraphs 14.2.1 through 14.2.9 inclusive.

13.5 Partial Utilization

OWNER at any time may request CONTRACTOR in writing to permit OWNER to use any such part of the Work which OWNER believes to be ready for its intended use and has been completed. If CONTRACTOR agrees, CONTRACTOR will certify to OWNER that said part of the Work is complete and request that a Certificate of Completion be issued for that part of the Work.

13.6 Final Inspection

Upon written notice from CONTRACTOR that the entire Work or an agreed portion thereof is complete, CONSULTANT will make a final inspection with CONTRACTOR and will notify CONTRACTOR in writing of all particulars in which this inspection reveals that the Work is incomplete or defective. CONTRACTOR shall immediately take such measures as are necessary to remedy such deficiencies.

13.7 Final Application for Payment

After CONTRACTOR has completed all such corrections to the satisfaction of CONSULTANT and delivered all maintenance and operating instructions, schedules, guarantees, Bonds, certificates of inspection, marked-up record documents (as provided in paragraph 5.14) and other documents - all as required by the Contract Documents, and after CONSULTANT has indicated that the Work is acceptable (subject to the provisions of paragraph 13.10), CONTRACTOR may make application for final payment following the procedure for progress payments. The final Application for Payment shall be accompanied by all documentation called for in the Contract Documents, together with complete and legally effective releases or waivers (satisfactory to OWNER) of all Liens arising out of or filed in connection with the Work. In lieu thereof and as approved by OWNER, CONTRACTOR may furnish receipts or releases in full; an affidavit of CONTRACTOR that the releases and receipts include all labor, services, material and equipment for which a Lien could be filed, and that all payrolls, material and equipment bills, and other indebtedness connected with the Work for which OWNER or OWNER'S property might in any way be responsible, have been paid or otherwise satisfied; and consent of the surety, if any, to final payment. If any Subcontractor or Supplier fails to

furnish a release or receipt in full, CONTRACTOR may furnish a Bond or other collateral satisfactory to OWNER to indemnify OWNER against any Lien.

13.8 Final Payment and Acceptance

13.8.1 CONSULTANT'S Approval

If, on the basis of CONSULTANT'S observation of the Work during construction and final inspection, and CONSULTANT'S review of the final Application for Payment and accompanying documentation - all as required by the Contract Documents, CONSULTANT is satisfied that the Work has been completed and CONTRACTOR'S other obligations under the Contract Documents have been fulfilled, CONSULTANT will, after receipt of the final Application for Payment, indicate in writing CONSULTANT'S recommendation of payment and present the Application to OWNER for payment. Thereupon CONSULTANT will give written notice to OWNER and CONTRACTOR that the Work is acceptable, subject to the provisions of paragraph 13.10. Otherwise, CONSULTANT will return the Application to CONTRACTOR, indicating in writing the reasons for refusing to recommend final payment, in which case CONTRACTOR shall make the necessary corrections and resubmit the Application.

13.8.2 Delay in Completion of Work

If, through no fault of CONTRACTOR, final completion of the Work is significantly delayed, OWNER shall, upon receipt of CONTRACTOR'S final Application for Payment and recommendation of CONSULTANT, and without terminating the Agreement, make payment of the balance due for that portion of the Work fully completed and accepted. If the remaining balance to be held by OWNER for Work not fully completed or corrected is less than the retainage stipulated in the Agreement, and if Bonds have been furnished as required in paragraph 10 of Part II, Information for Bidders, the written consent of the surety to the payment of the balance due for that portion of the Work fully completed and accepted shall be submitted by CONTRACTOR to CONSULTANT with the Application for such payment. Such payment shall be made under the terms and conditions governing final payment, except that it shall not constitute a waiver of claims.

13.9 CONTRACTOR'S Continuing Obligation

CONTRACTOR'S obligation to perform and complete the Work in accordance with the Contract Documents shall be absolute. Neither recommendation of any progress or final payment by CONSULTANT, nor the issuance of a certificate of Completion, nor any payment by OWNER to CONTRACTOR under the Contract Documents, nor any use or occupancy of the Work or any part thereof by OWNER, nor any act of acceptance by OWNER nor any failure to do so, nor any review and approval of a Shop Drawing or sample submission, nor any correction of defective Work by OWNER will constitute an acceptance of Work not in accordance with the Contract Documents or a release of CONTRACTOR'S obligation to perform the

Work in accordance with the Contract Documents (except as provided in paragraph 13.10).

13.10 Waiver of Claims

The making and acceptance of final payment will constitute:

13.10.1 a waiver of all claims by OWNER against CONTRACTOR, except claims arising from unsettled Liens, from defective Work appearing after final inspection or from failure to comply with the Contract Documents or the terms of any special guarantees specified therein; however, it will not constitute a waiver by OWNER of any rights in respect of CONTRACTOR'S continuing obligations under the Contract Documents; and

13.10.2 a waiver of all claims by CONTRACTOR against OWNER other than those previously made in writing and still unsettled.

14. SUSPENSION OF WORK AND TERMINATION

14.1 OWNER May Suspend Work

OWNER may, at any time and without cause, suspend the Work or any portion thereof for a period of not more than ninety days by notice in writing to CONTRACTOR and CONSULTANT which will fix the date on which Work will be resumed. CONTRACTOR shall resume the Work on the date so fixed. CONTRACTOR shall be allowed an increase in the Contract Price or an extension of the Contract Time, or both, directly attributable to any suspension if CONTRACTOR makes an approved claim therefor as provided in Articles 10 and 11.

14.2 OWNER May Terminate

The OWNER may terminate the Work upon the occurrence of any one or more of the following events:

14.2.1 if CONTRACTOR commences a voluntary case under any chapter of the Bankruptcy Code (Title 11, United States Code), as now or hereafter in effect, or if CONTRACTOR takes any equivalent or similar action by filing a petition or otherwise under any other federal or state law in effect at such time relating to the bankruptcy or insolvency;

14.2.2 if a petition is filed against CONTRACTOR under any chapter of the Bankruptcy Code as now or hereafter in effect at the time of filing, or if a petition is filed seeking any such equivalent or similar relief against CONTRACTOR under any other federal or state law in effect at the time relating to bankruptcy or insolvency;

14.2.3 if CONTRACTOR makes a general assignment for the benefit of creditors;

14.2.4 if a trustee, receiver, custodian or agent of CONTRACTOR is appointed under applicable law or under contract, whose appointment or authority to take charge of property of CONTRACTOR is for the purpose of enforcing a Lien against such property or for the purpose of general administration of such property for the benefit of CONTRACTOR'S creditors;

14.2.5 if CONTRACTOR admits in writing an inability to pay its debts generally as they become due;

14.2.6 if CONTRACTOR persistently fails to perform the Work in accordance with the Contract Documents (including, but not limited to, failure to supply sufficient skilled workers or suitable materials or equipment or failure to adhere to the progress schedule established under paragraph 2.8 as revised from time to time);

14.2.7 if CONTRACTOR disregards Laws or Regulations of any public body having jurisdiction;

14.2.8 if CONTRACTOR disregards the authority of CONSULTANT, or

14.2.9 if CONTRACTOR otherwise violates in any substantial way any provisions of the Contract Documents;

OWNER may, after giving CONTRACTOR (and the surety) seven days' written notice and to the extent permitted by Laws and Regulations, terminate the services of CONTRACTOR, exclude CONTRACTOR from the site and take possession of the Work and of all CONTRACTOR'S tools, appliances, construction equipment and machinery at the site and use the same to the full extent they could be used by CONTRACTOR (without liability to CONTRACTOR for trespass or conversion), incorporate in the Work all materials and equipment stored at the site or for which OWNER has paid CONTRACTOR but which are stored elsewhere, and finish the Work as OWNER may deem expedient. In such case CONTRACTOR shall not be entitled to receive any further payment until the Work is finished. If the unpaid balance of the Contract Price exceeds the direct, indirect and consequential costs of completing the Work (including but not limited to fees and charges of engineers, architects, attorneys and other professionals and court and arbitration costs) such excess will be paid to CONTRACTOR. If such costs exceed such unpaid balance, CONTRACTOR shall pay the difference to OWNER. Such costs incurred by OWNER will be approved as to reasonableness by CONSULTANT and incorporated in a Change Order,

but when exercising any rights or remedies under this paragraph OWNER shall not be required to obtain the lowest price for the Work performed.

14.2.10 If safety violations are observed and brought to the Contractors attention and Contractor fails to take immediate corrective measures any repeat of similar safety violations, Owner will order an immediate termination of contract. Note: it is the Contractor's responsibility to know proper safety measures as they pertain to construction and OSHA.

14.2.11 This contract may be canceled by either party thirty (30) days after delivery by canceling party of written notice of intent to cancel to the other contracting party.

14.2.12 This contract may be canceled by the Lexington-Fayette Urban County Government if it is determined that the Bidder has failed to perform under the terms of this agreement, such cancellation to be effective upon receipt of written notice of cancellation by the Bidder.

14.3 CONTRACTOR'S Services Terminated

Where CONTRACTOR'S services have been so terminated by OWNER, the termination will not affect any rights or remedies of OWNER against CONTRACTOR then existing or which may thereafter accrue. Any retention or payment of moneys due CONTRACTOR by OWNER will not release CONTRACTOR from liability.

14.4 Payment After Termination

Upon seven days' written notice to CONTRACTOR, OWNER may, without cause and without prejudice to any other right or remedy, elect to abandon the Work and terminate the Agreement. In such case, CONTRACTOR shall be paid for all Work executed and any expense sustained plus reasonable termination expenses, which will include, but not be limited to, direct, indirect and consequential costs (including, but not limited to, fees and charges of engineers, architects, attorneys and other professionals and court and arbitration costs).

14.5 CONTRACTOR May Stop Work or Terminate

If, through no act or fault of CONTRACTOR, the Work is suspended for a period of more than ninety days by OWNER or under an order of court or other public authority, or CONSULTANT fails to act on any Application for Payment within sixty days after it is submitted, or OWNER fails for sixty days to pay CONTRACTOR any sum finally determined to be due, then CONTRACTOR may, upon seven days' written notice to OWNER and CONSULTANT, terminate the Agreement and recover from OWNER payment for all Work executed and any expense sustained plus reasonable termination expenses. In addition and in lieu of terminating the Agreement, if CONSULTANT has failed to act on an Application for Payment or OWNER has failed to make any payment as aforesaid, CONTRACTOR may upon seven days' written notice to OWNER and

CONSULTANT stop the Work until payment of all amounts then due. The provisions of this paragraph shall not relieve CONTRACTOR of the obligations under paragraph 5.16 to carry on the Work in accordance with the progress schedule and without delay during disputes and disagreements with OWNER.

15. MISCELLANEOUS

15.1 Claims for Injury or Damage

Should OWNER or CONTRACTOR suffer injury or damage to person or property because of any error, omission or act of the other party or of any of the other party's employees or agents or others for whose acts the other party is legally liable, claim will be made in writing to the other party within a reasonable time of the first observance of such injury or damage. The provisions of this paragraph 15.1 shall not be construed as a substitute for or a waiver of the provisions of any applicable statute of limitations or repose.

15.2 Non-Discrimination in Employment

The CONTRACTOR shall comply with the following requirements prohibiting discrimination:

15.2.1 That no person (as defined in KRS 344.010) shall bid on Lexington-Fayette Urban County Government construction projects, or bid to furnish materials or supplies to the Lexington-Fayette Urban County Government, if, within six months prior to the time of opening of bids, said person shall have been found, by declaratory judgment action in Fayette Circuit Court, to be presently engaging in an unlawful practice, as hereinafter defined. Such declaratory judgment action may be brought by an aggrieved individual or upon an allegation that an effort at conciliation pursuant to KRS 344.200 has been attempted and failed, by the Lexington-Fayette County Human Rights Commission.

15.2.2 That it is an unlawful practice for an employer:

15.2.2.1 to fail or refuse to hire, or to discharge any individual or otherwise to discriminate against an individual, with respect to his compensation, terms, conditions, or privileges of employment, because of such individual's race, color, religion, sex, age, or national origin; or

15.2.2.2 to limit, segregate or classify his employees in any way which would deprive or tend to deprive an individual of employment opportunities or otherwise adversely affect his status as an employee because of such individual's sex, race, color, religion, age, or national origin.

15.2.3 That it is an unlawful practice for an employer, labor organization, or joint-labor management committee controlling apprenticeship or other training or retraining, including on-the-job training programs to discriminate against an individual because of his race, color, religion, sex, age, or national origin in admission to, or employment in, any program established to provide apprenticeship or other training.

15.2.4 That a copy of this Ordinance shall be furnished all suppliers and made a part of all bid specifications.

15.2.5 This Ordinance shall take effect after it is signed, published and recorded, as required by law.

15.3 Temporary Street Closing or Blockage

The CONTRACTOR will notify the CONSULTANT at least 72 hours prior to making any temporary street closing or blockage. This will permit orderly notification to all concerned public agencies. Specific details and restrictions on street closure or blockage are contained in the Special Conditions.

15.4 Percentage of Work Performed by prime CONTRACTOR

The CONTRACTOR shall perform on site, and with its own organization, Work equivalent to at least fifty (50%) percent of the total amount of Work to be performed under the Contract. This percentage may be reduced by a supplemental agreement to this Contract if, during performing the Work, the CONTRACTOR requests a reduction and the CONSULTANT determines that the reduction would be to the advantage of the OWNER.

15.5 Clean-up

Clean-up shall progress, to the greatest degree practicable, throughout the course of the Work. The Work will not be considered as completed, and final payment will not be made, until the right-of-way and all ground occupied or affected by the Contractor in connection with the Work has been cleared of all rubbish, equipment, excess materials, temporary structures, and weeds. Rubbish and all waste materials of whatever nature shall be disposed of, off of the project site, in an acceptable manner. All property, both public and private, which has been damaged in the prosecution of the Work, shall be restored in an acceptable manner. All areas shall be draining, and all drainage ways shall be left unobstructed, and in such a condition that drift will not collect or scour be induced.

15.6 General

The duties and obligations imposed by these General Conditions and the rights and remedies available hereunder to the parties hereto, and, in particular but without limitation, the warranties, guarantees and obligations imposed upon CONTRACTOR by paragraphs 12.1, 12.3.5, 13.3, and 15.2 and all of the rights and remedies available to OWNER and CONSULTANT thereunder, are in addition to, and are not to be construed in any way as a limitation of, any rights and remedies

available to any or all of them which are otherwise imposed or available by Laws or Regulations, by special warranty or guarantee or by other provisions of the Contract Documents, and the provisions of this paragraph will be as effective as if repeated specifically in the Contract Documents in connection with each particular duty, obligation, right and remedy to which they apply. All representations, warranties and guarantees made in the Contract Documents will survive final payment and termination or completion of the Agreement.

15.7 Debris Disposal

For all LFUCG projects any trash, construction demolition debris, yard waste, dirt or debris of any kind that is removed from the project site must be disposed of in accordance with local, state, and federal regulations. The disposal site or facility must be approved in advance by the LFUCG and disposal documentation is required. The Contractor will be responsible for payment of any fines associated with improper disposal of material removed from the project site.

END OF SECTION

PART V

SPECIAL CONDITIONS

INDEX

1. REQUIRED RISK MANAGEMENT PROVISIONS
2. BLASTING
3. DIFFERING SITE CONDITIONS
4. FAILURE TO COMPLETE WORK ON TIME
5. KYTC PRE-QUALIFICATION REQUIRED AT TIME OF BID OPENING
6. KY DIVISION OF WATER/EPA PERMITS
7. SPECIAL UTILITY NOTES
8. PREVAILING WAGE REQUIREMENTS AND LABOR PROVISION – KENTUCKY

1.

**RISK MANAGEMENT PROVISIONS
INSURANCE AND INDEMNIFICATION**

INDEMNIFICATION AND HOLD HARMLESS PROVISION

- (1) It is understood and agreed by the parties that Contractor hereby assumes the entire responsibility and liability for any and all damages to persons or property caused by or resulting from or arising out of any act or omission on the part of Contractor or its employees, agents, servants, owners, principals, licensees, assigns or subcontractors of any tier (hereinafter "CONTRACTOR") under or in connection with this agreement and/or the provision of goods or services and the performance or failure to perform any work required thereby.
- (2) CONTRACTOR shall indemnify, save, hold harmless and defend the Lexington-Fayette Urban County Government and its elected and appointed officials, employees, agents, volunteers, and successors in interest (hereinafter "LFUCG") from and against all liability, damages, and losses, including but not limited to, demands, claims, obligations, causes of action, judgments, penalties, fines, liens, costs, expenses, interest, defense costs and reasonable attorney's fees that are in any way incidental to or connected with, or that arise or are alleged to have arisen, directly or indirectly, from or by CONTRACTOR's performance or breach of the agreement and/or the provision of goods or services provided that: (a) it is attributable to personal injury, bodily injury, sickness, or death, or to injury to or destruction of property (including the loss of use resulting therefrom), or to or from the negligent acts, errors or omissions or willful misconduct of the CONTRACTOR; and (b) not caused solely by the active negligence or willful misconduct of LFUCG.
- (3) In the event LFUCG is alleged to be liable based upon the above, CONTRACTOR shall defend such allegations and shall bear all costs, fees and expenses of such defense, including but not limited to, all reasonable attorneys' fees and expenses, court costs, and expert witness fees and expenses, using attorneys approved in writing by LFUCG, which approval shall not be unreasonably withheld.
- (4) These provisions shall in no way be limited by any financial responsibility or insurance requirements, and shall survive the termination of this agreement.
- (5) LFUCG is a political subdivision of the Commonwealth of Kentucky. CONTRACTOR acknowledges and agrees that LFUCG is unable to provide indemnity or otherwise save, hold harmless, or defend the CONTRACTOR in any manner.

FINANCIAL RESPONSIBILITY

BIDDER/CONTRACTOR understands and agrees that it shall demonstrate the ability to assure compliance with the above Indemnity provisions and these other risk management provisions prior to final acceptance of its bid and the commencement of any work or provision of goods.

INSURANCE REQUIREMENTS

YOUR ATTENTION IS DIRECTED TO THE INSURANCE REQUIREMENTS BELOW, AND YOU MAY NEED TO CONFER WITH YOUR INSURANCE AGENTS, BROKERS, OR CARRIERS TO DETERMINE IN ADVANCE OF SUBMISSION OF A RESPONSE THE AVAILABILITY OF THE INSURANCE COVERAGES AND ENDORSEMENTS REQUIRED HEREIN. IF YOU FAIL TO COMPLY WITH THE INSURANCE REQUIREMENTS BELOW, YOU MAY BE DISQUALIFIED FROM AWARD OF THE CONTRACT.

Required Insurance Coverage

BIDDER/CONTRACTOR shall procure and maintain for the duration of this contract the following or equivalent insurance policies at no less than the limits shown below and cause its subcontractors to maintain similar insurance with limits acceptable to LFUCG in order to protect LFUCG against claims for injuries to persons or damages to property which may arise from or in connection with the performance of the work hereunder by CONTRACTOR. The cost of such insurance shall be included in any bid:

<u>Coverage</u>	<u>Limits</u>
General Liability (Insurance Services Office Form CG 00 01)	\$1 million per occurrence, \$2 million aggregate or \$2 million combined single limit
Commercial Automobile Liability (Insurance Services Office Form CA 0001)	combined single, \$1 million per occurrence
Worker's Compensation	Statutory
Employer's Liability	\$500,000 to \$1,000,000
Umbrella/Excess Liability	\$5 million

The policies above shall contain the following conditions:

- a. All Certificates of Insurance forms used by the insurance carrier shall be properly filed and approved by the Department of Insurance for the Commonwealth of Kentucky (DOI). LFUCG shall be named as an additional insured in the General Liability Policy and Commercial Automobile Liability Policy using the Kentucky DOI approved forms.
- b. The General Liability Policy shall be primary to any insurance or self-insurance retained by LFUCG.
- c. The General Liability Policy shall include Products and Completed Operations coverage and Premises and Operations coverage unless it is deemed not to apply by LFUCG.

- d. LFUCG shall be provided at least 30 days advance written notice via certified mail, return receipt requested, in the event any of the required policies are canceled or non-renewed.
- e. Said coverage shall be written by insurers acceptable to LFUCG and shall be in a form acceptable to LFUCG. Insurance placed with insurers with a rating classification of no less than Excellent (A or A-) and a financial size category of no less than VIII, as defined by the most current Best's Key Rating Guide shall be deemed automatically acceptable.

Renewals

After insurance has been approved by LFUCG, evidence of renewal of an expiring policy must be submitted to LFUCG, and may be submitted on a manually signed renewal endorsement form. If the policy or carrier has changed, however, new evidence of coverage must be submitted in accordance with these Insurance Requirements.

Deductibles and Self-Insured Programs

IF YOU INTEND TO SUBMIT A SELF-INSURANCE PLAN IT MUST BE FORWARDED TO LEXINGTON-FAYETTE URBAN COUNTY GOVERNMENT, DIVISION OF RISK MANAGEMENT, 200 EAST MAIN STREET, LEXINGTON, KENTUCKY 40507 NO LATER THAN A MINIMUM OF FIVE (5) WORKING DAYS PRIOR TO THE RESPONSE DATE. Self-insurance programs, deductibles, and self-insured retentions in insurance policies are subject to separate approval by Lexington-Fayette Urban County Government's Division of Risk Management, upon review of evidence of BIDDER/CONTRACTOR's financial capacity to respond to claims. Any such programs or retentions must provide LFUCG with at least the same protection from liability and defense of suits as would be afforded by first-dollar insurance coverage

Safety and Loss Control

CONTRACTOR shall comply with all applicable federal, state, and local safety standards related to the performance of its works or services under this Agreement and take necessary action to protect the life, health and safety and property of all of its personnel on the job site, the public, and LFUCG.

Verification of Coverage

BIDDER/CONTRACTOR agrees to furnish LFUCG with all applicable Certificates of Insurance signed by a person authorized by the insurer to bind coverage on its behalf prior to final award, and if requested, shall provide LFUCG copies of all insurance policies, including all endorsements.

Right to Review, Audit and Inspect

CONTRACTOR understands and agrees that LFUCG may review, audit and inspect any and all of its records and operations to insure compliance with these Insurance Requirements.

DEFAULT

BIDDER/CONTRACTOR understands and agrees that the failure to comply with any of these insurance, safety, or loss control provisions shall constitute default and that LFUCG may elect at its option any single remedy or penalty or any combination of remedies and penalties, as available, including but not limited to purchasing insurance and charging BIDDER/CONTRACTOR for any such insurance premiums purchased, or suspending or terminating the work.

2. BLASTING

Blasting is NOT allowed on this project.

3. DIFFERING SITE CONDITIONS

As described in Section 4 of the General Conditions, 23 CFR635.109 shall also apply. Refer to Appendix D for Standardized Changed Conditions Clauses.

4. FAILURE TO COMPLETE WORK ON TIME

Should the Contractor fail or refuse to complete the work within the time specified in his Proposal and/or Contract (or extension of time granted by the OWNER), the Contractor shall pay liquidated damages in an amount set out in said Proposal and/or Contract. The amount of liquidated damages shall in no event be considered as a penalty, nor other than an amount agreed upon by the Contractor and the OWNER for damages, losses, additional engineering, additional resident representation and other costs that will be sustained by the OWNER, if the Contractor fails to complete the work within the specified time. Liquidated damages will be applied on a rate per day for each and every calendar day (Sundays and holidays included) beyond the Contract expiration date stipulated in the Contract Documents, considering all time extensions granted.

5. KYTC PRE-QUALIFICATION REQUIRED AT TIME OF BID OPENING

Bidders and DBE subcontractors must be prequalified with the Kentucky Transportation Cabinet and possess a Certificate of Eligibility at the time of bid opening. All other subcontractors must be prequalified when accepting subcontracts.

6. KY DIVISION OF WATER/EPA PERMITS

The Contractor shall apply for and obtain an LFUCG Land Disturbance Permit. If the disturbed area equals or exceeds one (1) acre, the Contractor shall prepare and file the Notice of Intent, the Notice of Termination, and prepare and maintain the BMP (Best Management Practices) and SWPP (Storm Water Pollution Prevention) Plans to obtain coverage under the Kentucky Pollutant Discharge Elimination System (KPDES).

7. SPECIAL UTILITY NOTES

IMPACT ON CONSTRUCTION

GENERAL PROJECT NOTE ON UTILITY PROTECTION

Utility coordination efforts determined that minor utility relocation work is required to complete the project. Any work pertaining to these utility facilities is defined in the bid package and is to be carried out as instructed by the LFUCG. The contractor will be responsible for any coordination or adjustments that are discussed or quantified in the proposal.

The LFUCG Division of Traffic Engineering has fiber optic cable along Man O' War Boulevard. The contractor is to install new junction boxes at each end of the project, between the new curb and the new sidewalk. The contractor will install new conduit between the junction boxes. The installation of the fiber optic cable will be performed by Traffic Engineering.

This project requires the relocation of three street lights. The contractor will install conduit and bases. Kentucky Utilities will install the electrical cable, light poles, and fixtures.

Coordination with LFUCG Division of Traffic Engineering and Kentucky Utilities is required before construction in the area begins.

The contractor is instructed to call 1-800-752-6007 to reach KY 811, the one-call system for information on the location of existing underground utilities. The call is to be placed a minimum of two (2) and no more than ten (10) business days prior to excavation. The contractor should be aware that owners of underground facilities are not required to be members of the KY 811 one-call Before-U-Dig (BUD) service. The contractor must coordinate excavation with the utility owners, including those whom do not subscribe to KY 811. It may be necessary for the contractor to contact the County Court Clerk to determine what utility companies have facilities in the area.

Please Note: The information presented in this Utility Note is informational in nature and the information contained herein is not guaranteed.

Utility Notes continued on following pages

**UTILITY NOTES TO BE INCLUDED IN THE PROPOSAL
IMPACT ON CONSTRUCTION**

FAYETTE COUNTY

Man O' War Boulevard Public Improvement Project Alumni Drive Intersection

Utility coordination efforts determined that all utility relocation will be completed before construction is started. Any information pertaining to utility facilities are defined in the bid package and are to be carried out as instructed by the LFUCG. The contractor will be responsible for any coordination or adjustments that are discussed or quantified in the proposal.

Utility Information Note

Lexington Fayette Urban County Government, Kentucky Utilities, Charter Communications (formerly Time Warner Cable), Columbia Gas, Windstream Communications and Kentucky American Water have service in the vicinity of the construction. LFUCG Division of Traffic Engineering has fiber optic along Man O' War that will be impacted. Three street lights maintained by Kentucky Utilities will be impacted.

SPECIAL CAUTION NOTE – PROTECTION OF UTILITIES

The contractor will be responsible for contacting all utility facility owners on the subject project to coordinate his activities. The contractor will coordinate his activities to minimize and, where possible, avoid conflicts with utility facilities. Due to the nature of the work proposed, it is unlikely to conflict with the existing utilities beyond minor facility adjustments. Where conflicts with utility facilities are unavoidable, the contractor will coordinate any necessary relocation work with the facility owner and Resident Engineer. The Lexington-Fayette Urban County Government maintains the right to remove or alter portions of this contract if a utility conflict occurs.

The Lexington-Fayette Urban County Government makes no guarantees regarding: the existence of utilities, the location of utilities, the utility companies in the project scope, or the potential for conflicts encountered during construction. Any location of utilities provided herein has been furnished by the facility owners, field inspection, and/or reviewing record drawings. The accuracy of the information provided is undetermined. It will be the contractor's responsibility to locate utilities before excavating. If necessary, the roadway contractor shall determine the exact location and elevation of utilities by hand digging to expose utilities before excavating in the area of a utility.

The contractor is advised to contact KY 811 one-call system; however, the contractor should be aware that owners of underground facilities are not required to be members of the KY 811 one-call system. It may be necessary for the contractor to contact the County Court Clerk to determine what utility companies have facilities in the project area. Note: See attached sheet for Project Area Utility Contacts.

UTILITY CONTACT LIST FOR PROJECT AREA

It has not been confirmed what specific utility is located within the project bounds beyond field inspection. Therefore, we have provided a contact list as a precautionary measure to aid the awarded contractor in contacting any utility necessary.

Kentucky Utilities Company
500 Stone Road
Lexington, KY 40503

Contact: Kevin Long
859-367-4306
Kevin.Long@lge-ku.com

Charter Communications
2544 Palumbo Drive
Lexington, KY 40509

Contact: John Oram
859-514-2503
john.oram@charter.com

Windstream Communications, Inc.
130 West New Circle Road, Suite 170
Lexington, KY 40505

Contact: Steve Johnson
859-357-6215
Steve.Johnson@windstream.com

Kentucky American Water
2300 Richmond Road
Lexington, KY 40502

Contact: Cole Mitcham
859-335-3415
cole.mitcham@amwater.com

Columbia Gas of Kentucky, Inc.
2001 Mercer Road
P.O. Box 14241
Lexington, KY 40512

Contact: David Lemons
859-288-0249
dnlemons@misource.com

LFUCG Division of Water Quality
301 Lisle Industrial Avenue
Lexington, KY 40511

Contact: Rodney Chervus, P.E.
859-425-2400
rchervus@lexingtonky.com

LFUCG Traffic Engineering
101 E. Vine Street, Suite 300
Lexington, KY 40507

Contact: Jeffrey Neal
859-258-3830
jneal@lexingtonky.com

Lexington-Fayette Urban County Government
Storm Sewers
101 E. Vine Street, Suite 300
Lexington, KY 40507

Contact: Thomas Clements
859-258-3830
tclements@lexingtonky.com

AIRPORT CONTACTS - None within project corridor.

RAILROAD COMPANIES - None within project corridor.

**8. PREVAILING WAGE REQUIREMENTS AND LABOR PROVISION -
KENTUCKY**

**SPECIAL CONDITIONS
LABOR/EQUAL EMPLOYMENT OPPORTUNITY
INFORMATION PACKAGE**

**FOR
LEXINGTON-FAYETTE URBAN COUNTY GOVERNMENT**

JIM GRAY, MAYOR

LABOR/EEO CONDITIONS INDEX

PROJECT NAME: _____

BID NO. _____

ITEM DESCRIPTION

- REQUIRED CONTRACT PROVISIONS FORM FHWA-1273
- COMPLIANCE WITH EXECUTIVE ORDER 11246
- NOTICE OF REQUIREMENT FOR AFFIRMATIVE ACTION TO ENSURE EQUAL OPPORTUNITY (EXECUTIVE ORDER 11246)
- REPORTING REQUIREMENTS
- PATENT RIGHT REQUIREMENTS
- COPYRIGHT REQUIREMENTS
- ACCESS TO RECORDS REQUIREMENTS AND RECORD RETENTION REQUIREMENTS
- CONTRACT AWARD RESTRICTIONS TO FOREIGN COUNTRIES
- KENTUCKY EQUAL EMPLOYMENT OPPORTUNITY ACT
- OTHER FEDERAL REQUIREMENTS
- PUBLIC LAW 88-352: TITLE VI OF THE CIVIL RIGHTS ACT OF 1964
- COMPLIANCE WITH CLEAN AIR AND WATER ACTS
- ENERGY EFFICIENCY REQUIREMENTS
- LEAD-BASED PAINT CONSIDERATIONS
- POTENTIAL DBE CONTRACTOR'S LIST CONTACT
- EQUAL EMPLOYMENT OPPORTUNITY AFFIRMATIVE ACTION
- DEBARMENT CERTIFICATION (TO BE COMPLETED AND/OR SIGNED)
- FEDERAL WAGE SCALE

FORM FHWA-1273

REQUIRED CONTRACT PROVISIONS FEDERAL - AID CONSTRUCTION
CONTRACTS

- I. General
- II. Nondiscrimination
- III. Nonsegregated Facilities
- IV. Payment of Predetermined Minimum Wage
- V. Statements and Payrolls
- VI. Record of Materials, Supplies, and Labor
- VII. Subletting or Assigning the Contract
- VIII. Safety: Accident Prevention
- IX. False Statements Concerning Highway Project
- X. Implementation of Clean Air Act and Federal Water Pollution Control Act
- XI. Certification Regarding Debarment, Suspension, Ineligibility, and Voluntary
Exclusion
- XII. Certification Regarding Use of Contract Funds for lobbying

ATTACHMENTS

- A. Employment Preference for Appalachian Contracts (included in Appalachian contracts only)

I. GENERAL

- 1. These contract provisions shall apply to all work performed on the contract by the contractor's own organization and with the assistance of workers under the contractor's immediate superintendent and to all work performed on the contract by piecework, station work, or by subcontract.
- 2. Except as otherwise provided for in each section, the contractor shall insert in each subcontract all of the stipulations contained in these Required Contract Provisions, and further require their inclusion in any lower tier subcontract or purchase order that may in turn be made. The Required Contract Provisions shall not be incorporated by reference in any case. The prime contractor shall be responsible for compliance by any subcontractor or lower tier subcontractor with these Required Contract Provisions.
- 3. A breach of any of the stipulations contained in these Required Contract Provisions shall be sufficient grounds for termination of the contract.
- 4. A breach of the following clauses of the Required Contract Provisions may also be grounds for debarment as provided in 29 CFR 5.12:
 - Section I, paragraph 2;
 - Section IV, paragraphs 1, 2, 3, 4, and 7;
 - Section V, paragraphs 1 and 2a through 2g.

5. Disputes arising out of the labor standards provisions of Section IV (except paragraph 5) and Section V of these Required Contract Provisions shall not be subject to the general disputes clause of this contract. Such disputes shall be resolved in accordance with the procedures of the U.S. Department of Labor (DOL) as set forth in 29 CFR 5, 6, and 7. Disputes within the meaning of this clause include disputes between the contractor (or any of its subcontractors) and the contracting agency, the DOL, or the contractor's employees or their representatives.

6. **Selection of Labor:** During the performance of this contract, the contractor shall not:
- a. discriminate against labor from any other State, possession, or territory of the United States (except for employment preference for Appalachian contracts, when applicable, as specified in Attachment A), or
 - b. employ convict labor for any purpose within the limits of the project unless it is labor performed by convicts who are on parole, supervised release, or probation.

II. NONDISCRIMINATION

(Applicable to all Federal-aid construction contracts and to all related subcontracts of \$10,000 or more.)

1. **Equal Employment Opportunity:** Equal employment opportunity (EEO) requirements not to discriminate and to take affirmative action to assure equal opportunity as set forth under laws, executive orders, rules, regulations (28 CFR 35, 29 CFR 1630 and 41 CFR 60) and orders of the Secretary of Labor as modified by the provisions prescribed herein, and imposed pursuant to 23 U.S.C. 140 shall constitute the EEO and specific affirmative action standards for the contractor's project activities under this contract. The Equal Opportunity Construction Contract Specifications set forth under 41 CFR 60-4.3 and the provisions of the American Disabilities Act of 1990 (42 U.S.C. 12101 et seq.) set forth under 28 CFR 35 and 29 CFR 1630 are incorporated by reference in this contract. In the execution of this contract, the contractor agrees to comply with the following minimum specific requirement activities of EEO:

- a. The contractor will work with the State highway agency (SHA) and the Federal Government in carrying out EEO obligations and in their review of his/her activities under the contract.
- b. The contractor will accept as his operating policy the following statement:
"It is the policy of this Company to assure that applicants are employed, and that employees are treated during employment, without regard to their race, religion, sex, color, national origin, age or disability. Such action shall include: employment, upgrading, demotion, or transfer; recruitment or recruitment advertising; layoff or termination; rates of pay or other forms of compensation; and selection for training, including apprenticeship, pre-apprenticeship, and/or on-the-job training."

2. **EEO Officer:** The contractor will designate and make known to the SHA contracting officers an EEO Officer who will have the responsibility for and must be capable of effectively administering and promoting an active contractor program of EEO and who must be assigned adequate authority and responsibility to do so.

3. Dissemination of Policy: All members of the contractor's staff who are to hire, supervise, promote, and discharge employees, or who recommend such action, or who are substantially involved in such action, will be made fully cognizant of, and will implement, the contractor's EEO policy and contractual will be taken as a minimum:

- a. Periodic meetings of supervisory and personnel office employees will be conducted before the start of work and then not less often than once every six months, at which time the contractor's EEO policy and its implementation will be reviewed and explained. The meetings will be conducted by the EEO Officer.
- b. All new supervisory or personnel office employees will be given a thorough indoctrination by the EEO Officer, covering all major aspects of the contractor's EEO obligations within thirty days following their reporting for duty with the contractor.
- c. All personnel who are engaged in direct recruitment for the project will be instructed by the EEO Officer in the contractor's procedures for locating and hiring minority group employees.
- d. Notices and posters setting forth the contractor's EEO policy will be placed in areas readily accessible to employees, applicants for employment and potential employees.
- e. The contractor's EEO policy and the procedures to implement such policy will be brought to the attention of employees by means of meetings, employee handbooks, or other appropriate means.

4. Recruitment: When advertising for employees, the contractor will include in all advertisements for employees the notation: "An Equal Opportunity Employer." All such advertisements will be placed in publications having a large circulation among minority groups in the area from which the project work force would normally be derived.

- a. The contractor will, unless precluded by a valid bargaining agreement, conduct systematic and direct recruitment through public and private employee referral sources likely to yield qualified minority group applicants. To meet this requirement, the contractor will identify sources of potential minority group employees, and establish with such identified sources procedures whereby minority group applicants may be referred to the contractor for employment consideration.
- b. In the event the contractor has a valid bargaining agreement providing for exclusive hiring hall referrals, he is expected to observe the provisions of that agreement to the extent that the system permits the contractor's compliance with EEO contract provisions. (The DOL has held that where implementation of such agreements have the effect of discriminating against minorities or women, or obligates the contractor to do the same, such implementation violates Executive Order 11246, as amended.)
- c. The contractor will encourage his present employees to refer minority group applicants for employment. Information and procedures with regard to referring minority group applicants will be discussed with employees.

5. Personnel Actions: Wages, working conditions, and employee benefits shall be established and administered, and personnel actions of every type, including hiring, upgrading, promotion, transfer, demotion, layoff, and termination, shall be taken without

regard to race, color, religion, sex, national origin, age or disability. The following procedures shall be followed:

- a. The contractor will conduct periodic inspections of project sites to insure that working conditions and employee facilities do not indicate discriminatory treatment of project site personnel.
- b. The contractor will periodically evaluate the spread of wages paid within each classification to determine any evidence of discriminatory wage practices.
- c. The contractor will periodically review selected personnel actions in depth to determine whether there is evidence of discrimination. Where evidence is found, the contractor will promptly take corrective action. If the review indicates that the discrimination may extend beyond the actions reviewed, such corrective action shall include all affected persons.
- d. The contractor will promptly investigate all complaints of alleged discrimination made to the contractor in connection with his obligations under this contract, will attempt to resolve such complaints, and will take appropriate corrective action within a reasonable time. If the investigation indicates that the discrimination may affect persons other than the complainant, such corrective action shall include such other persons. Upon completion of each investigation, the contractor will inform every complainant of all of his avenues of appeal.

6. Training and Promotion:

- a. The contractor will assist in locating, qualifying, and increasing the skills of minority group and women employees, and applicants for employment.
- b. Consistent with the contractor's work force requirements and as permissible under Federal and State regulations, the contractor shall make full use of training programs, i.e., apprenticeship, and on-the-job training programs for the geographical area of contract performance. Where feasible, 25 percent of apprentices or trainees in each occupation shall be in their first year of apprenticeship or training. In the event a special provision for training is provided under this contract, this subparagraph will be superseded as indicated in the special provision.
- c. The contractor will advise employees and applicants for employment of available training programs and entrance requirements for each.
- d. The contractor will periodically review the training and promotion potential of minority group and women employees and will encourage eligible employees to apply for such training and promotion.

7. Unions: If the contractor relies in whole or in part upon unions as a source of employees, the contractor will use his/her best efforts to obtain the cooperation of such unions to increase opportunities for minority groups and women within the unions, and to effect referrals by such unions of minority and female employees. Actions by the contractor either directly or through a contractor's association acting as agent will include the procedures set forth below:

- a. The contractor will use best efforts to develop, in cooperation with the unions, joint training programs aimed toward qualifying more minority group members and women for membership in the unions and increasing the skills of minority group employees and women so that they may qualify for higher paying employment.

- b. The contractor will use best efforts to incorporate an EEO clause into each union agreement to the end that such union will be contractually bound to refer applicants without regard to their race, color, religion, sex, national origin, age or disability.
- c. The contractor is to obtain information as to the referral practices and policies of the labor union except that to the extent such information is within the exclusive possession of the labor union and such labor union refuses to furnish such information to the contractor, the contractor shall so certify to the SHA and shall set forth what efforts have been made to obtain such information.
- d. In the event the union is unable to provide the contractor with a reasonable flow of minority and women referrals within the time limit set forth in the collective bargaining agreement, the contractor will, through independent recruitment efforts, fill the employment vacancies without regard to race, color, religion, sex, national origin, age or disability; making full efforts to obtain qualified and/or qualifiable minority group persons and women. (The DOL has held that it shall be no excuse that the union with which the contractor has a collective bargaining agreement providing for exclusive referral failed to refer minority employees.) In the event the union referral practice prevents the contractor from meeting the obligations pursuant to Executive Order 11246, as amended, and these special provisions, such contractor shall immediately notify the SHA.

8. Selection of Subcontractors, Procurement of Materials and Leasing of Equipment:

The contractor shall not discriminate on the grounds of race, color, religion, sex, national origin, age or disability in the selection and retention of subcontractors, including procurement of materials and leases of equipment.

- a. The contractor shall notify all potential subcontractors and suppliers of his/her EEO obligations under this contract.
- b. Disadvantaged business enterprises (DBE), as defined in 49 CFR 23, shall have equal opportunity to compete for and perform subcontracts which the contractor enters into pursuant to this contract. The contractor will use his best efforts to solicit bids from and to utilize DBE subcontractors or subcontractors with meaningful minority group and female representation among their employees. Contractors shall obtain lists of DBE construction firms from SHA personnel.
- c. The contractor will use his best efforts to ensure subcontractor compliance with their EEO obligations.

9. Records and Reports: The contractor shall keep such records as necessary to document compliance with the EEO requirements. Such records shall be retained for a period of three years following completion of the contract work and shall be available at reasonable times and places for inspection by authorized representatives of the SHA and the FHWA.

- a. The records kept by the contractor shall document the following:
 - 1. The number of minority and non-minority group members and women employed in each work classification on the project;
 - 2. The progress and efforts being made in cooperation with unions, when applicable, to increase employment opportunities for minorities and women;
 - 3. The progress and efforts being made in locating, hiring, training, qualifying, and upgrading minority and female employees; and

4. The progress and efforts being made in securing the services of DBE subcontractors or subcontractors with meaningful minority and female representation among their employees.
- b. The contractors will submit an annual report to the SHA each July for the duration of the project, indicating the number of minority, women, and non-minority group employees currently engaged in each work classification required by the contract work. This information is to be reported on Form FHWA-1391. If on-the job training is being required by special provision, the contractor will be required to collect and report training data.

III. NONSEGREGATED FACILITIES

(Applicable to all Federal-aid construction contracts and to all related subcontracts of \$10,000 or more.)

- a. By submission of this bid, the execution of this contract or subcontract, or the consummation of this material supply agreement or purchase order, as appropriate, the bidder, Federal-aid construction contractor, subcontractor, material supplier, or vendor, as appropriate, certifies that the firm does not maintain or provide for its employees any segregated facilities at any of its establishments, and that the firm does not permit its employees to perform their services at any location, under its control, where segregated facilities are maintained. The firm agrees that a breach of this certification is a violation of the EEO provisions of this contract. The firm further certifies that no employee will be denied access to adequate facilities on the basis of sex or disability.
- b. As used in this certification, the term "segregated facilities" means any waiting rooms, work areas, restrooms and washrooms, restaurants and other eating areas, timeclocks, locker rooms, and other storage or dressing areas, parking lots, drinking fountains, recreation or entertainment areas, transportation, and housing facilities provided for employees which are segregated by explicit directive, or are, in fact, segregated on the basis of race, color, religion, national origin, age or disability, because of habit, local custom, or otherwise. The only exception will be for the disabled when the demands for accessibility override (e.g. disabled parking).
- c. The contractor agrees that it has obtained or will obtain identical certification from proposed subcontractors or material suppliers prior to award of subcontracts or consummation of material supply agreements of \$10,000 or more and that it will retain such certifications in its files.

IV. PAYMENT OF PREDETERMINED MINIMUM WAGE

(Applicable to all Federal-aid construction contracts exceeding \$2,000 and to all related subcontracts, except for projects located on roadways classified as local roads or rural minor collectors, which are exempt.)

1. General:

- a. All mechanics and laborers employed or working upon the site of the work will be paid unconditionally and not less often than once a week and without subsequent

deduction or rebate on any account [except such payroll deductions as are permitted by regulations (29 CFR 3) issued by the Secretary of Labor under the Copeland Act (40 U.S.C. 276c)] the full amounts of wages and bona fide fringe benefits (or cash equivalents thereof) due at time of payment. The payment shall be computed at wage rates not less than those contained in the wage determination of the Secretary of Labor (hereinafter "the wage determination") which is attached hereto and made a part hereof, regardless of any contractual relationship which may be alleged to exist between the contractor or its subcontractors and such laborers and mechanics. The wage determination (including any additional classifications and wage rates conformed under paragraph 2 of this Section IV and the DOL poster (WH-1321) or Form FHWA-1495) shall be posted at all times by the contractor and its subcontractors at the site of the work in a prominent and accessible place where it can be easily seen by the workers. For the purpose of this Section, contributions made or costs reasonably anticipated for bona fide fringe benefits under Section 1(b)(2) of the Davis-Bacon Act (40 U.S.C. 276a) on behalf of laborers or mechanics are considered wages paid to such laborers or mechanics, subject to the provisions of Section IV, paragraph 3b, hereof. Also, for the purpose of this Section, regular contributions made or costs incurred for more than a weekly period (but not less often than quarterly) under plans, funds, or programs, which cover the particular weekly period, are deemed to be constructively made or incurred during such weekly period. Such laborers and mechanics shall be paid the appropriate wage rate and fringe benefits on the wage determination for the classification of work actually performed, without regard to skill, except as provided in paragraphs 4 and 5 of this Section IV.

- b. Laborers or mechanics performing work in more than one classification may be compensated at the rate specified for each classification for the time actually worked therein, provided, that the employer's payroll records accurately set forth the time spent in each classification in which work is performed.
- c. All rulings and interpretations of the Davis-Bacon Act and related acts contained in 29 CFR 1, 3, and 5 are herein incorporated by reference in this contract.

2. Classification:

- a. The SHA contracting officer shall require that any class of laborers or mechanics employed under the contract, which is not listed in the wage determination, shall be classified in conformance with the wage determination.
- b. The contracting officer shall approve an additional classification, wage rate and fringe benefits only when the following criteria have been met:
 - 1. the work to be performed by the additional classification requested is not performed by a classification in the wage determination;
 - 2. the additional classification is utilized in the area by the construction industry;
 - 3. the proposed wage rate, including any bona fide fringe benefits, bears a reasonable relationship to the wage rates contained in the wage determination; and
 - 4. with respect to helpers, when such a classification prevails in the area in which the work is performed.

- c. If the contractor or subcontractors, as appropriate, the laborers and mechanics (if known) to be employed in the additional classification or their representatives, and the contracting officer agree on the classification and wage rate (including the amount designated for fringe benefits where appropriate), a report of the action taken shall be sent by the contracting officer to the DOL, Administrator of the Wage and Hour Division, Employment Standards Administration, Washington, D.C. 20210. The Wage and Hour Administrator, or an authorized representative, will approve, modify, or disapprove every additional classification action within 30 days of receipt and so advise the contracting officer or will notify the contracting officer within the 30-day period that additional time is necessary.
- d. In the event the contractor or subcontractors, as appropriate, the laborers or mechanics to be employed in the additional classification or their representatives, and the contracting officer do not agree on the proposed classification and wage rate (including the amount designated for fringe benefits, where appropriate), the contracting officer shall refer the questions, including the views of all interested parties and the recommendation of the contracting officer, to the Wage and Hour Administrator for determination. Said Administrator, or an authorized representative, will issue a determination within 30 days of receipt and so advise the contracting officer or will notify the contracting officer within the 30-day period that additional time is necessary.
- e. The wage rate (including fringe benefits where appropriate) determined pursuant to paragraph 2c or 2d of this Section IV shall be paid to all workers performing work in the additional classification from the first day on which work is performed in the classification.

3. Payment of Fringe Benefits:

- a. Whenever the minimum wage rate prescribed in the contract for a class of laborers or mechanics includes a fringe benefit which is not expressed as an hourly rate, the contractor or subcontractors, as appropriate, shall either pay the benefit as stated in the wage determination or shall pay another bona fide fringe benefit or an hourly case equivalent thereof.
- b. If the contractor or subcontractor, as appropriate, does not make payments to a trustee or other third person, he/she may consider as a part of the wages of any laborer or mechanic the amount of any costs reasonably anticipated in providing bona fide fringe benefits under a plan or program, provided, that the Secretary of Labor has found, upon the written request of the contractor, that the applicable standards of the Davis-Bacon Act have been met. The Secretary of Labor may require the contractor to set aside in a separate account assets for the meeting of obligations under the plan or program.

4. Apprentices and Trainees (Programs of U.S. DOL) and Helpers:

a. Apprentices:

1. Apprentices will be permitted to work at less than the predetermined rate for the work they performed when they are employed pursuant to and individually registered in a bona fide apprenticeship program registered with the DOL, Employment and Training Administration, Bureau of

Apprenticeship and Training, or with a State apprenticeship agency recognized by the Bureau, or if a person is employed in his/her first 90 days of probationary employment as an apprentice in such an apprenticeship program, who is not individually registered in the program, but who has been certified by the Bureau of Apprenticeship and Training or a State apprenticeship agency (where appropriate) to be eligible for probationary employment as an apprentice.

2. The allowable ratio of apprentices to journeyman-level employees on the job site in any craft classification shall not be greater than the ratio permitted to the contractor as to the entire work force under the registered program. Any employee listed on a payroll at an apprentice wage rate, who is not registered or otherwise employed as stated above, shall be paid not less than the applicable wage rate listed in the wage determination for the classification of work actually performed. In addition, any apprentice performing work on the job site in excess of the ratio permitted under the registered program shall be paid not less than the applicable wage rate on the wage determination for the work actually performed. Where a contractor or subcontractor is performing construction on a project in a locality other than that in which its program is registered, the ratios and wage rates (expressed in percentages of the journeyman-level hourly rate) specified in the contractor's or subcontractor's registered program shall be observed.
 3. Every apprentice must be paid at not less than the rate specified in the registered program for the apprentice's level of progress, expressed as a percentage of the journeyman-level hourly rate specified in the applicable wage determination. Apprentices shall be paid fringe benefits in accordance with the provisions of the apprenticeship program. If the apprenticeship program does not specify fringe benefits, apprentices must be paid the full amount of fringe benefits listed on the wage determination for the applicable classification. If the Administrator for the Wage and Hour Division determines that a different practice prevails for the applicable apprentice classification, fringes shall be paid in accordance with that determination.
 4. In the event the Bureau of Apprenticeship and Training, or a State apprenticeship agency recognized by the Bureau, withdraws approval of an apprenticeship program, the contractor or subcontractor will no longer be permitted to utilize apprentices at less than the applicable predetermined rate for the comparable work performed by regular employees until an acceptable program is approved.
- b. Trainees:
1. Except as provided in 29 CFR 5.16, trainees will not be permitted to work at less than the predetermined rate for the work performed unless they are employed pursuant to and individually registered in a program which has received prior approval, evidenced by formal certification by the DOL, Employment and Training Administration.

2. The ratio of trainees to journeyman-level employees on the job site shall not be greater than permitted under the plan approved by the Employment and Training Administration. Any employee listed on the payroll at a trainee rate who is not registered and participating in a training plan approved by the Employment and Training Administration shall be paid not less than the applicable wage rate on the wage determination for the classification of work actually performed. In addition, any trainee performing work on the job site in excess of the ratio permitted under the registered program shall be paid not less than the applicable wage rate on the wage determination for the work actually performed.
3. Every trainee must be paid at not less than the rate specified in the approved program for his/her level of progress, expressed as a percentage of the journeyman-level hourly rate specified in the applicable wage determination. Trainees shall be paid fringe benefits in accordance with the provisions of the trainee program. If the trainee program does not mention fringe benefits, trainees shall be paid the full amount of fringe benefits listed on the wage determination unless the Administrator of the Wage and Hour Division determines that there is an apprenticeship program associated with the corresponding journeyman-level wage rate on the wage determination which provides for less than full fringe benefits for apprentices, in which case such trainees shall receive the same fringe benefits as apprentices.
4. In the event the Employment and Training Administration withdraws approval of a training program, the contractor or subcontractor will no longer be permitted to utilize trainees at less than the applicable predetermined rate for the work performed until an acceptable program is approved.

c. **Helpers:**

Helpers will be permitted to work on a project if the helper classification is specified and defined on the applicable wage determination or is approved pursuant to the conformance procedure set forth in Section IV.2. Any worker listed on a payroll at a helper wage rate, who is not a helper under an approved definition, shall be paid not less than the applicable wage rate on the wage determination for the classification of work actually performed.

5. Apprentices and Trainees (Programs of the U.S. DOT):

Apprentices and trainees working under apprenticeship and skill training programs which have been certified by the Secretary of Transportation as promoting EEO in connection with Federal-aid highway construction programs are not subject to the requirements of paragraph 4 of this Section IV. The straight time hourly wage rates for apprentices and trainees under such programs will be established by the particular programs. The ratio of apprentices and trainees to journeymen shall not be greater than permitted by the terms of the particular program.

6. Withholding:

The SHA shall upon its own action or upon written request of an authorized representative of the DOL withhold, or cause to be withheld, from the contractor or

subcontractor under this contract or any other Federal contract with the same prime contractor, or any other Federally-assisted contract subject to Davis-Bacon prevailing wage requirements which is held by the same prime contractor, as much of the accrued payments or advances as may be considered necessary to pay laborers and mechanics, including apprentices, trainees, and helpers, employed by the contractor or any subcontractor the full amount of wages required by the contract. In the event of failure to pay any laborer or mechanic, including any apprentice, trainee, or helper, employed or working on the site of the work, all or part of the wages required by the contract, the SHA contracting officer may, after written notice to the contractor, take such action as may be necessary to cause the suspension of any further payment, advance, or guarantee of funds until such violations have ceased.

7. Overtime Requirements:

No contractor or subcontractor contracting for any part of the contract work which may require or involve the employment of laborers, mechanics, watchmen, or guards (including apprentices, trainees, and helpers described in paragraphs 4 and 5 above) shall require or permit any laborer, mechanic, watchman, or guard in any workweek in which he/she is employed on such work, to work in excess of 40 hours in such workweek unless such laborer, mechanic, watchman, or guard receives compensation at a rate not less than one-and-one-half times his/her basic rate of pay for all hours worked in excess of 40 hours in such workweek.

8. Violation:

Liability for Unpaid Wages; Liquidated Damages: In the event of any violation of the clause set forth in paragraph 7 above, the contractor and any subcontractor responsible thereof shall be liable to the affected employee for his/her unpaid wages. In addition, such contractor and subcontractor shall be liable to the United States (in the case of work done under contract for the District of Columbia or a territory, to such District or to such territory) for liquidated damages. Such liquidated damages shall be computed with respect to each individual laborer, mechanic, watchman, or guard employed in violation of the clause set forth in paragraph 7, in the sum of \$10 for each calendar day on which such employee was required or permitted to work in excess of the standard work week of 40 hours without payment of the overtime wages required by the clause set forth in paragraph 7.

9. Withholding for Unpaid Wages and Liquidated Damages:

The SHA shall upon its own action or upon written request of any authorized representative of the DOL withhold, or cause to be withheld, from any monies payable on account of work performed by the contractor or subcontractor under any such contract or any other Federal contract with the same prime contractor, or any other Federally-assisted contract subject to the Contract Work Hours and Safety Standards Act, which is held by the same prime contractor, such sums as may be determined to be necessary to satisfy any liabilities of such contractor or subcontractor for unpaid wages and liquidated damages as provided in the clause set forth in paragraph 8 above.

V. STATEMENTS AND PAYROLLS

(Applicable to all Federal-aid construction contracts exceeding \$2,000 and to all related subcontracts, except for projects located on roadways classified as local roads or rural collectors, which are exempt.)

1. Compliance with Copeland Regulations (29 CFR 3):

The contractor shall comply with the Copeland Regulations of the Secretary of Labor which are herein incorporated by reference.

2. Payrolls and Payroll Records:

- a. Payrolls and basic records relating thereto shall be maintained by the contractor and each subcontractor during the course of the work and preserved for a period of 3 years from the date of completion of the contract for all laborers, mechanics, apprentices, trainees, watchmen, helpers, and guards working at the site of the work.
- b. The payroll records shall contain the name, social security number, and address of each such employee; his or her correct classification; hourly rates of wages paid (including rates of contributions or costs anticipated for bona fide fringe benefits or cash equivalent thereof the types described in Section 1(b)(2)(B) of the Davis Bacon Act); daily and weekly number of hours worked; deductions made; and actual wages paid. In addition, for Appalachian contracts, the payroll records shall contain a notation indicating whether the employee does, or does not, normally reside in the labor area as defined in Attachment A, paragraph 1. Whenever the Secretary of Labor, pursuant to Section IV, paragraph 3b, has found that the wages of any laborer or mechanic include the amount of any costs reasonably anticipated in providing benefits under a plan or program described in Section 1(b)(2)(B) of the Davis Bacon Act, the contractor and each subcontractor shall maintain records which show that the commitment to provide such benefits is enforceable, that the plan or program is financially responsible, that the plan or program has been communicated in writing to the laborers or mechanics affected, and show the cost anticipated or the actual cost incurred in providing benefits. Contractors or subcontractors employing apprentices or trainees under approved programs shall maintain written evidence of the registration of apprentices and trainees, and ratios and wage rates prescribed in the applicable programs.
- c. Each contractor and subcontractor shall furnish, each week in which any contract work is performed, to the SHA resident engineer a payroll of wages paid each of its employees (including apprentices, trainees, and helpers, described in Section IV, paragraphs 4 and 5, and watchmen and guards engaged on work during the preceding weekly payroll period). The payroll submitted shall set out accurately and completely all of the information required to be maintained under paragraph 2b of this Section V. This information may be submitted in any form desired. Optional Form WH-347 is available for this purpose and may be purchased from the Superintendent of Documents (Federal stock number 029-005-0014-1), U.S. Government Printing Office, Washington, D.C. 20402. The prime contractor is responsible for the submission of copies of payrolls by all subcontractors.

- d. Each payroll submitted shall be accompanied by a "Statement of Compliance," signed by the contractor or subcontractor or his/her agent who pays or supervises the payment of the persons employed under the contract and shall certify the following:
 1. that the payroll for the payroll period contains the information required to be maintained under paragraph 2b of this Section V and that such information is correct and complete;
 2. that such laborer or mechanic (including each helper, apprentice, and trainee) employed on the contract during the payroll period has been paid the full weekly wages earned, without rebate, either directly or indirectly, and that no deductions have been made either directly or indirectly from the full wages earned, other than permissible deductions as set forth in the Regulations, 29 CFR 3;
 3. that each laborer or mechanic has been paid not less than the applicable wage rate and fringe benefits or cash equivalent for the classification of work performed, as specified in the applicable wage determination incorporated into the contract.
- e. The weekly submission of a properly executed certification set forth on the reverse side of Optional Form WH-347 shall satisfy the requirement for submission of the "Statement of Compliance" required by paragraph 2d of this Section V.
- f. The falsification of any of the above certifications may subject the contractor to civil or criminal prosecution under 18 U.S.C. 1001 and 31 U.S.C. 231.
- g. The contractor or subcontractor shall make the records required under paragraph 2b of this Section V available for inspection, copying, or transcription by authorized representatives of the SHA, the FHWA, or the DOL, and shall permit such representatives to interview employees during working hours on the job. If the contractor or subcontractor fails to submit the required records or to make them available, the SHA, the FHWA, the DOL, or all may, after written notice to the contractor, sponsor, applicant, or owner, take such actions as may be necessary to cause the suspension of any further payment, advance, or guarantee of funds. Furthermore, failure to submit the required records upon request or to make such records available may be grounds for debarment action pursuant to 29 CFR 5.12.

VI. RECORD OF MATERIALS, SUPPLIES AND LABOR THIS SECTION DELETED JUNE 4, 2007.

VII. SUBLETTING OR ASSIGNING THE CONTRACT

1. The contractor shall perform with its own organization contract work amounting to not less than 30 percent (or a greater percentage if specified elsewhere in the contract) of the total original contract price, excluding any specialty items designated by the State. Specialty items may be performed by subcontract and the amount of any such specialty items performed may be deducted from the total original contract price before

computing the amount of work required to be performed by the contractor's own organization (23 CFR 635).

- a. "Its own organization" shall be construed to include only workers employed and paid directly by the prime contractor and equipment owned or rented by the prime contractor, with or without operators. Such term does not include employees or equipment of a subcontractor, assignee, or agent of the prime contractor.
 - b. "Specialty Items" shall be construed to be limited to work that requires highly specialized knowledge, abilities, or equipment not ordinarily available in the type of contracting organizations qualified and expected to bid on the contract as a whole and in general are to be limited to minor components of the overall contract.
2. The contract amount upon which the requirements set forth in paragraph 1 of Section VII is computed includes the cost of material and manufactured products which are to be purchased or produced by the contractor under the contract provisions.
 3. The contractor shall furnish (a) a competent superintendent or supervisor who is employed by the firm, has full authority to direct performance of the work in accordance with the contract requirements, and is in charge of all construction operations (regardless of who performs the work) and (b) such other of its own organizational resources (supervision, management, and engineering services) as the SHA contracting officer determines is necessary to assure the performance of the contract.
 4. No portion of the contract shall be sublet, assigned or otherwise disposed of except with the written consent of the SHA contracting officer, or authorized representative, and such consent when given shall not be construed to relieve the contractor of any responsibility for the fulfillment of the contract. Written consent will be given only after the SHA has assured that each subcontract is evidenced in writing and that it contains all pertinent provisions and requirements of the prime contract.

VIII. SAFETY: ACCIDENT PREVENTION

1. In the performance of this contract the contractor shall comply with all applicable Federal, State, and local laws governing safety, health, and sanitation (23 CFR 635). The contractor shall provide all safeguards, safety devices and protective equipment and take any other needed actions as it determines, or as the SHA contracting officer may determine, to be reasonably necessary to protect the life and health of employees on the job and the safety of the public and to protect property in connection with the performance of the work covered by the contract.
2. It is a condition of this contract, and shall be made a condition of each subcontract, which the contractor enters into pursuant to this contract, that the contractor and any subcontractor shall not permit any employee, in performance of the contract, to work in surroundings or under conditions which are unsanitary, hazardous or dangerous to his/her health or safety, as determined under construction safety and health standards (29 CFR 1926) promulgated by the Secretary of Labor, in accordance with Section 107 of the Contract Work Hours and Safety Standards Act (40 U.S.C. 333).
3. Pursuant to 29 CFR 1926.3, it is a condition of this contract that the Secretary of Labor or authorized representative thereof, shall have right of entry to any site of contract

performance to inspect or investigate the matter of compliance with the construction safety and health standards and to carry out the duties of the Secretary under Section 107 of the Contract Work Hours and Safety Standards Act (40 U.S.C. 333).

IX. FALSE STATEMENTS CONCERNING HIGHWAY PROJECTS

In order to assure high quality and durable construction in conformity with approved plans and specifications and a high degree of reliability on statements and representations made by engineers, contractors, suppliers, and workers on Federal-aid highway projects, it is essential that all persons concerned with the project perform their functions as carefully, thoroughly, and honestly as possible. Willful falsification, distortion, or misrepresentation with respect to any facts related to the project is a violation of Federal law. To prevent any misunderstanding regarding the seriousness of these and similar acts, the following notice shall be posted on each Federal-aid highway project (23 CFR 635) in one or more places where it is readily available to all persons concerned with the project:

NOTICE TO ALL PERSONNEL ENGAGED ON FEDERAL-AID HIGHWAY PROJECTS

18 U.S.C. 1020 reads as follows:

"Whoever, being an officer, agent, or employee of the United States, or of any State or Territory, or whoever, whether a person, association, firm, or corporation, knowingly makes any false statement, false representation, or false report as to the character, quality, quantity, or cost of the material used or to be used, or the quantity or quality of the work performed or to be performed, or the cost thereof in connection with the submission of plans, maps, specifications, contracts, or costs of construction on any highway or related project submitted for approval to the Secretary of Transportation; or

Whoever knowingly makes any false statement, false representation, false report or false claim with respect to the character, quality, quantity, or cost of any work performed or to be performed, or materials furnished or to be furnished, in connection with the construction of any highway or related project approved by the Secretary of Transportation; or

Whoever knowingly makes any false statement or false representation as to material fact in any statement, certificate, or report submitted pursuant to provisions of the Federal-aid Roads Act approved July 1, 1916, (39 Stat. 355), as amended and supplemented;

Shall be fined not more than \$10,000 or imprisoned not more than 5 years or both."

X. IMPLEMENTATION OF CLEAN AIR ACT AND FEDERAL WATER POLLUTION CONTROL ACT

(Applicable to all Federal-aid construction contracts and to all related subcontracts of \$100,000 or more.)

By submission of this bid or the execution of this contract, or subcontract, as appropriate, the bidder, Federal-aid construction contractor, or subcontractor, as appropriate, will be deemed to have stipulated as follows:

1. That any facility that is or will be utilized in the performance of this contract, unless such contract is exempt under the Clean Air Act, as amended (42 U.S.C. 1857 *et seq.*, as amended by Pub.L. 91-604), and under the Federal Water Pollution Control Act, as amended (33 U.S.C. 1251 *et seq.*, as amended by Pub.L. 92-500), Executive Order 11738, and regulations in implementation thereof (40 CFR 15) is not listed, on the date of contract award, on the U.S. Environmental Protection Agency (EPA) List of Violating Facilities pursuant to 40 CFR 15.20.
2. That the firm agrees to comply and remain in compliance with all the requirements of Section 114 of the Clean Air Act and Section 308 of the Federal Water Pollution Control Act and all regulations and guidelines listed thereunder.
3. That the firm shall promptly notify the SHA of the receipt of any communication from the Director, Office of Federal Activities, EPA, indicating that a facility that is or will be utilized for the contract is under consideration to be listed on the EPA List of Violating Facilities.
4. That the firm agrees to include or cause to be included the requirements of paragraph 1 through 4 of this Section X in every nonexempt subcontract, and further agrees to take such action as the government may direct as a means of enforcing such requirements.

XI. CERTIFICATION REGARDING DEBARMENT, SUSPENSION, INELIGIBILITY AND VOLUNTARY EXCLUSION

1. Instructions for Certification - Primary Covered Transactions:

(Applicable to all Federal-aid contracts - 49 CFR 29)

- a. By signing and submitting this proposal, the prospective primary participant is providing the certification set out below.
- b. The inability of a person to provide the certification set out below will not necessarily result in denial of participation in this covered transaction. The prospective participant shall submit an explanation of why it cannot provide the certification set out below. The certification or explanation will be considered in connection with the department or agency's determination whether to enter into this transaction. However, failure of the prospective primary participant to furnish a certification or an explanation shall disqualify such a person from participation in this transaction.
- c. The certification in this clause is a material representation of fact upon which reliance was placed when the department or agency determined to enter into this transaction. If it is later determined that the prospective primary participant knowingly rendered an erroneous certification, in addition to other remedies available to the Federal Government, the department or agency may terminate this transaction for cause of default.

- d. The prospective primary participant shall provide immediate written notice to the department or agency to whom this proposal is submitted if any time the prospective primary participant learns that its certification was erroneous when submitted or has become erroneous by reason of changed circumstances.
- e. The terms "covered transaction," "debarred," "suspended," "ineligible," "lower tier covered transaction," "participant," "person," "primary covered transaction," "principal," "proposal," and "voluntarily excluded," as used in this clause, have the meanings set out in the Definitions and Coverage sections of rules implementing Executive Order 12549. You may contact the department or agency to which this proposal is submitted for assistance in obtaining a copy of those regulations.
- f. The prospective primary participant agrees by submitting this proposal that, should the proposed covered transaction be entered into, it shall not knowingly enter into any lower tier covered transaction with a person who is debarred, suspended, declared ineligible, or voluntarily excluded from participation in this covered transaction, unless authorized by the department or agency entering into this transaction.
- g. The prospective primary participant further agrees by submitting this proposal that it will include the clause titled "Certification Regarding Debarment, Suspension, Ineligibility and Voluntary Exclusion-Lower Tier Covered Transaction," provided by the department or agency entering into this covered transaction, without modification, in all lower tier covered transactions and in all solicitations for lower tier covered transactions.
- h. A participant in a covered transaction may rely upon a certification of a prospective participant in a lower tier covered transaction that is not debarred, suspended, ineligible, or voluntarily excluded from the covered transaction, unless it knows that the certification is erroneous. A participant may decide the method and frequency by which it determines the eligibility of its principals. Each participant may, but is not required to, check the nonprocurement portion of the "Lists of Parties Excluded From Federal Procurement or Nonprocurement Programs" (Nonprocurement List) which is compiled by the General Services Administration.
- i. Nothing contained in the foregoing shall be construed to require establishment of a system of records in order to render in good faith the certification required by this clause. The knowledge and information of participant is not required to exceed that which is normally possessed by a prudent person in the ordinary course of business dealings.
- j. Except for transactions authorized under paragraph f of these instructions, if a participant in a covered transaction knowingly enters into a lower tier covered transaction with a person who is suspended, debarred, ineligible, or voluntarily excluded from participation in this transaction, in addition to other remedies available to the Federal Government, the department or agency may terminate this transaction for cause or default.

* * * * *

Certification Regarding Debarment, Suspension, Ineligibility and Voluntary Exclusion--Primary Covered Transactions

1. The prospective primary participant certifies to the best of its knowledge and belief, that it and its principals:
 - a. Are not presently debarred, suspended, proposed for debarment, declared ineligible, or voluntarily excluded from covered transactions by any Federal department or agency;
 - b. Have not within a 3-year period preceding this proposal been convicted of or had a civil judgment rendered against them for commission of fraud or a criminal offense in connection with obtaining, attempting to obtain, or performing a public (Federal, State or local) transaction or contract under a public transaction; violation of Federal or State antitrust statutes or commission of embezzlement, theft, forgery, bribery, falsification or destruction of records, making false statements, or receiving stolen property;
 - c. Are not presently indicted for or otherwise criminally or civilly charged by a governmental entity (Federal, State or local) with commission of any of the offenses enumerated in paragraph 1b of this certification; and
 - d. Have not within a 3-year period preceding this application/proposal had one or more public transactions (Federal, State or local) terminated for cause or default.
2. Where the prospective primary participant is unable to certify to any of the statements in this certification, such prospective participant shall attach an explanation to this proposal.

* * * * *

2. Instructions for Certification - Lower Tier Covered Transactions:

(Applicable to all subcontracts, purchase orders and other lower tier transactions of \$25,000 or more - 49 CFR 29)

- a. By signing and submitting this proposal, the prospective lower tier is providing the certification set out below.
- b. The certification in this clause is a material representation of fact upon which reliance was placed when this transaction was entered into. If it is later determined that the prospective lower tier participant knowingly rendered an erroneous certification, in addition to other remedies available to the Federal Government, the department, or agency with which this transaction originated may pursue available remedies, including suspension and/or debarment.
- c. The prospective lower tier participant shall provide immediate written notice to the person to which this proposal is submitted if at any time the prospective lower tier participant learns that its certification was erroneous by reason of changed circumstances.
- d. The terms "covered transaction," "debarred," "suspended," "ineligible," "primary covered transaction," "participant," "person," "principal," "proposal," and "voluntarily excluded," as used in this clause, have the meanings set out in the

Definitions and Coverage sections of rules implementing Executive Order 12549. You may contact the person to which this proposal is submitted for assistance in obtaining a copy of those regulations.

- e. The prospective lower tier participant agrees by submitting this proposal that, should the proposed covered transaction be entered into, it shall not knowingly enter into any lower tier covered transaction with a person who is debarred, suspended, declared ineligible, or voluntarily excluded from participation in this covered transaction, unless authorized by the department or agency with which this transaction originated.
- f. The prospective lower tier participant further agrees by submitting this proposal that it will include this clause titled "Certification Regarding Debarment, Suspension, Ineligibility and Voluntary Exclusion-Lower Tier Covered Transaction," without modification, in all lower tier covered transactions and in all solicitations for lower tier covered transactions.
- g. A participant in a covered transaction may rely upon a certification of a prospective participant in a lower tier covered transaction that is not debarred, suspended, ineligible, or voluntarily excluded from the covered transaction, unless it knows that the certification is erroneous. A participant may decide the method and frequency by which it determines the eligibility of its principals. Each participant may, but is not required to, check the Nonprocurement List.
- h. Nothing contained in the foregoing shall be construed to require establishment of a system of records in order to render in good faith the certification required by this clause. The knowledge and information of participant is not required to exceed that which is normally possessed by a prudent person in the ordinary course of business dealings.
- i. Except for transactions authorized under paragraph e of these instructions, if a participant in a covered transaction knowingly enters into a lower tier covered transaction with a person who is suspended, debarred, ineligible, or voluntarily excluded from participation in this transaction, in addition to other remedies available to the Federal Government, the department or agency with which this transaction originated may pursue available remedies, including suspension and/or debarment.

* * * * *

Certification Regarding Debarment, Suspension, Ineligibility and Voluntary Exclusion--Lower Tier Covered Transactions:

1. The prospective lower tier participant certifies, by submission of this proposal, that neither it nor its principals is presently debarred, suspended, proposed for debarment, declared ineligible, or voluntarily excluded from participation in this transaction by any Federal department or agency.

2. Where the prospective lower tier participant is unable to certify to any of the statements in this certification, such prospective participant shall attach an explanation to this proposal.

* * * * *

XII. CERTIFICATION REGARDING USE OF CONTRACT FUNDS FOR LOBBYING

(Applicable to all Federal-aid construction contracts and to all related subcontracts which exceed \$100,000 - 49 CFR 20)

1. The prospective participant certifies, by signing and submitting this bid or proposal, to the best of his or her knowledge and belief, that:
 - a. No Federal appropriated funds have been paid or will be paid, by or on behalf of the undersigned, to any person for influencing or attempting to influence an officer or employee of any Federal agency, a Member of Congress, an officer or employee of Congress, or an employee of a Member of Congress in connection with the awarding of any Federal contract, the making of any Federal grant, the making of any Federal loan, the entering into of any cooperative agreement, and the extension, continuation, renewal, amendment, or modification of any Federal contract, grant, loan, or cooperative agreement.
 - b. If any funds other than Federal appropriated funds have been paid or will be paid to any person for influencing or attempting to influence an officer or employee of any Federal agency, a Member of Congress, an officer or employee of Congress, or an employee of a Member of Congress in connection with this Federal contract, grant, loan, or cooperative agreement, the undersigned shall complete and submit Standard Form-LLL, "Disclosure Form to Report Lobbying," in accordance with its instructions.
2. This certification is a material representation of fact upon which reliance was placed when this transaction was made or entered into. Submission of this certification is a prerequisite for making or entering into this transaction imposed by 31 U.S.C. 1352. Any person who fails to file the required certification shall be subject to a civil penalty of not less than \$10,000 and not more than \$100,000 for each such failure.
3. The prospective participant also agrees by submitting his or her bid or proposal that he or she shall require that the language of this certification be included in all lower tier subcontracts, which exceed \$100,000 and that all such recipients shall certify and disclose accordingly.

COMPLIANCE WITH EXECUTIVE ORDER 11246

During the performance of this contract, the contractor agrees as follows:

1. The contractor will not discriminate against any employee or applicant for employment because of race, creed, color, or national origin. The contractor will take affirmative action to ensure that applicants are employed, and that employees are treated, during employment without regard to their race, creed, color, or national origin. Such action shall include, but not be limited to the following: Employment, upgrading, demotion or transfer, recruitment or recruitment advertising; layoff or termination; rates of pay or other forms of compensation; and selection for training, including apprenticeship. The contractor agrees to post in conspicuous place, available to employees and applicants for employment, notices to be provided setting forth the provisions of this non-discrimination clause.

2. The contractor will, in all solicitations or advertisements for employees placed on behalf of the contractor, state that all qualified applicants will receive consideration for employment without regard to race, creed, color, or national origin.

3. The contractor will send to each labor union or representative of workers with which he has a collective bargaining agreement or other contract of understanding, a notice to be provided advising the said labor union or worker's representative of the contractor's commitments under this section, and shall post copies of the notice in conspicuous place available to employees and applicants for employment. The contractor will take such action with respect to any subcontract or purchase order as the administering agency may direct as a means of enforcing such provisions, including sanctions for noncompliance.

In case the work to be performed is paid for in whole or in part with funds obtained from the Federal Government or borrowed on the credit of the Federal Government pursuant to a grant, contract, loan, insurance or guarantee, or undertaken pursuant to any Federal Program involving such grant, contract, loan, insurance or guarantee, during the performance of this contract, the Contractor, in addition, agrees to comply with:

4. All provisions of the latest current Executive Order and executive amendments, of the rules, regulations and relevant orders of the President's Committee on Equal Employment Opportunity created thereby.

5. The contractor will furnish all information and reports required by the Executive, and by the rules, regulations and orders of the said committee, or pursuant thereto, and will permit access to his books, records and accounts by the administering agency and the Committee for purposes of investigation to ascertain compliance with such rules, regulations and orders.

6. In the event of the contractor's noncompliance with the non-discrimination clauses of this contract or with any of the said rules, regulations or orders, this contract may be canceled, terminated or suspended in whole or in part and the contractor may be declared ineligible for further

Government contracts or Federally assigned construction contracts in accordance with procedures authorized in the Executive Order, and such other sanctions may be imposed and remedies invoked as provided in the said Executive Order or by rule, regulation or order of the President's Committee on Equal Employment Opportunity or as otherwise provided by law.

7. The contractor will include the provisions of Paragraphs (1) through (7) in every sub-contract or purchase order unless exempted by rules, regulations or orders of the President's Committee on Equal Employment Opportunity, so that provisions will be binding upon each sub-contractor or vendor. The contractor will take such action with respect to any sub-contractor purchase order as the administering agency may direct as a means of enforcing such provisions, including sanctions for noncompliance; provided, however, that in the event a contractor becomes involved in, or is threatened with, litigation with a sub-contractor or vendor as a result of such direction by the agency, the contractor may request the United States to enter into such litigation to protect the interests of the United States.

NOTICE OF REQUIREMENT FOR AFFIRMATIVE ACTION TO ENSURE EQUAL
EMPLOYMENT OPPORTUNITY
(EXECUTIVE ORDER 11246)

1. The Offeror's or Bidder's attention is called to the "Equal Opportunity Clause" and the Standard Federal Equal Employment Opportunity Construction Specifications" set forth herein.
2. The goals and timetables for minority and female participation, expressed in percentage terms for the Contractor's aggregate workforce in each trade on all construction work in the covered area, are as follows:

<u>Timetables</u>	Goals for minority	Goals for female
Current	participation for each trade 10.8%	participation in each trade 6.9%

These goals are applicable to all the Contractor's construction work performed in the covered area, whether or not it is federally assisted.

The Contractor's compliance with the Executive Order and the regulations in 41 CFR Part 60-4 shall be based on its implementation of the Equal Opportunity Clause, specific affirmative action obligations required by the specifications set forth in 41 CFR 60.4.3(a), and its efforts to meet the goals established for the geographical area where the contract resulting from this solicitation is to be performed. The hours of minority and female employment and training must be substantially uniform throughout the length of the contract, and in each trade, and the contractor shall make a good faith effort to employ minorities and women evenly on each of its projects. The transfer of minority or female employees or trainees from Contractor to Contractor or from project to project to project for the sole purpose of meeting the Contractor's goals shall be a violation of the contract, the Executive Order and the regulations in 41 CFR Part 60-4. Compliance with the goals will be measured against the total work hours performed.

3. The Contractor shall provide written notification to the Director of the Office of Federal Contract Compliance Programs within 10 working days of award of any construction subcontract in excess of \$10,000 at any tier for construction work under the contract resulting from this solicitation. The notification shall list the name, address and telephone number of the subcontractor; employer identification number; estimated dollar amount of the subcontract; estimated starting and completion dates of the subcontract; and the geographical area in which the contract is to be performed.
4. As used in this Notice, and in the contract resulting from this solicitation, the "covered area" is the State of Kentucky, County of Fayette, City of Lexington.

REPORTING REQUIREMENTS

Notice of awarding agency requirements and regulations pertaining to reporting.

A. **Preconstruction Conference**

Before Contractor starts the work at the proposed site, a conference attended by the Contractor, Engineer/Architect, Contract Compliance Officer, and other appropriate parties will be held to discuss the following issues: (1) The scheduling of the work to be completed; (2) The procedures for handling shop drawings and other submittals; (3) The processing of applications for payment; (4) The establishment of an understanding among the involved parties in regard to the proposed project; and (5) The establishment of procedures for effectively implementing the 10% minimum DBE goals.

B. **Documents Required of Contractor**

Documentation showing the percentage of the DBE employment levels on each project of the Bidder's current work force, and DBE participation levels for Subcontractors.

C. **Optional Owner Requirements**

The Owner, at its discretion, may require the Contractor to provide: (1) financial security in amounts and kind deemed necessary by the Owner or require other financial security to meet the financial responsibility requirements of the Contractor to indemnify the Owner; (2) Additional information and/or DBE work data, as well as DBE participation data.

PATENT RIGHT REQUIREMENTS

Notice of awarding agency requirements and regulations pertaining to patent rights with respect to any discovery or invention which arises or is developed in the course of or under such contract.

§ 401.14 STANDARD PATENT RIGHTS CLAUSES

The following is the standard patent rights clause to be used as specified in §401.3(a).

Patent Rights (Small Business Firms and Nonprofit Organizations)

A. Definitions

1. "Invention" means any invention or discovery which is or may be patentable or otherwise protectable under Title 35 of the United States Code, or any novel variety of plant which is or may be protected under the Plant Variety Protection Act (7 U.S.C. 2321 et seq.).
2. "Subject invention" means any invention of the **contractor** conceived or first actually reduced to practice in the performance of work under this **contract**, provided that in the case of a variety of plant, the date of determination (as defined in section 41(d) of the Plant Variety Protection Act, 7 U.S.C. 2401(d) must also occur during the period of **contract** performance.
3. "Practical Application" means to manufacture in the case of a composition or product, to practice in the case of a process or method, or to operate in the case of a machine or system; and, in each case, under such conditions as to establish that the invention is being utilized and that its benefits are, to the extent permitted by law or government regulations, available to the public on reasonable terms.
4. "Made" when used in relation to any invention means the conception or first actual reduction to practice such invention.
5. "Small Business Firm" means a small business concern as defined at section 2 of Pub. L. 85-536 (15 U.S.C. 632) and implementing regulations of the Administrator of the Small Business Administration. For the purpose of this clause, the size standards for small business concerns involved in government procurement and subcontracting at 13 CFR 121.3-8 and 13 CFR 121.3-12, respectively, will be used.
6. "Nonprofit Organization" means a university or other institution of higher education or an organization of the type described in section 501(c)(3) of the Internal Revenue Code of 1954 (26 U.S.C. 501(c) and exempt from taxation under section 501(a) of

the Internal Revenue Code (25 U.S.C 501 (a)) or any nonprofit scientific or educational organization qualified under a state nonprofit organization statute.

B. Allocation of Principal Rights

1. The **Contractor** may retain the entire right, title, and interest throughout the world to each subject invention, subject to the provisions of this clause and 35 U.S.C. 203. With respect to any subject invention in which the **Contractor** retains title, the Federal Government shall have a nonexclusive, nontransferable, irrevocable, paid-up license to practice or have practiced for or on behalf of the United States the subject invention throughout the world.

C. Invention Disclosure, Election of Title and Filing of Patent Application by **Contractor**.

1. The **Contractor** will disclose each subject invention to the Federal Agency within two months after the inventor discloses it in writing to **contractor** personnel responsible for patent matters. The disclosure to the agency shall be in the form of a written report and shall identify the contract under which the invention was made and the inventor(s). It shall be sufficiently complete in technical detail to convey a clear understanding to the extent known at the time of the disclosure, of the nature, purpose, operation, and the physical, chemical, biological or electrical characteristics of the invention. The disclosure shall also identify any publication, on sale or public use of the invention and whether a manuscript describing the invention has been submitted for publication and, if so, whether it has been accepted for publication at the time of disclosure. In addition, after disclosure to the agency the Contractor will promptly notify the agency of the acceptance of any manuscript describing the invention for publication or of any on sale or public use planned by the contractor.
2. The Contractor will elect in writing whether or not to retain title to any such invention by notifying the Federal agency within two years of disclosure to the Federal agency. However, in any case where publication, on sale or public use has initiated the one year statutory period wherein valid patent protection can still be obtained in the United States, the period for election of title may be shortened by the agency to a date that is no more than 60 days prior to the end of the statutory period.
3. The Contractor will file its initial patent application on a subject invention to which it elects to retain title within one year after election of title or, if earlier, prior to the end of any statutory period wherein valid patent protection can be obtained in the United States after a publication, on sale, or public use. The Contractor will file patent applications in additional countries or international patent offices within either ten months of the corresponding initial patent application or six months from the date permission is granted by the Commissioner of Patents and Trademarks to

file foreign patent applications where such filing has been prohibited by a Secrecy Order.

4. Requests for extension of the time for disclosure, election, and filing under subparagraphs (1), (2), and (3) may, at the discretion of the agency, be granted.

D. Conditions When the Government May Obtain Title

The Contractor will convey to the Federal agency, upon written request, title to any subject invention--

1. If the contractor fails to disclose or elect title to the subject invention within the times specified in (C), above, or elects not to retain title; provided that the agency may only request title within 60 days after learning of the failure of the contractor to disclose or elect within the specified times.
2. In those countries in which the contractor fails to file patent applications within the times specified in (C) above; provided, however, that if the contractor has filed a patent application in a country after the times specified in (C) above, but prior to its receipt of the written request of the Federal agency, the contractor shall continue to retain title in that country.
3. In any country in which the contractor decides not to continue the prosecution of any application for, to pay the maintenance fees on, or defend in reexamination or opposition proceeding on, a patent on a subject invention.

E. Minimum Rights to Contractor and Protection of the Contractor Right to File

1. The contractor will retain a nonexclusive royalty-free license throughout the world in each subject invention to which the Government obtains title, except if the contractor fails to disclose the invention within the times specified in (C), above. The contractor's license extends to its domestic subsidiary and affiliates, if any, within the corporate structure of which the contractor is a party and includes the right to grant sublicenses of the same scope to the extent the contractor was legally obligated to do so at the time the contract was awarded. The license is transferable only with the approval of the Federal agency except when transferred to the successor of that party of the contractor's business to which the invention pertains.
2. The contractor's domestic license may be revoked or modified by the funding Federal agency to the extent necessary to achieve expeditious practical application of the subject invention pursuant to an application for an exclusive license submitted in accordance with applicable provisions at 37 CFR Part 404 and agency licensing regulations (if any). This license will not be revoked in that field of use or the geographical areas in which the contractor has achieved practical application and

continues to make the benefits of the invention reasonably accessible to the public. The license in any foreign country may be revoked or modified at the discretion of the funding Federal agency to the extent the contractor, its licensees, or the domestic subsidiaries or affiliates have failed to achieve practical application in that foreign country.

3. Before revocation or modification of the license, the funding Federal agency will furnish the contractor a written notice of its intention to revoke or modify the license, and the contractor will be allowed thirty days (or such other time as may be authorized by the funding Federal agency for good cause shown by the contractor) after the notice to show cause why the license should not be revoked or modified. The contractor has the right to appeal, in accordance with applicable regulations in 37 CFR Part 404 and agency regulations (if any) concerning the licensing of Government-owned inventions, any decision concerning the revocation or modification of the license.

F. Contractor Action to Protect the Government's Interest

1. The contractor agrees to execute or to have executed and promptly deliver to the Federal agency all instruments necessary to (i) establish or confirm the rights the Government has throughout the world in those subject inventions to which the contractor elects to retain title, and (ii) convey title to the Federal agency when requested under paragraph (D) above and to enable the government to obtain patent protection throughout the world in that subject invention.
2. The contractor agrees to require, by written agreement, its employees, other than clerical and non-technical employees, to disclose promptly in writing to personnel identified as responsible for the administration of patent matters and in a format suggested by the contractor each subject invention made under contract in order that the contractor can comply with the disclosure provisions of paragraph (C), above, and to execute all papers necessary to file patent applications on subject inventions and to establish the government's rights in the subject inventions. This disclosure format should require, as a minimum, the information required by (C)(1), above. The contractor shall instruct such employees through employee agreements or other suitable educational programs on the importance of reporting inventions in sufficient time to permit the filing of patent applications prior to U.S. or foreign statutory bars.
3. The contractor will notify the Federal agency of any decisions not to continue the prosecution of a patent application, pay maintenance fees, or defend in a reexamination or opposition proceeding on a patent, in any country, not less than thirty days before the expiration of the response period required by the relevant patent office.

4. The contractor agrees to include, within the specification of any United States patent applications and any patent issuing thereon covering a subject invention, the following statement, "This invention was made with government support under (identify the contract) awarded by (identify the Federal agency). The government has certain rights in the invention."

G. Subcontracts

1. The contractor will include this clause, suitably modified to identify the parties, in all subcontracts, regardless of tier for experimental, developmental or research work to be performed by a small business firm or domestic nonprofit organization. The subcontractor will retain all rights provided for the contractor in this clause, and the contractor will not, as part of the consideration for awarding the subcontractor, obtain rights in the subcontractor's subject inventions.
2. The contractor will include in all other subcontracts, regardless of tier, for experimental developmental or research work the patent rights clause required by (cite section of agency implementing regulations or FAR).
3. In the case of subcontracts, at any tier, when the prime award with the Federal agency was a contract (but not a grant or cooperative agreement), the agency, subcontractor, and the contractor agree that the mutual obligations of the parties created by this clause constitute a contract between the subcontractor and the Federal agency with respect to the matters covered by the clause; provided, however, that nothing in this paragraph is intended to confer any jurisdiction under the Contract Disputes Act in connection with proceedings under paragraph (J) of this clause.

H. Reporting Utilization of Subject Inventions

1. The Contractor agrees to submit on request periodic reports no more frequently than annually on the utilization of a subject invention or on efforts at obtaining such utilization that are being made by the contractor or its licensees or assignees. Such reports shall include information regarding the status of development, date of first commercial sale or use, gross royalties received by the contractor, and such other data and information as the agency may reasonably specify. The contractor also agrees to provide additional reports as may be requested by the agency in connection with any march-in proceeding undertaken by the agency in accordance with paragraph (J) of this clause. As required by 35 U.S.C. 202 (C)(5), the agency agrees it will not disclose such information to persons outside the government without permission of the contractor.

I. Preference for United States Industry

Notwithstanding any other provision of this clause, the contractor agrees that neither it nor any assignee will grant to any person the exclusive right to use or sell any subject inventions in the United States unless such person agrees that any products embodying the subject invention or produced through the use of the subject invention will be manufactured substantially in the United States. However, in individual cases, the requirement for such an agreement may be waived by the Federal agency upon a showing by the contractor or its assignee that reasonable but unsuccessful efforts have been made to grant licenses that would be likely to manufacture substantially in the United States or that under the circumstances domestic manufacture is not commercially feasible.

J. March-in Rights

The contractor agrees that with respect to any subject invention in which it has acquired title, the Federal agency has the right in accordance with the procedures in 37 CFR 401.6 and any supplemental regulations of the agency to require the contractor, an assignee or exclusive licensee of a subject invention to grant a nonexclusive, partially exclusive, or exclusive license in any field of use to a responsible applicant or applicants, upon terms that are reasonable under the circumstances, and if the contractor, assignee, or exclusive licensee refuses such a request the Federal agency has the right to grant such a license itself if the Federal agency determines that:

1. Such action is necessary because the contractor or assignee has not taken, or is not expected to take within a reasonable time, effective steps to achieve practical application of the subject invention in such field of use.
2. Such action is necessary to alleviate health or safety needs which are not reasonably satisfied by the contractor, assignee or their licensees:
3. Such action is necessary to meet requirements for public use specified by Federal regulations and such requirements are not reasonably satisfied by the contractor, assignee or licensees; or
4. Such action is necessary because the agreement required by paragraph (I) of this clause has not been obtained or waived or because a licensee of the exclusive right to use or sell any subject invention in the United States is in breach of such agreement.

K. Special Provisions for Contracts with Nonprofit Organizations

If the Contractor is a nonprofit organization, it agrees that:

1. Rights to a subject invention in the United States may not be assigned without the approval of the Federal agency, except where such assignment is made to an organization which has as one of its primary functions the management of

inventions, provided that such assignee will be subject to the same provisions as the contractor.

2. The contractor will share royalties collected on a subject invention with the inventor, including Federal employee co-inventors (when the agency deems it appropriate) when the subject invention is assigned in accordance with 35 U.S.C. 202(e) and 37 CFR 401.10;
3. The balance of any royalties or income earned by the contractor with respect to subject inventions, after payment of expenses (including payments to inventors) incidental to the administration of subject inventions, will be utilized for the support of scientific research or education; and
4. It will make efforts that are reasonable under the circumstances to attract licensees of subject invention that are small business firms and that it will give a preference to a small business firm when licensing a subject invention if the contractor determines that the small business firm has a plan or proposal for marketing the invention which, if executed, is equally as likely to bring the invention to practical application as any plans or proposals from applicants that are not small business firms; provided, that the contractor is also satisfied that the small business firm has the capability and resources to carry out its plan or proposal. The decision whether to give a preference in any specific case will be at the discretion of the contractor. However, the contractor agrees that the Secretary may review the contractor's licensing program and decisions regarding small business applicants, and the contractor will negotiate changes to its licensing policies, procedures, or practices with the Secretary when the Secretary's review discloses that the contractor could take reasonable steps to implement more effectively the requires of this paragraph (K)(4).

1. Communication

(Complete According to Instruction at 401.5(b))

(b) When the Department of Energy (DOE) determines to use alternative provisions under § 401.3(a)(4), the standard clause at § 401.14(a), above, shall be used with the following modifications unless a substitute clause is drafted by DOE:

- (1) The title of the clause shall be changed to read as follows: Patent Rights to Nonprofit DOE Facility Operators
- (2) Add an "(A)" after "(1)" in paragraph (c)(1) and add subparagraphs (B) and (C) to paragraph (c)(1) as follows:

- (B) If the subject invention occurred under activities funded by the naval nuclear propulsion or weapons related programs of DOE, then the provisions of this subparagraph (c)(1)(B) will apply in lieu of paragraphs (c)(2) and (3). In such cases the contractor agrees to assign the government the entire right, title, and interest thereto throughout the world in and to the subject invention except to the extent that rights are retained by the contractor through a greater rights determination or under paragraph (e), below. The contractor, or an employee-inventor, with authorization of the contractor, may submit a request for greater rights at the time the invention is disclosed or within a reasonable time thereafter. DOE will process such a request in accordance with procedures at 37 CFR 401.15. Each determination of greater rights will be subject to paragraphs (h)-(k) of this clause and such additional conditions, if any, deemed to be appropriate by the Department of Energy.
 - (C) At the time an invention is disclosed in accordance with (c)(1)(A) above, or within 90 days thereafter, the contractor will submit a written statement as to whether or not the invention occurred under a naval nuclear propulsion or weapons-related program of the Department of Energy. If this statement is not filed within this time, subparagraph (c)(1)(B) will apply in lieu of paragraphs (c)(2) and (3). The contractor statement will be deemed conclusive unless, within 60 days thereafter, the Contracting Officer disagrees in writing, in which case the determination of the Contracting Officer will be deemed conclusive unless the contractor files a claim under the Contract Disputes Act within 60 days after the Contracting Officer's determination. Pending resolution of the matter, the invention will be subject to subparagraph (c)(1)(B).
3. Paragraph (k)(3) of the clause will be modified as prescribed at § 401.5(g).

§ 401.15 Deferred Determinations

- (a) This section applies to requests for greater rights in subject inventions made by contractors when deferred determination provisions were included in the funding agreement because one of the exceptions at § 401.3(a) was applied, except that the Department of Energy is authorized to process deferred determinations either in accordance with its waiver regulations or this section. A contractor requesting greater rights should include with its request information on its plans and intentions to being the invention to practical application. Within 90 days after receiving a request and supporting information, or sooner if a statutory bar to patenting is imminent,

the agency should seek to make a determination. In any event, if a bar to patenting is imminent, unless the agency plans to file on its own, it shall authorize the contractor to file a patent application pending a determination by the agency. Such a filing shall normally be at the contractor's own risk and expense. However, if the agency subsequently refuses to allow the contractor to retain title and elects to proceed with the patent application under government ownership, it shall reimburse the contractor for the cost of preparing and filing the patent application.

- (b) If the circumstances of concerns which originally led the agency to invoke an exception under § 401.3(a) are not applicable to the actual subject invention or are no longer valid because of subsequent events, the agency should allow the contractor to retain title to the invention on the same conditions as would have applied if the standard clause at § 401.14(a) had been used originally, unless it has been licensed.
- (c) If paragraph (b) is not applicable, the agency shall make its determination based on an assessment whether its own plans regarding the invention will better promote the policies and objectives of 35 U.S.C. 200 than will contractor ownership of the invention. Moreover, if the agency is concerned only about specific uses or applications of the invention, it shall consider leaving title in the contractor with additional conditions imposed upon the contractor's use of the invention for such applications or with expanded government license rights in such applications.
- (d) A determination not to allow the contractor to retain title to a subject invention or to restrict or condition its title with conditions differing from those in the clause at § 401.14(a), unless made by the head of the agency, shall be appealable by the contractor to an agency official at a level above the person who made the determination. This appeal shall be subject to the procedures applicable to appeals under § 401.11 of this part.

§ 401.16 Submissions and Inquiries

All submissions or inquiries should be directed to Federal Technology Management Policy Division, telephone number 202-377-0659, Room H4837, U.S. Department of Commerce, Washington, DC 20230
(FR Doc. 87-5618 Filed 3-17-87: 8:45 am)

COPYRIGHT REQUIREMENTS

Awarding agency requirements and regulations pertaining to copyrights and rights in data.

COPYRIGHTS

Federally supported grant research projects frequently result in the production of books, brochures, manuals, articles, films, or other written materials. In most instances they are technical reports which serve to disseminate the results of a project to the public and to the scientific community or other researchers. Often, however, these documents are publishable and occasionally they have significant commercial value. Who controls the rights to these materials? What rights does the Government retain? What are the grantee's responsibilities in handling the materials?

There is a widely held notion that written materials produced with the support of public money are automatically in the public domain. That view is erroneous, and in fact no member of the public has an inherent right to use grant-produced materials merely because they were prepared under Government assistance. Because of the confusion, however, it is important for grantees to note a few features of the copyright law which relate to the subject of the grants.

In general, researchers have exclusive rights in any original works of their authorship. Under the most recent amendment to the copyright law, statutory copyright protection extends to both published and unpublished works of the author. Researchers are cautioned to observe the publication policies of their institutions or organizations in this regard, and unless there is an express agreement to the contrary, their employing institution may be considered the author of any materials prepared in the course of their employment, under the "works for hire" doctrine.

Under the most recent amendments to the copyright law, it is clear that grant reports are not considered works of the Government which are in the public domain. The legislative history of the law shows that Congress expressly left it to the discretion of the individual grant-making agencies to determine whether written materials produced by their grantees should be placed in the public domain, and it expected the questions to be resolved by the terms and conditions of grants. The House Report No. 94-1476, September 3, 1976, stated on page 59:

A more difficult and far-reaching problem is whether the definition should be broadened to prohibit copyright in works prepared under U.S. Government contract or grant. As the bill is written, the Government agency concerned could determine in each case whether to allow an independent contractor or grantee to secure copyright in works prepared in whole or in part with the use of Government funds. The argument that has been made against allowing copyright in this situation is that the public should not be required to pay a "double subsidy," and that it is inconsistent to prohibit copyright in works by Government employees while permitting private copyrights in a growing body of works created by persons who are paid with Government funds. Those arguing in favor of potential copyright protection have stressed the importance

of copyright as an incentive to creation and dissemination in this situation, and the basically different policy considerations, applicable to works written by Government employees and those applicable to works prepared by private organizations with the use of Federal funds.

The bill deliberately avoids making any sort of outright, unqualified prohibition against copyright in works prepared under Government contract or grant. There may be cases where it would be in the public interest to deny copyright in the writings generated by Government research contracts and the like; it can be assumed that, where a Government agency commissions a work for its own use merely as an alternative to having one of its own employees prepare the work, the right to secure a private copyright would be withheld. However, there are almost certainly many other cases where the denial of copyright protection would be unfair or would hamper the production and publication of important works. Where, under the particular circumstances, Congress or the agency involved finds the need to have a work freely available outweighs the need of the private author to secure copyright, the problem can be dealt with by specific legislation, agency regulations, or contractual restrictions.

Agency Policy

Government-wide policies contained in Office of Management and Budget Circulars A-102 and A-110 speak to the issue of copyrightable materials through their respective Attachments N. Circular A-110 states:

8b. Copyrights. - Except as otherwise provided in the terms and conditions of the agreement, the author or the recipient organization is free to copyright any books, publications, or other copyrightable materials developed in the course of or under a Federal agreement, but the Federal sponsoring agency shall reserve a royalty-free, nonexclusive and irrevocable right to reproduce, publish, or otherwise use, and to authorize others to use, the work for Government purposes.

Except for minor, nonsubstantive differences, the provisions of A-102 are identical. Each permits the grantee to copyright published materials, subject to a license for the U.S. Government to use the materials for Government purposes. Each also gives the grantor agency discretion in altering that condition, by establishing different terms and conditions in its grants.

Suggested steps for grantees

A grantee whose grant-financed activity may involve the need for potential need for copyrighting of materials should:

- Check the terms and conditions of the grant to determine whether a copyright can be asserted in unpublished as well as published materials. This may vary from grantor agency to grantor agency and from grant to grant.
- It is the grantee's obligation to take the necessary steps to preserve the Government's license when conveying rights to publishers. If the publisher provides a release form that does not contain a reference to Government use of the materials, appropriate language should be inserted that preserves the Government's rights. If necessary, the granting agency should be consulted to assure compliance with the terms of the grant.
- Under most Federal grants, proper acknowledgment of the source of funds used to write a published work will be required. For example, the National Science Foundation **Grant General Conditions** require the following acknowledgment of support and disclaimer statement in any publication of material, whether copyrighted or not: "This material is based upon work supported by the National Science Foundation under Grant No. _____." Except for scientific articles and papers appearing in scientific journals, all materials must also contain the following disclaimer:

Any opinions, findings and conclusions or recommendations expressed in this publication are those of the author(s) and do not necessarily reflect the views of the National Science Foundation.

- When negotiating a publication agreement, the grantee must include in the publishing contract the reservation of Government license and the acknowledgment and disclaimer statements.
- Grants often are made with the stipulation that any substantive technical reports will be made available to the public through the U.S. Department of Commerce, National Technical Information Service (NTIS). Again, the grantee is well advised to check the terms and conditions of its grant agreement to see if such requirements exist and, if so, to account for them in dealing with potential publishers.
- Provide copies of copyrighted work to the granting agency.
- Some agencies may require prior approval of any proposed commercial publication, including approval of the selection process by which a publisher is obtained. The National Science Foundation, for example, requires documentation showing that a reasonable number of qualified publishers were given an opportunity to compete for the materials. Also, the selection criteria are subject to examination, as well as the final publishing contract.

With respect to any discovery or invention which arises or is developed in the course of or under this contract, Lexington-Fayette Urban County Government and/or Owner shall have the right to

require the contractor, an assignee or exclusive licensee of a subject invention to grant a non-exclusive, partially exclusive, or exclusive license in any field of use to Lexington-Fayette Urban County Government and/or Owner.

With respect to any copyrights and rights in data, Lexington-Fayette Urban County Government and/or Owner shall have the right to retain all copyrights and rights in data.

ACCESS TO RECORDS REQUIREMENTS

Access by the grantee, the subgrantee, the Federal grantor agency, the Comptroller General of the United States, or any of their duly authorized representatives to any books, documents, papers, and records of the contractor which are directly pertinent to that specific contract for the purpose of making audit, examination, excerpts, and transcriptions.

ACCESS TO RECORDS

The Contractor agrees that the Lexington-Fayette Urban County Government, the Owner, the Comptroller General of the United States, or any of their duly authorized representatives, shall have access to any and all books, documents, papers, and records of the Contractor which are directly pertinent to this specific project for the purposes of making an audit, examination, excerpts, and transcriptions.

RECORDS RETENTION REQUIREMENTS

Retention of all required records for three years after contractors or subcontractors make final payments and all other pending matters are closed.

CONTRACT AWARD RESTRICTION TO FOREIGN COUNTRIES

Contractor agrees to fully comply with applicable terms and conditions in Section 109 of Pub. L. 100-102 as set forth below:

RESTRICTIONS ON PUBLIC BUILDINGS AND PUBLIC WORKS PROJECTS

(A) Definitions. "Component" as used in this clause means those articles, materials, and supplies incorporated directly into the product.

"Contractor or subcontractor of a foreign country," as used in this clause, means any Contractor or Subcontractor that is a citizen or national of a foreign country or is controlled directly or indirectly by citizens or nationals of a foreign country. A contractor or subcontractor shall be considered to be a citizen or national of a foreign country or controlled directly or indirectly by citizens or nationals of a foreign country.

- (1) If 50 percent or more of the Contractor or Subcontractor is owned by a citizen or a national of the foreign country;
- (2) If the title of to 50 percent or more of the stock of the Contractor or Subcontractor is held subject to trust or fiduciary obligation in favor of citizens or nationals of the foreign country;
- (3) If 50 percent or more of the voting power in the Contractor-Subcontractor is vested in or exercisable on behalf of a citizen or national of the foreign country;
- (4) In the case of a partnership, if any general partner is a citizen of the foreign country;
- (5) In the case of a corporation, if its president or other chief executive officer or the chairman of its board of directors is a citizen of the foreign country or the majority of any number of its directors necessary to constitute a quorum are citizens of the foreign country or the corporation is organized under the laws of the foreign country or any subdivision, territory, or possession thereof; or
- (6) In the case of a Contractor or Subcontractor who is a joint venture, if any participant firm is a citizen or national of a foreign country or meets any of the criteria in subparagraphs (a)(1) through (5) of this clause.

"Product", as used in this clause, means construction materials-i.e., articles, materials, and supplies brought to the construction site for incorporation into the public works project, including permanently affixed equipment, instruments, utilities, electronic or other devices, but not including vehicles or construction equipment. In determining the origin of a product Lexington-Fayette Urban County Government and/or Owner will consider a product as produced in a foreign country if it has been assembled or manufactured in the foreign

country, or if the cost of the components mined, produced, or manufactured in the foreign country exceed 50 percent of the cost of all its components.

- (b) Restrictions. The Contractor shall not (1) knowingly enter into any subcontract under this contract with a Subcontractor of a foreign country on the list of countries that discriminate against U.S. firms published by the United States Trade Representative (see paragraph (c) of this clause, or (2) supply any product under this contract of a country included on the list of foreign countries that discriminate against U.S. firms published by the USTR.
- (c) USTR list. The USTR published an initial list in the Federal Register on December 30, 1987 (53 FR 49244), which identified one country - Japan. The USTR can add other countries to the list or remove countries from it in accordance with Section 109 (c) of Pub. L 100-202.
- (d) Certification. The Contractor may rely upon the certification of a prospective Subcontractor that it is not a Subcontractor of a foreign country included on the list of countries that discriminate against U.S. firms published by the USTR and that products supplied by such Subcontractor for use on the Federal public works project under this contract are not products of a foreign country included on the list of foreign countries that discriminate against U.S. firms published by the USTR, unless such Contractor has knowledge that the certification is erroneous.
- (e) Subcontracts. The Contractor shall incorporate this clause, modified only for the purpose of properly identifying the parties in all subcontracts. This paragraph (e) shall also be incorporated in all subcontracts.

(End of Contract Clause)

Bids/proposals from such firms/suppliers shall be deemed nonresponsible and rejected.

Questions related to this issue should be directed to Division of Community Development, Lexington-Fayette Urban County Government, 200 E. Main Street 6th Floor, Lexington, Kentucky 40507.

KENTUCKY EQUAL EMPLOYMENT OPPORTUNITY ACT

The Kentucky Equal Employment Opportunity Act of 1978 (KRS 45.570-45.640) requires that any county, city, town, school district, water district, hospital district, or other political subdivision of the state shall include in directly or indirectly publicly funded contracts for supplies, materials, services or equipment hereinafter entered into the following provisions:

During the performance of this contract, the contractor agrees as follows:

1. The contractor will not discriminate against any employee or applicant for employment because of race, color, religion, sex, age, or national origin;
2. The contractor will state in all solicitations or advertisements for employees placed by or on behalf of the contractor that all qualified applicants will receive consideration for employment without regard to race, color, religion, sex, age, or national origin;
3. The contractor will post notices in conspicuous places, available to employees and applicants for employment, setting forth the provisions of the nondiscrimination clauses required by this section; and
4. The contractor will send a notice to each labor union or representative of workers with which he has a collective bargaining agreement or other contract or understanding advising the labor union or worker's representative of the contractor's commitments under the non discrimination clauses.

The Act further provides:

KRS 45.610. Hiring Minorities - Information Required

1. For the length of the contract, each contractor shall hire minorities from other sources within the drawing area, should the union with which he has collective bargaining agreements be unwilling to supply sufficient minorities to satisfy the agreed upon goals and timetables.
2. Each contractor shall, for the length of the contract, furnish such information as required by KRS 45.560 to KRS 45.640 and by such rules, regulations and orders issued pursuant thereto and will permit access to all books and records pertaining to his employment practices and work sites by the contracting agency and the department for purposes of investigation to ascertain compliance with KRS 45.560 to KRS 45.640 and such rules, regulations and orders issued pursuant thereto.

KRS 45.620. Action Against Contractor -- Hiring of Minority Contractor or Subcontractor

1. If any contractor is found by the department to have engaged in an unlawful practice under this chapter during the course of performing under a contract or subcontract covered under KRS 45.560 to 45.640, the department shall so certify to the contracting agency and such certifications shall be binding upon the contracting agency unless it is reversed in the course of judicial review.
2. If the contractor is found to have committed an unlawful practice under KRS 45.560 to 45.640, the contracting agency may cancel or terminate the contract, conditioned upon a program for future compliance approved by the contracting agency and the department. The contracting agency may declare such a contractor ineligible to bid on further contracts with that agency until such time as the contractor complies in full with the requirements of KRS 45.560 to 45.640.
3. The equal employment provisions of KRS 45.560 to 45.640 may be met in part by a contractor by subcontracting to a minority subcontractor or subcontractor. For the provisions of KRS 45.560 to 45.640, a minority contractor or subcontractor shall mean a business that is owned and controlled by one or more persons disadvantaged by racial or ethnic circumstances.

KRS 45.630. Termination of existing employee not required, when:

Any provision of KRS 45.560 to 45.640 notwithstanding, no contractor shall be required to terminate an existing employee, upon proof that the employee was employed prior to the date of the contract.

KRS 45.640. Minimum Skills

Nothing in KRS 45.560 to 45.640 shall require a contractor to hire anyone who fails to demonstrate the minimum skills required to perform a particular job.

OTHER FEDERAL REQUIREMENTS

INTEREST OF CERTAIN FEDERAL OFFICIALS

No member of or Delegate to the Congress of the United States and no Resident Commission, shall be admitted to any share or part of this Agreement or to any benefit to arise from the same.

INTEREST OF MEMBERS, OFFICERS, OR EMPLOYEES OF PUBLIC BODY, MEMBER OF LOCAL GOVERNING BODY, OR OTHER PUBLIC OFFICIALS

No member, officer, or employee of the Public Body, or its designees or agents, no member of the governing body of the locality in which the program is situated, and no other public official of such locality or localities who exercises any functions or responsibilities with respect to the program during his tenure or for one year thereafter, shall have any interest, direct or indirect, in any contract or sub-contract, or the proceeds thereof, for work to be performed in connection with the program assisted under this Agreement.

PROHIBITION AGAINST PAYMENTS OF BONUS OR COMMISSION

The assistance provided under this Agreement shall not be used in the payment of any bonus or commission for the purpose of obtaining Federal approval of the application for such assistance, or approval of applications for additional assistance, or any other approval of concurrence required under this Agreement with respect thereto; provided, however, that reasonable fees or bonafide technical, consultant, managerial or other such services, other than actual solicitation, are not hereby prohibited if otherwise eligible as program costs.

PUBLIC LAW 88-352: TITLE VI OF THE CIVIL RIGHTS
ACT OF 1964

The Developer agrees to insure that no person shall on the ground of race, color, or national origin, be excluded from participation in, be denied the benefits of, or be subjected to discrimination under any program in the multi-family rental housing facility developed through this contract.

PUBLIC LAW 90-284: TITLE VIII OF THE CIVIL RIGHTS ACT
OF 1968 AND EXECUTIVE ORDER 11063

The Developer warrants and assures that they and their agents will not discriminate in the rental or leasing of housing units constructed under this contract and will in no way make unavailable or deny a dwelling to any person, because of race, color, religion, sex or national origin.

SECTION 109

The Developer will not on the ground of race, color, national origin, sex, age, or handicap:

1. Deny an facilities, services, financial aid or other benefits provided under the program or activity.
2. Provide any facilities, services, financial aid or other benefits which are different, or are provided in a different form from that provided to others under the program or activity.
3. Subject to segregated or separate treatment in any facility in, or in any matter of process related to receipt of any service or benefit under the program or activity.
4. Restrict in any way access to, or in the enjoyment of any advantage or privilege enjoyed by others in connection with facilities, services, financial aid or other benefits under the program or activity.
5. Treat any individual differently from others in determining whether the individual satisfies any admission, enrollment, eligibility, membership, or other requirement or condition which individual must meet in order to be provided any facilities, services or other benefit provided under the program or activity.
6. Deny an opportunity to participate in a program or activity as an employee.

COMPLIANCE WITH THE CLEAN AIR AND WATER ACTS

Compliance with all applicable standards, orders, or requirements issued under section 206 of the Clean Air Act (42 U.S.C. 1857)(h), Section 506 of the Clean Water Act (33 U.S.C. 1368), Executive Order 11738, and Environmental Protection Agency regulations (40 CFR Part 15). (Contracts, subcontracts, and subgrants of amounts in excess of \$100,000).

COMPLIANCE WITH AIR AND WATER ACTS

This Agreement is subject to the requirements of the Clean Air Act, as amended, 42 USC 1857 et. seq., the Federal Water Pollution Control Act, as amended, 33 U.S.C. 1251 et seq. and the regulations of the Environmental Protection Agency with respect thereto, at 40 CFR Part 15, as amended from time to time.

The Contractor and any of its subcontractors for work funded under this Agreement, in excess of \$100,000 agree to the following requirements:

1. A stipulation by the Contractor or subcontractors that any facility to be utilized in the performance of any non-exempt contract or subcontract is not listed on the List of Violating Facilities issued by the Environmental Protection Agency (EPA) pursuant to 40 CFR 15.20.
2. Agreement by the Contractor to comply with all requirements of Section 114 of the Clean Air Act, as amended, (42 U.S.C. 1857c-8) and Section 308 of the Federal Water Pollution Control Act, as amended, (33 U.S.C. 1318) relating to inspection, monitoring, entry, reports and information, as well as all other requirements specified in said Section 114 and Section 308, and all regulations and guidelines issued there under.
3. A stipulation that as a condition for the award of the Contract prompt notice will be given of any notification received from the Director, Office of Federal Activities, EPA indicating that a facility utilized or to be utilized for the Contract is under consideration to be listed on the EPA list of Violating Facilities.
4. Agreement by the Contractor that he/she will include or cause to be included the criteria and requirements in paragraph (1) through (4) of this section in every nonexempt subcontract and requiring that the Contractor will take such action as the Government may direct as a means of enforcing such provision.

In no event shall any amount of assistance provided under this Agreement be utilized with respect to a facility which has given rise to a conviction under Section 113(c)(1) of the Clean Air Act or Section 309(c) of the Federal Water Pollution Control Act.

ENERGY EFFICIENCY REQUIREMENTS

Mandatory standards and policies relating to energy efficiency which are contained in the state energy conservation plan issued in compliance with the Energy Policy and Conservation Act (Pub. L.94-163).

LEAD BASED PAINT

- A. All paint to be lead free.
- B. Existing lead paint to be removed or concealed with an acceptable covering (paint, siding, etc.)
- C. Warning
 - 1. Use of lead-base paint materials on any surface, interior or exterior, is prohibited.
 - 2. Lead-base paint removal is a dangerous task and safety precautions should be strictly enforced when workers are engaged in hazard abatement.

POTENTIAL DBE CONTRACTOR'S LIST CONTACT

For a listing of DBE (Disadvantaged Business Enterprise) contractors/subcontractors, please contact:

Sherita Miller/Todd Slatin
Division of Central Purchasing
200 E. Main Street, 3rd Floor
Lexington, KY 40507
(859) 258-3326
TDD [hearing impaired only] (859) 258-3606

EQUAL EMPLOYMENT OPPORTUNITY AFFIRMATIVE ACTION POLICY

It is the policy of _____
to assure that all applicants for employment and all employees are treated on a fair and equitable basis without regard to their race, religion, sex, color, handicap, natural origin or age.

Such action shall include employment, promotion, demotion, recruitment or recruitment advertising, layoff or termination, rates of pay and other forms of compensation, and selection for training, whether apprenticeship and/or on-the-job-training.

Furthermore, this company agrees to make special recruitment efforts to hire the protected class whenever feasible. This company also agrees to adhere to all applicable federal, state, and local laws relating to Equal Employment Opportunity for all individuals.

_____ has been appointed Equal Employment Compliance (EEOC) Officer and shall be available for counseling, answering of questions in regards to this company policy, and to hear any complaints of discrimination. The EEOC Office may be reached by calling _____.

Signature: _____
(Bidding Contractor)

Title: _____

Date: _____

DEBARMENT CERTIFICATION

All contractors/subcontractors shall complete the following certification and submit it with the bid proposal.

The contractor/subcontractor certifies in accordance with Executive Order 12549 (Debarment and Suspension 2/18/86) that to the best of its knowledge and belief, that it and its principals:

- 1) Are not presently debarred, suspended, proposed for debarment, declared negligible, or voluntarily excluded from covered transactions or contract by any Federal department or agency for noncompliance with the Federal Labor Standards, Title VI of the Civil Rights Act of 1964 as amended, Executive Order 11246 as amended or any other Federal law;
 - a) Have not within a three year period preceding this proposal been convicted of or had a civil judgment rendered against them for commission of fraud or a criminal offense in connection with obtaining, attempting to obtain, or performing a public (Federal, State or local) transaction or contract under a public transaction; violation of Federal or State antitrust statutes or commission of embezzlement, theft, forgery, bribery, falsification or destruction of records, making false statements, or receiving stolen property;
 - b) Are not presently indicted for or otherwise criminally or civilly charged by a government entity (Federal, State or local) with commission of any of the offenses enumerated in paragraph (1)(a) of this certification; and
 - c) Have not within a three year period preceding this bid has one or more public (Federal, State or local) transactions or contracts terminated for cause or default.
- 2) Where the contractor is unable to certify to any of the statements in this certification, such prospective contractors shall attach an explanation to this certification form.

Firm Name: _____

Project: _____

Printed Name and Title of Authorized Representative: _____

Signature: _____

Date: _____

General Decision Number: KY180100 01/19/2018 KY100

Superseded General Decision Number: KY20170100

State: Kentucky

Construction Type: Highway

Counties: Anderson, Bath, Bourbon, Boyd, Boyle, Bracken, Breckinridge, Bullitt, Carroll, Carter, Clark, Elliott, Fayette, Fleming, Franklin, Gallatin, Grant, Grayson, Greenup, Hardin, Harrison, Henry, Jefferson, Jessamine, Larue, Lewis, Madison, Marion, Mason, Meade, Mercer, Montgomery, Nelson, Nicholas, Oldham, Owen, Robertson, Rowan, Scott, Shelby, Spencer, Trimble, Washington and Woodford Counties in Kentucky.

HIGHWAY CONSTRUCTION PROJECTS (excluding tunnels, building structures in rest area projects & railroad construction; bascule, suspension & spandrel arch bridges designed for commercial navigation, bridges involving marine construction; and other major bridges).

Note: Under Executive Order (EO) 13658, an hourly minimum wage of \$10.35 for calendar year 2018 applies to all contracts subject to the Davis-Bacon Act for which the contract is awarded (and any solicitation was issued) on or after January 1, 2015. If this contract is covered by the EO, the contractor must pay all workers in any classification listed on this wage determination at least \$10.35 per hour (or the applicable wage rate listed on this wage determination, if it is higher) for all hours spent performing on the contract in calendar year 2018. The EO minimum wage rate will be adjusted annually. Please note that this EO applies to the above-mentioned types of contracts entered into by the federal government that are subject to the Davis-Bacon Act itself, but it does not apply to contracts subject only to the Davis-Bacon Related Acts, including those set forth at 29 CFR 5.1(a)(2)-(60). Additional information on contractor requirements and worker protections under the EO is available at www.dol.gov/whd/govcontracts.

Modification Number Publication Date

0 01/05/2018
1 01/19/2018

BRIN0004-003 06/01/2017

BRECKENRIDGE COUNTY

	Rates	Fringes
BRICKLAYER.....	\$ 26.80	12.38

BRKY0001-005 06/01/2017

BULLITT, CARROLL, GRAYSON, HARDIN, HENRY, JEFFERSON, LARUE,
MARION, MEADE, NELSON, OLDHAM, SHELBY, SPENCER, & TRIMBLE
COUNTIES:

	Rates	Fringes
BRICKLAYER.....	\$ 26.80	12.38

BRKY0002-006 06/01/2017

BRACKEN, GALLATIN, GRANT, MASON & ROBERTSON COUNTIES:

	Rates	Fringes
BRICKLAYER.....	\$ 27.81	13.01

BRKY0007-004 06/01/2017

BOYD, CARTER, ELLIOT, FLEMING, GREENUP, LEWIS & ROWAN COUNTIES:

	Rates	Fringes
BRICKLAYER.....	\$ 32.98	19.02

BRKY0017-004 06/01/2017

ANDERSON, BATH, BOURBON, BOYLE, CLARK, FAYETTE, FRANKLIN,
HARRISON, JESSAMINE, MADISON, MERCER, MONTGOMERY, NICHOLAS,
OWEN, SCOTT, WASHINGTON & WOODFORD COUNTIES:

	Rates	Fringes
BRICKLAYER.....	\$ 26.47	12.76

 CARP0064-001 05/01/2015

	Rates	Fringes
CARPENTER.....	\$ 27.50	16.06
Diver.....	\$ 41.63	16.06
PILEDRIVERMAN.....	\$ 27.75	16.06

 ELEC0212-008 06/05/2017

BRACKEN, GALLATIN and GRANT COUNTIES

	Rates	Fringes
ELECTRICIAN.....	\$ 27.90	17.56

 ELEC0212-014 12/01/2014

BRACKEN, GALLATIN & GRANT COUNTIES:

	Rates	Fringes
Sound & Communication Technician.....	\$ 22.75	10.08

 ELEC0317-012 06/01/2016

BOYD, CARTER, ELLIOT & ROWAN COUNTIES:

	Rates	Fringes
ELECTRICIAN (Wiremen)		
Cable Splicer.....	\$ 32.68	18.13
Electrician.....	\$ 33.31	22.98

 ELEC0369-007 05/31/2017

ANDERSON, BATH, BOURBON, BOYLE, BRECKINRIDGE, BULLITT, CARROLL,
 CLARK, FAYETTE, FRAONKLIN, GRAYSON, HARDIN, HARRISON, HENRY,

JEFFERSON, JESSAMINE, LARUE, MADISON, MARION, MEADE, MERCER,
MONTGOMERY, NELSON, NICHOLAS, OLDHAM, OWEN, ROBERTSON, SCOTT,
SHELBY, SPENCER, TRIMBLE, WASHINGTON, & WOODFORD COUNTIES:

	Rates	Fringes
ELECTRICIAN.....	\$ 31.07	16.60

ELEC0575-002 05/29/2017		

FLEMING, GREENUP, LEWIS & MASON COUNTIES:

	Rates	Fringes
ELECTRICIAN.....	\$ 32.15	15.77

ENGI0181-018 07/01/2017		

	Rates	Fringes
POWER EQUIPMENT OPERATOR		
GROUP 1.....	\$ 31.95	15.15
GROUP 2.....	\$ 29.09	15.15
GROUP 3.....	\$ 29.54	15.15
GROUP 4.....	\$ 28.77	15.15

OPERATING ENGINEER CLASSIFICATIONS

GROUP 1 - A-Frame Winch Truck; Auto Patrol; Backfiller;
Batcher Plant; Bituminous Paver; Bituminous Transfer
Machine; Boom Cat; Bulldozer; Mechanic; Cableway; Carry-All
Scoop; Carry Deck Crane; Central Compressor Plant; Cherry
Picker; Clamshell; Concrete Mixer (21 cu. ft. or Over);
Concrete Paver; Truck-Mounted Concrete Pump; Core Drill;
Crane; Crusher Plant; Derrick; Derrick Boat; Ditching &
Trenching Machine; Dragline; Dredge Operator; Dredge
Engineer; Elevating Grader & Loaders; Grade-All; Gurries;
Heavy Equipment Robotics Operator/Mechanic; High Lift;
Hoe-Type Machine; Hoist (Two or More Drums); Hoisting
Engine (Two or More Drums); Horizontal Directional Drill
Operator; Hydrocrane; Hyster; KeCal Loader; LeTourneau;
Locomotive; Mechanic; Mechanically Operated Laser Screed;
Mechanic Welder; Mucking Machine; Motor Scraper; Orangepeel

Bucket; Overhead Crane; Piledriver; Power Blade; Pumpcrete; Push Dozer; Rock Spreader, attached to equipment; Rotary Drill; Roller (Bituminous); Rough Terrain Crane; Scarifier; Scoopmobile; Shovel; Side Boom; Subgrader; Tailboom; Telescoping Type Forklift; Tow or Push Boat; Tower Crane (French, German & other types); Tractor Shovel; Truck Crane; Tunnel Mining Machines, including Moles, Shields or similar types of Tunnel Mining Equipment

GROUP 2 - Air Compressor (Over 900 cu. ft. per min.); Bituminous Mixer; Boom Type Tamping Machine; Bull Float; Concrete Mixer (Under 21 cu. ft.); Dredge Engineer; Electric Vibrator; Compactor/Self-Propelled Compactor; Elevator (One Drum or Buck Hoist); Elevator (When used to Hoist Building Material); Finish Machine; Firemen & Hoist (One Drum); Flexplane; Forklift (Regardless of Lift Height); Form Grader; Joint Sealing Machine; Outboard Motor Boat; Power Sweeper (Riding Type); Roller (Rock); Ross Carrier; Skid Mounted or Trailer Mounted Concrete Pump; Skid Steer Machine with all Attachments; Switchman or Brakeman; Throttle Valve Person; Tractair & Road Widening Trencher; Tractor (50 H.P. or Over); Truck Crane Oiler; Tugger; Welding Machine; Well Points; & Whirley Oiler

GROUP 3 - All Off Road Material Handling Equipment, including Articulating Dump Trucks; Greaser on Grease Facilities servicing Heavy Equipment

GROUP 4 - Bituminous Distributor; Burlap & Curing Machine; Cement Gun; Concrete Saw; Conveyor; Deckhand Oiler; Grout Pump; Hydraulic Post Driver; Hydro Seeder; Mud Jack; Oiler; Paving Joint Machine; Power Form Handling Equipment; Pump; Roller (Earth); Steerman; Tamping Machine; Tractor (Under 50 H.P.); & Vibrator

CRANES - with booms 150 ft. & Over (Including JIB), and where the length of the boom in combination with the length of the piling leads equals or exceeds 150 ft. - \$1.00 over Group 1 rate

EMPLOYEES ASSIGNED TO WORK BELOW GROUND LEVEL ARE TO BE PAID

10%
ABOVE BASIC WAGE RATE. THIS DOES NOT APPLY TO OPEN CUT WORK.

IRON0044-009 06/01/2017

BRACKEN, GALLATIN, GRANT, HARRISON, ROBERTSON,
BOURBON (Northern third, including Townships of Jackson,
Millersburg, Ruddel Mills & Shawhan);
CARROLL (Eastern third, including the Township of Ghent);
FLEMING (Western part, excluding Townships of Beechburg, Colfax,
Elizaville, Flemingsburg, Flemingsburg Junction, Foxport,
Grange City, Hillsboro, Hilltop, Mount Carmel, Muses Mills,
Nepton, Pecksridge, Plummers Landing, Plummers Mill, Poplar
Plains, Ringos Mills, Tilton & Wallingford);
MASON (Western two-thirds, including Townships of Dover,
Lewisburg, Mays Lick, Maysville, Minerva, Moranburg,
Murphysville, Ripley, Sardis, Shannon, South Ripley &
Washington);
NICHOLAS (Townships of Barefoot, Barterville, Carlisle,
Ellisville, Headquarters, Henryville, Morningglory, Myers &
Oakland Mills);
OWEN (Townships of Beechwood, Bromley, Fairbanks, Holbrook,
Jonesville, Long Ridge, Lusby's Mill, New, New Columbus, New
Liberty, Owenton, Poplar Grove, Rockdale, Sanders, Teresita &
Wheatley);
SCOTT (Northern two-thirds, including Townships of Biddle,
Davis, Delaplain, Elmville, Longlick, Muddy Ford, Oxford,
Rogers Gap, Sadieville, Skinnersburg & Stonewall)

Rates Fringes

IRONWORKER		
Fence Erector.....	\$ 23.76	19.15
Structural.....	\$ 27.60	20.10

IRON0070-006 06/01/2017

ANDERSON, BOYLE, BRECKINRIDGE, BULLITT, FAYETTE, FRANKLIN,
GRAYSON, HARDIN, HENRY, JEFFERSON, JESSAMINE, LARUE, MADISON,
MARION, MEADE, MERCER, NELSON, OLDHAM, SHELBY, SPENCER,
TRIMBLE, WASHINGTON & WOODFORD
BOURBON (Southern two-thirds, including Townships of Austerlity,
Centerville, Clintonville, Elizabeth, Hutchison, Littlerock,
North Middletown & Paris);

CARROLL (Western two-thirds, including Townships of Carrollton, Easterday, English, Locust, Louis, Prestonville & Worthville);
 CLARK (Western two-thirds, including Townships of Becknerville, Flanagan, Ford, Pine Grove, Winchester & Wyandotte);
 OWEN (Eastern eighth, including Townships of Glenmary, Gratz, Monterey, Perry Park & Tacketts Mill);
 SCOTT (Southern third, including Townships of Georgetown, Great Crossing, Newtown, Stamplng Ground & Woodlake);

	Rates	Fringes
IRONWORKER.....	\$ 28.30	21.85

 * IRON0769-007 06/01/2017

BATH, BOYD, CARTER, ELLIOTT, GREENUP, LEWIS, MONTGOMERY & ROWAN
 CLARK (Eastern third, including townships of Bloomingdale, Hunt, Indian Fields, Kiddville, Loglick, Rightangele & Thomson);
 FLEMING (Townships of Beechburg, Colfax, Elizaville, Flemingsburg, Flemingsburg Junction, Foxport, Grange City, Hillsboro, Hilltop, Mount Carmel, Muses Mills, Nepton, Pecksrige, Plummers Landing, Plummers Mill, Poplar Plains, Ringos Mills, Tilton & Wallingford);
 MASON (Eastern third, including Townships of Helena, Marshall, Orangeburg, Plumville & Springdale);
 NICHOLAS (Eastern eighth, including the Township of Moorefield Sprout)

	Rates	Fringes
IRONWORKER		
ZONE 1.....	\$ 31.33	23.97
ZONE 2.....	\$ 31.33	23.97
ZONE 3.....	\$ 31.33	23.97

ZONE 1 - (no base rate increase) Up to 10 mile radius of Union Hall, 1643 Greenup Ave, Ashland, KY.

ZONE 2 - (add \$0.40 per hour to base rate) 10 to 50 mile radius of Union Hall, 1643 Greenup Ave, Ashland, KY.

ZONE 3 - (add \$2.00 per hour to base rate) 50 mile radius & over of Union Hall, 1643 Greenup Ave, Ashland, KY.

LABO0189-003 07/01/2016

BATH, BOURBON, BOYD, BOYLE, BRACKEN, CARTER, CLARK, ELLIOTT, FAYETTE, FLEMING, FRANKLIN, GALLATIN, GRANT, GREENUP, HARRISON, JESSAMINE, LEWIS, MADISON, MASON, MERCER, MONTGOMERY, NICHOLAS, OWEN, ROBERTSON, ROWAN, SCOTT, & WOOLFORD COUNTIES

	Rates	Fringes
Laborers:		
GROUP 1.....	\$ 23.14	13.29
GROUP 2.....	\$ 23.39	13.29
GROUP 3.....	\$ 23.44	13.29
GROUP 4.....	\$ 24.04	13.29

LABORERS CLASSIFICATIONS

GROUP 1 - Aging & Curing of Concrete; Asbestos Abatement Worker; Asphalt Plant; Asphalt; Batch Truck Dump; Carpenter Tender; Cement Mason Tender; Cleaning of Machines; Concrete; Demolition; Dredging; Environmental - Nuclear, Radiation, Toxic & Hazardous Waste - Level D; Flagperson; Grade Checker; Hand Digging & Hand Back Filling; Highway Marker Placer; Landscaping, Mesh Handler & Placer; Puddler; Railroad; Rip-rap & Grouter; Right-of-Way; Sign, Guard Rail & Fence Installer; Signal Person; Sound Barrier Installer; Storm & Sanitary Sewer; Swamper; Truck Spotter & Dumper; Wrecking of Concrete Forms; General Cleanup

GROUP 2 - Batter Board Man (Sanitary & Storm Sewer); Brickmason Tender; Mortar Mixer Operator; Scaffold Builder; Burner & Welder; Bushhammer; Chain Saw Operator; Concrete Saw Operator; Deckhand Scow Man; Dry Cement Handler; Environmental - Nuclear, Radiation, Toxic & Hazardous Waste - Level C; Forklift Operator for Masonary; Form Setter; Green Concrete Cutting; Hand Operated Grouter & Grinder Machine Operator; Jackhammer; Pavement Breaker; Paving Joint Machine; Pipelayer; Plastic Pipe Fusion; Power Driven

Georgia Buggy & Wheel Barrow; Power Post Hole Digger; Precast Manhole Setter; Walk-Behind Tamper; Walk-Behind Trencher; Sand Blaster; Concrete Chipper; Surface Grinder; Vibrator Operator; Wagon Driller

GROUP 3 - Asphalt Luteman & Raker; Gunnite Nozzleman; Gunnite Operator & Mixer; Grout Pump Operator; Side Rail Setter; Rail Paved Ditches; Screw Operator; Tunnel (Free Air); Water Blaster

GROUP 4 - Caisson Worker (Free Air); Cement Finisher; Environmental - Nuclear, Radiation, Toxic & Hazardous Waste - Levels A & B; Miner & Driller (Free Air); Tunnel Blaster; & Tunnel Mucker (Free Air); Directional & Horizontal Boring; Air Track Drillers (All Types); Powdermen & Blasters; Troxler & Concrete Tester if Laborer is Utilized

LABO0189-008 07/01/2017

ANDERSON, BULLITT, CARROLL, HARDIN, HENRY, JEFFERSON, LARUE, MARION, MEADE, NELSON, OLDHAM, SHELBY, SPENCER, TRIMBLE & WASHINGTON COUNTIES

	Rates	Fringes
Laborers:		
GROUP 1.....	\$ 23.14	13.29
GROUP 2.....	\$ 23.39	13.29
GROUP 3.....	\$ 23.44	13.29
GROUP 4.....	\$ 24.04	13.29

LABORERS CLASSIFICATIONS

GROUP 1 - Aging & Curing of Concrete; Asbestos Abatement Worker; Asphalt Plant; Asphalt; Batch Truck Dump; Carpenter Tender; Cement Mason Tender; Cleaning of Machines; Concrete; Demolition; Dredging; Environmental - Nuclear, Radiation, Toxic & Hazardous Waste - Level D; Flagperson; Grade Checker; Hand Digging & Hand Back Filling; Highway Marker Placer; Landscaping, Mesh Handler & Placer; Puddler; Railroad; Rip-rap & Grouter; Right-of-Way; Sign, Guard Rail & Fence Installer; Signal Person; Sound Barrier Installer;

Storm & Sanitary Sewer; Swamper; Truck Spotter & Dumper;
Wrecking of Concrete Forms; General Cleanup

GROUP 2 - Batter Board Man (Sanitary & Storm Sewer);
Brickmason Tender; Mortar Mixer Operator; Scaffold Builder;
Burner & Welder; Bushhammer; Chain Saw Operator; Concrete
Saw Operator; Deckhand Scow Man; Dry Cement Handler;
Environmental - Nuclear, Radiation, Toxic & Hazardous Waste
- Level C; Forklift Operator for Masonary; Form Setter;
Green Concrete Cutting; Hand Operated Grouter & Grinder
Machine Operator; Jackhammer; Pavement Breaker; Paving
Joint Machine; Pipelayer; Plastic Pipe Fusion; Power Driven
Georgia Buggy & Wheel Barrow; Power Post Hole Digger;
Precast Manhole Setter; Walk-Behind Tamper; Walk-Behind
Trencher; Sand Blaster; Concrete Chipper; Surface Grinder;
Vibrator Operator; Wagon Driller

GROUP 3 - Asphalt Luteman & Raker; Gunnite Nozzleman;
Gunnite Operator & Mixer; Grout Pump Operator; Side Rail
Setter; Rail Paved Ditches; Screw Operator; Tunnel (Free
Air); Water Blaster

GROUP 4 - Caisson Worker (Free Air); Cement Finisher;
Environmental - Nuclear, Radiation, Toxic & Hazardous Waste
- Levels A & B; Miner & Driller (Free Air); Tunnel Blaster;
& Tunnel Mucker (Free Air); Directional & Horizontal
Boring; Air Track Drillers (All Types); Powdermen &
Blasters; Troxler & Concrete Tester if Laborer is Utilized

LABO0189-009 07/01/2014

BRECKINRIDGE & GRAYSON COUNTIES

	Rates	Fringes
Laborers:		
GROUP 1.....	\$ 22.66	11.10
GROUP 2.....	\$ 22.91	11.10
GROUP 3.....	\$ 22.96	11.10
GROUP 4.....	\$ 23.56	11.10

LABORERS CLASSIFICATIONS

GROUP 1 - Aging & Curing of Concrete; Asbestos Abatement Worker; Asphalt Plant; Asphalt; Batch Truck Dump; Carpenter Tender; Cement Mason Tender; Cleaning of Machines; Concrete; Demolition; Dredging; Environmental - Nuclear, Radiation, Toxic & Hazardous Waste - Level D; Flagperson; Grade Checker; Hand Digging & Hand Back Filling; Highway Marker Placer; Landscaping, Mesh Handler & Placer; Puddler; Railroad; Rip-rap & Grouter; Right-of-Way; Sign, Guard Rail & Fence Installer; Signal Person; Sound Barrier Installer; Storm & Sanitary Sewer; Swamper; Truck Spotter & Dumper; Wrecking of Concrete Forms; General Cleanup

GROUP 2 - Batter Board Man (Sanitary & Storm Sewer); Brickmason Tender; Mortar Mixer Operator; Scaffold Builder; Burner & Welder; Bushhammer; Chain Saw Operator; Concrete Saw Operator; Deckhand Scow Man; Dry Cement Handler; Environmental - Nuclear, Radiation, Toxic & Hazardous Waste - Level C; Forklift Operator for Masonary; Form Setter; Green Concrete Cutting; Hand Operated Grouter & Grinder Machine Operator; Jackhammer; Pavement Breaker; Paving Joint Machine; Pipelayer; Plastic Pipe Fusion; Power Driven Georgia Buggy & Wheel Barrow; Power Post Hole Digger; Precast Manhole Setter; Walk-Behind Tamper; Walk-Behind Trencher; Sand Blaster; Concrete Chipper; Surface Grinder; Vibrator Operator; Wagon Driller

GROUP 3 - Asphalt Luteman & Raker; Gunnite Nozzleman; Gunnite Operator & Mixer; Grout Pump Operator; Side Rail Setter; Rail Paved Ditches; Screw Operator; Tunnel (Free Air); Water Blaster

GROUP 4 - Caisson Worker (Free Air); Cement Finisher; Environmental - Nuclear, Radiation, Toxic & Hazardous Waste - Levels A & B; Miner & Driller (Free Air); Tunnel Blaster; & Tunnel Mucker (Free Air); Directional & Horizontal Boring; Air Track Drillers (All Types); Powdermen & Blasters; Troxler & Concrete Tester if Laborer is Utilized

PAIN0012-005 06/11/2005

BATH, BOURBON, BOYLE, CLARK, FAYETTE, FLEMING, FRANKLIN,
HARRISON, JESSAMINE, MADISON, MERCER, MONTGOMERY, NICHOLAS,
ROBERTSON, SCOTT & WOODFORD COUNTIES:

Rates Fringes

PAINTER

Bridge/Equipment Tender and/or Containment Builder..\$ 18.90	5.90
Brush & Roller.....\$ 21.30	5.90
Elevated Tanks; Steeplejack Work; Bridge & Lead Abatement.....\$ 22.30	5.90
Sandblasting & Waterblasting.....\$ 22.05	5.90
Spray.....\$ 21.80	5.90

PAIN0012-017 05/01/2015

BRACKEN, GALLATIN, GRANT, MASON & OWEN COUNTIES:

Rates Fringes

PAINTER (Heavy & Highway
Bridges - Guardrails -
Lightpoles - Striping)

Bridge Equipment Tender and Containment Builder.....\$ 20.73	9.06
Brush & Roller.....\$ 23.39	9.06
Elevated Tanks; Steeplejack Work; Bridge & Lead Abatement.....\$ 24.39	9.06
Sandblasting & Water Blasting.....\$ 24.14	9.06
Spray.....\$ 23.89	9.06

PAIN0118-004 06/01/2014

ANDERSON, BRECKINRIDGE, BULLITT, CARROLL, GRAYSON, HARDIN,
HENRY, JEFFERSON, LARUE, MARION, MEADE, NELSON, OLDHAM, SHELBY,
SPENCER, TRIMBLE & WASHINGTON COUNTIES:

Rates Fringes

PAINTER

Brush & Roller.....	\$ 18.50	11.97
Spray, Sandblast, Power Tools, Waterblast & Steam Cleaning.....	\$ 19.50	11.97

PAIN1072-003 12/01/2017

BOYD, CARTER, ELLIOTT, GREENUP, LEWIS and ROWAN COUNTIES

Rates	Fringes
-------	---------

Painters:

Bridges; Locks; Dams; Tension Towers & Energized Substations.....	\$ 33.33	15.45
Power Generating Facilities.	\$ 30.09	15.45

PLUM0248-003 06/01/2017

BOYD, CARTER, ELLIOTT, GREENUP, LEWIS & ROWAN COUNTIES:

Rates	Fringes
-------	---------

Plumber and Steamfitter.....	\$ 35.00	25.12
------------------------------	----------	-------

PLUM0392-007 06/01/2014

BRACKEN, CARROLL (Eastern Half), GALLATIN, GRANT, MASON, OWEN &
ROBERTSON COUNTIES:

Rates	Fringes
-------	---------

Plumbers and Pipefitters.....	\$ 29.80	17.79
-------------------------------	----------	-------

PLUM0502-003 08/01/2017

BRECKINRIDGE, BULLITT, CARROLL (Western Half), FRANKLIN
(Western three-fourths), GRAYSON, HARDIN, HENRY, JEFFERSON,
LARUE, MARION, MEADE, NELSON, OLDHAM, SHELBY, SPENCER, TRIMBLE
&
WASHINGTON COUNTIES

	Rates	Fringes
PLUMBER.....	\$ 33.12	20.78

 SUKY2010-160 10/08/2001

	Rates	Fringes
Truck drivers:		
GROUP 1.....	\$ 16.57	7.34
GROUP 2.....	\$ 16.68	7.34
GROUP 3.....	\$ 16.86	7.34
GROUP 4.....	\$ 16.96	7.34

TRUCK DRIVER CLASSIFICATIONS

GROUP 1 - Mobile Batch Truck Tender

GROUP 2 - Greaser; Tire Changer; & Mechanic Tender

GROUP 3 - Single Axle Dump; Flatbed; Semi-trailer or Pole Trailer when used to pull building materials and equipment; Tandem Axle Dump; Distributor; Mixer; & Truck Mechanic

GROUP 4 - Euclid & Other Heavy Earthmoving Equipment & Lowboy; Articulator Cat; 5-Axle Vehicle; Winch & A-Frame when used in transporting materials; Ross Carrier; Forklift when used to transport building materials; & Pavement Breaker

 WELDERS - Receive rate prescribed for craft performing operation to which welding is incidental.
 =====

Note: Executive Order (EO) 13706, Establishing Paid Sick Leave for Federal Contractors applies to all contracts subject to the Davis-Bacon Act for which the contract is awarded (and any solicitation was issued) on or after January 1, 2017. If this contract is covered by the EO, the contractor must provide employees with 1 hour of paid sick leave for every 30 hours they work, up to 56 hours of paid sick leave each year.

Employees must be permitted to use paid sick leave for their own illness, injury or other health-related needs, including preventive care; to assist a family member (or person who is like family to the employee) who is ill, injured, or has other health-related needs, including preventive care; or for reasons resulting from, or to assist a family member (or person who is like family to the employee) who is a victim of, domestic violence, sexual assault, or stalking. Additional information on contractor requirements and worker protections under the EO is available at www.dol.gov/whd/govcontracts.

Unlisted classifications needed for work not included within the scope of the classifications listed may be added after award only as provided in the labor standards contract clauses (29CFR 5.5 (a) (1) (ii)).

The body of each wage determination lists the classification and wage rates that have been found to be prevailing for the cited type(s) of construction in the area covered by the wage determination. The classifications are listed in alphabetical order of "identifiers" that indicate whether the particular rate is a union rate (current union negotiated rate for local), a survey rate (weighted average rate) or a union average rate (weighted union average rate).

Union Rate Identifiers

A four letter classification abbreviation identifier enclosed in dotted lines beginning with characters other than "SU" or "UAVG" denotes that the union classification and rate were prevailing for that classification in the survey. Example: PLUM0198-005 07/01/2014. PLUM is an abbreviation identifier of the union which prevailed in the survey for this classification, which in this example would be Plumbers. 0198 indicates the local union number or district council number where applicable, i.e., Plumbers Local 0198. The next number, 005 in the example, is an internal number used in processing the wage determination. 07/01/2014 is the effective date of the most current negotiated rate, which in this example is July 1, 2014.

Union prevailing wage rates are updated to reflect all rate changes in the collective bargaining agreement (CBA) governing this classification and rate.

Survey Rate Identifiers

Classifications listed under the "SU" identifier indicate that no one rate prevailed for this classification in the survey and the published rate is derived by computing a weighted average rate based on all the rates reported in the survey for that classification. As this weighted average rate includes all rates reported in the survey, it may include both union and non-union rates. Example: SULA2012-007 5/13/2014. SU indicates the rates are survey rates based on a weighted average calculation of rates and are not majority rates. LA indicates the State of Louisiana. 2012 is the year of survey on which these classifications and rates are based. The next number, 007 in the example, is an internal number used in producing the wage determination. 5/13/2014 indicates the survey completion date for the classifications and rates under that identifier.

Survey wage rates are not updated and remain in effect until a new survey is conducted.

Union Average Rate Identifiers

Classification(s) listed under the UAVG identifier indicate that no single majority rate prevailed for those classifications; however, 100% of the data reported for the classifications was union data. EXAMPLE: UAVG-OH-0010 08/29/2014. UAVG indicates that the rate is a weighted union average rate. OH indicates the state. The next number, 0010 in the example, is an internal number used in producing the wage determination. 08/29/2014 indicates the survey completion date for the classifications and rates under that identifier.

A UAVG rate will be updated once a year, usually in January of each year, to reflect a weighted average of the current negotiated/CBA rate of the union locals from which the rate is based.

WAGE DETERMINATION APPEALS PROCESS

1.) Has there been an initial decision in the matter? This can be:

- * an existing published wage determination
- * a survey underlying a wage determination
- * a Wage and Hour Division letter setting forth a position on a wage determination matter
- * a conformance (additional classification and rate) ruling

On survey related matters, initial contact, including requests for summaries of surveys, should be with the Wage and Hour Regional Office for the area in which the survey was conducted because those Regional Offices have responsibility for the Davis-Bacon survey program. If the response from this initial contact is not satisfactory, then the process described in 2.) and 3.) should be followed.

With regard to any other matter not yet ripe for the formal process described here, initial contact should be with the Branch of Construction Wage Determinations. Write to:

Branch of Construction Wage Determinations
Wage and Hour Division
U.S. Department of Labor
200 Constitution Avenue, N.W.
Washington, DC 20210

2.) If the answer to the question in 1.) is yes, then an interested party (those affected by the action) can request review and reconsideration from the Wage and Hour Administrator (See 29 CFR Part 1.8 and 29 CFR Part 7). Write to:

Wage and Hour Administrator
U.S. Department of Labor
200 Constitution Avenue, N.W.
Washington, DC 20210

The request should be accompanied by a full statement of the interested party's position and by any information (wage payment data, project description, area practice material,

etc.) that the requestor considers relevant to the issue.

3.) If the decision of the Administrator is not favorable, an interested party may appeal directly to the Administrative Review Board (formerly the Wage Appeals Board). Write to:

Administrative Review Board
U.S. Department of Labor
200 Constitution Avenue, N.W.
Washington, DC 20210

4.) All decisions by the Administrative Review Board are final.

END OF GENERAL DECISION

END OF SECTION

PART VI
CONTRACT AGREEMENT

INDEX

1. SCOPE OF WORK
2. TIME OF COMPLETION
3. ISSUANCE OF WORK ORDERS
4. THE CONTRACT SUM
5. LIQUIDATED DAMAGES
6. PROGRESS PAYMENTS
7. ACCEPTANCE AND FINAL PAYMENT
8. THE CONTRACT DOCUMENTS
9. EXTRA WORK
10. ENUMERATION OF BID PROPOSAL AND DRAWINGS

PART VI

CONTRACT AGREEMENT

THIS AGREEMENT, made on the 30 day of August, 2018, by and between **Lexington-Fayette Urban County Government**, acting herein called "OWNER" and **L&M Partners Ltd dba ATS Construction**, doing business as a corporation located in the City of Lexington, County of Fayette, and State of Kentucky, hereinafter called "CONTRACTOR."

WITNESSETH: That the CONTRACTOR and the OWNER in consideration of two hundred fifty thousand one hundred three Dollars and seventy-five Cents (\$250,103.75) quoted in the proposal by the CONTRACTOR, dated August 7, 2018, hereby agree to commence and complete the construction described as follows:

1. SCOPE OF WORK

The CONTRACTOR shall furnish all the materials, supplies, machinery, equipment, tools, superintendence, labor, insurance, and other accessories and services necessary to complete the said project in accordance with the conditions and prices stated in the Proposal, the General Conditions, and the Special Conditions of the Contract, the Specifications and Contract Documents therefore as prepared by **GRW Engineers Inc** for the **Man O' War Boulevard Public Improvement Project Richmond Road Intersection**

2. TIME OF COMPLETION

The time period estimated and authorized by the OWNER for the proper execution of the Work by the Contract, in full, is hereby fixed as **ninety (90) calendar days**. The time shall begin ten (10) days after the CONTRACTOR is given the Notice to Proceed with the Work.

3. ISSUANCE OF WORK ORDERS

Notice to begin Work will be given in whole or for part of the Work as determined by the OWNER pending the availability of funds. The order of construction will be as determined by the Engineer after consultation with the CONTRACTOR and the OWNER.

4. THE CONTRACT SUM

The OWNER agrees to pay the CONTRACTOR in current funds for the performance of the Contract, as quoted in the proposal, subject to any additions and deductions, as provided therein.

5. LIQUIDATED DAMAGES

It is mutually agreed by and between the parties hereto that time is of the essence of this Contract, and that there will be sustained by the OWNER damages, monetary and otherwise, in the event of delay in the completion of the Work hereby contracted. The CONTRACTOR will be held responsible to the OWNER for delays in completion of the Work herein contracted beyond the date

set for completion. Such monetary damage shall be deducted from the Contract sum in the amount of SEVEN HUNDRED FIFTY DOLLARS (\$750.00) per calendar day of such delay. If the Work contracted to be done shall not, in good faith, be commenced at the time specified, then the CONTRACTOR together with the Surety or Sureties upon the bond herein provided for, shall be liable for and shall pay to the OWNER all damages sustained by reason of such failure for breach of Contract, and the OWNER may immediately re-let the Work involved.

6. PROGRESS PAYMENTS

The OWNER shall make payments on account of the Contract, as provided in accordance with the General Conditions, as estimated by the Engineer, less the aggregate of previous payments.

7. ACCEPTANCE AND FINAL PAYMENT

Final payment shall be due within ninety (90) days after completion of the Work, provided the Work be then fully completed and the Contract fully accepted.

Before issuance of final certificate, the CONTRACTOR shall submit evidence satisfactory to the Engineer that all payrolls, material bills, and other indebtedness connected with the Work has been paid.

If full completion of the Work is materially delayed through no fault of the CONTRACTOR, and the ENGINEER so certifies, the OWNER shall upon certificate of the ENGINEER, and without terminating the Contract, make payment of the balance due for that portion of the Work fully completed and accepted. Such payment shall be made under the terms and conditions governing final payment, except that it shall not constitute a waiver of claims.

8. THE CONTRACT DOCUMENTS

The Advertisement for Bids, Information for Bidders, the General Conditions, Performance and Payment Bonds, Contract Agreement, Special Conditions, General Provisions, any and all Addenda, and Bid Proposal, and Plan Drawings form the Contract, and they are fully a part of the Contract as if hereto attached or herein repeated.

9. EXTRA WORK

The OWNER, without invalidating the Contract, may order extra work or make changes by altering, adding to or deducting from the Work, the Contract Sum being adjusted accordingly. All such Work shall be executed and paid for in accordance with the General Conditions, which is a part of this Contract.

10. THE FOLLOWING IS AN ENUMERATION OF THE BID PROPOSAL AND DRAWINGS (CONTRACT DOCUMENTS):

CONTRACT DOCUMENTS

PART NO.	TITLE
I	Advertisement for Bids
II	Information for Bidders
III	Form of Proposal
IV	General Conditions
V	Special Conditions
VI	Contract Agreement
VII	Performance and Payment Bonds
VIII	Addendum
IX	Technical Specifications
Section A	General Provisions
Section B	Final Cleanup
Section 1	Mobilization and Demobilization
Section 2	Maintenance and Control of Traffic
Section 3	Staking
Section 4	Erosion Control
Section 5	Sawcutting Curb & Gutter and Asphalt Pavement
Section 6	Remove Asphalt Pavement, Concrete Curb & Gutter, Pipe, and Storm Structures
Section 7	Sidewalks
Section 8	(Not Used In This Contract)
Section 9	Excavation (Unclassified)
Section 10	No. 2 Stone
Section 11	Geotextile Construction
Section 12	Dense Graded Aggregate Base
Section 13	Standard Curb and Gutter Type 1 or 2
Section 14	Class A Concrete (Special Pavement Section)
Section 15	Edge Key
Section 16	Asphalt Concrete Base & Surface
Section 17	Asphalt Pavement Milling and Texturing
Section 18	Sodding
Section 19	(Not Used In This Contract)
Section 20	Light Pole Base
Section 21	Electrical Conduit for Lighting
Section 22	Conduit for Fiber-Optic Cable
Section 23	Adjust Valve or Manhole to Grade
Section 24	Pavement Markings

Section 25	Inlaid Pavement Markers
Section 26	Remove and Replace Fence
Section 27	Manhole Construction
Section 28	Curb and Drop Box Inlet
Section 29	(Not Used In This Contract)
Section 30	Storm Sewer Pipe

IN WITNESSETH WHEREOF, the parties hereto have executed this Contract as of the date and year above written.

(Seal)

Lexington-Fayette Urban County Government.

Lexington, Kentucky

(Owner)

ATTEST:

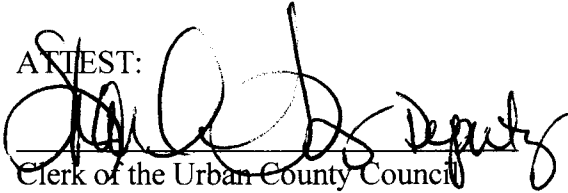
Deputy
Clerk of the Urban County Council

BY: _____

MAYOR

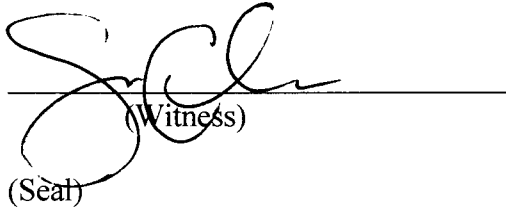

(Witness)
(Seal)

**L-M Asphalt Partners, Ltd.
dba ATS Construction**

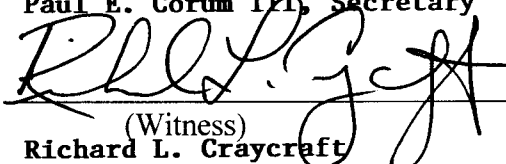
(Contractor)

(Secretary)*
Paul E. Corum III, Secretary

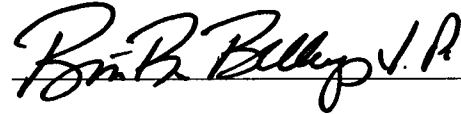
(Witness)
Richard L. Graycraft

BY: _____

V.P.

Brian R. Billings, Vice President

(Title)

**3009 Atkinson Avenue, Suite 400
Lexington, Kentucky 40509**

(Address and Zip Code)

IMPORTANT: *Strike out any non-applicable terms.

Secretary of the Owner should attest. If the CONTRACTOR is corporation, Secretary should attest. Give proper title of each person-executing Contract.

Payment Bond

CONTRACTOR (Name and Address):

L-M Asphalt Partners, Ltd.
dba ATS Construction
3009 Atkinson Ave., Ste. 400
Lexington, KY 40509

OWNER (Name and Address):

Lexington-Fayette Urban County Government
Division of Central Purchasing
200 East Main Street
Lexington, Kentucky 40507

CONSTRUCTION CONTRACT

Date: September 13, 2018

Amount: \$250,103.75

Description (Name and Location): Invitation to Bid #102-2018, Man O'War Boulevard Public Improvement Project, Richmond Road Intersection, Lexington, KY

BOND

Date (Not earlier than Construction Contract Date): September 13, 2018

Amount: \$250,103.75

Modifications to this Bond:

None

See Page 6

CONTRACTOR AS PRINCIPAL

Company: (Corporate Seal)
L-M Asphalt Partners, Ltd.
dba ATS Construction

Signature: 

Name and Title: Brian R. Billings
Vice President

SURETY

Company: (Corporate Seal)
Hartford Fire Insurance Company

Signature: 

Name and Title: Kim Watson Attorney-In-Fact

(Any additional signatures appear on page 6)

(FOR INFORMATION ONLY - Name, Address and Telephone)

AGENT or BROKER:

GCH Insurance Group
780 Winchester Road
Lexington, KY 40505
859-254-1836

OWNER'S REPRESENTATIVE (Architect, Engineer or other party):

GRW Engineers Inc.
801 Corporate Drive
Lexington, KY 40503
(859) 223-3999

1 The Contractor and the Surety, jointly and severally, bind themselves, their heirs, executors, administrators, successors and assigns to the Owner to pay for labor, materials and equipment furnished for use in the performance of the Construction Contract, which is incorporated herein by reference.

2 With respect to the Owner, this obligation shall be null and void if the Contractor:

2.1 Promptly makes payment, directly or indirectly, for all sums due Claimants, and

2.2 Defends, indemnifies and holds harmless the Owner from claims, demands, liens or suits by any person or entity whose claim, demand, lien or suit is for the payment for labor, materials or equipment furnished for use in the performance of the Construction Contract, provided the Owner has promptly notified the Contractor and the Surety (at the address described in Paragraph 12) of any claims, demands, liens or suits and tendered defense of such claims, demands, liens or suits to the Contractor and Surety, and provided there is no Owner Default.

3 With respect to Claimants, this obligation shall be null and void if the Contractor promptly makes payment, directly or indirectly, for all sums due.

4 The Surety shall have no obligation to Claimants under this Bond until:

4.1 Claimants who are employed by or have a direct contract with the Contractor have given notice to the Surety (at the address described in Paragraph 12) and sent a copy, or notice thereof, to the Owner, stating that a claim is being made under this Bond and, with substantial accuracy, the amount of the claim.

4.2. Claimants who do not have a direct contract with the Contractor:

.1 Have furnished written notice to the Contractor and sent a copy, or notice thereof, to the Owner, within 90 days after having last performed labor or last furnished materials or equipment included in the claim stating, with substantial accuracy, the amount of the claim and the name of the party to whom the materials were furnished or supplied or for whom the labor was done or performed; and

.2 Have either received a rejection in whole or in part from the Contractor, or not received within 30 days of furnishing the above notice any communication from the

Contractor by which the Contractor has indicated the claim will be paid directly or indirectly; and

.3 Not having been paid within the above 30 days, have sent a written notice to the Surety (at the address described in Paragraph 12) and sent a copy, or notice thereof, to the Owner, stating that a claim is being made under this Bond and enclosing a copy of the previous written notice furnished to the Contractor.

5 If a notice required by Paragraph 4 is given by the Owner to the Contractor or to the Surety, that is sufficient compliance.

6 When the Claimant has satisfied the conditions of Paragraph 4, the Surety shall promptly and at the Surety's expense take the following actions:

6.1 Send an answer to the Claimant, with a copy to the Owner, within 45 days after receipt of the claim, stating the amounts that are undisputed and the basis for challenging any amounts that are disputed.

6.2 Pay or arrange for payment of any undisputed amounts.

7 The Surety's total obligation shall not exceed the amount of this Bond, and the amount of this Bond shall be credited for any payments made in good faith by the Surety.

8 Amounts owed by the Owner to the Contractor under the Construction Contract shall be used for the performance of the Construction Contract and to satisfy claims, if any, under any Construction Performance Bond. By the Contractor furnishing and the Owner accepting this Bond, they agree that all funds earned by the Contractor in the performance of the Construction Contract are dedicated to satisfy obligations of the Contractor and the Surety under this Bond, subject to the Owner's priority to use the funds for the completion of the work.

9 The Surety shall not be liable to the Owner, Claimants or others for obligations of the Contractor that are unrelated to the Construction Contract. The Owner shall not be liable for payment of any costs or expenses of any Claimant under this Bond, and shall have under this Bond no obligations to make payments to, give notices on behalf of, or otherwise have obligations to Claimants under this Bond.

10 The Surety hereby waives notice of any change, including changes of time, to the Construction Contract

or to related subcontracts, purchase orders and other obligations.

11 No suit or action shall be commenced by a Claimant under this Bond other than in a court of competent jurisdiction in the location in which the work or part of the work is located or after the expiration of one year from the date (1) on which the Claimant gave the notice required by Subparagraph 4.1 or Clause 4.2.3, or (2) on which the last labor or service was performed by anyone or the last materials or equipment were furnished by anyone under the Construction Contract, whichever of (1) or (2) first occurs. If the provisions of this Paragraph are void or prohibited by law, the minimum period of limitation available to sureties as a defense in the jurisdiction of the suit shall be applicable.

12 Notice to the Surety, the Owner or the Contractor shall be mailed or delivered to the address shown on the signature page. Actual receipt of notice by Surety, the Owner or the Contractor, however accomplished, shall be sufficient compliance as of the date received at the address shown on the signature page.

13 When this Bond has been furnished to comply with a statutory or other legal requirement in the location where the construction was to be performed, any provision in this Bond conflicting with said statutory or legal requirement shall be deemed deleted herefrom and provisions conforming to such statutory or other legal requirement shall be deemed incorporated herein. The intent is that this Bond shall be construed as a

statutory bond and not as a common law bond.

14 Upon request by any person or entity appearing to be a potential beneficiary of this Bond, the Contractor shall promptly furnish a copy of this Bond or shall permit a copy to be made.

15 DEFINITIONS

15.1 Claimant: An individual or entity having a direct contract with the Contractor or with a subcontractor of the Contractor to furnish labor, materials or equipment for use in the performance of the Contract. The intent of this Bond shall be to include without limitation in the terms "labor, materials or equipment" that part of water, gas, power, light, heat, oil, gasoline, telephone service or rental equipment used in the Construction Contract, architectural and engineering services required for performance of the work of the Contractor and the Contractor's subcontractors, and all other items for which a mechanic's lien may be asserted in the jurisdiction where the labor, materials or equipment were furnished.

15.2 Construction Contract: The agreement between the Owner and the Contractor identified on the signature page, including all Contract Documents and changes thereto.

15.3 Owner Default: Failure of the Owner, which has neither been remedied nor waived, to pay the Contractor as required by the Construction Contract or to perform and complete or comply with the other terms thereof.

MODIFICATIONS TO THIS BOND ARE AS FOLLOWS:

(Space is provided below for additional signatures of added parties, other than those appearing on the cover page.)

CONTRACTOR AS PRINCIPAL
Company:

(Corporate Seal)

SURETY
Company:

(Corporate Seal)

Signature: _____
Name and Title:
Address:

Signature: _____
Name and Title:
Address:

POWER OF ATTORNEY

Direct Inquiries/Claims to:

THE HARTFORD

BOND, T-4

One Hartford Plaza

Hartford, Connecticut 06155

call: 888-266-3488 or fax: 860-757-5835

Agency Code: 33-751009 & 14-732421

KNOW ALL PERSONS BY THESE PRESENTS THAT:

- Hartford Fire Insurance Company, a corporation duly organized under the laws of the State of Connecticut
- Hartford Casualty Insurance Company, a corporation duly organized under the laws of the State of Indiana
- Hartford Accident and Indemnity Company, a corporation duly organized under the laws of the State of Connecticut
- Hartford Underwriters Insurance Company, a corporation duly organized under the laws of the State of Connecticut
- Twin City Fire Insurance Company, a corporation duly organized under the laws of the State of Indiana
- Hartford Insurance Company of Illinois, a corporation duly organized under the laws of the State of Illinois
- Hartford Insurance Company of the Midwest, a corporation duly organized under the laws of the State of Indiana
- Hartford Insurance Company of the Southeast, a corporation duly organized under the laws of the State of Florida

having their home office in Hartford, Connecticut, (hereinafter collectively referred to as the "Companies") do hereby make, constitute and appoint, **up to the amount of unlimited:**

Russell Griffith, David Henry, Jerry Catlett, Kim Watson, Betty Royalty, John W. Hampton, Tina Carpenter
of
Lexington, KY

their true and lawful Attorney(s)-in-Fact, each in their separate capacity if more than one is named above, to sign its name as surety(ies) only as delineated above by , and to execute, seal and acknowledge any and all bonds, undertakings, contracts and other written instruments in the nature thereof, on behalf of the Companies in their business of guaranteeing the fidelity of persons, guaranteeing the performance of contracts and executing or guaranteeing bonds and undertakings required or permitted in any actions or proceedings allowed by law.

In Witness Whereof, and as authorized by a Resolution of the Board of Directors of the Companies on August 1, 2009 the Companies have caused these presents to be signed by its Vice President and its corporate seals to be hereto affixed, duly attested by its Assistant Secretary. Further, pursuant to Resolution of the Board of Directors of the Companies, the Companies hereby unambiguously affirm that they are and will be bound by any mechanically applied signatures applied to this Power of Attorney.



Wesley W. Cowling

Wesley W. Cowling, Assistant Secretary

M. Ross Fisher

M. Ross Fisher, Vice President

STATE OF CONNECTICUT }
COUNTY OF HARTFORD } ss. Hartford

On this 12th day of July, 2012, before me personally came M. Ross Fisher, to me known, who being by me duly sworn, did depose and say: that he resides in the County of Hartford, State of Connecticut; that he is the Vice President of the Companies, the corporations described in and which executed the above instrument; that he knows the seals of the said corporations; that the seals affixed to the said instrument are such corporate seals; that they were so affixed by authority of the Boards of Directors of said corporations and that he signed his name thereto by like authority.



CERTIFICATE

Kathleen T. Maynard

Kathleen T. Maynard
Notary Public

My Commission Expires July 31, 2016

I, the undersigned, Vice President of the Companies, DO HEREBY CERTIFY that the above and foregoing is a true and correct copy of the Power of Attorney executed by said Companies, which is still in full force effective as of September 13, 2018 .

Signed and sealed at the City of Hartford.



Gary W. Stumper

Gary W. Stumper, Vice President

Performance Bond

CONTRACTOR (Name and Address):

L-M Asphalt Partners, Ltd.
dba ATS Construction
3009 Atkinson Ave., Ste. 400
Lexington, KY 40509

SURETY (Name and Principal Place of Business):

Hartford Fire Insurance Company
One Hartford Plaza, T-4-47
Hartford, CT 06155

OWNER (Name and Address):

Lexington-Fayette Urban County Government
Division of Central Purchasing
200 East Main Street
Lexington, Kentucky 40507

CONSTRUCTION CONTRACT

Date: September 13, 2018

Amount: \$250,103.75

Description (Name and Location): Invitation to Bid #102-2018, Man O'War Boulevard Public Improvement Project, Richmond Road Intersection, Lexington, KY

BOND

Date (Not earlier than Construction Contract Date): September 13, 2018

Amount: \$250,103.75

Modifications to this Bond:

None

See Page 3

CONTRACTOR AS PRINCIPAL

Company: (Corporate Seal)
L-M Asphalt Partners, Ltd.

dba ATS Construction

Signature: Brian R. Billings

Name and Title: Brian R. Billings
Vice President

SURETY

Company: (Corporate Seal)
Hartford Fire Insurance Company

Signature: Kim Watson

Name and Title: Kim Watson Attorney-In-Fact

(Any additional signatures appear on page 3)

(FOR INFORMATION ONLY - Name, Address and Telephone)

AGENT or BROKER:

GCH Insurance Group
780 Winchester Road
Lexington, KY 40505
859-254-1836

OWNER'S REPRESENTATIVE (Architect, Engineer or other party):

GRW Engineers Inc.
801 Corporate Drive
Lexington, KY 40503
(859) 223-3999

1 The Contractor and the Surety, jointly and severally, bind themselves, their heirs, executors, administrators, successors and assigns to the Owner for the performance of the Construction Contract, which is incorporated herein by reference.

2 If the Contractor performs the Construction Contract, the Surety and the Contractor shall have no obligation under this Bond, except to participate in conferences as provided in Subparagraph 3.1.

3 If there is no Owner Default, the Surety's obligation under this Bond shall arise after:

3.1 The Owner has notified the Contractor and the Surety at its address described in Paragraph 10 below that the Owner is considering declaring a Contractor Default and has requested and attempted to arrange a conference with the Contractor and the Surety to be held not later than fifteen days after receipt of such notice to discuss methods of performing the Construction Contract. If the Owner, the Contractor and the Surety agree, the Contractor shall be allowed a reasonable time to perform the Construction Contract, but such an agreement shall not waive the Owner's right, if any, subsequently to declare a Contractor Default; and

3.2 The Owner has declared a Contractor Default and formally terminated the Contractor's right to complete the contract. Such Contractor Default shall not be declared earlier than twenty days after the Contractor and the Surety have received notice as provided in Subparagraph 3.1; and

3.3 The Owner has agreed to pay the Balance of the Contract Price to the Surety in accordance with the terms of the Construction Contract or to a contractor selected to perform the Construction Contract in accordance with the terms of the contract with the Owner.

4 When the Owner has satisfied the conditions of Paragraph 3, the Surety shall promptly and at the Surety's expense take one of the following actions:

4.1 Arrange for the Contractor, with consent of the Owner, to perform and complete the Construction Contract; or

4.2 Undertake to perform and complete the Construction Contract itself, through its agents or through independent contractors; or

4.3 Obtain bids or negotiated proposals from qualified contractors acceptable to the Owner for a contract for performance and completion of the Construction Contract, arrange for a contract to be

prepared for execution by the Owner and the contractor selected with the Owner's concurrence, to be secured with performance and payment bonds, executed by a qualified surety equivalent to the bonds issued on the Construction Contract, and pay to the Owner the amount of damages as described in Paragraph 6 in excess of the Balance of the Contract Price incurred by the Owner resulting from the Contractor's default; or

4.4 Waive its right to perform and complete, arrange for completion, or obtain a new contractor and with reasonable promptness under the circumstances:

.1 After investigation, determine the amount for which it may be liable to the Owner and, as soon as practicable after the amount is determined, tender payment therefor to the Owner; or

.2 Deny liability in whole or in part and notify the Owner citing reasons therefor.

5 If the Surety does not proceed as provided in Paragraph 4 with reasonable promptness, the Surety shall be deemed to be in default on this Bond fifteen days after receipt of an additional written notice from the Owner to the Surety demanding that the Surety perform its obligations under this Bond, and the Owner shall be entitled to enforce any remedy available to the Owner. If the Surety proceeds as provided in Subparagraph 4.4, and the Owner refuses the payment tendered or the Surety has denied liability, in whole or in part, without further notice the Owner shall be entitled to enforce any remedy available to the Owner.

6 After the Owner has terminated the Contractor's right to complete the Construction Contract, and if the Surety elects to act under Subparagraph 4.1, 4.2, or 4.3 above, then the responsibilities of the Surety to the Owner shall not be greater than those of the Contractor under the Construction Contract, and the responsibilities of the Owner to the Surety shall not be greater than those of the Owner under the Construction Contract. To the limit of the amount of this bond, but subject to commitment by the Owner of the Balance of the Contract Price to mitigation of costs and damages on the Construction Contract, the Surety is obligated without duplication for:

6.1 The responsibilities of the Contractor for correction of defective work and completion of the Construction Contract;

6.2 Additional legal, design professional and delay costs resulting from the Contractor's Default, and

resulting from the actions or failure to act of the Surety under Paragraph 4; and

6.3 Liquidated damages, or if no liquidated damages are specified in the Construction Contract, actual damages caused by delayed performance or non-performance of the Contractor.

7 The Surety shall not be liable to the Owner or others for obligations of the Contractor that are unrelated to the Construction Contract, and the Balance of the Contract Price shall not be reduced or set off on account of any such unrelated obligations. No right of action shall accrue on this Bond to any person or entity other than the Owner or its heirs, executors, administrators or successors.

8 The Surety hereby waives notice of any change, including changes of time, to the Construction Contract or to related subcontracts, purchase orders and other obligations.

9 Any proceeding, legal or equitable, under this Bond may be instituted in any court of competent jurisdiction in the location in which the work or part of the work is located and shall be instituted within two years after Contractor Default or within two years after the Contractor ceased working or within two years after the Surety refuses or fails to perform its obligations under this Bond, whichever occurs first. If the provisions of this Paragraph are void or prohibited by law, the minimum period of limitation available to sureties as a defense in the jurisdiction of the suit shall be applicable.

10 Notice to the Surety, the Owner or the Contractor shall be mailed or delivered to the address shown on the signature page.

11 When this Bond has been furnished to comply with

a statutory or other legal requirement in the location where the construction was to be performed, any provision in this Bond conflicting with said statutory or legal requirement shall be deemed deleted herefrom and provisions conforming to such statutory or other legal requirement shall be deemed incorporated herein. The intent is that this Bond shall be construed as a statutory bond and not as a common law bond.

12 DEFINITIONS

12.1 Balance of the Contract Price: The total amount payable by the Owner to the Contractor under the Construction Contract after all proper adjustments have been made, including allowance to the Contractor of any amounts received or to be received by the Owner in settlement of insurance or other claims for damages to which the Contractor is entitled, reduced by all valid and proper payments made to or on behalf of the Contractor under the Construction Contract.

12.2 Construction Contract: The agreement between the Owner and the Contractor identified on the signature page, including all Contract Documents and changes thereto.

12.3 Contractor Default: Failure of the Contractor, which has neither been remedied nor waived, to perform or otherwise to comply with the terms of the Construction Contract.

12.4 Owner Default: Failure of the Owner, which has neither been remedied nor waived, to pay the Contractor as required by the Construction Contract or to perform and complete or comply with the other terms thereof.

MODIFICATIONS TO THIS BOND ARE AS FOLLOWS:

(Space is provided below for additional signatures of added parties, other than those appearing on the cover page.)

CONTRACTOR AS PRINCIPAL
Company: _____ (Corporate Seal)

SURETY
Company: _____ (Corporate Seal)

Signature: _____
Name and Title:
Address: _____

Signature: _____
Name and Title:
Address: _____

POWER OF ATTORNEY

Direct Inquiries/Claims to:

THE HARTFORD

BOND, T-4

One Hartford Plaza

Hartford, Connecticut 06155

call: 888-266-3488 or fax: 860-757-5835

Agency Code: 33-751009 & 14-732421

KNOW ALL PERSONS BY THESE PRESENTS THAT:

- Hartford Fire Insurance Company**, a corporation duly organized under the laws of the State of Connecticut
- Hartford Casualty Insurance Company**, a corporation duly organized under the laws of the State of Indiana
- Hartford Accident and Indemnity Company**, a corporation duly organized under the laws of the State of Connecticut
- Hartford Underwriters Insurance Company**, a corporation duly organized under the laws of the State of Connecticut
- Twin City Fire Insurance Company**, a corporation duly organized under the laws of the State of Indiana
- Hartford Insurance Company of Illinois**, a corporation duly organized under the laws of the State of Illinois
- Hartford Insurance Company of the Midwest**, a corporation duly organized under the laws of the State of Indiana
- Hartford Insurance Company of the Southeast**, a corporation duly organized under the laws of the State of Florida

having their home office in Hartford, Connecticut, (hereinafter collectively referred to as the "Companies") do hereby make, constitute and appoint, **up to the amount of unlimited:**

Russell Griffith, David Henry, Jerry Catlett, Kim Watson, Betty Royalty, John W. Hampton, Tina Carpenter
of
Lexington, KY

their true and lawful Attorney(s)-in-Fact, each in their separate capacity if more than one is named above, to sign its name as surety(ies) only as delineated above by , and to execute, seal and acknowledge any and all bonds, undertakings, contracts and other written instruments in the nature thereof, on behalf of the Companies in their business of guaranteeing the fidelity of persons, guaranteeing the performance of contracts and executing or guaranteeing bonds and undertakings required or permitted in any actions or proceedings allowed by law.

In Witness Whereof, and as authorized by a Resolution of the Board of Directors of the Companies on August 1, 2009 the Companies have caused these presents to be signed by its Vice President and its corporate seals to be hereto affixed, duly attested by its Assistant Secretary. Further, pursuant to Resolution of the Board of Directors of the Companies, the Companies hereby unambiguously affirm that they are and will be bound by any mechanically applied signatures applied to this Power of Attorney.



Wesley W. Cowling

Wesley W. Cowling, Assistant Secretary

M. Ross Fisher

M. Ross Fisher, Vice President

STATE OF CONNECTICUT }
COUNTY OF HARTFORD } ss. Hartford

On this 12th day of July, 2012, before me personally came M. Ross Fisher, to me known, who being by me duly sworn, did depose and say: that he resides in the County of Hartford, State of Connecticut; that he is the Vice President of the Companies, the corporations described in and which executed the above instrument; that he knows the seals of the said corporations; that the seals affixed to the said instrument are such corporate seals; that they were so affixed by authority of the Boards of Directors of said corporations and that he signed his name thereto by like authority.



CERTIFICATE

Kathleen T. Maynard

Kathleen T. Maynard
Notary Public

My Commission Expires July 31, 2016

I, the undersigned, Vice President of the Companies, DO HEREBY CERTIFY that the above and foregoing is a true and correct copy of the Power of Attorney executed by said Companies, which is still in full force effective as of September 13, 2018 .

Signed and sealed at the City of Hartford.



Gary W. Stumper

Gary W. Stumper, Vice President

PART IV
TECHNICAL SPECIFICATIONS

Table of Contents

Section A	General Provisions
Section B	Final Cleanup
Section 1	Mobilization and Demobilization
Section 2	Maintenance and Control of Traffic
Section 3	Staking
Section 4	Erosion Control
Section 5	Sawcutting Curb & Gutter and Asphalt Pavement
Section 6	Remove Asphalt Pavement, Concrete Curb & Gutter, Pipe, and Storm Structures
Section 7	Sidewalks
Section 8	(Not Used In This Contract)
Section 9	Excavation (Unclassified)
Section 10	No. 2 Stone
Section 11	Geotextile Construction
Section 12	Dense Graded Aggregate Base
Section 13	Standard Curb and Gutter Type 1 or 2
Section 14	Class A Concrete (Special Pavement Section)
Section 15	Edge Key
Section 16	Asphalt Concrete Base & Surface
Section 17	Asphalt Pavement Milling and Texturing
Section 18	Sodding
Section 19	(Not Used In This Contract)
Section 20	Light Pole Base
Section 21	Electrical Conduit for Lighting
Section 22	Conduit for Fiber-Optic Cable
Section 23	Adjust Valve or Manhole to Grade
Section 24	Pavement Markings
Section 25	Inlaid Pavement Markers
Section 26	Remove and Replace Fence
Section 27	Manhole Construction
Section 28	Curb and Drop Box Inlet
Section 29	(Not Used In This Contract)
Section 30	Storm Sewer Pipe

TECHNICAL SPECIFICATIONS

SECTION A - GENERAL PROVISIONS

A.1 KENTUCKY DEPARTMENT OF HIGHWAYS - SPECIFICATIONS

Except as otherwise indicated on the Plans, and in the Contract Documents and Specifications, all items of Work including materials, construction methods, method of measurement and basis of payment shall comply with the current edition of the *Kentucky Department of Highways (KDOH) Standard Specifications for Road and Bridge Construction* and all current revisions.

With regard to the incorporation *Standard Specifications of KDOH* into these Technical Specifications, the following should be noted:

- Unless either the content implicitly or the Plans and Contract Documents and Specifications explicitly indicate otherwise, all KDOH references to "the Department" should be construed as being references to the Lexington-Fayette Urban County Government (LFUCG).
- Any discrepancy between the *Standard Specifications of KDOH* and the express intentions of Lexington-Fayette Urban County Government (i.e., Plans, Contract Documents and Specifications, and Lexington-Fayette Urban County Government Standard Drawings) shall be resolved in favor of the latter. (An example of one of the more common types of discrepancy is that which sometimes occurs with regard to the measurement of and payment for Work items.)

A.2 ABBREVIATIONS

Abbreviations of standards, codes, and publications used within these Specifications are as follows:

ASTM	American Society of Testing and Materials
ANSI	American National Standard Institute
KDOH	Kentucky Department of Highways, "Standard Specifications for Road and Bridge Construction", Current Edition

A.3 SCOPE

It is the intent that the CONTRACTOR, in accordance with the Plans, Contract Documents and Specifications, and other mutually acknowledged informational materials shall perform everything required to be performed and to furnish a complete, fully operating Work, and shall provide and furnish all labor, materials, necessary tools, expendable and non-expendable equipment and all transportation services required for the entire, proper completion of the Work, the cost of all of which shall be included in his bid.

The CONTRACTOR shall make all requisite excavations and foundation preparation for constructing sidewalks, incidental drainage structures, and retaining walls. The

CONTRACTOR shall, where required, excavate and prepare subgrade for pavement widening and replacement. The CONTRACTOR shall provide all signs, lighting, barricades, flagmen and watchmen, and make provisions necessary to protect and maintain buildings, fences, trees, shrubs, poles, existing utility fixtures, watercourses, surface drains, or other structures in, on, across, or adjacent to the Work and repair all damage done to them where and as required. The CONTRACTOR shall perform all backfilling, restore walks, grass plots, flowers, shrubs, trees, paved surfaces, etc., damaged or disturbed and clear away all rubbish and surplus materials. The CONTRACTOR shall put in complete and acceptable working order the items covered by the Contract.

This Specification sets forth several items of Work or conditions which are required as integral parts of the successful completion of the Project. All items discussed herein under General Provisions are considered incidental to the overall accomplishment of the Project and no separate payment shall be made therefore unless otherwise noted elsewhere in these specifications.

A.4 CONTRACTOR'S FACILITIES

A.4.1 Sanitary Facilities: The CONTRACTOR shall provide and maintain all necessary sanitary facilities at the site, in accordance with all applicable regulations, and shall properly remove same at completion of the Project.

A.4.2 Utilities: The obtaining of all utilities which may be required for construction shall be the responsibility of the CONTRACTOR.

A.5 CONTRACTOR'S FIELD OFFICE

A CONTRACTOR'S Field Office is not required for this project.

A.6 UTILITIES

The CONTRACTOR is to notify all utility companies prior to beginning construction operations.

It shall be the CONTRACTOR'S responsibility to locate all utilities, make appropriate arrangements regarding relocation, maintain utility service throughout the construction period, and make final relocations at the completion of the Work. The CONTRACTOR shall be responsible for any injury or damage to the existing utilities due to his operations whether shown or not shown in the plans. Where utilities are shown or indicated on the plans, the information given is in accordance with the best information in possession of the OWNER but is approximate only. The data is not warranted to be either complete or correct, and the CONTRACTOR shall assume all risks resulting from the conditions arising from the approximations shown.

The CONTRACTOR shall confer with the utility companies to inform them of the proposed construction schedule, verify the location and elevation of existing utilities and arrange for the relocation and adjustment of any facilities to avoid interference with the proposed

construction. All such activities are to be performed under the direction of and with the approval of the ENGINEER.

When the various utility owners find it necessary to make adjustments to their lines where the CONTRACTOR is presently working, the CONTRACTOR is to move his operations to another area of Work so as not to interfere in any way with the utility company's Work.

Any utilities covered up or lost by the construction operations of the CONTRACTOR shall be uncovered and found by the CONTRACTOR and the new construction repaired and/or replaced as directed by the ENGINEER. No additional compensation will be allowed for such Work nor shall any additional payment be allowed for the relocation and adjusting of any utility but shall be considered Incidentals to other Work.

The CONTRACTOR shall make a concerted effort to prevent any disruption of utility services, and if an unintended disruption occurs, the CONTRACTOR shall immediately and safely restore service. If disruption of any of the utility services covered in this section is unavoidable, it will be the responsibility of the CONTRACTOR to notify affected property owners. The CONTRACTOR shall also make every effort to restore said services before quitting Work for the day. In the event this cannot be done, the CONTRACTOR shall provide temporary service to the property owners until permanent service can be restored.

A.7 TESTING

From time to time during the progress of the Work, the ENGINEER may require that testing be performed to determine the materials provided meet the specified requirements. The Lexington-Fayette Urban County Government will select a testing laboratory to perform the testing services. The cost of such services shall be the responsibility of the OWNER. If testing reveals defective materials or Work, the cost of said testing will become the responsibility of the CONTRACTOR.

A.7.1 Codes and Standards: Testing, when required, will be in accordance with all pertinent codes and regulations and with selected standards of the American Society for Testing and Materials.

A.7.2 Cooperation with the Testing Laboratory: Representatives of the testing laboratory shall have ready access to the Work at all times. The CONTRACTOR shall provide facilities for such access in order that the laboratory may properly perform its functions.

A.8 INSTALLATION REQUIREMENTS

Manufactured articles, materials and equipment shall be applied, installed, connected, erected, used, cleaned, and conditioned as suggested by the respective manufacturers, unless otherwise specified herein or directed by the ENGINEER.

A.9 PROOF OF COMPLIANCE

Whenever the Contract Documents require that a product be in accordance with Federal Specifications, ASTM Designations, ANSI Specifications, or other associations' standards, the CONTRACTOR shall present a certification from the manufacturer that the product complies therewith. When requested or specified, the CONTRACTOR shall submit supporting test data to substantiate compliance.

A.10 DUST CONTROL

The CONTRACTOR shall be responsible for minimizing the generation of dust resulting from his operations at all times. The CONTRACTOR shall be required to maintain all excavations, embankments, stockpiles, roads, permanent access roads, plant sites, waste areas, and all other Work areas within or without the project boundaries free from dust which would cause a hazard or nuisance to others. Approved temporary methods of stabilization consisting of sprinkling, chemical treatment, light bituminous treatment, or similar methods will be permitted to control dust. Dust control shall be performed as the Work proceeds, and whenever a dust nuisance or hazard occurs.

A.11 REPAIR OF DAMAGE

Any damage done to structures, fills, roadways, or other areas shall be repaired at the CONTRACTOR'S expense before final payment is made.

A.12 PROJECT EXTENT

The CONTRACTOR shall be responsible for satisfying himself as to the construction limits for the Project. The CONTRACTOR shall not establish Work, storage, or staging area outside the Project limits, unless otherwise directed or approved by the ENGINEER.

A.13 GUARANTEE

The CONTRACTOR shall assume responsibility for all workmanship and materials for a period of one year from final payment. Any Work found to be defective due to failure to comply with the provision and intent of the Contract Documents, Specifications, and Plans shall be replaced at the CONTRACTOR'S expense.

A.14 PROPERTY CONSIDERATION

Materials having a salvage value shall remain the property of the OWNER. Salvageable material rejected by the OWNER shall become the responsibility of the CONTRACTOR to dispose of in a proper manner subject to the approval of the ENGINEER.

A.15 BLASTING

Blasting is not permitted on this project.

A.16 HAZARDOUS MATERIAL - GAS LINES

The CONTRACTOR is advised to exercise caution in his operations on this project, regardless of whether the plans indicate or do not indicate the presence of any gas or hazardous materials carrying lines.

A.17 DIVERSION OF STORM WATER

Appropriate measures must be taken to sandbag the necessary manholes and to pump drainage around the area under construction. The CONTRACTOR is responsible for developing a plan to divert storm drainage around the construction area with the approval from the ENGINEER. Materials, labor, and all incidentals necessary to accomplish this diversion of storm drainage will be considered incidental to the contract.

A.18 SEWER SERVICE MAINTENANCE

This Work shall consist of maintaining existing sanitary sewer service to residents in the area during construction. Sewage is to be maintained by whatever means necessary. No surcharge of manholes will be allowed.

No separate payment will be made for Sewer Service Maintenance. Sewer Service Maintenance shall include all materials, equipment and labor necessary to maintain sewer service to residents during construction.

TECHNICAL SPECIFICATIONS

SECTION B - FINAL CLEANUP

B.1 SCOPE

The Work will not be considered as complete until the right-of-way and all ground occupied by the CONTRACTOR in connection with the Work has been cleared of all rubbish, equipment, excess materials, temporary structures, and weeds. Rubbish and all waste materials of whatever nature shall be disposed of in waste areas provided by the CONTRACTOR. All property, both public and private, which has been disturbed or damaged in the execution of the Work, shall be replaced or restored in an acceptable manner. All ditches shall be drained and all space shall be left unobstructed and in such condition as acceptable to the ENGINEER. Failure to implement any of these final cleanup elements by the contract completion date will engage the liquidated damages provision of the contract. The only exception thereto is for completion of seasonally sensitive work items, such as planting of certain landscaping materials or paint application, for which the OWNER has granted a time extension, in writing.

B.2 BASIS OF PAYMENT

No direct payment will be made for final cleanup.

TECHNICAL SPECIFICATIONS

SECTION 1 - MOBILIZATION AND DEMOBILIZATION

1.1 SCOPE

Work for this Section shall include all labor, excavation, materials, equipment, and incidentals necessary to mobilize and demobilize all personnel, equipment, supplies, and incidentals to the project site; to establish offices, buildings, and other facilities, that are necessary for performing the work; to accomplish all other work or operations that must be performed, including costs that must be incurred, to begin work on the project in accordance with the Kentucky Department of Highway Standard Specifications, Section 110.

1.2 MOBILIZATION

The Contractor shall not bid an amount for Mobilization that exceeds 5 percent of the sum of the total amounts bid for all other items in the Bid Proposal, excluding Mobilization, Demobilization, and contingent amounts established for adjustments and incentives, if applicable. The LFUCG will automatically adjust any bids in excess of this amount for bid comparisons. The LFUCG will base the award on the maximum allowable bid of 5 percent. If any errors in unit bid prices for other Contract items in a Contractor's Bid Proposal are discovered after bid opening and such errors reduce the total amount bid for all other items, excluding Mobilization, Demobilization, and contingent amounts established for adjustments and incentives, so that the percent bid for mobilization is larger than 5 percent, the LFUCG will adjust the amount bid for mobilization to 5 percent of the sum of the corrected total bid amounts.

1.3 PERFORMANCE AND PAYMENT BONDS

There shall be no adjustment for the Contractor's internal cost for personnel or staff in obtaining Payment/Performance Bonds, or for any other cost related to bonding. If such cost are not determined at the time the project is bid, the Contractor shall use his best estimate of such cost after consulting with his bond agent.

1.4 DEMOBILIZATION

The Contractor shall not bid an amount for Demobilization that is less than 1.5 percent of the sum of the total amounts bid for all other items in the Bid Proposal, excluding Mobilization, Demobilization, and contingent amounts established for adjustments and incentives, if applicable. The LFUCG will automatically adjust any bids that are less than this amount up to 1.5 percent to compare Bid Proposals and award the Contract. The LFUCG will award a Contract for the actual amount bid when the amount bid for demobilization exceeds 1.5 percent, or the LFUCG will award the Contract for the adjusted bid amount when the amount bid for demobilization is less than 1.5 percent.

1.5 BASIS OF PAYMENT

Mobilization is included in the Bid Proposal as a separate bid item and the LFUCG will make partial payment for Mobilization in two equal or approximately equal payments. The LFUCG will make the first payment on the first pay estimate on which the Contractor's total earned value on Contract items, other than Mobilization, exceeds \$1,000. The LFUCG will make the second payment on the first pay estimate on which the Contractor has earned 5 percent or more of the total Contract amount for Contract items, other than Mobilization. The LFUCG will make both payments simultaneously when these requirements are met at the same time.

Demobilization is included in the Bid Proposal as a separate bid item, the LFUCG will pay for Demobilization according to the following schedule:

- 1) 25 percent upon formal acceptance of the project.
- 2) 50 percent when the final estimate is submitted to the ENGINEER.
- 3) 25 percent when the final estimate is paid.

TECHNICAL SPECIFICATIONS

SECTION 2 – MAINTENANCE AND CONTROL OF TRAFFIC

2.1 SCOPE

The CONTRACTOR shall maintain all local vehicular and pedestrian traffic along the project during construction. The CONTRACTOR shall present a plan for maintenance of traffic, detours and traffic signs subject to the approval of the Lexington-Fayette Urban County Government (LFUCG) Traffic Engineer prior to the beginning of Work.

All work shall be performed in accordance with AASHTO Manual of Uniform Traffic Control Devices, latest edition, LFUCG permit requirements, and KYTC Standard Specifications referenced below.

To the extent that it does not conflict with the content of the Plans, Contract Documents, and Specifications, Subsection 112 of KDOH Standard Specifications, current edition, is incorporated into this Technical Specification.

2.2 MATERIALS

The CONTRACTOR shall furnish bridging plates or provide other means of maintaining safe access for pedestrians and service traffic to all businesses during normal working hours. Adequate personnel shall be available during daylight hours to assure maintenance. Metal trench covers, granular backfill or other suitable methods shall be utilized to maintain vehicular traffic through areas disturbed by construction operations.

2.3 SIGNING

The CONTRACTOR shall furnish and erect suitable barricades, signs and other necessary devices to control, guide and safeguard traffic passing through or around the construction project. All such devices shall conform in all respects to the requirements of the Manual on Uniform Traffic Control Devices for Highway Construction and Maintenance Projects. The CONTRACTOR, before erecting any barricades or changing the location of one already placed, shall notify the ENGINEER at least three days prior to such contemplated erection or change, except in case of an emergency. In case of an emergency, the ENGINEER may direct the CONTRACTOR to immediately provide safety and warning devices to safeguard traffic. All night-time control devices requiring illumination shall be lighted every night during the entire period from sunset to sunrise. The CONTRACTOR will be held responsible for all damage to Work due to failure to provide barricades, signs, lights, and watchmen to protect it; and whenever evidence of such damage is found prior to acceptance, the ENGINEER may order the damaged portion removed and replaced by the CONTRACTOR at the CONTRACTOR'S expense. The responsibility remains the CONTRACTOR'S until the project is accepted.

The Work shall also include the removal and relocation of any existing signage required for the project and a portable changeable message sign.

2.4 BASIS OF PAYMENT

Payment will be included in the Maintenance and Control of Traffic item of the bid and shall be per lump sum.

TECHNICAL SPECIFICATION

SECTION 3 - STAKING

3.1 SCOPE

The CONTRACTOR will furnish and be responsible for all staking, including the initial staking. The CONTRACTOR shall bear the cost of all staking necessary to control and complete the Work according to the specifications to the lines and grades shown on the plans.

It will be the CONTRACTOR'S responsibility to establish all office projection centerlines shown on the plans. Should, during the course of construction of this project, any construction stakes be destroyed by others, it will be the CONTRACTOR'S responsibility to reset the stakes at no additional cost to the OWNER.

The CONTRACTOR'S staking party shall be under the general supervision of a Licensed Land Surveyor. It shall be definitely understood that supervision of the resetting of construction staking is solely the responsibility of the CONTRACTOR and any errors or inaccuracies resulting from the operations of the construction staking party shall be corrected at no cost to the OWNER.

It will be the OWNER'S responsibility to make all measurements for determining final quantities to be used for basis of final payment on items of Work.

To the extent that it does not conflict with the content of the Plans and Contract Documents and Specifications, Section 201 of KDOH Standard Specifications, current edition, is incorporated into this technical specification.

3.1 BASIS OF PAYMENT

Payment for Staking shall be by lump sum.

TECHNICAL SPECIFICATION

SECTION 4 – EROSION CONTROL

4.1 SCOPE

- A. Furnish all labor, materials, and equipment required for erecting, maintaining and removing temporary erosion and sedimentation controls as shown on the Drawings and as specified herein and as recommended by state and local regulatory agencies.
- B. Work in this section shall conform to Section 212 and 213 of the KDOH Standard Specifications.
- C. The contractor shall at all times minimize disturbance and the period of time that the disturbed area is exposed without stabilization practices.
- D. Temporary erosion controls include, but are not limited to grassing, mulching, seeding, providing erosion control and turf reinforcement mats on all disturbed surfaces including waste area surfaces and stockpile and borrow area surfaces; scheduling work to minimize erosion and providing interceptor ditches at those locations which will ensure that erosion during construction will be either eliminated or maintained within acceptable limits.
- E. Temporary sedimentation controls include, but are not limited to, silt dams, traps, barriers, and appurtenances on sloped surfaces which will ensure that sedimentation pollution will be either eliminated or maintained within acceptable limits.
- F. Contractor is responsible for providing and maintaining effective temporary erosion and sediment control measures prior to and during construction or until final controls become effective.
- G. The Contractor shall be responsible for placement of erosion and sedimentation controls. If during the course of construction, the state and/or local regulatory agency determines additional controls are required, the Contractor shall furnish, install and maintain additional mulching, blankets and/or sediment barriers to control erosion and sedimentation to the satisfaction of the regulatory agency.
- H. The Contractor shall inspect and repair all erosion and sedimentation controls every seven (7) days and after each rainfall of 0.5 inch or greater.
- I. Bare soil areas must be seeded, mulched, or covered after 14 days if no work will be done in the area within the next 7 days. If areas are to be left bare for more than 14 days, erosion controls and sediment barriers are required to be installed.

- J. Erosion Control prevention measures shall be installed prior to removal of vegetation and/or stripping of topsoil.
- K. The Contractor shall obtain a Land Disturbance Permit from the Division of Engineering before commencing work.
- L. If the Contractor anticipates disturbing in excess of one acre, the Contractor shall be responsible for preparing and submitting to the Kentucky Division of Water the Notice of Intent and attachments and obtaining permit approval prior to the beginning of any construction activities.

4.2 MATERIALS

A. SEED

The temporary seed mixture, if required, to be sown shall be in accordance with Section 213.03.05 of the KDOH Standard Specifications.

B. MULCH

Mulch for seeded areas, if needed, shall be in accordance with Section 212.03.03 of the KDOH Standard Specifications.

C. TEMPORARY SILT FENCE

Temporary silt fence shall be in accordance with Section 213.03.05 of the KDOH Standard Specifications.

D. INLET PROTECTION DEVICES

Inlet protection devices shall be Dandy Curb Grateless Curb Inlet Protection System or equal.

4.3 GENERAL

- A. Erosion and sediment control practices shall be consistent with the requirements of the state and local regulatory agencies and in any case shall be adequate to prevent erosion of disturbed and/or regraded areas. Install and maintain in accordance with Sections 212 and 213 of the KDOH Standard Specifications.
- B. Contractor is responsible for notifying the state regulatory agency concerning inclusion under the KPDES General Permit for Storm Water Discharges From Construction Activities if disturbed area equals or exceeds one acre.

4.4 TEMPORARY STABILIZATION REQUIREMENTS

- A. Temporary Stabilization is required for all disturbed areas where active work is not being performed. Rough graded areas and topsoil piles that are not in active use must be seeded immediately. The Contractor shall follow the guidelines in the table below:

Temporary Stabilization Table

Area requiring temporary stabilization	Time frame to apply erosion controls
Any disturbed areas within 25 feet of a stream	Within 24 hours of the most recent disturbance if the area will remain idle for more than 21 days
For all construction activities, any disturbed areas that will be dormant for more than 21 days but less than one year, and not within 25 feet of a stream	Within seven days of the most recent disturbance within the area
Disturbed areas that will be idle over winter	Prior to the onset of winter weather
All areas where activity has temporarily ceased	Within 14 days

4.5 SEEDING

- A. Prepare soil and apply seeding, if needed, in accordance with Sections 212 and 213 of the KDOH Standard Specifications.

4.6 INSTALLATION OF EROSION AND SEDIMENT CONTROL DEVICES

- A. All erosion and sediment control products and materials shall be installed per manufacturer's recommendations and in accordance with the Kentucky Erosion Prevention and Sediment Control Field Guide and Sections 212 and 213 of the KDOH Standard Specifications and applicable KDOH Standard Drawings.

4.7 MAINTENANCE OF EROSION AND SEDIMENT CONTROL DEVICES

- A. Erosion and sedimentation controls shall be inspected weekly and after rain events of 0.5 inch or greater. Replace silt fencing as needed, filter stone which is dislodged, erosion control blanket which is damaged, and make other necessary repairs.
- B. Remove sediment from fences and barriers when it accumulates to half the height of the barrier, or more often as needed.

4.8 CLEAN UP

Upon completion of the project and/or establishment of satisfactory turf, vegetation or permanent erosion control structures, Contractor shall remove all temporary devices and properly dispose of such.

4.10 BASIS OF PAYMENT

Payment will be made at the Contract Lump Sum Price for Erosion Control and shall be full compensation for all labor, equipment, materials and incidentals to provide erosion and sedimentation controls for the site as needed. Payment for Sodding is a separate pay item.

TECHNICAL SPECIFICATIONS

SECTION 5 - SAWCUTTING CURB & GUTTER AND ASPHALT PAVEMENT

5.1 SCOPE

When sawcutting of curb and gutter, and asphalt pavement as called for in these Specifications or shown on the Drawings it shall require the use of an approved saw in order to obtain a smooth, straight line. Any existing facility, which is not marked for removal by the ENGINEER, but is nevertheless removed, shall be replaced at the CONTRACTOR'S expense.

5.2 BASIS OF PAYMENT

Payment for the accepted quantity will be made at the unit bid price per linear foot, which payment shall be full compensation for all Work required by this section.

TECHNICAL SPECIFICATIONS

SECTION 6 - REMOVE ASPHALT PAVEMENT, CONCRETE CURB & GUTTER, PIPE, MANHOLES, AND INLET STRUCTURES

6.1 SCOPE

Work will consist of the removal of asphalt pavement, concrete curb and gutter, pipe, manholes, inlet structures and granular bases. Work for this Section shall conform to the Kentucky Department of Highways Standard Specifications, Section 203, current edition and shall include all labor, materials, equipment, excavation, disposal, saw-cutting, and incidentals necessary to complete the Work. All materials shall be disposed of legally offsite at a location approved by the owner and in an acceptable manner

6.2 BASIS OF PAYMENT FOR REMOVAL OF ASPHALT PAVEMENT

Accepted quantities for Removal of Asphalt Pavement will be paid for at the Contract Unit Price per square yard as quoted (which shall be full compensation for all Work under this Section) and paid per square yard satisfactorily removed. All labor, materials, excavation, and equipment shall be incidental to the removal of Asphalt Pavement, including any granular bases.

6.3 BASIS OF PAYMENT FOR REMOVAL OF CONCRETE CURB AND GUTTER

Accepted quantities for Removal of Concrete Curb and Gutter will be paid for at the Contract Unit Price per linear foot as quoted (which shall be full compensation for all Work under this Section) and paid per linear foot satisfactorily removed. All labor, materials, excavation, and equipment shall be incidental to the removal of Concrete Curb and Gutter, including any granular bases.

6.4 BASIS OF PAYMENT FOR REMOVAL OF PIPE

Accepted quantities for Removal of Pipe will be paid for at the Contract Unit Price per linear foot as quoted (which shall be full compensation for all Work under this Section) and paid per linear foot satisfactorily removed. All labor, materials, excavation, and equipment shall be incidental to the removal of Pipe.

6.5 BASIS OF PAYMENT FOR REMOVAL OF MANHOLES AND INLET STRUCTURES

Accepted quantities for Removal of Manholes and Inlet Structures will be paid for at the Contract Unit Price per each as quoted (which shall be full compensation for all Work under this Section) and paid per each satisfactorily removed. All labor, materials, excavation, and equipment shall be incidental to the removal of Manholes and Inlet Structures.

TECHNICAL SPECIFICATIONS

SECTION 7 – REMOVE AND RECONSTRUCT SIDEWALK AND RAMPS

7.1 SCOPE

This Work consists of the demolitions and disposal of existing concrete sidewalk and ramps and the construction of new concrete sidewalk and new ADA-compliant sidewalk ramps on a thoroughly compacted subgrade in accordance with the Plans, Contract Documents and Specifications, and Lexington-Fayette Urban County Government (LFUCG) Standard Drawings numbers 304-306 current edition. Work in this section shall also conform to Sections 206, 207, 601, 801, 802, 803, 804, 805, and 823 of the Kentucky Department of Highways (KDOH) Standard Specifications, current edition, but only to the extent that these KDOH sections do not conflict with the content of the Plans, Contract Documents and Specifications, and LFUCG Standard Drawings as edited.

Concrete sidewalk and ramp shall be removed as indicated and disposed of legally off site.

Expansion joint material shall be of approved quality and of one-half (½) inch thickness. Expansion joints shall extend entirely and continuously through the concrete, and all excess expansion joint material shall be trimmed to conform to the surface of the concrete.

Concrete shall be sufficiently vibrated to assure removal of air voids. Concrete shall be struck off by use of a screed, floated and brushed. Edges and division marks shall be finished in a neat and workmanlike manner through use of the proper concrete finishing tools. Division joints in sidewalks shall be three-fourths (¾) inch in depth, and at intervals equivalent to the sidewalk width.

When it is necessary to replace portions of existing concrete sidewalks and entrance pavements, such existing features will be removed to the nearest transverse joint or division mark beyond the matching point indicated on the Plans. The existing concrete shall be sawed by an approved concrete saw. In the absence of a transverse joint or division mark, the sawing shall be performed as directed by the ENGINEER. It will not be permissible to place new concrete against the ragged edges of concrete caused by removal devices such as hand tools and air hammers or caused by breaks.

All concrete used shall be Class A concrete on which Type 2 (white pigmented) curing compound is used. Any pouring of concrete must be immediately preceded by inspection and approval of ENGINEER.

Work for this section shall include all labor, materials, equipment, excavation, and incidentals necessary to complete the Work, with the exception of Detectable Surface Warning Tiles. All work must be ADA compliant.

7.2 BASIS OF PAYMENT

Accepted quantities for Remove and Construct Concrete Sidewalk and Remove and Construct Sidewalk Ramps will be paid for at the respective Contract Unit Price as quoted (which shall be full compensation for all Work required under this Section) and paid per square yard satisfactorily removed and reconstructed. All labor, materials (except Detectable Warnings), equipment, and excavation shall be incidental to the placement of Sidewalk Ramps. Any required curb and gutter removal and replacement shall be incidental to the place of sidewalk ramps. Detectable Surface Warning Tiles shall be paid as a separate item.

TECHNICAL SPECIFICATIONS

SECTION 9 - EXCAVATION (UNCLASSIFIED)

9.1 SCOPE

The Work shall consist of the required removal and proper utilization or disposal of all excavated materials, embankments, and the shaping and finishing to the required lines and grades as shown on the Plans.

9.2 CLEARING AND GRUBBING

This item includes but is not limited to the removal, clearing and grubbing of any trees, stumps, brush, bushes, or other obstructions not specifically included in the Bid item. Also, included is the proper removal and legal disposal of such materials in a manner acceptable to the ENGINEER and in a manner not detrimental to the inhabitants of the area. The CONTRACTOR will be responsible for determining and complying with local ordinances regarding disposal and/or burning of such materials.

Work shall not be performed outside the right-of way limits and existing vegetation outside the limits shall not be disturbed unless authorized by the ENGINEER.

Also included in this item will be the careful removal and stockpiling for pickup by the OWNER of all streets and traffic signs, inlet grates, manhole frames and covers and other such salvageable and reusable items, not intended to be reset on the job.

Vegetated areas on which excavation or fill operations are to be performed shall be stripped of all vegetation, topsoil, and other organic material as directed by the ENGINEER.

When it is practical, stripped topsoil material may be utilized or disposed of in the general area it came from in a manner directed and approved by the ENGINEER.

To the extent that it does not conflict with the content of the Plans and Contract Documents and Specifications, Section 202 of KDOH Standard Specifications, current edition, is incorporated into this Technical Specification.

No separate payment will be included for Clearing and Grubbing but will be paid for as Excavation.

9.3 MATERIALS

All material removal shall be unclassified. This includes soil, rock and all other materials not classified as asphalt pavement, concrete curb and gutter, or concrete pavements. The Bidder must draw his own conclusions as to the conditions to be encountered.

9.4 GENERAL

Excavation and grading shall be done in a neat and workmanlike manner to form smooth and uniform subgrades and surfaces for all subsequent operations. Once the surfaces have been shaped to the proper template and compacted to the satisfaction of the Engineer and in accordance with the current edition of the Kentucky Department of Highways Standard Specifications, it shall be maintained in such condition until covered by subsequent construction operations.

Material removal shall include excavation to the designated depths, transporting of removed materials from points of removal to points of final use, disposal of surplus materials, and the shaping and finishing of all areas to the required lines and grades as shown on the Drawings.

Surplus material will become the responsibility of the Contractor to legally dispose of off the project limits at a site acquired by the Contractor at no expense to the Owner and approved by the Engineer.

9.5 PREPARATION OF SUBGRADE

Preparation of subgrade for pavements, bases, curbs, gutters, sidewalks, and medians shall conform to the required grades and the specified depth below the designated surface of the particular item for which it is intended.

At the direction of the Engineer, all soft and spongy places in the subgrade shall be excavated and backfilled with No. 2 coarse aggregate below the base course level, then brought to grade with Dense Graded Aggregate. Stone bridging materials shall be a separate pay item.

Once the subgrade has been shaped to the proper template and compacted to the satisfaction of the Engineer and in accordance with the Kentucky Department of Highways Standard Specifications for Road and Bridge Construction, current edition, it shall be maintained in such condition until covered by subsequent construction operations. Any portion of the subgrade, which cannot be shaped and compacted by the use of machinery, shall be prepared by the use of hand tools.

9.6 CONSTRUCTION METHODS

All suitable material removed shall be used, insofar as it is practicable, in constructing the fill and embankments shown on the Drawings provided that the Engineer approves.

9.7 CONSTRUCTION TOLERANCES

The Contractor shall make every reasonable effort to construct the project according to the plans.

No payment will be made for any earthwork performed outside the limits shown on the Drawings or those approved by the Engineer. No extra material shall be removed or placed outside of these limits without permission.

9.8 STANDARD SPECIFICATIONS

To the extent that they do not conflict with the content of the Plans and Contract Documents and Specifications, Sections 204 and 207 of KDOH Standard Specifications, current edition, are incorporated into this Technical Specification.

9.9 BASIS OF PAYMENT

Payment shall be made at the Contract Lump Sum Price for Excavation to include clearing and grubbing.

Excavation will not be measured but will be paid for at the Contract Lump Sum Price and shall be full compensation for all labor, equipment, and incidentals necessary to complete the Work, in place, ready for use.

TECHNICAL SPECIFICATIONS

SECTION 10 - NO. 2 STONE

10.1 SCOPE

The Work for this Section shall consist of furnishing and placing No. 2 Stone in locations as determined by the Engineer and shall include all labor, materials, equipment, excavation, and incidentals necessary to complete the Work in place, ready for use and constructed in conformance with KDOH Standard Specifications. No. 2 Stone meeting the requirements of KDOH Section 805 can be used for stabilizing subgrade and pavement subbase, etc.

No. 2 Stone shall be used as a subbase for DGA in the pavement template as shown on the typical section.

Also, where soft, undesirable soil material is encountered at or below desired subgrade elevation, undesirable material will be removed and/or bridged to develop a sufficient platform to support compaction of DGA. The depth and extent of this work shall be determined based on conditions observed and performance of compaction equipment on the subgrade. Work shall be directed by the Engineer.

Stone will be dumped or pushed into place and walked in until support is developed for heavy equipment. The ultimate test will be the ability to provide an adequate compaction platform for the DGA base.

10.2 BASIS OF PAYMENT

Payment for this Section will be at the Contact Unit Price per ton as quoted and shall be full compensation for all Work required under this section. No direct measurement shall be made. Payment shall be based on weight tickets for stone delivered and accepted for the work. All labor, materials, equipment, proof testing, excavation and disposal of excavated material shall be incidental to the placement of No. 2 Stone. Payment for Geotechnical Fabric required will be a separate pay item.

TECHNICAL SPECIFICATIONS

SECTION 11 - GEOTEXTILE CONSTRUCTION

11.1 SCOPE

Work for this Section shall be in accordance to Kentucky Department of Highways Standard Specifications Sections 214 and 843 (Type III, Geotextile Fabric for Subgrade or Embankment Stabilization), current edition and shall include all labor, excavation, materials, equipment, and incidentals necessary to complete the work.

11.2 BASIS OF PAYMENT

Accepted quantities for Geotextile Construction will be paid for at the Contract Unit Price as quoted which shall be full compensation for all Work required under this Section and paid per square yard of geotextiles satisfactorily placed. All labor, materials (other than the geotextile fabric), equipment, and excavation shall be incidental to the placement of Type III Geotextiles Fabric.

TECHNICAL SPECIFICATIONS

SECTION 12 – DENSE GRADED AGGREGATE BASE

12.1 SCOPE

This Work consists of the construction of Dense Graded Aggregate (DGA) base in accordance with the Plans, Contract Documents and Specifications, and Lexington-Fayette Urban County Government (LFUCG) Standard Drawings, current edition. Work in this section shall also conform to Sections 207, 302 and 805 of the Kentucky Department of Highways (KDOH) Standard Specifications, current edition, but only to the extent that these KDOH sections do not conflict with the content of the Plans, Contract Documents and Specifications. The requirements of KDOH Standard Specifications, Section 302, apply with the following changes:

- (1) Control strips will not be required or utilized for compaction control.
- (2) Test sections and target density, as prescribed in paragraph 302.03.04, will not be established.
- (3) Density measurements will be made at locations designated by the Engineer or his/her representative.
- (4) Additional tests requested by the Contractor will be at the CONTRACTOR'S expense.
- (5) The average of dry density measurements in a lift shall be equal to or better than 144 pounds per cubic foot (pcf). No individual measurement shall be less than 140 pcf.
- (6) In the event the dry density measurements are not met, laydown operations will be stopped in the substandard area identified by the Engineer or his/her representative. The Contractor will either continue compaction effort or rework the designated section until the requirements for dry density are satisfied.

Work for this section shall include all labor, materials, equipment, excavation, and incidentals necessary to complete the Work.

12.2 BASIS OF PAYMENT

Accepted quantities thus measured will be paid for at the Contract Unit Price per ton for DGA as quoted and shall be full compensation for all Work required under this Section. No direct measurement shall be made. Payment shall be based on weight tickets for stone delivered and accepted for the work. All labor, materials, equipment, and excavation shall be incidental to the placement of Dense Graded Aggregate.

TECHNICAL SPECIFICATIONS

SECTION 13 – STANDARD CURB AND GUTTER TYPE 1 or 2

13.1 SCOPE

This Work consists of the construction of Curb and Gutter Type 1 or 2 on a thoroughly prepared subgrade in accordance with the Plans, Contract Documents and Specifications, and Lexington-Fayette Urban County Government Standard Drawing, #301, current edition. Work in this section shall also conform to Sections 207, 506, 601, 801, 802, 803, 804, and 805 of the Kentucky Department of Highways (KDOH) Standard Specifications, current edition, but only to the extent that these KDOH sections do not conflict with the content of the Plans, Contract Documents and Specifications, and Lexington-Fayette Urban County Government Standard Drawings.

Any placement of concrete must be immediately preceded by inspection and approval of the Engineer.

Work for this section shall include all labor, materials, equipment, excavation, and incidentals necessary to complete the Work.

13.2 BASIS OF PAYMENT

Accepted quantities thus measured will be paid for at the Contract Unit Price per linear foot as quoted and shall be full compensation for all Work required under this Section. All labor, materials, equipment, and excavation shall be incidental to the placement of Standard Curb and Gutter, LFUCG Type 1 or 2.

TECHNICAL SPECIFICATIONS

SECTION 14 – CLASS A CONCRETE (SPECIAL PAVEMENT SECTIONS)

14.1 SCOPE

Unformed Class A concrete for special pavement section shall conform to the Kentucky Department of Highways Standard Specifications for Road and Bridge Construction, Section 601, Current Edition, and shall include all labor, materials, equipment and incidentals necessary to complete the Work.

14.2 BASIS OF PAYMENT

Payment for Class A Concrete for special pavement sections will be paid for the Contract Unit Price per cubic yard.

TECHNICAL SPECIFICATIONS

SECTION 15 - EDGE KEY

15.1 SCOPE

This Work shall consist of the construction of edge keys in accordance with the Plans, Contract Documents and Specifications, and Lexington-Fayette Urban County Government (LFUCG) Standard Drawing 318, current edition. Work in this section shall also conform to the Kentucky Department of Highways (KDOH) Standard Specifications, current edition, but only to the extent that this KDOH section does not conflict with the content of the Plans, Contract Documents and Specifications, and LFUCG Standard Drawings.

In performing this Work, the CONTRACTOR shall furnish a neat edge along the pavement, obtained by using an approved saw to cut a smooth and straight line (approximately two (2) inches deep) in the existing pavement surface prior to breaking away the adjacent pavement. Any existing facility which is not marked for removal by the ENGINEER, but is nevertheless removed, shall be replaced at the CONTRACTOR'S expense.

15.2 BASIS OF PAYMENT

Payment for the accepted quantity will be made at the Contract Unit Price per linear foot, which payment shall be full compensation for all Work required by this section.

TECHNICAL SPECIFICATIONS

SECTION 16 - ASPHALT CONCRETE BASE & SURFACE

16.1 SCOPE

This Work consists of the construction of a asphalt concrete base and surface in accordance with the Plans, Contract Documents and Specifications, and Lexington-Fayette Urban County Government (LFUCG) Standard Drawings, current edition. Work in this section shall also conform to Sections 109, 207, 401, 402, 403, 406, 407, 408, 804, 805, 806, and 807, of the KDOH Standard Specifications, current edition, but only to the extent that these KDOH sections do not conflict with the content of these Plans, Contract Documents and Specifications, and LFUCG Standard Drawings.

The new asphalt base shall be KDOH Class 3 1.00D PG76-22. The new asphalt surface shall be KDOH Class 3 0.38B PG76-22. All areas to be paved shall be cleaned before paving operations commence. Any small areas to be repaired and paved shall be sawcut a minimum of two (2") inches deep before placement of the new adjacent asphalt pavement.

An asphalt tack coat shall be applied to all old or trafficked pavement, sawcut edges, any concrete base course, and to other asphalt or concrete pavements or surfaces, horizontal or vertical, where any new asphalt pavement material will be placed. A joint sealant, Flexmaster Pourable Crack Sealant 1109 or approved equal will be used at all joints between any new pavement and any existing pavements.

16.2 BASIS OF PAYMENT

Accepted quantities of Class 3 Asphalt Base 1.00D PG76-22 and Class 3 Asphalt Surface 0.38B PG76-22 will be paid for at the Contract Unit Price per Ton as quoted in the Bid Schedule and shall be full compensation for all Work required under this section. Payment will be based on weight tickets delivered and accepted for the Work. Any water used to ensure that the pavement surface is draining is incidental to this pay item. All labor, materials, equipment, excavation, asphalt tack material, joint sealant, placement and compaction of the asphalt mix, incidentals and any other items necessary to complete the Work of this Section shall be incidental to the placement of the Class 3 Asphalt Base 1.00D PG76-22 and Class 3 Asphalt Surface 0.38B PG76-22.

Application of tack coat will be applied to old material surfaces, curb contact, cold base surfaces and as otherwise directed by the Engineer. Tack coat and joint sealant shall be incidental to this Contract and no direct payment shall be made.

TECHNICAL SPECIFICATIONS

SECTION 17 – ASPHALT PAVEMENT MILLING AND TEXTURING

17.1 SCOPE

Work for this Section shall conform to the Kentucky Department of Highways Standard Specifications, Section 408, current edition and shall include all labor, materials, equipment, incidentals necessary to complete Work, including disposal of all resultant cuttings.

17.2 BASIS OF PAYMENT

Accepted quantities for Asphalt Pavement Milling and Texturing will be paid for at the Contract Unit Price (which shall be full compensation for all Work required under this Section) and paid per ton of Asphalt Pavement Milling and Texturing satisfactorily completed. All labor, materials, and equipment shall be incidental to the Milling and Texturing of Bituminous Pavement.

TECHNICAL SPECIFICATIONS

SECTION 18 - SODDING

18.1 SCOPE

This work consists of the application of sod to disturbed surfaces in accordance with the Plans and Contract Documents and Specifications. Work in this section shall also conform to Sections 212 and 827 of the Kentucky Department of Highways (KDOH) Standard Specifications, current edition, but only to the extent that these KDOH sections do not conflict with the content of the Plans and Contract Documents and Specifications.

At locations specified on the Drawings, place a minimum four inches of topsoil to prepare the sod bed, incorporate fertilizer and agricultural limestone as needed and place the sod flush with any adjacent seeded or turfed area, pavement, curb, or other structure. Incorporate 10-10-10 fertilizer and agricultural limestone into a three (3) inch deep sod bed at a rate of 28 lbs/1,000 sq.ft. and 150 lbs/sq.ft. respectively.

ENGINEER will make an inspection to determine the acceptability of the sod between 3 and 6 months after completion of the project. Ensure that at least 90% is alive with no area of dead sod larger than one square yard.

Use sod that is either well rooted Kentucky Bluegrass or Tall Fescue sod. However, obtain ENGINEER'S approval prior to using Tall Fescue sod in residential areas. Use sod that is completely free from noxious weeds and reasonably free from other objectionable grasses and weeds, stones or other foreign materials detrimental to the development and future maintenance of the sod. Obtain sod from sources that are covered with grass having a maximum height of 3 inches. Obtain approval of the selected source prior to cutting.

Work for this section shall include all labor, materials, equipment, excavation, topsoil and incidentals necessary to complete the Work.

18.2 BASIS OF PAYMENT

Accepted quantities for Sodding shall be paid for at the Contract Unit Price per square yard (which shall be full compensation for all Work required under this Section) and paid per square yard of Sodding satisfactorily placed. All labor, materials, equipment, and excavation shall be incidental to the placement of Sod.

TECHNICAL SPECIFICATIONS

SECTION 20 – LIGHT POLE BASE

20.1 SCOPE

Work for this Section shall include all labor, excavation, materials, equipment, and incidentals necessary to furnish and install light pole bases for the relocation of existing street lights.

The work shall include construction of the concrete foundation and required raceways as shown on the Drawings and furnishing and installation of the cast aluminum transformer base.

20.2 BASIS OF PAYMENT

Accepted quantities shall be paid for at the Contract Unit Price per each as quoted as in the Bid Schedule and shall be full compensation for all Work under this Section. All labor, materials, equipment, and excavation shall be incidental to the installation of light pole bases.

TECHNICAL SPECIFICATIONS

SECTION 21 - ELECTRICAL CONDUIT FOR LIGHTING

21.1 SCOPE

Work under this Section shall include all labor, excavation, materials, equipment, bedding and backfilling in accordance with Sections 716 and 834 of the KDOH Standard Specifications for installation of conduit for future street lighting cable. All products and installation shall meet the requirements of Kentucky Utilities (KU) and shall be coordinated with KU prior to construction.

21.2 MATERIALS

Electrical conduit shall be Schedule 40 PVC. Conduit elbows shall be Schedule 40 PVC with 24-inch radius. Provide conduit as manufactured by Carlon, Cantex or approved equivalent. Provide pull-wire through the conduit to facilitate pulling the electrical wire by KU.

Conduits shall be U.L. listed per UL Standard 651 and conform to NEMA Standard TC-2. Conduits shall be "sunlight resistant where exposed to sunlight radiation. Conduits shall be rated for use with 90°C conductors. The use of rigid metal conduits for street lights is not permitted in any case.

Street light pull boxes shall be traffic rated (ANSI Tier 15 or better) and dimensions 13" wide by 24" length by 18" deep with flared sides. The box shall be made of polymer concrete with no base (open bottom). Conduit entry shall be from below the box via knockouts (for up to 2 - 2.5" conduits on each end) located on each side of the box near the corners.

A heavy-duty gasketed cover shall be provided with special cover logo to read "Street Lighting". Cover shall be skid-resistant with at least 2 bolts to fasten the lid. Box is to include stainless steel inserts and fasteners with tamper-resistant "standard" Penta-head bolts for the attachment of the cover.

Box and lid cover to be standard gray. Box shall be UL listed and approved equivalent to Quazite P/N PG1324BB18 Box and PG1324HG0041P Lid.

21.3 SUBMITTALS

Provide product data.

21.4 CONSTRUCTION METHOD

Install underground in trenches as shown on the Drawings.

Conduits shall be installed per the required minimum burial depths below:

- On private property (except under a private road) – 18”
- Under a road or driveway on private property – 30”
- In LFUCG-owned right-of-way (except directly under a road) – 18”
- Where directly under an LFUCG-owned road – 30”
- In State-owned right-of-way (except directly under a road) – 30”
- Where directly under a State-owned road – 42”

Conduit runs shall be installed with KU-specified pull boxes where straight-run pulls are longer than 300 feet or as required by KU to eliminate excessive conduit bends. Only one intermediate bend is permitted between the end “pull-points”.

21.5 PAYMENT

Payment for the accepted quantity will be made at the unit bid price of Electrical Conduit per linear foot, which payment shall be full compensation for all Work required by the section and shall include any required pull boxes.

TECHNICAL SPECIFICATIONS

SECTION 22 - CONDUIT FOR FIBER-OPTIC CABLE

22.1 SCOPE

Work under this Section shall be the installation of conduit for the installation of fiber-optic cable by others. The work shall be performed in accordance with LFUCG Division of Traffic Engineering specifications and the following enforcement codes:

- 1) National Electric Code
- 2) National Safety Code
- 3) International Municipal Signal Association
- 4) Manual on Uniform Traffic Control Devices
- 5) Work Zone Traffic Control Codes

The Work shall include all labor, excavation, materials, equipment, bedding, backfilling, and connections.

22.2 MATERIALS

The following materials shall be used on the project:

- 1) All conduits shall be Schedule 80/SDR 11 per LFUCG Traffic Engineering specifications.
- 2) All conduits shall be 2" Inner-Duct, HDPE, Orange.
- 3) All PVC conduits shall have a threaded PVC bushing installed on the end.
- 3) All conduits entering into junction boxes and/or traffic signal equipment shall be non-metallic, except where conduit extends above ground surface level.
- 4) All rigid steel conduits installed shall be bonded to ground and have threaded bushings on the ends.
- 5) All conduits installed above grade shall be rigid steel (including preformed 90's that attach to underground conduit).
- 6) Traffic bearing junction box. Box and lid shall be Tier 22 – 17-inch x 30-inch PD Stackable, open bottom with mouse holes. Approved equivalent to Quazite PD 1730-BB26 Box and PG 1730-HH00 Lid. Provide 9" dry well of #57 stone under the box to prevent standing water.
- 7) Fiber-optic cable shall be provided and installed by LFUCG.

22.3 SUBMITTALS

Provide product data.

22.4 INSTALLATION

Coordinate with LFUCG Traffic Engineering for the disconnection and removal of all affected existing fiber-optic cable.

All conduit shall be installed in trenches as shown on the Drawings at a minimum depth of 18 inches.

Maximum length between junctions shall be 800 feet.

Coordinate with LFUCG Traffic Engineering for the installation and reconnection of existing fiber-optic cable in the new conduit.

21.5 PAYMENT

Accepted quantities shall be paid for at the Contract Unit Price per linear foot and shall be full compensation for all Work under this section.

All labor, materials, equipment, excavation, bedding, backfilling, and traffic bearing junction boxes shall be incidental to the installation of Conduit for Fiber-Optic Cable.

TECHNICAL SPECIFICATIONS

SECTION 23 - ADJUST VALVE OR MANHOLE TO GRADE

23.1 SCOPE

Work for this Section shall include all labor, excavation, materials, equipment, and incidentals necessary to adjust existing valve boxes, manholes, frames and lids as necessary to match the finished grade elevation of the roadway. This includes valves and manholes currently not visible due to pavement overlays.

All valve boxes and manholes, frames, and lids shall be reset that are more than one-quarter inch over or under grade.

23.2 BASIS OF PAYMENT

Accepted quantities shall be paid for at the Contract Unit Price per each as quoted as in the Bid Schedule and shall be full compensation for all Work under this Section. All labor, materials, equipment, and excavation shall be incidental to the adjustment of the valve or manhole to match finished grade elevation.

TECHNICAL SPECIFICATIONS

SECTION 24 - PAVEMENT MARKINGS

24.1 SCOPE

New pavement markings in the Work area shall generally be of the kind and in the locations indicated in this specification and on the schematic drawings in this Document. The Contractor shall collect sufficient supplemental survey information to locate and identify all existing traffic markings, cross walks, turn/lane direction arrows, stop bars, and other traffic markings in the Work area. The Contractor shall install thermoplastic markings as soon as Work is sufficiently complete to allow installation of permanent markings. Until the permanent installation is completed, the contractor shall maintain temporary markings consistent with needs and in accordance with the AASHTO Manual on Uniform Traffic Control Devices, current edition. For field dispensed lane markings and for preformed markings to the extent that there is no conflict with provisions herein, the work will conform to KDOH Sections 714, 836, 837 and 839.

24.2 MATERIALS AND WORKMANSHIP

All markings, with the exception of median nose markings, shall be of thermoplastic. Median nose markings shall be painted.

Lane direction arrows, crosswalk markings, and stop bars shall be of the preformed thermoplastic type, composed of hydrocarbon resin, pigments, binders, and glass beads, which have been factory produced as a finished product to meet the requirements of the *Manual on Uniform Traffic Control Devices*. The thermoplastic shall conform to AASHTO designation M249-79 (86) with the exception of the relevant differences due to material being supplied in a preformed condition. Turn arrows shall be FHWA Standard No. 330241 and straight arrows shall be No. 330240; combination turn/thru arrows shall be No. 330142. The arrows, crosswalk markings, and stop bars should equal or exceed the specifications defined by Flint Trading, Inc.

The following are general requirements for the various markings:

Graded Glass Beads - The material must contain a minimum of 30 percent grades glass beads by weight. The beads shall be clear and transparent with no more than 20 percent consisting of irregular or fused spheroids and silica. The index of refraction shall not be less than 1.50.

Pigment - All markings for this contract are white except edge and median nose markings. A sufficient amount of titanium dioxide must be used to ensure a color similar to Federal Highway White, Color No. 17886, as per Federal Standard 595. The yellow edge and median nose markings shall contain sufficient yellow pigment to ensure a color similar to Federal Highway Yellow, Color No. 13655.

Skid Resistance - The surface must provide a minimum skid resistance value of 50 BPN when tested by ASTM E303.

Thickness - Preformed material must be supplied at a minimum thickness of 120 mils.

Environmental Resistance - The material must be resistant to deterioration due to exposure to sunlight, water, oil, gasoline, salt, or adverse weather conditions.

Application to Asphalt - Preformed material shall be applied using a propane torch per recommendations of the manufacturer. The material must be able to be applied at air and road temperatures of 32 degrees F. without any preheating of the pavement. The pavement must be clean, dry, and free of debris at the time of application. The instructions with each package shall be followed to assure proper application. While the material is still hot and receptive, the surface shall be flooded with a surplus of glass beads.

Application to Portland Cement Concrete - Requirements are the same as for asphalt except that a primer/sealer must be used prior to application to assure proper adhesion. This step shall conform to pertinent manufacturer's recommendations.

Packaging - The material shall be packaged in plastic film and with cardboard stiffeners as necessary to prevent damage by handling and transporting.

24.3 BASIS OF PAYMENT

The Work shall include all labor, materials, and costs necessary or incidental to supplying and installing markings in a workmanlike manner. Payment will be at Contract Unit Price per linear foot or each. Payment for temporary markings shall be included in the payment for Maintenance and Control of Traffic. Collecting survey information and layout are included in payment for Staking.

TECHNICAL SPECIFICATIONS

SECTION 25 – INLAID PAVEMENT MARKERS

25.1 SCOPE

- A. Work for this Section shall include all labor, materials, equipment, and incidentals necessary to furnish and install Inlaid Pavement Parkers (IPM) in recessed grooves in accordance with Kentucky Department of Highways Supplemental Specifications and applicable Standard Specifications, current edition.

25.2 MATERIALS

- A. **Markers:** Provide KYTC approved reflective lenses (mono-directional white or bi-directional yellow-red) with depth control breakaway positioning tabs. Before furnishing the markers, provide to the Engineer the manufacturer's current recommendations for adhesives and installation procedures. Use one brand and design throughout the project. Use markers meeting the specifications in the table below.

SPECIFICATIONS FOR HOUSING AND REFLECTOR	
Material:	Polycarbonate Plastic
Weight:	Housing 2.00 oz.
	Reflector 2.00oz.
Housing Size:	5.00" x 3.00" x 0.70" high
Specific Intensity of Reflectivity at 0.2° Observation Angle	
White:	3.0 at 0°entrance angle
	1.2 at 20°entrance angle
Yellow	60% of white values
Red	25% of white values

- B. **Adhesives:** Use adhesives that conform to the manufacturer's recommendations.

25.3 CONSTRUCTION

- A. **Installation:** Install IPMs in recessed grooves cut into the final course of asphalt pavement according to the manufacturer's recommendations. Do not cut the grooves until the pavement has cured sufficiently to prevent tearing or raveling. Cut installation grooves using diamond blades on saws that accurately control groove dimensions. Remove all dirt, grease, oil, loose or unsound layers, and any other material from the marker area which would reduce the bond of the adhesive. Maintain pavement surfaces in a clean condition until placing markers.

Prepare the pavement surfaces, and install the markers in the recessed groove according to the detail in the drawings. Use an approved snowplowable epoxy adhesive. Ensure that the adhesive bed area is equal to the bottom area of the marker, and apply adhesive in sufficient quantity to force excess out around the entire perimeter of the marker. Use materials, equipment, and construction procedures that ensure proper adhesion of the markers to the pavement surface according to the manufacturer's recommendations. Remove all excess adhesive from in front of the reflective faces. If any adhesive or foreign matter cannot be removed from the reflective faces, or if any marker fails to properly adhere to the pavement surface, remove and replace the marker at no additional cost.

- B. **Location and Spacing:** Install the markers in the pattern for high reflectivity with two (2) IPMs per groove. Locate and space markers as shown in the current standard drawings or sepias (note: use Inlaid Pavement Markers wherever Type V Pavement Markers are called for). Do not install a marker on top of a pavement joint or crack. Offset the recessed groove a minimum of 2 inches from any longitudinal pavement joint or crack and at least one inch from the painted stripe, ensuring that the finished line of markers is straight with minimal lateral deviation. Give preference to maintaining the 2-inch offset between recessed groove and joint as opposed to keeping the line of markers straight.

Place inlaid markers as much in line with existing pavement striping as possible. Place markers installed along an edge line or channelizing line so that the near edge of the plastic housing is no more than one inch from the near edge of the line. Place markers installed along a lane line between and in line with the dashes. Do not place markers over the lines except where the lines deviate visibly from their correct alignment, and then only after obtaining the Engineer's prior approval of the location.

If conflicts between recessed groove placement in relation to pavement joint and striping cannot be resolved, obtain the Engineer's approval to eliminate the marker or revise the alignment.

- C. **Restoration:** Be responsible for all damage to public and/or private property resulting from the work. Restore all damaged features in like kind materials and design at no additional cost.

25.4 BASIS OF PAYMENT

- A. **Inlaid Pavement Markers:** Payment will be made for the completed and accepted quantity of completely installed Inlaid Pavement Markers at the Contract unit price, each. Payment shall be full compensation for all labor, equipment, materials, and incidentals to accomplish this work to the satisfaction of the Engineer. A system of one (1) groove and two (2) markers shall be paid as one Inlaid Pavement Marker. The bid item shall be used regardless of the color and type of lenses required.

TECHNICAL SPECIFICATIONS

SECTION 26 - REMOVE AND REPLACE FENCE

26.1 SCOPE

Should any item of work require removing existing fence of any type or if any existing fence is damaged during construction, the CONTRACTOR shall remove such designated fence and make satisfactory disposal of the materials. The CONTRACTOR shall replace the fence in accordance with the requirements of KDOH Section 722.

26.2 MATERIALS

Fence requiring removing and replacement shall be replaced in kind with similar materials and construction.

26.3 METHOD OF MEASUREMENT

Removing and replacing fence, including gates, will be measured in linear feet along the top of the fence and gates from outside to outside of end posts for each continuous run complete and accepted.

26.4 BASIS OF PAYMENT

The accepted quantities of fence, including gates, removed and replaced will be paid for at the contract unit price per linear foot. Payment will be full compensation for all materials, equipment, and labor necessary to complete the Work.

TECHNICAL SPECIFICATIONS

SECTION 27 – MANHOLE CONSTRUCTION

27.1 SCOPE

Work for this Section shall consist of manhole construction for manholes less than eight feet zero inches (8'0") deep. Manholes greater than eight feet zero inches (8'0") deep shall be paid for as eight feet zero inches (8'0") manholes plus the additional vertical depth at the Contract Unit Price quoted.

At the option of the CONTRACTOR, manholes shall be constructed of precast concrete manhole rings. Manholes shall be constructed to conform to Lexington-Fayette Urban County Government Standard Drawings 100-105 (storm) unless otherwise noted or directed by the ENGINEER. Bases for manholes shall be poured in place using Class "A" concrete and shall have a minimum thickness of eight inches (8"). Field poured bases (doghouse manholes) shall only be allowed with prior approval of LFUCG. If no special instructions are given on the plans and precast manholes are used, the 6" overhang in the base section shown on the drawings shall not be required.

22.2 MATERIALS

- A. **Precast Concrete Rings:** Precast concrete rings for manholes shall conform to ASTM Standard Specifications C-76, Class II, Wall B, with a minimum concrete strength of 4,000 psi, except that rings for manholes over twelve (12) feet deep shall be Class III. Rings shall be of the tongue and groove type. New or replacement manholes shall be sized such that a 6" ring is installed to permit future height adjustment in either direction. Brick leveling courses shall not be used under any circumstances.
- B. **Precast Concrete Cones:** Precast concrete cones shall be of the size and shape shown on the plans and shall conform to the ASTM Standard Specification C-76 for the reinforced concrete sewer pipe, Class II and as specified above for Precast Concrete Rings.
- C. **Sealant for Concrete Rings:** Conseal or its equal shall be used as sealant. If mortar is used, it shall be composed of one part Portland Cement and two parts sand, to which a small amount of hydrated lime putty, not to exceed ten (10) pounds per bag of cement, may be added.
- D. **Manhole Steps:** Manhole steps shall be asphalt coated cast iron or polypropylene plastic coated steel rod or of a type and size approved by the ENGINEER.
- E. **Manhole Frames and Covers:** The Standard Manhole casting shall consist of 7" cast iron frames and 22-3/4 inch diameter covers weighing not less than 320 pounds for frame

and cover, dimensioned as shown on the plans unless otherwise noted. When used the manhole adjustable frames shall be set at their lowest adjusted level. CONTRACTOR shall not use adjusters to match grade. Manhole covers must set neatly in the rings with contact edges machined for even bearings and tops set neatly in the rings with contact edges machined for even bearings and tops flush with ring edge. They shall have sufficient corrugations to prevent slipperiness and be marked in large letters, "STORM SEWER, LEXINGTON, KENTUCKY". The lids shall have two pick holes about 1-1/2 inches wide and 1/2-inch deep with 3/8-inch undercut all around. They shall be equivalent to those manufactured for the Lexington-Fayette Urban County Government by J.R. Hoe and Sons, Middlesboro, Kentucky, and shall be of cast iron conforming to ASTM A-48, Class 35, Gray Iron Castings. The contact surfaces of covers and corresponding rings in the rims shall be machined to provide full perimeter contact.

22.3 CONSTRUCTION METHODS

A. Width and Depth of Excavation of Structure:

- a. **Earth Excavation:** In excavating for concrete structures, the required width shall be such as to permit forms to be constructed in the proper manner and to permit proper backfilling on completion of the structures. Depth of excavation for base shall be as shown on the Standard Drawings and/or as directed by the ENGINEER to obtain sufficient bearing.
- b. **Rock Excavation:** Rock excavation for structures will be measured between the vertical planes passing eighteen (18) inches beyond the outside of the base and from the surfaces of the rock to the neat lines of the bottoms of the structures or the actual bottom on the rock ledge.

B. **Laying Concrete Rings:** Mortar joints shall not be more than 3/8 inch thick horizontally and not less than 3/8 inch wide vertically at the inside face of the manhole. Precast concrete manhole rings shall be set level and plumb. Joints between sections shall not be less than 3/8 inch thick and the entire joint space between sections shall be completely filled with mastic designed for this purpose or other material approved by ENGINEER. In sewer manholes, masonry shall be carefully and neatly constructed around the inlet and outlet pipes so that there will be no leakage around the outer surface. The ENGINEER shall approve materials and techniques used to insure water and/or vacuum tightness.

C. **Manhole Inverts:** Manhole inverts shall be formed from Class "A" concrete as shown on the plans. Curved inverts shall be constructed of concrete and shall form a smooth, even, half-pipe section. The inverts shall be constructed when the manhole is being built using prefabricated forms. Changes in direction of flow through the invert shall be made to a true curve with as large a radius as the size of manhole or inlet will permit. Invert slabs which are situated at depths in excess of 12 feet shall be reinforced per Lexington-Fayette Urban County Government Standard Drawings.

- D. **Bases:** The excavation shall be kept free of water while the manhole is being constructed. After the foundation has been prepared and has been approved by the ENGINEER, the bottom shall be constructed to the required line and grade. After the bottom has been allowed to set for a period of not less than twenty four (24) hours, the manhole and inlet shall be constructed thereon.
- E. **Casting:** The cast iron steps shall be included in the wall of the manhole at the proper locations and elevations as the work progresses and shall be securely embedded (per Lexington-Fayette Urban County Government Standard Drawings). The cast iron frame for the manhole cover shall be set at the required elevation and properly anchored. Where manholes are constructed in paved areas, the top surface of the frame and cover shall be tilted to conform to the exact slope, crown and grade of the existing adjacent pavement. Frames shall be in full cement mortar beds or other approved material.
- F. **Backfilling:** Masonry Work shall be allowed to set for a period of not less than twenty four (24) hours. Outside voids shall be backfilled and compacted in the same manner as provided for backfilling of pipeline trenches. All loose or waste material shall be removed from the interior of the manhole or inlet. The manhole cover or inlet grating then shall be placed and the surface in the vicinity of the Work cleaned off and left in a neat and orderly condition. No back-filling shall be performed until the manhole has been inspected and approved for backfilling by the ENGINEER.

22.4 BASIS OF PAYMENT FOR STORM SEWER MANHOLES

Accepted quantities for Lexington Storm Sewer Manholes will be paid at the Contract Unit Price as quoted for their respective sizes (which shall be full compensation for all Work required under this Section) and paid per specified Storm Sewer Manhole satisfactorily placed. All labor, excavation, materials, and equipment for the manhole and its connections shall be incidental to the construction of manholes from zero (0) to eight (8) feet deep.

TECHNICAL SPECIFICATIONS
SECTION 28 – CURB AND DROP BOX INLET

28.1 SCOPE

Work for this Section shall include all labor, excavation, materials, equipment, and incidentals to construct LFUCG Type "A", "B", "C", and "D" Curb Box Inlets, KDOH type "B" Curb Box Inlet, and/or Type "13" and "16" Drop Box Inlets as specified in the Purchase Order in accordance with the Lexington-Fayette Urban County Government Standard Drawings Numbers 122-125, KDOH Standard Drawings RDB 013-06 through RDB 019-03 (7 dwgs total) and RDB 030-03 through RDB 035-03 (6 dwgs total), RDB 280-05 through RDB 282-03 (3 dwgs total), and shall conform to Kentucky Department of Highway Standard Specifications, Section 601, 602 and 710.

28.2 BASIS OF PAYMENT

Accepted quantities for Curb Box and/or Drop Box Inlets will be paid for at the Contract Unit Price as quoted for each type (which shall be full compensation for all Work under this Section) and paid per specified Curb Box and/or Drop Box Inlet satisfactorily placed. All labor, materials, equipment, and excavation shall be incidental to the placement of Curb Box and/or Drop Box Inlets.

**TECHNICAL SPECIFICATIONS
SECTION 30 –STORM SEWER PIPE**

30.1 SCOPE FOR RCP (REINFORCED CONCRETE PIPE) STORM SEWER

Work under this Section shall include all labor, excavation, materials, equipment, bedding, backfilling and legal disposal of unneeded and unsatisfactory material at site obtained by CONTRACTOR in accordance to Lexington-Fayette Urban County Government Standard Drawings 100, 102, 103, 104 and 105, and all incidentals necessary to construct Storm Sewer to the sizes and type indicated from zero (0) to eight (8) feet deep. Where the Standard Drawing requires a concrete cap, it shall be constructed according to KDOH Section 501 for consolidated, unfinished concrete. All RCP is Class III unless noted otherwise.

- A. **LAYING** Pipe shall be laid to the line and grade shown on the drawings. Pipe shall be laid with the bell or groove at the upstream end of each section.

- B. **JOINING PIPE** The joint design for concrete pipe shall be bell and spigot or tongue and groove. The bell or tongue shall be of confined gasket or single offset spigot configuration to properly contain and seat the rubber gasket. The joint assemblies shall be accurately formed so that when each pipe section is forced together in the trench the assembled pipe shall form a continuous watertight conduit with smooth and uniform interior surface, and shall provide for slight movement of any piece of the pipeline due to expansion, contraction, settlement or lateral displacement. The gasket shall be the sole element of the joint providing water tightness. The ends of the pipe shall be in planes at right angles to the longitudinal centerline of the pipe, except where bevel-end pipe is required. The ends shall be furnished to regular smooth surfaces. Rubber gasket joints for tongue and groove or bell and spigot pipe using a confined gasket joint shall consist of an O-ring rubber gasket or other approved gasket configuration and shall conform to the requirements of ASTM 361, ASTM C443, ASTM C1619, or ASTM C1628 for the pipe designated. Rubber gasket joints for tongue and groove or bell and spigot pipe using a single offset joint shall consist of a non-circular rubber gasket or other approved gasket configuration and shall conform to the requirements of ASTM C76 or ASTM 361 for the pipe designated. Gaskets may be natural rubber, isoprene or neoprene conforming to ASTM C1619.

- C. **INSPECTION** All RCP pipe shall be inspected in accordance with Section 26 Internal Inspection of Sewer Pipe: CCTV as directed by the Engineer.

30.2 BASIS OF PAYMENT FOR RCP STORM SEWER

Accepted quantities for RCP Storm Sewer will be paid for at the Contract Unit Price as quoted for various sizes (which shall be full compensation for all work required under this Section) and paid per linear foot of specified RCP Storm Sewer satisfactorily placed. Any removal of pavement and sidewalk and any rock encountered between zero (0) and eight (8) feet shall be paid for under appropriate Bid Items in addition to the Unit Price

for RCP storm sewer. Concrete caps shall be paid under the Bid Item for unfinished concrete. Surface restoration (seeding, sod, pavement, etc.) will be paid separately under the appropriate Bid Items and the pay limits for surface restoration shall be in accordance with the appropriate Standard Drawings. Limits of surface restoration will be those limits as shown on the plans. All labor, materials, equipment, excavation, bedding, disposal and backfilling shall be incidental to the placement of RCP Storm Sewer.

PART IX

ADDENDA

Addendum
Number

Title

Date

1.

2.

3.

4.

5.

Appendix A
Standard Drawings

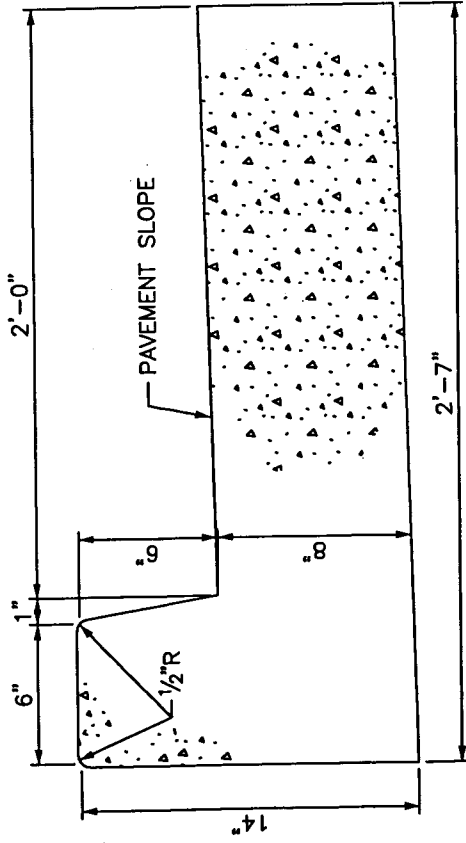

TYPE 2

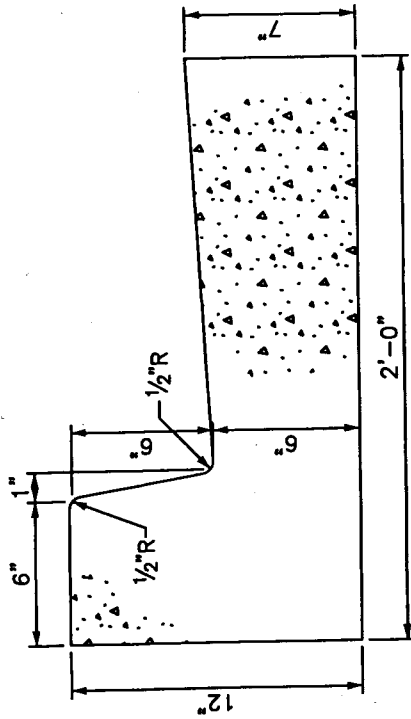

TYPE 1

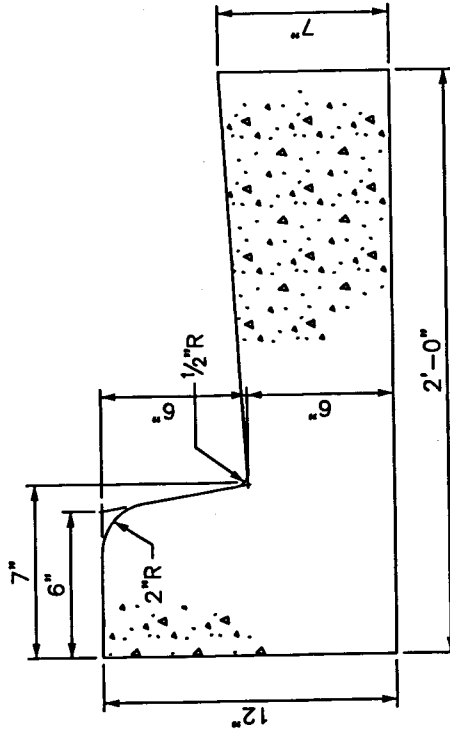

TYPE 3

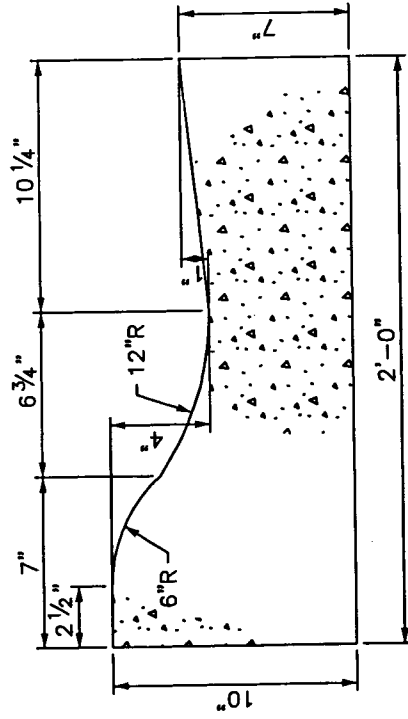

TYPE 4
(RESIDENTIAL LOCAL STREETS ONLY)

NOTES:

1. CONCRETE SHALL BE KDOT CLASS "A".
2. SAWED CONTRACTION JOINTS SHALL BE CONSTRUCTED EVERY 20 FEET, WITH A MIN. DEPTH OF 3", IN ACCORDANCE WITH KDOT STANDARD SPECIFICATION.
3. EXPANSION JOINTS SHALL BE CONSTRUCTED AT ALL BREAKS IN ALIGNMENT, AT CONTACT WITH NEW OR EXISTING CONCRETE, AT ALL DRAINAGE INLETS, AT THE BEGINNING AND ENDING POINTS OF CURVES, AND NOT TO EXCEED 200' MAXIMUM SPACING FOR SLIP FORM APPLICATION AND 30' MAXIMUM SPACING FOR HAND PLACED.
4. ALL CONCRETE SHALL BE CURED WITH WHITE PIGMENTED MEMBRANE FORMING COMPOUND (AASHTO M 148, TYPE 2).

NO.	DATE	REVISION DESCRIPTION	BY
DIVISION OF ENGINEERING			
CURB & GUTTER			
STANDARD DRAWING NO. 301		DATE 5/1/08	
APPROVED BY <i>[Signature]</i>		DATE 5/1/08	
DESIGNED BY <i>[Signature]</i>		DATE 5/1/08	
CHECKED BY <i>[Signature]</i>		DATE 5/1/08	
COMMISSIONER		DATE	

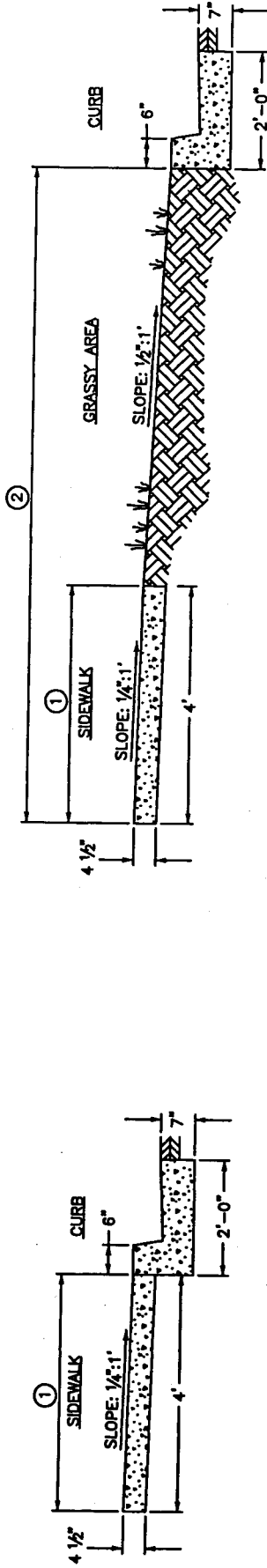

SIDEWALK/CURB AND GUTTER

SIDEWALK/CURB AND GUTTER WITH GRASS UTILITY STRIP

NOTES:

1. CONCRETE SIDEWALKS AND WALKWAYS SHALL BE CONSTRUCTED ON A THOROUGHLY COMPACTED SUB-GRADE AND SHALL BE FOUR AND ONE HALF (4 1/2) INCHES IN THICKNESS AND A MINIMUM WIDTH OF FOUR (4) FEET. CONCRETE SHALL HAVE SPECIFICATIONS FOR CLASS "A", KENTUCKY DEPARTMENT OF HIGHWAYS, STANDARD SPECIFICATIONS, CURRENT EDITION. WHITE PIGMENTED (TYPE 2, CLASS "A" OR "B") CURING COMPOUND IS REQUIRED (ALSO KENTUCKY DEPARTMENT OF HIGHWAYS, STANDARD SPECIFICATIONS, CURRENT EDITION).
2. EXPANSION JOINTS SHALL BE PLACED AT THIRTY-TWO (32) FOOT INTERVALS. IN EXISTING NEIGHBORHOODS, EXPANSION MATERIAL SHALL BE PLACED AT THE BEGINNING AND END OF NEWLY CONSTRUCTED AREAS.
3. THE SIDEWALKS SHALL BE PLACED ADJACENT TO THE STREET RIGHT-OF-WAY LINE. SLOPE TOWARD CURB SHALL BE ONE QUARTER (1/4) OF AN INCH TO THE FOOT. CONSTRUCTION IN EXISTING NEIGHBORHOODS SHALL REQUIRE THE CONTRACTOR TO MATCH EXISTING GRADE AND SIDEWALK WIDTH UNLESS SPECIFIED OTHERWISE BY THE DIVISION OF ENGINEERING.

SHEET NOTES:

- ① NORMAL SIDEWALK WIDTH SHALL BE 4' UNLESS CHANGE IS AUTHORIZED BY URBAN COUNTY ENGINEER'S OFFICE.
- ② DISTANCE WILL VARY WITH ROAD CROSS-SECTION.

NO.	DATE	REVISION DESCRIPTION	BY
DIVISION OF ENGINEERING			
SIDEWALK CONSTRUCTION SPECIFICATIONS			
STANDARD DRAWING NO.	303		
APPROVED			
DATE	5/1/08		
DESIGNED			
CHECKED			
COMMISSIONER			

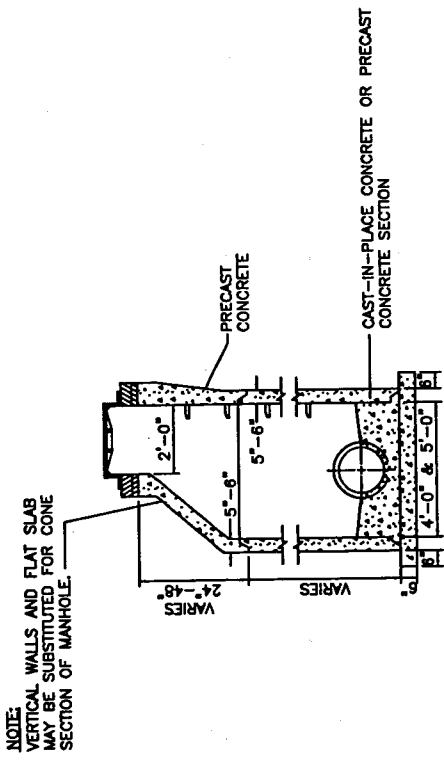
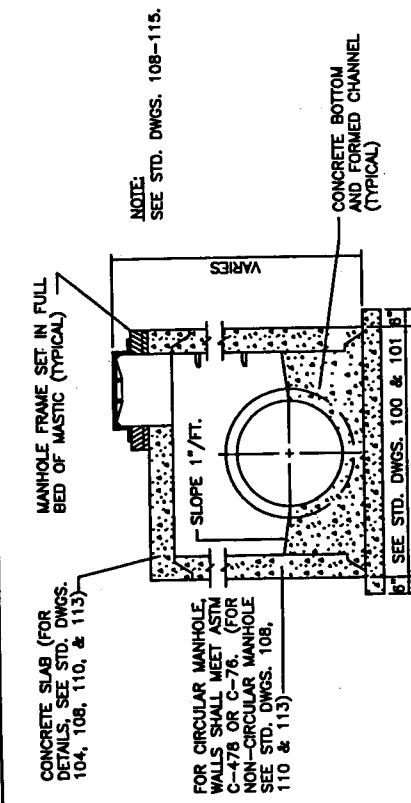

CIRCULAR AND NON-CIRCULAR WALLS
(TYPE "A" & TYPE "B")

STANDARD 4'-0" DIA. & 5'-0"
CIRCULAR WALLS
(TYPE "A")

- NOTES:
1. BASE SECTION OF CIRCULAR MANHOLES MAY BE CAST-IN-PLACE CONCRETE OR CUSTOM PRECAST CONCRETE WITH OPENINGS FOR PIPE.
 2. 6" OVERHANG IN BOTTOM SLAB IS NOT REQUIRED IF PRECAST MANHOLES ARE USED.
 3. FLAT SLABS IN PAVED AREAS SHALL BE USED ONLY AS APPROVED BY ENGINEER.

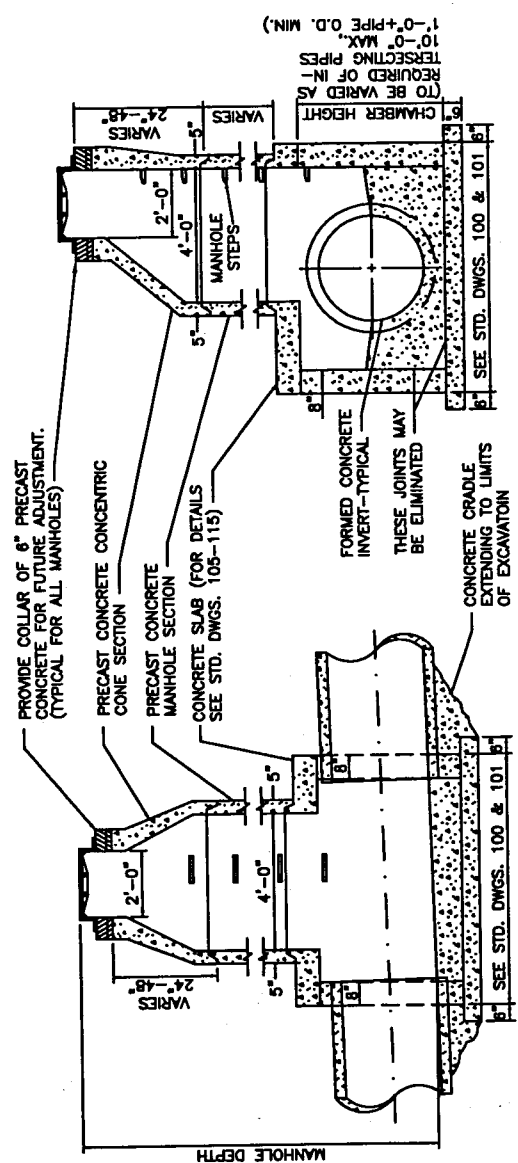

TYPICAL LONGITUDINAL SECTION

TYPICAL TRANSVERSE SECTION

STANDARD CIRCULAR MANHOLE - 6'-0" DIAMETER & LARGER TYPE "A"
AND NON-CIRCULAR WALL MANHOLE - ALL SIZES TYPE "B"

NO.	DATE	REVISION DESCRIPTION	BY
DIVISION OF ENGINEERING			
STORM SEWER MANHOLE DETAILS			
STANDARD DRAWING NO. 102			
APPROVED: <i>[Signature]</i> 5/1/68			
DRAWN BY: <i>[Signature]</i> 5/1/68			
CHECKED BY: <i>[Signature]</i> 5/1/68			
DATE			

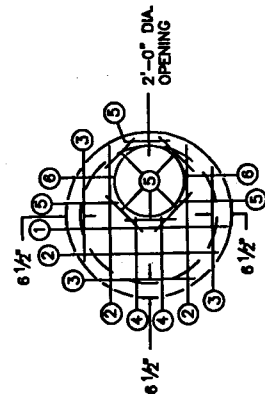

MARK NO.	SIZE	LENGTH	TYPE
1	4	4'-5"	STR.
2	3	4'-0"	"
3	3	2'-8"	"
4	2	2'-0"	"
5	8	1'-6"	"
6	2	1'-0"	"

4'-0" DIA.

SHALLOW MANHOLES

NOTES:

1. FOR PIPE SIZES 15" TO 24".
2. 9" O.C. SPACING EACH WAY.
3. 8" THICK SLAB.
4. 4'-10" O.D.
5. 2" MIN. STEEL REINFORCEMENT COVER ALL FACES.
6. CIRCULAR REBAR MAY BE USED, OR MARK 5 BARS AS SHOWN.

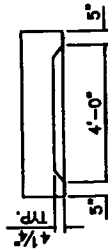

SIDE VIEW

NOTE:
SLAB OUTER DIAMETER TO VARY WITH MANHOLE WALL THICKNESS. TO COMPLETELY COVER MANHOLE WALLS.

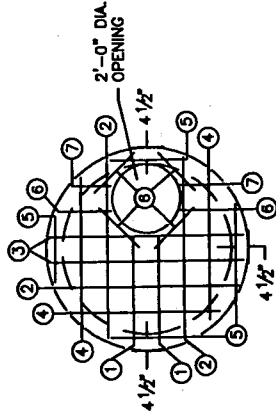

MARK NO.	SIZE	LENGTH	TYPE
1	2	3'-2"	STR.
2	3	5'-3"	"
3	2	5'-8"	"
4	3	4'-2"	"
5	4	2'-2"	"
6	6	1'-6"	"
7	2	1'-0"	"

5'-0" DIA.

SHALLOW MANHOLES

NOTES:

1. FOR PIPE SIZES 21" TO 33".
2. 9" O.C. SPACING EACH WAY.
3. 8" THICK SLAB.
4. 6'-0" O.D.
5. 2" MIN. STEEL REINFORCEMENT COVER ALL FACES.
6. CIRCULAR REBAR MAY BE USED, OR MARK 6 BARS AS SHOWN.

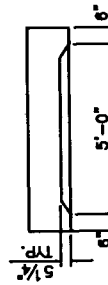

SIDE VIEW

NO.	DATE	REVISION DESCRIPTION	BY
DIVISION OF ENGINEERING			
STORM SEWER			
MANHOLE CIRCULAR SLABS			
4'-0" & 5'-0" DIAMETER			
STANDARD DRAWING NO.	104		
APPROVED	DATE	5/1/08	

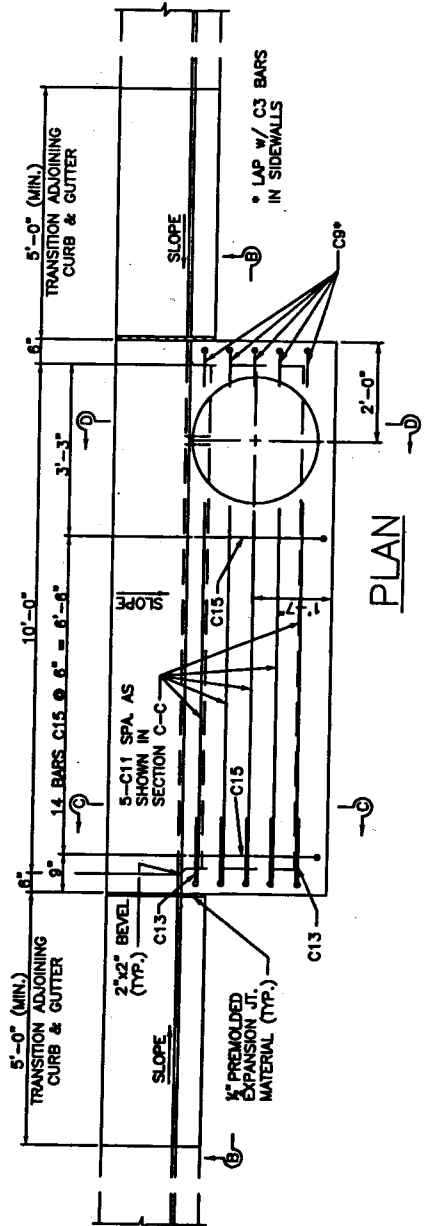

PLAN

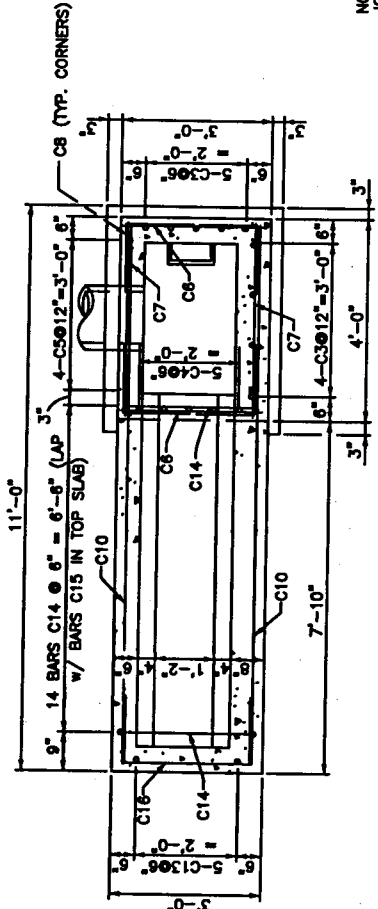

SECTION A-A

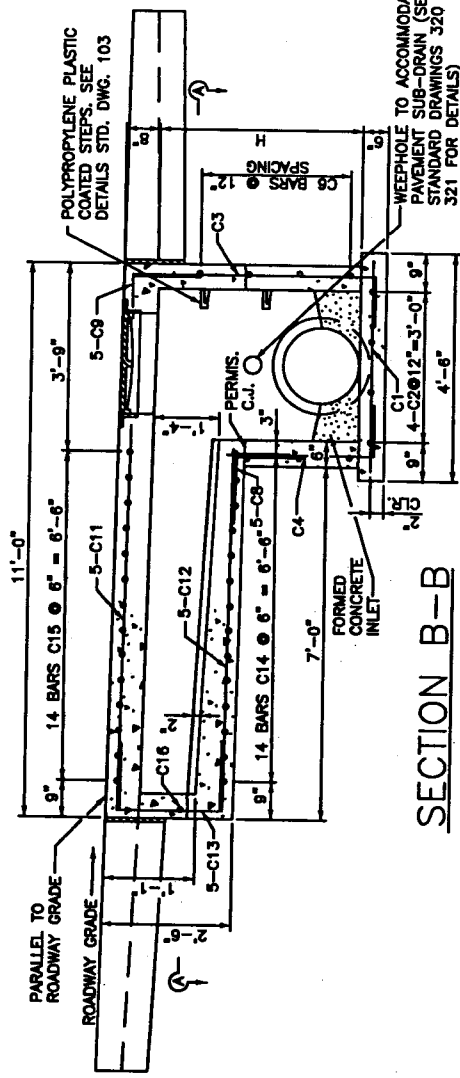

SECTION B-B

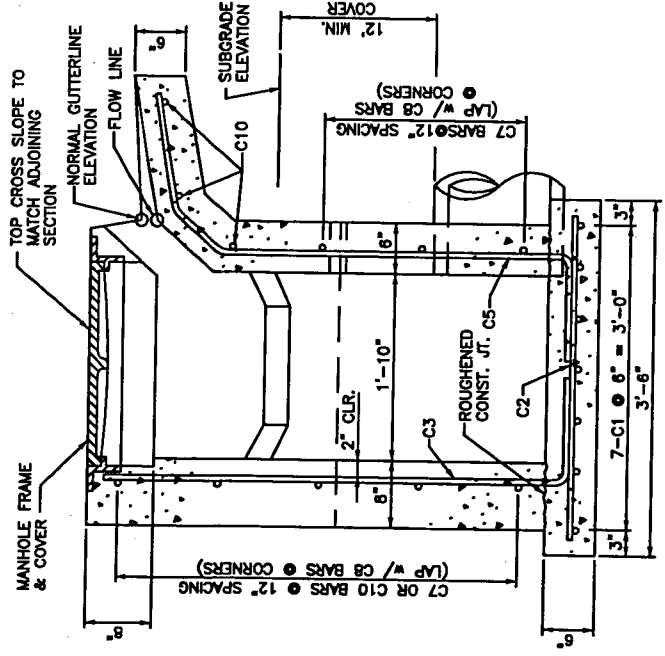

SECTION D-D

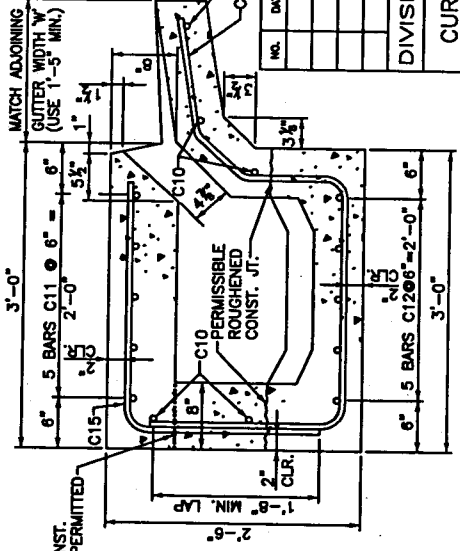

SECTION C-C

SEE STD. DWG. 124-2 FOR BILL OF REINFORCEMENT & ADDITIONAL DETAILS.

NO.	DATE	REVISION DESCRIPTION	BY

DIVISION OF ENGINEERING
 CURB BOX INLET TYPE "C"
 4'X3' BOX
 SINGLE PIPE
 15" OR LESS

STANDARD DRAWING NO. 124-1
 APPROVED: *[Signature]* 5/1/08
 DATE: 5/1/08
 COMMISSIONER: *[Signature]*

BILL OF REINFORCEMENT

MARK	TYPE	SIZE	NO.	LENGTH FT. IN.	LOCATION	DETAIL 'A'			
						a FT. IN.	b FT. IN.	c FT. IN.	d FT. IN.
C1	STR	#5	7	4	FOOTING				
C2	STR	#5	4	3	FOOTING				
C3	1	#5	9	H+(1'-10")	CHAMBER WALLS	1	0	H+10"	
C4	1	#5	5	H-4"	CHAMBER WALLS	1	0	H-(1'-4")	
C5	3	#5	4	H+(2'-4")	CHAMBER WALLS				
C6	STR	#5	7*	2	CHAMBER WALLS				
C7	STR	#5	6*	3	CHAMBER WALLS				
C8	1	#5	19*	2	CORNERS	1	4	1	4
C9	1	#5	5	2	CHAMBER WALLS & TOP	1	4	0	9
C10	STR	#5	5	10	THROAT & APRON				
C11	STR	#5	5	7	TOP SLAB				
C12	STR	#5	5	7	THROAT				
C13	2	#5	5	4	END THROAT	2	1	1	4
C14	4	#5	14	7	THROAT & APRON				
C15	1	#5	14	4	THROAT	1	11	2	6
C16	2	#5	1	5	END THROAT	2	6	1	4

* NO. OF BARS REQUIRED FOR H=4'-0"
ADD OR DEDUCT 2-C6, 2-C7 & 4-C8 FOR EACH 1'-0" INCREASE OR DECREASE IN H.

BAR TYPES

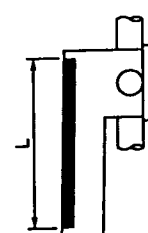
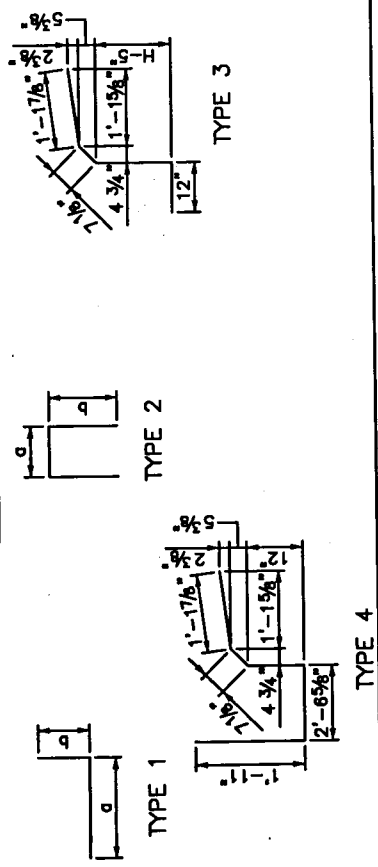

GRADE

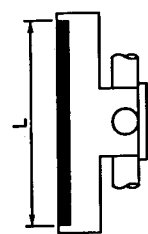

SAG

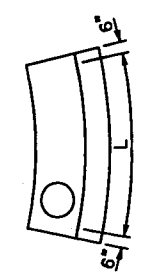

CURVE LENGTH

DETAIL 'A'
APPLICABLE SITUATIONS

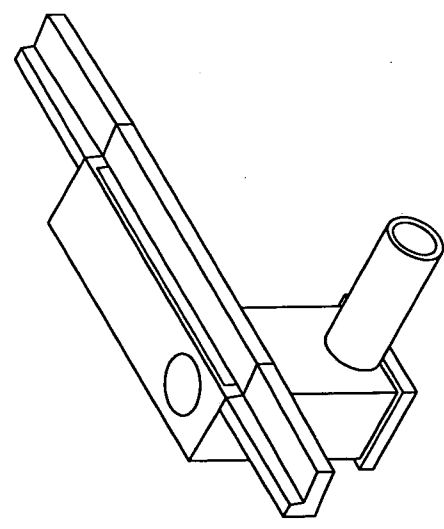

ISOMETRIC VIEW

WORK THIS DWG. WITH STD. DWG. 124-1

NO.	DATE	REVISION DESCRIPTION	BY

DIVISION OF ENGINEERING

CURB BOX INLET TYPE "C"
4'X3' BOX
SINGLE PIPE
15" OR LESS

STANDARD DRAWING NO. 124-2
APPROVED: *[Signature]* DATE: 5/1/02
DRAWN BY: *[Signature]* DATE: 5/1/02
COMMISSIONER

- NOTES:**
- CONCRETE SHALL HAVE A MINIMUM 28 DAY COMPRESSIVE STRENGTH OF 3500 PSI. STEEL REINFORCEMENT SHALL BE ASTM A-615, GRADE 60. ALL EXPOSED EDGES SHALL BE BEVELED 3/4" UNLESS OTHERWISE SHOWN.
 - THIS DRAWING DEPICTS A CURB BOX INLET IN A GRADE SITUATION. FOR CURB BOX INLET IN SAG SITUATION, DETAILS SHALL BE MODIFIED AS INDICATED IN DETAIL 'A'.
 - THE STANDARD OPENING LENGTH IS 10'-0" AS DETAILED HERE. THIS LENGTH MAY BE INCREASED OR DECREASED BASED ON HYDRAULIC ANALYSIS AND APPROVAL BY THE LEXINGTON-FAYETTE URBAN COUNTY GOVERNMENT ENGINEER. MODIFICATION TO THE OPENING LENGTH WILL REQUIRE MODIFICATION OF LENGTH OF BARS C10, C11 & C12 AND INCREASE OR DECREASE IN NUMBER OF BARS C14 & C15 MAINTAINING THE SAME MAXIMUM SPACING SHOWN ON THIS DRAWING.
 - MAXIMUM "H" FOR APPLICATION OF THIS DRAWING SHALL BE 5 FEET.
 - FIELD BEND OR CUT BARS C3, C5, C6 & C7 AS NECESSARY WHERE PIPES PENETRATE CHAMBER WALLS.
 - FOR CURB BOX INLET IN CURVE WITH CURB RADIUS OF LESS THAN 25', LONGITUDINAL BARS C10, C11 & C12 SHALL BE SHOP FABRICATED RADIALLY.

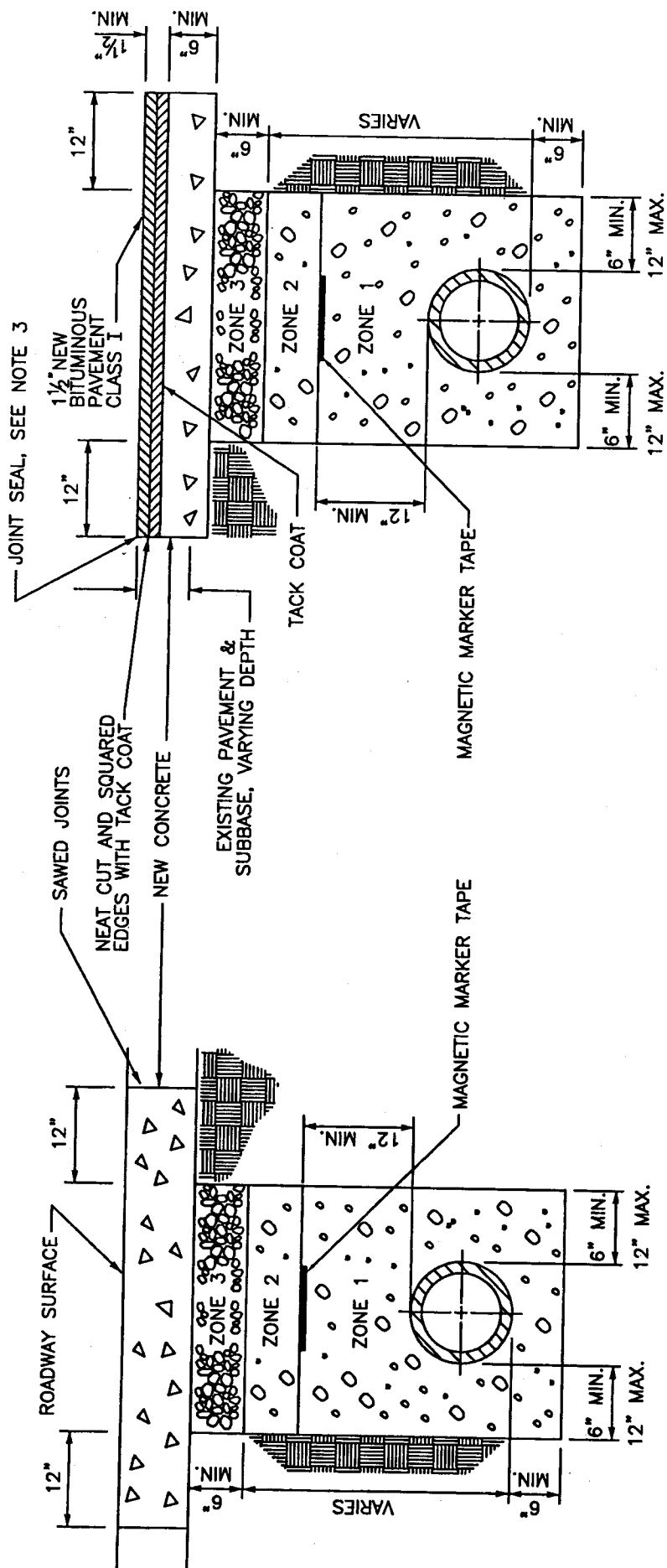

CONCRETE PAVEMENT

PIPE BACKFILL DESCRIPTIONS	
ZONE 1	NO. 9 STONE
ZONE 2	NO. 9 OR NO. 57 STONE
ZONE 3	COMPACTED DGA
ZONE 4	CONSOLIDATED SOIL, (NO ROCK GREATER THAN 6" DIAMETER), NO. 9, OR NO. 57 STONE
ZONE 5	12" MAX. TOPSOIL, NO ROCK ALLOWED

BITUMINOUS PAVEMENT

- NOTES:**
1. REPLACE CONCRETE PAVEMENT WITH NEW CONCRETE PAVEMENT 6" MINIMUM OR EXISTING THICKNESS, WHICHEVER IS GREATER.
 2. JOINT SEAL PERIMETER OF CUT PAVEMENT WITH FLEXMASTER POURABLE CRACK SEALANT 1109 OR APPROVED EQUAL.
 3. MAGNETIC MARKER TAPE FOR SANITARY SEWER ONLY.

NO.	DATE	REVISION DESCRIPTION	BY
DIVISION OF ENGINEERING			
TRENCHING, LAYING, BACKFILLING AND BEDDING UNDER STREET PAVEMENT			
STANDARD DRAWING NO.	201-1		
APPROVED	5/1/00		
DATE	5/1/00		
BY	[Signature]		
COMMISSIONER	[Signature]		

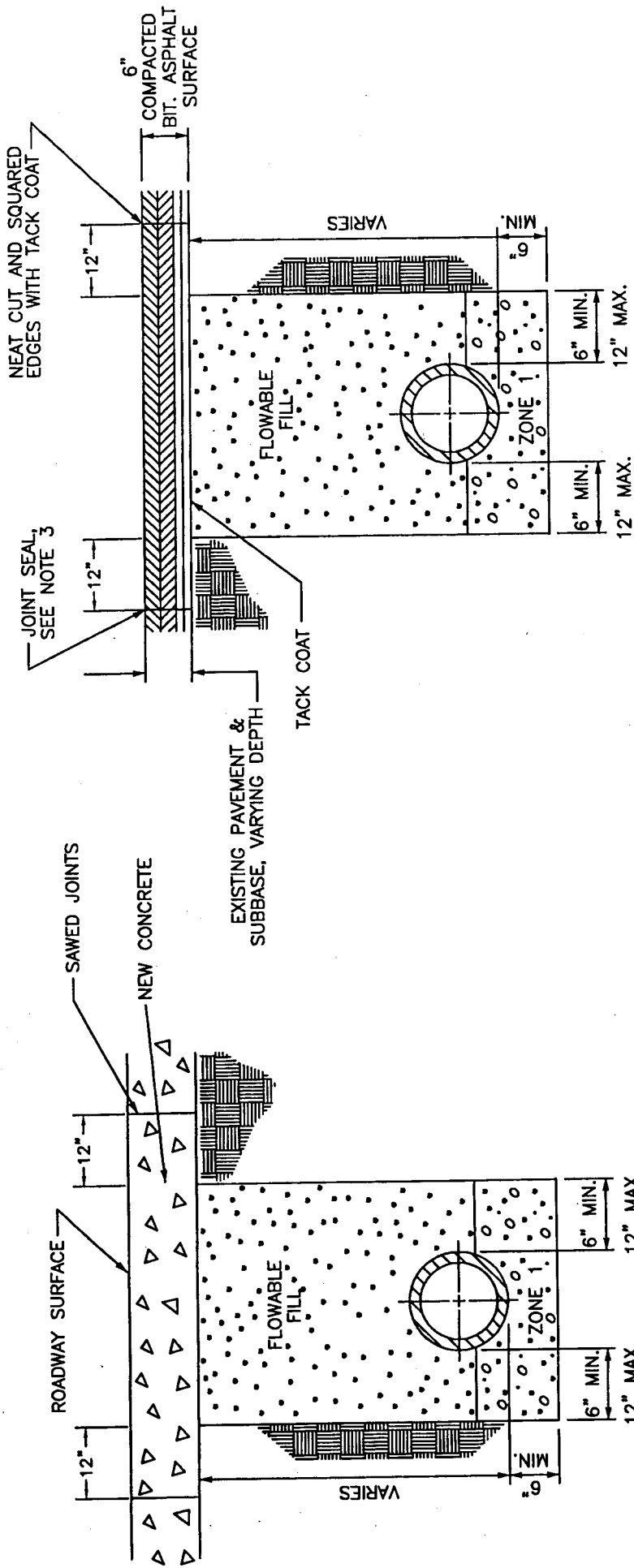

BITUMINOUS PAVEMENT

CONCRETE PAVEMENT

- NOTES:**
- PER KYTC SPECIFICATION 601.03.03 FROM STANDARD SPECIFICATIONS FOR ROAD AND BRIDGE CONSTRUCTION EDITION 2004, OR MOST RECENT.
 - REPLACE CONCRETE PAVEMENT WITH NEW CONCRETE PAVEMENT, 6" MINIMUM OR EXISTING THICKNESS, WHICHEVER IS GREATER.
 - JOINT SEAL PERIMETER OF CUT PAVEMENT WITH FLEXMASTER POURABLE CRACK SEALANT 1109 OR APPROVED EQUAL.

PIPE BACKFILL DESCRIPTIONS	
ZONE 1	NO. 9 STONE
ZONE 2	NO. 9 OR NO. 57 STONE
ZONE 3	COMPACTED DGA
ZONE 4	CONSOLIDATED SOIL (NO ROCK GREATER THAN 6" DIAMETER), NO. 9, OR NO. 57 STONE
ZONE 5	12" MAX. TOPSOIL, NO ROCK ALLOWED

NO.	DATE	REVISION DESCRIPTION	BY
DIVISION OF ENGINEERING			
TRENCHING, LAYING, BACKFILLING, AND BEDDING UNDER STREET PAVEMENT USING FLOWABLE FILL			
STANDARD DRAWING NO.	201-2		
APPROVED	5/1/08		
LEXINGTON COUNTY ENGINEER			
COMMISSIONER			

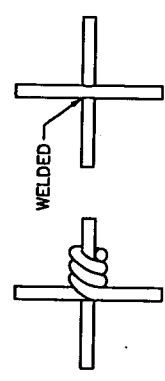
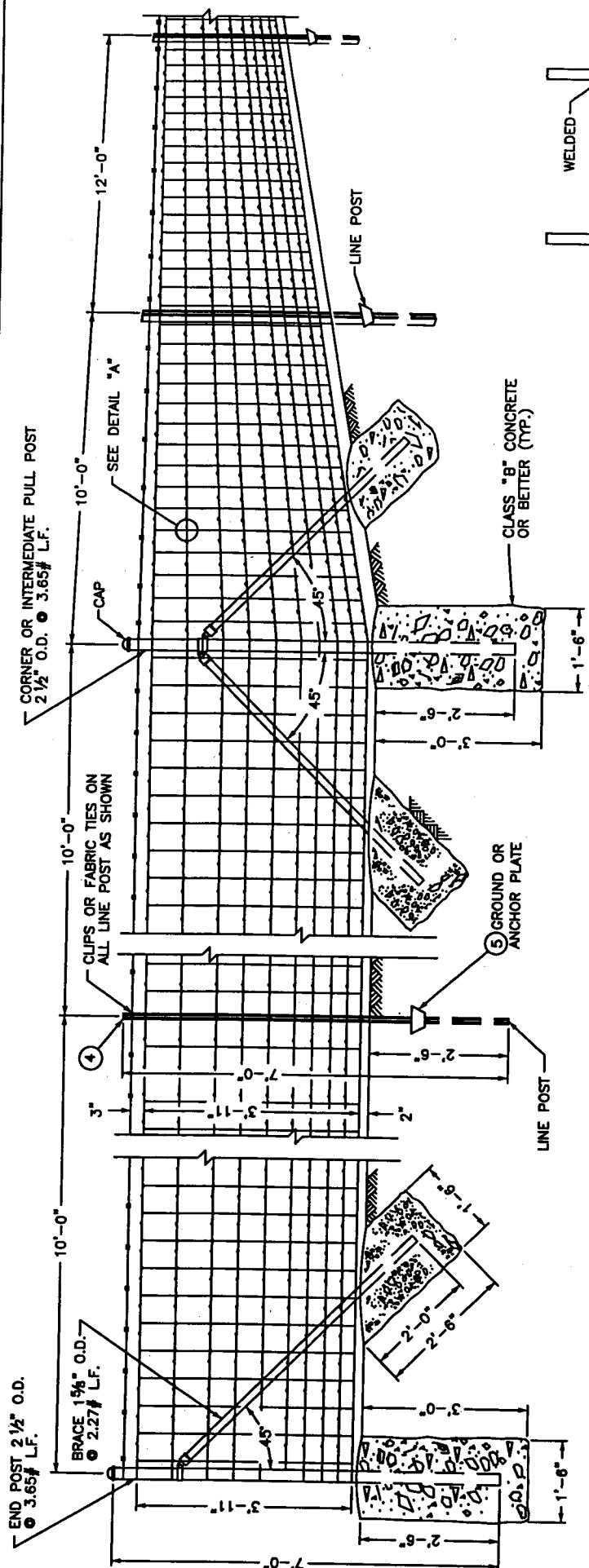

- NOTES:**
1. WOVEN-WIRE USED FABRIC IN RIGHT-OF-WAY FENCE SHALL BE EITHER ALUMINUM-COATED STEEL NO. 1047-6-9 OR ZINC-COATED STEEL NO. 1047-6-9.
 2. ALL FENCE FITTINGS SHALL COMPLY WITH ASTM F 626.
 3. O.D. DEPICTED FOR TUBULAR POSTS IS NOMINAL - ASTM F 1083 SHALL GOVERN.
 4. STUDDED "T" POST AT 1.33 LBS. PER FOOT.
 5. GROUND OR ANCHOR PLATE
- ROLL FORM POST AT 1.35 LBS. PER FOOT. (SEE DETAIL)
 NOT REQUIRED FOR ROLL FORM POST.

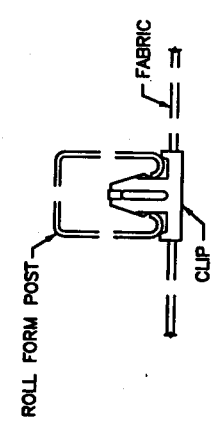
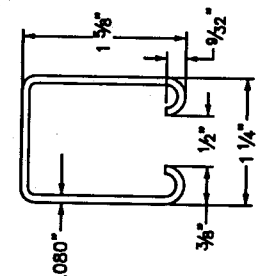
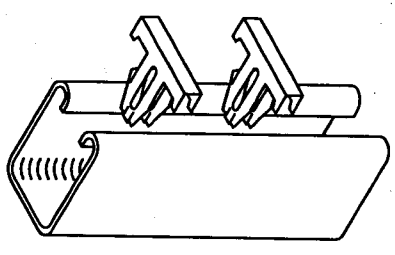

REV.	DATE	REVISION DESCRIPTION	BY
DIVISION OF ENGINEERING			
WOVEN WIRE RIGHT-OF-WAY FENCE TYPE 1			
STANDARD DRAWING NO.	312		
APPROVED	5/1/62		
DRAWN BY			
CHECKED BY			
DATE			

LEXINGTON-FAYETTE URBAN COUNTY GOVERNMENT, DEPARTMENT OF PUBLIC WORKS AND DEVELOPMENT

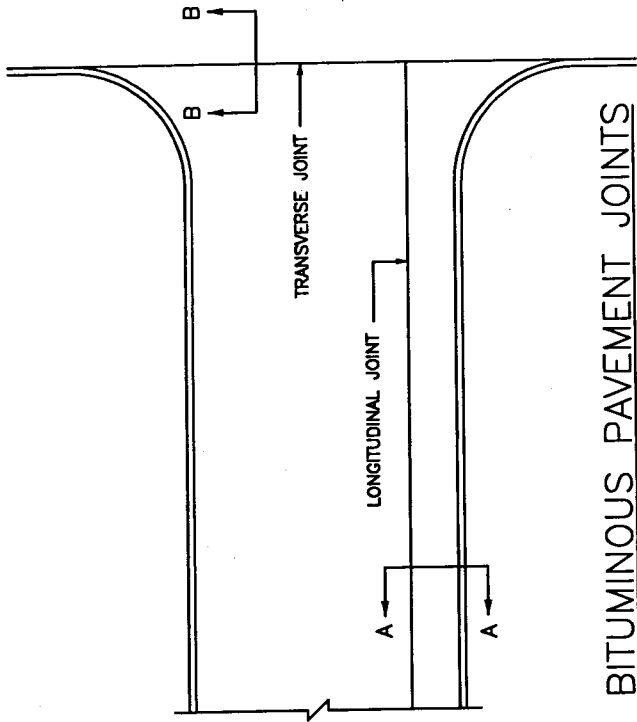

BITUMINOUS PAVEMENT JOINTS

NOTES:

1. ALL SAW-CUTS SHALL BE NEAT AND STRAIGHT.
2. IMMEDIATELY BEFORE LAYING NEW BITUMINOUS COURSES, ALL SAW CUT EDGES SHALL BE CLEANED OF DUST AND DEBRIS AND SPRAYED WITH A BITUMINOUS TACK COAT.
3. EDGE KEY SHALL NOT BE REQUIRED IF BOTH EXISTING AND NEW PAVEMENT ARE TO RECEIVE AN OVERLAY AS PART OF THIS CONTRACT.

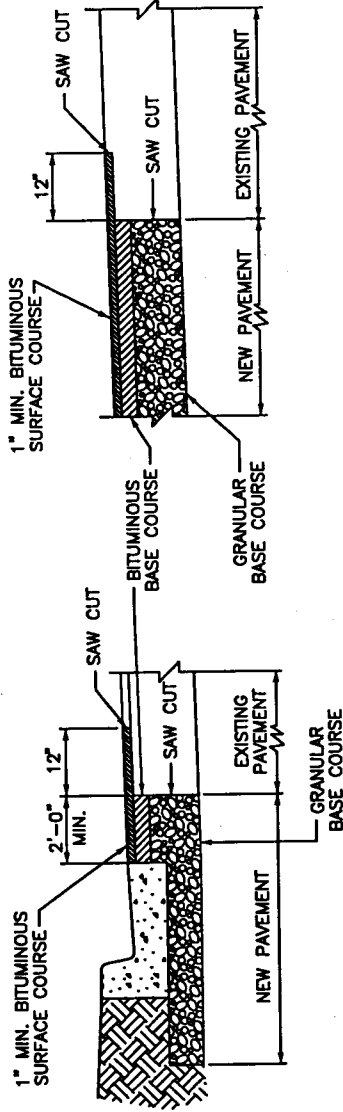

SECTION A-A

LONGITUDINAL EDGE KEY

SECTION B-B

TRANSVERSE EDGE KEY

NO.	DATE	REVISION DESCRIPTION	BY

DIVISION OF ENGINEERING

EDGE KEY

STANDARD DRAWING NO.	318
APPROVED	<i>[Signature]</i>
DATE	5/1/00
COMMISSIONER	<i>[Signature]</i>
DATE	5/1/00

Appendix B-1
Federal Wage Rates

General Decision Number: KY160100 03/25/2016 KY100

Superseded General Decision Number: KY20150100

State: Kentucky

Construction Type: Highway

Counties: Anderson, Bath, Bourbon, Boyd, Boyle, Bracken, Breckinridge, Bullitt, Carroll, Carter, Clark, Elliott, Fayette, Fleming, Franklin, Gallatin, Grant, Grayson, Greenup, Hardin, Harrison, Henry, Jefferson, Jessamine, Larue, Lewis, Madison, Marion, Mason, Meade, Mercer, Montgomery, Nelson, Nicholas, Oldham, Owen, Robertson, Rowan, Scott, Shelby, Spencer, Trimble, Washington and Woodford Counties in Kentucky.

HIGHWAY CONSTRUCTION PROJECTS (excluding tunnels, building structures in rest area projects & railroad construction; bascule, suspension & spandrel arch bridges designed for commercial navigation, bridges involving marine construction; and other major bridges).

Note: Under Executive Order (EO) 13658, an hourly minimum wage of \$10.15 for calendar year 2016 applies to all contracts subject to the Davis-Bacon Act for which the solicitation was issued on or after January 1, 2015. If this contract is covered by the EO, the contractor must pay all workers in any classification listed on this wage determination at least \$10.15 (or the applicable wage rate listed on this wage determination, if it is higher) for all hours spent performing on the contract in calendar year 2016. The EO minimum wage rate will be adjusted annually. Additional information on contractor requirements and worker protections under the EO is available at www.dol.gov/whd/govcontracts.

Modification Number	Publication Date
0	01/08/2016
1	02/19/2016
2	03/25/2016

BRIN004-003 06/01/2011

BRECKENRIDGE COUNTY

	Rates	Fringes
BRICKLAYER.....	\$ 24.11	10.07

BRKY001-005 06/01/2015

BULLITT, CARROLL, GRAYSON, HARDIN, HENRY, JEFFERSON, LARUE, MARION, MEADE, NELSON, OLDHAM, SHELBY, SPENCER, & TRIMBLE COUNTIES:

	Rates	Fringes
BRICKLAYER.....	\$ 25.96	10.64

BRKY0002-006 06/01/2011

BRACKEN, GALLATIN, GRANT, MASON & ROBERTSON COUNTIES:

	Rates	Fringes
BRICKLAYER.....	\$ 26.57	10.26

BRKY0007-004 06/01/2015

BOYD, CARTER, ELLIOT, FLEMING, GREENUP, LEWIS & ROWAN COUNTIES:

	Rates	Fringes
BRICKLAYER.....	\$ 31.38	18.10

BRKY0017-004 06/01/2015

ANDERSON, BATH, BOURBON, BOYLE, CLARK, FAYETTE, FRANKLIN,
HARRISON, JESSAMINE, MADISON, MERCER, MONTGOMERY, NICHOLAS,
OWEN, SCOTT, WASHINGTON & WOODFORD COUNTIES:

	Rates	Fringes
BRICKLAYER.....	\$ 24.79	11.72

CARP0064-001 05/01/2015

	Rates	Fringes
CARPENTER.....	\$ 27.50	16.06
Diver.....	\$ 41.63	16.06
PILEDRIVERMAN.....	\$ 27.75	16.06

ELEC0212-008 06/01/2015

BRACKEN, GALLATIN and GRANT COUNTIES

	Rates	Fringes
ELECTRICIAN.....	\$ 27.03	17.02

ELEC0212-014 12/01/2014

BRACKEN, GALLATIN & GRANT COUNTIES:

	Rates	Fringes
Sound & Communication Technician.....	\$ 22.75	10.08

ELEC0317-012 05/28/2014

BOYD, CARTER, ELLIOT & ROWAN COUNTIES:

	Rates	Fringes
ELECTRICIAN Cable Splicer.....	\$ 32.68	18.13

Electrician.....\$ 32.62 21.45

ELEC0369-007 05/27/2015

ANDERSON, BATH, BOURBON, BOYLE, BRECKINRIDGE, BULLITT, CARROLL, CLARK, FAYETTE, FRAONKLIN, GRAYSON, HARDIN, HARRISON, HENRY, JEFFERSON, JESSAMINE, LARUE, MADISON, MARION, MEADE, MERCER, MONTGOMERY, NELSON, NICHOLAS, OLDHAM, OWEN, ROBERTSON, SCOTT, SHELBY, SPENCER, TRIMBLE, WASHINGTON, & WOODFORD COUNTIES:

Rates Fringes

ELECTRICIAN.....\$ 30.01 15.65

ELEC0575-002 06/02/2014

FLEMING, GREENUP, LEWIS & MASON COUNTIES:

Rates Fringes

ELECTRICIAN.....\$ 31.70 14.21

ENGI0181-018 07/01/2015

Rates Fringes

POWER EQUIPMENT OPERATOR

GROUP 1.....\$ 29.95 14.40
GROUP 2.....\$ 27.26 14.40
GROUP 3.....\$ 27.68 14.40
GROUP 4.....\$ 26.96 14.40

OPERATING ENGINEER CLASSIFICATIONS

GROUP 1 - A-Frame Winch Truck; Auto Patrol; Backfiller; Batcher Plant; Bituminous Paver; Bituminous Transfer Machine; Boom Cat; Bulldozer; Mechanic; Cableway; Carry-All Scoop; Carry Deck Crane; Central Compressor Plant; Cherry Picker; Clamshell; Concrete Mixer (21 cu. ft. or Over); Concrete Paver; Truck-Mounted Concrete Pump; Core Drill; Crane; Crusher Plant; Derrick; Derrick Boat; Ditching & Trenching Machine; Dragline; Dredge Operator; Dredge Engineer; Elevating Grader & Loaders; Grade-All; Gurries; Heavy Equipment Robotics Operator/Mechanic; High Lift; Hoe-Type Machine; Hoist (Two or More Drums); Hoisting Engine (Two or More Drums); Horizontal Directional Drill Operator; Hydrocrane; Hyster; KeCal Loader; LeTourneau; Locomotive; Mechanic; Mechanically Operated Laser Screed; Mechanic Welder; Mucking Machine; Motor Scraper; Orangepeel Bucket; Overhead Crane; Piledriver; Power Blade; Pumpcrete; Push Dozer; Rock Spreader, attached to equipment; Rotary Drill; Roller (Bituminous); Rough Terrain Crane; Scarifier; Scoopmobile; Shovel; Side Boom; Subgrader; Tailboom; Telescoping Type Forklift; Tow or Push Boat; Tower Crane (French, German & other types); Tractor Shovel; Truck Crane; Tunnel Mining Machines, including Moles, Shields or similar types of Tunnel Mining Equipment

GROUP 2 - Air Compressor (Over 900 cu. ft. per min.); Bituminous Mixer; Boom Type Tamping Machine; Bull Float;

Concrete Mixer (Under 21 cu. ft.); Dredge Engineer;
 Electric Vibrator; Compactor/Self-Propelled Compactor;
 Elevator (One Drum or Buck Hoist); Elevator (When used to
 Hoist Building Material); Finish Machine; Firemen & Hoist
 (One Drum); Flexplane; Forklift (Regardless of Lift
 Height); Form Grader; Joint Sealing Machine; Outboard Motor
 Boat; Power Sweeper (Riding Type); Roller (Rock); Ross
 Carrier; Skid Mounted or Trailer Mounted Concrete Pump; Skid
 Steer Machine with all Attachments; Switchman or Brakeman;
 Throttle Valve Person; Tractair & Road Widening Trencher;
 Tractor (50 H.P. or Over); Truck Crane Oiler; Tugger;
 Welding Machine; Well Points; & Whirley Oiler

GROUP 3 - All Off Road Material Handling Equipment,
 including Articulating Dump Trucks; Greaser on Grease
 Facilities servicing Heavy Equipment

GROUP 4 - Bituminous Distributor; Burlap & Curing Machine;
 Cement Gun; Concrete Saw; Conveyor; Deckhand Oiler; Grout
 Pump; Hydraulic Post Driver; Hydro Seeder; Mud Jack; Oiler;
 Paving Joint Machine; Power Form Handling Equipment; Pump;
 Roller (Earth); Steerman; Tamping Machine; Tractor (Under
 50 H.P.); & Vibrator

CRANES - with booms 150 ft. & Over (Including JIB), and where
 the length of the boom in combination with the length of
 the piling leads equals or exceeds 150 ft. - \$1.00 over
 Group 1 rate

EMPLOYEES ASSIGNED TO WORK BELOW GROUND LEVEL ARE TO BE PAID
 10%
 ABOVE BASIC WAGE RATE. THIS DOES NOT APPLY TO OPEN CUT WORK.

 IRON0044-009 06/01/2015

BRACKEN, GALLATIN, GRANT, HARRISON, ROBERTSON,
 BOURBON (Northern third, including Townships of Jackson,
 Millersburg, Ruddled Mills & Shawhan);
 CARROLL (Eastern third, including the Township of Ghent);
 FLEMING (Western part, excluding Townships of Beechburg, Colfax,
 Elizaville, Flemingsburg, Flemingsburg Junction, Foxport,
 Grange City, Hillsboro, Hilltop, Mount Carmel, Muses Mills,
 Nepton, Pecksridge, Plummers Landing, Plummers Mill, Poplar
 Plains, Ringos Mills, Tilton & Wallingford);
 MASON (Western two-thirds, including Townships of Dover,
 Lewisburg, Mays Lick, Maysville, Minerva, Moranburg,
 Murphysville, Ripley, Sardis, Shannon, South Ripley &
 Washington);
 NICHOLAS (Townships of Barefoot, Barterville, Carlisle,
 Ellisville, Headquarters, Henryville, Morningglory, Myers &
 Oakland Mills);
 OWEN (Townships of Beechwood, Bromley, Fairbanks, Holbrook,
 Jonesville, Long Ridge, Lusby's Mill, New, New Columbus, New
 Liberty, Owenton, Poplar Grove, Rockdale, Sanders, Teresita &
 Wheatley);
 SCOTT (Northern two-thirds, including Townships of Biddle,
 Davis, Delaplain, Elmville, Longlick, Muddy Ford, Oxford,
 Rogers Gap, Sadieville, Skinnersburg & Stonewall)

Rates Fringes

IRONWORKER

Fence Erector.....	\$ 23.76	19.15
Structural.....	\$ 26.40	19.15

IRON0070-006 06/01/2015

ANDERSON, BOYLE, BRECKINRIDGE, BULLITT, FAYETTE, FRANKLIN,
 GRAYSON, HARDIN, HENRY, JEFFERSON, JESSAMINE, LARUE, MADISON,
 MARION, MEADE, MERCER, NELSON, OLDHAM, SHELBY, SPENCER,
 TRIMBLE, WASHINGTON & WOODFORD
 BOURBON (Southern two-thirds, including Townships of Austerlity,
 Centerville, Clintonville, Elizabeth, Hutchison, Littlerock,
 North Middletown & Paris);
 CARROLL (Western two-thirds, including Townships of Carrollton,
 Easterday, English, Locust, Louis, Prestonville & Worthville);
 CLARK (Western two-thirds, including Townships of Becknerville,
 Flanagan, Ford, Pine Grove, Winchester & Wyandotte);
 OWEN (Eastern eighth, including Townships of Glenmary, Gratz,
 Monterey, Perry Park & Tacketts Mill);
 SCOTT (Southern third, including Townships of Georgetown, Great
 Crossing, Newtown, Stampling Ground & Woodlake);

Rates Fringes

IRONWORKER.....	\$ 27.56	20.30
-----------------	----------	-------

IRON0372-006 06/15/2015

BRACKEN, GALLATIN, GRANT, HARRISON and ROBERTSON
 BOURBON (Northern third, including Townships of Jackson,
 Millersburg, Ruddel Mills & Shawhan);
 CARROLL (Eastern third, including the Township of Ghent);
 FLEMING (Western part, Excluding Townships of Beechburg, Colfax,
 Elizaville, Flemingsburg, Flemingsburg Junction, Foxport,
 Grange City, Hillsboro, Hilltop, Mount Carmel, Muses Mills,
 Nepton, Pecksridge, Plummers Landing, Plummers Mill, Poplar
 Plains,
 Ringos Mills, Tilton & Wallingford);
 MASON (Western two-thirds, including Townships of Dover,
 Lewisburg, Mays Lick, Maysville, Minerva, Moranburg,
 Murphysville, Ripley, Sardis, Shannon, South Ripley &
 Washington);
 NICHOLAS (Townships of Barefoot, Barterville, Carlisle,
 Ellisville, Headquarters, Henryville, Morningglory, Myers &
 Oakland Mills);
 OWEN (Townships of Beechwood, Bromley, Fairbanks, Holbrook,
 Jonesville, Long Ridge, Lusby's Mill, New, New Columbus, New
 Liberty, Owenton, Poplar Grove, Rockdale, Sanders, Teresita &
 Wheatley);
 SCOTT (Northern two-thirds, including Townships of Biddle,
 Davis, Delaplain, Elmville, Longlick, Muddy Ford, Oxford, Rogers
 Gap, Sadieville, Skinnersburg & Stonewall) COUNTIES

Rates Fringes

IRONWORKER, REINFORCING.....	\$ 27.00	19.00
------------------------------	----------	-------

IRON0769-007 06/01/2015

BATH, BOYD, CARTER, ELLIOTT, GREENUP, LEWIS, MONTGOMERY & ROWAN
 CLARK (Eastern third, including townships of Bloomingdale,
 Hunt, Indian Fields, Kiddville, Loglick, Rightangele & Thomson);
 FLEMING (Townships of Beechburg, Colfax, Elizaville,
 Flemingsburg, Flemingsburg Junction, Foxport, Grange City,
 Hillsboro, Hilltop, Mount Carmel, Muses Mills, Nepton,
 Pecksridge, Plummers Landing, Plummers Mill, Poplar Plains,
 Ringos Mills, Tilton & Wallingford);
 MASON (Eastern third, including Townships of Helena, Marshall,
 Orangeburg, Plumville & Springdale);
 NICHOLAS (Eastern eighth, including the Township of Moorefield
 Sprout)

	Rates	Fringes
IRONWORKER		
ZONE 1.....	\$ 31.33	22.39
ZONE 2.....	\$ 31.73	22.39
ZONE 3.....	\$ 33.33	22.39

ZONE 1 - Up to 10 mile radius of Union Hall, Ashland, Ky.,
 1643 Greenup Ave.

ZONE 2 - 10 to 50 mile radius of Union Hall, Ashland, Ky.,
 1643 Greenup Ave.

ZONE 3 - 50 mile radius & over of Union Hall, Ashland, Ky.,
 1643 Greenup Ave.

 LABO0189-003 07/01/2015

BATH, BOURBON, BOYD, BOYLE, BRACKEN, CARTER, CLARK, ELLIOTT,
 FAYETTE, FLEMING, FRANKLIN, GALLATIN, GRANT, GREENUP, HARRISON,
 JESSAMINE, LEWIS, MADISON, MASON, MERCER, MONTGOMERY, NICHOLAS,
 OWEN, ROBERTSON, ROWAN, SCOTT, & WOOLFORD COUNTIES

	Rates	Fringes
Laboers:		
GROUP 1.....	\$ 22.30	12.46
GROUP 2.....	\$ 22.55	12.46
GROUP 3.....	\$ 22.60	12.46
GROUP 4.....	\$ 23.20	12.46

LABORERS CLASSIFICATIONS

GROUP 1 - Aging & Curing of Concrete; Asbestos Abatement
 Worker; Asphalt Plant; Asphalt; Batch Truck Dump; Carpenter
 Tender; Cement Mason Tender; Cleaning of Machines;
 Concrete; Demolition; Dredging; Environmental - Nuclear,
 Radiation, Toxic & Hazardous Waste - Level D; Flagperson;
 Grade Checker; Hand Digging & Hand Back Filling; Highway
 Marker Placer; Landscaping, Mesh Handler & Placer; Puddler;
 Railroad; Rip-rap & Grouter; Right-of-Way; Sign, Guard Rail
 & Fence Installer; Signal Person; Sound Barrier Installer;
 Storm & Sanitary Sewer; Swamper; Truck Spotter & Dumper;

Wrecking of Concrete Forms; General Cleanup

GROUP 2 - Batter Board Man (Sanitary & Storm Sewer); Brickmason Tender; Mortar Mixer Operator; Scaffold Builder; Burner & Welder; Bushhammer; Chain Saw Operator; Concrete Saw Operator; Deckhand Scow Man; Dry Cement Handler; Environmental - Nuclear, Radiation, Toxic & Hazardous Waste - Level C; Forklift Operator for Masonary; Form Setter; Green Concrete Cutting; Hand Operated Grouter & Grinder Machine Operator; Jackhammer; Pavement Breaker; Paving Joint Machine; Pipelayer; Plastic Pipe Fusion; Power Driven Georgia Buggy & Wheel Barrow; Power Post Hole Digger; Precast Manhole Setter; Walk-Behind Tamper; Walk-Behind Trencher; Sand Blaster; Concrete Chipper; Surface Grinder; Vibrator Operator; Wagon Driller

GROUP 3 - Asphalt Luteman & Raker; Gunnite Nozzleman; Gunnite Operator & Mixer; Grout Pump Operator; Side Rail Setter; Rail Paved Ditches; Screw Operator; Tunnel (Free Air); Water Blaster

GROUP 4 - Caisson Worker (Free Air); Cement Finisher; Environmental - Nuclear, Radiation, Toxic & Hazardous Waste - Levels A & B; Miner & Driller (Free Air); Tunnel Blaster; & Tunnel Mucker (Free Air); Directional & Horizontal Boring; Air Track Drillers (All Types); Powdermen & Blasters; Troxler & Concrete Tester if Laborer is Utilized

LAB00189-008 07/01/2014

ANDERSON, BULLITT, CARROLL, HARDIN, HENRY, JEFFERSON, LARUE, MARION, MEADE, NELSON, OLDHAM, SHELBY, SPENCER, TRIMBLE & WASHINGTON COUNTIES

	Rates	Fringes
Laborers:		
GROUP 1.....	\$ 22.71	11.05
GROUP 2.....	\$ 22.96	11.05
GROUP 3.....	\$ 23.01	11.05
GROUP 4.....	\$ 23.61	11.05

LABORERS CLASSIFICATIONS

GROUP 1 - Aging & Curing of Concrete; Asbestos Abatement Worker; Asphalt Plant; Asphalt; Batch Truck Dump; Carpenter Tender; Cement Mason Tender; Cleaning of Machines; Concrete; Demolition; Dredging; Environmental - Nuclear, Radiation, Toxic & Hazardous Waste - Level D; Flagperson; Grade Checker; Hand Digging & Hand Back Filling; Highway Marker Placer; Landscaping, Mesh Handler & Placer; Puddler; Railroad; Rip-rap & Grouter; Right-of-Way; Sign, Guard Rail & Fence Installer; Signal Person; Sound Barrier Installer; Storm & Sanitary Sewer; Swamper; Truck Spotter & Dumper; Wrecking of Concrete Forms; General Cleanup

GROUP 2 - Batter Board Man (Sanitary & Storm Sewer); Brickmason Tender; Mortar Mixer Operator; Scaffold Builder; Burner & Welder; Bushhammer; Chain Saw Operator; Concrete

Saw Operator; Deckhand Scow Man; Dry Cement Handler;
 Environmental - Nuclear, Radiation, Toxic & Hazardous Waste
 - Level C; Forklift Operator for Masonary; Form Setter;
 Green Concrete Cutting; Hand Operated Grouter & Grinder
 Machine Operator; Jackhammer; Pavement Breaker; Paving
 Joint Machine; Pipelayer; Plastic Pipe Fusion; Power Driven
 Georgia Buggy & Wheel Barrow; Power Post Hole Digger;
 Precast Manhole Setter; Walk-Behind Tamper; Walk-Behind
 Trencher; Sand Blaster; Concrete Chipper; Surface Grinder;
 Vibrator Operator; Wagon Driller

GROUP 3 - Asphalt Luteman & Raker; Gunnite Nozzleman;
 Gunnite Operator & Mixer; Grout Pump Operator; Side Rail
 Setter; Rail Paved Ditches; Screw Operator; Tunnel (Free
 Air); Water Blaster

GROUP 4 - Caisson Worker (Free Air); Cement Finisher;
 Environmental - Nuclear, Radiation, Toxic & Hazardous Waste
 - Levels A & B; Miner & Driller (Free Air); Tunnel Blaster;
 & Tunnel Mucker (Free Air); Directional & Horizontal
 Boring; Air Track Drillers (All Types); Powdermen &
 Blasters; Troxler & Concrete Tester if Laborer is Utilized

 LAB00189-009 07/01/2014

BRECKINRIDGE & GRAYSON COUNTIES

	Rates	Fringes
Laborers:		
GROUP 1.....	\$ 22.66	11.10
GROUP 2.....	\$ 22.91	11.10
GROUP 3.....	\$ 22.96	11.10
GROUP 4.....	\$ 23.56	11.10

LABORERS CLASSIFICATIONS

GROUP 1 - Aging & Curing of Concrete; Asbestos Abatement
 Worker; Asphalt Plant; Asphalt; Batch Truck Dump; Carpenter
 Tender; Cement Mason Tender; Cleaning of Machines;
 Concrete; Demolition; Dredging; Environmental - Nuclear,
 Radiation, Toxic & Hazardous Waste - Level D; Flagperson;
 Grade Checker; Hand Digging & Hand Back Filling; Highway
 Marker Placer; Landscaping, Mesh Handler & Placer; Puddler;
 Railroad; Rip-rap & Grouter; Right-of-Way; Sign, Guard Rail
 & Fence Installer; Signal Person; Sound Barrier Installer;
 Storm & Sanitary Sewer; Swamper; Truck Spotter & Dumper;
 Wrecking of Concrete Forms; General Cleanup

GROUP 2 - Batter Board Man (Sanitary & Storm Sewer);
 Brickmason Tender; Mortar Mixer Operator; Scaffold Builder;
 Burner & Welder; Bushhammer; Chain Saw Operator; Concrete
 Saw Operator; Deckhand Scow Man; Dry Cement Handler;
 Environmental - Nuclear, Radiation, Toxic & Hazardous Waste
 - Level C; Forklift Operator for Masonary; Form Setter;
 Green Concrete Cutting; Hand Operated Grouter & Grinder
 Machine Operator; Jackhammer; Pavement Breaker; Paving
 Joint Machine; Pipelayer; Plastic Pipe Fusion; Power Driven
 Georgia Buggy & Wheel Barrow; Power Post Hole Digger;
 Precast Manhole Setter; Walk-Behind Tamper; Walk-Behind

Trencher; Sand Blaster; Concrete Chipper; Surface Grinder; Vibrator Operator; Wagon Driller

GROUP 3 - Asphalt Lutean & Raker; Gunnite Nozzleman; Gunnite Operator & Mixer; Grout Pump Operator; Side Rail Setter; Rail Paved Ditches; Screw Operator; Tunnel (Free Air); Water Blaster

GROUP 4 - Caisson Worker (Free Air); Cement Finisher; Environmental - Nuclear, Radiation, Toxic & Hazardous Waste - Levels A & B; Miner & Driller (Free Air); Tunnel Blaster; & Tunnel Mucker (Free Air); Directional & Horizontal Boring; Air Track Drillers (All Types); Powdermen & Blasters; Troxler & Concrete Tester if Laborer is Utilized

PAIN0012-005 06/11/2005

BATH, BOURBON, BOYLE, CLARK, FAYETTE, FLEMING, FRANKLIN, HARRISON, JESSAMINE, MADISON, MERCER, MONTGOMERY, NICHOLAS, ROBERTSON, SCOTT & WOODFORD COUNTIES:

	Rates	Fringes
PAINTER		
Bridge/Equipment Tender and/or Containment Builder..	\$ 18.90	5.90
Brush & Roller.....	\$ 21.30	5.90
Elevated Tanks; Steeplejack Work; Bridge & Lead Abatement.....	\$ 22.30	5.90
Sandblasting & Waterblasting.....	\$ 22.05	5.90
Spray.....	\$ 21.80	5.90

PAIN0012-017 05/01/2015

BRACKEN, GALLATIN, GRANT, MASON & OWEN COUNTIES:

	Rates	Fringes
PAINTER (Heavy & Highway Bridges - Guardrails - Lightpoles - Striping)		
Bridge Equipment Tender and Containment Builder.....	\$ 20.73	9.06
Brush & Roller.....	\$ 23.39	9.06
Elevated Tanks; Steeplejack Work; Bridge & Lead Abatement.....	\$ 24.39	9.06
Sandblasting & Water Blasting.....	\$ 24.14	9.06
Spray.....	\$ 23.89	9.06

PAIN0118-004 06/01/2014

ANDERSON, BRECKINRIDGE, BULLITT, CARROLL, GRAYSON, HARDIN, HENRY, JEFFERSON, LARUE, MARION, MEADE, NELSON, OLDHAM, SHELBY, SPENCER, TRIMBLE & WASHINGTON COUNTIES:

	Rates	Fringes
PAINTER		
Brush & Roller.....	\$ 18.50	11.97
Spray, Sandblast, Power Tools, Waterblast & Steam Cleaning.....	\$ 19.50	11.97

PAIN1072-003 12/01/2015

BOYD, CARTER, ELLIOTT, GREENUP, LEWIS and ROWAN COUNTIES

	Rates	Fringes
Painters:.....		
Bridges; Locks; Dams; Tension Towers & Energized Substations.....	\$ 29.39	14.27
Power Generating Facilities.....	\$ 31.83	15.30
	\$ 28.59	15.30

PLUM0248-003 06/01/2015

BOYD, CARTER, ELLIOTT, GREENUP, LEWIS & ROWAN COUNTIES:

	Rates	Fringes
Plumber and Steamfitter.....	\$ 34.00	19.04

PLUM0392-007 06/01/2014

BRACKEN, CARROLL (Eastern Half), GALLATIN, GRANT, MASON, OWEN & ROBERTSON COUNTIES:

	Rates	Fringes
Plumbers and Pipefitters.....	\$ 29.80	17.79

* PLUM0502-003 08/01/2015

BRECKINRIDGE, BULLITT, CARROLL (Western Half), FRANKLIN (Western three-fourths), GRAYSON, HARDIN, HENRY, JEFFERSON, LARUE, MARION, MEADE, NELSON, OLDHAM, SHELBY, SPENCER, TRIMBLE & WASHINGTON COUNTIES

	Rates	Fringes
PLUMBER.....	\$ 32.00	19.13

SUKY2010-160 10/08/2001

	Rates	Fringes
Truck drivers:		
GROUP 1.....	\$ 16.57	7.34
GROUP 2.....	\$ 16.68	7.34
GROUP 3.....	\$ 16.86	7.34
GROUP 4.....	\$ 16.96	7.34

TRUCK DRIVER CLASSIFICATIONS

GROUP 1 - Mobile Batch Truck Tender

GROUP 2 - Greaser; Tire Changer; & Mechanic Tender

GROUP 3 - Single Axle Dump; Flatbed; Semi-trailer or Pole Trailer when used to pull building materials and equipment; Tandem Axle Dump; Distributor; Mixer; & Truck Mechanic

GROUP 4 - Euclid & Other Heavy Earthmoving Equipment & Lowboy; Articulator Cat; 5-Axle Vehicle; Winch & A-Frame when used in transporting materials; Ross Carrier; Forklift when used to transport building materials; & Pavement Breaker

WELDERS - Receive rate prescribed for craft performing operation to which welding is incidental.

=====

Unlisted classifications needed for work not included within the scope of the classifications listed may be added after award only as provided in the labor standards contract clauses (29CFR 5.5 (a) (1) (ii)).

The body of each wage determination lists the classification and wage rates that have been found to be prevailing for the cited type(s) of construction in the area covered by the wage determination. The classifications are listed in alphabetical order of "identifiers" that indicate whether the particular rate is a union rate (current union negotiated rate for local), a survey rate (weighted average rate) or a union average rate (weighted union average rate).

Union Rate Identifiers

A four letter classification abbreviation identifier enclosed in dotted lines beginning with characters other than "SU" or "UAVG" denotes that the union classification and rate were prevailing for that classification in the survey. Example: PLUM0198-005 07/01/2014. PLUM is an abbreviation identifier of the union which prevailed in the survey for this classification, which in this example would be Plumbers. 0198 indicates the local union number or district council number where applicable, i.e., Plumbers Local 0198. The next number, 005 in the example, is an internal number used in processing the wage determination. 07/01/2014 is the effective date of the most current negotiated rate, which in this example is July 1, 2014.

Union prevailing wage rates are updated to reflect all rate changes in the collective bargaining agreement (CBA) governing this classification and rate.

Survey Rate Identifiers

Classifications listed under the "SU" identifier indicate that no one rate prevailed for this classification in the survey and the published rate is derived by computing a weighted average rate based on all the rates reported in the survey for that classification. As this weighted average rate includes all rates reported in the survey, it may include both union and non-union rates. Example: SULA2012-007 5/13/2014. SU indicates the rates are survey rates based on a weighted average calculation of rates and are not majority rates. LA indicates the State of Louisiana. 2012 is the year of survey on which these classifications and rates are based. The next number, 007 in the example, is an internal number used in producing the wage determination. 5/13/2014 indicates the survey completion date for the classifications and rates under that identifier.

Survey wage rates are not updated and remain in effect until a new survey is conducted.

Union Average Rate Identifiers

Classification(s) listed under the UAVG identifier indicate that no single majority rate prevailed for those classifications; however, 100% of the data reported for the classifications was union data. EXAMPLE: UAVG-OH-0010 08/29/2014. UAVG indicates that the rate is a weighted union average rate. OH indicates the state. The next number, 0010 in the example, is an internal number used in producing the wage determination. 08/29/2014 indicates the survey completion date for the classifications and rates under that identifier.

A UAVG rate will be updated once a year, usually in January of each year, to reflect a weighted average of the current negotiated/CBA rate of the union locals from which the rate is based.

WAGE DETERMINATION APPEALS PROCESS

1.) Has there been an initial decision in the matter? This can be:

- * an existing published wage determination
- * a survey underlying a wage determination
- * a Wage and Hour Division letter setting forth a position on a wage determination matter
- * a conformance (additional classification and rate) ruling

On survey related matters, initial contact, including requests for summaries of surveys, should be with the Wage and Hour Regional Office for the area in which the survey was conducted because those Regional Offices have responsibility for the Davis-Bacon survey program. If the response from this initial contact is not satisfactory, then the process described in 2.) and 3.) should be followed.

With regard to any other matter not yet ripe for the formal process described here, initial contact should be with the Branch of Construction Wage Determinations. Write to:

Branch of Construction Wage Determinations
Wage and Hour Division
U.S. Department of Labor
200 Constitution Avenue, N.W.
Washington, DC 20210

2.) If the answer to the question in 1.) is yes, then an interested party (those affected by the action) can request review and reconsideration from the Wage and Hour Administrator (See 29 CFR Part 1.8 and 29 CFR Part 7). Write to:

Wage and Hour Administrator
U.S. Department of Labor
200 Constitution Avenue, N.W.
Washington, DC 20210

The request should be accompanied by a full statement of the interested party's position and by any information (wage payment data, project description, area practice material, etc.) that the requestor considers relevant to the issue.

3.) If the decision of the Administrator is not favorable, an interested party may appeal directly to the Administrative Review Board (formerly the Wage Appeals Board). Write to:

Administrative Review Board
U.S. Department of Labor
200 Constitution Avenue, N.W.
Washington, DC 20210

4.) All decisions by the Administrative Review Board are final.

=====
END OF GENERAL DECISION

Appendix C

KYTC Approved Traffic Management Plan

KENTUCKY TRANSPORTATION CABINET DEPARTMENT OF HIGHWAYS TRAFFIC MANAGEMENT PLAN

County: Fayette Item No.: 7-428.00

Federal Project No.: STPM 3003-290

Project Description:

Man O War Boulevard Public Improvement Project Richmond Road Intersection

Roadway Classification: Urban Rural
 Local Collector Arterial Interstate

ADT (current) 33,400 AM Peak Current _____ PM Peak Current _____ % Trucks _____

Project Designation: Significant Other: LPA

Traffic Control Plan Design:

Taper and Diversion Design Speeds na

Minimum Lane Width 11 Minimum Shoulder Width 0

Minimum Bridge Width na

Minimum Radius _____ Maximum Grade _____

Minimum Taper Length _____ Minimum Intersection Level of Service _____

Existing Traffic Queue Lengths _____ Projected Traffic Queue Lengths _____

Comments:

**KENTUCKY TRANSPORTATION CABINET
DEPARTMENT OF HIGHWAYS
TRAFFIC MANAGEMENT PLAN**

Item No. 7-428

Discussion:

1) Public Information Plan	
a) Prepare with assistance from <input type="checkbox"/> KYTC or <input checked="" type="checkbox"/> LFUCG	
b) Identify Trip Generators Referenced	f) Railroad Involvement N/A
c) Identify Types of Road Users Referenced	g) Address Pedestrians, Bikes Mass Transit Referenced
d) Public Information Message Referenced	h) Address Timing, Frequency, Updates, Effectiveness of Plan Referenced
e) Public Information Strategies to be used Referenced	i) Police & Other Emergency Services Referenced

**KENTUCKY TRANSPORTATION CABINET
DEPARTMENT OF HIGHWAYS
TRAFFIC MANAGEMENT PLAN**

Item No. 7-428

2) Temporary Traffic Control Plan (For Each Phase of Construction) Phase I	
Exposure Control Measures	Positive Protection Measures
a) Is Road Closure Allowed Type: Lane Referenced	a) Address Drop Off Protection Criteria Referenced
b) Detour Conditions Referenced	b) Temporary Barrier Requirements Referenced
c) Working Hour Restrictions Referenced	c) Evaluation of Existing Guardrail Conditions Referenced
d) Holiday or Special Event Work Restrictions Referenced	d) Address Temporary Drainage Referenced
e) Evaluation of Intersection LOS Referenced	Uniformed Law Enforcement Officers Referenced
f) Evaluation of Queue Lengths Referenced	Payment for Traffic Control*
g) Evaluation of User Costs and Incentives/Disincentives Referenced	a) Method of Project Bidding Referenced
h) Address Pedestrians, Bikes, Mass Transit Referenced	b) Special Notes Referenced
Work Vehicles and Equipment Referenced	*Payment for traffic control items shall be in accordance with the Kentucky Department of Highways Standard Specifications for Road and Bridge Construction
Comments:	
See Maintenance of Traffic Plan sheets	

**KENTUCKY TRANSPORTATION CABINET
DEPARTMENT OF HIGHWAYS
TRAFFIC MANAGEMENT PLAN**

Item No. 7-428

2) Temporary Traffic Control Plan (For Each Phase of Construction) Phase 2	
Exposure Control Measures	Positive Protection Measures
a) Is Road Closure Allowed Type: Lane Referenced	a) Address Drop Off Protection Criteria Referenced
b) Detour Conditions Referenced	b) Temporary Barrier Requirements Referenced
c) Working Hour Restrictions Referenced	c) Evaluation of Existing Guardrail Conditions Referenced
d) Holiday or Special Event Work Restrictions Referenced	d) Address Temporary Drainage Referenced
e) Evaluation of Intersection LOS Referenced	Uniformed Law Enforcement Officers Referenced
f) Evaluation of Queue Lengths Referenced	Payment for Traffic Control*
g) Evaluation of User Costs and Incentives/Disincentives Referenced	a) Method of Project Bidding Referenced
h) Address Pedestrians, Bikes, Mass Transit Referenced	b) Special Notes Referenced
Work Vehicles and Equipment Referenced	*Payment for traffic control items shall be in accordance with the Kentucky Department of Highways Standard Specifications for Road and Bridge Construction
Comments:	
See Maintenance of Traffic Plan sheets	

TRAFFIC MANAGEMENT PLAN
Supplemental Information

County: Fayette
Federal Project No: STPM 3003-290

Item No.: 7-428.00

Project Description: Man O' War Boulevard Public Improvement Project Richmond Road Intersection. Extend the length of the right turn lane of Man O' War (southbound) to Richmond Road.

MAINTENANCE OF TRAFFIC PLAN
Sheet R020

LFUCG POINT OF CONTACT: Brian Hayes, Division of Engineering, 859-258-3445

The Contractor shall appoint a Project Traffic Control Coordinator to monitor traffic control devices.

Contractor shall notify the LFUCG Division of Traffic Engineering 48 hours prior to installation of permanent or temporary traffic control devices or signal changes.

KENTUCKY TRANSPORTATION CABINET
DEPARTMENT OF HIGHWAYS
TRAFFIC MANAGEMENT PLAN

Item No. 7-428

APPROVAL:

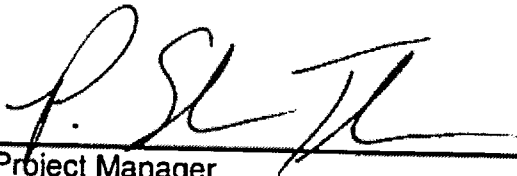
Project Manager _____ 8/30/17
Date

Project Delivery and Preservation Manager Date

Engineering Support Manager Date

FHWA Representative Date

Revisions to the TMP require review/approval by the signatories.

Appendix D

LPA Documents

FHWA 1273- Federal Aid Required Contract Provisions

23 CFR 635.109 Standardized Changed Conditions Clauses

KYTC Office of Local Programs Change Order Form

**REQUIRED CONTRACT PROVISIONS
FEDERAL-AID CONSTRUCTION CONTRACTS**

- I. General
- II. Nondiscrimination
- III. Nonsegregated Facilities
- IV. Davis-Bacon and Related Act Provisions
- V. Contract Work Hours and Safety Standards Act Provisions
- VI. Subletting or Assigning the Contract
- VII. Safety; Accident Prevention
- VIII. False Statements Concerning Highway Projects
- IX. Implementation of Clean Air Act and Federal Water Pollution Control Act
- X. Compliance with Governmentwide Suspension and Debarment Requirements
- XI. Certification Regarding Use of Contract Funds for Lobbying

ATTACHMENTS

A. Employment and Materials Preference for Appalachian Development Highway System or Appalachian Local Access Road Contracts (included in Appalachian contracts only)

I. GENERAL

1. Form FHWA-1273 must be physically incorporated in each construction contract funded under Title 23 (excluding emergency contracts solely intended for debris removal). The contractor (or subcontractor) must insert this form in each subcontract and further require its inclusion in all lower tier subcontracts (excluding purchase orders, rental agreements and other agreements for supplies or services).

The applicable requirements of Form FHWA-1273 are incorporated by reference for work done under any purchase order, rental agreement or agreement for other services. The prime contractor shall be responsible for compliance by any subcontractor, lower-tier subcontractor or service provider.

Form FHWA-1273 must be included in all Federal-aid design-build contracts, in all subcontracts and in lower tier subcontracts (excluding subcontracts for design services, purchase orders, rental agreements and other agreements for supplies or services). The design-builder shall be responsible for compliance by any subcontractor, lower-tier subcontractor or service provider.

Contracting agencies may reference Form FHWA-1273 in bid proposal or request for proposal documents, however, the Form FHWA-1273 must be physically incorporated (not referenced) in all contracts, subcontracts and lower-tier subcontracts (excluding purchase orders, rental agreements and other agreements for supplies or services related to a construction contract).

2. Subject to the applicability criteria noted in the following sections, these contract provisions shall apply to all work performed on the contract by the contractor's own organization and with the assistance of workers under the contractor's immediate superintendence and to all work performed on the contract by piecework, station work, or by subcontract.

3. A breach of any of the stipulations contained in these Required Contract Provisions may be sufficient grounds for withholding of progress payments, withholding of final payment, termination of the contract, suspension / debarment or any other action determined to be appropriate by the contracting agency and FHWA.

4. Selection of Labor: During the performance of this contract, the contractor shall not use convict labor for any purpose within the limits of a construction project on a Federal-aid highway unless it is labor performed by convicts who are on parole, supervised release, or probation. The term Federal-aid highway does not include roadways functionally classified as local roads or rural minor collectors.

II. NONDISCRIMINATION

The provisions of this section related to 23 CFR Part 230 are applicable to all Federal-aid construction contracts and to all related construction subcontracts of \$10,000 or more. The provisions of 23 CFR Part 230 are not applicable to material supply, engineering, or architectural service contracts.

In addition, the contractor and all subcontractors must comply with the following policies: Executive Order 11246, 41 CFR 60, 29 CFR 1625-1627, Title 23 USC Section 140, the Rehabilitation Act of 1973, as amended (29 USC 794), Title VI of the Civil Rights Act of 1964, as amended, and related regulations including 49 CFR Parts 21, 26 and 27; and 23 CFR Parts 200, 230, and 633.

The contractor and all subcontractors must comply with: the requirements of the Equal Opportunity Clause in 41 CFR 60-1.4(b) and, for all construction contracts exceeding \$10,000, the Standard Federal Equal Employment Opportunity Construction Contract Specifications in 41 CFR 60-4.3.

Note: The U.S. Department of Labor has exclusive authority to determine compliance with Executive Order 11246 and the policies of the Secretary of Labor including 41 CFR 60, and 29 CFR 1625-1627. The contracting agency and the FHWA have the authority and the responsibility to ensure compliance with Title 23 USC Section 140, the Rehabilitation Act of 1973, as amended (29 USC 794), and Title VI of the Civil Rights Act of 1964, as amended, and related regulations including 49 CFR Parts 21, 26 and 27; and 23 CFR Parts 200, 230, and 633.

The following provision is adopted from 23 CFR 230, Appendix A, with appropriate revisions to conform to the U.S. Department of Labor (US DOL) and FHWA requirements.

1. Equal Employment Opportunity: Equal employment opportunity (EEO) requirements not to discriminate and to take affirmative action to assure equal opportunity as set forth under laws, executive orders, rules, regulations (28 CFR 35, 29 CFR 1630, 29 CFR 1625-1627, 41 CFR 60 and 49 CFR 27) and orders of the Secretary of Labor as modified by the provisions prescribed herein, and imposed pursuant to 23 U.S.C. 140 shall constitute the EEO and specific affirmative action standards for the contractor's project activities under

this contract. The provisions of the Americans with Disabilities Act of 1990 (42 U.S.C. 12101 et seq.) set forth under 28 CFR 35 and 29 CFR 1630 are incorporated by reference in this contract. In the execution of this contract, the contractor agrees to comply with the following minimum specific requirement activities of EEO:

a. The contractor will work with the contracting agency and the Federal Government to ensure that it has made every good faith effort to provide equal opportunity with respect to all of its terms and conditions of employment and in their review of activities under the contract.

b. The contractor will accept as its operating policy the following statement:

"It is the policy of this Company to assure that applicants are employed, and that employees are treated during employment, without regard to their race, religion, sex, color, national origin, age or disability. Such action shall include: employment, upgrading, demotion, or transfer; recruitment or recruitment advertising; layoff or termination; rates of pay or other forms of compensation; and selection for training, including apprenticeship, pre-apprenticeship, and/or on-the-job training."

2. EEO Officer: The contractor will designate and make known to the contracting officers an EEO Officer who will have the responsibility for and must be capable of effectively administering and promoting an active EEO program and who must be assigned adequate authority and responsibility to do so.

3. Dissemination of Policy: All members of the contractor's staff who are authorized to hire, supervise, promote, and discharge employees, or who recommend such action, or who are substantially involved in such action, will be made fully cognizant of, and will implement, the contractor's EEO policy and contractual responsibilities to provide EEO in each grade and classification of employment. To ensure that the above agreement will be met, the following actions will be taken as a minimum:

a. Periodic meetings of supervisory and personnel office employees will be conducted before the start of work and then not less often than once every six months, at which time the contractor's EEO policy and its implementation will be reviewed and explained. The meetings will be conducted by the EEO Officer.

b. All new supervisory or personnel office employees will be given a thorough indoctrination by the EEO Officer, covering all major aspects of the contractor's EEO obligations within thirty days following their reporting for duty with the contractor.

c. All personnel who are engaged in direct recruitment for the project will be instructed by the EEO Officer in the contractor's procedures for locating and hiring minorities and women.

d. Notices and posters setting forth the contractor's EEO policy will be placed in areas readily accessible to employees, applicants for employment and potential employees.

e. The contractor's EEO policy and the procedures to implement such policy will be brought to the attention of employees by means of meetings, employee handbooks, or other appropriate means.

4. Recruitment: When advertising for employees, the contractor will include in all advertisements for employees the notation: "An Equal Opportunity Employer." All such advertisements will be placed in publications having a large circulation among minorities and women in the area from which the project work force would normally be derived.

a. The contractor will, unless precluded by a valid bargaining agreement, conduct systematic and direct recruitment through public and private employee referral sources likely to yield qualified minorities and women. To meet this requirement, the contractor will identify sources of potential minority group employees, and establish with such identified sources procedures whereby minority and women applicants may be referred to the contractor for employment consideration.

b. In the event the contractor has a valid bargaining agreement providing for exclusive hiring hall referrals, the contractor is expected to observe the provisions of that agreement to the extent that the system meets the contractor's compliance with EEO contract provisions. Where implementation of such an agreement has the effect of discriminating against minorities or women, or obligates the contractor to do the same, such implementation violates Federal nondiscrimination provisions.

c. The contractor will encourage its present employees to refer minorities and women as applicants for employment. Information and procedures with regard to referring such applicants will be discussed with employees.

5. Personnel Actions: Wages, working conditions, and employee benefits shall be established and administered, and personnel actions of every type, including hiring, upgrading, promotion, transfer, demotion, layoff, and termination, shall be taken without regard to race, color, religion, sex, national origin, age or disability. The following procedures shall be followed:

a. The contractor will conduct periodic inspections of project sites to insure that working conditions and employee facilities do not indicate discriminatory treatment of project site personnel.

b. The contractor will periodically evaluate the spread of wages paid within each classification to determine any evidence of discriminatory wage practices.

c. The contractor will periodically review selected personnel actions in depth to determine whether there is evidence of discrimination. Where evidence is found, the contractor will promptly take corrective action. If the review indicates that the discrimination may extend beyond the actions reviewed, such corrective action shall include all affected persons.

d. The contractor will promptly investigate all complaints of alleged discrimination made to the contractor in connection with its obligations under this contract, will attempt to resolve such complaints, and will take appropriate corrective action within a reasonable time. If the investigation indicates that the discrimination may affect persons other than the complainant, such corrective action shall include such other persons. Upon completion of each investigation, the contractor will inform every complainant of all of their avenues of appeal.

6. Training and Promotion:

a. The contractor will assist in locating, qualifying, and increasing the skills of minorities and women who are

applicants for employment or current employees. Such efforts should be aimed at developing full journey level status employees in the type of trade or job classification involved.

b. Consistent with the contractor's work force requirements and as permissible under Federal and State regulations, the contractor shall make full use of training programs, i.e., apprenticeship, and on-the-job training programs for the geographical area of contract performance. In the event a special provision for training is provided under this contract, this subparagraph will be superseded as indicated in the special provision. The contracting agency may reserve training positions for persons who receive welfare assistance in accordance with 23 U.S.C. 140(a).

c. The contractor will advise employees and applicants for employment of available training programs and entrance requirements for each.

d. The contractor will periodically review the training and promotion potential of employees who are minorities and women and will encourage eligible employees to apply for such training and promotion.

7. Unions: If the contractor relies in whole or in part upon unions as a source of employees, the contractor will use good faith efforts to obtain the cooperation of such unions to increase opportunities for minorities and women. Actions by the contractor, either directly or through a contractor's association acting as agent, will include the procedures set forth below:

a. The contractor will use good faith efforts to develop, in cooperation with the unions, joint training programs aimed toward qualifying more minorities and women for membership in the unions and increasing the skills of minorities and women so that they may qualify for higher paying employment.

b. The contractor will use good faith efforts to incorporate an EEO clause into each union agreement to the end that such union will be contractually bound to refer applicants without regard to their race, color, religion, sex, national origin, age or disability.

c. The contractor is to obtain information as to the referral practices and policies of the labor union except that to the extent such information is within the exclusive possession of the labor union and such labor union refuses to furnish such information to the contractor, the contractor shall so certify to the contracting agency and shall set forth what efforts have been made to obtain such information.

d. In the event the union is unable to provide the contractor with a reasonable flow of referrals within the time limit set forth in the collective bargaining agreement, the contractor will, through independent recruitment efforts, fill the employment vacancies without regard to race, color, religion, sex, national origin, age or disability; making full efforts to obtain qualified and/or qualifiable minorities and women. The failure of a union to provide sufficient referrals (even though it is obligated to provide exclusive referrals under the terms of a collective bargaining agreement) does not relieve the contractor from the requirements of this paragraph. In the event the union referral practice prevents the contractor from meeting the obligations pursuant to Executive Order 11246, as amended, and these special provisions, such contractor shall immediately notify the contracting agency.

8. Reasonable Accommodation for Applicants / Employees with Disabilities: The contractor must be familiar

with the requirements for and comply with the Americans with Disabilities Act and all rules and regulations established there under. Employers must provide reasonable accommodation in all employment activities unless to do so would cause an undue hardship.

9. Selection of Subcontractors, Procurement of Materials and Leasing of Equipment: The contractor shall not discriminate on the grounds of race, color, religion, sex, national origin, age or disability in the selection and retention of subcontractors, including procurement of materials and leases of equipment. The contractor shall take all necessary and reasonable steps to ensure nondiscrimination in the administration of this contract.

a. The contractor shall notify all potential subcontractors and suppliers and lessors of their EEO obligations under this contract.

b. The contractor will use good faith efforts to ensure subcontractor compliance with their EEO obligations.

10. Assurance Required by 49 CFR 26.13(b):

a. The requirements of 49 CFR Part 26 and the State DOT's U.S. DOT-approved DBE program are incorporated by reference.

b. The contractor or subcontractor shall not discriminate on the basis of race, color, national origin, or sex in the performance of this contract. The contractor shall carry out applicable requirements of 49 CFR Part 26 in the award and administration of DOT-assisted contracts. Failure by the contractor to carry out these requirements is a material breach of this contract, which may result in the termination of this contract or such other remedy as the contracting agency deems appropriate.

11. Records and Reports: The contractor shall keep such records as necessary to document compliance with the EEO requirements. Such records shall be retained for a period of three years following the date of the final payment to the contractor for all contract work and shall be available at reasonable times and places for inspection by authorized representatives of the contracting agency and the FHWA.

a. The records kept by the contractor shall document the following:

(1) The number and work hours of minority and non-minority group members and women employed in each work classification on the project;

(2) The progress and efforts being made in cooperation with unions, when applicable, to increase employment opportunities for minorities and women; and

(3) The progress and efforts being made in locating, hiring, training, qualifying, and upgrading minorities and women;

b. The contractors and subcontractors will submit an annual report to the contracting agency each July for the duration of the project, indicating the number of minority, women, and non-minority group employees currently engaged in each work classification required by the contract work. This information is to be reported on Form FHWA-1391. The staffing data should represent the project work force on board in all or any part of the last payroll period preceding the end of July. If on-the-job training is being required by special provision, the contractor

will be required to collect and report training data. The employment data should reflect the work force on board during all or any part of the last payroll period preceding the end of July.

III. NONSEGREGATED FACILITIES

This provision is applicable to all Federal-aid construction contracts and to all related construction subcontracts of \$10,000 or more.

The contractor must ensure that facilities provided for employees are provided in such a manner that segregation on the basis of race, color, religion, sex, or national origin cannot result. The contractor may neither require such segregated use by written or oral policies nor tolerate such use by employee custom. The contractor's obligation extends further to ensure that its employees are not assigned to perform their services at any location, under the contractor's control, where the facilities are segregated. The term "facilities" includes waiting rooms, work areas, restaurants and other eating areas, time clocks, restrooms, washrooms, locker rooms, and other storage or dressing areas, parking lots, drinking fountains, recreation or entertainment areas, transportation, and housing provided for employees. The contractor shall provide separate or single-user restrooms and necessary dressing or sleeping areas to assure privacy between sexes.

IV. DAVIS-BACON AND RELATED ACT PROVISIONS

This section is applicable to all Federal-aid construction projects exceeding \$2,000 and to all related subcontracts and lower-tier subcontracts (regardless of subcontract size). The requirements apply to all projects located within the right-of-way of a roadway that is functionally classified as Federal-aid highway. This excludes roadways functionally classified as local roads or rural minor collectors, which are exempt. Contracting agencies may elect to apply these requirements to other projects.

The following provisions are from the U.S. Department of Labor regulations in 29 CFR 5.5 "Contract provisions and related matters" with minor revisions to conform to the FHWA-1273 format and FHWA program requirements.

1. Minimum wages

a. All laborers and mechanics employed or working upon the site of the work, will be paid unconditionally and not less often than once a week, and without subsequent deduction or rebate on any account (except such payroll deductions as are permitted by regulations issued by the Secretary of Labor under the Copeland Act (29 CFR part 3)), the full amount of wages and bona fide fringe benefits (or cash equivalents thereof) due at time of payment computed at rates not less than those contained in the wage determination of the Secretary of Labor which is attached hereto and made a part hereof, regardless of any contractual relationship which may be alleged to exist between the contractor and such laborers and mechanics.

Contributions made or costs reasonably anticipated for bona fide fringe benefits under section 1(b)(2) of the Davis-Bacon Act on behalf of laborers or mechanics are considered wages paid to such laborers or mechanics, subject to the provisions

of paragraph 1.d. of this section; also, regular contributions made or costs incurred for more than a weekly period (but not less often than quarterly) under plans, funds, or programs which cover the particular weekly period, are deemed to be constructively made or incurred during such weekly period. Such laborers and mechanics shall be paid the appropriate wage rate and fringe benefits on the wage determination for the classification of work actually performed, without regard to skill, except as provided in 29 CFR 5.5(a)(4). Laborers or mechanics performing work in more than one classification may be compensated at the rate specified for each classification for the time actually worked therein: Provided, That the employer's payroll records accurately set forth the time spent in each classification in which work is performed. The wage determination (including any additional classification and wage rates conformed under paragraph 1.b. of this section) and the Davis-Bacon poster (WH-1321) shall be posted at all times by the contractor and its subcontractors at the site of the work in a prominent and accessible place where it can be easily seen by the workers.

b.(1) The contracting officer shall require that any class of laborers or mechanics, including helpers, which is not listed in the wage determination and which is to be employed under the contract shall be classified in conformance with the wage determination. The contracting officer shall approve an additional classification and wage rate and fringe benefits therefore only when the following criteria have been met:

(i) The work to be performed by the classification requested is not performed by a classification in the wage determination; and

(ii) The classification is utilized in the area by the construction industry; and

(iii) The proposed wage rate, including any bona fide fringe benefits, bears a reasonable relationship to the wage rates contained in the wage determination.

(2) If the contractor and the laborers and mechanics to be employed in the classification (if known), or their representatives, and the contracting officer agree on the classification and wage rate (including the amount designated for fringe benefits where appropriate), a report of the action taken shall be sent by the contracting officer to the Administrator of the Wage and Hour Division, Employment Standards Administration, U.S. Department of Labor, Washington, DC 20210. The Administrator, or an authorized representative, will approve, modify, or disapprove every additional classification action within 30 days of receipt and so advise the contracting officer or will notify the contracting officer within the 30-day period that additional time is necessary.

(3) In the event the contractor, the laborers or mechanics to be employed in the classification or their representatives, and the contracting officer do not agree on the proposed classification and wage rate (including the amount designated for fringe benefits, where appropriate), the contracting officer shall refer the questions, including the views of all interested parties and the recommendation of the contracting officer, to the Wage and Hour Administrator for determination. The Wage and Hour Administrator, or an authorized representative, will issue a determination within 30 days of receipt and so advise the contracting officer or

will notify the contracting officer within the 30-day period that additional time is necessary.

(4) The wage rate (including fringe benefits where appropriate) determined pursuant to paragraphs 1.b.(2) or 1.b.(3) of this section, shall be paid to all workers performing work in the classification under this contract from the first day on which work is performed in the classification.

c. Whenever the minimum wage rate prescribed in the contract for a class of laborers or mechanics includes a fringe benefit which is not expressed as an hourly rate, the contractor shall either pay the benefit as stated in the wage determination or shall pay another bona fide fringe benefit or an hourly cash equivalent thereof.

d. If the contractor does not make payments to a trustee or other third person, the contractor may consider as part of the wages of any laborer or mechanic the amount of any costs reasonably anticipated in providing bona fide fringe benefits under a plan or program, Provided, That the Secretary of Labor has found, upon the written request of the contractor, that the applicable standards of the Davis-Bacon Act have been met. The Secretary of Labor may require the contractor to set aside in a separate account assets for the meeting of obligations under the plan or program.

2. Withholding

The contracting agency shall upon its own action or upon written request of an authorized representative of the Department of Labor, withhold or cause to be withheld from the contractor under this contract, or any other Federal contract with the same prime contractor, or any other federally-assisted contract subject to Davis-Bacon prevailing wage requirements, which is held by the same prime contractor, so much of the accrued payments or advances as may be considered necessary to pay laborers and mechanics, including apprentices, trainees, and helpers, employed by the contractor or any subcontractor the full amount of wages required by the contract. In the event of failure to pay any laborer or mechanic, including any apprentice, trainee, or helper, employed or working on the site of the work, all or part of the wages required by the contract, the contracting agency may, after written notice to the contractor, take such action as may be necessary to cause the suspension of any further payment, advance, or guarantee of funds until such violations have ceased.

3. Payrolls and basic records

a. Payrolls and basic records relating thereto shall be maintained by the contractor during the course of the work and preserved for a period of three years thereafter for all laborers and mechanics working at the site of the work. Such records shall contain the name, address, and social security number of each such worker, his or her correct classification, hourly rates of wages paid (including rates of contributions or costs anticipated for bona fide fringe benefits or cash equivalents thereof of the types described in section 1(b)(2)(B) of the Davis-Bacon Act), daily and weekly number of hours worked, deductions made and actual wages paid. Whenever the Secretary of Labor has found under 29 CFR 5.5(a)(1)(iv) that the wages of any laborer or mechanic include the amount of any costs reasonably anticipated in providing benefits under a plan or program described in section 1(b)(2)(B) of the Davis-

Bacon Act, the contractor shall maintain records which show that the commitment to provide such benefits is enforceable, that the plan or program is financially responsible, and that the plan or program has been communicated in writing to the laborers or mechanics affected, and records which show the costs anticipated or the actual cost incurred in providing such benefits. Contractors employing apprentices or trainees under approved programs shall maintain written evidence of the registration of apprenticeship programs and certification of trainee programs, the registration of the apprentices and trainees, and the ratios and wage rates prescribed in the applicable programs.

b.(1) The contractor shall submit weekly for each week in which any contract work is performed a copy of all payrolls to the contracting agency. The payrolls submitted shall set out accurately and completely all of the information required to be maintained under 29 CFR 5.5(a)(3)(i), except that full social security numbers and home addresses shall not be included on weekly transmittals. Instead the payrolls shall only need to include an individually identifying number for each employee (e.g. , the last four digits of the employee's social security number). The required weekly payroll information may be submitted in any form desired. Optional Form WH-347 is available for this purpose from the Wage and Hour Division Web site at <http://www.dol.gov/esa/whd/forms/wh347instr.htm> or its successor site. The prime contractor is responsible for the submission of copies of payrolls by all subcontractors. Contractors and subcontractors shall maintain the full social security number and current address of each covered worker, and shall provide them upon request to the contracting agency for transmission to the State DOT, the FHWA or the Wage and Hour Division of the Department of Labor for purposes of an investigation or audit of compliance with prevailing wage requirements. It is not a violation of this section for a prime contractor to require a subcontractor to provide addresses and social security numbers to the prime contractor for its own records, without weekly submission to the contracting agency..

(2) Each payroll submitted shall be accompanied by a "Statement of Compliance," signed by the contractor or subcontractor or his or her agent who pays or supervises the payment of the persons employed under the contract and shall certify the following:

(i) That the payroll for the payroll period contains the information required to be provided under §5.5 (a)(3)(ii) of Regulations, 29 CFR part 5, the appropriate information is being maintained under §5.5 (a)(3)(i) of Regulations, 29 CFR part 5, and that such information is correct and complete;

(ii) That each laborer or mechanic (including each helper, apprentice, and trainee) employed on the contract during the payroll period has been paid the full weekly wages earned, without rebate, either directly or indirectly, and that no deductions have been made either directly or indirectly from the full wages earned, other than permissible deductions as set forth in Regulations, 29 CFR part 3;

(iii) That each laborer or mechanic has been paid not less than the applicable wage rates and fringe benefits or cash equivalents for the classification of work performed, as specified in the applicable wage determination incorporated into the contract.

(3) The weekly submission of a properly executed certification set forth on the reverse side of Optional Form WH-347 shall satisfy the requirement for submission of the "Statement of Compliance" required by paragraph 3.b.(2) of this section.

(4) The falsification of any of the above certifications may subject the contractor or subcontractor to civil or criminal prosecution under section 1001 of title 18 and section 231 of title 31 of the United States Code.

c. The contractor or subcontractor shall make the records required under paragraph 3.a. of this section available for inspection, copying, or transcription by authorized representatives of the contracting agency, the State DOT, the FHWA, or the Department of Labor, and shall permit such representatives to interview employees during working hours on the job. If the contractor or subcontractor fails to submit the required records or to make them available, the FHWA may, after written notice to the contractor, the contracting agency or the State DOT, take such action as may be necessary to cause the suspension of any further payment, advance, or guarantee of funds. Furthermore, failure to submit the required records upon request or to make such records available may be grounds for debarment action pursuant to 29 CFR 5.12.

4. Apprentices and trainees

a. Apprentices (programs of the USDOL).

Apprentices will be permitted to work at less than the predetermined rate for the work they performed when they are employed pursuant to and individually registered in a bona fide apprenticeship program registered with the U.S. Department of Labor, Employment and Training Administration, Office of Apprenticeship Training, Employer and Labor Services, or with a State Apprenticeship Agency recognized by the Office, or if a person is employed in his or her first 90 days of probationary employment as an apprentice in such an apprenticeship program, who is not individually registered in the program, but who has been certified by the Office of Apprenticeship Training, Employer and Labor Services or a State Apprenticeship Agency (where appropriate) to be eligible for probationary employment as an apprentice.

The allowable ratio of apprentices to journeymen on the job site in any craft classification shall not be greater than the ratio permitted to the contractor as to the entire work force under the registered program. Any worker listed on a payroll at an apprentice wage rate, who is not registered or otherwise employed as stated above, shall be paid not less than the applicable wage rate on the wage determination for the classification of work actually performed. In addition, any apprentice performing work on the job site in excess of the ratio permitted under the registered program shall be paid not less than the applicable wage rate on the wage determination for the work actually performed. Where a contractor is performing construction on a project in a locality other than that in which its program is registered, the ratios and wage rates (expressed in percentages of the journeyman's hourly rate) specified in the contractor's or subcontractor's registered program shall be observed.

Every apprentice must be paid at not less than the rate specified in the registered program for the apprentice's level of progress, expressed as a percentage of the journeymen hourly

rate specified in the applicable wage determination. Apprentices shall be paid fringe benefits in accordance with the provisions of the apprenticeship program. If the apprenticeship program does not specify fringe benefits, apprentices must be paid the full amount of fringe benefits listed on the wage determination for the applicable classification. If the Administrator determines that a different practice prevails for the applicable apprentice classification, fringes shall be paid in accordance with that determination.

In the event the Office of Apprenticeship Training, Employer and Labor Services, or a State Apprenticeship Agency recognized by the Office, withdraws approval of an apprenticeship program, the contractor will no longer be permitted to utilize apprentices at less than the applicable predetermined rate for the work performed until an acceptable program is approved.

b. Trainees (programs of the USDOL).

Except as provided in 29 CFR 5.16, trainees will not be permitted to work at less than the predetermined rate for the work performed unless they are employed pursuant to and individually registered in a program which has received prior approval, evidenced by formal certification by the U.S. Department of Labor, Employment and Training Administration.

The ratio of trainees to journeymen on the job site shall not be greater than permitted under the plan approved by the Employment and Training Administration.

Every trainee must be paid at not less than the rate specified in the approved program for the trainee's level of progress, expressed as a percentage of the journeyman hourly rate specified in the applicable wage determination. Trainees shall be paid fringe benefits in accordance with the provisions of the trainee program. If the trainee program does not mention fringe benefits, trainees shall be paid the full amount of fringe benefits listed on the wage determination unless the Administrator of the Wage and Hour Division determines that there is an apprenticeship program associated with the corresponding journeyman wage rate on the wage determination which provides for less than full fringe benefits for apprentices. Any employee listed on the payroll at a trainee rate who is not registered and participating in a training plan approved by the Employment and Training Administration shall be paid not less than the applicable wage rate on the wage determination for the classification of work actually performed. In addition, any trainee performing work on the job site in excess of the ratio permitted under the registered program shall be paid not less than the applicable wage rate on the wage determination for the work actually performed.

In the event the Employment and Training Administration withdraws approval of a training program, the contractor will no longer be permitted to utilize trainees at less than the applicable predetermined rate for the work performed until an acceptable program is approved.

c. Equal employment opportunity. The utilization of apprentices, trainees and journeymen under this part shall be in conformity with the equal employment opportunity requirements of Executive Order 11246, as amended, and 29 CFR part 30.

d. Apprentices and Trainees (programs of the U.S. DOT).

Apprentices and trainees working under apprenticeship and skill training programs which have been certified by the Secretary of Transportation as promoting EEO in connection with Federal-aid highway construction programs are not subject to the requirements of paragraph 4 of this Section IV. The straight time hourly wage rates for apprentices and trainees under such programs will be established by the particular programs. The ratio of apprentices and trainees to journeymen shall not be greater than permitted by the terms of the particular program.

5. Compliance with Copeland Act requirements. The contractor shall comply with the requirements of 29 CFR part 3, which are incorporated by reference in this contract.

6. Subcontracts. The contractor or subcontractor shall insert Form FHWA-1273 in any subcontracts and also require the subcontractors to include Form FHWA-1273 in any lower tier subcontracts. The prime contractor shall be responsible for the compliance by any subcontractor or lower tier subcontractor with all the contract clauses in 29 CFR 5.5.

7. Contract termination: debarment. A breach of the contract clauses in 29 CFR 5.5 may be grounds for termination of the contract, and for debarment as a contractor and a subcontractor as provided in 29 CFR 5.12.

8. Compliance with Davis-Bacon and Related Act requirements. All rulings and interpretations of the Davis-Bacon and Related Acts contained in 29 CFR parts 1, 3, and 5 are herein incorporated by reference in this contract.

9. Disputes concerning labor standards. Disputes arising out of the labor standards provisions of this contract shall not be subject to the general disputes clause of this contract. Such disputes shall be resolved in accordance with the procedures of the Department of Labor set forth in 29 CFR parts 5, 6, and 7. Disputes within the meaning of this clause include disputes between the contractor (or any of its subcontractors) and the contracting agency, the U.S. Department of Labor, or the employees or their representatives.

10. Certification of eligibility.

a. By entering into this contract, the contractor certifies that neither it (nor he or she) nor any person or firm who has an interest in the contractor's firm is a person or firm ineligible to be awarded Government contracts by virtue of section 3(a) of the Davis-Bacon Act or 29 CFR 5.12(a)(1).

b. No part of this contract shall be subcontracted to any person or firm ineligible for award of a Government contract by virtue of section 3(a) of the Davis-Bacon Act or 29 CFR 5.12(a)(1).

c. The penalty for making false statements is prescribed in the U.S. Criminal Code, 18 U.S.C. 1001.

V. CONTRACT WORK HOURS AND SAFETY STANDARDS ACT

The following clauses apply to any Federal-aid construction contract in an amount in excess of \$100,000 and subject to the overtime provisions of the Contract Work Hours and Safety Standards Act. These clauses shall be inserted in addition to the clauses required by 29 CFR 5.5(a) or 29 CFR 4.6. As used in this paragraph, the terms laborers and mechanics include watchmen and guards.

1. Overtime requirements. No contractor or subcontractor contracting for any part of the contract work which may require or involve the employment of laborers or mechanics shall require or permit any such laborer or mechanic in any workweek in which he or she is employed on such work to work in excess of forty hours in such workweek unless such laborer or mechanic receives compensation at a rate not less than one and one-half times the basic rate of pay for all hours worked in excess of forty hours in such workweek.

2. Violation; liability for unpaid wages; liquidated damages. In the event of any violation of the clause set forth in paragraph (1.) of this section, the contractor and any subcontractor responsible therefor shall be liable for the unpaid wages. In addition, such contractor and subcontractor shall be liable to the United States (in the case of work done under contract for the District of Columbia or a territory, to such District or to such territory), for liquidated damages. Such liquidated damages shall be computed with respect to each individual laborer or mechanic, including watchmen and guards, employed in violation of the clause set forth in paragraph (1.) of this section, in the sum of \$10 for each calendar day on which such individual was required or permitted to work in excess of the standard workweek of forty hours without payment of the overtime wages required by the clause set forth in paragraph (1.) of this section.

3. Withholding for unpaid wages and liquidated damages. The FHWA or the contracting agency shall upon its own action or upon written request of an authorized representative of the Department of Labor withhold or cause to be withheld, from any moneys payable on account of work performed by the contractor or subcontractor under any such contract or any other Federal contract with the same prime contractor, or any other federally-assisted contract subject to the Contract Work Hours and Safety Standards Act, which is held by the same prime contractor, such sums as may be determined to be necessary to satisfy any liabilities of such contractor or subcontractor for unpaid wages and liquidated damages as provided in the clause set forth in paragraph (2.) of this section.

4. Subcontracts. The contractor or subcontractor shall insert in any subcontracts the clauses set forth in paragraph (1.) through (4.) of this section and also a clause requiring the subcontractors to include these clauses in any lower tier subcontracts. The prime contractor shall be responsible for compliance by any subcontractor or lower tier subcontractor with the clauses set forth in paragraphs (1.) through (4.) of this section.

VI. SUBLETTING OR ASSIGNING THE CONTRACT

This provision is applicable to all Federal-aid construction contracts on the National Highway System.

1. The contractor shall perform with its own organization contract work amounting to not less than 30 percent (or a greater percentage if specified elsewhere in the contract) of the total original contract price, excluding any specialty items designated by the contracting agency. Specialty items may be performed by subcontract and the amount of any such specialty items performed may be deducted from the total original contract price before computing the amount of work required to be performed by the contractor's own organization (23 CFR 635.116).

a. The term "perform work with its own organization" refers to workers employed or leased by the prime contractor, and equipment owned or rented by the prime contractor, with or without operators. Such term does not include employees or equipment of a subcontractor or lower tier subcontractor, agents of the prime contractor, or any other assignees. The term may include payments for the costs of hiring leased employees from an employee leasing firm meeting all relevant Federal and State regulatory requirements. Leased employees may only be included in this term if the prime contractor meets all of the following conditions:

(1) the prime contractor maintains control over the supervision of the day-to-day activities of the leased employees;

(2) the prime contractor remains responsible for the quality of the work of the leased employees;

(3) the prime contractor retains all power to accept or exclude individual employees from work on the project; and

(4) the prime contractor remains ultimately responsible for the payment of predetermined minimum wages, the submission of payrolls, statements of compliance and all other Federal regulatory requirements.

b. "Specialty Items" shall be construed to be limited to work that requires highly specialized knowledge, abilities, or equipment not ordinarily available in the type of contracting organizations qualified and expected to bid or propose on the contract as a whole and in general are to be limited to minor components of the overall contract.

2. The contract amount upon which the requirements set forth in paragraph (1) of Section VI is computed includes the cost of material and manufactured products which are to be purchased or produced by the contractor under the contract provisions.

3. The contractor shall furnish (a) a competent superintendent or supervisor who is employed by the firm, has full authority to direct performance of the work in accordance with the contract requirements, and is in charge of all construction operations (regardless of who performs the work) and (b) such other of its own organizational resources (supervision, management, and engineering services) as the contracting officer determines is necessary to assure the performance of the contract.

4. No portion of the contract shall be sublet, assigned or otherwise disposed of except with the written consent of the contracting officer, or authorized representative, and such consent when given shall not be construed to relieve the contractor of any responsibility for the fulfillment of the contract. Written consent will be given only after the contracting agency has assured that each subcontract is

evidenced in writing and that it contains all pertinent provisions and requirements of the prime contract.

5. The 30% self-performance requirement of paragraph (1) is not applicable to design-build contracts; however, contracting agencies may establish their own self-performance requirements.

VII. SAFETY: ACCIDENT PREVENTION

This provision is applicable to all Federal-aid construction contracts and to all related subcontracts.

1. In the performance of this contract the contractor shall comply with all applicable Federal, State, and local laws governing safety, health, and sanitation (23 CFR 635). The contractor shall provide all safeguards, safety devices and protective equipment and take any other needed actions as it determines, or as the contracting officer may determine, to be reasonably necessary to protect the life and health of employees on the job and the safety of the public and to protect property in connection with the performance of the work covered by the contract.

2. It is a condition of this contract, and shall be made a condition of each subcontract, which the contractor enters into pursuant to this contract, that the contractor and any subcontractor shall not permit any employee, in performance of the contract, to work in surroundings or under conditions which are unsanitary, hazardous or dangerous to his/her health or safety, as determined under construction safety and health standards (29 CFR 1926) promulgated by the Secretary of Labor, in accordance with Section 107 of the Contract Work Hours and Safety Standards Act (40 U.S.C. 3704).

3. Pursuant to 29 CFR 1926.3, it is a condition of this contract that the Secretary of Labor or authorized representative thereof, shall have right of entry to any site of contract performance to inspect or investigate the matter of compliance with the construction safety and health standards and to carry out the duties of the Secretary under Section 107 of the Contract Work Hours and Safety Standards Act (40 U.S.C.3704).

VIII. FALSE STATEMENTS CONCERNING HIGHWAY PROJECTS

This provision is applicable to all Federal-aid construction contracts and to all related subcontracts.

In order to assure high quality and durable construction in conformity with approved plans and specifications and a high degree of reliability on statements and representations made by engineers, contractors, suppliers, and workers on Federal-aid highway projects, it is essential that all persons concerned with the project perform their functions as carefully, thoroughly, and honestly as possible. Willful falsification, distortion, or misrepresentation with respect to any facts related to the project is a violation of Federal law. To prevent any misunderstanding regarding the seriousness of these and similar acts, Form FHWA-1022 shall be posted on each Federal-aid highway project (23 CFR 635) in one or more places where it is readily available to all persons concerned with the project:

18 U.S.C. 1020 reads as follows:

"Whoever, being an officer, agent, or employee of the United States, or of any State or Territory, or whoever, whether a person, association, firm, or corporation, knowingly makes any false statement, false representation, or false report as to the character, quality, quantity, or cost of the material used or to be used, or the quantity or quality of the work performed or to be performed, or the cost thereof in connection with the submission of plans, maps, specifications, contracts, or costs of construction on any highway or related project submitted for approval to the Secretary of Transportation; or

Whoever knowingly makes any false statement, false representation, false report or false claim with respect to the character, quality, quantity, or cost of any work performed or to be performed, or materials furnished or to be furnished, in connection with the construction of any highway or related project approved by the Secretary of Transportation; or

Whoever knowingly makes any false statement or false representation as to material fact in any statement, certificate, or report submitted pursuant to provisions of the Federal-aid Roads Act approved July 1, 1916, (39 Stat. 355), as amended and supplemented;

Shall be fined under this title or imprisoned not more than 5 years or both."

IX. IMPLEMENTATION OF CLEAN AIR ACT AND FEDERAL WATER POLLUTION CONTROL ACT

This provision is applicable to all Federal-aid construction contracts and to all related subcontracts.

By submission of this bid/proposal or the execution of this contract, or subcontract, as appropriate, the bidder, proposer, Federal-aid construction contractor, or subcontractor, as appropriate, will be deemed to have stipulated as follows:

1. That any person who is or will be utilized in the performance of this contract is not prohibited from receiving an award due to a violation of Section 508 of the Clean Water Act or Section 306 of the Clean Air Act.
2. That the contractor agrees to include or cause to be included the requirements of paragraph (1) of this Section X in every subcontract, and further agrees to take such action as the contracting agency may direct as a means of enforcing such requirements.

X. CERTIFICATION REGARDING DEBARMENT, SUSPENSION, INELIGIBILITY AND VOLUNTARY EXCLUSION

This provision is applicable to all Federal-aid construction contracts, design-build contracts, subcontracts, lower-tier subcontracts, purchase orders, lease agreements, consultant contracts or any other covered transaction requiring FHWA approval or that is estimated to cost \$25,000 or more – as defined in 2 CFR Parts 180 and 1200.

1. Instructions for Certification – First Tier Participants:

- a. By signing and submitting this proposal, the prospective first tier participant is providing the certification set out below.
- b. The inability of a person to provide the certification set out below will not necessarily result in denial of participation in this

covered transaction. The prospective first tier participant shall submit an explanation of why it cannot provide the certification set out below. The certification or explanation will be considered in connection with the department or agency's determination whether to enter into this transaction. However, failure of the prospective first tier participant to furnish a certification or an explanation shall disqualify such a person from participation in this transaction.

c. The certification in this clause is a material representation of fact upon which reliance was placed when the contracting agency determined to enter into this transaction. If it is later determined that the prospective participant knowingly rendered an erroneous certification, in addition to other remedies available to the Federal Government, the contracting agency may terminate this transaction for cause of default.

d. The prospective first tier participant shall provide immediate written notice to the contracting agency to whom this proposal is submitted if any time the prospective first tier participant learns that its certification was erroneous when submitted or has become erroneous by reason of changed circumstances.

e. The terms "covered transaction," "debarred," "suspended," "ineligible," "participant," "person," "principal," and "voluntarily excluded," as used in this clause, are defined in 2 CFR Parts 180 and 1200. "First Tier Covered Transactions" refers to any covered transaction between a grantee or subgrantee of Federal funds and a participant (such as the prime or general contract). "Lower Tier Covered Transactions" refers to any covered transaction under a First Tier Covered Transaction (such as subcontracts). "First Tier Participant" refers to the participant who has entered into a covered transaction with a grantee or subgrantee of Federal funds (such as the prime or general contractor). "Lower Tier Participant" refers any participant who has entered into a covered transaction with a First Tier Participant or other Lower Tier Participants (such as subcontractors and suppliers).

f. The prospective first tier participant agrees by submitting this proposal that, should the proposed covered transaction be entered into, it shall not knowingly enter into any lower tier covered transaction with a person who is debarred, suspended, declared ineligible, or voluntarily excluded from participation in this covered transaction, unless authorized by the department or agency entering into this transaction.

g. The prospective first tier participant further agrees by submitting this proposal that it will include the clause titled "Certification Regarding Debarment, Suspension, Ineligibility and Voluntary Exclusion-Lower Tier Covered Transactions," provided by the department or contracting agency, entering into this covered transaction, without modification, in all lower tier covered transactions and in all solicitations for lower tier covered transactions exceeding the \$25,000 threshold.

h. A participant in a covered transaction may rely upon a certification of a prospective participant in a lower tier covered transaction that is not debarred, suspended, ineligible, or voluntarily excluded from the covered transaction, unless it knows that the certification is erroneous. A participant is responsible for ensuring that its principals are not suspended, debarred, or otherwise ineligible to participate in covered transactions. To verify the eligibility of its principals, as well as the eligibility of any lower tier prospective participants, each participant may, but is not required to, check the Excluded Parties List System website (<https://www.epls.gov/>), which is compiled by the General Services Administration.

i. Nothing contained in the foregoing shall be construed to require the establishment of a system of records in order to render in good faith the certification required by this clause. The knowledge and information of the prospective participant is not required to exceed that which is normally possessed by a prudent person in the ordinary course of business dealings.

j. Except for transactions authorized under paragraph (f) of these instructions, if a participant in a covered transaction knowingly enters into a lower tier covered transaction with a person who is suspended, debarred, ineligible, or voluntarily excluded from participation in this transaction, in addition to other remedies available to the Federal Government, the department or agency may terminate this transaction for cause or default.

2. Certification Regarding Debarment, Suspension, Ineligibility and Voluntary Exclusion – First Tier Participants:

a. The prospective first tier participant certifies to the best of its knowledge and belief, that it and its principals:

(1) Are not presently debarred, suspended, proposed for debarment, declared ineligible, or voluntarily excluded from participating in covered transactions by any Federal department or agency;

(2) Have not within a three-year period preceding this proposal been convicted of or had a civil judgment rendered against them for commission of fraud or a criminal offense in connection with obtaining, attempting to obtain, or performing a public (Federal, State or local) transaction or contract under a public transaction; violation of Federal or State antitrust statutes or commission of embezzlement, theft, forgery, bribery, falsification or destruction of records, making false statements, or receiving stolen property;

(3) Are not presently indicted for or otherwise criminally or civilly charged by a governmental entity (Federal, State or local) with commission of any of the offenses enumerated in paragraph (a)(2) of this certification; and

(4) Have not within a three-year period preceding this application/proposal had one or more public transactions (Federal, State or local) terminated for cause or default.

b. Where the prospective participant is unable to certify to any of the statements in this certification, such prospective participant shall attach an explanation to this proposal.

2. Instructions for Certification - Lower Tier Participants:

(Applicable to all subcontracts, purchase orders and other lower tier transactions requiring prior FHWA approval or estimated to cost \$25,000 or more - 2 CFR Parts 180 and 1200)

a. By signing and submitting this proposal, the prospective lower tier is providing the certification set out below.

b. The certification in this clause is a material representation of fact upon which reliance was placed when this transaction was entered into. If it is later determined that the prospective lower tier participant knowingly rendered an erroneous certification, in addition to other remedies available to the Federal Government, the department, or agency with which

this transaction originated may pursue available remedies, including suspension and/or debarment.

c. The prospective lower tier participant shall provide immediate written notice to the person to which this proposal is submitted if at any time the prospective lower tier participant learns that its certification was erroneous by reason of changed circumstances.

d. The terms "covered transaction," "debarred," "suspended," "ineligible," "participant," "person," "principal," and "voluntarily excluded," as used in this clause, are defined in 2 CFR Parts 180 and 1200. You may contact the person to which this proposal is submitted for assistance in obtaining a copy of those regulations. "First Tier Covered Transactions" refers to any covered transaction between a grantee or subgrantee of Federal funds and a participant (such as the prime or general contract). "Lower Tier Covered Transactions" refers to any covered transaction under a First Tier Covered Transaction (such as subcontracts). "First Tier Participant" refers to the participant who has entered into a covered transaction with a grantee or subgrantee of Federal funds (such as the prime or general contractor). "Lower Tier Participant" refers any participant who has entered into a covered transaction with a First Tier Participant or other Lower Tier Participants (such as subcontractors and suppliers).

e. The prospective lower tier participant agrees by submitting this proposal that, should the proposed covered transaction be entered into, it shall not knowingly enter into any lower tier covered transaction with a person who is debarred, suspended, declared ineligible, or voluntarily excluded from participation in this covered transaction, unless authorized by the department or agency with which this transaction originated.

f. The prospective lower tier participant further agrees by submitting this proposal that it will include this clause titled "Certification Regarding Debarment, Suspension, Ineligibility and Voluntary Exclusion-Lower Tier Covered Transaction," without modification, in all lower tier covered transactions and in all solicitations for lower tier covered transactions exceeding the \$25,000 threshold.

g. A participant in a covered transaction may rely upon a certification of a prospective participant in a lower tier covered transaction that is not debarred, suspended, ineligible, or voluntarily excluded from the covered transaction, unless it knows that the certification is erroneous. A participant is responsible for ensuring that its principals are not suspended, debarred, or otherwise ineligible to participate in covered transactions. To verify the eligibility of its principals, as well as the eligibility of any lower tier prospective participants, each participant may, but is not required to, check the Excluded Parties List System website (<https://www.epls.gov/>), which is compiled by the General Services Administration.

h. Nothing contained in the foregoing shall be construed to require establishment of a system of records in order to render in good faith the certification required by this clause. The knowledge and information of participant is not required to exceed that which is normally possessed by a prudent person in the ordinary course of business dealings.

i. Except for transactions authorized under paragraph e of these instructions, if a participant in a covered transaction knowingly enters into a lower tier covered transaction with a person who is suspended, debarred, ineligible, or voluntarily excluded from participation in this transaction, in addition to other remedies available to the Federal Government, the

department or agency with which this transaction originated may pursue available remedies, including suspension and/or debarment.

Certification Regarding Debarment, Suspension, Ineligibility and Voluntary Exclusion--Lower Tier Participants:

1. The prospective lower tier participant certifies, by submission of this proposal, that neither it nor its principals is presently debarred, suspended, proposed for debarment, declared ineligible, or voluntarily excluded from participating in covered transactions by any Federal department or agency.

2. Where the prospective lower tier participant is unable to certify to any of the statements in this certification, such prospective participant shall attach an explanation to this proposal.

XI. CERTIFICATION REGARDING USE OF CONTRACT FUNDS FOR LOBBYING

This provision is applicable to all Federal-aid construction contracts and to all related subcontracts which exceed \$100,000 (49 CFR 20).

1. The prospective participant certifies, by signing and submitting this bid or proposal, to the best of his or her knowledge and belief, that:

a. No Federal appropriated funds have been paid or will be paid, by or on behalf of the undersigned, to any person for influencing or attempting to influence an officer or employee of any Federal agency, a Member of Congress, an officer or employee of Congress, or an employee of a Member of Congress in connection with the awarding of any Federal contract, the making of any Federal grant, the making of any Federal loan, the entering into of any cooperative agreement, and the extension, continuation, renewal, amendment, or modification of any Federal contract, grant, loan, or cooperative agreement.

b. If any funds other than Federal appropriated funds have been paid or will be paid to any person for influencing or attempting to influence an officer or employee of any Federal agency, a Member of Congress, an officer or employee of Congress, or an employee of a Member of Congress in connection with this Federal contract, grant, loan, or cooperative agreement, the undersigned shall complete and submit Standard Form-LLL, "Disclosure Form to Report Lobbying," in accordance with its instructions.

2. This certification is a material representation of fact upon which reliance was placed when this transaction was made or entered into. Submission of this certification is a prerequisite for making or entering into this transaction imposed by 31 U.S.C. 1352. Any person who fails to file the required certification shall be subject to a civil penalty of not less than \$10,000 and not more than \$100,000 for each such failure.

3. The prospective participant also agrees by submitting its bid or proposal that the participant shall require that the language of this certification be included in all lower tier subcontracts, which exceed \$100,000 and that all such recipients shall certify and disclose accordingly.

**ATTACHMENT A - EMPLOYMENT AND MATERIALS
PREFERENCE FOR APPALACHIAN DEVELOPMENT
HIGHWAY SYSTEM OR APPALACHIAN LOCAL ACCESS
ROAD CONTRACTS**

This provision is applicable to all Federal-aid projects funded under the Appalachian Regional Development Act of 1965.

1. During the performance of this contract, the contractor undertaking to do work which is, or reasonably may be, done as on-site work, shall give preference to qualified persons who regularly reside in the labor area as designated by the DOL wherein the contract work is situated, or the subregion, or the Appalachian counties of the State wherein the contract work is situated, except:
 - a. To the extent that qualified persons regularly residing in the area are not available.
 - b. For the reasonable needs of the contractor to employ supervisory or specially experienced personnel necessary to assure an efficient execution of the contract work.
 - c. For the obligation of the contractor to offer employment to present or former employees as the result of a lawful collective bargaining contract, provided that the number of nonresident persons employed under this subparagraph (1c) shall not exceed 20 percent of the total number of employees employed by the contractor on the contract work, except as provided in subparagraph (4) below.
2. The contractor shall place a job order with the State Employment Service indicating (a) the classifications of the laborers, mechanics and other employees required to perform the contract work, (b) the number of employees required in each classification, (c) the date on which the participant estimates such employees will be required, and (d) any other pertinent information required by the State Employment Service to complete the job order form. The job order may be placed with the State Employment Service in writing or by telephone. If during the course of the contract work, the information submitted by the contractor in the original job order is substantially modified, the participant shall promptly notify the State Employment Service.
3. The contractor shall give full consideration to all qualified job applicants referred to him by the State Employment Service. The contractor is not required to grant employment to any job applicants who, in his opinion, are not qualified to perform the classification of work required.
4. If, within one week following the placing of a job order by the contractor with the State Employment Service, the State Employment Service is unable to refer any qualified job applicants to the contractor, or less than the number requested, the State Employment Service will forward a certificate to the contractor indicating the unavailability of applicants. Such certificate shall be made a part of the contractor's permanent project records. Upon receipt of this certificate, the contractor may employ persons who do not normally reside in the labor area to fill positions covered by the certificate, notwithstanding the provisions of subparagraph (1c) above.
5. The provisions of 23 CFR 633.207(e) allow the contracting agency to provide a contractual preference for the use of mineral resource materials native to the Appalachian region.
6. The contractor shall include the provisions of Sections 1 through 4 of this Attachment A in every subcontract for work which is, or reasonably may be, done as on-site work.

Code of Federal Regulations

Title 23 - Highways

Volume: 1

Date: 2013-04-01

Original Date: 2013-04-01

Title: Section 635.109 - Standardized changed condition clauses.

Context: Title 23 - Highways. CHAPTER I - FEDERAL HIGHWAY ADMINISTRATION, DEPARTMENT OF TRANSPORTATION. SUBCHAPTER G - ENGINEERING AND TRAFFIC OPERATIONS. PART 635 - CONSTRUCTION AND MAINTENANCE. Subpart A - Contract Procedures.

§ 635.109 Standardized changed condition clauses.

(a) Except as provided in paragraph (b) of this section, the following changed conditions contract clauses shall be made part of, and incorporated in, each highway construction project approved under 23 U.S.C. 106:

(1) *Differing site conditions.* (i) During the progress of the work, if subsurface or latent physical conditions are encountered at the site differing materially from those indicated in the contract or if unknown physical conditions of an unusual nature, differing materially from those ordinarily encountered and generally recognized as inherent in the work provided for in the contract, are encountered at the site, the party discovering such conditions shall promptly notify the other party in writing of the specific differing conditions before the site is disturbed and before the affected work is performed.

(ii) Upon written notification, the engineer will investigate the conditions, and if it is determined that the conditions materially differ and cause an increase or decrease in the cost or time required for the performance of any work under the contract, an adjustment, excluding anticipated profits, will be made and the contract modified in writing accordingly. The engineer will notify the contractor of the determination whether or not an adjustment of the contract is warranted.

(iii) No contract adjustment which results in a benefit to the contractor will be allowed unless the contractor has provided the required written notice.

(iv) No contract adjustment will be allowed under this clause for any effects caused on unchanged work. (This provision may be omitted by the STD's at their option.)

(2) *Suspensions of work ordered by the engineer.* (i) If the performance of all or any portion of the work is suspended or delayed by the engineer in writing for an unreasonable period of time (not originally anticipated, customary, or inherent to the construction industry) and the contractor believes that additional compensation and/or contract time is due as a result of such suspension or delay, the contractor shall submit to the engineer in writing a request for adjustment within 7 calendar days of receipt of the notice to resume work. The request shall set forth the reasons and support for such adjustment.

(ii) Upon receipt, the engineer will evaluate the contractor's request. If the engineer agrees that the cost and/or time required for the performance of the contract has increased as a result of such suspension and the suspension was caused by conditions beyond the control of and not the fault of the contractor, its suppliers, or subcontractors at any approved tier, and not caused by weather, the engineer will make an adjustment (excluding profit) and modify the contract in writing accordingly. The contractor will be notified of the engineer's determination whether or not an adjustment of the contract is warranted.

(iii) No contract adjustment will be allowed unless the contractor has submitted the request for adjustment within the time prescribed.

(iv) No contract adjustment will be allowed under this clause to the extent that performance would have been suspended or delayed by any other cause, or for which an adjustment is provided or

excluded under any other term or condition of this contract.

(3) *Significant changes in the character of work.* (i) The engineer reserves the right to make, in writing, at any time during the work, such changes in quantities and such alterations in the work as are necessary to satisfactorily complete the project. Such changes in quantities and alterations shall not invalidate the contract nor release the surety, and the contractor agrees to perform the work as altered.

(ii) If the alterations or changes in quantities significantly change the character of the work under the contract, whether such alterations or changes are in themselves significant changes to the character of the work or by affecting other work cause such other work to become significantly different in character, an adjustment, excluding anticipated profit, will be made to the contract. The basis for the adjustment shall be agreed upon prior to the performance of the work. If a basis cannot be agreed upon, then an adjustment will be made either for or against the contractor in such amount as the engineer may determine to be fair and equitable.

(iii) If the alterations or changes in quantities do not significantly change the character of the work to be performed under the contract, the altered work will be paid for as provided elsewhere in the contract.

(iv) The term "significant change" shall be construed to apply only to the following circumstances:

(A) When the character of the work as altered differs materially in kind or nature from that involved or included in the original proposed construction; or

(B) When a major item of work, as defined elsewhere in the contract, is increased in excess of 125 percent or decreased below 75 percent of the original contract quantity. Any allowance for an increase in quantity shall apply only to that portion in excess of 125 percent of original contract item quantity, or in case of a decrease below 75 percent, to the actual amount of work performed.

(b) The provisions of this section shall be governed by the following:

(1) Where State statute does not permit one or more of the contract clauses included in paragraph (a) of this section, the State statute shall prevail and such clause or clauses need not be made applicable to Federal-aid highway contracts.

(2) Where the State transportation department has developed and implemented one or more of the contract clauses included in paragraph (a) of this section, such clause or clauses, as developed by the State transportation department may be included in Federal-aid highway contracts in lieu of the corresponding clause or clauses in paragraph (a) of this section. The State's action must be pursuant to a specific State statute requiring differing contract conditions clauses. Such State developed clause or clauses, however, must be in conformance with 23 U.S.C., 23 CFR and other applicable Federal statutes and regulations as appropriate and shall be subject to the Division Administrator's approval as part of the PS&E.

(c) In the case of a design-build project, STDs are strongly encouraged to use "suspensions of work ordered by the engineer" clauses, and may consider "differing site condition" clauses and "significant changes in the character of work" clauses which are appropriate for the risk and responsibilities that are shared with the design-builder.

[56 FR 37004, Aug. 2, 1991; 57 FR 10062, Mar. 23, 1992, as amended at 67 FR 75925, Dec. 10, 2002]



Kentucky Transportation Cabinet
Office of Local Programs
LOCAL PUBLIC AGENCY CHANGE ORDER

TC 20-32
7/2010
Page 1 of 3

Page _____
Contract ID _____ PO2-628- _____ Project Sponsor _____
Change Order No _____ County _____
Contractor _____ Project Number _____
Contractor _____ Project Name _____
Address _____

Proposed Changes in Connection with Contract Items:

Item No.	Description	Quantity	Unit	Unit Price	Amount
<i>Total for this Page</i>					
<i>Total for Continuation Page(s)</i>					
<i>Total Contract Items</i>					

Proposed Items of Supplemental Agreement:

Ref. No.	Description	Quantity	Unit	Unit Price	Amount
<i>Total for this Page</i>					
<i>Total for Continuation Page(s)</i>					
<i>Total Supplemental Agreement</i>					
Total Amount					

Time Extension/Explanation:

Reasons for Proposed Changes and Cost Analysis:

If approved by Transportation Cabinet, the undersigned contractor agrees to do the work outlined herein and to accept as payment in full the basis of payment as set forth herein.

By: _____
Contractor

Date

Requested _____ DATE
Project Engineer
Recommended _____ DATE
District LPA Coordinator
Recommended _____ DATE
Commissioner of Rural & Municipal Aid
Approved _____ DATE
LPA Signature Authority

Title
Approved _____ DATE
Secretary of Transportation Cabinet